



Test Report No.: W7L-240430W002RF02



FCC TEST REPORT (PART 22)

Applicant:	Continental Automotive Systems, Inc.
Address:	21440 W Lake Cook Rd., Deer Park, IL 60010, USA

Manufacturer or Supplier:	Continental Automotive Systems, Inc.
Address:	21440 W Lake Cook Rd., Deer Park, IL 60010, USA
Product:	Module
Brand Name:	Continental
Model Name:	FE5NAR110, FE5NAR111
FCC ID:	LHJ-FE5NAR110
Date of tests:	May. 01, 2024 ~ Jun. 17, 2024

The tests have been carried out according to the requirements of the following standard:

- FCC PART 22, Subpart H FCC Part 2
- ANSI/TIA/EIA-603-D ANSI C63.26-2015
- ANSI/TIA/EIA-603-E

CONCLUSION: The submitted sample was found to COMPLY with the test requirement

Prepared by Simon Wang Engineer / Mobile Department	Approved by Luke Lu Manager / Mobile Department
Date: Jun. 17, 2024	Date: Jun. 17, 2024

This report is governed by, and incorporates by reference, the Conditions of Testing as posted at the date of issuance of this report at <http://www.bureauveritas.com/home/about-us/our-business/cps/about-us/terms-conditions/> and is intended for your exclusive use. Any copying or replication of this report to or for any other person or entity, or use of our name or trademark, is permitted only with our prior written permission. This report sets forth our findings solely with respect to the test samples identified herein. The results set forth in this report are not indicative or representative of the quality or characteristics of the lot from which a test sample was taken or any similar or identical product unless specifically and expressly noted. Our report includes all of the tests requested by you and the results thereof based upon the information that you provided to us. Measurement uncertainty is only provided upon request for accredited tests. Statements of conformity are based on simple acceptance criteria without taking measurement uncertainty into account, unless otherwise requested in writing. You have 60 days from date of issuance of this report to notify us of any material error or omission caused by our negligence or if you require measurement uncertainty; provided, however, that such notice shall be in writing and shall specifically address the issue you wish to raise. A failure to raise such issue within the prescribed time shall constitute your unqualified acceptance of the completeness of this report, the tests conducted and the correctness of the report contents.



TABLE OF CONTENTS

RELEASE CONTROL RECORD4

1 SUMMARY OF TEST RESULTS.....5

1.1 MEASUREMENT UNCERTAINTY6

1.2 TEST SITE AND INSTRUMENTS7

2 GENERAL INFORMATION8

2.1 GENERAL DESCRIPTION OF EUT8

2.2 CONFIGURATION OF SYSTEM UNDER TEST 11

2.3 DESCRIPTION OF SUPPORT UNITS 12

2.4 TEST ITEM AND TEST CONFIGURATION..... 12

2.5 EUT OPERATING CONDITIONS 16

2.6 GENERAL DESCRIPTION OF APPLIED STANDARDS 17

3 TEST TYPES AND RESULTS.....18

3.1 OUTPUT POWER MEASUREMENT 18

3.1.1 LIMITS OF OUTPUT POWER MEASUREMENT 18

3.1.2 TEST PROCEDURES 18

3.1.3 TEST SETUP 19

3.1.4 TEST RESULTS 20

3.2 FREQUENCY STABILITY MEASUREMENT 38

3.2.1 LIMITS OF FREQUENCY STABILITY MEASUREMENT 38

3.2.2 TEST PROCEDURE 38

3.2.3 TEST SETUP 38

3.2.4 TEST RESULTS 39

3.3 OCCUPIED BANDWIDTH MEASUREMENT 40

3.3.1 LIMITS OF OCCUPIED BANDWIDTH MEASUREMENT 40

3.3.2 TEST SETUP 40

3.3.3 TEST PROCEDURES 40

3.3.4 TEST RESULTS 41

3.4 BAND EDGE MEASUREMENT 42

3.4.1 LIMITS OF BAND EDGE MEASUREMENT 42

3.4.2 TEST SETUP 42

3.4.3 TEST PROCEDURES 43

3.4.4 TEST RESULTS 44

3.5 CONDUCTED SPURIOUS EMISSIONS..... 45

3.5.1 LIMITS OF CONDUCTED SPURIOUS EMISSIONS MEASUREMENT 45

3.5.2 TEST PROCEDURE 45

3.5.3 TEST SETUP 45

3.5.4 TEST RESULTS 46

3.6 RADIATED EMISSION MEASUREMENT 47

3.6.1 LIMITS OF RADIATED EMISSION MEASUREMENT 47

3.6.2 TEST PROCEDURES 47

3.6.3 DEVIATION FROM TEST STANDARD 47

3.6.4 TEST SETUP 48



**BUREAU
VERITAS**

Test Report No.: W7L-240430W002RF02

3.6.5	TEST RESULTS	50
3.7	PEAK TO AVERAGE RATIO	78
3.7.1	LIMITS OF PEAK TO AVERAGE RATIO MEASUREMENT	78
3.7.2	TEST SETUP	78
3.7.3	TEST PROCEDURES	78
3.7.4	TEST RESULTS	79
4	PHOTOGRAPHS OF THE TEST CONFIGURATION	80
5	INFORMATION ON THE TESTING LABORATORIES	81
6	MODIFICATIONS RECORDERS FOR ENGINEERING CHANGES TO THE EUT BY THE LAB	82



BUREAU
VERITAS

Test Report No.: W7L-240430W002RF02

RELEASE CONTROL RECORD

ISSUE NO.	REASON FOR CHANGE	DATE ISSUED
W7L-240430W002RF02	Original release	Jun. 17, 2024



1 SUMMARY OF TEST RESULTS

The EUT has been tested according to the following specifications:

APPLIED STANDARD: FCC Part 22 & Part 2		
STANDARD SECTION	TEST TYPE	RESULT
§2.1046	Conducted Output Power	Compliance
§22.913 (a)(5)	Effective Radiated Power	Compliance
§2.1055 §22.355	Frequency Stability	Compliance
§2.1049	Occupied Bandwidth	Compliance
§22.913 (d)	Peak to average ratio*	Compliance
§22.917(a)	Band Edge Measurements	Compliance
§2.1051 §22.917(a)	Conducted Spurious Emissions	Compliance
§2.1053 §22.917(a)	Radiated Spurious Emissions	Compliance

* Refer to KDB 971168 D01 Power Meas License Digital Systems v03r01.

NOTE:

1. The worst-case scenario for all measurements is based on an engineering evaluation made on different modulations. Then, QPSK and 16QAM were observed as the worst mode to LTE bands respectively and set for all conducted and radiated. Output power measurements were measured on QPSK, 16QAM, 64QAM modulations, and tests other than output power are performed only in worse-case QPSK and 16QAM modulations.
2. For Band Edge and Emission Mask: All BW combinations were tested. Combination pairs of the same BW are considered generally equivalent. The RB combinations were selected such that the signal is active closest to the band limit, as this is the worst case.
3. For Out of Band Emissions: All combination was tested. The highest power RB combination was selected as worst case.



1.1 MEASUREMENT UNCERTAINTY

Where relevant, the following measurement uncertainty levels have been estimated for tests performed on the EUT as specified in CISPR 16-4-2:

MEASUREMENT	UNCERTAINTY
Maximum Peak Output Power	±2.06dB
Frequency Stability	±76.97Hz
Radiated emissions (9KHz~30MHz)	±2.68dB
Radiated emissions (30MHz~1GHz)	±4.98dB
Radiated emissions (1GHz ~6GHz)	±4.70dB
Radiated emissions (6GHz ~18GHz)	±4.60dB
Radiated emissions (18GHz ~40GHz)	±4.12dB
Conducted emissions	±4.01dB
Occupied Channel Bandwidth	±43.58KHz
Band Edge Measurements	±4.70dB
Peak to average ratio	±0.76dB

This uncertainty represents an expanded uncertainty expressed at approximately the 95% confidence level using a coverage factor of k=2.



1.2 TEST SITE AND INSTRUMENTS

Equipment	Manufacturer	Model No.	Serial No.	Last Cal.	Next Cal.
MXE EMI Receiver	KEYSIGHT	N9038A-544	MY54450026	Mar. 28,24	Mar. 27,25
EXA Signal Analyzer	KEYSIGHT	N9010A-544	MY54510355	May.10,23	May.09,24
EXA Signal Analyzer	KEYSIGHT	N9010A-544	MY54510355	May.09,24	May.08,25
Loop Antenna	Schwarzbeck	FMZB 1519B	00173	Sep.03,23	Sep.02,24
Bilog Antenna	ETS-LINDGRE N	3143B	00161965	Feb. 18,24	Feb. 17,25
Horn Antenna	ETS-LINDGRE N	3117	00168692	Feb. 18,24	Feb. 17,25
Horn Antenna (18GHz-40GHz)	N/A	QWH-SL-18-40-K- SG/QMS-00361	15433	Sep.04, 23	Sep.03, 24
Radio Communication Analyzer	ANRITSU	MT8820C	6201465426	Feb. 14,24	Feb. 13,25
Signal Pre-Amplifier	EMSI	EMC 9135	980249	May. 06,23	May. 05,24
Signal Pre-Amplifier	EMSI	EMC 9135	980249	May. 05,24	May. 04,25
Signal Pre-Amplifier	EMSI	EMC 012645B	980257	May.10,23	May.09,24
Signal Pre-Amplifier	EMSI	EMC 012645B	980257	May.09,24	May.08,25
Signal Pre-Amplifier	EMSI	EMC 184045B	980259	Feb. 17,24	Feb.16,25
3m Semi-anechoic Chamber	ETS-LINDGRE N	9m*6m*6m	Euroshieldpn- CT0001143-121 6	Nov. 14,23	Nov. 13,26
Test Software	E3	V 9.160323	N/A	N/A	N/A
Test Software	JS1120	3.1.36	N/A	N/A	N/A
10dB Attenuator	JFW/USA	50HF-010-SMA	50HF-010-SMA	May. 06,23	May. 05,24
10dB Attenuator	JFW/USA	50HF-010-SMA	50HF-010-SMA	May. 05,24	May. 04,25
Power Meter	Anritsu	ML2495A	1506002	Feb. 14,24	Feb. 13,25
Power Sensor	Anritsu	MA2411B	1339352	Feb. 14,24	Feb. 13,25
Temperature Chamber	ESPEC	SH-242	93000855	May. 06,23	May. 05,24
Temperature Chamber	ESPEC	SH-242	93000855	May. 05,24	May. 04,25
MXG Analog Microwave Signal Generator	KEYSIGHT	N5183A	MY50143024	Feb. 14,24	Feb. 13,25
Base station R&S CMW500	Rohde&Schwa rz	CMW500	153085	May.10,23	May.09,24
Base station R&S CMW500	Rohde&Schwa rz	CMW500	153085	May.09,24	May.08,25
DC Source	Kikusui/JP	PMX18-5A	N/A	Aug. 11,23	Aug. 10,24

- NOTE:**
1. The calibration interval of the above test instruments is 12 months or 36 months, and the calibrations are traceable to CEPREI/CHINA, GRGT/CHINA and NIM/CHINA.
 2. The test was performed in 3m Semi-anechoic Chamber and RF Oven Room.
 3. The horn antenna is used only for the measurement of emission frequency above 1GHz if tested.
 4. The FCC Site Registration No. is 525120; The Designation No. is CN1171.



2 GENERAL INFORMATION

2.1 GENERAL DESCRIPTION OF EUT

PRODUCT	Module	
BRAND NAME	Continental	
MODEL NAME	FE5NAR110, FE5NAR111	
NOMINAL VOLTAGE	DC4.0V	
MODULATION TYPE	WCDMA	BPSK, QPSK
	LTE	QPSK, 16QAM, 64QAM
FREQUENCY RANGE	WCDMA	826.4MHz ~ 846.6MHz
	LTE Band 5 (Channel Bandwidth: 1.4MHz)	824.7MHz ~ 848.3MHz
	LTE Band 5 (Channel Bandwidth: 3MHz)	825.5MHz ~ 847.5MHz
	LTE Band 5 (Channel Bandwidth: 5MHz)	826.5MHz ~ 846.5MHz
	LTE Band 5 (Channel Bandwidth: 10MHz)	829MHz ~ 844MHz
	LTE Band 5B Channel Bandwidth: 3MHz+5MHz	825.6MHz ~ 846.5MHz
	LTE Band 5B Channel Bandwidth: 5MHz+3MHz	826.5MHz ~ 847.4MHz
	LTE Band 5B Channel Bandwidth: 5MHz+10MHz	826.8MHz ~ 844.0MHz
	LTE Band 5B Channel Bandwidth: 10MHz+5MHz	829.0MHz ~ 846.2MHz
	LTE Band 5B Channel Bandwidth: 10MHz+10MHz	829.0MHz ~ 844.0MHz
	MAX. ERP POWER	WCDMA
LTE Band 5 (Channel Bandwidth: 1.4MHz)		231.21mW
LTE Band 5 (Channel Bandwidth: 3MHz)		226.99mW
LTE Band 5 (Channel Bandwidth: 5MHz)		226.99mW
LTE Band 5 (Channel Bandwidth: 10MHz)		230.67mW



	LTE Band 5B Channel Bandwidth: 3MHz+5MHz	237.68mW
	LTE Band 5B Channel Bandwidth: 5MHz+3MHz	241.55mW
	LTE Band 5B Channel Bandwidth: 5MHz+10MHz	238.78mW
	LTE Band 5B Channel Bandwidth: 10MHz+5MHz	239.88mW
	LTE Band 5B Channel Bandwidth: 10MHz+10MHz	243.78mW
EMISSION DESIGNATORGOGN	WCDMA	4M15F9W
	LTE Band 5 Channel Bandwidth: 1.4MHz	QPSK: 1M09G7D 16QAM: 1M10W7D
	LTE Band 5 (Channel Bandwidth: 3MHz	QPSK: 2M69G7D 16QAM: 2M70W7D
	LTE Band 5 Channel Bandwidth: 5MHz	QPSK: 4M52G7D 16QAM: 4M51W7D
	LTE Band 5 Channel Bandwidth: 10MHz	QPSK: 8M97G7D 16QAM: 8M99W7D
	LTE Band 5B Channel Bandwidth: 3MHz+5MHz	QPSK: 7M49G7D 16QAM: 7M48W7D
	LTE Band 5B Channel Bandwidth: 5MHz+3MHz	QPSK: 7M49G7D 16QAM: 7M48W7D
	LTE Band 5B Channel Bandwidth: 5MHz+10MHz	QPSK: 13M9G7D 16QAM: 13M9W7D
	LTE Band 5B Channel Bandwidth: 10MHz+5MHz	QPSK: 13M9G7D 16QAM: 13M9W7D
	LTE Band 5B Channel Bandwidth: 10MHz+10MHz	QPSK: 18M8G7D 16QAM: 18M8W7D
ANTENNA TYPE	Monopole Antenna with 2.56dBi gain for WCDMA V/LTE B5/ CA 5B	
HW VERSION	P2.0	
SW VERSION	MODEM_GM_C3_3.0.2.24	
I/O PORTS	Refer to user's manual	
CABLE SUPPLIED	N/A	
EXTREME TEMPERATURE	-40-85 °C	



EXTREME VOLTAGE	3.8V - 4.2V
------------------------	-------------

NOTE:

1. For a more detailed features description, please refer to the manufacturer’s specifications or the user's manual.
2. The EUT incorporates a SISO function. Physically, the EUT provides one completed transmitters

MODULATION MODE	TX FUNCTION
WCDMA	1TX
LTE	1TX

3. For the test results, the EUT had been tested with all conditions. But only the worst case was shown in test report.
4. Antenna gain and EUT conducted cable loss are provided by the customer, and the laboratory will record the results based on these items that involve these two parameters.
5. According to the information provided by the manufacturer, The difference between FE5NAR110, FE5NAR111 is as follows:

Sample	HVIN/PMN	5G Bands NSA	5G Bands SA	SA UL MIMO	LTE Bands	UMTS	GNSS
1	FE5NAR110	n2, n5, n66, n77	n25, n41, n66, n71, n77	n41, n77	2, 4, 5, 7, 12, 13, 14, 28A, 28B, 29Rx, 30Rx, 66, 71	2, 4, 5	L1, L5
2	FE5NAR111	n2, n5, n66, n77	n25, n41, n66, n71, n77	n41, n77	2, 4, 5, 7, 12, 13, 14, 28A, 28B, 29Rx, 30Rx, 66, 71	2, 4, 5	L1



2.2 CONFIGURATION OF SYSTEM UNDER TEST FOR RADIATION EMISSION

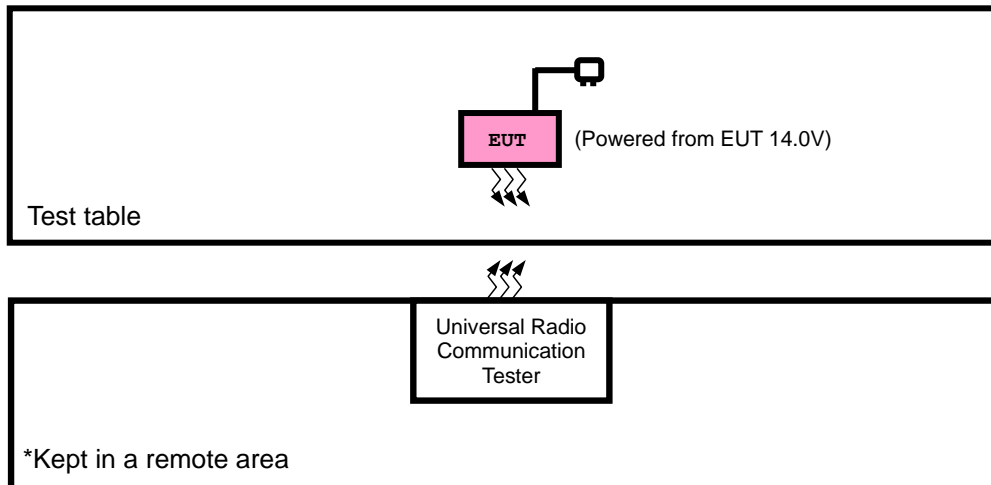



2.3 DESCRIPTION OF SUPPORT UNITS

The EUT has been tested as an independent unit together with other necessary accessories or support units. The following support units or accessories were used to form a representative test configuration during the tests.

NO.	PRODUCT	BRAND	MODEL NO.	SERIAL NO.	FCC ID
1	N/A	N/A	N/A	N/A	N/A

NO.	SIGNAL CABLE DESCRIPTION OF THE ABOVE SUPPORT UNITS
1	USB cable: Unshielded, Detachable 1.0m

2.4 TEST ITEM AND TEST CONFIGURATION

Pre-Scan has been conducted to determine the worst-case mode from all possible combinations between available modulations, data rates, XYZ axis and antenna ports. The worst case in ERP and radiated emission was found when positioned on X-plane for GSM /EDGE /LTE. Following channel(s) was (were) selected for the final test as listed below:

EUT CONFIGURE MODE	DESCRIPTION
A	EUT + DC Source with WCDMA or LTE link



WCDMA MODE

EUT CONFIGURE MODE	TEST ITEM	AVAILABLE CHANNEL	TESTED CHANNEL	MODE
A	ERP	4132 to 4233	4132, 4182, 4233	WCDMA
A	FREQUENCY STABILITY	4132 to 4233	4132, 4182, 4233	WCDMA
A	OCCUPIED BANDWIDTH	4132 to 4233	4132, 4182, 4233	WCDMA
A	BAND EDGE	4132 to 4233	4132, 4233	WCDMA
A	CONDUCTED EMISSION	4132 to 4233	4132, 4182, 4233	WCDMA
A	RADIATED EMISSION	4132 to 4233	4132, 4182, 4233	WCDMA
A	PEAK TO AVERAGE RATIO	4132 to 4233	4132, 4182, 4233	WCDMA

LTE BAND 5 MODE

EUT CONFIGURE MODE	TEST ITEM	Available Channel	Tested Channel	Channel bandwidth	modulation	mode
A	ERP	20407 to 20643	20407, 20525, 20643	1.4MHz	QPSK, 16QAM, 64QAM,	1 RB / 0 RB Offset
		20415 to 20635	20415, 20525, 20635	3MHz	QPSK, 16QAM, 64QAM	1 RB / 0 RB Offset
		20425 to 20625	20425, 20525, 20625	5MHz	QPSK, 16QAM, 64QAM	1 RB / 0 RB Offset
		20450 to 20600	20450, 20525, 20600	10MHz	QPSK, 16QAM, 64QAM	1 RB / 0 RB Offset
A	FREQUENCY STABILITY	20450 to 20600	20450, 20525, 20600	10MHz	QPSK	50 RB / 0 RB Offset
A	OCCUPIED BANDWIDTH	20407 to 20643	20407, 20525, 20643	1.4MHz	QPSK, 16QAM	6 RB / 0 RB Offset
		20415 to 20635	20415, 20525, 20635	3MHz	QPSK, 16QAM	15 RB / 0 RB Offset
		20425 to 20625	20425, 20525, 20625	5MHz	QPSK, 16QAM	25 RB / 0 RB Offset
		20450 to 20600	20450, 20525, 20600	10MHz	QPSK, 16QAM	50 RB / 0 RB Offset
A	BAND EDGE	20407 to 20643	20407	1.4 MHz	QPSK, 16QAM	1 RB / 0 RB Offset 6 RB / 0 RB Offset
		20407 to 20643	20643	1.4 MHz	QPSK, 16QAM	1 RB / 5 RB Offset 6 RB / 0 RB Offset
		20415 to 20635	20415	3 MHz	QPSK, 16QAM	1 RB / 0 RB Offset 15 RB / 0 RB Offset
		20415 to 20635	20635	3 MHz	QPSK, 16QAM	1 RB / 14 RB Offset 15 RB / 0 RB Offset
		20425 to	20425	5MHz	QPSK, 16QAM	1 RB / 0 RB Offset



		20625				25 RB / 0 RB Offset
		20425 to 20625	20625	5MHz	QPSK, 16QAM	1 RB / 24 RB Offset 25 RB / 0 RB Offset
		20450 to 20600	20450	10MHz	QPSK, 16QAM	1 RB / 0 RB Offset 50 RB / 0 RB Offset
		20450 to 20600	20600	10MHz	QPSK, 16QAM	1 RB / 49 RB Offset 50 RB / 0 RB Offset
A	CONDCUDED EMISSION	20407 to 20643	20407, 20525, 20643	1.4MHz	QPSK	1 RB / 0 RB Offset
		20415 to 20635	20415, 20525, 20635	3MHz	QPSK	1 RB / 0 RB Offset
		20425 to 20625	20425, 20525, 20625	5MHz	QPSK	1 RB / 0 RB Offset
		20450 to 20600	20450, 20525, 20600	10MHz	QPSK	1 RB / 0 RB Offset
A	RADIATED EMISSION	20407 to 20643	20525	1.4MHz	QPSK	1 RB / 0 RB Offset
		20415 to 20635	20415, 20525, 20635	3MHz	QPSK	1 RB / 0 RB Offset
		20425 to 20625	20525	5MHz	QPSK	1 RB / 0 RB Offset
		20450 to 20600	20525	10MHz	QPSK	1 RB / 0 RB Offset
A	PEAK TO AVERAGE RATIO	20407 to 20643	20407, 20525, 20643	1.4MHz	QPSK, 16QAM	1 RB / 0 RB Offset 6 RB / 0 RB Offset
		20415 to 20635	20415, 20525, 20635	3MHz	QPSK, 16QAM	1 RB / 0 RB Offset 15 RB / 0 RB Offset
		20425 to 20625	20425, 20525, 20625	5MHz	QPSK, 16QAM	1 RB / 0 RB Offset 25 RB / 0 RB Offset
		20450 to 20600	20450, 20525, 20600	10MHz	QPSK, 16QAM	1 RB / 0 RB Offset 50 RB / 0 RB Offset

Note: 1. This device was tested under all bandwidths, RB configurations and modulations. The worst case was found in QPSK modulation.



LTE BAND CA_5B MODE

EUT CONFIGURE MODE	TEST ITEM	AVAILABLE PCC CHANNEL	AVAILABLE SCC CHANNEL	TESTED CHANNEL	CHANNEL BANDWIDTH	MODULATION	MODE(PCC)	MODE(SCC)
A	ERP	20450 to 21501	20549 to 20600	Low, Middle, High	10MHz+10MHz	QPSK, 16QAM, 64QAM,	1RB/ 49RB Offset	1RB/ 0RB Offset
		20450 to 20550	20522 to 20622	Low, Middle, High	10MHz+5MHz	QPSK, 16QAM, 64QAM	1RB/ 49RB Offset	1RB/ 0RB Offset
		20428 to 20528	20500 to 20600	Low, Middle, High	5MHz+10MHz	QPSK, 16QAM, 64QAM	1RB/ 24RB Offset	1RB/ 0RB Offset
		20425 to 20595	20464 to 20634	Low, Middle, High	5MHz+3MHz	QPSK, 16QAM, 64QAM	1RB/ 24RB Offset	1RB/ 0RB Offset
		20416 to 20586	20455 to 20625	Low, Middle, High	3MHz+5MHz	QPSK, 16QAM, 64QAM	1RB/ 14RB Offset	1RB/ 0RB Offset
A	OCCUPIED BANDWIDTH	20450 to 21501	20549 to 20600	Low, Middle, High	10MHz+10MHz	QPSK, 16QAM	50RB/ 0RB Offset	50RB/ 0RB Offset
		20450 to 20550	20522 to 20622	Low, Middle, High	10MHz+5MHz	QPSK, 16QAM	25RB/ 0RB Offset	25RB/ 0RB Offset
		20428 to 20528	20500 to 20600	Low, Middle, High	5MHz+10MHz	QPSK, 16QAM	25RB/ 0RB Offset	50RB/ 0RB Offset
		20425 to 20595	20464 to 20634	Low, Middle, High	5MHz+3MHz	QPSK, 16QAM	25RB/ 0RB Offset	15RB/ 0RB Offset
		20416 to 20586	20455 to 20625	Low, Middle, High	3MHz+5MHz	QPSK, 16QAM	15RB/ 0RB Offset	25RB/ 0RB Offset
A	BAND EDGE	20450 to 21501	20549 to 20600	Low	10MHz+10MHz	QPSK, 16QAM	1RB/ 0RB Offset	1RB/ 49RB Offset
							1RB/ 49RB Offset	1RB/ 0RB Offset
							50RB/ 0RB Offset	50RB/ 0RB Offset
				High	10MHz+10MHz	QPSK, 16QAM	1RB/ 0RB Offset	1RB/ 49RB Offset
							1RB/ 49RB Offset	1RB/ 0RB Offset
							50RB/ 0RB Offset	50RB/ 0RB Offset
A	CONDUCTED EMISSION	20450 to 21501	20549 to 20600	Low, Middle, High	10MHz+10MHz	QPSK	1RB/ 49RB Offset	1RB/ 0RB Offset
A	RADIATED EMISSION	20450 to 21501	20549 to 20600	Low, Middle, High	10MHz+10MHz	QPSK	1RB/ 99RB Offset	1RB/ 0RB Offset

Note: 1.This device was tested under all bandwidths, RB configurations and modulations. The worst case was found in QPSK modulation.



TEST CONDITION:

TEST ITEM	ENVIRONMENTAL CONDITIONS	INPUT POWER	TESTED BY
ERP	23deg. C, 70%RH	DC 14.0V	Jace Hu
FREQUENCY STABILITY	23deg. C, 70%RH	DC 12V/14V/16V	James Fu
OCCUPIED BANDWIDTH	23deg. C, 70%RH	DC 14.0V	James Fu
BAND EDGE	23deg. C, 70%RH	DC 14.0V	James Fu
CONDUCTED EMISSION	23deg. C, 70%RH	DC 14.0V	James Fu
RADIATED EMISSION	23deg. C, 70%RH	DC 14.0V	Jace Hu
PEAK TO AVERAGE RATIO	23deg. C, 70%RH	DC 14.0V	James Fu

2.5 EUT OPERATING CONDITIONS

The EUT makes a call to the communication simulator. The communication simulator station system controlled a EUT to export maximum output power under transmission mode and specific channel frequency.



**BUREAU
VERITAS**

Test Report No.: W7L-240430W002RF02

2.6 GENERAL DESCRIPTION OF APPLIED STANDARDS

The EUT is a RF product. According to the specifications of the manufacturer, it must comply with the requirements of the following standards:

FCC 47 CFR Part 2

FCC 47 CFR Part 22

KDB 971168 D01 Power Meas License Digital Systems v03r01

ANSI/TIA/EIA-603-D

ANSI/TIA/EIA-603-E

ANSI C63.26-2015

NOTE: All test items have been performed and recorded as per the above standards.

3 TEST TYPES AND RESULTS

3.1 OUTPUT POWER MEASUREMENT

3.1.1 LIMITS OF OUTPUT POWER MEASUREMENT

Mobile / Portable station are limited to 7 watts e.r.p.

3.1.2 TEST PROCEDURES

EIRP / ERP MEASUREMENT:

Per KDB 971168 D01 Power Meas License Digital Systems v03r01 or subclause 5.2.5.5 of ANSI C63.26-2015, the relevant equation for determine the ERP or EIRP from the conducted RF output power measured using the guidance provided above is:

$$\text{ERP or EIRP} = P_{\text{Meas}} + G_{\text{T}} - L_{\text{C}}$$

Where:

ERP or EIRP = effective radiated power or equivalent isotopically radiated power, respectively

(expressed in the same units as P_{Meas} , typically dBW or dBm);

P_{Meas} = measured transmitter output power or PSD, in dBm or dBW;

G_{T} = gain of the transmitting antenna, in dBd (ERP) or dBi (EIRP);

L_{C} = signal attenuation in the connecting cable between the transmitter and antenna, in dB.

CONDUCTED POWER MEASUREMENT:

The EUT was set up for the maximum power with WCDMA link data modulation and link up with simulator. Set the EUT to transmit under low, middle and high channel and record the power level shown on simulator.



3.1.3 TEST SETUP

EIRP / ERP Measurement:

CONDUCTED POWER MEASUREMENT:





3.1.4 TEST RESULTS

CONDUCTED OUTPUT POWER (dBm)

Band	WCDMA V		
	4132	4182	4233
TX Channel	4132	4182	4233
Rx Channel	4357	4407	4458
Frequency (MHz)	826.4	836.4	846.6
RMC 12.2K	23.05	23.14	23.09
HSDPA Subtest-1	21.70	21.80	21.87
HSDPA Subtest-2	21.54	21.71	21.93
HSDPA Subtest-3	21.04	21.19	21.36
HSDPA Subtest-4	21.28	21.11	21.40
DC-HSDPA Subtest-1	21.65	21.72	21.87
DC-HSDPA Subtest-2	21.51	21.69	21.88
DC-HSDPA Subtest-3	21.12	21.31	21.37
DC-HSDPA Subtest-4	21.05	21.24	21.42
HSUPA Subtest-1	21.58	21.68	21.90
HSUPA Subtest-2	19.52	19.62	19.82
HSUPA Subtest-3	20.49	20.53	20.80
HSUPA Subtest-4	19.58	19.54	19.71
HSUPA Subtest-5	21.49	21.70	21.87



LTE Band 5

LTE Band 5						
BW	Modulation	RB Size	RB Offset	Low	Mid	High
		Channel		20450	20525	20600
		Frequency (MHz)		829	836.5	844
10M	QPSK	1	0	23.06	23.12	23.13
		1	24	23.16	23.22	23.15
		1	49	23.09	23.13	23.09
		25	0	22.19	22.18	22.16
		25	12	22.08	22.28	22.27
		25	25	22.12	22.26	22.23
		50	0	21.95	22.06	22.03
	16QAM	1	0	22.44	22.45	22.45
		1	24	22.39	22.51	22.49
		1	49	22.39	22.46	22.51
		25	0	21.07	21.18	21.18
		25	12	21.08	21.21	21.23
		25	25	21.12	21.19	21.31
		50	0	21.09	21.08	21.15
	64QAM	1	0	21.30	21.39	21.40
		1	24	21.40	21.41	21.37
		1	49	21.35	21.33	21.43
		25	0	20.09	20.25	20.26
		25	12	20.12	20.30	20.24
		25	25	20.13	20.30	20.30
		50	0	20.11	20.13	20.19



BW	Modulation	Channel		20425	20525	20625
		Frequency (MHz)		826.5	836.5	846.5
5M	QPSK	1	0	22.92	23.04	23.06
		1	12	23.05	23.15	23.14
		1	24	22.99	22.99	23.01
		12	0	22.12	22.08	22.14
		12	6	21.94	22.16	22.19
		12	13	21.97	22.13	22.12
		25	0	21.94	21.97	22.02
	16QAM	1	0	22.37	22.35	22.33
		1	12	22.35	22.46	22.41
		1	24	22.32	22.40	22.43
		12	0	21.05	21.13	21.15
		12	6	20.93	21.20	21.08
		12	13	21.02	21.14	21.22
		25	0	21.04	21.01	21.00
	64QAM	1	0	21.17	21.38	21.30
		1	12	21.26	21.32	21.34
		1	24	21.25	21.28	21.28
		12	0	20.05	20.13	20.11
		12	6	20.07	20.28	20.11
		12	13	20.01	20.18	20.23
		25	0	20.05	20.11	20.07



BW	Modulation	Channel		20415	20525	20635
		Frequency (MHz)		825.5	836.5	847.5
3M	QPSK	1	0	23.03	23.06	23.07
		1	7	23.05	23.15	23.05
		1	14	22.96	23.03	23.01
		8	0	22.12	22.04	22.04
		8	3	22.01	22.22	22.19
		8	7	22.08	22.17	22.17
		15	0	21.88	21.92	21.92
	16QAM	1	0	22.41	22.40	22.41
		1	7	22.35	22.47	22.35
		1	14	22.34	22.41	22.50
		8	0	21.06	21.09	21.10
		8	3	20.99	21.18	21.12
		8	7	21.09	21.10	21.17
		15	0	21.07	20.95	21.05
	64QAM	1	0	21.23	21.32	21.28
		1	7	21.39	21.38	21.34
		1	14	21.31	21.31	21.40
		8	0	19.94	20.11	20.11
		8	3	20.07	20.17	20.12
		8	7	20.08	20.24	20.16
		15	0	20.05	20.04	20.07



BW	Modulation	Channel		20407	20525	20643
		Frequency (MHz)		824.7	836.5	848.3
1.4M	QPSK	1	0	23.00	22.99	23.05
		1	2	23.09	23.20	23.03
		1	5	23.05	23.04	23.01
		3	0	23.04	23.08	23.10
		3	1	22.93	23.13	23.13
		3	3	22.97	23.23	23.15
		6	0	21.94	21.98	21.90
	16QAM	1	0	22.38	22.33	22.33
		1	2	22.34	22.43	22.34
		1	5	22.24	22.39	22.42
		3	0	22.06	22.15	22.16
		3	1	21.99	22.08	22.10
		3	3	22.05	22.07	22.29
		6	0	21.08	20.94	21.06
	64QAM	1	0	21.19	21.31	21.31
		1	2	21.33	21.37	21.34
		1	5	21.20	21.22	21.35
		3	0	20.98	21.24	21.24
		3	1	21.09	21.15	21.10
		3	3	21.12	21.18	21.23
		6	0	20.04	20.00	20.10



CA_5B

CA_5B									
Combination 10MHz+10MHz (50RB+50RB)									
PCC Channel	PCC Frequency (MHz)	SCC Channel	SCC Frequency (MHz)	Modulation	PCC		SCC		Measured Power (dBm)
					RB Size	RB offset	RB Size	RB offset	
20450	829	20549	838.9	QPSK	1	49	1	0	23.27
				16QAM	1	49	1	0	22.60
				64QAM	1	49	1	0	21.56
20476	831.6	20575	841.5	QPSK	1	49	1	0	23.46
				16QAM	1	49	1	0	22.81
				64QAM	1	49	1	0	21.84
20501	834.1	20600	844	QPSK	1	49	1	0	23.43
				16QAM	1	49	1	0	22.74
				64QAM	1	49	1	0	21.70
Combination 10MHz+5MHz (50RB+25RB)									
PCC Channel	PCC Frequency (MHz)	SCC Channel	SCC Frequency (MHz)	Modulation	PCC		SCC		Measured Power (dBm)
					RB Size	RB offset	RB Size	RB offset	
20450	829	20522	836.2	QPSK	1	49	1	0	23.26
				16QAM	1	49	1	0	22.49
				64QAM	1	49	1	0	21.49
20500	834	20572	841.2	QPSK	1	49	1	0	23.36
				16QAM	1	49	1	0	22.79
				64QAM	1	49	1	0	21.81
20550	839	20622	846.2	QPSK	1	49	1	0	23.39
				16QAM	1	49	1	0	22.66
				64QAM	1	49	1	0	21.66
Combination 5MHz+10MHz (25RB+50RB)									
PCC Channel	PCC Frequency (MHz)	SCC Channel	SCC Frequency (MHz)	Modulation	PCC		SCC		Measured Power (dBm)
					RB Size	RB offset	RB Size	RB offset	
20428	826.8	20500	834	QPSK	1	24	1	0	23.16
				16QAM	1	24	1	0	22.59
				64QAM	1	24	1	0	21.45
20478	831.8	20550	839	QPSK	1	24	1	0	23.35
				16QAM	1	24	1	0	22.69
				64QAM	1	24	1	0	21.79
20528	836.8	20600	844	QPSK	1	24	1	0	23.37
				16QAM	1	24	1	0	22.67
				64QAM	1	24	1	0	21.65



Combination 5MHz+3MHz (25RB+15RB)									
PCC Channel	PCC Frequency (MHz)	SCC Channel	SCC Frequency (MHz)	Modulation	PCC		SCC		Measured Power (dBm)
					RB Size	RB offset	RB Size	RB offset	
20425	826.5	20464	830.4	QPSK	1	24	1	0	23.27
				16QAM	1	24	1	0	22.49
				64QAM	1	24	1	0	21.47
20510	835	20549	838.9	QPSK	1	24	1	0	23.42
				16QAM	1	24	1	0	22.75
				64QAM	1	24	1	0	21.79
20595	843.5	20634	847.4	QPSK	1	24	1	0	23.39
				16QAM	1	24	1	0	22.74
				64QAM	1	24	1	0	21.62
Combination 3MHz+5MHz (15RB+25RB)									
PCC Channel	PCC Frequency (MHz)	SCC Channel	SCC Frequency (MHz)	Modulation	PCC		SCC		Measured Power (dBm)
					RB Size	RB offset	RB Size	RB offset	
20416	825.6	20455	829.5	QPSK	1	14	1	0	23.24
				16QAM	1	14	1	0	22.59
				64QAM	1	14	1	0	21.44
20501	834.1	20540	838	QPSK	1	14	1	0	23.35
				16QAM	1	14	1	0	22.78
				64QAM	1	14	1	0	21.76
20586	842.6	20625	846.5	QPSK	1	14	1	0	23.34
				16QAM	1	14	1	0	22.71
				64QAM	1	14	1	0	21.68



CA_5B									
Combination 5MHz+10MHz (25RB+50RB)									
PCC Channel	PCC Frequency (MHz)	SCC Channel	SCC Frequency (MHz)	Modulation	PCC		SCC		Measured Power (dBm)
					RB Size	RB offset	RB Size	RB offset	
20428	826.8	20500	834	QPSK	1	24	1	0	22.27
				16QAM	1	24	1	0	21.60
				64QAM	1	24	1	0	20.49
				256QAM	1	24	1	0	17.41
20478	831.8	20550	839	QPSK	1	24	1	0	22.14
				16QAM	1	24	1	0	21.64
				64QAM	1	24	1	0	20.78
				256QAM	1	24	1	0	17.70
20528	836.8	20600	844	QPSK	1	24	1	0	22.14
				16QAM	1	24	1	0	21.56
				64QAM	1	24	1	0	20.71
				256QAM	1	24	1	0	17.61
Combination 5MHz+3MHz (25RB+15RB)									
PCC Channel	PCC Frequency (MHz)	SCC Channel	SCC Frequency (MHz)	Modulation	PCC		SCC		Measured Power (dBm)
					RB Size	RB offset	RB Size	RB offset	
20425	826.5	20464	830.4	QPSK	1	24	1	0	22.38
				16QAM	1	24	1	0	21.53
				64QAM	1	24	1	0	20.52
				256QAM	1	24	1	0	17.51
20510	835	20549	838.9	QPSK	1	24	1	0	22.12
				16QAM	1	24	1	0	21.68
				64QAM	1	24	1	0	20.77
				256QAM	1	24	1	0	17.61
20595	843.5	20634	847.4	QPSK	1	24	1	0	22.14
				16QAM	1	24	1	0	21.49
				64QAM	1	24	1	0	20.70
				256QAM	1	24	1	0	17.68



CA_5B									
Combination 3MHz+5MHz (15RB+25RB)									
PCC Channel	PCC Frequency (MHz)	SCC Channel	SCC Frequency (MHz)	Modulation	PCC		SCC		Measured Power (dBm)
					RB Size	RB offset	RB Size	RB offset	
20416	825.6	20455	829.5	QPSK	1	14	1	0	22.31
				16QAM	1	14	1	0	21.58
				64QAM	1	14	1	0	20.54
				256QAM	1	14	1	0	17.49
20501	834.1	20540	838	QPSK	1	14	1	0	22.22
				16QAM	1	14	1	0	21.65
				64QAM	1	14	1	0	20.79
				256QAM	1	14	1	0	17.64
20586	842.6	20625	846.5	QPSK	1	14	1	0	22.27
				16QAM	1	14	1	0	21.50
				64QAM	1	14	1	0	20.68
				256QAM	1	14	1	0	17.67



ERP POWER (dBm)

WCDMA V

WCDMA V						
Channel	Frequency (MHz)	Conducted Power (dBm)	Gain (dBi)	ERP (dBm)	ERP (mW)	Limit (W)
4132	826.4	23.05	2.56	23.46	221.82	7
4182	836.4	23.14	2.56	23.55	226.46	7
4233	846.6	23.09	2.56	23.5	223.87	7

LTE BAND 5

LTE B5 1.4M QPSK						
Channel	Frequency (MHz)	Conducted Power (dBm)	Gain (dBi)	ERP (dBm)	ERP (mW)	Limit (W)
20407	824.7	23.09	2.56	23.5	223.87	7
20525	836.5	23.23	2.56	23.64	231.21	7
20643	848.3	23.15	2.56	23.56	226.99	7

LTE B5 1.4M 16QAM						
Channel	Frequency (MHz)	Conducted Power (dBm)	Gain (dBi)	ERP (dBm)	ERP (mW)	Limit (W)
20407	824.7	22.38	2.56	22.79	190.11	7
20525	836.5	22.43	2.56	22.84	192.31	7
20643	848.3	22.42	2.56	22.83	191.87	7

LTE B5 1.4M 64QAM						
Channel	Frequency (MHz)	Conducted Power (dBm)	Gain (dBi)	ERP (dBm)	ERP (mW)	Limit (W)
20407	824.7	21.33	2.56	21.74	149.28	7
20525	836.5	21.37	2.56	21.78	150.66	7
20643	848.3	21.35	2.56	21.76	149.97	7



LTE B5 3M QPSK						
Channel	Frequency (MHz)	Conducted Power (dBm)	Gain (dBi)	ERP (dBm)	ERP (mW)	Lmit (W)
20415	825.5	23.05	2.56	23.46	221.82	7
20525	836.5	23.15	2.56	23.56	226.99	7
20635	847.5	23.07	2.56	23.48	222.84	7

LTE B5 3M 16QAM						
Channel	Frequency (MHz)	Conducted Power (dBm)	Gain (dBi)	ERP (dBm)	ERP (mW)	Lmit (W)
20415	825.5	22.41	2.56	22.82	191.43	7
20525	836.5	22.47	2.56	22.88	194.09	7
20635	847.5	22.5	2.56	22.91	195.43	7

LTE B5 3M 64QAM						
Channel	Frequency (MHz)	Conducted Power (dBm)	Gain (dBi)	ERP (dBm)	ERP (mW)	Lmit (W)
20415	825.5	21.39	2.56	21.8	151.36	7
20525	836.5	21.38	2.56	21.79	151.01	7
20635	847.5	21.4	2.56	21.81	151.71	7



LTE B5 5M QPSK						
Channel	Frequency (MHz)	Conducted Power (dBm)	Gain (dBi)	ERP (dBm)	ERP (mW)	Lmit (W)
20425	826.5	23.05	2.56	23.46	221.82	7
20525	836.5	23.15	2.56	23.56	226.99	7
20625	846.5	23.14	2.56	23.55	226.46	7

LTE B5 5M 16QAM						
Channel	Frequency (MHz)	Conducted Power (dBm)	Gain (dBi)	ERP (dBm)	ERP (mW)	Lmit (W)
20425	826.5	22.37	2.56	22.78	189.67	7
20525	836.5	22.46	2.56	22.87	193.64	7
20625	846.5	22.43	2.56	22.84	192.31	7

LTE B5 5M 64QAM						
Channel	Frequency (MHz)	Conducted Power (dBm)	Gain (dBi)	ERP (dBm)	ERP (mW)	Lmit (W)
20425	826.5	21.26	2.56	21.67	146.89	7
20525	836.5	21.38	2.56	21.79	151.01	7
20625	846.5	21.34	2.56	21.75	149.62	7



LTE B5 10M QPSK						
Channel	Frequency (MHz)	Conducted Power (dBm)	Gain (dBi)	ERP (dBm)	ERP (mW)	Lmit (W)
20450	829	23.16	2.56	23.57	227.51	7
20525	836.5	23.22	2.56	23.63	230.67	7
20600	844	23.15	2.56	23.56	226.99	7

LTE B5 10M 16QAM						
Channel	Frequency (MHz)	Conducted Power (dBm)	Gain (dBi)	ERP (dBm)	ERP (mW)	Lmit (W)
20450	829	22.44	2.56	22.85	192.75	7
20525	836.5	22.51	2.56	22.92	195.88	7
20600	844	22.51	2.56	22.92	195.88	7

LTE B5 10M 64QAM						
Channel	Frequency (MHz)	Conducted Power (dBm)	Gain (dBi)	ERP (dBm)	ERP (mW)	Lmit (W)
20450	829	21.4	2.56	21.81	151.71	7
20525	836.5	21.41	2.56	21.82	152.05	7
20600	844	21.43	2.56	21.84	152.76	7

REMARKS: ERP Output Power (dBm) = EIRP (dBm) -2.15(dB).



BUREAU
VERITAS

Test Report No.: W7L-240430W002RF02

LTE CA_5B

CA_5B

Combination 10MHz+10MHz (50RB+50RB)

PCC Channel	PCC Frequency (MHz)	SCC Channel	SCC Frequency (MHz)	Modulation	PCC		SCC		Measured Power (dBm)	Gain (dBi)	ERP(dBm)	ERP(mW)	Limit (W)
					RB Size	RB offset	RB Size	RB offset					
20450	829	20549	838.9	QPSK	1	49	1	0	23.27	2.56	23.68	233.35	7
				16QAM	1	49	1	0	22.60	2.56	23.01	199.99	7
				64QAM	1	49	1	0	21.56	2.56	21.97	157.40	7
20476	831.6	20575	841.5	QPSK	1	49	1	0	23.46	2.56	23.87	243.78	7
				16QAM	1	49	1	0	22.81	2.56	23.22	209.89	7
				64QAM	1	49	1	0	21.84	2.56	22.25	167.88	7
20501	834.1	20600	844	QPSK	1	49	1	0	23.43	2.56	23.84	242.10	7
				16QAM	1	49	1	0	22.74	2.56	23.15	206.54	7
				64QAM	1	49	1	0	21.70	2.56	22.11	162.55	7



BUREAU
VERITAS

Test Report No.: W7L-240430W002RF02

Combination 10MHz+5MHz (50RB+25RB)													
PCC Channel	PCC Frequency (MHz)	SCC Channel	SCC Frequency (MHz)	Modulation	PCC		SCC		Measured Power (dBm)	Gain (dBi)	ERP(dBm)	ERP(mW)	Limit (W)
					RB Size	RB offset	RB Size	RB offset					
20450	829	20522	836.2	QPSK	1	49	1	0	23.26	2.56	23.67	232.81	7
				16QAM	1	49	1	0	22.49	2.56	22.90	194.98	7
				64QAM	1	49	1	0	21.49	2.56	21.90	154.88	7
20500	834	20572	841.2	QPSK	1	49	1	0	23.36	2.56	23.77	238.23	7
				16QAM	1	49	1	0	22.79	2.56	23.20	208.93	7
				64QAM	1	49	1	0	21.81	2.56	22.22	166.72	7
20550	839	20622	846.2	QPSK	1	49	1	0	23.39	2.56	23.80	239.88	7
				16QAM	1	49	1	0	22.66	2.56	23.07	202.77	7
				64QAM	1	49	1	0	21.66	2.56	22.07	161.06	7



BUREAU
VERITAS

Test Report No.: W7L-240430W002RF02

Combination 5MHz+10MHz (25RB+50RB)													
PCC Channel	PCC Frequency (MHz)	SCC Channel	SCC Frequency (MHz)	Modulation	PCC		SCC		Measured Power (dBm)	Gain (dBi)	ERP(dBm)	ERP(mW)	Limit (W)
					RB Size	RB offset	RB Size	RB offset					
20428	826.8	20500	834	QPSK	1	24	1	0	23.16	2.56	23.57	227.51	7
				16QAM	1	24	1	0	22.59	2.56	23.00	199.53	7
				64QAM	1	24	1	0	21.45	2.56	21.86	153.46	7
20478	831.8	20550	839	QPSK	1	24	1	0	23.35	2.56	23.76	237.68	7
				16QAM	1	24	1	0	22.69	2.56	23.10	204.17	7
				64QAM	1	24	1	0	21.79	2.56	22.20	165.96	7
20528	836.8	20600	844	QPSK	1	24	1	0	23.37	2.56	23.78	238.78	7
				16QAM	1	24	1	0	22.67	2.56	23.08	203.24	7
				64QAM	1	24	1	0	21.65	2.56	22.06	160.69	7



BUREAU
VERITAS

Test Report No.: W7L-240430W002RF02

Combination 5MHz+3MHz (25RB+15RB)													
PCC Channel	PCC Frequency (MHz)	SCC Channel	SCC Frequency (MHz)	Modulation	PCC		SCC		Measured Power (dBm)	Gain (dBi)	ERP(dBm)	ERP(mW)	Limit (W)
					RB Size	RB offset	RB Size	RB offset					
20425	826.5	20464	830.4	QPSK	1	24	1	0	23.27	2.56	23.68	233.35	7
				16QAM	1	24	1	0	22.49	2.56	22.90	194.98	7
				64QAM	1	24	1	0	21.47	2.56	21.88	154.17	7
20510	835	20549	838.9	QPSK	1	24	1	0	23.42	2.56	23.83	241.55	7
				16QAM	1	24	1	0	22.75	2.56	23.16	207.01	7
				64QAM	1	24	1	0	21.79	2.56	22.20	165.96	7
20595	843.5	20634	847.4	QPSK	1	24	1	0	23.39	2.56	23.80	239.88	7
				16QAM	1	24	1	0	22.74	2.56	23.15	206.54	7
				64QAM	1	24	1	0	21.62	2.56	22.03	159.59	7



BUREAU
VERITAS

Test Report No.: W7L-240430W002RF02

Combination 3MHz+5MHz (15RB+25RB)													
PCC Channel	PCC Frequency (MHz)	SCC Channel	SCC Frequency (MHz)	Modulation	PCC		SCC		Measured Power (dBm)	Gain (dBi)	ERP(dBm)	ERP(mW)	Limit (W)
					RB Size	RB offset	RB Size	RB offset					
20416	825.6	20455	829.5	QPSK	1	14	1	0	23.24	2.56	23.65	231.74	7
				16QAM	1	14	1	0	22.59	2.56	23.00	199.53	7
				64QAM	1	14	1	0	21.44	2.56	21.85	153.11	7
20501	834.1	20540	838	QPSK	1	14	1	0	23.35	2.56	23.76	237.68	7
				16QAM	1	14	1	0	22.78	2.56	23.19	208.45	7
				64QAM	1	14	1	0	21.76	2.56	22.17	164.82	7
20586	842.6	20625	846.5	QPSK	1	14	1	0	23.34	2.56	23.75	237.14	7
				16QAM	1	14	1	0	22.71	2.56	23.12	205.12	7
				64QAM	1	14	1	0	21.68	2.56	22.09	161.81	7



3.2 FREQUENCY STABILITY MEASUREMENT

3.2.1 LIMITS OF FREQUENCY STABILITY MEASUREMENT

1.5 ppm is for base and fixed station. 2.5 ppm is for mobile station.

3.2.2 TEST PROCEDURE

- Device is placed at the oven room. The oven room could control the temperatures and humidity. Power warm up is at least 15 min and power applied should perform before recording frequency error.
- EUT is connected the external power supply to control the DC input power. The test voltage range is from minimum to maximum working voltage. Each step shall be record the frequency error rate.
- The temperature range step is 10 degrees in this test items. All temperature levels shall be hold the $\pm 0.5^{\circ}\text{C}$ during the measurement testing. The each temperature step shall be at least 0.5 hours, consider the EUT could be test under the stability condition.

NOTE: The frequency error was recorded frequency error from the communication simulator.

3.2.3 TEST SETUP

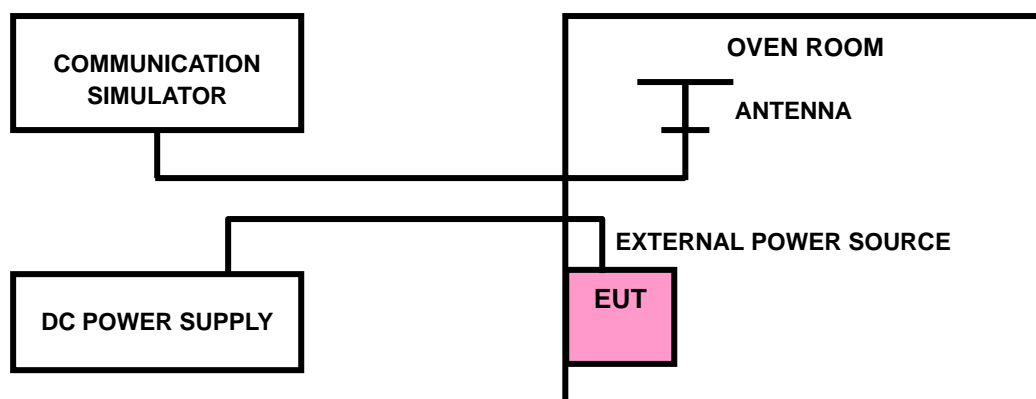



**BUREAU
VERITAS**

Test Report No.: W7L-240430W002RF02

3.2.4 TEST RESULTS

Please Refer to Appendix B Of this test report.

Note: VL = Low voltage(3.8V); VN/NV = Normal voltage(4V); VH = High voltage(4.2V);
NT = Normal temperature (25°C)



3.3 OCCUPIED BANDWIDTH MEASUREMENT

3.3.1 LIMITS OF OCCUPIED BANDWIDTH MEASUREMENT

The width of a frequency band such that, below the lower and above the upper frequency limits, the mean powers emitted are each equal to a specified percentage. 0.5 % of the total mean power of a given emission.

3.3.2 TEST SETUP

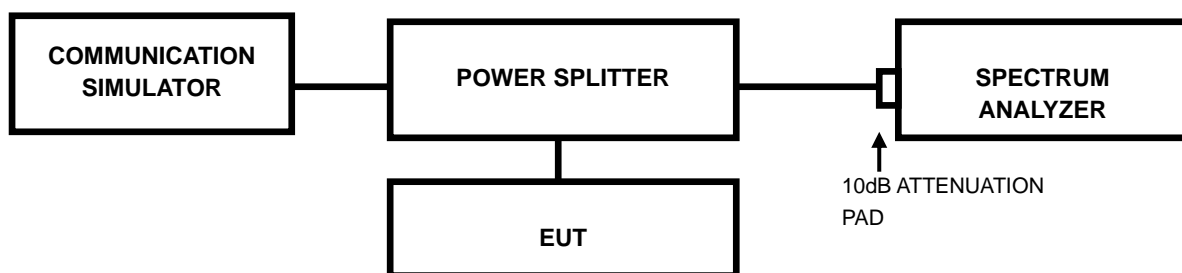

3.3.3 TEST PROCEDURES

- The conducted occupied bandwidth used the power splitter via EUT RF power connector between simulation base station and spectrum analyzer.
- Use OBW measurement function of Spectrum analyzer to measure 99 % occupied bandwidth.



Test Report No.: W7L-240430W002RF02

3.3.4 TEST RESULTS

Please Refer to Appendix B Of this test report.

3.4 BAND EDGE MEASUREMENT

3.4.1 LIMITS OF BAND EDGE MEASUREMENT

Power of any emission outside of the authorized operating frequency ranges must be attenuated below the transmitting power (P) by a factor of at least $43 + 10 \log(P)$ dB. In the 1 MHz bands immediately outside and adjacent to the frequency block a resolution bandwidth of at least one percent of the emission bandwidth of the fundamental emission of the transmitter may be employed.

3.4.2 TEST SETUP

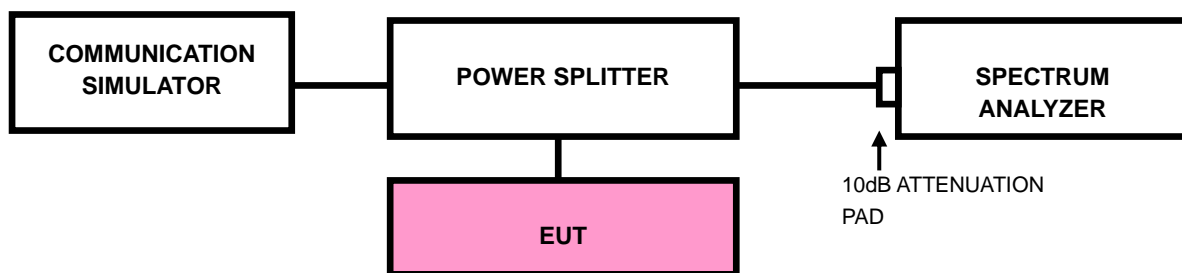



3.4.3 TEST PROCEDURES

- a) All measurements were done at low and high operational frequency range
- b) Connect the transmitter to the spectrum analyzer via coaxial cable while ensuring proper impedance matching.
- c) Tune the analyzer to the nominal center frequency of the emission bandwidth (EBW)
- d) .Set the resolution bandwidth (RBW) $\geq 1\%$ EBW in the 1MHz band immediately outside and adjacent to the band edge.
- e) Beyond the 1MHz band from the band edge, RBW=1MHz was used.
- f) Set the video bandwidth (VBW) to $\geq 3 \times$ RBW.
- g) Select the average power (RMS) display detector.
- h) Set the number of measurement points to ≥ 1001 .
- i) Use auto-coupled sweep time.
- j) Perform the measurement over an interval of time when the transmission is continuous and at its maximum power level.
- k) The RF fundamental frequency should be excluded against the limit line in the operating frequency band and use RBW is 10KHz or 100KHz.
- l) Record the max trace plot into the test report.



**BUREAU
VERITAS**

Test Report No.: W7L-240430W002RF02

3.4.4 TEST RESULTS

Please Refer to Appendix B Of this test report.



3.5 CONDUCTED SPURIOUS EMISSIONS

3.5.1 LIMITS OF CONDUCTED SPURIOUS EMISSIONS MEASUREMENT

The power of any emission outside of the authorized operating frequency ranges must be attenuated below the transmitting power (P) by a factor of at least $43 + 10 \log(P)$ dB. The emission limit equal to -13dBm .

3.5.2 TEST PROCEDURE

- The EUT makes a phone call to the communication simulator. All measurements were done at low, middle and high operational frequency range.
- Measuring frequency range is from 9kHz up to a frequency including its 10th harmonic. 10dB attenuation pad is connected with spectrum. RBW=1MHz and VBW=3MHz is used for conducted emission measurement.

3.5.3 TEST SETUP

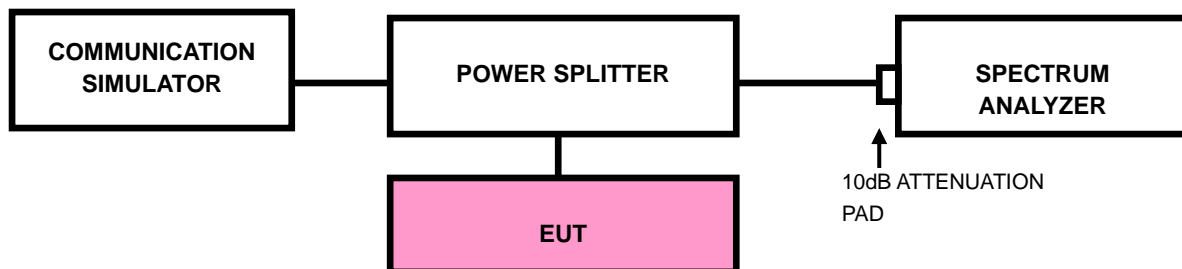



**BUREAU
VERITAS**

Test Report No.: W7L-240430W002RF02

3.5.4 TEST RESULTS

NOTE : The 9K~30MHz amplitude of spurious emissions attenuated more than 20 dB below the permissible value is not required in the report.

Please Refer to Appendix B Of this test report.



3.6 RADIATED EMISSION MEASUREMENT

3.6.1 LIMITS OF RADIATED EMISSION MEASUREMENT

The power of any emission outside of the authorized operating frequency ranges must be attenuated below the transmitting power (P) by a factor of at least $43 + 10 \log(P)$ dB. The emission limit equal to -13dBm .

3.6.2 TEST PROCEDURES

- a. Substitution method is used for E.I.R.P measurement. In the semi-anechoic chamber, EUT placed on the 0.8m height of Turn Table, rotated the table around 360 degrees to search the maximum radiation power and receiver antenna shall be rotated vertical and horizontal polarization and moved height from 1m to 4m to find the maximum polar radiated power. The "Read Value" is the spectrum reading the maximum power value.
- b. The substitution horn antenna is substituted for EUT at the same position and signals generator export the CW signal to the substitution antenna via a TX cable. Rotated the Turn Table and moved receiving antenna to find the maximum radiation power. Adjust output power level of S.G to get a Value of spectrum reading equal to "Read Value " of step a. Record the power level of S.G
- c. $\text{EIRP} = \text{Output power level of S.G} - \text{TX cable loss} + \text{Antenna gain of substitution horn.}$
- d. E.R.P power can be calculated form E.I.R.P power by subtracting the gain of dipole,
 $\text{E.R.P power} = \text{E.I.P.R power} - 2.15\text{dBi.}$

NOTE: The resolution bandwidth and video bandwidth of test receiver/spectrum analyzer is 1MHz/3MHz.

3.6.3 DEVIATION FROM TEST STANDARD

No deviation



3.6.4 TEST SETUP

< Frequency Range below 30MHz >

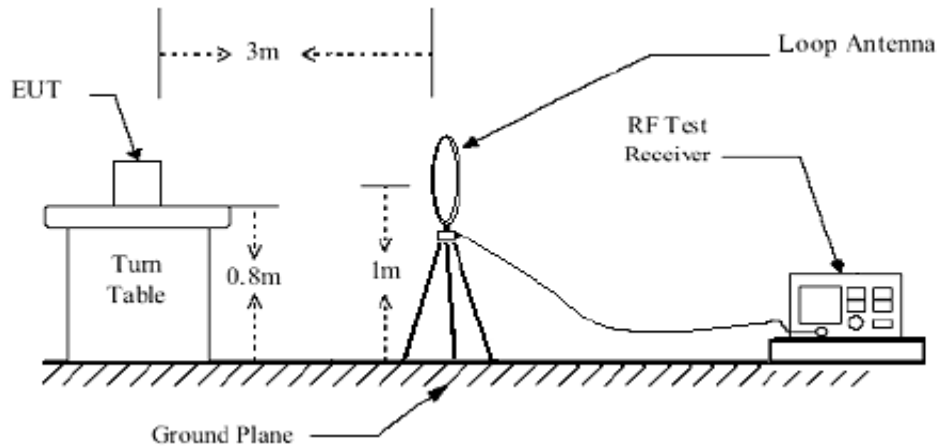

< Frequency Range 30MHz~1GHz >

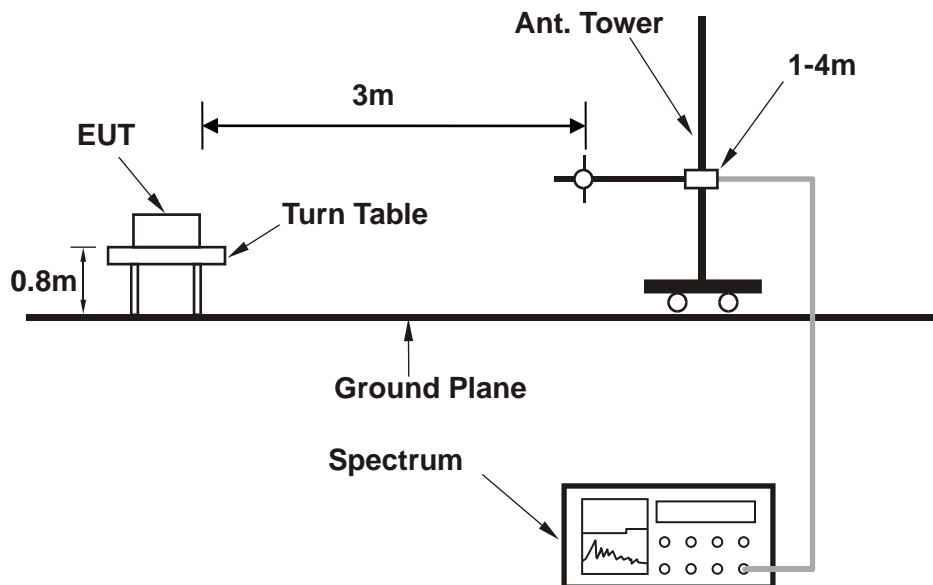



<Frequency Range above 1GHz>

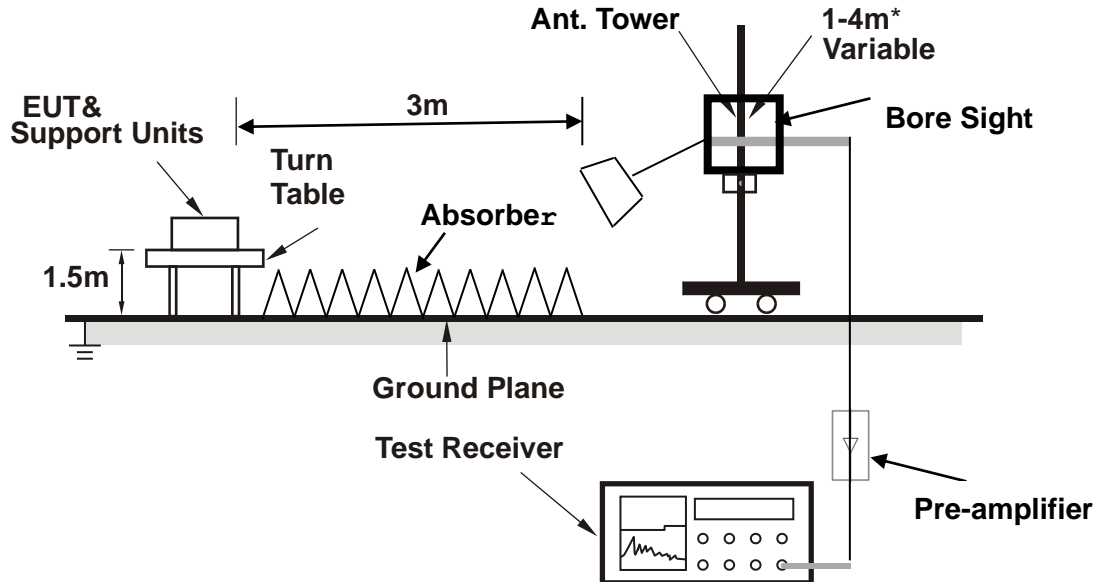

Note: Above 1G is a directional antenna

Depends on the EUT height and the antenna 3dB beamwidth both, refer to section 7.3 of CISPR 16-2-3.

For the actual test configuration, please refer to the attached file (Test Setup Photo).



3.6.5 TEST RESULTS

NOTE :

1. The 9K~30MHz amplitude of spurious emissions attenuated more than 20 dB below the permissible value is not required in the report.
2. For CA band, stricter limit is used for the results' evaluation.

BELOW 1GHz WORST-CASE DATA

30 MHz – 1GHz data:

WCDMA B5:

CHANNEL BANDWIDTH: 4132~4233 / QPSK

MODE	TX channel 4182	FREQUENCY RANGE	Below 1000MHz
ENVIRONMENTAL CONDITIONS	23deg. C, 70%RH	INPUT POWER	DC 14V
TESTED BY	Jace Hu		
ANTENNA POLARITY & TEST DISTANCE: HORIZONTAL AT 3 M			

	Freq	Level	Read Level	Limit Line	Over Limit	Factor	Remark	Pol/Phase
	MHz	dBm/m	dBm	dBm/m	dB	dB/m		
1	31.940	-55.28	-52.24	-13.00	-42.28	-3.04	Peak	Horizontal
2	57.160	-51.75	-39.65	-13.00	-38.75	-12.10	Peak	Horizontal
3	88.200	-59.53	-46.80	-13.00	-46.53	-12.73	Peak	Horizontal
4	148.340	-66.11	-51.69	-13.00	-53.11	-14.42	Peak	Horizontal
5	348.160	-67.77	-59.87	-13.00	-54.77	-7.90	Peak	Horizontal
6	503.360	-67.42	-62.45	-13.00	-54.42	-4.97	Peak	Horizontal

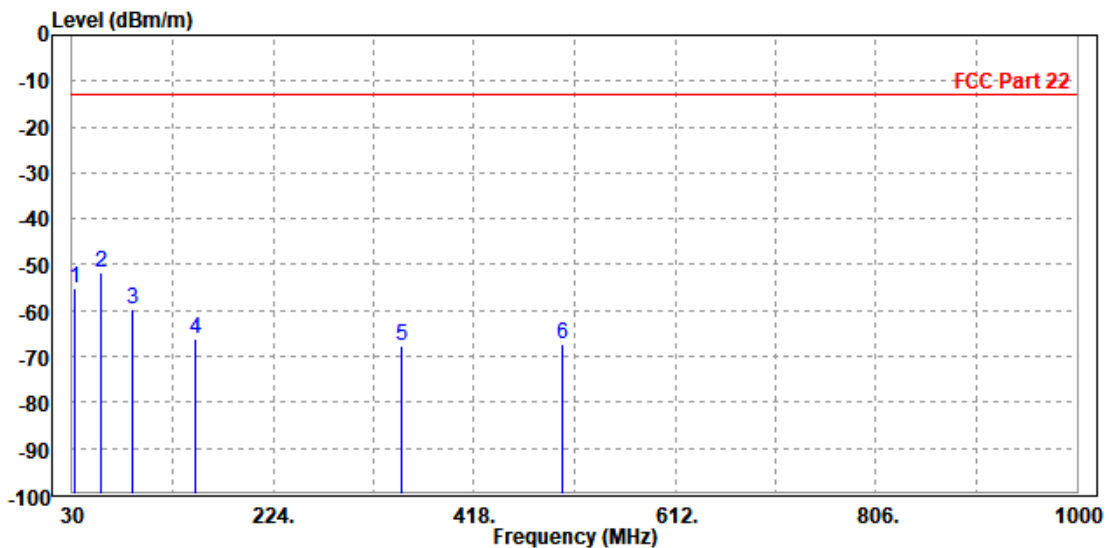



MODE	TX channel 4182	FREQUENCY RANGE	Below 1000MHz
ENVIRONMENTAL CONDITIONS	23deg. C, 70%RH	INPUT POWER	DC 14V
TESTED BY	Jace Hu		
ANTENNA POLARITY & TEST DISTANCE: VERTICAL AT 3 M			

	Freq	Level	Read Level	Limit Line	Over Limit	Factor	Remark	Pol/Phase	
	MHz	dBm/m	dBm	dBm/m	dB	dB/m			
1	PP	57.160	-49.19	-30.29	-13.00	-36.19	-18.90	Peak	Vertical
2		62.010	-57.29	-38.57	-13.00	-44.29	-18.72	Peak	Vertical
3		148.340	-64.04	-50.51	-13.00	-51.04	-13.53	Peak	Vertical
4		258.920	-64.64	-60.96	-13.00	-51.64	-3.68	Peak	Vertical
5		400.540	-65.44	-61.28	-13.00	-52.44	-4.16	Peak	Vertical
6		652.740	-64.23	-63.79	-13.00	-51.23	-0.44	Peak	Vertical

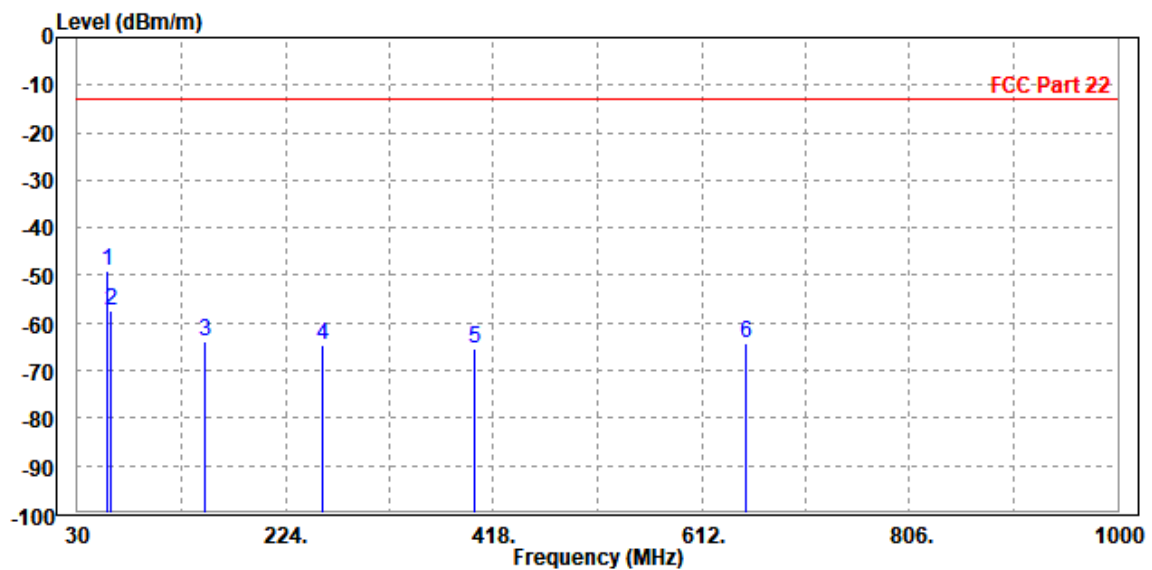



ABOVE 1GHz DATA

Note: For higher frequency, the emission is too low to be detected.

WCDMA Band V:

CH 4132:

MODE	TX channel 4132	FREQUENCY RANGE	Above 1000MHz
ENVIRONMENTAL CONDITIONS	23deg. C, 70%RH	INPUT POWER	DC 14V
TESTED BY	Jace Hu		
ANTENNA POLARITY & TEST DISTANCE: HORIZONTAL AT 3 M			

	Freq	Level	Read Level	Limit Line	Over Limit	Factor	Remark	Pol/Phase
	MHz	dBm/m	dBm	dBm/m	dB	dB/m		
1 PP	1648.000	-49.38	-53.04	-13.00	-36.38	3.66	Peak	Horizontal
2	2478.000	-51.08	-57.12	-13.00	-38.08	6.04	Peak	Horizontal

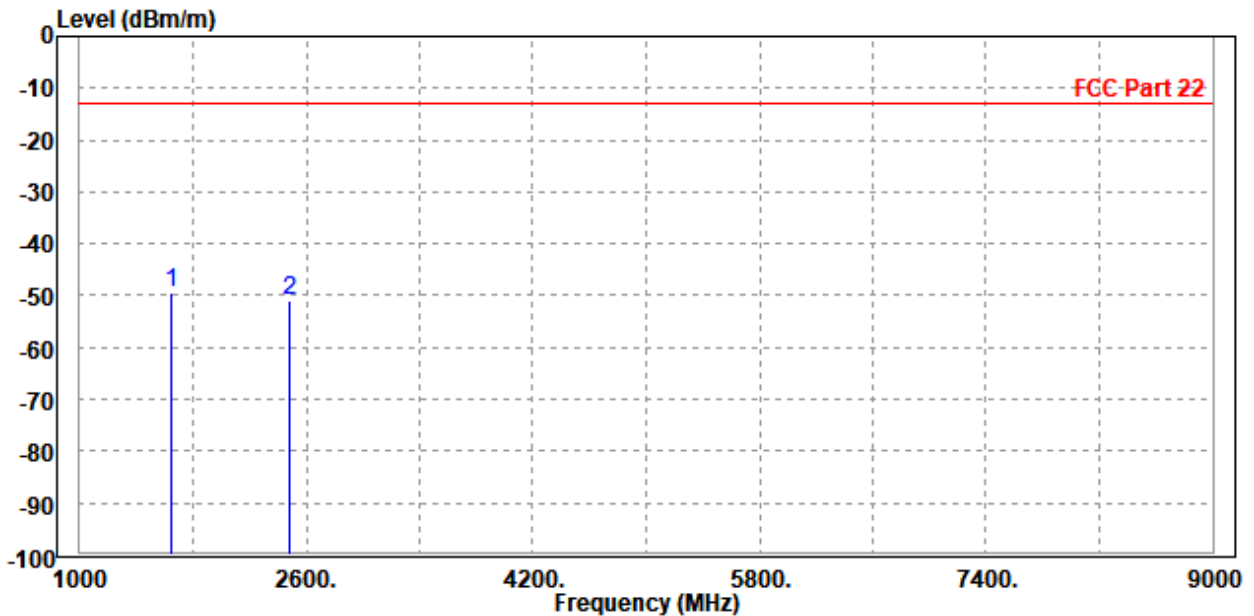



MODE	TX channel 4132	FREQUENCY RANGE	Above 1000MHz
ENVIRONMENTAL CONDITIONS	23deg. C, 70%RH	INPUT POWER	DC 14V
TESTED BY	Jace Hu		
ANTENNA POLARITY & TEST DISTANCE: VERTICAL AT 3 M			

	Freq	Level	Read Level	Limit Line	Over Limit	Factor	Remark	Pol/Phase
	MHz	dBm/m	dBm	dBm/m	dB	dB/m		
1	PP 1656.000	-50.31	-53.71	-13.00	-37.31	3.40	Peak	Vertical
2	2478.000	-51.46	-57.16	-13.00	-38.46	5.70	Peak	Vertical

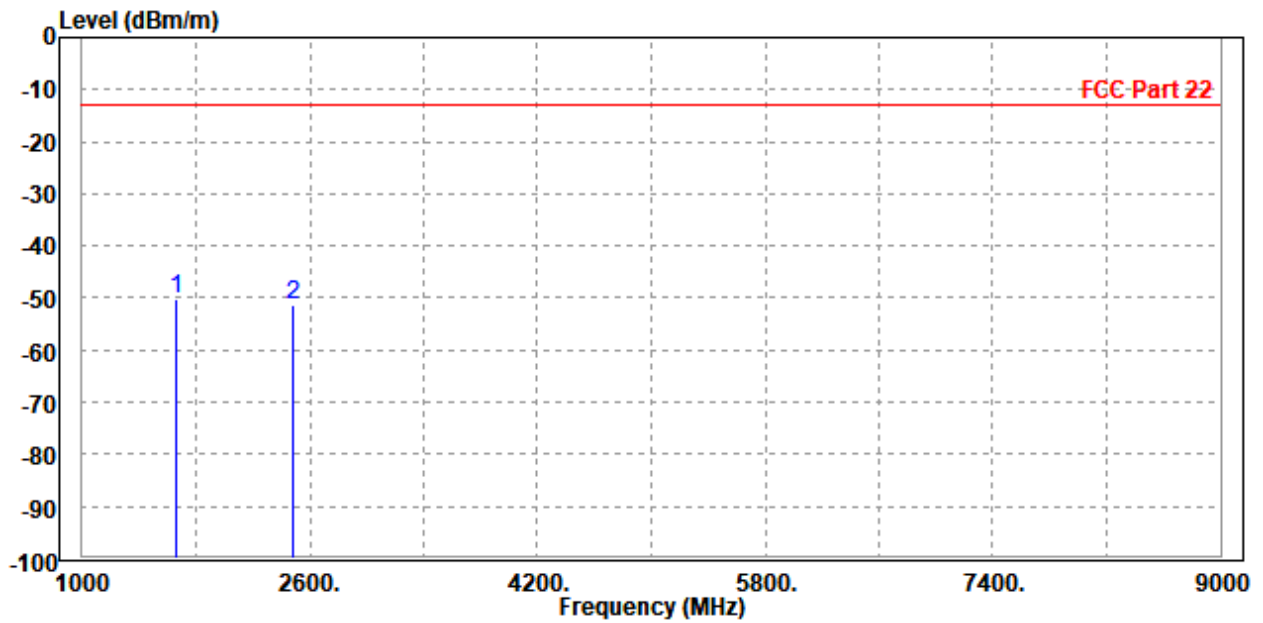



CH 4182:

MODE	TX channel 4182	FREQUENCY RANGE	Above 1000MHz
ENVIRONMENTAL CONDITIONS	23deg. C, 70%RH	INPUT POWER	DC 14V
TESTED BY	Jace Hu		
ANTENNA POLARITY & TEST DISTANCE: HORIZONTAL AT 3 M			

	Freq	Level	Read Level	Limit Line	Over Limit	Factor	Remark	Pol/Phase
	MHz	dBm/m	dBm	dBm/m	dB	dB/m		
1	PP 1672.000	-47.43	-51.16	-13.00	-34.43	3.73	Peak	Horizontal
2	2504.000	-50.32	-56.44	-13.00	-37.32	6.12	Peak	Horizontal

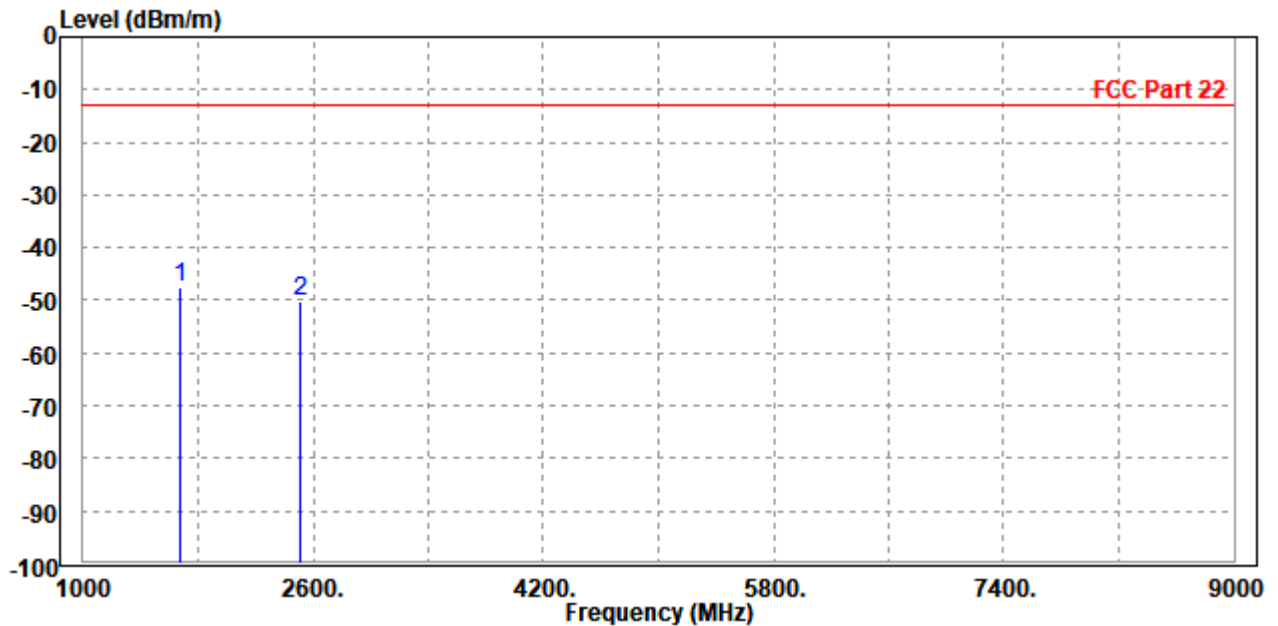



MODE	TX channel 4182	FREQUENCY RANGE	Above 1000MHz
ENVIRONMENTAL CONDITIONS	23deg. C, 70%RH	INPUT POWER	DC 14V
TESTED BY	Jace Hu		
ANTENNA POLARITY & TEST DISTANCE: VERTICAL AT 3 M			

	Freq	Level	Read Level	Limit Line	Over Limit	Factor	Remark	Pol/Phase
	MHz	dBm/m	dBm	dBm/m	dB	dB/m		
1	PP 1672.000	-49.85	-53.28	-13.00	-36.85	3.43	Peak	Vertical
2	2508.000	-51.66	-57.49	-13.00	-38.66	5.83	Peak	Vertical

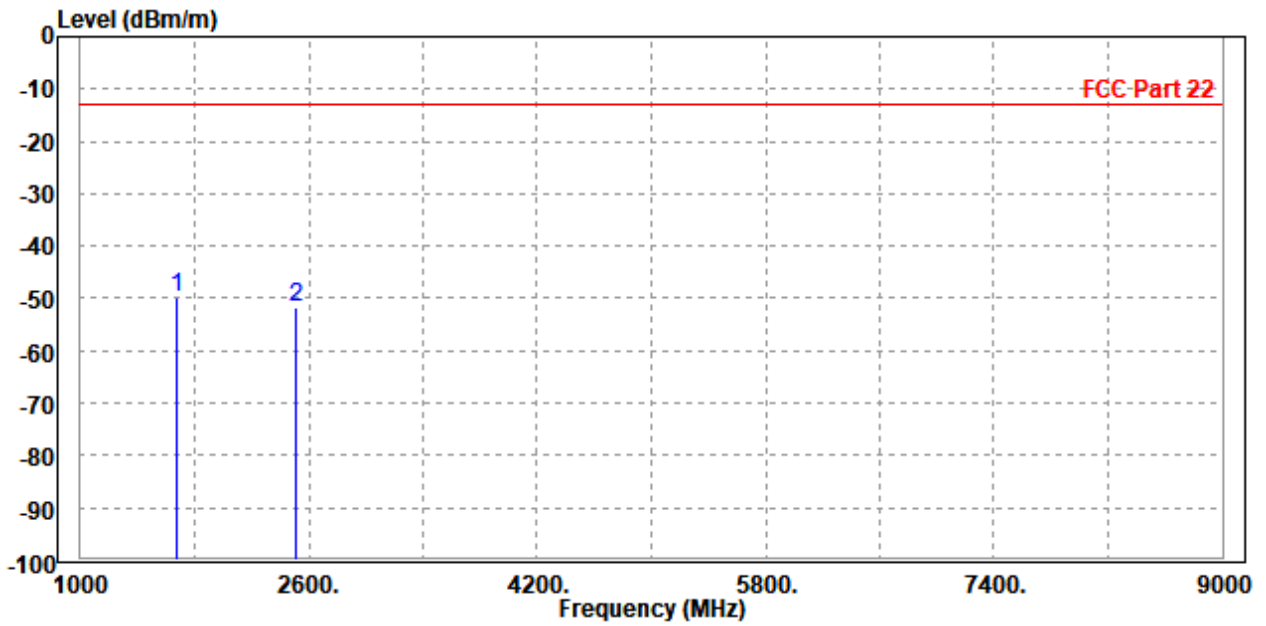



CH 4233:

MODE	TX channel 4233	FREQUENCY RANGE	Above 1000MHz
ENVIRONMENTAL CONDITIONS	23deg. C, 70%RH	INPUT POWER	DC 14V
TESTED BY	Jace Hu		
ANTENNA POLARITY & TEST DISTANCE: HORIZONTAL AT 3 M			

	Freq	Level	Read Level	Limit Line	Over Limit	Factor	Remark	Pol/Phase
	MHz	dBm/m	dBm	dBm/m	dB	dB/m		
1	1692.000	-52.27	-56.07	-13.00	-39.27	3.80	Peak	Horizontal
2 PP	2536.000	-50.14	-56.39	-13.00	-37.14	6.25	Peak	Horizontal

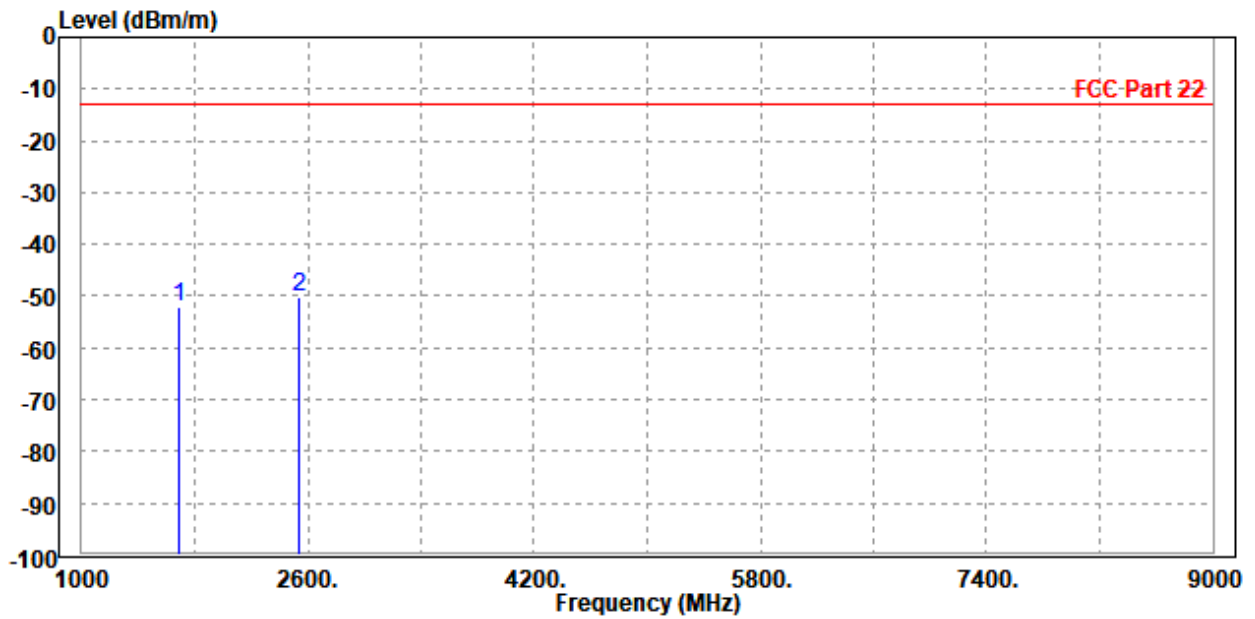



MODE	TX channel 4233	FREQUENCY RANGE	Above 1000MHz
ENVIRONMENTAL CONDITIONS	23deg. C, 70%RH	INPUT POWER	DC 14V
TESTED BY	Jace Hu		
ANTENNA POLARITY & TEST DISTANCE: VERTICAL AT 3 M			

	Freq	Level	Read Level	Limit Line	Over Limit	Factor	Remark	Pol/Phase
	MHz	dBm/m	dBm	dBm/m	dB	dB/m		
1	1688.000	-53.13	-56.59	-13.00	-40.13	3.46	Peak	Vertical
2 PP	2538.000	-50.66	-56.67	-13.00	-37.66	6.01	Peak	Vertical

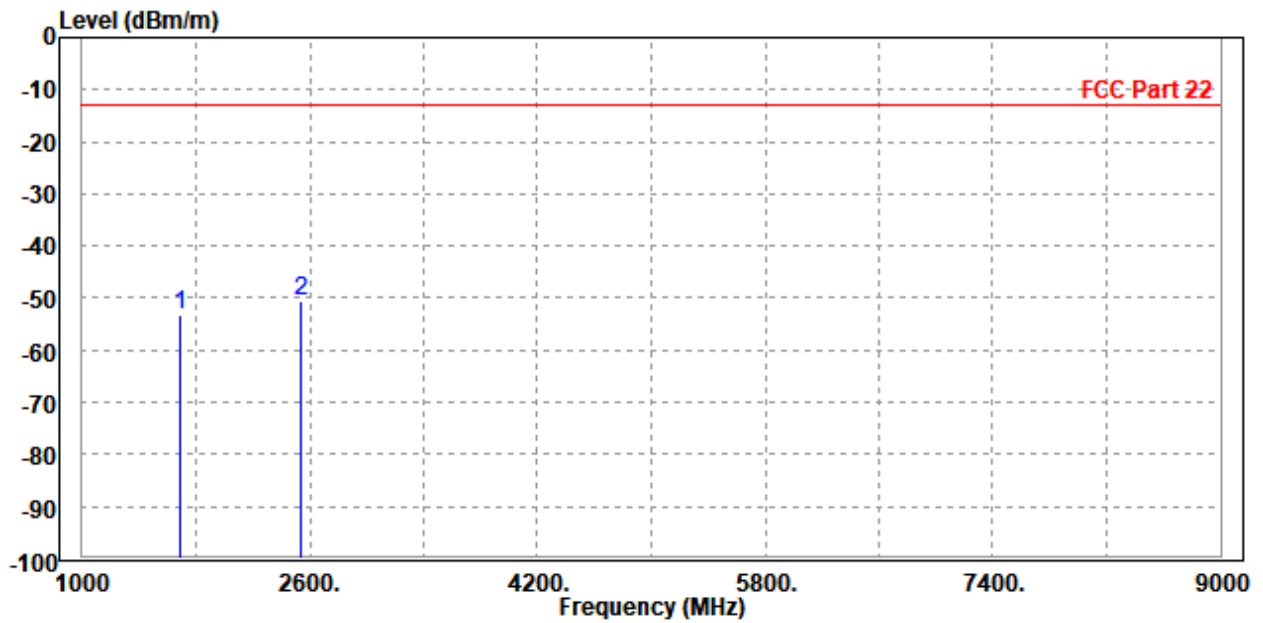



LTE Band 5

CHANNEL BANDWIDTH: 1.4MHz / QPSK

MODE	TX channel 20525	FREQUENCY RANGE	Above 1000MHz
ENVIRONMENTAL CONDITIONS	26deg. C, 56%RH	INPUT POWER	DC 14V
TESTED BY	Simon Yang		
ANTENNA POLARITY & TEST DISTANCE: HORIZONTAL AT 3 M			

	Freq	Level	Read Level	Limit Line	Over Limit	Factor	Remark	Pol/Phase
	MHz	dBm/m	dBm	dBm/m	dB	dB/m		
1	PP 1672.000	-48.68	-52.41	-13.00	-35.68	3.73	Peak	Horizontal
2	2504.000	-49.50	-55.62	-13.00	-36.50	6.12	Peak	Horizontal

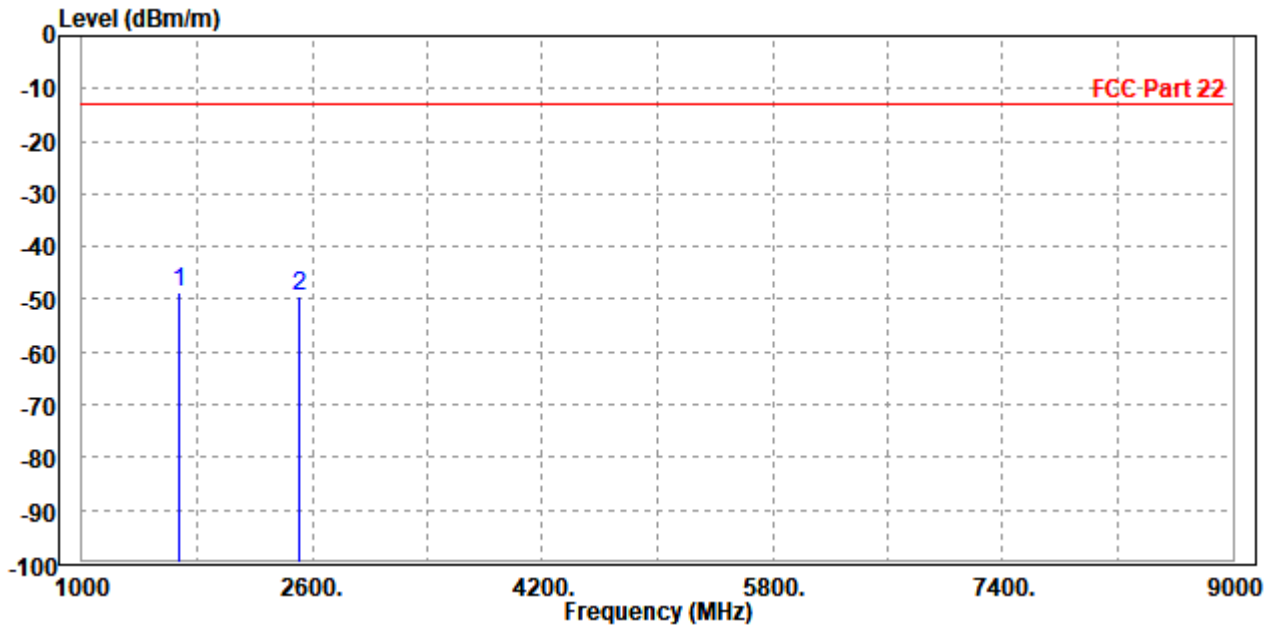



MODE	TX channel 20525	FREQUENCY RANGE	Above 1000MHz
ENVIRONMENTAL CONDITIONS	26deg. C, 56%RH	INPUT POWER	DC 14V
TESTED BY	Simon Yang		
ANTENNA POLARITY & TEST DISTANCE: VERTICAL AT 3 M			

	Freq	Level	Read Level	Limit Line	Over Limit	Factor	Remark	Pol/Phase
	MHz	dBm/m	dBm	dBm/m	dB	dB/m		
1 PP	1672.000	-50.03	-53.46	-13.00	-37.03	3.43	Peak	Vertical
2	2508.000	-50.66	-56.49	-13.00	-37.66	5.83	Peak	Vertical

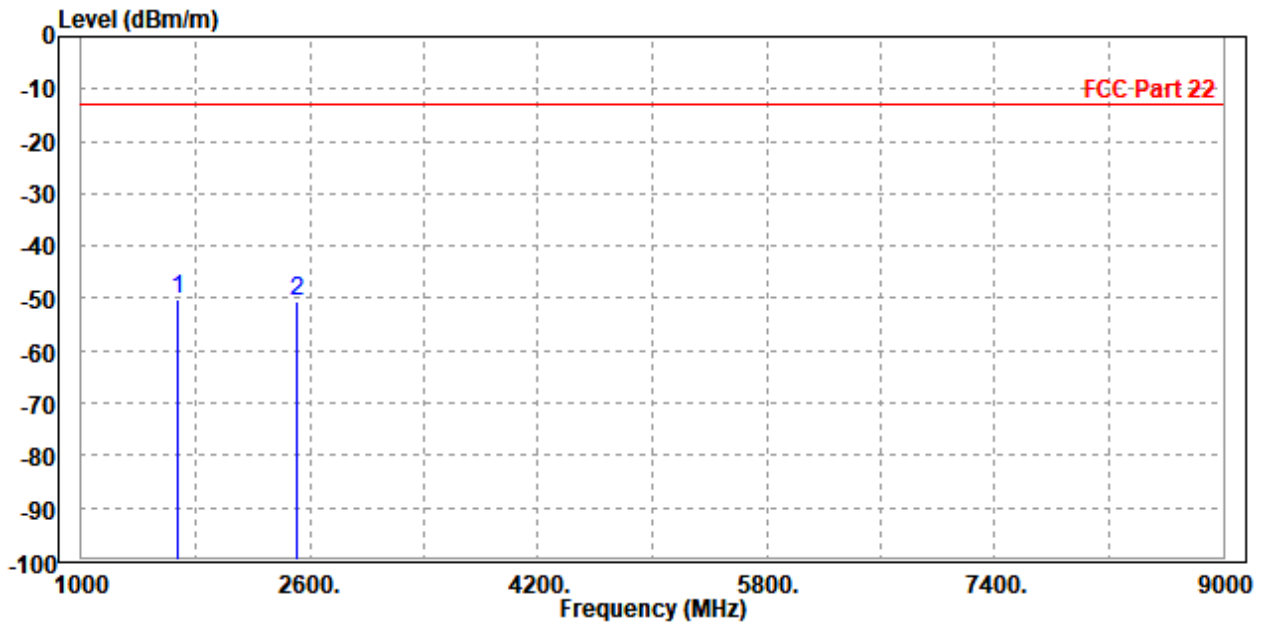



CHANNEL BANDWIDTH: 3MHz / QPSK

MODE	TX channel 20525	FREQUENCY RANGE	Above 1000MHz
ENVIRONMENTAL CONDITIONS	26deg. C, 56%RH	INPUT POWER	DC 14V
TESTED BY	Simon Yang		
ANTENNA POLARITY & TEST DISTANCE: HORIZONTAL AT 3 M			

	Freq	Level	Read Level	Limit Line	Over Limit	Factor	Remark	Pol/Phase
	MHz	dBm/m	dBm	dBm/m	dB	dB/m		
1	PP 1672.000	-48.78	-52.51	-13.00	-35.78	3.73	Peak	Horizontal
2	2504.000	-49.92	-56.04	-13.00	-36.92	6.12	Peak	Horizontal

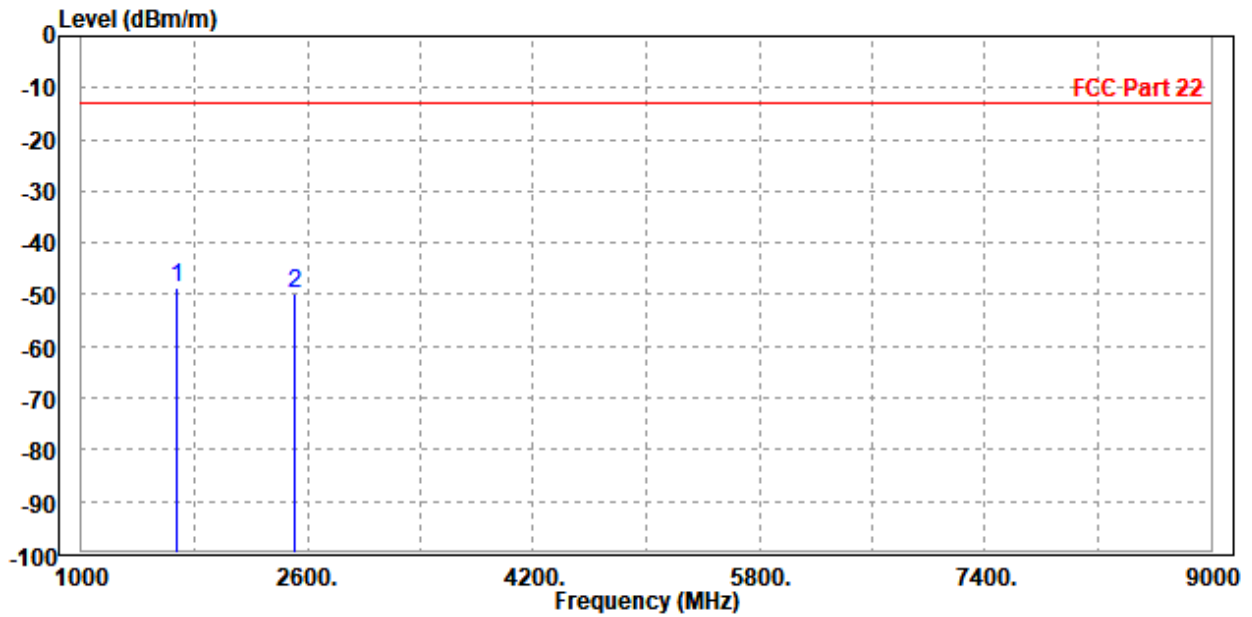



MODE	TX channel 20525	FREQUENCY RANGE	Above 1000MHz
ENVIRONMENTAL CONDITIONS	26deg. C, 56%RH	INPUT POWER	DC 14V
TESTED BY	Simon Yang		
ANTENNA POLARITY & TEST DISTANCE: VERTICAL AT 3 M			

	Freq	Level	Read Level	Limit Line	Over Limit	Factor	Remark	Pol/Phase
	MHz	dBm/m	dBm	dBm/m	dB	dB/m		
1	PP 1672.000	-49.75	-53.18	-13.00	-36.75	3.43	Peak	Vertical
2	2504.000	-51.17	-56.97	-13.00	-38.17	5.80	Peak	Vertical

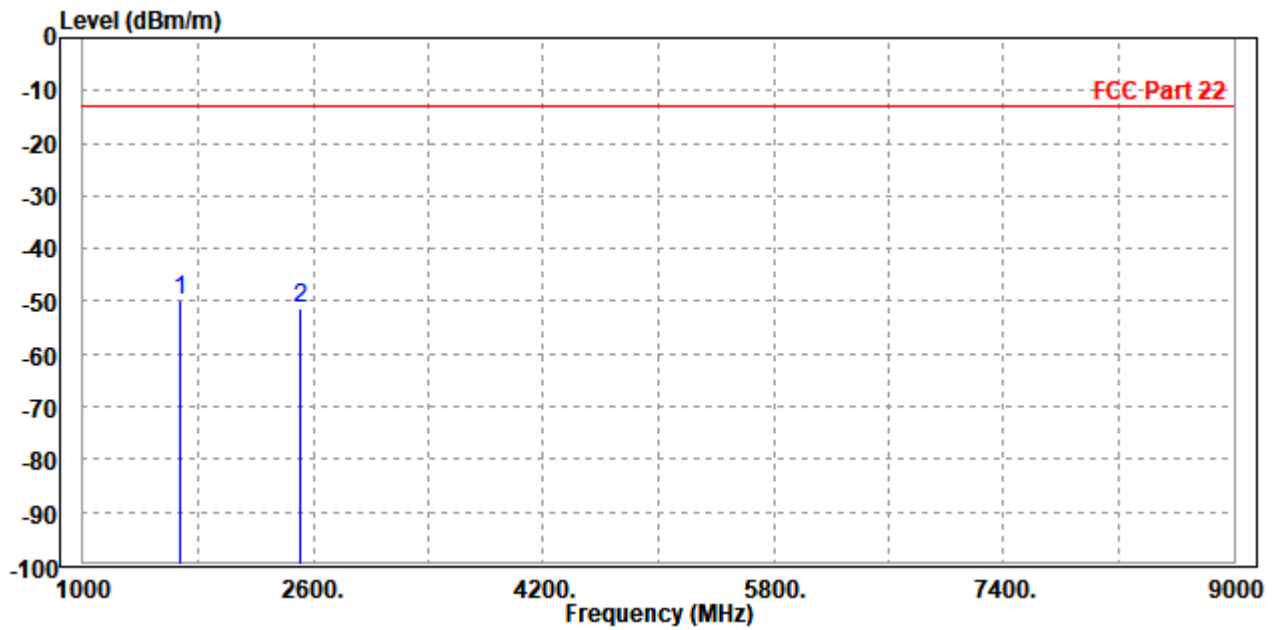



CHANNEL BANDWIDTH: 5MHz / QPSK

CH 20425

MODE	TX channel 20425	FREQUENCY RANGE	Above 1000MHz
ENVIRONMENTAL CONDITIONS	23deg. C, 70%RH	INPUT POWER	DC 14V
TESTED BY	Simon Yang		
ANTENNA POLARITY & TEST DISTANCE: HORIZONTAL AT 3 M			

	Freq	Level	Read Level	Limit Line	Over Limit	Factor	Remark	Pol/Phase
	MHz	dBm/m	dBm	dBm/m	dB	dB/m		
1	PP 1648.000	-49.41	-53.07	-13.00	-36.41	3.66	Peak	Horizontal
2	2478.000	-50.40	-56.44	-13.00	-37.40	6.04	Peak	Horizontal

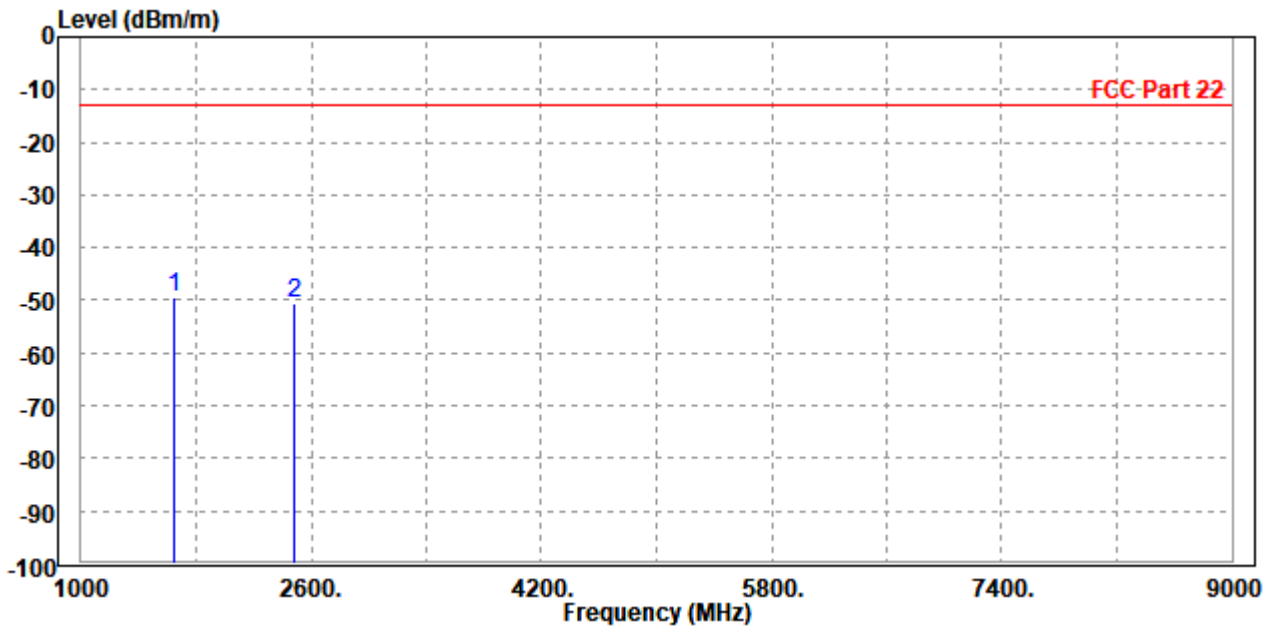



MODE	TX channel 20425	FREQUENCY RANGE	Above 1000MHz
ENVIRONMENTAL CONDITIONS	23deg. C, 70%RH	INPUT POWER	DC 14V
TESTED BY	Simon Yang		
ANTENNA POLARITY & TEST DISTANCE: VERTICAL AT 3 M			

	Read	Limit	Over				
Freq	Level	Level	Line	Limit	Factor	Remark	Pol/Phase
MHz	dBm/m	dBm	dBm/m	dB	dB/m		
1 PP 1648.000	-50.13	-53.52	-13.00	-37.13	3.39	Peak	Vertical
2 2480.000	-50.99	-56.70	-13.00	-37.99	5.71	Peak	Vertical

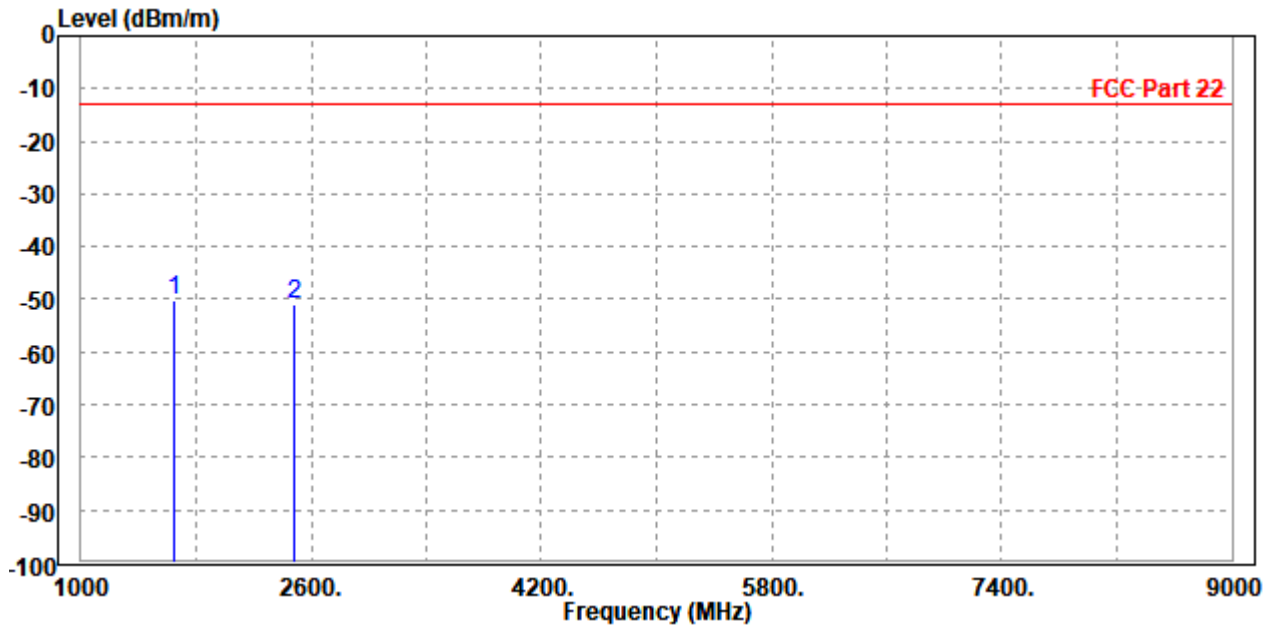



CH 20525

MODE	TX channel 20525	FREQUENCY RANGE	Above 1000MHz
ENVIRONMENTAL CONDITIONS	23deg. C, 70%RH	INPUT POWER	DC 14V
TESTED BY	Simon Yang		
ANTENNA POLARITY & TEST DISTANCE: HORIZONTAL AT 3 M			

	Freq	Level	Read Level	Limit Line	Over Limit	Factor	Remark	Pol/Phase
	MHz	dBm/m	dBm	dBm/m	dB	dB/m		
1	PP 1672.000	-48.45	-52.18	-13.00	-35.45	3.73	Peak	Horizontal
2	2504.000	-50.33	-56.45	-13.00	-37.33	6.12	Peak	Horizontal

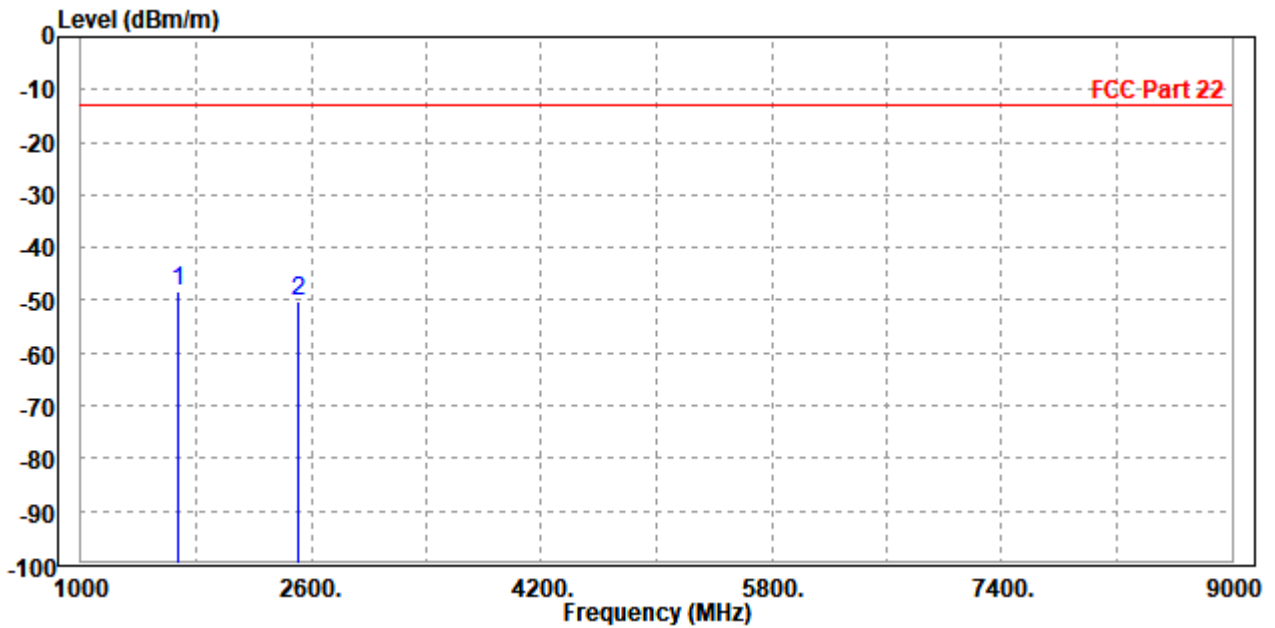



MODE	TX channel 20525	FREQUENCY RANGE	Above 1000MHz
ENVIRONMENTAL CONDITIONS	23deg. C, 70%RH	INPUT POWER	DC 14V
TESTED BY	Simon Yang		
ANTENNA POLARITY & TEST DISTANCE: VERTICAL AT 3 M			

	Freq	Level	Read Level	Limit Line	Over Limit	Factor	Remark	Pol/Phase
	MHz	dBm/m	dBm	dBm/m	dB	dB/m		
1 PP	1672.000	-46.36	-49.79	-13.00	-33.36	3.43	Peak	Vertical
2	2504.000	-51.04	-56.84	-13.00	-38.04	5.80	Peak	Vertical

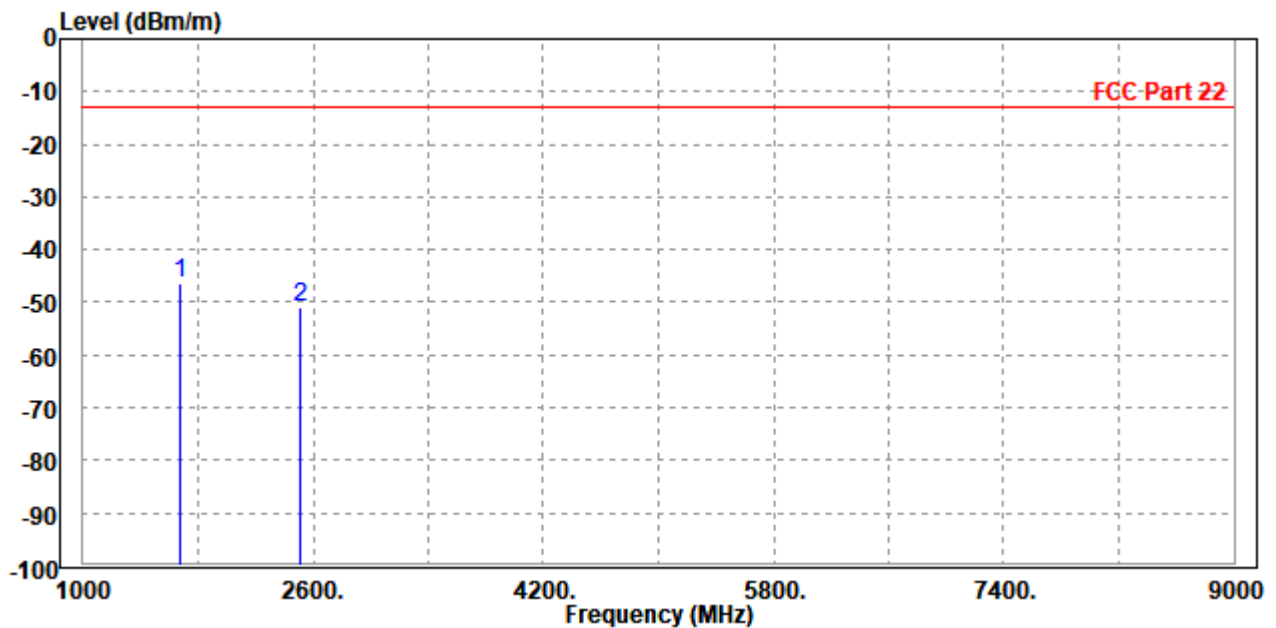



CH 20625

MODE	TX channel 20625	FREQUENCY RANGE	Above 1000MHz
ENVIRONMENTAL CONDITIONS	23deg. C, 70%RH	INPUT POWER	DC 14V
TESTED BY	Simon Yang		
ANTENNA POLARITY & TEST DISTANCE: HORIZONTAL AT 3 M			

	Freq	Level	Read Level	Limit Line	Over Limit	Factor	Remark	Pol/Phase
	MHz	dBm/m	dBm	dBm/m	dB	dB/m		
1	1692.000	-51.03	-54.83	-13.00	-38.03	3.80	Peak	Horizontal
2 PP	2536.000	-49.71	-55.96	-13.00	-36.71	6.25	Peak	Horizontal

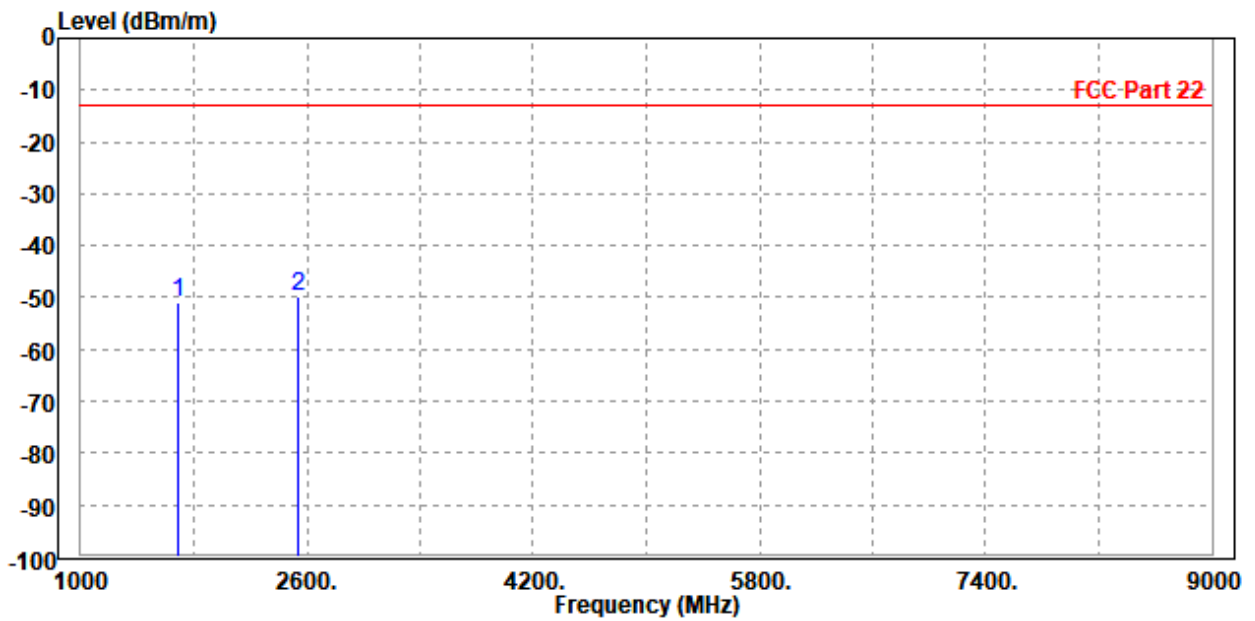



MODE	TX channel 20625	FREQUENCY RANGE	Above 1000MHz
ENVIRONMENTAL CONDITIONS	23deg. C, 70%RH	INPUT POWER	DC 14V
TESTED BY	Simon Yang		
ANTENNA POLARITY & TEST DISTANCE: VERTICAL AT 3 M			

	Freq	Level	Read Level	Limit Line	Over Limit	Factor	Remark	Pol/Phase
	MHz	dBm/m	dBm	dBm/m	dB	dB/m		
1	1688.000	-50.17	-53.63	-13.00	-37.17	3.46	Peak	Vertical
2	PP 2538.000	-50.10	-56.11	-13.00	-37.10	6.01	Peak	Vertical

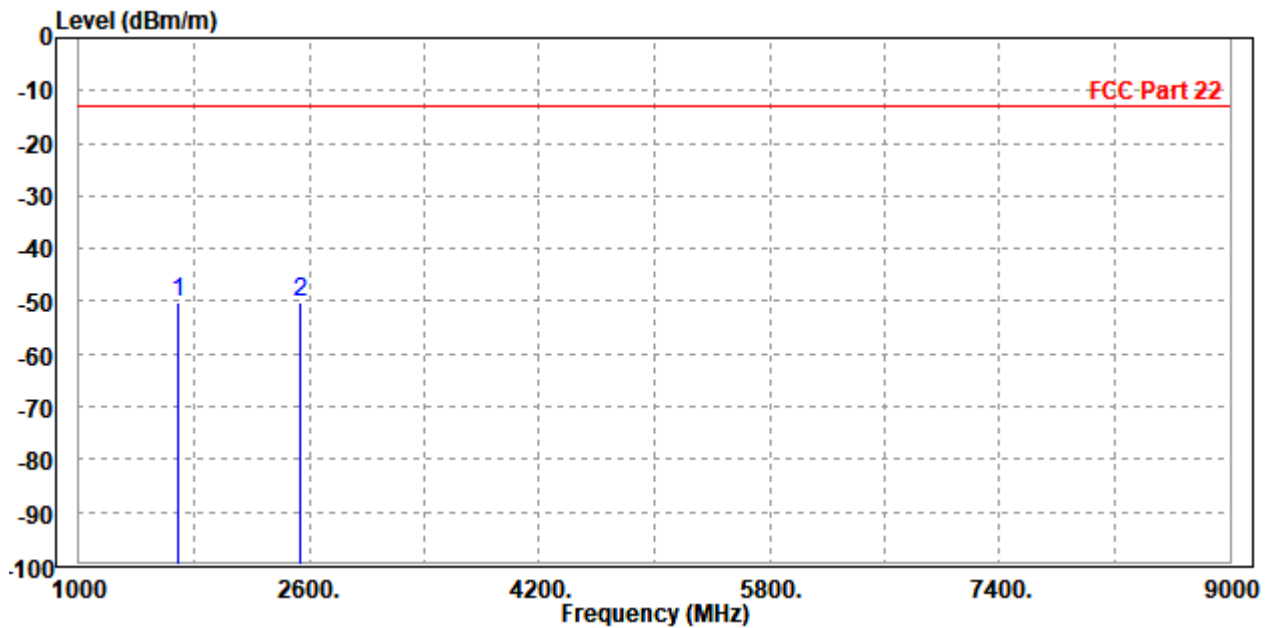



CHANNEL BANDWIDTH: 10MHz / QPSK

MODE	TX channel 20525	FREQUENCY RANGE	Above 1000MHz
ENVIRONMENTAL CONDITIONS	26deg. C, 56%RH	INPUT POWER	DC 14V
TESTED BY	Simon Yang		
ANTENNA POLARITY & TEST DISTANCE: HORIZONTAL AT 3 M			

	Freq	Level	Read Level	Limit Line	Over Limit	Factor	Remark	Pol/Phase
	MHz	dBm/m	dBm	dBm/m	dB	dB/m		
1	1672.000	-53.62	-57.35	-13.00	-40.62	3.73	Peak	Horizontal
2 PP	2508.000	-50.01	-56.14	-13.00	-37.01	6.13	Peak	Horizontal

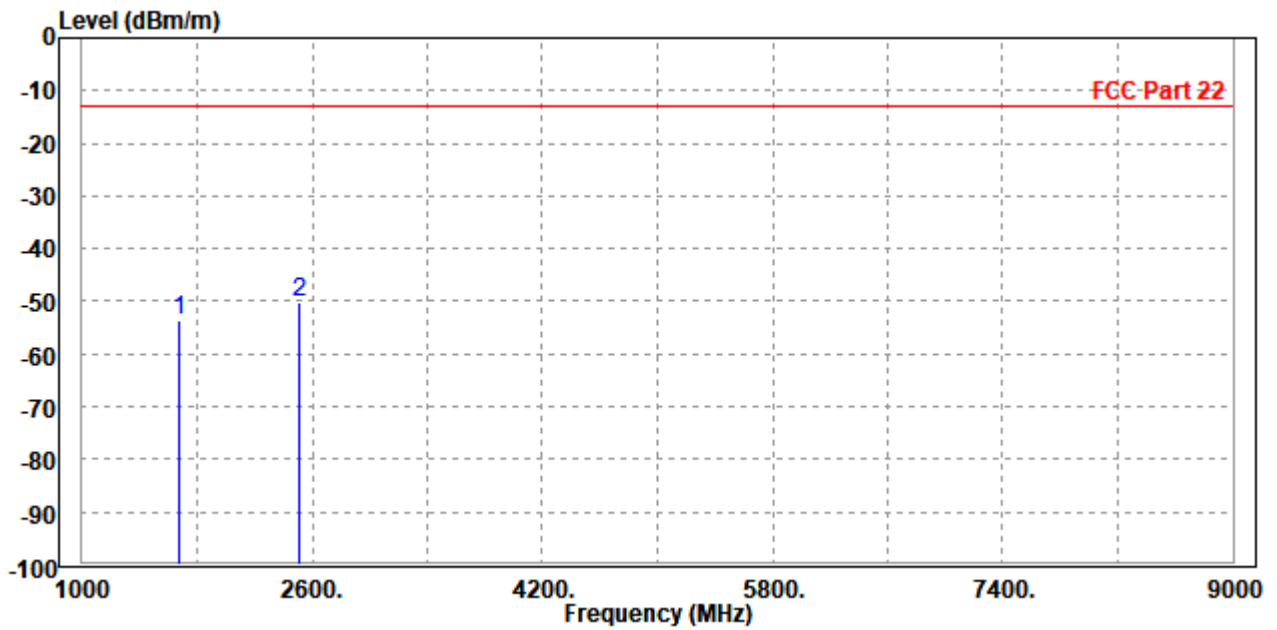



MODE	TX channel 20525	FREQUENCY RANGE	Above 1000MHz
ENVIRONMENTAL CONDITIONS	26deg. C, 56%RH	INPUT POWER	DC 14V
TESTED BY	Simon Yang		
ANTENNA POLARITY & TEST DISTANCE: VERTICAL AT 3 M			

	Freq	Level	Read Level	Limit Line	Over Limit	Factor	Remark	Pol/Phase
	MHz	dBm/m	dBm	dBm/m	dB	dB/m		
1	1672.000	-56.11	-59.54	-13.00	-43.11	3.43	Peak	Vertical
2	PP 2504.000	-48.99	-54.79	-13.00	-35.99	5.80	Peak	Vertical

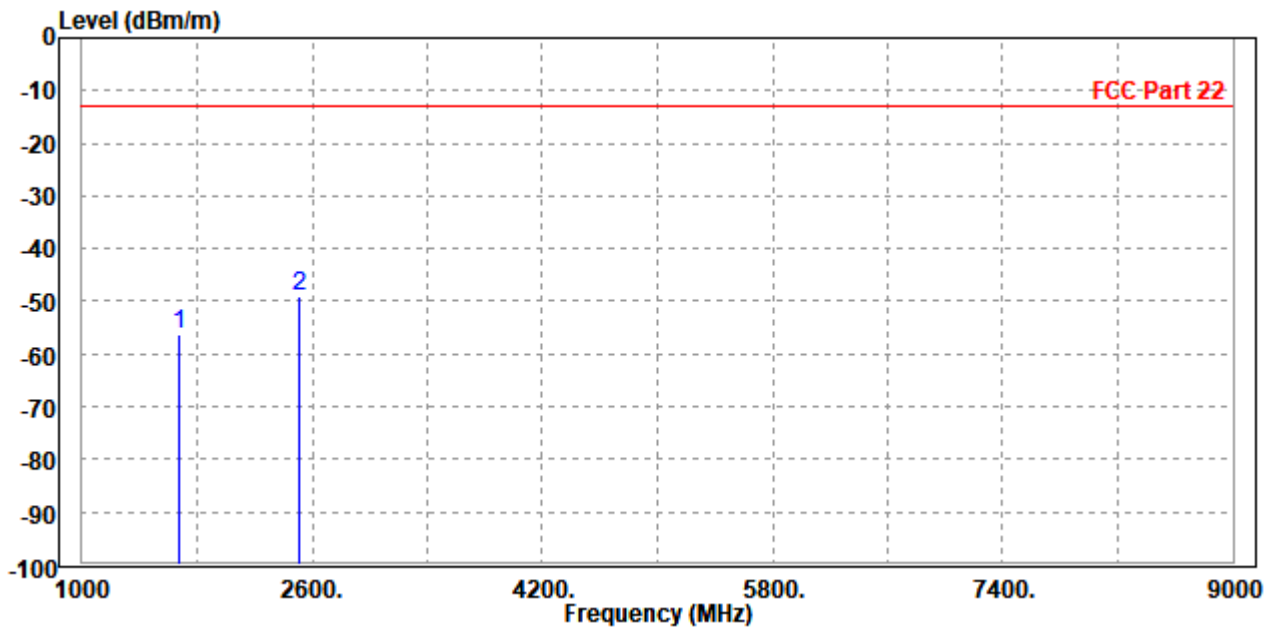



CA_5B:

CHANNEL BANDWIDTH: 10MHz+10MHz / QPSK

CH 20450/20549

MODE	TX channel 20450/20549	FREQUENCY RANGE	Above 1000MHz
ENVIRONMENTAL CONDITIONS	23deg. C, 70%RH	INPUT POWER	DC 14V
TESTED BY	Jace Hu		
ANTENNA POLARITY & TEST DISTANCE: HORIZONTAL AT 3 M			

	Freq	Level	Read Level	Limit Line	Over Limit	Factor	Remark	Pol/Phase
	MHz	dBm/m	dBm	dBm/m	dB	dB/m		
1	1658.000	-55.05	-58.74	-13.00	-42.05	3.69	Peak	Horizontal
2	1677.800	-56.34	-60.09	-13.00	-43.34	3.75	Peak	Horizontal
3	2487.000	-53.07	-59.13	-13.00	-40.07	6.06	Peak	Horizontal
4 PP	2520.000	-52.67	-58.86	-13.00	-39.67	6.19	Peak	Horizontal

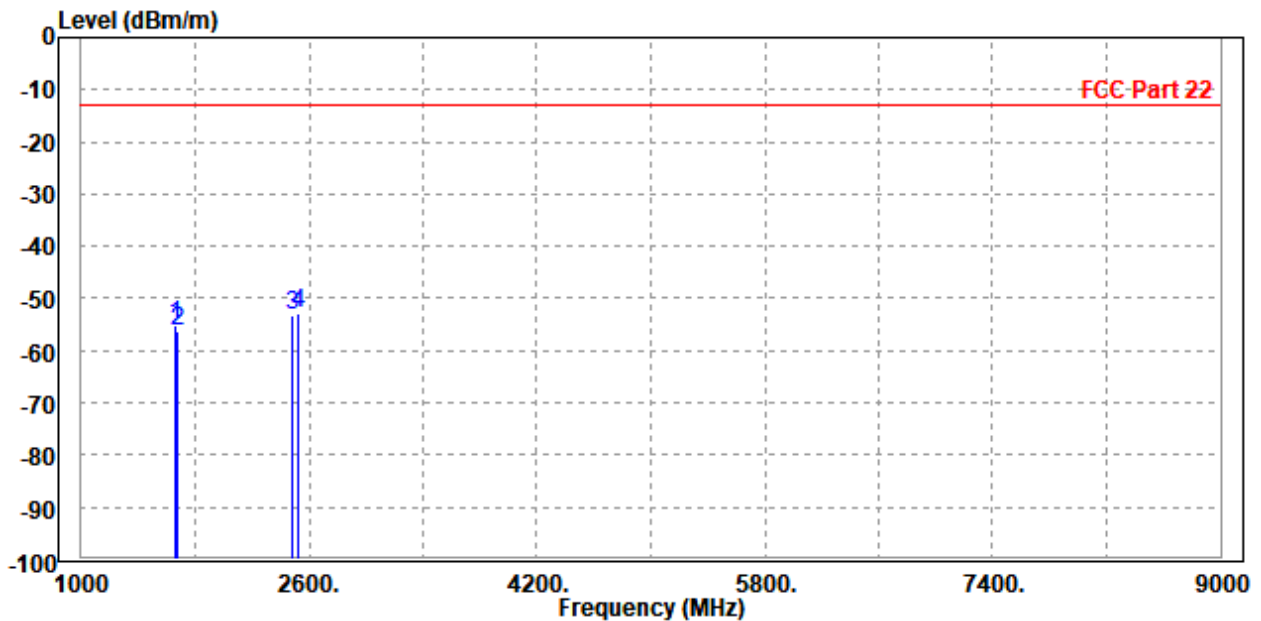



MODE	TX channel 20450/20549	FREQUENCY RANGE	Above 1000MHz
ENVIRONMENTAL CONDITIONS	23deg. C, 70%RH	INPUT POWER	DC 14V
TESTED BY	Jace Hu		
ANTENNA POLARITY & TEST DISTANCE: VERTICAL AT 3 M			

	Freq	Level	Read Level	Limit Line	Over Limit	Factor	Remark	Pol/Phase
	MHz	dBm/m	dBm	dBm/m	dB	dB/m		
1	1656.000	-55.70	-59.10	-13.00	-42.70	3.40	Peak	Vertical
2	1677.800	-55.37	-58.81	-13.00	-42.37	3.44	Peak	Vertical
3	2487.000	-54.10	-59.83	-13.00	-41.10	5.73	Peak	Vertical
4 PP	2516.700	-53.96	-59.84	-13.00	-40.96	5.88	Peak	Vertical

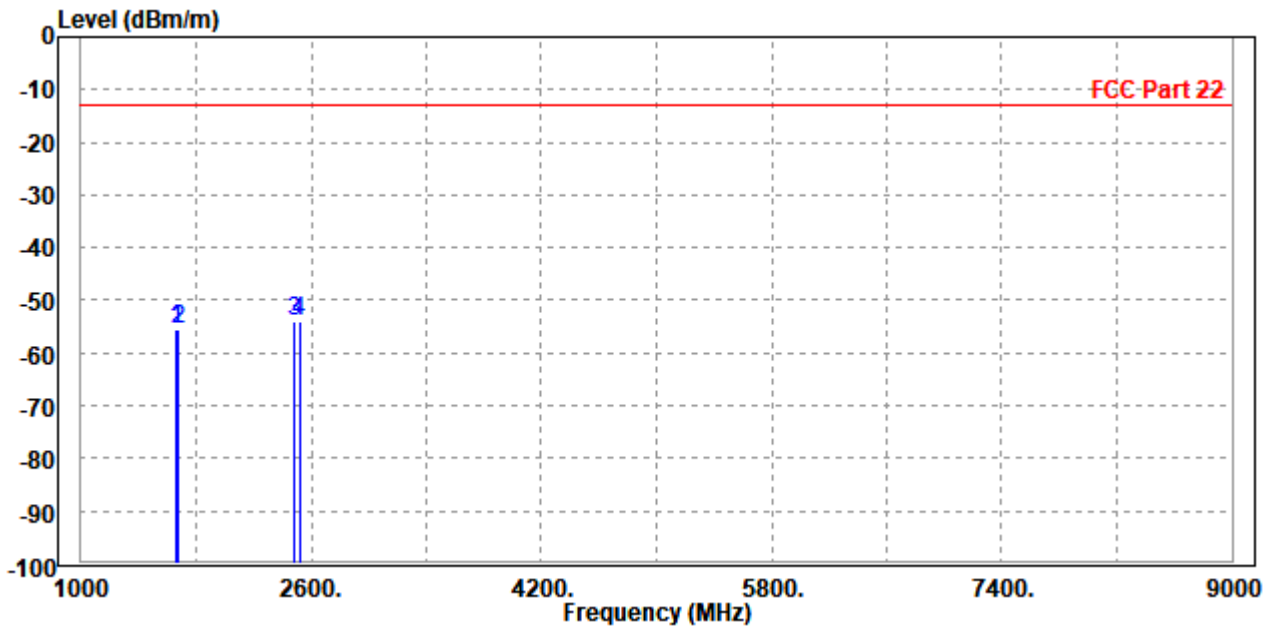



CH 20476/20575

MODE	TX channel 20476/20575	FREQUENCY RANGE	Above 1000MHz
ENVIRONMENTAL CONDITIONS	23deg. C, 70%RH	INPUT POWER	DC 14V
TESTED BY	Jace Hu		
ANTENNA POLARITY & TEST DISTANCE: HORIZONTAL AT 3 M			

	Freq	Level	Read Level	Limit Line	Over Limit	Factor	Remark	Pol/Phase
	MHz	dBm/m	dBm	dBm/m	dB	dB/m		
1	1664.000	-53.97	-57.68	-13.00	-40.97	3.71	Peak	Horizontal
2	1683.000	-54.84	-58.61	-13.00	-41.84	3.77	Peak	Horizontal
3	2494.500	-51.39	-57.48	-13.00	-38.39	6.09	Peak	Horizontal
4 PP	2524.500	-49.73	-55.94	-13.00	-36.73	6.21	Peak	Horizontal

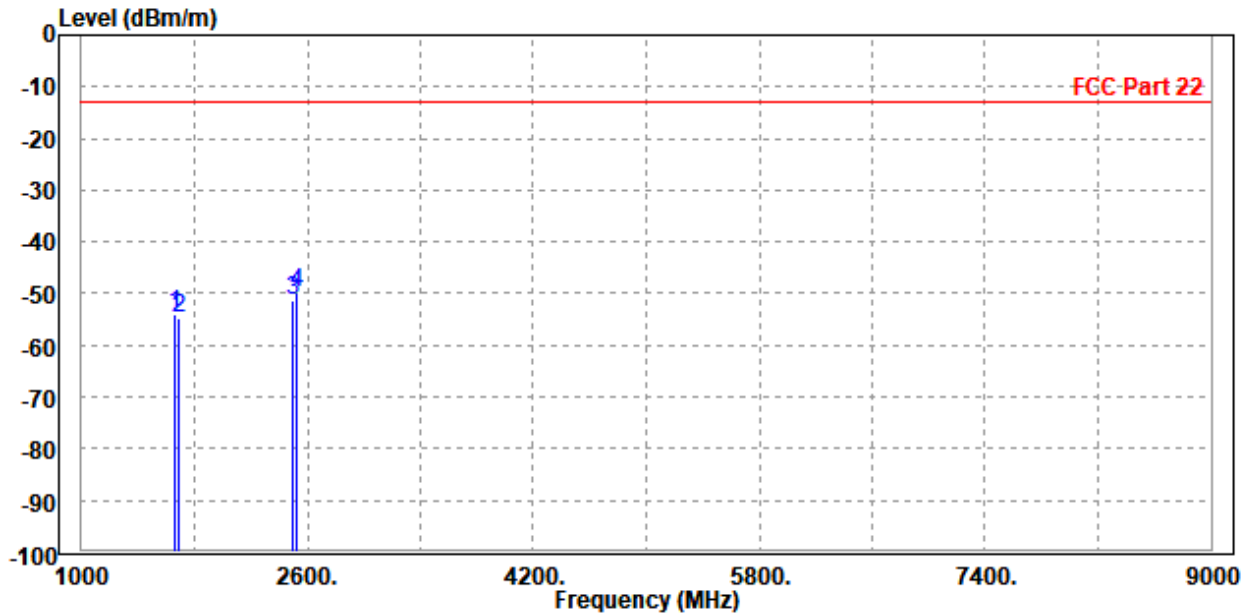



**BUREAU
VERITAS**

Test Report No.: W7L-240430W002RF02

MODE	TX channel 20476/20575	FREQUENCY RANGE	Above 1000MHz
ENVIRONMENTAL CONDITIONS	23deg. C, 70%RH	INPUT POWER	DC 14V
TESTED BY	Jace Hu		
ANTENNA POLARITY & TEST DISTANCE: VERTICAL AT 3 M			

	Freq	Level	Read Level	Limit Line	Over Limit	Factor	Remark	Pol/Phase
	MHz	dBm/m	dBm	dBm/m	dB	dB/m		
1	1663.000	-55.55	-58.96	-13.00	-42.55	3.41	Peak	Vertical
2	1683.000	-55.53	-58.98	-13.00	-42.53	3.45	Peak	Vertical
3	2494.500	-50.46	-56.22	-13.00	-37.46	5.76	Peak	Vertical
4 PP	2528.000	-50.16	-56.11	-13.00	-37.16	5.95	Peak	Vertical

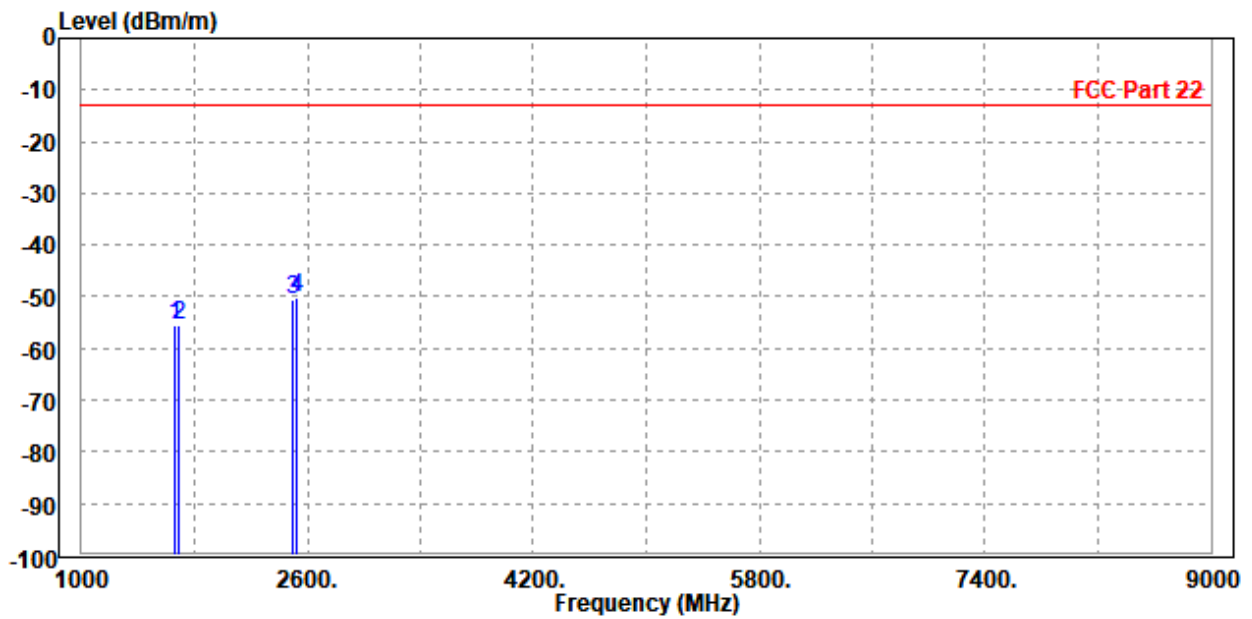



CH 20501/20600

MODE	TX channel 20501/20600	FREQUENCY RANGE	Above 1000MHz
ENVIRONMENTAL CONDITIONS	23deg. C, 70%RH	INPUT POWER	DC 14V
TESTED BY	Jace Hu		
ANTENNA POLARITY & TEST DISTANCE: HORIZONTAL AT 3 M			

	Freq	Level	Read Level	Limit Line	Over Limit	Factor	Remark	Pol/Phase
	MHz	dBm/m	dBm	dBm/m	dB	dB/m		
1	1672.000	-54.87	-58.60	-13.00	-41.87	3.73	Peak	Horizontal
2	1688.000	-55.39	-59.17	-13.00	-42.39	3.78	Peak	Horizontal
3	2502.300	-52.96	-59.07	-13.00	-39.96	6.11	Peak	Horizontal
4 PP	2532.000	-52.57	-58.81	-13.00	-39.57	6.24	Peak	Horizontal

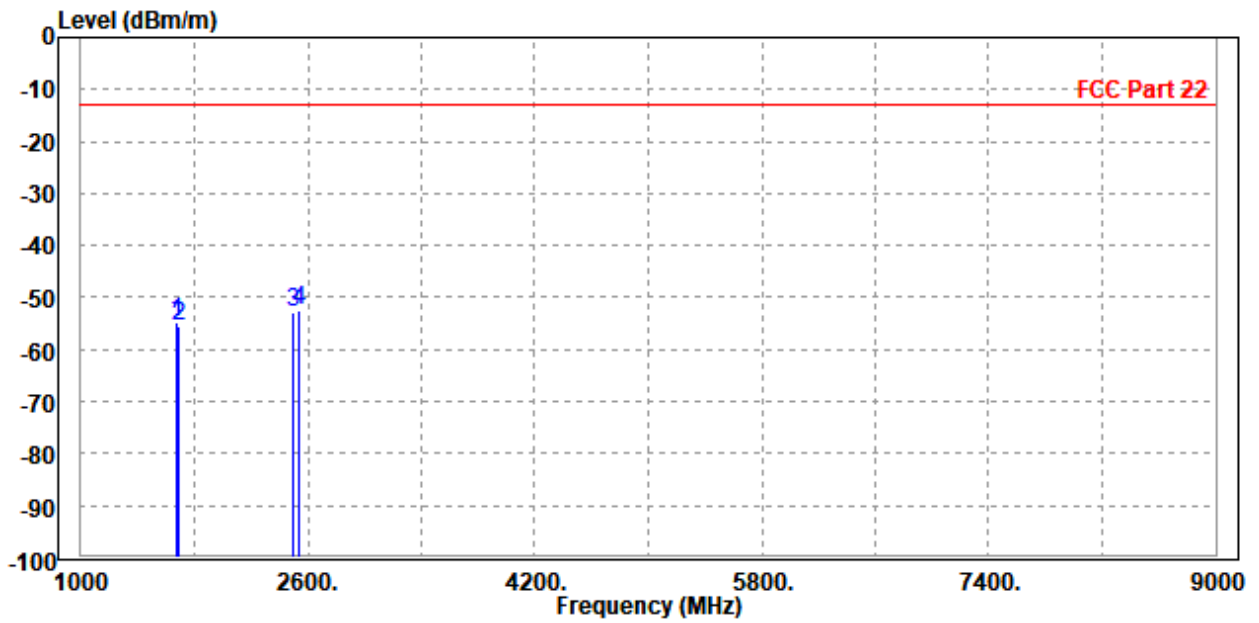



MODE	TX channel 20501/20600	FREQUENCY RANGE	Above 1000MHz
ENVIRONMENTAL CONDITIONS	23deg. C, 70%RH	INPUT POWER	DC 14V
TESTED BY	Jace Hu		
ANTENNA POLARITY & TEST DISTANCE: VERTICAL AT 3 M			

	Freq	Level	Read Level	Limit Line	Over Limit	Factor	Remark	Pol/Phase
	MHz	dBm/m	dBm	dBm/m	dB	dB/m		
1	1668.200	-55.07	-58.49	-13.00	-42.07	3.42	Peak	Vertical
2	1688.000	-55.68	-59.14	-13.00	-42.68	3.46	Peak	Vertical
3 PP	2502.300	-52.67	-58.46	-13.00	-39.67	5.79	Peak	Vertical
4	2536.000	-53.61	-59.61	-13.00	-40.61	6.00	Peak	Vertical

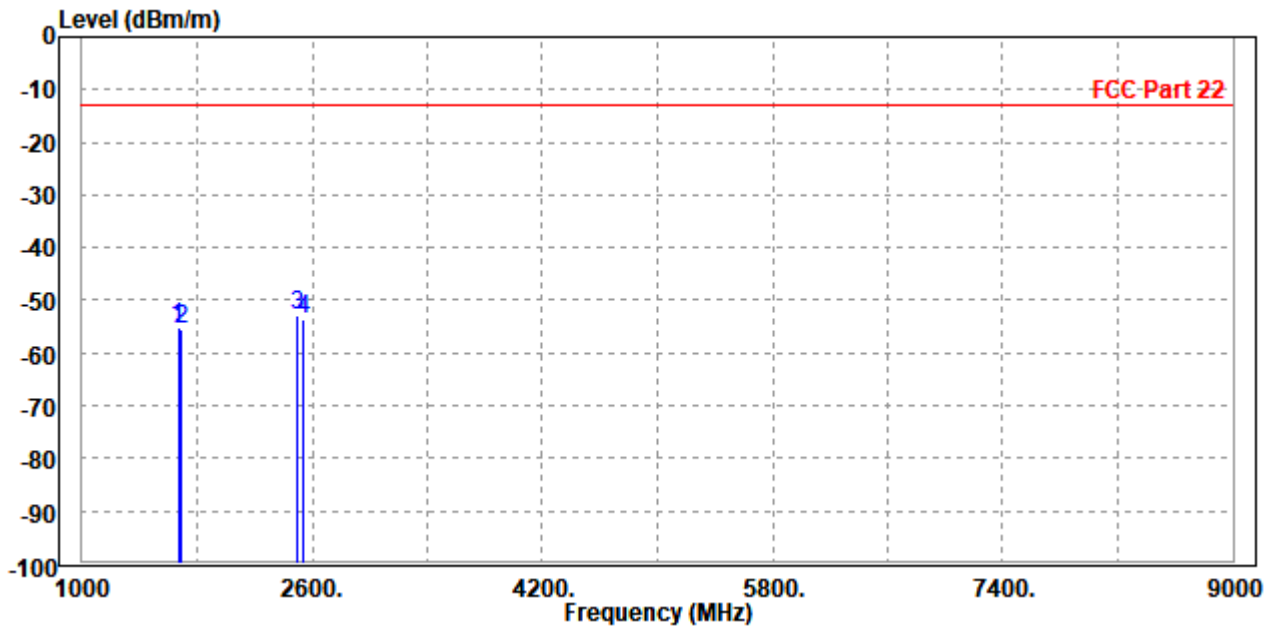



**BUREAU
VERITAS**

Test Report No.: W7L-240430W002RF02

LTE 5A-66A

CHANNEL BANDWIDTH: (10+20) MHz / QPSK

MODE	TX channel PCC 20525	FREQUENCY RANGE	Above 1000MHz
	TX channel SCC 132322		
ENVIRONMENTAL CONDITIONS	23deg. C, 70%RH	INPUT POWER	DC 14V
TESTED BY	Jace Hu		
ANTENNA POLARITY & TEST DISTANCE: HORIZONTAL AT 3 M			

	Freq	Level	Read Level	Limit Line	Over Limit	Factor	Remark	Pol/Phase
	MHz	dBm/m	dBm	dBm/m	dB	dB/m		
1	1673.000	-55.82	-59.56	-13.00	-42.82	3.74	Peak	Horizontal
2	2509.500	-54.89	-61.03	-13.00	-41.89	6.14	Peak	Horizontal
3	3510.000	-51.17	-59.72	-13.00	-38.17	8.55	Peak	Horizontal
4 PP	5267.000	-49.37	-60.83	-13.00	-36.37	11.46	Peak	Horizontal

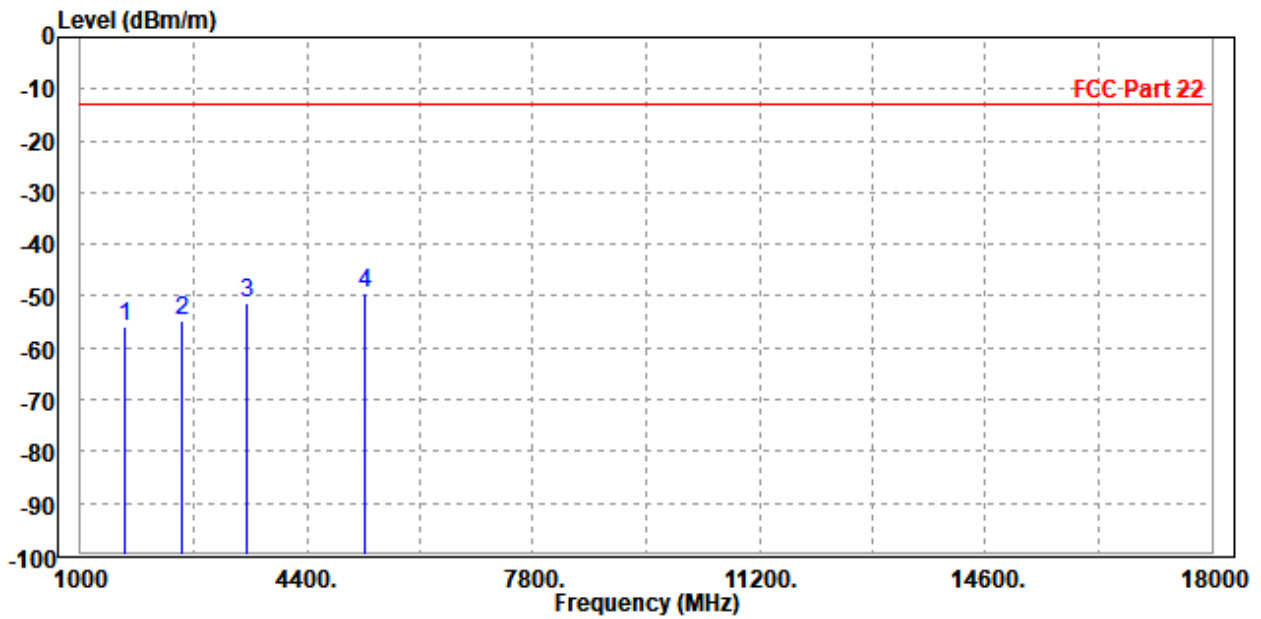



MODE	TX channel PCC 20525	FREQUENCY RANGE	Above 1000MHz
	TX channel SCC 132322		
ENVIRONMENTAL CONDITIONS	23deg. C, 70%RH	INPUT POWER	DC 14V
TESTED BY	Jace Hu		
ANTENNA POLARITY & TEST DISTANCE: VERTICAL AT 3 M			

	Freq	Level	Read Level	Limit Line	Over Limit	Factor	Remark	Pol/Phase
	MHz	dBm/m	dBm	dBm/m	dB	dB/m		
1	1680.000	-54.88	-58.32	-13.00	-41.88	3.44	Peak	Vertical
2	2509.500	-53.96	-59.80	-13.00	-40.96	5.84	Peak	Vertical
3	3510.000	-51.33	-59.97	-13.00	-38.33	8.64	Peak	Vertical
4 PP	5265.000	-47.60	-59.48	-13.00	-34.60	11.88	Peak	Vertical

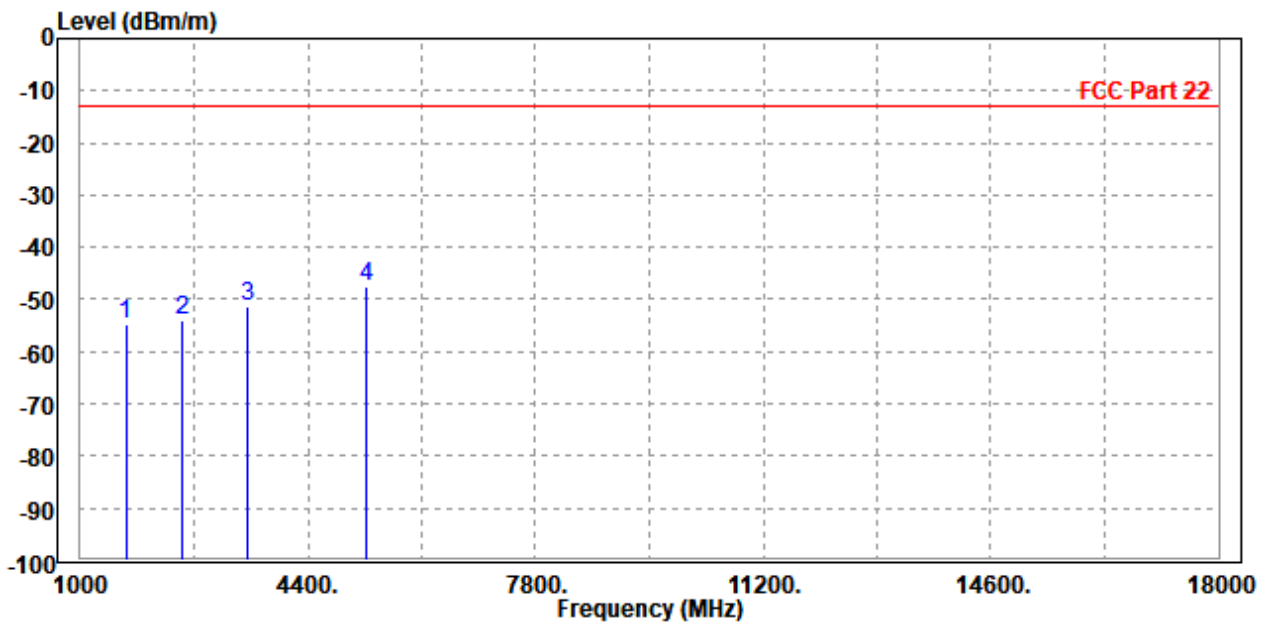

3.7 PEAK TO AVERAGE RATIO

3.7.1 LIMITS OF PEAK TO AVERAGE RATIO MEASUREMENT

In measuring transmissions in this band using an average power technique, the peak to-average ratio (PAR) of the transmission may not exceed 13 dB

3.7.2 TEST SETUP

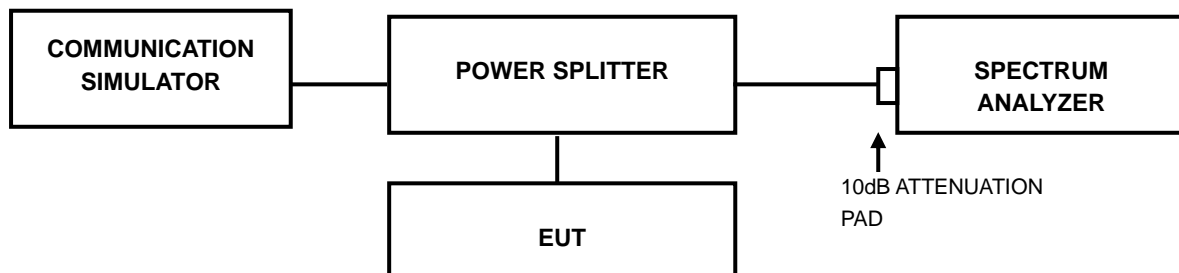

3.7.3 TEST PROCEDURES

1. Set resolution/measurement bandwidth \geq signal's occupied bandwidth;
2. Set the number of counts to a value that stabilizes the measured CCDF curve;
3. Record the maximum PAPR level associated with a probability of 0.1%.



**BUREAU
VERITAS**

Test Report No.: W7L-240430W002RF02

3.7.4 TEST RESULTS

Please Refer to Appendix B Of this test report.



**BUREAU
VERITAS**

Test Report No.: W7L-240430W002RF02

4 PHOTOGRAPHS OF THE TEST CONFIGURATION

Please refer to the attached file (Test Setup Photo).



**BUREAU
VERITAS**

Test Report No.: W7L-240430W002RF02

5 INFORMATION ON THE TESTING LABORATORIES

We, BV 7LAYERS COMMUNICATIONS TECHNOLOGY (SHENZHEN) CO. LTD., were founded in 2015 to provide our best service in EMC, Radio, Telecom and Safety consultation. Our laboratories are accredited and approved according to ISO/IEC 17025.

If you have any comments, please feel free to contact us at the following:

Shenzhen EMC/RF Lab:

Tel: +86-755-88696566

Fax: +86-755-88696577

Email: customerservice.sw@bureauveritas.com

Web Site: www.adt.com.tw

The address and road map of all our labs can be found in our web site also.



**BUREAU
VERITAS**

Test Report No.: W7L-240430W002RF02

6 MODIFICATIONS RECORDERS FOR ENGINEERING CHANGES TO THE EUT BY THE LAB

No any modifications are made to the EUT by the lab during the test.

---END---