

Document: **User Manual**

Product: **GM OnStar Gen12**  
Telematics Connectivity Platform Module (TCP)

Model: **G12N510G1**  
**G12N500G1**

Date: 25. May 2023

Public

---

## Content

<b>1</b>	<b>SCOPE OF DOCUMENT</b> .....	<b>3</b>
<b>2</b>	<b>GENERAL PRODUCT INFORMATION</b> .....	<b>3</b>
2.1	PRODUCT TYPE: .....	3
2.2	MANUFACTURER, APPLICANT: .....	3
2.3	BRAND/TRADEMARK: .....	3
2.4	FACTORY/MANUFACTURING LOCATION: .....	3
2.5	COUNTRY OF ORIGIN: .....	3
<b>3</b>	<b>SYSTEM OVERVIEW</b> .....	<b>4</b>
3.1	SHORT DESCRIPTION OF THE TCP .....	4
<b>4</b>	<b>NORTH AMERICA (NA) VARIANTS</b> .....	<b>4</b>
<b>5</b>	<b>MECHANICAL DESIGN</b> .....	<b>5</b>
5.1	PICTURES OF THE HOUSING .....	5
<b>6</b>	<b>DESCRIPTION OF THE TCP</b> .....	<b>6</b>
6.1	PRODUCT FEATURES .....	6
6.2	WIRELESS SERVICES: .....	7
6.3	TCP EXTERNAL ANTENNAS: .....	7
6.4	TCP INTERNAL ANTENNAS: .....	8
6.5	CONNECTORS: .....	8
6.5.1	<i>X1 20-Pin Main Connector Pin Out</i> .....	9
6.5.2	<i>X2 12-Pin Audio Connector Pin Out</i> .....	9
6.5.3	<i>X3 Quad RF Connector</i> .....	9
6.5.4	<i>X6 Single RF Connector (Present only when V2X is supported)</i> .....	9
6.5.5	<i>X7 1000BASET1 Connector</i> .....	10
6.6	AUDIO SUBSYSTEM .....	10
6.7	KEYPAD SUBSYSTEM .....	10
<b>7</b>	<b>TECHNICAL DATA</b> .....	<b>11</b>
7.1	OPERATING TEMPERATURE RANGE .....	11
7.2	SUPPLY VOLTAGE .....	11
7.3	SUPPLY CURRENT CONSUMPTION .....	11
7.4	POWER CONSUMPTION .....	11
<b>8</b>	<b>VEHICLE RF CABLE LOSS</b> .....	<b>12</b>
<b>9</b>	<b>WIRELESS SERVICES</b> .....	<b>12</b>
9.1	3G/WCDMA: .....	12
9.2	4G/LTE: .....	12
9.3	5G: .....	13
9.4	3G, 4G, 5G ANTENNA USAGE .....	14
9.4.1	<i>5G Uplink MIMO</i> .....	14
9.4.2	<i>5G SISO</i> .....	14
9.5	GNSS RECEIVER: .....	15
<b>10</b>	<b>PRODUCT LABEL INFORMATION</b> .....	<b>16</b>
10.1	USA/CANADA .....	16
<b>11</b>	<b>OWNER MANUAL STATEMENTS</b> .....	<b>16</b>
11.1	OWNER MANUAL USA/CANADA .....	16

Public	USER MANUAL	
Version: 3      Model G12N510G1, G12N500G1		Page 2 / 17

## 1 Scope of Document

The aim of this document is to provide a short overview on the Telematics Connectivity Platform Module (TCP) of model G12N510G1, G12N500G1 and to describe the TCP.

## 2 General Product Information

### 2.1 Product type:

Telematics Connectivity Platform Module (TCP)

### 2.2 Manufacturer, Applicant:

Continental Automotive Systems, Inc.  
21440 West Lake Cook Road  
Deer Park, IL 60010  
United States of America

### 2.3 Brand/Trademark:

Continental

### 2.4 Factory/Manufacturing Location:

Continental Automotive Maquila Mexico, S. de R.L. de C.V.  
Carretera Panamericana Sur No, Ext. 114+354 No. Int. 9  
Colonia: Parque Industrial Finsa Aguascalientes C.P. 20393

### 2.5 Country of origin:

Mexico

Public	USER MANUAL	
Version: 3      Model G12N510G1, G12N500G1		Page 3 / 17

### 3 SYSTEM OVERVIEW

#### 3.1 Short Description of the TCP

The product described herein is a Telematics Connectivity Platform Module (TCP) for the GM's GEN12 ONSTAR (Telematics and Connectivity Platform) program. It consists of integrated telematics transceivers for different wireless services, as well as several interfaces to the vehicle. The TCP is providing various connectivity services.

### 4 North America (NA) Variants

TCP Variant	TCP Model number	NAD Model Number
TCP NA	G12N510G1	FE5NA0010
TCP NA	G12N500G1	FE5NA0011

Public	USER MANUAL	
Version: 3      Model G12N510G1, G12N500G1		Page 4 / 17

## 5 Mechanical design

### 5.1 Pictures of the housing

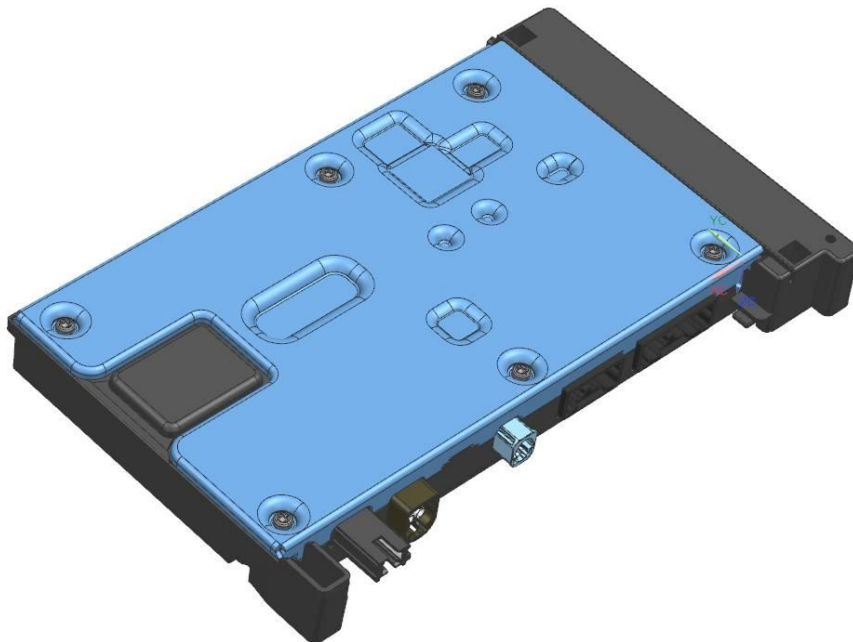
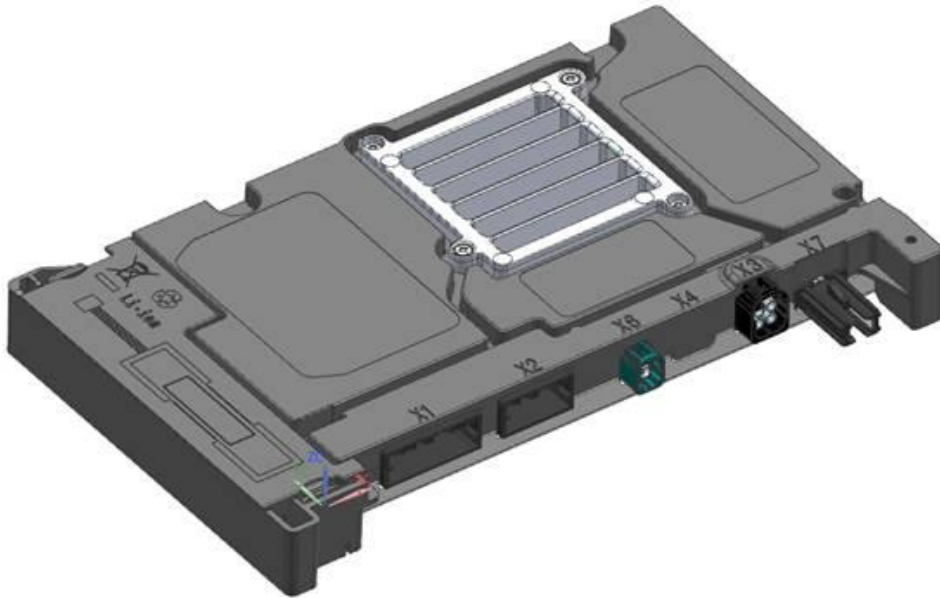

Public	USER MANUAL	
Version: 3    Model G12N510G1, G12N500G1		Page 5 / 17

## 6 Description of the TCP

### 6.1 Product features

The TCP main parts are:

- NAD with 3G/4G/5G and GNSS
- External and internal antennas
- Voice and Data
- 4G: 4x4 DL-MIMO
- 5G: 4x4 MIMO for DL and 2x2 MIMO for UL
- Internal embedded Sim-IC
- Audio subsystem includes analog microphone input and speaker output
- Digital audio interfaces including CODEC and audio PA (Power Amplifier)
- Service calls
- Emergency calls
- Internal Backup Battery (BUB)
- GNSS L1/L5
- Glonass, Beidou, Galileo, GPS

External interfaces:

- Main power supply
- Primary LTE antennas
- GPS Input
- Three buttons keypad
- LED control
- External microphone (MIC+/-) input/output
- External backup speaker (SPK+/-) output
- CAN
- Ethernet 1000BaseT1
- Debug interfaces (USB, UART)

Public	USER MANUAL	
Version: 3      Model G12N510G1, G12N500G1		Page 6 / 17

Ethernet:

Model number	Speed
G12N510G1	1 Gbit/s
G12N500G1	1 Gbit/s

## 6.2 Wireless services:

- 3G/WCDMA
- 4G/LTE
- 5G
- VoLTE
- Voice/Assistance Calls
  - Emergency Calls
  - Assistance Calls
  - Calls are only possible to some fixed phone numbers
- Global Positioning and Navigation: GPS, GNSS, Beidou, Glonass
- Data Services

## 6.3 TCP external Antennas:

- Cell ANT1: 3G/LTE1/5G (outside vehicle), primary external
- Cell ANT2: LTE2 (Rx LTE only)/5G (outside vehicle), secondary external
- GNSS patch (outside vehicle)
- XM patch (outside vehicle)

Public	USER MANUAL	
Version: 3      Model G12N510G1, G12N500G1		Page 7 / 17

#### 6.4 TCP internal Antennas:

- Cell/Backup ANT3, internal ANT1: 3G/4G/LTE1 (inside vehicle), primary internal
- Cell/Backup ANT4, internal ANT2: 4G/LTE2 (Rx LTE only) (inside vehicle), secondary internal

#### 6.5 Connectors:

The TCP has 6 types (fully featured variants) of connectors (from left to right):

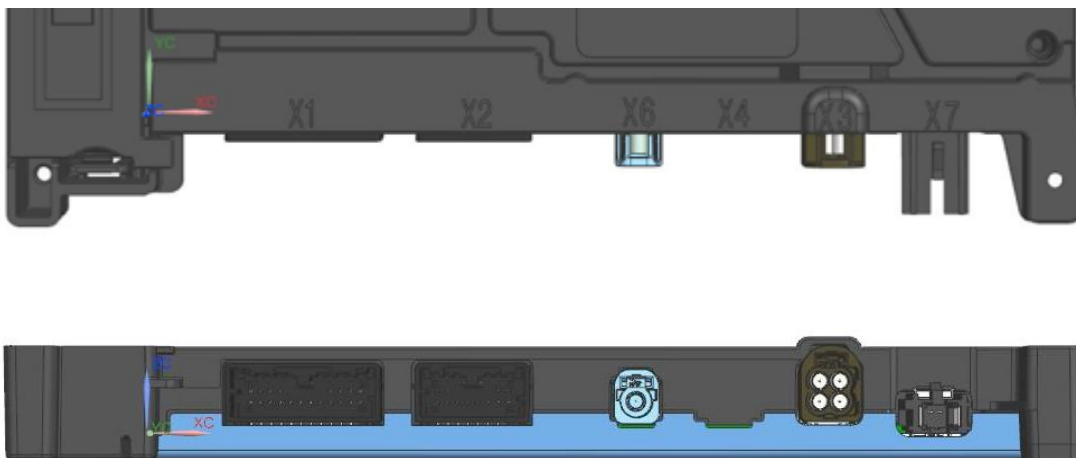

- X1: 20-Pin Main Signal Connector
- X2: 12-Pin Audio
- (X6: Single RF: C-V2X-2)
- X3: Quad RF (Cellular PRIMARY, DRX0, GNSS, C-V2X-1)
- X7: 1000BASET1

**This variant does not support V2X. Therefore, it does not have the X6 connector or CV2X-1 signal populated.**

Public	USER MANUAL	
Version: 3      Model G12N510G1, G12N500G1		Page 8 / 17



### 6.5.1 X1 20-Pin Main Connector Pin Out

Pin	Signal	Pin	Signal	Pin	Signal
1	VBATT	8	CAN_L (IN)	15	
2	VBATT	9	GND	16	
3	10V_REF	10	GND	17	
4	Keypad_IN	11		18	GND
5	Green_LED	12		19	CAN_H (OUT)
6	Red_LED	13		20	CAN_L (OUT)
7	CAN_H (IN)	14		*Continental Debug Signals	

### 6.5.2 X2 12-Pin Audio Connector Pin Out

Pin	Signal	Pin	Signal
1	SPKR_P	7	MIC_OUT_N
2	SPKR_N	8	MIC_IN_P
3	Not Connected	9	MIC_IN_N
4	Not Connected	10	MIC Shield
5	GND	11	GND
6	MIC_OUT_P	12	GND

### 6.5.3 X3 Quad RF Connector

Pin	Signal
1	GNSS
2	V2X_1
3	DRX0/5G Tx2
4	Primary

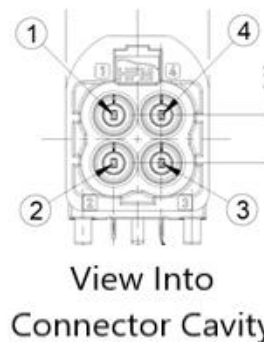

### 6.5.4 X6 Single RF Connector (Present only when V2X is supported)

Pin	Signal
1	V2X_2

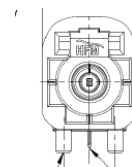

### 6.5.5 X7 1000BASET1 Connector

Pin	Signal
1	1000BASET1+
2	1000BASET1-

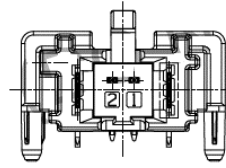

## 6.6 Audio Subsystem

The TCP audio system will provide a hands-free user interface for emergency calls and call center concierge/personal calling within the vehicular environment.

The audio system provides the following:

- Microphone front end input
- Amplifier speaker driver (class D amplifier)

## 6.7 Keypad Subsystem

The keypad subsystem will provide an interface between the user and the TCP for emergency calls and call center concierge/personal calling within the vehicular environment.

The keypad includes the following interfaces:

- Three button interfaces
  - Phone Button
    - Accept an incoming phone call
    - End a phone call
    - Initiate OnStar Screen on the infotainment unit
  - OnStar Button
    - Initiate an OnStar phone call to the Backoffice
  - Emergency Button
    - Initiate an Emergency phone call to the Backoffice
- Two color indicator LED's:
  - Green
  - Red

Public	USER MANUAL	
Version: 3    Model G12N510G1, G12N500G1		Page 10 / 17

## 7 Technical data

### 7.1 Operating temperature Range

-40°C to 90°C

### 7.2 Supply Voltage

Nominal.: 12 V dc

Supply Voltage Range: 6 V to 18 V dc

### 7.3 Supply current consumption

Typical standby current: 250mA dc, (at 12 V)

Typical active current consumption: 350mA dc, (at 12 V)

Maximum active current consumption: 600mA dc, (at 12 V)

### 7.4 Power Consumption

Typical power consumption: 5.5W  
(Cellular, GNSS active)

Public	USER MANUAL	
Version: 3      Model G12N510G1, G12N500G1		Page 11 / 17

## 8 Vehicle RF cable loss

The minimum RF cable loss in the vehicle for band n78 is 0.81 dB.

## 9 Wireless services

### 9.1 3G/WCDMA:

<b>Wireless service:</b>	<b>3G/WCDMA</b>
<b>Frequency bands / range:</b>	Band 2 (1900 UMTS): 1850-1910 / 1930-1990 MHz, Band 4 (1700 UMTS): 1710-1755 / 2110-2155 MHz, Band 5 (850 UMTS): 824-849 / 869-894 MHz
<b>Electrical output power (conducted into 50 Ohm):</b>	+23.0 dBm +1.0/-2.0 dB

### 9.2 4G/LTE:

<b>Wireless service:</b>	<b>4G/LTE</b>
<b>Frequency bands / range:</b>	FDD Band 2 (1900 LTE): 1850-1910 / 1930-1990 MHz, FDD Band 4 (1700 LTE): 1710-1755 / 2110-2155 MHz, FDD Band 5 (850 LTE): 824-849 / 869-894 MHz, FDD Band 7 (2600 LTE): 2500-2570 / 2620-2690 MHz, FDD Band 12 (700 LTE): 699-716 / 729-746 MHz, FDD Band 13 (750 LTE): 777-787 / 746-756 MHz, FDD Band 14 (700 LTE): 788-798 / 758-768 MHz, FDD Band 28a (700 LTE): 703-718 / 758-773 MHz, FDD Band 28b (700 LTE): 718-748 / 773-803 MHz, FDD Band 29Rx (700 LTE): - / 717-728 MHz, FDD Band 30Rx (2300 LTE): - / 2350-2360 MHz, FDD Band 66 (1700 LTE): 1710-1780 / 2110-2200 MHz, FDD Band 71 (600): 663-698 / 617-652 MHz
<b>Electrical output power (conducted into 50 Ohm):</b>	+23.0 dBm +1.0/-2.0 dB

Public	USER MANUAL	
Version: 3      Model G12N510G1, G12N500G1		Page 12 / 17

### 9.3 5G:

<b>Wireless service:</b>	<b>5G</b>
<b>Frequency bands / range:</b>	Band n2 (1900): 1850-1910 / 1930-1990 MHz, Band n5 (850): 824-849 / 869-894 MHz, Band n25 (1900): 1850-1915 / 1930-1995 MHz, Band n41 (2500): 2496-2690 MHz, Band n66 (1700): 1710-1780 / 2110-2200 MHz, Band n71 (600): 663-698 / 617-652 MHz, Band n77 (3700): 3300-4200 MHz Band n78 (3500): 3300-3800 MHz
<b>Electrical output power (conducted into 50 Ohm):</b>	Band n2: PC3: +23.0 dBm +1.0/-2.0 dB Band n5: PC3: +23.0 dBm +1.0/-2.0 dB Band n25: PC3: +23.0 dBm +1.0/-2.0 dB Band n41: PC2: +26.0 dBm +1.0/-2.0 dB Band n66: PC3: +23.0 dBm +1.0/-2.0 dB Band n71: PC3: +23.0 dBm +1.0/-2.0 dB Band n77: PC2: +26.0 dBm +1.0/-2.0 dB Band n78: PC3: +23.0 dBm +1.0/-2.0 dB *)

\*) To meet the requirement for radiated power from the vehicle antenna when using maximum power in Band n78, a reduction of 2.5dB of max tune-up power is needed. This power back-off is accomplished by using the SAR power limit feature. The SAR power limit is checked against the general power limit table prior to transmitting in any band when an external antenna connection is detected (normal state of operation.) Therefore, for Band n78, the SAR power limit table will contain a value 2.5dB lower than the general power limit table in use on the module. There is no effect to tune-up process or management of appropriate band output power to maintain proper connection within the allowed power range (given this 2.5dB reduction of the maximum allowed power).

The total loss in the vehicle to be declared is 5.81 dB.

$$\text{Power\_back-off} = 2.5 \text{ dB}$$

$$\text{LC} = 0.81_{\text{vehicle\_cable\_loss}} + 2.5_{\text{TCU\_board\_loss}} + \text{Power\_back-off}_{\text{mimo}}$$

$$\text{LC}_{\text{siso\_declare}} = \text{LC}_{\text{mimo\_declare}} = 5.81\text{dB}$$

Public	USER MANUAL	
Version: 3      Model G12N510G1, G12N500G1		Page 13 / 17

## 9.4 3G, 4G, 5G antenna usage

ANT1			ANT2		
3G/4G	5G NSA	5G SA	3G/4G	5G NSA	5G SA
All 3G and 4G bands	n2, n5, n66	n25, n41, n66, n71, n77, n78	---	n77, n78	n41, n77, n78

### 9.4.1 5G Uplink MIMO

MIMO	
Frequency Bands	Transmit antenna
41	primary antenna, secondary antenna
77	primary antenna, secondary antenna
78	primary antenna, secondary antenna

### 9.4.2 5G SISO

SISO	
Frequency Bands	Transmit antenna
2	primary antenna
5	primary antenna
25	primary antenna
41	secondary antenna
66	primary antenna
71	primary antenna
77	secondary antenna
78	secondary antenna

Public	USER MANUAL	
Version: 3    Model G12N510G1, G12N500G1		Page 14 / 17

### 9.5 GNSS receiver:

Model number	GNSS
G12N510G1	L1/L5
G12N500G1	L1

Wireless service:	GNSS Receiver
<p><b>Frequency bands / range:</b></p>	<p>L1: GNSS L1 Frequency Band: Beidou-B1I, GalileoE1, GLONASS-G1, GPS-L1 and SBAS-L1</p> <p>L5: GNSS L5 Frequency Band: Galileo-E5A and GPS-L5, Beidou-B2A</p> <p>SBAS supported: EGNOS/MSAS/QZSS/WAAS/GAGAN</p> <p>AGNSS not supported.</p>

Public	USER MANUAL	
Version: 3      Model G12N510G1, G12N500G1		Page 15 / 17

## 10 Product Label Information

### 10.1 USA/Canada

Model: G12N510G1 or G12N500G1  
 Contains FCC ID: LHJ-FE5NA0010  
 Contains IC: 2807E-FE5NA0010

## 11 Owner Manual Statements

### 11.1 Owner manual USA/Canada

Continental  
 Model: G12N510G1 or G12N500G1  
 Contains FCC ID: LHJ-FE5NA0010  
 Contains IC: 2807E-FE5NA0010

This device complies with Part 15 of the FCC Rules and Industry Canada licence-exempt RSS standard(s). Operation is subject to the following two conditions: (1) this device may not cause interference, and (2) this device must accept any interference, including interference that may cause undesired operation of the device.

*Le présent appareil est conforme aux CNR d'Industrie Canada applicables aux appareils radio exempts de licence. L'exploitation est autorisée aux deux conditions suivantes : (1) l'appareil ne doit pas produire de brouillage, et (2) l'utilisateur de l'appareil doit accepter tout brouillage radioélectrique subi, même si le brouillage est susceptible d'en compromettre le fonctionnement.*

This device complies with FCC/ISED radiation exposure limits set forth for an uncontrolled environment and meets the FCC radio frequency (RF) Exposure Guidelines and RSS-102 of the ISED radio frequency (RF) Exposure rules. **This transmitter must not be co-located or operating in conjunction with any other antenna or transmitter.**

**The TCP, containing internal radiating antennas, must be installed and mounted on a metal surface of the vehicles body in the intended plastic TCP bracket/holder for the intended car line variant.**

**The user shall keep a minimum distance to the TCP of 24 cm.**

**The user shall keep a minimum distance to antennas, residing on the car roofs, connected to the TCP, of 24 cm.**

*Le présent appareil est conforme à l'exposition aux radiations FCC / ISED définies pour un environnement non contrôlé et répond aux directives d'exposition de la fréquence de la FCC radiofréquence (RF) et RSS-102 de la fréquence radio (RF) ISED règles d'exposition.*

*L'émetteur ne doit pas être colocalisé ni fonctionner conjointement avec à autre antenne ou autre émetteur.*

*Le TCP, contenant antennes rayonnantes internes, doit être installé et monté sur une surface métallique de la carrosserie du véhicule dans le support TCP en plastique prévu pour la variante de ligne de voiture prévue.*

Public	USER MANUAL	
Version: 3      Model G12N510G1, G12N500G1		Page 16 / 17



---

*L'utilisateur doit garder une distance minimale au TCP de 24 cm.*

*L'utilisateur doit garder une distance minimale aux antennes, résidant sur les toits des voitures, connectées au TCP, de 24 cm.*

### **FCC Class B digital device notice**

This equipment has been tested and found to comply with the limits for a Class B digital device, pursuant to part 15 of the FCC Rules. These limits are designed to provide reasonable protection against harmful interference in a residential installation. This equipment generates, uses and can radiate radio frequency energy and, if not installed and used in accordance with the instructions, may cause harmful interference to radio communications. However, there is no guarantee that interference will not occur in a particular installation. If this equipment does cause harmful interference to radio or television reception, which can be determined by turning the equipment off and on, the user is encouraged to try to correct the interference by one or more of the following measures:

- Reorient or relocate the receiving antenna.
- Increase the separation between the equipment and receiver.
- Connect the equipment into an outlet on a circuit different from that to which the receiver is connected.
- Consult the dealer or an experienced radio/TV technician for help.

Continental Automotive Systems, Inc. has not approved any changes or modifications to this device by the user. Any changes or modifications could void the user's authority to operate the equipment.

*Continental Automotive Systems, Inc n'approuve aucune modification apportée à l'appareil par l'utilisateur, quelle qu'en soit la nature. Tout changement ou modification peuvent annuler le droit d'utilisation de l'appareil par l'utilisateur.*

### **CAN ICES-3 (B) / NMB-3 (B)**

This Class B digital apparatus complies with Canadian ICES-003.

*Cet appareil numérique de classe B est conforme à la norme canadienne ICES-003.*

---

END OF DOCUMENT

---

Public	USER MANUAL	
Version: 3      Model G12N510G1, G12N500G1		Page 17 / 17