

Document: **User Manual**

Product: **GM OnStar Gen12**
Telematics Control Unit (TCP)

Model: **G12N410G1**
G12N410M1

Date: 19. June 2023

Content

1	SCOPE OF DOCUMENT	3
2	GENERAL PRODUCT INFORMATION.....	3
2.1	PRODUCT TYPE:.....	3
2.2	MANUFACTURER, APPLICANT:.....	3
2.3	BRAND/TRADEMARK:	3
2.4	FACTORY/MANUFACTURING LOCATION:	3
2.5	COUNTRY OF ORIGIN:	3
3	SYSTEM OVERVIEW.....	4
3.1	SHORT DESCRIPTION OF THE TCAM.....	4
4	NORTH AMERICA (NA) VARIANTS.....	4
5	MECHANICAL DESIGN	5
5.1	PICTURES OF THE HOUSING.....	5
6	DESCRIPTION OF THE TCP	6
6.1	PRODUCT FEATURES.....	6
6.2	WIRELESS SERVICES:.....	7
6.3	TCP EXTERNAL ANTENNAS:.....	7
6.4	TCP INTERNAL ANTENNAS:	7
6.5	CONNECTORS	8
6.5.1	<i>X1 20-Pin Main Connector Pin Out.....</i>	<i>8</i>
6.5.2	<i>X2 12-Pin Audio and 100BASET1 Connector Pin Out</i>	<i>9</i>
6.5.3	<i>X3 Quad RF Connector.....</i>	<i>9</i>
6.5.4	<i>X6 Single RF Connector.....</i>	<i>9</i>
6.5.5	<i>X7 1000BASET1 Connector.....</i>	<i>9</i>
6.6	AUDIO SUBSYSTEM	10
6.7	KEYPAD SUBSYSTEM.....	10
7	TECHNICAL DATA	11
7.1	OPERATING TEMPERATURE RANGE	11
7.2	SUPPLY VOLTAGE	11
7.3	SUPPLY CURRENT CONSUMPTION	11
7.4	POWER CONSUMPTION	11
8	WIRELESS SERVICES	12
8.1	3G/WCDMA:	12
8.2	4G/LTE:.....	12
8.3	GNSS RECEIVER:	12
9	LABEL INFORMATION.....	13
9.1	USA/CANADA.....	13
10	OWNER MANUAL STATEMENTS	13
10.1	OWNER MANUAL USA/CANADA.....	13

USER MANUAL		
Version: 1	G12N410G1, G12N410M1	Page 2 / 14

1 Scope of Document

The aim of this document is to provide a short overview on the Telematics Control Unit (TCP) of model G12N410G1 and G12N410M1 and to describe the TCP.

2 General Product Information

2.1 Product type:

Telematics Control Unit (TCP)

2.2 Manufacturer, Applicant:

Continental Automotive GmbH
Siemensstrasse 12
93055 Regensburg
Germany

2.3 Brand/Trademark:

Continental

2.4 Factory/Manufacturing Location:

Continental Automotive Maquila Mexico, S. de R.L. de C.V.
Carretera Panamericana Sur No, Ext. 114+354 No. Int. 9
Colonia: Parque Industrial Finsa Aguascalientes C.P. 20393

2.5 Country of origin:

Mexico

USER MANUAL		
Version: 1 G12N410G1, G12N410M1		Page 3 / 14

3 System Overview

3.1 Short Description of the TCAM

The product described herein is a Telematics control unit (TCP) for the GM's GEN12 ONSTAR (Telematics and Connectivity Platform) program. It consists of integrated telematics transceivers for different wireless services, as well as several interfaces to the vehicle. ONSTAR is providing various connectivity services.

4 North America (NA) Variants

TCP Variant	TCP Model number	NAD Model Number
TCP NA	G12N410G1	FE4NA0210
TCP NA	G12N410M1	FE4NA0210

USER MANUAL		
Version: 1 G12N410G1, G12N410M1		Page 4 / 14

5 Mechanical design

5.1 Pictures of the housing

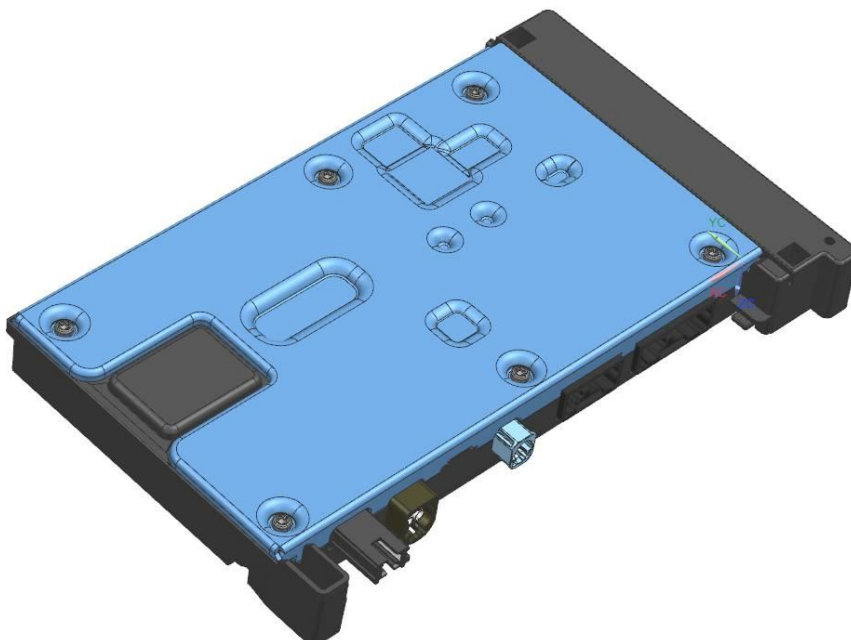
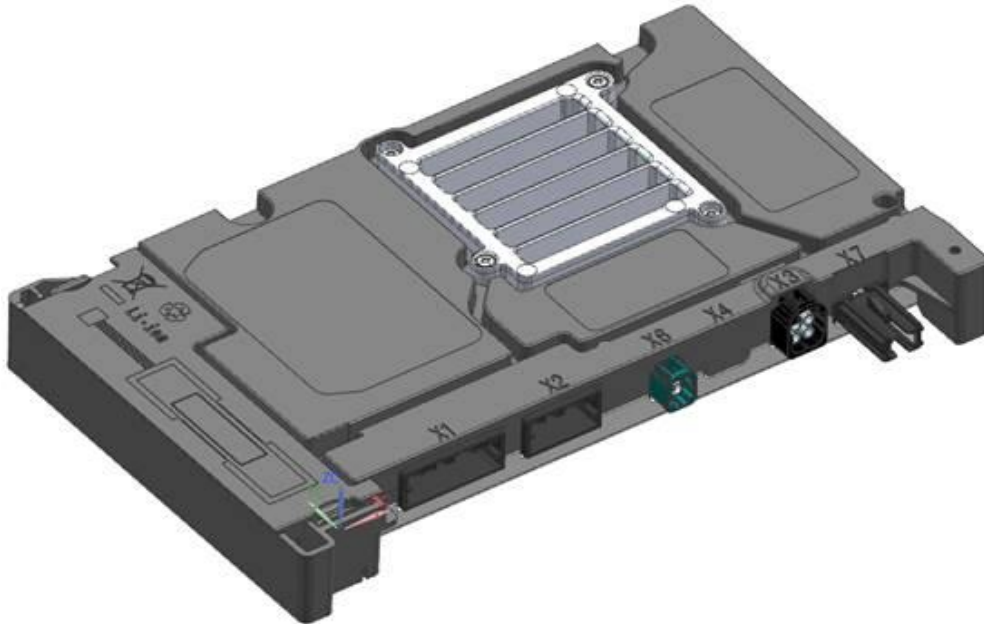

USER MANUAL		
Version: 1 G12N410G1, G12N410M1		Page 5 / 14

6 Description of the TCP

6.1 Product features

The model main parts are:

- NAD with 3G/4G/LTE and GNSS
- External and internal antennas
- Voice and Data
- Glonass, Beidou, Galileo, GPS
- 2x2 DL-MIMO for 4G
- internal embedded Sim-IC
- Audio subsystem includes analog microphone input and speaker output
- Digital audio interfaces including CODEC and audio PA (Power Amplifier)
- Service calls
- Emergency calls
- Internal Backup Battery (BUB)
- High precision GNSS L1/L5

External interfaces:

- Main power supply
- Primary LTE antennas
- GPS Input
- Three button key pad
- LED control
- External microphone (MIC+/-) input/output
- External backup speaker (SPK+/-) output
- CAN
- Ethernet 100BaseT1 or 1000BaseT1
- Debug interfaces (USB, UART)

USER MANUAL		
Version: 1 G12N410G1, G12N410M1		Page 6 / 14

Ethernet:

Model number	Speed
G12N410G1	1 GB
G12N410M1	100 MB

6.2 Wireless services:

- 3G/WCDMA
- 4G/LTE
- VoLTE
- Voice/Assistance Calls
 - Emergency Calls
 - Assistance Calls
 - Calls are only possible to some fixed phone numbers
- Global Positioning and Navigation: GPS, GNSS, Beidou, Glonass
- Data Services

6.3 TCP external Antennas:

- Cell ANT1: 3G/LTE1 (outside vehicle), primary external
- Cell ANT2: LTE2 (Rx LTE only, outside vehicle), secondary external
- GNSS patch (outside vehicle)
- XM patch (outside vehicle)

6.4 TCP internal Antennas:

- Cell/Backup ANT3, internal ANT1: 3G/4G/LTE1 (inside vehicle), primary internal
- Cell/Backup ANT4, internal ANT2: 4G/LTE2 (Rx LTE only, inside vehicle), secondary internal

USER MANUAL		
Version: 1 G12N410G1, G12N410M1		Page 7 / 14

6.5 Connectors

The GM GEN12 TCP has 6 types (fully featured) of connectors (from left to right):

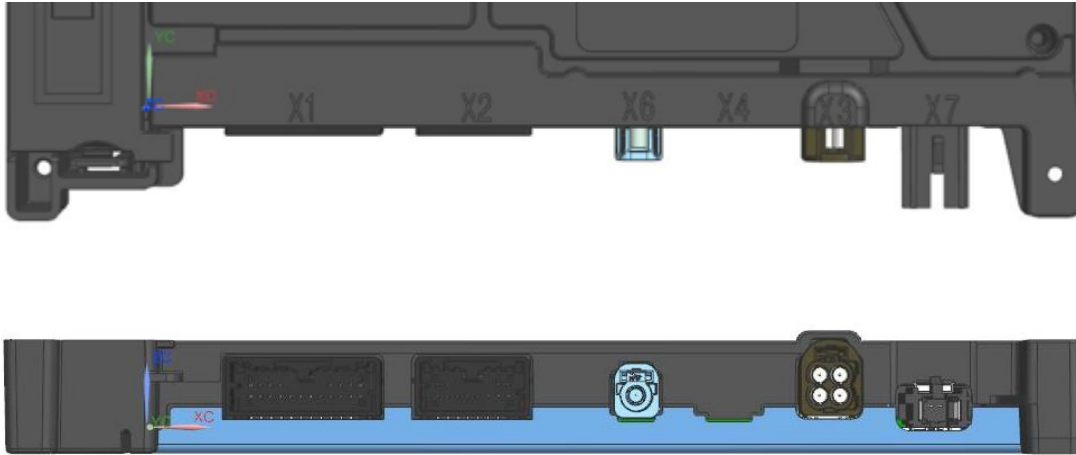

- X1: 20-Pin Main Signal Connector
- X2: 12-Pin Audio and 100BASET1
- X6: Single RF: C-V2X-2
- X3: Quad RF (Cellular PRIMARY, DRX0/GNSS, C-V2X-1)
- X7: 1000BASET1

These variants do not support V2X. Therefore, they do not have the X6 connector and C-V2X-1 signal populated.

6.5.1 X1 20-Pin Main Connector Pin Out

Pin	Signal	Pin	Signal	Pin	Signal
1	VBATT	8	CAN_L (IN)	15	
2	VBATT	9	GND	16	
3	10V_REF	10	GND	17	
4	Keypad_IN	11		18	GND
5	Green_LED	12		19	CAN_H (OUT)
6	Red_LED	13		20	CAN_L (OUT)
7	CAN_H (IN)	14		*Continental Debug Signals	

USER MANUAL		
Version: 1	G12N410G1, G12N410M1	Page 8 / 14

6.5.2 X2 12-Pin Audio and 100BASET1 Connector Pin Out

Pin	Signal		Pin	Signal
1	SPKR_P		7	MIC_OUT_N
2	SPKR_N		8	MIC_OUT_P
3	100BT1_M		9	MIC_OUT_N
4	100BT1_P		10	MIC Shield
5	GND		11	GND
6	MIC_OUT_P		12	GND

6.5.3 X3 Quad RF Connector

Pin	Signal
1	GNSS/DRX0
2	V2X_1
3	DRX0
4	Primary LTE

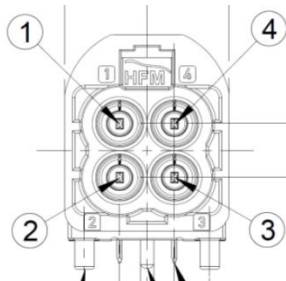

6.5.4 X6 Single RF Connector

Pin	Signal
1	V2X_2



At model G12N410G1 and model G12N410M1 TCP variants not populated.

6.5.5 X7 1000BASET1 Connector

Pin	Signal
1	1000BASET1+
2	1000BASET1-

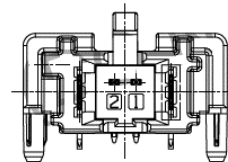

6.6 Audio Subsystem

The TCU audio system will provide a hands-free user interface for emergency calls and call center concierge/personal calling within the vehicular environment.

The audio system provides the following

- Microphone front end input
- Amplified speaker driver (class D amplifier)

6.7 Keypad Subsystem

The keypad subsystem will provide an interface between the user and the TCU for emergency calls and call center concierge/personal calling within the vehicular environment.

The keypad includes the following interfaces:

- Three button interfaces
 - Phone Button
 - Accept an incoming phone call
 - End a phone call
 - Initiate OnStar Screen on the infotainment unit
 - OnStar Button
 - Initiate an OnStar phone call to the Backoffice
 - Emergency Button
 - Initiate an Emergency phone call to the Backoffice
- Two color indicator LED's
 - Green
 - Red

USER MANUAL		
Version: 1 G12N410G1, G12N410M1		Page 10 / 14

7 Technical data

7.1 Operating temperature Range

-40°C to 90°C

7.2 Supply Voltage

Nominal.: 12 V dc

Supply Voltage Range: 8 V to 16 V dc

7.3 Supply current consumption

Typical standby current: 250mA (at 12 V)

Typical active current consumption: 350mA (at 12 V)

Maximum active current consumption: 600mA dc (at 12 V)

7.4 Power Consumption

Typical power consumption: 5.5W
(Cellular, GNSS active)

USER MANUAL		
Version: 1 G12N410G1, G12N410M1		Page 11 / 14

8 Wireless services

8.1 3G/WCDMA:

Wireless service:	3G/UMTS
Frequency bands / range:	Band II (B2: 1900 UMTS): 1850-1910 / 1930-1990 MHz, Band IV (B4: 1700 UMTS): 1710-1755 / 2110-2155 MHz, Band V (B5: 850 UMTS): 824-849 / 869-894 MHz
Electrical output power:	+23.0 dBm (+/- 1dB)

8.2 4G/LTE:

Wireless service:	4G/LTE
Frequency bands / range:	Band 2 (1900 LTE): 1850-1910 / 1930-1990 MHz, Band 4 (1700 LTE): 1710-1755 / 2110-2155 MHz, Band 5 (850 LTE): 824-849 / 869-894 MHz, Band 12 (700 LTE): 698-716 / 728-746 MHz, Band 13 (750 LTE): 777-787 / 746-756 MHz, Band 14 (700 LTE): 788-798 / 758-768 MHz, Band 28a (700 LTE): 703-718 / 758-773 MHz, Band 28b (700 LTE): 718-748 / 773-803 MHz, Band 29Rx (700 LTE): - / 717-728 MHz, Band 30Rx (2300 LTE): 2305-2317 / 2305-2360 MHz, Band 66 (1700 LTE): 1710-1780 / 2110-2200 MHz
Electrical output power:	+23.0 dBm (+/- 1dB)

8.3 GNSS receiver:

Wireless service:	GNSS Receiver
Frequency bands / range:	L1/L5 L1: GNSS L1 Frequency Band: Beidou-B1I, GalileoE1, GLONASS-G1, GPS-L1 and SBAS-L1 SBAS supported: EGNOS/MSAS/QZSS/WAAS/GAGAN AGNSS not supported.

USER MANUAL		
Version: 1 G12N410G1, G12N410M1		Page 12 / 14

9 Label Information

9.1 USA/Canada

Model: G12N410G1 or G12N410M1
 Contains FCC ID: LHJ-FE4NA0210
 Contains IC: 2807E-FE4NA0210

10 Owner Manual Statements

10.1 Owner manual USA/Canada

Continental
 Model: G12N410G1 or G12N410M1
 Contains FCC ID: LHJ-FE4NA0210
 Contains IC: 2807E-FE4NA0210

This device complies with Part 15 of the FCC Rules and Industry Canada licence-exempt RSS standard(s). Operation is subject to the following two conditions: (1) this device may not cause interference, and (2) this device must accept any interference, including interference that may cause undesired operation of the device.

Le présent appareil est conforme aux CNR d'Industrie Canada applicables aux appareils radio exempts de licence. L'exploitation est autorisée aux deux conditions suivantes : (1) l'appareil ne doit pas produire de brouillage, et (2) l'utilisateur de l'appareil doit accepter tout brouillage radioélectrique subi, même si le brouillage est susceptible d'en compromettre le fonctionnement.

This device complies with FCC/ISED radiation exposure limits set forth for an uncontrolled environment and meets the FCC radio frequency (RF) Exposure Guidelines and RSS-102 of the ISED radio frequency (RF) Exposure rules. **This transmitter must not be co-located or operating in conjunction with any other antenna or transmitter.**

The TCP, containing internal radiating antennas, should be installed and mounted on a metal surface of the vehicles body in the intended plastic TCP bracket/holder for the intended car line variant.

When a TCP is mounted to a metal surface behind a seat, there shall be no occupants behind the TCP.

The user shall keep a minimum distance of 2.5 cm between the top side of the TCP, showing in the direction of human beings, and human beings.

The user shall keep a minimum distance to antennas, residing on the car roofs, connected to the TCP, of 2.5 cm.

Le présent appareil est conforme à l'exposition aux radiations FCC / ISED définies pour un environnement non contrôlé et répond aux directives d'exposition de la fréquence de la FCC radiofréquence (RF) et RSS-102 de la fréquence radio (RF) ISED règles d'exposition.

L'émetteur ne doit pas être colocalisé ni fonctionner conjointement avec à autre antenne ou autre émetteur.

USER MANUAL		
Version: 1 G12N410G1, G12N410M1		Page 13 / 14

Le TCP, contenant antennes rayonnantes internes, doit être installé et monté sur une surface métallique de la carrosserie du véhicule dans le support TCP en plastique prévu pour la variante de ligne de voiture prévue.

Lorsqu'un TCP est monté sur une surface métallique derrière un siège, il ne doit y avoir aucun occupant derrière le TCP.

L'utilisateur doit maintenir une distance minimale de 2.5 cm entre la face supérieure du TCP, orientée vers les êtres humains, et les êtres humains.

L'utilisateur doit garder une distance minimale aux antennes, résidant sur les toits des voitures, connectées au TCP, de 2.5 cm.

FCC Class B digital device notice

This equipment has been tested and found to comply with the limits for a Class B digital device, pursuant to part 15 of the FCC Rules. These limits are designed to provide reasonable protection against harmful interference in a residential installation. This equipment generates, uses and can radiate radio frequency energy and, if not installed and used in accordance with the instructions, may cause harmful interference to radio communications. However, there is no guarantee that interference will not occur in a particular installation. If this equipment does cause harmful interference to radio or television reception, which can be determined by turning the equipment off and on, the user is encouraged to try to correct the interference by one or more of the following measures:

- Reorient or relocate the receiving antenna.
- Increase the separation between the equipment and receiver.
- Connect the equipment into an outlet on a circuit different from that to which the receiver is connected.
- Consult the dealer or an experienced radio/TV technician for help.

Continental Automotive GmbH has not approved any changes or modifications to this device by the user. Any changes or modifications could void the user's authority to operate the equipment.

Continental Automotive GmbH n'approuve aucune modification apportée à l'appareil par l'utilisateur, quelle qu'en soit la nature. Tout changement ou modification peuvent annuler le droit d'utilisation de l'appareil par l'utilisateur.

CAN ICES-3 (B) / NMB-3 (B)

This Class B digital apparatus complies with Canadian ICES-003.

Cet appareil numérique de classe B est conforme à la norme canadienne ICES-003.

END OF DOCUMENT

USER MANUAL		
Version: 1 G12N410G1, G12N410M1		Page 14 / 14