

FCC Test Report (Part 27)

Report No.: RF190315C13-2

FCC ID: LHJ-BL28RW001

Test Model: BL28RW-001

Received Date: Mar. 15, 2019

Test Date: Apr. 02 ~ Apr. 08, 2019

Issued Date: Apr. 16, 2019

Applicant: Continental Automotive Systems

Address: 21440 West Lake Cook Road Deer Park, IL 60010 United States

Issued By: Bureau Veritas Consumer Products Services (H.K.) Ltd., Taoyuan Branch

Lab Address: No. 47-2, 14th Ling, Chia Pau Vil., Lin Kou Dist., New Taipei City, Taiwan (R.O.C.)

Test Location: No. 19, Hwa Ya 2nd Rd., Wen Hwa Vil., Kwei Shan Dist., Taoyuan City 33383, TAIWAN (R.O.C.)

FCC Registration / 788550 / TW0003

Designation Number:



This report is for your exclusive use. Any copying or replication of this report to or for any other person or entity, or use of our name or trademark, is permitted only with our prior written permission. This report sets forth our findings solely with respect to the test samples identified herein. The results set forth in this report are not indicative or representative of the quality or characteristics of the lot from which a test sample was taken or any similar or identical product specifically and expressly noted. Our report includes all of the tests requested by you and the results thereof based upon the information that you provided to us. You have 60 days from date of issuance of this report to notify us of any material error or omission caused by our negligence, provided, however, that such notice shall be in writing and shall specifically address the issue you wish to raise. A failure to raise such issue within the prescribed time shall constitute your unqualified acceptance of the completeness of this report, the tests conducted and the correctness of the report contents. Unless specific mention, the uncertainty of measurement has been explicitly taken into account to declare the compliance or non-compliance to the specification. The report must not be used by the client to claim product certification, approval, or endorsement by TAF or any government agency

Table of Contents

Release Control Record	4
1 Certificate of Conformity	5
2 Summary of Test Results	6
2.1 Measurement Uncertainty.....	6
2.2 Test Site and Instruments.....	7
3 General Information	8
3.1 General Description of EUT.....	8
3.2 Configuration of System under Test.....	10
3.2.1 Description of Support Units.....	10
3.3 Test Mode Applicability and Tested Channel Detail.....	11
3.4 EUT Operating Conditions.....	17
3.5 General Description of Applied Standards.....	17
4 Test Types and Results	18
4.1 Output Power Measurement.....	18
4.1.1 Limits of Output Power Measurement.....	18
4.1.2 Test Procedures.....	18
4.1.3 Test Setup.....	19
4.1.4 Test Results.....	20
4.2 Modulation Characteristics Measurement.....	62
4.2.1 Limits of Modulation Characteristics.....	62
4.2.2 Test Procedure.....	62
4.2.3 Test Setup.....	62
4.2.4 Test Results.....	63
4.3 Frequency Stability Measurement.....	66
4.3.1 Limits of Frequency Stability Measurement.....	66
4.3.2 Test Procedure.....	66
4.3.3 Test Setup.....	66
4.3.4 Test Results.....	67
4.4 Emission Bandwidth Measurement.....	78
4.4.1 Limits of Emission Bandwidth Measurement.....	78
4.4.2 Test Procedure.....	78
4.4.3 Test Setup.....	78
4.4.4 Test Result.....	79
4.5 Channel Edge Measurement.....	91
4.5.1 Limits of Band Edge Measurement.....	91
4.5.2 Test Setup.....	91
4.5.3 Test Procedures.....	91
4.5.4 Test Results.....	92
4.6 Peak to Average Ratio.....	103
4.6.1 Limits of Peak to Average Ratio Measurement.....	103
4.6.2 Test Setup.....	103
4.6.3 Test Procedures.....	103
4.6.4 Test Results.....	104
4.7 Conducted Spurious Emissions.....	110
4.7.1 Limits of Conducted Spurious Emissions Measurement.....	110
4.7.2 Test Setup.....	110
4.7.3 Test Procedure.....	110
4.7.4 Test Results.....	111
4.8 Radiated Emission Measurement.....	150
4.8.1 Limits of Radiated Emission Measurement.....	150
4.8.2 Test Procedure.....	150
4.8.3 Deviation from Test Standard.....	150
4.8.4 Test Setup.....	151

4.8.5 Test Results	152
5 Pictures of Test Arrangements.....	176
Appendix – Information of the Testing Laboratories	177

Release Control Record

Issue No.	Description	Date Issued
RF190315C13-2	Original release	Apr. 16, 2019

1 Certificate of Conformity

Product: BL28RW-001 Module

Brand: Continental

Test Model: BL28RW-001

Sample Status: Engineering sample

Applicant: Continental Automotive Systems

Test Date: Apr. 02 ~ Apr. 08, 2019

Standards: FCC Part 27, Subpart C, L, M

The above equipment has been tested by **Bureau Veritas Consumer Products Services (H.K.) Ltd., Taoyuan Branch**, and found compliance with the requirement of the above standards. The test record, data evaluation & Equipment Under Test (EUT) configurations represented herein are true and accurate accounts of the measurements of the sample's RF characteristics under the conditions specified in this report.

Prepared by : Pettie Chen, **Date:** Apr. 16, 2019
Pettie Chen / Senior Specialist

Approved by : Bruce Chen, **Date:** Apr. 16, 2019
Bruce Chen / Project Engineer

2 Summary of Test Results

Applied Standard: FCC Part 27 & Part 2				
FCC Clause		Test Item	Result	Remarks
WCDMA Band 4 / LTE Band 4	LTE Band 7			
2.1046 27.50(d)(4)	2.1046 27.50(h)(2)	Equivalent Isotropically Radiated Power	Pass	Meet the requirement of limit.
27.50(d)(5)	----	Peak To Average Ratio	Pass	Meet the requirement of limit.
2.1055 27.54	2.1055 27.54	Frequency Stability Stay with the authorized bands of operation	Pass	Meet the requirement of limit.
2.1049	2.1049 27.53(m)(6)	Emission Bandwidth	Pass	Meet the requirement of limit.
2.1051 27.53(h)	2.1051 27.53 (m)(4)(6)	Band Edge Measurements	Pass	Meet the requirement of limit.
2.1051 27.53(h)	2.1051 27.53 (m)(4)(6)	Conducted Spurious Emissions	Pass	Meet the requirement of limit.
2.1053 27.53(h)	2.1053 27.53 (m)(4)(6)	Radiated Spurious Emissions	Pass	Meet the requirement of limit. Minimum passing margin is -18.9dB at 5135.00MHz.

Note: Determining compliance based on the results of the compliance measurement, not taking into account measurement instrumentation uncertainty.

2.1 Measurement Uncertainty

Where relevant, the following measurement uncertainty levels have been estimated for tests performed on the EUT as specified in CISPR 16-4-2:

Measurement	Frequency	Expanded Uncertainty (k=2) (±)
Radiated Emissions up to 1 GHz	9kHz ~ 30MHz	3.04 dB
	30MHz ~ 200MHz	3.59 dB
	200MHz ~1000MHz	3.60 dB
Radiated Emissions above 1 GHz	1GHz ~ 18GHz	2.29 dB
	18GHz ~ 40GHz	2.29 dB

2.2 Test Site and Instruments

Description & Manufacturer	Model No.	Serial No.	Cal. Date	Cal. Due
Test Receiver KEYSIGHT	N9038A	MY55420137	Apr. 11, 2018	Apr. 10, 2019
Spectrum Analyzer ROHDE & SCHWARZ	FSP40	100269	May 29, 2018	May 28, 2019
BILOG Antenna SCHWARZBECK	VULB9168	9168-160	Nov. 21, 2018	Nov. 20, 2019
HORN Antenna SCHWARZBECK	BBHA 9120 D	9120D-1169	Nov. 25, 2018	Nov. 24, 2019
HORN Antenna SCHWARZBECK	BBHA 9170	BBHA9170241	Nov. 25, 2018	Nov. 24, 2019
Loop Antenna TESEQ	HLA 6121	45745	Jun. 14, 2018	Jun. 13, 2019
Preamplifier Agilent (Below 1GHz)	8447D	2944A10638	Aug. 08, 2018	Aug. 07, 2019
Preamplifier Agilent (Above 1GHz)	8449B	3008A02367	Feb. 19, 2019	Feb. 18, 2020
RF signal cable HUBER+SUHNER&EMCI	SUCOFLEX 104 & EMC104-SM-SM80 00	CABLE-CH9-02 (248780+171006)	Jan. 19, 2019	Jan. 18, 2020
RF signal cable HUBER+SUHNER	SUCOFLEX 104	CABLE-CH9-(250795/4)	Aug. 08, 2018	Aug. 07, 2019
RF signal cable Woken	8D-FB	Cable-CH9-01	Jul. 31, 2018	Jul. 30, 2019
Software BV ADT	ADT_Radiated_ V7.6.15.9.5	NA	NA	NA
Antenna Tower EMCO	2070/2080	512.835.4684	NA	NA
Turn Table EMCO	2087-2.03	NA	NA	NA
Antenna Tower & Turn BV ADT	AT100	AT93021705	NA	NA
Turn Table BV ADT	TT100	TT93021705	NA	NA
Turn Table Controller BV ADT	SC100	SC93021705	NA	NA
Boresight Antenna Fixture	FBA-01	FBA-SIP01	NA	NA
Pre-amplifier (18GHz-40GHz) EMC	EMC184045B	980175	Nov. 14, 2018	Nov. 13, 2019
WIT Standard Temperature And Humidity Chamber	TH-4S-C	W981030	Jun. 04, 2018	Jun. 03, 2019
JFW 20dB attenuation	50HF-020-SMA	NA	NA	NA

- Note: 1. The calibration interval of the above test instruments is 12 months and the calibrations are traceable to NML/ROC and NIST/USA.
2. The test was performed in HwaYa Chamber 9.
3. The FCC Designation Number is TW0003. The number will be varied with the Lab location and scope as attached.
4. The IC Site Registration No. is 7450F-9.

3 General Information

3.1 General Description of EUT

Product	BL28RW-001 Module				
Brand	Continental				
Test Model	BL28RW-001				
Status of EUT	Engineering sample				
Power Supply Rating	3.6 Vdc (Power supply)				
Modulation Type	WCDMA: BPSK, QPSK HSDPA: BPSK HSUPA: QPSK LTE: QPSK, 16QAM, 64QAM				
Operating Frequency	WCDMA Band 4		1712.4MHz ~ 1752.6MHz		
	LTE Band 4	Channel Bandwidth 1.4MHz	1710.7MHz ~ 1754.3MHz		
		Channel Bandwidth 3MHz	1711.5MHz ~ 1753.5MHz		
		Channel Bandwidth 5MHz	1712.5MHz ~ 1752.5MHz		
		Channel Bandwidth 10MHz	1715.0MHz ~ 1750.0MHz		
		Channel Bandwidth 15MHz	1717.5MHz ~ 1747.5MHz		
		Channel Bandwidth 20MHz	1720.0MHz ~ 1745.0MHz		
	LTE Band 7	Channel Bandwidth 5MHz	2502.5MHz ~ 2567.5MHz		
		Channel Bandwidth 10MHz	2505.0MHz ~ 2565.0MHz		
		Channel Bandwidth 15MHz	2507.5MHz ~ 2562.5MHz		
		Channel Bandwidth 20MHz	2510.0MHz ~ 2560.0MHz		
	Max. EIRP Power	WCDMA Band 4		190.546mW (26.8dBm)	
			QPSK	16QAM	64QAM
LTE Band 4		Channel Bandwidth 1.4MHz	426.580mW (26.3dBm)	338.884mW (25.3dBm)	309.030mW (24.9dBm)
		Channel Bandwidth 3MHz	354.813mW (25.5dBm)	316.228mW (25.0dBm)	281.838mW (24.5dBm)
		Channel Bandwidth 5MHz	354.813mW (25.5dBm)	309.030mW (24.9dBm)	281.838mW (24.5dBm)
		Channel Bandwidth 10MHz	398.107mW (26.0dBm)	309.030mW (24.9dBm)	288.403mW (24.6dBm)
		Channel Bandwidth 15MHz	407.380mW (26.1dBm)	288.403mW (24.6dBm)	263.027mW (24.2dBm)
		Channel Bandwidth 20MHz	407.380mW (26.1dBm)	316.228mW (25.0dBm)	288.403mW (24.6dBm)
LTE Band 7		Channel Bandwidth 5MHz	1023.293mW (30.1dBm)	812.831mW (29.1dBm)	724.436mW (28.6dBm)
		Channel Bandwidth 10MHz	1000.000mW (30.0dBm)	758.578mW (28.8dBm)	691.831mW (28.4dBm)
		Channel Bandwidth 15MHz	933.254mW (29.7dBm)	776.247mW (28.9dBm)	724.436mW (28.6dBm)
		Channel Bandwidth 20MHz	851.138mW (29.3dBm)	741.310mW (28.7dBm)	707.946mW (28.5dBm)

Emission Designator	WCDMA Band 4		4M15F9W		
			QPSK	16QAM	64QAM
	LTE Band 4	Channel Bandwidth 1.4MHz	1M09G7D	1M09D7W	1M09D7W
		Channel Bandwidth 3MHz	2M70G7D	2M70D7W	2M70D7W
		Channel Bandwidth 5MHz	4M49G7D	4M49D7W	4M49D7W
		Channel Bandwidth 10MHz	8M95G7D	8M96D7W	8M95D7W
		Channel Bandwidth 15MHz	13M4G7D	13M4D7W	13M4D7W
		Channel Bandwidth 20MHz	17M8G7D	17M9D7W	17M9D7W
	LTE Band 7	Channel Bandwidth 5MHz	4M49G7D	4M49D7W	4M50D7W
		Channel Bandwidth 10MHz	8M95G7D	8M96D7W	8M96D7W
		Channel Bandwidth 15MHz	13M4G7D	13M4D7W	13M4D7W
		Channel Bandwidth 20MHz	17M8G7D	17M9D7W	17M9D7W
	Antenna Type	Dipole antenna with 2dBi gain			
Antenna Connector	SMA Male				
Accessory Device	NA				
Cable Supplied	NA				

3.2 Configuration of System under Test

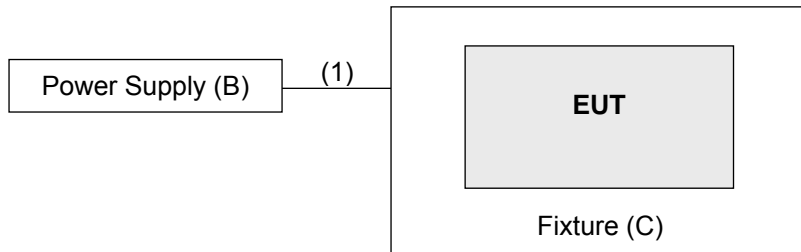

Remote site

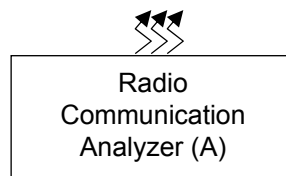

3.2.1 Description of Support Units

The EUT has been tested as an independent unit together with other necessary accessories or support units. The following support units or accessories were used to form a representative test configuration during the tests.

ID	Product	Brand	Model No.	Serial No.	FCC ID	Remarks
A.	Radio Communication Analyzer	Anritsu	MT8860C	1702001	NA	-
B.	DC power supply	Keysight	U8002A	MY56330015	NA	-
C.	Fixture	NA	NA	NA	NA	Provided by manufacturer

Note:

1. All power cords of the above support units are non-shielded (1.8m).
2. Item A acted as a communication partner to transfer data.

ID	Descriptions	Qty.	Length (m)	Shielding (Yes/No)	Cores (Qty.)	Remarks
1.	Power cable	1	2	N	0	-

3.3 Test Mode Applicability and Tested Channel Detail

Pre-Scan has been conducted to determine the worst-case mode from all possible combinations between available modulations, data rates, XYZ axis and antenna ports. The worst case was found when positioned on Z-plane. Following channel(s) was (were) selected for the final test as listed below.

WCDMA Band 4

EUT Configure Mode	Test Item	Available Channel	Tested Channel	Mode
-	EIRP	1312 to 1513	1312(1712.4MHz), 1413(1732.6MHz), 1513(1752.6MHz)	WCDMA
-	Modulation Characteristics	1312 to 1513	1413(1732.6MHz)	WCDMA, HSDPA, HSUPA
-	Frequency Stability	1312 to 1513	1312(1712.4MHz), 1513(1752.6MHz)	WCDMA
-	Occupied Bandwidth	1312 to 1513	1312(1712.4MHz), 1413(1732.6MHz), 1513(1752.6MHz)	WCDMA, HSDPA, HSUPA
-	Band Edge	1312 to 1513	1312(1712.4MHz), 1513(1752.6MHz)	WCDMA, HSDPA, HSUPA
-	Peak To Average Ratio	1312 to 1513	1312(1712.4MHz), 1413(1732.6MHz), 1513(1752.6MHz)	WCDMA, HSDPA, HSUPA
-	Conducted Emission	1312 to 1513	1312(1712.4MHz), 1413(1732.6MHz), 1513(1752.6MHz)	WCDMA, HSDPA, HSUPA
-	Radiated Emission Below 1GHz	1312 to 1513	1513(1752.6MHz)	WCDMA
-	Radiated Emission Above 1GHz	1312 to 1513	1312(1712.4MHz), 1413(1732.6MHz), 1513(1752.6MHz)	WCDMA

Note: For radiated emission below 1GHz, low, mid and high channels were pre-tested E.I.R.P. in chamber. High channel was found to be the worst case and therefore had been chosen for all final tests.

LTE Band 4

EUT Configure Mode	Test Item	Available Channel	Tested Channel	Channel Bandwidth	Modulation	Mode
-	EIRP	19957 to 20393	19957(1710.7MHz), 20175(1732.5MHz), 20393(1754.3MHz)	1.4MHz	QPSK / 16QAM / 64QAM	3 RB / 0 RB Offset
		19965 to 20385	19965(1711.5MHz), 20175(1732.5MHz), 20385(1753.5MHz)	3MHz	QPSK / 16QAM / 64QAM	1 RB / 0 RB Offset
		19975 to 20375	19975(1712.5MHz), 20175(1732.5MHz), 20375(1752.5MHz)	5MHz	QPSK / 16QAM / 64QAM	1 RB / 0 RB Offset
		20000 to 20350	20000(1715.0MHz), 20175(1732.5MHz), 20350(1750.0MHz)	10MHz	QPSK / 16QAM / 64QAM	1 RB / 0 RB Offset
		20025 to 20325	20025(1717.5MHz), 20175(1732.5MHz), 20325(1747.5MHz)	15MHz	QPSK / 16QAM / 64QAM	1 RB / 0 RB Offset
		20050 to 20300	20050(1720.0MHz), 20175(1732.5MHz), 20300(1745.0MHz)	20MHz	QPSK / 16QAM / 64QAM	1 RB / 0 RB Offset
-	Modulation Characteristics	20050 to 20300	20175(1732.5MHz)	20MHz	QPSK / 16QAM / 64QAM	100 RB / 0 RB Offset
-	Frequency Stability	19957 to 20393	19957(1710.7MHz), 20393(1754.3MHz)	1.4MHz	QPSK	3 RB / 0 RB Offset
		19965 to 20385	19965(1711.5MHz), 20385(1753.5MHz)	3MHz	QPSK	1 RB / 0 RB Offset
		19975 to 20375	19975(1712.5MHz), 20375(1752.5MHz)	5MHz	QPSK	1 RB / 0 RB Offset
		20000 to 20350	20000(1715.0MHz), 20350(1750.0MHz)	10MHz	QPSK	1 RB / 0 RB Offset
		20025 to 20325	20025(1717.5MHz), 20325(1747.5MHz)	15MHz	QPSK	1 RB / 0 RB Offset
		20050 to 20300	20050(1720.0MHz), 20300(1745.0MHz)	20MHz	QPSK	1 RB / 0 RB Offset
-	Emission Bandwidth	19957 to 20393	19957(1710.7MHz), 20175(1732.5MHz), 20393(1754.3MHz)	1.4MHz	QPSK / 16QAM / 64QAM	6 RB / 0RB Offset
		19965 to 20385	19965(1711.5MHz), 20175(1732.5MHz), 20385(1753.5MHz)	3MHz	QPSK / 16QAM / 64QAM	15 RB / 0RB Offset
		19975 to 20375	19975(1712.5MHz), 20175(1732.5MHz), 20375(1752.5MHz)	5MHz	QPSK / 16QAM / 64QAM	25RB / 0RB Offset
		20000 to 20350	20000(1715.0MHz), 20175(1732.5MHz), 20350(1750.0MHz)	10MHz	QPSK / 16QAM / 64QAM	50RB / 0RB Offset
		20025 to 20325	20025(1717.5MHz), 20175(1732.5MHz), 20325(1747.5MHz)	15MHz	QPSK / 16QAM / 64QAM	75 RB / 0 RB Offset
		20050 to 20300	20050(1720.0MHz), 20175(1732.5MHz), 20300(1745.0MHz)	20MHz	QPSK / 16QAM / 64QAM	100 RB / 0 RB Offset

EUT Configure Mode	Test Item	Available Channel	Tested Channel	Channel Bandwidth	Modulation	Mode
-	Band Edge	19957 to 20393	19957(1710.7MHz), 20393(1754.3MHz)	1.4MHz	QPSK	1 RB / 0 RB Offset 1 RB / 5 RB Offset 6 RB / 0 RB Offset
		19965 to 20385	19965(1711.5MHz), 20385(1753.5MHz)	3MHz	QPSK	1 RB / 0 RB Offset 1 RB / 14 RB Offset 15 RB / 0 RB Offset
		19975 to 20375	19975(1712.5MHz), 20375(1752.5MHz)	5MHz	QPSK	1 RB / 0 RB Offset 1 RB / 24 RB Offset 25 RB / 0 RB Offset
		20000 to 20350	20000(1715.0MHz), 20350(1750.0MHz)	10MHz	QPSK	1 RB / 0 RB Offset 1 RB / 49 RB Offset 50 RB / 0 RB Offset
		20025 to 20325	20025(1717.5MHz), 20325(1747.5MHz)	15MHz	QPSK	1 RB / 0 RB Offset 1 RB / 74 RB Offset 75 RB / 0 RB Offset
		20050 to 20300	20050(1720.0MHz), 20300(1745.0MHz)	20MHz	QPSK	1 RB / 0 RB Offset 1 RB / 99 RB Offset 100 RB / 0 RB Offset
-	Peak To Average Ratio	19957 to 20393	19957(1710.7MHz), 20175(1732.5MHz), 20393(1754.3MHz)	1.4MHz	QPSK / 16QAM / 64QAM	3 RB / 0 RB Offset
		19965 to 20385	19965(1711.5MHz), 20175(1732.5MHz), 20385(1753.5MHz)	3MHz	QPSK / 16QAM / 64QAM	1 RB / 0 RB Offset
		19975 to 20375	19975(1712.5MHz), 20175(1732.5MHz), 20375(1752.5MHz)	5MHz	QPSK / 16QAM / 64QAM	1 RB / 0 RB Offset
		20000 to 20350	20000(1715.0MHz), 20175(1732.5MHz), 20350(1750.0MHz)	10MHz	QPSK / 16QAM / 64QAM	1 RB / 0 RB Offset
		20025 to 20325	20025(1717.5MHz), 20175(1732.5MHz), 20325(1747.5MHz)	15MHz	QPSK / 16QAM / 64QAM	1 RB / 0 RB Offset
		20050 to 20300	20050(1720.0MHz), 20175(1732.5MHz), 20300(1745.0MHz)	20MHz	QPSK / 16QAM / 64QAM	1 RB / 0 RB Offset
-	Conducted Emission	19957 to 20393	19957(1710.7MHz), 20175(1732.5MHz), 20393(1754.3MHz)	1.4MHz	QPSK	3 RB / 0 RB Offset
		19965 to 20385	19965(1711.5MHz), 20175(1732.5MHz), 20385(1753.5MHz)	3MHz	QPSK	1 RB / 0 RB Offset
		19975 to 20375	19975(1712.5MHz), 20175(1732.5MHz), 20375(1752.5MHz)	5MHz	QPSK	1 RB / 0 RB Offset
		20000 to 20350	20000(1715.0MHz), 20175(1732.5MHz), 20350(1750.0MHz)	10MHz	QPSK	1 RB / 0 RB Offset
		20025 to 20325	20025(1717.5MHz), 20175(1732.5MHz), 20325(1747.5MHz)	15MHz	QPSK	1 RB / 0 RB Offset
		20050 to 20300	20050(1720.0MHz), 20175(1732.5MHz), 20300(1745.0MHz)	20MHz	QPSK	1 RB / 0 RB Offset

EUT Configure Mode	Test Item	Available Channel	Tested Channel	Channel Bandwidth	Modulation	Mode
-	Radiated Emission Below 1GHz	19957 to 20393	19957(1710.7MHz)	1.4MHz	QPSK	3 RB / 0 RB Offset
		19975 to 20375	19975(1712.5MHz)	5MHz	QPSK	1 RB / 0 RB Offset
		20050 to 20300	20050(1720.0MHz)	20MHz	QPSK	1 RB / 0 RB Offset
-	Radiated Emission Above 1GHz	19957 to 20393	19957(1710.7MHz), 20175(1732.5MHz), 20393(1754.3MHz)	1.4MHz	QPSK	3 RB / 0 RB Offset
		19975 to 20375	19975(1712.5MHz), 20175(1732.5MHz), 20375(1752.5MHz)	5MHz	QPSK	1 RB / 0 RB Offset
		20050 to 20300	20050(1720.0MHz), 20175(1732.5MHz), 20300(1745.0MHz)	20MHz	QPSK	1 RB / 0 RB Offset

Note:

1. For radiated emission below 1GHz, low, mid and high channels were pre-tested in chamber with 1.4MHz mode. Low channel was found to be the worst case and therefore had been chosen for all final tests.
2. For radiated emission above 1GHz, according to 3GPP 36.521 Section 6.6.3.1.4, choose the lowest, 5MHz & highest channel bandwidth for final test.
3. The conducted output power for QPSK, 16QAM and 64QAM, measured value of QPSK is higher than 16QAM and 64QAM mode. Therefore, only Modulation characteristics, occupied bandwidth and Peak to average ratio items had been tested under QPSK, 16QAM and 64QAM modes, the other test items were performed under QPSK mode only.

LTE Band 7

EUT Configure Mode	Test Item	Available Channel	Tested Channel	Channel Bandwidth	Modulation	Mode
-	EIRP	2775 to 3425	20775(2502.5MHz), 21100(2535.0MHz), 21425(2567.5MHz)	5MHz	QPSK / 16QAM / 64QAM	1 RB / 24 RB Offset
		2800 to 3400	20800(2505.0MHz), 21100(2535.0MHz), 21400(2565.0MHz),	10MHz	QPSK / 16QAM / 64QAM	1 RB / 49 RB Offset
		2825 to 3375	20825(2507.5MHz), 21100(2535.0MHz), 21375(2562.5MHz)	15MHz	QPSK / 16QAM / 64QAM	1 RB / 74 RB Offset
		2850 to 3350	20850(2510.0MHz), 21100(2535.0MHz), 21350(2560.0MHz)	20MHz	QPSK / 16QAM / 64QAM	1 RB / 99 RB Offset
-	Modulation Characteristics	2850 to 3350	21100(2535.0MHz)	20MHz	QPSK / 16QAM / 64QAM	100 RB / 0 RB Offset
-	Frequency Stability	2775 to 3425	20775(2502.5MHz), 21425(2567.5MHz)	5MHz	QPSK	1 RB / 24 RB Offset
		2800 to 3400	20800(2505.0MHz), 21400(2565.0MHz),	10MHz	QPSK	1 RB / 49 RB Offset
		2825 to 3375	20825(2507.5MHz), 21375(2562.5MHz)	15MHz	QPSK	1 RB / 74 RB Offset
		2850 to 3350	20850(2510.0MHz), 21350(2560.0MHz)	20MHz	QPSK	1 RB / 99 RB Offset
-	Emission Bandwidth	2775 to 3425	20775(2502.5MHz), 21100(2535.0MHz), 21425(2567.5MHz)	5MHz	QPSK / 16QAM / 64QAM	25RB / 0RB Offset
		2800 to 3400	20800(2505.0MHz), 21100(2535.0MHz), 21400(2565.0MHz),	10MHz	QPSK / 16QAM / 64QAM	50RB / 0RB Offset
		2825 to 3375	20825(2507.5MHz), 21100(2535.0MHz), 21375(2562.5MHz)	15MHz	QPSK / 16QAM / 64QAM	75 RB / 0 RB Offset
		2850 to 3350	20850(2510.0MHz), 21100(2535.0MHz), 21350(2560.0MHz)	20MHz	QPSK / 16QAM / 64QAM	100 RB / 0 RB Offset
-	Band Edge	2775 to 3425	20775(2502.5MHz), 21425(2567.5MHz)	5MHz	QPSK	1 RB / 0 RB Offset 1 RB / 24 RB Offset 25 RB / 0 RB Offset
		2800 to 3400	20800(2505.0MHz), 21400(2565.0MHz),	10MHz	QPSK	1 RB / 0 RB Offset 1 RB / 49 RB Offset 50 RB / 0 RB Offset
		2825 to 3375	20825(2507.5MHz), 21375(2562.5MHz)	15MHz	QPSK	1 RB / 0 RB Offset 1 RB / 74 RB Offset 75 RB / 0 RB Offset
		2850 to 3350	20850(2510.0MHz), 21350(2560.0MHz)	20MHz	QPSK	1 RB / 0 RB Offset 1 RB / 99 RB Offset 100 RB / 0 RB Offset
-	Peak To Average Ratio	2775 to 3425	20775(2502.5MHz), 21100(2535.0MHz), 21425(2567.5MHz)	5MHz	QPSK / 16QAM / 64QAM	1 RB / 24 RB Offset
		2800 to 3400	20800(2505.0MHz), 21100(2535.0MHz), 21400(2565.0MHz),	10MHz	QPSK / 16QAM / 64QAM	1 RB / 49 RB Offset
		2825 to 3375	20825(2507.5MHz), 21100(2535.0MHz), 21375(2562.5MHz)	15MHz	QPSK / 16QAM / 64QAM	1 RB / 74 RB Offset
		2850 to 3350	20850(2510.0MHz), 21100(2535.0MHz), 21350(2560.0MHz)	20MHz	QPSK / 16QAM / 64QAM	1 RB / 99 RB Offset

EUT Configure Mode	Test Item	Available Channel	Tested Channel	Channel Bandwidth	Modulation	Mode
-	Conducted Emission	2775 to 3425	20775(2502.5MHz), 21100(2535.0MHz), 21425(2567.5MHz)	5MHz	QPSK	1 RB / 24 RB Offset
		2800 to 3400	20800(2505.0MHz), 21100(2535.0MHz), 21400(2565.0MHz),	10MHz	QPSK	1 RB / 49 RB Offset
		2825 to 3375	20825(2507.5MHz), 21100(2535.0MHz), 21375(2562.5MHz)	15MHz	QPSK	1 RB / 74 RB Offset
		2850 to 3350	20850(2510.0MHz), 21100(2535.0MHz), 21350(2560.0MHz)	20MHz	QPSK	1 RB / 99 RB Offset
-	Radiated Emission Below 1GHz	2775 to 3425	20775(2502.5MHz)	5MHz	QPSK	1 RB / 24 RB Offset
		2850 to 3350	20850(2510.0MHz)	20MHz	QPSK	1 RB / 99 RB Offset
-	Radiated Emission Above 1GHz	2775 to 3425	20775(2502.5MHz), 21100(2535.0MHz), 21425(2567.5MHz)	5MHz	QPSK	1 RB / 24 RB Offset
		2850 to 3350	20850(2510.0MHz), 21100(2535.0MHz), 21350(2560.0MHz)	20MHz	QPSK	1 RB / 99 RB Offset

Note:

1. For radiated emission below 1GHz, low, mid and high channels were pre-tested in chamber with 5MHz mode. Low channel was found to be the worst case and therefore had been chosen for all final tests.
2. For radiated emission above 1GHz, according to 3GPP 36.521 Section 6.6.3.1.4, choose the 5MHz & highest channel bandwidth for final test.
3. The conducted output power for QPSK, 16QAM and 64QAM, measured value of QPSK is higher than 16QAM and 64QAM mode. Therefore, only Modulation characteristics, occupied bandwidth and Peak to average ratio items had been tested under QPSK, 16QAM and 64QAM modes, the other test items were performed under QPSK mode only.

Test Condition:

Test Item	Environmental Conditions	Input Power	Tested By
EIRP	25deg. C, 70%RH	120Vac, 60Hz	Han Wu
Modulation characteristics	24deg. C, 64%RH	120Vac, 60Hz	James Yang
Frequency Stability	24deg. C, 64%RH	120Vac, 60Hz	James Yang
Occupied Bandwidth	24deg. C, 64%RH	120Vac, 60Hz	James Yang
Band Edge	24deg. C, 64%RH	120Vac, 60Hz	James Yang
Peak To Average Ratio	24deg. C, 64%RH	120Vac, 60Hz	James Yang
Conducted Emission	24deg. C, 64%RH	120Vac, 60Hz	James Yang
Radiated Emission	25deg. C, 70%RH	120Vac, 60Hz	Noah Chang

3.4 EUT Operating Conditions

The EUT makes a call to the communication simulator. The communication simulator station system controlled a EUT to export maximum output power under transmission mode and specific channel frequency

3.5 General Description of Applied Standards

The EUT is a RF Product. According to the specifications of the manufacturer, it must comply with the requirements of the following standards:

FCC 47 CFR Part 2

FCC 47 CFR Part 27

KDB 971168 D01 Power Meas License Digital Systems v03r01

ANSI/TIA/EIA-603-E 2016

ANSI 63.26-2015

Note: All test items have been performed and recorded as per the above standards.

4 Test Types and Results

4.1 Output Power Measurement

4.1.1 Limits of Output Power Measurement

Mobile / Portable station are limited to 1 watts e.i.r.p for WCDMA, LTE Band 4; 2 watts e.i.r.p. for LTE Band 7.

4.1.2 Test Procedures

EIRP / ERP Measurement:

- a. All measurements were done at low, middle and high operational frequency range. RBW and VBW is 5MHz for WCDMA mode, 10MHz for LTE mode.
- b. Substitution method is used for E.I.R.P measurement. In the semi-anechoic chamber, EUT placed on the 0.8m(below or equal 1GHz) and/or 1.5m(above 1GHz) height of Turn Table, rotated the table around 360 degrees to search the maximum radiation power and receiver antenna shall be rotated vertical and horizontal polarization and moved height from 1m to 4m to find the maximum polar radiated power. The "Read Value" is the spectrum reading the maximum power value.
- c. The substitution horn antenna is substituted for EUT at the same position and signals generator export the CW signal to the substitution antenna via a TX cable. Rotated the Turn Table and moved receiving antenna to find the maximum radiation power. Adjust output power level of S.G to get a Value of spectrum reading equal to "Read Value" of step b. Record the power level of S.G
- d. $EIRP = \text{Output power level of S.G} - \text{TX cable loss} + \text{Antenna gain of substitution horn}$. E.R.P power can be calculated form E.I.R.P power by subtracting the gain of dipole, $E.R.P \text{ power} = E.I.R.P \text{ power} - 2.15\text{dBi}$.

Where:

$$ERP/EIRP = P_{Meas} + G_T - L_C$$

P_{Meas} : Measure transmitter output power.

G_T : Gain of the transmitting antenna.

L_C : signal attenuation in the connecting cable between the transmitter and antenna.

Conducted Power Measurement:

The EUT was set up for the maximum power with GSM, WCDMA, LTE link data modulation and link up with simulator. Set the EUT to transmit under low, middle and high channel and record the power level shown on simulator.

4.1.3 Test Setup

EIRP / ERP Measurement:

For radiated emission 30MHz to 1GHz

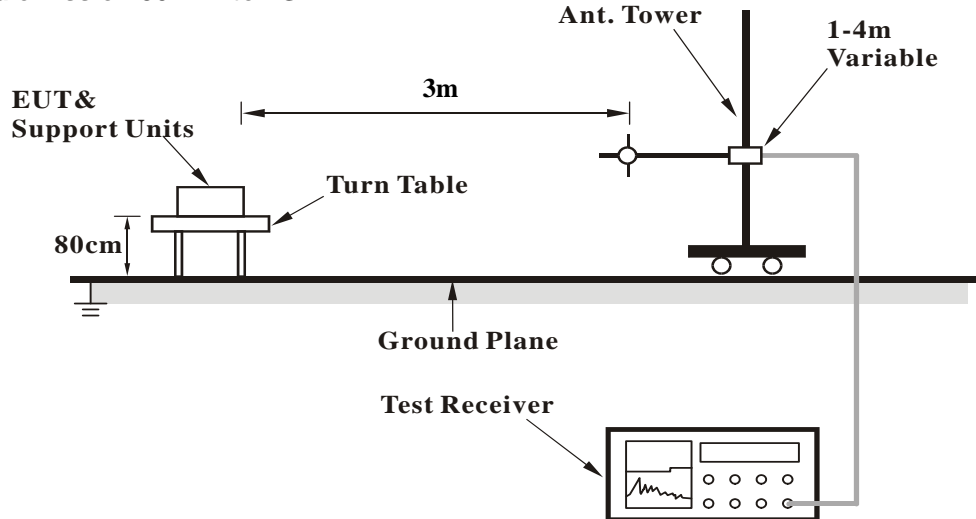

For radiated emission above 1GHz

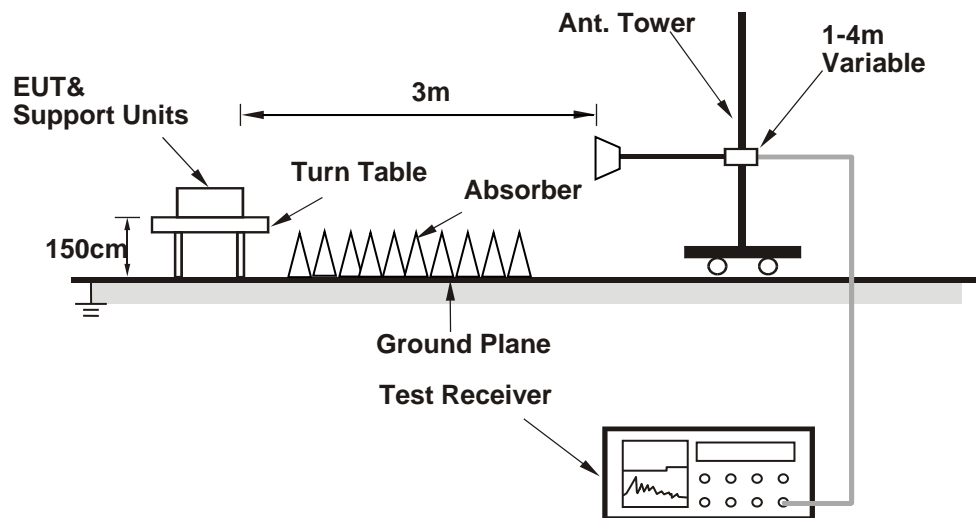

For the actual test configuration, please refer to the attached file (Test Setup Photo).

Conducted Power Measurement:



For the actual test configuration, please refer to the attached file (Test Setup Photo).

4.1.4 Test Results

Conducted Output Power (dBm)

Band	WCDMA IV		
	1312	1413	1513
TX Channel	1312	1413	1513
Rx Channel	1537	1638	1738
Frequency	1712.4	1732.6	1752.6
RMC 12.2K	23.81	23.75	23.78
HSDPA Subtest-1	23.11	23.06	23.05
HSDPA Subtest-2	23.05	23.01	22.98
HSDPA Subtest-3	22.40	22.32	22.35
HSDPA Subtest-4	22.32	22.22	22.26
HSUPA Subtest-1	23.06	23.02	23.08
HSUPA Subtest-2	20.76	20.70	20.73
HSUPA Subtest-3	21.81	21.73	21.77
HSUPA Subtest-4	20.69	20.61	20.65
HSUPA Subtest-5	22.89	22.80	22.84

LTE Band 4							
BW	MCS Index	RB Size	RB Offset	Low	Mid	High	3GPP MPR (dB)
		Channel		19957	20175	20393	
		Frequency (MHz)		1710.7	1732.5	1754.3	
1.4M	QPSK	1	0	23.58	23.49	23.62	0
		1	2	23.52	23.47	23.60	0
		1	5	23.55	23.44	23.59	0
		3	0	23.21	23.18	23.24	0
		3	1	23.18	23.22	23.23	0
		3	3	23.19	23.15	23.18	0
	16QAM	6	0	22.96	22.97	22.99	1
		1	0	22.51	22.46	22.92	1
		1	2	22.48	22.44	22.90	1
		1	5	22.46	22.45	22.89	1
		3	0	22.06	22.01	22.18	1
		3	1	22.18	22.10	22.27	1
	64QAM	3	3	22.16	22.08	22.24	1
		6	0	22.01	21.99	22.06	2
		1	0	22.32	22.35	22.39	1
		1	2	22.28	22.28	22.44	1
		1	5	22.34	22.33	22.31	1
		3	0	22.06	22.10	22.06	1
		3	1	22.08	22.06	22.08	1
	3	3	22.01	22.05	22.06	1	
	6	0	21.87	21.89	21.85	2	

LTE Band 4							
BW	MCS Index	RB Size	RB Offset	Low	Mid	High	3GPP MPR (dB)
		Channel		19965	20175	20385	
		Frequency (MHz)		1711.5	1732.5	1753.5	
3M	QPSK	1	0	23.44	23.62	23.45	0
		1	7	23.41	23.58	23.44	0
		1	14	23.38	23.61	23.40	0
		8	0	23.11	23.15	23.06	1
		8	3	23.15	23.18	23.08	1
		8	7	23.08	23.11	23.15	1
		15	0	22.95	22.99	22.97	1
	16QAM	1	0	22.98	23.06	22.76	1
		1	7	22.96	23.01	22.71	1
		1	14	22.96	23.02	22.71	1
		8	0	22.75	22.86	22.65	2
		8	3	22.71	22.81	22.68	2
		8	7	22.74	22.82	22.61	2
		15	0	22.62	22.67	22.49	2
	64QAM	1	0	22.89	22.91	22.84	1
		1	7	22.81	22.88	22.81	1
		1	14	22.83	22.86	22.76	1
		8	0	22.59	22.54	22.51	2
		8	3	22.54	22.54	22.52	2
		8	7	22.58	22.51	22.54	2
		15	0	22.38	22.31	22.28	2

LTE Band 4							
BW	MCS Index	RB Size	RB Offset	Low	Mid	High	3GPP MPR (dB)
		Channel		19975	20175	20375	
		Frequency (MHz)		1712.5	1732.5	1752.5	
5M	QPSK	1	0	23.55	23.48	23.33	0
		1	12	23.48	23.44	23.22	0
		1	24	23.51	23.46	23.29	0
		12	0	23.26	23.19	23.16	1
		12	6	23.22	23.22	23.19	1
		12	13	23.25	23.24	23.20	1
		25	0	23.11	23.08	23.11	1
	16QAM	1	0	22.78	22.63	22.47	1
		1	12	22.71	22.61	22.41	1
		1	24	22.73	22.57	22.44	1
		12	0	22.52	22.48	22.32	2
		12	6	22.48	22.42	22.26	2
		12	13	22.44	22.46	22.19	2
		25	0	22.36	22.33	22.26	2
	64QAM	1	0	22.61	22.49	22.52	1
		1	12	22.56	22.41	22.55	1
		1	24	22.49	22.46	22.51	1
		12	0	22.21	22.09	22.12	2
		12	6	22.26	22.11	22.09	2
		12	13	22.22	22.18	22.08	2
		25	0	22.04	22.03	22.04	2

LTE Band 4							
BW	MCS Index	RB Size	RB Offset	Low	Mid	High	3GPP MPR (dB)
		Channel		20000	20175	20350	
		Frequency (MHz)		1715	1732.5	1750	
10M	QPSK	1	0	23.58	23.55	23.53	0
		1	24	23.52	23.51	23.49	0
		1	49	23.54	23.51	23.49	0
		25	0	23.33	23.33	23.52	1
		25	12	23.32	23.29	23.18	1
		25	25	23.34	23.31	23.23	1
		50	0	23.26	23.22	23.18	1
	16QAM	1	0	22.57	22.48	22.39	1
		1	24	22.52	22.40	22.39	1
		1	49	22.54	22.45	22.38	1
		25	0	22.31	22.29	22.26	2
		25	12	22.36	22.26	22.22	2
		25	25	22.33	22.30	22.26	2
		50	0	22.24	22.22	22.17	2
	64QAM	1	0	22.39	22.31	22.33	1
		1	24	22.31	22.36	22.29	1
		1	49	22.34	22.28	22.28	1
		25	0	22.28	22.19	22.21	2
		25	12	22.26	22.23	22.16	2
		25	25	22.24	22.20	22.19	2
		50	0	22.17	22.14	22.11	2

LTE Band 4							
BW	MCS Index	RB Size	RB Offset	Low	Mid	High	3GPP MPR (dB)
		Channel		20025	20175	20325	
		Frequency (MHz)		1717.5	1732.5	1747.5	
15M	QPSK	1	0	23.66	23.48	23.62	0
		1	37	23.61	23.44	23.61	0
		1	74	23.64	23.46	23.57	0
		36	0	23.38	23.31	23.28	1
		36	19	23.41	23.33	23.33	1
		36	39	23.36	23.29	23.31	1
		75	0	23.25	23.22	23.23	1
	16QAM	1	0	22.50	22.41	22.47	1
		1	37	22.44	22.38	22.44	1
		1	74	22.46	22.39	22.47	1
		36	0	22.21	22.19	22.11	2
		36	19	22.25	22.20	22.22	2
		36	39	22.23	22.19	22.19	2
		75	0	22.08	22.07	22.08	2
	64QAM	1	0	22.38	22.29	22.33	1
		1	37	23.33	22.26	22.28	1
		1	74	23.34	22.21	22.30	1
		36	0	23.19	22.15	22.11	2
		36	19	23.20	22.19	22.16	2
		36	39	23.16	22.16	22.15	2
		75	0	23.02	22.06	22.01	2

LTE Band 4							
BW	MCS Index	RB Size	RB Offset	Low	Mid	High	3GPP MPR (dB)
		Channel		20050	20175	20300	
		Frequency (MHz)		1720	1732.5	1745	
20M	QPSK	1	0	23.58	23.63	23.75	0
		1	50	23.55	23.58	23.68	0
		1	99	23.51	23.55	23.66	0
		50	0	23.44	23.45	23.53	1
		50	25	23.39	23.40	23.55	1
		50	50	23.36	23.42	23.49	1
		100	0	23.21	23.29	23.37	1
	16QAM	1	0	22.45	22.56	22.59	1
		1	50	22.43	22.52	22.55	1
		1	99	22.43	22.55	22.53	1
		50	0	22.26	22.19	22.26	2
		50	25	22.21	22.18	22.21	2
		50	50	22.25	22.26	22.22	2
		100	0	22.06	22.06	22.11	2
	64QAM	1	0	22.24	22.29	22.35	1
		1	50	22.18	22.24	22.28	1
		1	99	22.20	22.23	22.26	1
		50	0	22.03	22.09	22.06	2
		50	25	22.08	22.08	22.15	2
		50	50	22.03	22.10	22.13	2
		100	0	21.88	21.94	21.99	2

LTE Band 7							
BW	MCS Index	RB Size	RB Offset	Low	Mid	High	3GPP MPR (dB)
		Channel		20775	21100	21425	
		Frequency (MHz)		2502.5	2535	2567.5	
5M	QPSK	1	0	23.66	23.58	23.62	0
		1	12	23.61	23.51	23.58	0
		1	24	23.58	23.52	23.59	0
		12	0	23.22	23.16	23.20	1
		12	6	23.26	23.20	23.21	1
		12	13	23.25	23.22	23.15	1
		25	0	23.05	23.01	23.04	1
	16QAM	1	0	22.31	22.26	22.28	1
		1	12	22.26	22.16	22.21	1
		1	24	22.24	22.19	22.28	1
		12	0	22.08	22.02	22.06	2
		12	6	22.06	22.03	22.00	2
		12	13	22.08	22.04	22.06	2
		25	0	21.91	21.93	21.88	2
	64QAM	1	0	22.16	22.05	22.03	1
		1	12	22.11	22.03	22.06	1
		1	24	22.14	22.08	22.09	1
		12	0	21.99	21.95	21.91	2
		12	6	21.95	21.92	21.91	2
		12	13	21.92	21.94	21.92	2
		25	0	21.67	21.63	21.57	2

LTE Band 7							
BW	MCS Index	RB Size	RB Offset	Low	Mid	High	3GPP MPR (dB)
		Channel		20800	21100	21400	
		Frequency (MHz)		2505	2535	2565	
10M	QPSK	1	0	23.32	23.53	23.48	0
		1	24	23.21	23.51	23.41	0
		1	49	23.21	23.44	23.44	0
		25	0	23.06	23.20	23.16	1
		25	12	23.05	23.18	23.11	1
		25	25	23.08	23.11	23.05	1
		50	0	22.86	22.99	22.94	1
	16QAM	1	0	22.44	22.48	22.41	1
		1	24	22.41	22.43	22.38	1
		1	49	22.43	22.46	22.34	1
		25	0	22.16	22.28	22.16	2
		25	12	22.15	22.21	22.18	2
		25	25	22.16	22.20	22.12	2
		50	0	22.01	22.16	22.06	2
	64QAM	1	0	22.28	22.34	22.32	1
		1	24	22.22	22.30	22.26	1
		1	49	22.26	22.28	22.22	1
		25	0	22.03	22.06	22.03	2
		25	12	22.04	22.08	22.05	2
		25	25	22.01	22.01	22.04	2
		50	0	21.88	21.92	21.85	2

LTE Band 7							
BW	MCS Index	RB Size	RB Offset	Low	Mid	High	3GPP MPR (dB)
		Channel		20825	21100	21375	
		Frequency (MHz)		2507.5	2535	2562.5	
15M	QPSK	1	0	23.62	23.66	23.57	0
		1	37	23.55	23.62	23.55	0
		1	74	23.58	23.61	23.52	0
		36	0	23.26	23.28	23.18	1
		36	19	23.22	23.22	23.10	1
		36	39	23.28	23.29	23.23	1
		75	0	23.03	23.06	23.00	1
	16QAM	1	0	22.43	22.49	22.44	1
		1	37	22.38	22.44	22.41	1
		1	74	22.35	22.43	22.40	1
		36	0	22.16	22.23	22.16	2
		36	19	22.08	22.09	22.20	2
		36	39	22.09	22.18	22.18	2
		75	0	21.85	21.96	21.88	2
	64QAM	1	0	22.26	22.31	22.29	1
		1	37	22.22	22.25	22.09	1
		1	74	22.18	22.25	22.18	1
		36	0	22.02	22.10	22.06	2
		36	19	22.01	22.12	22.10	2
		36	39	21.97	22.08	22.06	2
		75	0	21.62	21.74	21.62	2

LTE Band 7							
BW	MCS Index	RB Size	RB Offset	Low	Mid	High	3GPP MPR (dB)
		Channel		20850	21100	21350	
		Frequency (MHz)		2510	2535	2560	
20M	QPSK	1	0	23.53	23.62	23.47	0
		1	50	22.51	23.58	23.44	0
		1	99	22.55	23.59	23.41	0
		50	0	22.32	22.40	22.28	1
		50	25	22.26	22.38	22.25	1
		50	50	22.28	22.33	22.26	1
		100	0	22.11	22.26	22.06	1
	16QAM	1	0	22.38	22.49	22.33	1
		1	50	22.33	22.41	22.24	1
		1	99	22.30	22.44	22.21	1
		50	0	22.12	22.25	22.16	2
		50	25	22.16	22.23	22.15	2
		50	50	22.08	22.26	22.13	2
		100	0	21.92	21.98	21.86	2
	64QAM	1	0	22.21	22.32	22.28	1
		1	50	22.18	22.26	22.21	1
		1	99	22.15	22.22	22.22	1
		50	0	22.02	22.16	22.06	2
		50	25	22.01	22.11	22.02	2
		50	50	22.04	22.14	22.03	2
		100	0	21.73	21.87	21.71	2

EIRP Power

WCDMA Band 4 Mode

Mode		TX channel 1312					
Antenna Polarity & Test Distance: Horizontal at 3 M							
No.	Freq. (MHz)	Reading (dBm)	S.G Power Value (dBm)	Correction Factor (dB)	EIRP (dBm)	Limit (dBm)	Margin (dB)
1	1712.40	-16.9	21.1	0.7	21.8	30.0	-8.2
Antenna Polarity & Test Distance: Vertical at 3 M							
No.	Freq. (MHz)	Reading (dBm)	S.G Power Value (dBm)	Correction Factor (dB)	EIRP (dBm)	Limit (dBm)	Margin (dB)
1	1712.40	-12.6	25.2	0.7	25.9	30.0	-4.1

Mode		TX channel 1413					
Antenna Polarity & Test Distance: Horizontal at 3 M							
No.	Freq. (MHz)	Reading (dBm)	S.G Power Value (dBm)	Correction Factor (dB)	EIRP (dBm)	Limit (dBm)	Margin (dB)
1	1732.60	-17.3	21.1	0.6	21.7	30.0	-8.3
Antenna Polarity & Test Distance: Vertical at 3 M							
No.	Freq. (MHz)	Reading (dBm)	S.G Power Value (dBm)	Correction Factor (dB)	EIRP (dBm)	Limit (dBm)	Margin (dB)
1	1732.60	-12.9	25.5	0.6	26.1	30.0	-3.9

Mode		TX channel 1513					
Antenna Polarity & Test Distance: Horizontal at 3 M							
No.	Freq. (MHz)	Reading (dBm)	S.G Power Value (dBm)	Correction Factor (dB)	EIRP (dBm)	Limit (dBm)	Margin (dB)
1	1752.60	-17.0	21.8	0.5	22.3	30.0	-7.7
Antenna Polarity & Test Distance: Vertical at 3 M							
No.	Freq. (MHz)	Reading (dBm)	S.G Power Value (dBm)	Correction Factor (dB)	EIRP (dBm)	Limit (dBm)	Margin (dB)
1	1752.60	-12.5	26.3	0.5	26.8	30.0	-3.2

Note: EIRP (dBm) = S.G Power Value (dBm) + Correction Factor (dB).

Modulation Type: QPSK

LTE Band 4, Channel Bandwidth: 1.4MHz

Mode		TX channel 19957					
Antenna Polarity & Test Distance: Horizontal at 3 M							
No.	Freq. (MHz)	Reading (dBm)	S.G Power Value (dBm)	Correction Factor (dB)	EIRP (dBm)	Limit (dBm)	Margin (dB)
1	1710.70	-18.9	19.1	0.7	19.8	30.0	-10.2
Antenna Polarity & Test Distance: Vertical at 3 M							
No.	Freq. (MHz)	Reading (dBm)	S.G Power Value (dBm)	Correction Factor (dB)	EIRP (dBm)	Limit (dBm)	Margin (dB)
1	1710.70	-13.2	24.6	0.7	25.3	30.0	-4.7

Mode		TX channel 20175					
Antenna Polarity & Test Distance: Horizontal at 3 M							
No.	Freq. (MHz)	Reading (dBm)	S.G Power Value (dBm)	Correction Factor (dB)	EIRP (dBm)	Limit (dBm)	Margin (dB)
1	1732.50	-18.8	19.6	0.6	20.2	30.0	-9.8
Antenna Polarity & Test Distance: Vertical at 3 M							
No.	Freq. (MHz)	Reading (dBm)	S.G Power Value (dBm)	Correction Factor (dB)	EIRP (dBm)	Limit (dBm)	Margin (dB)
1	1732.50	-13.6	24.7	0.6	25.3	30.0	-4.7

Mode		TX channel 20393					
Antenna Polarity & Test Distance: Horizontal at 3 M							
No.	Freq. (MHz)	Reading (dBm)	S.G Power Value (dBm)	Correction Factor (dB)	EIRP (dBm)	Limit (dBm)	Margin (dB)
1	1754.30	-18.7	20.1	0.5	20.6	30.0	-9.4
Antenna Polarity & Test Distance: Vertical at 3 M							
No.	Freq. (MHz)	Reading (dBm)	S.G Power Value (dBm)	Correction Factor (dB)	EIRP (dBm)	Limit (dBm)	Margin (dB)
1	1754.30	-13.1	25.8	0.5	26.3	30.0	-3.7

Note: EIRP (dBm) = S.G Power Value (dBm) + Correction Factor (dB).

LTE Band 4, Channel Bandwidth: 3MHz

Mode		TX channel 19965					
Antenna Polarity & Test Distance: Horizontal at 3 M							
No.	Freq. (MHz)	Reading (dBm)	S.G Power Value (dBm)	Correction Factor (dB)	EIRP (dBm)	Limit (dBm)	Margin (dB)
1	1711.50	-18.4	19.6	0.7	20.3	30.0	-9.7
Antenna Polarity & Test Distance: Vertical at 3 M							
No.	Freq. (MHz)	Reading (dBm)	S.G Power Value (dBm)	Correction Factor (dB)	EIRP (dBm)	Limit (dBm)	Margin (dB)
1	1711.50	-13.5	24.3	0.7	25.0	30.0	-5.0

Mode		TX channel 20175					
Antenna Polarity & Test Distance: Horizontal at 3 M							
No.	Freq. (MHz)	Reading (dBm)	S.G Power Value (dBm)	Correction Factor (dB)	EIRP (dBm)	Limit (dBm)	Margin (dB)
1	1732.50	-18.5	19.9	0.6	20.5	30.0	-9.5
Antenna Polarity & Test Distance: Vertical at 3 M							
No.	Freq. (MHz)	Reading (dBm)	S.G Power Value (dBm)	Correction Factor (dB)	EIRP (dBm)	Limit (dBm)	Margin (dB)
1	1732.50	-13.7	24.6	0.6	25.2	30.0	-4.8

Mode		TX channel 20385					
Antenna Polarity & Test Distance: Horizontal at 3 M							
No.	Freq. (MHz)	Reading (dBm)	S.G Power Value (dBm)	Correction Factor (dB)	EIRP (dBm)	Limit (dBm)	Margin (dB)
1	1753.50	-18.2	20.6	0.5	21.1	30.0	-8.9
Antenna Polarity & Test Distance: Vertical at 3 M							
No.	Freq. (MHz)	Reading (dBm)	S.G Power Value (dBm)	Correction Factor (dB)	EIRP (dBm)	Limit (dBm)	Margin (dB)
1	1753.50	-13.9	25.0	0.5	25.5	30.0	-4.5

Note: EIRP (dBm) = S.G Power Value (dBm) + Correction Factor (dB).

LTE Band 4, Channel Bandwidth: 5MHz

Mode		TX channel 19975					
Antenna Polarity & Test Distance: Horizontal at 3 M							
No.	Freq. (MHz)	Reading (dBm)	S.G Power Value (dBm)	Correction Factor (dB)	EIRP (dBm)	Limit (dBm)	Margin (dB)
1	1712.50	-18.5	19.6	0.7	20.3	30.0	-9.7
Antenna Polarity & Test Distance: Vertical at 3 M							
No.	Freq. (MHz)	Reading (dBm)	S.G Power Value (dBm)	Correction Factor (dB)	EIRP (dBm)	Limit (dBm)	Margin (dB)
1	1712.50	-13.5	24.4	0.7	25.1	30.0	-4.9

Mode		TX channel 20175					
Antenna Polarity & Test Distance: Horizontal at 3 M							
No.	Freq. (MHz)	Reading (dBm)	S.G Power Value (dBm)	Correction Factor (dB)	EIRP (dBm)	Limit (dBm)	Margin (dB)
1	1732.50	-18.3	20.1	0.6	20.7	30.0	-9.3
Antenna Polarity & Test Distance: Vertical at 3 M							
No.	Freq. (MHz)	Reading (dBm)	S.G Power Value (dBm)	Correction Factor (dB)	EIRP (dBm)	Limit (dBm)	Margin (dB)
1	1732.50	-13.5	24.8	0.6	25.4	30.0	-4.6

Mode		TX channel 20375					
Antenna Polarity & Test Distance: Horizontal at 3 M							
No.	Freq. (MHz)	Reading (dBm)	S.G Power Value (dBm)	Correction Factor (dB)	EIRP (dBm)	Limit (dBm)	Margin (dB)
1	1752.50	-18.5	20.3	0.5	20.8	30.0	-9.2
Antenna Polarity & Test Distance: Vertical at 3 M							
No.	Freq. (MHz)	Reading (dBm)	S.G Power Value (dBm)	Correction Factor (dB)	EIRP (dBm)	Limit (dBm)	Margin (dB)
1	1752.50	-13.8	25.0	0.5	25.5	30.0	-4.5

Note: EIRP (dBm) = S.G Power Value (dBm) + Correction Factor (dB).

LTE Band 4, Channel Bandwidth: 10MHz

Mode		TX channel 20000					
Antenna Polarity & Test Distance: Horizontal at 3 M							
No.	Freq. (MHz)	Reading (dBm)	S.G Power Value (dBm)	Correction Factor (dB)	EIRP (dBm)	Limit (dBm)	Margin (dB)
1	1715.00	-19.0	19.1	0.7	19.8	30.0	-10.2
Antenna Polarity & Test Distance: Vertical at 3 M							
No.	Freq. (MHz)	Reading (dBm)	S.G Power Value (dBm)	Correction Factor (dB)	EIRP (dBm)	Limit (dBm)	Margin (dB)
1	1715.00	-13.3	24.6	0.7	25.3	30.0	-4.7

Mode		TX channel 20175					
Antenna Polarity & Test Distance: Horizontal at 3 M							
No.	Freq. (MHz)	Reading (dBm)	S.G Power Value (dBm)	Correction Factor (dB)	EIRP (dBm)	Limit (dBm)	Margin (dB)
1	1732.50	-18.8	19.6	0.6	20.2	30.0	-9.8
Antenna Polarity & Test Distance: Vertical at 3 M							
No.	Freq. (MHz)	Reading (dBm)	S.G Power Value (dBm)	Correction Factor (dB)	EIRP (dBm)	Limit (dBm)	Margin (dB)
1	1732.50	-13.6	24.7	0.6	25.3	30.0	-4.7

Mode		TX channel 20350					
Antenna Polarity & Test Distance: Horizontal at 3 M							
No.	Freq. (MHz)	Reading (dBm)	S.G Power Value (dBm)	Correction Factor (dB)	EIRP (dBm)	Limit (dBm)	Margin (dB)
1	1750.00	-18.7	20.1	0.5	20.6	30.0	-9.4
Antenna Polarity & Test Distance: Vertical at 3 M							
No.	Freq. (MHz)	Reading (dBm)	S.G Power Value (dBm)	Correction Factor (dB)	EIRP (dBm)	Limit (dBm)	Margin (dB)
1	1750.00	-13.3	25.5	0.5	26.0	30.0	-4.0

Note: EIRP (dBm) = S.G Power Value (dBm) + Correction Factor (dB).

LTE Band 4, Channel Bandwidth: 15MHz

Mode		TX channel 20025					
Antenna Polarity & Test Distance: Horizontal at 3 M							
No.	Freq. (MHz)	Reading (dBm)	S.G Power Value (dBm)	Correction Factor (dB)	EIRP (dBm)	Limit (dBm)	Margin (dB)
1	1717.50	-18.7	19.4	0.7	20.1	30.0	-9.9
Antenna Polarity & Test Distance: Vertical at 3 M							
No.	Freq. (MHz)	Reading (dBm)	S.G Power Value (dBm)	Correction Factor (dB)	EIRP (dBm)	Limit (dBm)	Margin (dB)
1	1717.50	-13.6	24.4	0.7	25.1	30.0	-4.9

Mode		TX channel 20175					
Antenna Polarity & Test Distance: Horizontal at 3 M							
No.	Freq. (MHz)	Reading (dBm)	S.G Power Value (dBm)	Correction Factor (dB)	EIRP (dBm)	Limit (dBm)	Margin (dB)
1	1732.50	-18.6	19.8	0.6	20.4	30.0	-9.6
Antenna Polarity & Test Distance: Vertical at 3 M							
No.	Freq. (MHz)	Reading (dBm)	S.G Power Value (dBm)	Correction Factor (dB)	EIRP (dBm)	Limit (dBm)	Margin (dB)
1	1732.50	-13.4	24.9	0.6	25.5	30.0	-4.5

Mode		TX channel 20325					
Antenna Polarity & Test Distance: Horizontal at 3 M							
No.	Freq. (MHz)	Reading (dBm)	S.G Power Value (dBm)	Correction Factor (dB)	EIRP (dBm)	Limit (dBm)	Margin (dB)
1	1747.50	-19.0	19.7	0.5	20.2	30.0	-9.8
Antenna Polarity & Test Distance: Vertical at 3 M							
No.	Freq. (MHz)	Reading (dBm)	S.G Power Value (dBm)	Correction Factor (dB)	EIRP (dBm)	Limit (dBm)	Margin (dB)
1	1747.50	-13.1	25.6	0.5	26.1	30.0	-3.9

Note: EIRP (dBm) = S.G Power Value (dBm) + Correction Factor (dB).

LTE Band 4, Channel Bandwidth: 20MHz

Mode		TX channel 20050					
Antenna Polarity & Test Distance: Horizontal at 3 M							
No.	Freq. (MHz)	Reading (dBm)	S.G Power Value (dBm)	Correction Factor (dB)	EIRP (dBm)	Limit (dBm)	Margin (dB)
1	1720.00	-18.6	19.6	0.7	20.3	30.0	-9.7
Antenna Polarity & Test Distance: Vertical at 3 M							
No.	Freq. (MHz)	Reading (dBm)	S.G Power Value (dBm)	Correction Factor (dB)	EIRP (dBm)	Limit (dBm)	Margin (dB)
1	1720.00	-13.4	24.6	0.7	25.3	30.0	-4.7

Mode		TX channel 20175					
Antenna Polarity & Test Distance: Horizontal at 3 M							
No.	Freq. (MHz)	Reading (dBm)	S.G Power Value (dBm)	Correction Factor (dB)	EIRP (dBm)	Limit (dBm)	Margin (dB)
1	1732.50	-18.5	19.9	0.6	20.5	30.0	-9.5
Antenna Polarity & Test Distance: Vertical at 3 M							
No.	Freq. (MHz)	Reading (dBm)	S.G Power Value (dBm)	Correction Factor (dB)	EIRP (dBm)	Limit (dBm)	Margin (dB)
1	1732.50	-13.2	25.1	0.6	25.7	30.0	-4.3

Mode		TX channel 20300					
Antenna Polarity & Test Distance: Horizontal at 3 M							
No.	Freq. (MHz)	Reading (dBm)	S.G Power Value (dBm)	Correction Factor (dB)	EIRP (dBm)	Limit (dBm)	Margin (dB)
1	1745.00	-19.0	19.7	0.5	20.2	30.0	-9.8
Antenna Polarity & Test Distance: Vertical at 3 M							
No.	Freq. (MHz)	Reading (dBm)	S.G Power Value (dBm)	Correction Factor (dB)	EIRP (dBm)	Limit (dBm)	Margin (dB)
1	1745.00	-13.1	25.6	0.5	26.1	30.0	-3.9

Note: EIRP (dBm) = S.G Power Value (dBm) + Correction Factor (dB).

LTE Band 7, Channel Bandwidth: 5MHz

Mode		TX channel 20775					
Antenna Polarity & Test Distance: Horizontal at 3 M							
No.	Freq. (MHz)	Reading (dBm)	S.G Power Value (dBm)	Correction Factor (dB)	EIRP (dBm)	Limit (dBm)	Margin (dB)
1	2502.50	-19.7	21.8	0.2	22.0	33.0	-11.0
Antenna Polarity & Test Distance: Vertical at 3 M							
No.	Freq. (MHz)	Reading (dBm)	S.G Power Value (dBm)	Correction Factor (dB)	EIRP (dBm)	Limit (dBm)	Margin (dB)
1	2502.50	-14.6	28.9	0.2	29.1	33.0	-3.9

Mode		TX channel 21100					
Antenna Polarity & Test Distance: Horizontal at 3 M							
No.	Freq. (MHz)	Reading (dBm)	S.G Power Value (dBm)	Correction Factor (dB)	EIRP (dBm)	Limit (dBm)	Margin (dB)
1	2535.00	-20.3	21.4	0.2	21.6	33.0	-11.4
Antenna Polarity & Test Distance: Vertical at 3 M							
No.	Freq. (MHz)	Reading (dBm)	S.G Power Value (dBm)	Correction Factor (dB)	EIRP (dBm)	Limit (dBm)	Margin (dB)
1	2535.00	-14.2	29.4	0.2	29.6	33.0	-3.4

Mode		TX channel 21425					
Antenna Polarity & Test Distance: Horizontal at 3 M							
No.	Freq. (MHz)	Reading (dBm)	S.G Power Value (dBm)	Correction Factor (dB)	EIRP (dBm)	Limit (dBm)	Margin (dB)
1	2567.50	-20.0	22.0	0.2	22.2	33.0	-10.8
Antenna Polarity & Test Distance: Vertical at 3 M							
No.	Freq. (MHz)	Reading (dBm)	S.G Power Value (dBm)	Correction Factor (dB)	EIRP (dBm)	Limit (dBm)	Margin (dB)
1	2567.50	-13.8	29.9	0.2	30.1	33.0	-2.9

Note: EIRP (dBm) = S.G Power Value (dBm) + Correction Factor (dB).

LTE Band 7, Channel Bandwidth: 10MHz

Mode		TX channel 20800					
Antenna Polarity & Test Distance: Horizontal at 3 M							
No.	Freq. (MHz)	Reading (dBm)	S.G Power Value (dBm)	Correction Factor (dB)	EIRP (dBm)	Limit (dBm)	Margin (dB)
1	2505.00	-19.8	21.7	0.2	21.9	33.0	-11.1
Antenna Polarity & Test Distance: Vertical at 3 M							
No.	Freq. (MHz)	Reading (dBm)	S.G Power Value (dBm)	Correction Factor (dB)	EIRP (dBm)	Limit (dBm)	Margin (dB)
1	2505.00	-14.6	28.9	0.2	29.1	33.0	-3.9

Mode		TX channel 21100					
Antenna Polarity & Test Distance: Horizontal at 3 M							
No.	Freq. (MHz)	Reading (dBm)	S.G Power Value (dBm)	Correction Factor (dB)	EIRP (dBm)	Limit (dBm)	Margin (dB)
1	2535.00	-19.7	22.0	0.2	22.2	33.0	-10.8
Antenna Polarity & Test Distance: Vertical at 3 M							
No.	Freq. (MHz)	Reading (dBm)	S.G Power Value (dBm)	Correction Factor (dB)	EIRP (dBm)	Limit (dBm)	Margin (dB)
1	2535.00	-14.4	29.2	0.2	29.4	33.0	-3.6

Mode		TX channel 21400					
Antenna Polarity & Test Distance: Horizontal at 3 M							
No.	Freq. (MHz)	Reading (dBm)	S.G Power Value (dBm)	Correction Factor (dB)	EIRP (dBm)	Limit (dBm)	Margin (dB)
1	2565.00	-19.5	22.5	0.2	22.7	33.0	-10.3
Antenna Polarity & Test Distance: Vertical at 3 M							
No.	Freq. (MHz)	Reading (dBm)	S.G Power Value (dBm)	Correction Factor (dB)	EIRP (dBm)	Limit (dBm)	Margin (dB)
1	2565.00	-13.9	29.8	0.2	30.0	33.0	-3.0

Note: EIRP (dBm) = S.G Power Value (dBm) + Correction Factor (dB).

LTE Band 7, Channel Bandwidth: 15MHz

Mode		TX channel 20825					
Antenna Polarity & Test Distance: Horizontal at 3 M							
No.	Freq. (MHz)	Reading (dBm)	S.G Power Value (dBm)	Correction Factor (dB)	EIRP (dBm)	Limit (dBm)	Margin (dB)
1	2507.50	-20.0	21.5	0.2	21.7	33.0	-11.3
Antenna Polarity & Test Distance: Vertical at 3 M							
No.	Freq. (MHz)	Reading (dBm)	S.G Power Value (dBm)	Correction Factor (dB)	EIRP (dBm)	Limit (dBm)	Margin (dB)
1	2507.50	-14.2	29.3	0.2	29.5	33.0	-3.5

Mode		TX channel 21100					
Antenna Polarity & Test Distance: Horizontal at 3 M							
No.	Freq. (MHz)	Reading (dBm)	S.G Power Value (dBm)	Correction Factor (dB)	EIRP (dBm)	Limit (dBm)	Margin (dB)
1	2535.00	-19.9	21.8	0.2	22.0	33.0	-11.0
Antenna Polarity & Test Distance: Vertical at 3 M							
No.	Freq. (MHz)	Reading (dBm)	S.G Power Value (dBm)	Correction Factor (dB)	EIRP (dBm)	Limit (dBm)	Margin (dB)
1	2535.00	-14.4	29.2	0.2	29.4	33.0	-3.6

Mode		TX channel 21375					
Antenna Polarity & Test Distance: Horizontal at 3 M							
No.	Freq. (MHz)	Reading (dBm)	S.G Power Value (dBm)	Correction Factor (dB)	EIRP (dBm)	Limit (dBm)	Margin (dB)
1	2562.50	-20.3	21.7	0.2	21.9	33.0	-11.1
Antenna Polarity & Test Distance: Vertical at 3 M							
No.	Freq. (MHz)	Reading (dBm)	S.G Power Value (dBm)	Correction Factor (dB)	EIRP (dBm)	Limit (dBm)	Margin (dB)
1	2562.50	-14.2	29.5	0.2	29.7	33.0	-3.3

Note: EIRP (dBm) = S.G Power Value (dBm) + Correction Factor (dB).

LTE Band 7, Channel Bandwidth: 20MHz

Mode		TX channel 20850					
Antenna Polarity & Test Distance: Horizontal at 3 M							
No.	Freq. (MHz)	Reading (dBm)	S.G Power Value (dBm)	Correction Factor (dB)	EIRP (dBm)	Limit (dBm)	Margin (dB)
1	2510.00	-20.4	21.1	0.2	21.3	33.0	-11.7
Antenna Polarity & Test Distance: Vertical at 3 M							
No.	Freq. (MHz)	Reading (dBm)	S.G Power Value (dBm)	Correction Factor (dB)	EIRP (dBm)	Limit (dBm)	Margin (dB)
1	2510.00	-14.4	29.1	0.2	29.3	33.0	-3.7

Mode		TX channel 21100					
Antenna Polarity & Test Distance: Horizontal at 3 M							
No.	Freq. (MHz)	Reading (dBm)	S.G Power Value (dBm)	Correction Factor (dB)	EIRP (dBm)	Limit (dBm)	Margin (dB)
1	2535.00	-19.7	22.0	0.2	22.2	33.0	-10.8
Antenna Polarity & Test Distance: Vertical at 3 M							
No.	Freq. (MHz)	Reading (dBm)	S.G Power Value (dBm)	Correction Factor (dB)	EIRP (dBm)	Limit (dBm)	Margin (dB)
1	2535.00	-14.5	29.1	0.2	29.3	33.0	-3.7

Mode		TX channel 21350					
Antenna Polarity & Test Distance: Horizontal at 3 M							
No.	Freq. (MHz)	Reading (dBm)	S.G Power Value (dBm)	Correction Factor (dB)	EIRP (dBm)	Limit (dBm)	Margin (dB)
1	2560.00	-19.8	22.1	0.2	22.3	33.0	-10.7
Antenna Polarity & Test Distance: Vertical at 3 M							
No.	Freq. (MHz)	Reading (dBm)	S.G Power Value (dBm)	Correction Factor (dB)	EIRP (dBm)	Limit (dBm)	Margin (dB)
1	2560.00	-14.6	29.1	0.2	29.3	33.0	-3.7

Note: EIRP (dBm) = S.G Power Value (dBm) + Correction Factor (dB).

Modulation Type: 16QAM

LTE Band 4, Channel Bandwidth: 1.4MHz

Mode		TX channel 19957					
Antenna Polarity & Test Distance: Horizontal at 3 M							
No.	Freq. (MHz)	Reading (dBm)	S.G Power Value (dBm)	Correction Factor (dB)	EIRP (dBm)	Limit (dBm)	Margin (dB)
1	1710.70	-19.6	18.4	0.7	19.1	30.0	-10.9
Antenna Polarity & Test Distance: Vertical at 3 M							
No.	Freq. (MHz)	Reading (dBm)	S.G Power Value (dBm)	Correction Factor (dB)	EIRP (dBm)	Limit (dBm)	Margin (dB)
1	1710.70	-14.3	23.5	0.7	24.2	30.0	-5.8

Mode		TX channel 20175					
Antenna Polarity & Test Distance: Horizontal at 3 M							
No.	Freq. (MHz)	Reading (dBm)	S.G Power Value (dBm)	Correction Factor (dB)	EIRP (dBm)	Limit (dBm)	Margin (dB)
1	1732.50	-19.8	18.6	0.6	19.2	30.0	-10.8
Antenna Polarity & Test Distance: Vertical at 3 M							
No.	Freq. (MHz)	Reading (dBm)	S.G Power Value (dBm)	Correction Factor (dB)	EIRP (dBm)	Limit (dBm)	Margin (dB)
1	1732.50	-14.0	24.3	0.6	24.9	30.0	-5.1

Mode		TX channel 20393					
Antenna Polarity & Test Distance: Horizontal at 3 M							
No.	Freq. (MHz)	Reading (dBm)	S.G Power Value (dBm)	Correction Factor (dB)	EIRP (dBm)	Limit (dBm)	Margin (dB)
1	1754.30	-19.6	19.2	0.5	19.7	30.0	-10.3
Antenna Polarity & Test Distance: Vertical at 3 M							
No.	Freq. (MHz)	Reading (dBm)	S.G Power Value (dBm)	Correction Factor (dB)	EIRP (dBm)	Limit (dBm)	Margin (dB)
1	1754.30	-14.1	24.8	0.5	25.3	30.0	-4.7

Note: EIRP (dBm) = S.G Power Value (dBm) + Correction Factor (dB).

LTE Band 4, Channel Bandwidth: 3MHz

Mode		TX channel 19965					
Antenna Polarity & Test Distance: Horizontal at 3 M							
No.	Freq. (MHz)	Reading (dBm)	S.G Power Value (dBm)	Correction Factor (dB)	EIRP (dBm)	Limit (dBm)	Margin (dB)
1	1711.50	-19.3	18.7	0.7	19.4	30.0	-10.6
Antenna Polarity & Test Distance: Vertical at 3 M							
No.	Freq. (MHz)	Reading (dBm)	S.G Power Value (dBm)	Correction Factor (dB)	EIRP (dBm)	Limit (dBm)	Margin (dB)
1	1711.50	-14.9	22.9	0.7	23.6	30.0	-6.4

Mode		TX channel 20175					
Antenna Polarity & Test Distance: Horizontal at 3 M							
No.	Freq. (MHz)	Reading (dBm)	S.G Power Value (dBm)	Correction Factor (dB)	EIRP (dBm)	Limit (dBm)	Margin (dB)
1	1732.50	-19.8	18.6	0.6	19.2	30.0	-10.8
Antenna Polarity & Test Distance: Vertical at 3 M							
No.	Freq. (MHz)	Reading (dBm)	S.G Power Value (dBm)	Correction Factor (dB)	EIRP (dBm)	Limit (dBm)	Margin (dB)
1	1732.50	-14.2	24.1	0.6	24.7	30.0	-5.3

Mode		TX channel 20385					
Antenna Polarity & Test Distance: Horizontal at 3 M							
No.	Freq. (MHz)	Reading (dBm)	S.G Power Value (dBm)	Correction Factor (dB)	EIRP (dBm)	Limit (dBm)	Margin (dB)
1	1753.50	-19.7	19.1	0.5	19.6	30.0	-10.4
Antenna Polarity & Test Distance: Vertical at 3 M							
No.	Freq. (MHz)	Reading (dBm)	S.G Power Value (dBm)	Correction Factor (dB)	EIRP (dBm)	Limit (dBm)	Margin (dB)
1	1753.50	-14.4	24.5	0.5	25.0	30.0	-5.0

Note: EIRP (dBm) = S.G Power Value (dBm) + Correction Factor (dB).

LTE Band 4, Channel Bandwidth: 5MHz

Mode		TX channel 19975					
Antenna Polarity & Test Distance: Horizontal at 3 M							
No.	Freq. (MHz)	Reading (dBm)	S.G Power Value (dBm)	Correction Factor (dB)	EIRP (dBm)	Limit (dBm)	Margin (dB)
1	1712.50	-19.6	18.5	0.7	19.2	30.0	-10.8
Antenna Polarity & Test Distance: Vertical at 3 M							
No.	Freq. (MHz)	Reading (dBm)	S.G Power Value (dBm)	Correction Factor (dB)	EIRP (dBm)	Limit (dBm)	Margin (dB)
1	1712.50	-14.2	23.7	0.7	24.4	30.0	-5.6

Mode		TX channel 20175					
Antenna Polarity & Test Distance: Horizontal at 3 M							
No.	Freq. (MHz)	Reading (dBm)	S.G Power Value (dBm)	Correction Factor (dB)	EIRP (dBm)	Limit (dBm)	Margin (dB)
1	1732.50	-20.4	18.0	0.6	18.6	30.0	-11.4
Antenna Polarity & Test Distance: Vertical at 3 M							
No.	Freq. (MHz)	Reading (dBm)	S.G Power Value (dBm)	Correction Factor (dB)	EIRP (dBm)	Limit (dBm)	Margin (dB)
1	1732.50	-14.0	24.3	0.6	24.9	30.0	-5.1

Mode		TX channel 20375					
Antenna Polarity & Test Distance: Horizontal at 3 M							
No.	Freq. (MHz)	Reading (dBm)	S.G Power Value (dBm)	Correction Factor (dB)	EIRP (dBm)	Limit (dBm)	Margin (dB)
1	1752.50	-19.8	19.0	0.5	19.5	30.0	-10.5
Antenna Polarity & Test Distance: Vertical at 3 M							
No.	Freq. (MHz)	Reading (dBm)	S.G Power Value (dBm)	Correction Factor (dB)	EIRP (dBm)	Limit (dBm)	Margin (dB)
1	1752.50	-14.4	24.4	0.5	24.9	30.0	-5.1

Note: EIRP (dBm) = S.G Power Value (dBm) + Correction Factor (dB).

LTE Band 4, Channel Bandwidth: 10MHz

Mode		TX channel 20000					
Antenna Polarity & Test Distance: Horizontal at 3 M							
No.	Freq. (MHz)	Reading (dBm)	S.G Power Value (dBm)	Correction Factor (dB)	EIRP (dBm)	Limit (dBm)	Margin (dB)
1	1715.00	-19.7	18.4	0.7	19.1	30.0	-10.9
Antenna Polarity & Test Distance: Vertical at 3 M							
No.	Freq. (MHz)	Reading (dBm)	S.G Power Value (dBm)	Correction Factor (dB)	EIRP (dBm)	Limit (dBm)	Margin (dB)
1	1715.00	-14.5	23.4	0.7	24.1	30.0	-5.9

Mode		TX channel 20175					
Antenna Polarity & Test Distance: Horizontal at 3 M							
No.	Freq. (MHz)	Reading (dBm)	S.G Power Value (dBm)	Correction Factor (dB)	EIRP (dBm)	Limit (dBm)	Margin (dB)
1	1732.50	-19.6	18.8	0.6	19.4	30.0	-10.6
Antenna Polarity & Test Distance: Vertical at 3 M							
No.	Freq. (MHz)	Reading (dBm)	S.G Power Value (dBm)	Correction Factor (dB)	EIRP (dBm)	Limit (dBm)	Margin (dB)
1	1732.50	-14.5	23.8	0.6	24.4	30.0	-5.6

Mode		TX channel 20350					
Antenna Polarity & Test Distance: Horizontal at 3 M							
No.	Freq. (MHz)	Reading (dBm)	S.G Power Value (dBm)	Correction Factor (dB)	EIRP (dBm)	Limit (dBm)	Margin (dB)
1	1750.00	-20.2	18.6	0.5	19.1	30.0	-10.9
Antenna Polarity & Test Distance: Vertical at 3 M							
No.	Freq. (MHz)	Reading (dBm)	S.G Power Value (dBm)	Correction Factor (dB)	EIRP (dBm)	Limit (dBm)	Margin (dB)
1	1750.00	-14.4	24.4	0.5	24.9	30.0	-5.1

Note: EIRP (dBm) = S.G Power Value (dBm) + Correction Factor (dB).

LTE Band 4, Channel Bandwidth: 15MHz

Mode		TX channel 20025					
Antenna Polarity & Test Distance: Horizontal at 3 M							
No.	Freq. (MHz)	Reading (dBm)	S.G Power Value (dBm)	Correction Factor (dB)	EIRP (dBm)	Limit (dBm)	Margin (dB)
1	1717.50	-19.8	18.3	0.7	19.0	30.0	-11.0
Antenna Polarity & Test Distance: Vertical at 3 M							
No.	Freq. (MHz)	Reading (dBm)	S.G Power Value (dBm)	Correction Factor (dB)	EIRP (dBm)	Limit (dBm)	Margin (dB)
1	1717.50	-14.3	23.7	0.7	24.4	30.0	-5.6

Mode		TX channel 20175					
Antenna Polarity & Test Distance: Horizontal at 3 M							
No.	Freq. (MHz)	Reading (dBm)	S.G Power Value (dBm)	Correction Factor (dB)	EIRP (dBm)	Limit (dBm)	Margin (dB)
1	1732.50	-19.2	19.2	0.6	19.8	30.0	-10.2
Antenna Polarity & Test Distance: Vertical at 3 M							
No.	Freq. (MHz)	Reading (dBm)	S.G Power Value (dBm)	Correction Factor (dB)	EIRP (dBm)	Limit (dBm)	Margin (dB)
1	1732.50	-14.4	23.9	0.6	24.5	30.0	-5.5

Mode		TX channel 20325					
Antenna Polarity & Test Distance: Horizontal at 3 M							
No.	Freq. (MHz)	Reading (dBm)	S.G Power Value (dBm)	Correction Factor (dB)	EIRP (dBm)	Limit (dBm)	Margin (dB)
1	1747.50	-20.1	18.6	0.5	19.1	30.0	-10.9
Antenna Polarity & Test Distance: Vertical at 3 M							
No.	Freq. (MHz)	Reading (dBm)	S.G Power Value (dBm)	Correction Factor (dB)	EIRP (dBm)	Limit (dBm)	Margin (dB)
1	1747.50	-14.6	24.1	0.5	24.6	30.0	-5.4

Note: EIRP (dBm) = S.G Power Value (dBm) + Correction Factor (dB).

LTE Band 4, Channel Bandwidth: 20MHz

Mode		TX channel 20050					
Antenna Polarity & Test Distance: Horizontal at 3 M							
No.	Freq. (MHz)	Reading (dBm)	S.G Power Value (dBm)	Correction Factor (dB)	EIRP (dBm)	Limit (dBm)	Margin (dB)
1	1720.00	-20.0	18.2	0.7	18.9	30.0	-11.1
Antenna Polarity & Test Distance: Vertical at 3 M							
No.	Freq. (MHz)	Reading (dBm)	S.G Power Value (dBm)	Correction Factor (dB)	EIRP (dBm)	Limit (dBm)	Margin (dB)
1	1720.00	-14.6	23.4	0.7	24.1	30.0	-5.9

Mode		TX channel 20175					
Antenna Polarity & Test Distance: Horizontal at 3 M							
No.	Freq. (MHz)	Reading (dBm)	S.G Power Value (dBm)	Correction Factor (dB)	EIRP (dBm)	Limit (dBm)	Margin (dB)
1	1732.50	-20.2	18.2	0.6	18.8	30.0	-11.2
Antenna Polarity & Test Distance: Vertical at 3 M							
No.	Freq. (MHz)	Reading (dBm)	S.G Power Value (dBm)	Correction Factor (dB)	EIRP (dBm)	Limit (dBm)	Margin (dB)
1	1732.50	-14.5	23.8	0.6	24.4	30.0	-5.6

Mode		TX channel 20300					
Antenna Polarity & Test Distance: Horizontal at 3 M							
No.	Freq. (MHz)	Reading (dBm)	S.G Power Value (dBm)	Correction Factor (dB)	EIRP (dBm)	Limit (dBm)	Margin (dB)
1	1745.00	-19.5	19.2	0.5	19.7	30.0	-10.3
Antenna Polarity & Test Distance: Vertical at 3 M							
No.	Freq. (MHz)	Reading (dBm)	S.G Power Value (dBm)	Correction Factor (dB)	EIRP (dBm)	Limit (dBm)	Margin (dB)
1	1745.00	-14.2	24.5	0.5	25.0	30.0	-5.0

Note: EIRP (dBm) = S.G Power Value (dBm) + Correction Factor (dB).

LTE Band 7, Channel Bandwidth: 5MHz

Mode		TX channel 20775					
Antenna Polarity & Test Distance: Horizontal at 3 M							
No.	Freq. (MHz)	Reading (dBm)	S.G Power Value (dBm)	Correction Factor (dB)	EIRP (dBm)	Limit (dBm)	Margin (dB)
1	2502.50	-20.1	21.4	0.2	21.6	33.0	-11.4
Antenna Polarity & Test Distance: Vertical at 3 M							
No.	Freq. (MHz)	Reading (dBm)	S.G Power Value (dBm)	Correction Factor (dB)	EIRP (dBm)	Limit (dBm)	Margin (dB)
1	2502.50	-14.9	28.6	0.2	28.8	33.0	-4.2

Mode		TX channel 21100					
Antenna Polarity & Test Distance: Horizontal at 3 M							
No.	Freq. (MHz)	Reading (dBm)	S.G Power Value (dBm)	Correction Factor (dB)	EIRP (dBm)	Limit (dBm)	Margin (dB)
1	2535.00	-21.2	20.5	0.2	20.7	33.0	-12.3
Antenna Polarity & Test Distance: Vertical at 3 M							
No.	Freq. (MHz)	Reading (dBm)	S.G Power Value (dBm)	Correction Factor (dB)	EIRP (dBm)	Limit (dBm)	Margin (dB)
1	2535.00	-14.7	28.9	0.2	29.1	33.0	-3.9

Mode		TX channel 21425					
Antenna Polarity & Test Distance: Horizontal at 3 M							
No.	Freq. (MHz)	Reading (dBm)	S.G Power Value (dBm)	Correction Factor (dB)	EIRP (dBm)	Limit (dBm)	Margin (dB)
1	2567.50	-20.3	21.7	0.2	21.9	33.0	-11.1
Antenna Polarity & Test Distance: Vertical at 3 M							
No.	Freq. (MHz)	Reading (dBm)	S.G Power Value (dBm)	Correction Factor (dB)	EIRP (dBm)	Limit (dBm)	Margin (dB)
1	2567.50	-15.0	28.7	0.2	28.9	33.0	-4.1

Note: EIRP (dBm) = S.G Power Value (dBm) + Correction Factor (dB).

LTE Band 7, Channel Bandwidth: 10MHz

Mode		TX channel 20800					
Antenna Polarity & Test Distance: Horizontal at 3 M							
No.	Freq. (MHz)	Reading (dBm)	S.G Power Value (dBm)	Correction Factor (dB)	EIRP (dBm)	Limit (dBm)	Margin (dB)
1	2505.00	-20.3	21.2	0.2	21.4	33.0	-11.6
Antenna Polarity & Test Distance: Vertical at 3 M							
No.	Freq. (MHz)	Reading (dBm)	S.G Power Value (dBm)	Correction Factor (dB)	EIRP (dBm)	Limit (dBm)	Margin (dB)
1	2505.00	-15.1	28.4	0.2	28.6	33.0	-4.4

Mode		TX channel 21100					
Antenna Polarity & Test Distance: Horizontal at 3 M							
No.	Freq. (MHz)	Reading (dBm)	S.G Power Value (dBm)	Correction Factor (dB)	EIRP (dBm)	Limit (dBm)	Margin (dB)
1	2535.00	-20.2	21.5	0.2	21.7	33.0	-11.3
Antenna Polarity & Test Distance: Vertical at 3 M							
No.	Freq. (MHz)	Reading (dBm)	S.G Power Value (dBm)	Correction Factor (dB)	EIRP (dBm)	Limit (dBm)	Margin (dB)
1	2535.00	-15.0	28.6	0.2	28.8	33.0	-4.2

Mode		TX channel 21400					
Antenna Polarity & Test Distance: Horizontal at 3 M							
No.	Freq. (MHz)	Reading (dBm)	S.G Power Value (dBm)	Correction Factor (dB)	EIRP (dBm)	Limit (dBm)	Margin (dB)
1	2565.00	-20.3	21.7	0.2	21.9	33.0	-11.1
Antenna Polarity & Test Distance: Vertical at 3 M							
No.	Freq. (MHz)	Reading (dBm)	S.G Power Value (dBm)	Correction Factor (dB)	EIRP (dBm)	Limit (dBm)	Margin (dB)
1	2565.00	-15.2	28.5	0.2	28.7	33.0	-4.3

Note: EIRP (dBm) = S.G Power Value (dBm) + Correction Factor (dB).

LTE Band 7, Channel Bandwidth: 15MHz

Mode		TX channel 20825					
Antenna Polarity & Test Distance: Horizontal at 3 M							
No.	Freq. (MHz)	Reading (dBm)	S.G Power Value (dBm)	Correction Factor (dB)	EIRP (dBm)	Limit (dBm)	Margin (dB)
1	2507.50	-21.2	20.3	0.2	20.5	33.0	-12.5
Antenna Polarity & Test Distance: Vertical at 3 M							
No.	Freq. (MHz)	Reading (dBm)	S.G Power Value (dBm)	Correction Factor (dB)	EIRP (dBm)	Limit (dBm)	Margin (dB)
1	2507.50	-14.9	28.6	0.2	28.8	33.0	-4.2

Mode		TX channel 21100					
Antenna Polarity & Test Distance: Horizontal at 3 M							
No.	Freq. (MHz)	Reading (dBm)	S.G Power Value (dBm)	Correction Factor (dB)	EIRP (dBm)	Limit (dBm)	Margin (dB)
1	2535.00	-20.5	21.2	0.2	21.4	33.0	-11.6
Antenna Polarity & Test Distance: Vertical at 3 M							
No.	Freq. (MHz)	Reading (dBm)	S.G Power Value (dBm)	Correction Factor (dB)	EIRP (dBm)	Limit (dBm)	Margin (dB)
1	2535.00	-15.5	28.1	0.2	28.3	33.0	-4.7

Mode		TX channel 21375					
Antenna Polarity & Test Distance: Horizontal at 3 M							
No.	Freq. (MHz)	Reading (dBm)	S.G Power Value (dBm)	Correction Factor (dB)	EIRP (dBm)	Limit (dBm)	Margin (dB)
1	2562.50	-21.2	20.8	0.2	21.0	33.0	-12.0
Antenna Polarity & Test Distance: Vertical at 3 M							
No.	Freq. (MHz)	Reading (dBm)	S.G Power Value (dBm)	Correction Factor (dB)	EIRP (dBm)	Limit (dBm)	Margin (dB)
1	2562.50	-15.0	28.7	0.2	28.9	33.0	-4.1

Note: EIRP (dBm) = S.G Power Value (dBm) + Correction Factor (dB).

LTE Band 7, Channel Bandwidth: 20MHz

Mode		TX channel 20850					
Antenna Polarity & Test Distance: Horizontal at 3 M							
No.	Freq. (MHz)	Reading (dBm)	S.G Power Value (dBm)	Correction Factor (dB)	EIRP (dBm)	Limit (dBm)	Margin (dB)
1	2510.00	-21.3	20.2	0.2	20.4	33.0	-12.6
Antenna Polarity & Test Distance: Vertical at 3 M							
No.	Freq. (MHz)	Reading (dBm)	S.G Power Value (dBm)	Correction Factor (dB)	EIRP (dBm)	Limit (dBm)	Margin (dB)
1	2510.00	-15.2	28.3	0.2	28.5	33.0	-4.5

Mode		TX channel 21100					
Antenna Polarity & Test Distance: Horizontal at 3 M							
No.	Freq. (MHz)	Reading (dBm)	S.G Power Value (dBm)	Correction Factor (dB)	EIRP (dBm)	Limit (dBm)	Margin (dB)
1	2535.00	-20.0	21.7	0.2	21.9	33.0	-11.1
Antenna Polarity & Test Distance: Vertical at 3 M							
No.	Freq. (MHz)	Reading (dBm)	S.G Power Value (dBm)	Correction Factor (dB)	EIRP (dBm)	Limit (dBm)	Margin (dB)
1	2535.00	-15.1	28.5	0.2	28.7	33.0	-4.3

Mode		TX channel 21350					
Antenna Polarity & Test Distance: Horizontal at 3 M							
No.	Freq. (MHz)	Reading (dBm)	S.G Power Value (dBm)	Correction Factor (dB)	EIRP (dBm)	Limit (dBm)	Margin (dB)
1	2560.00	-20.9	21.0	0.2	21.2	33.0	-11.8
Antenna Polarity & Test Distance: Vertical at 3 M							
No.	Freq. (MHz)	Reading (dBm)	S.G Power Value (dBm)	Correction Factor (dB)	EIRP (dBm)	Limit (dBm)	Margin (dB)
1	2560.00	-15.4	28.3	0.2	28.5	33.0	-4.5

Note: EIRP (dBm) = S.G Power Value (dBm) + Correction Factor (dB).

Modulation Type: 64QAM

LTE Band 4, Channel Bandwidth: 1.4MHz

Mode		TX channel 19957					
Antenna Polarity & Test Distance: Horizontal at 3 M							
No.	Freq. (MHz)	Reading (dBm)	S.G Power Value (dBm)	Correction Factor (dB)	EIRP (dBm)	Limit (dBm)	Margin (dB)
1	1710.70	-19.9	18.1	0.7	18.8	30.0	-11.2
Antenna Polarity & Test Distance: Vertical at 3 M							
No.	Freq. (MHz)	Reading (dBm)	S.G Power Value (dBm)	Correction Factor (dB)	EIRP (dBm)	Limit (dBm)	Margin (dB)
1	1710.70	-14.8	23.0	0.7	23.7	30.0	-6.3

Mode		TX channel 20175					
Antenna Polarity & Test Distance: Horizontal at 3 M							
No.	Freq. (MHz)	Reading (dBm)	S.G Power Value (dBm)	Correction Factor (dB)	EIRP (dBm)	Limit (dBm)	Margin (dB)
1	1732.50	-20.2	18.2	0.6	18.8	30.0	-11.2
Antenna Polarity & Test Distance: Vertical at 3 M							
No.	Freq. (MHz)	Reading (dBm)	S.G Power Value (dBm)	Correction Factor (dB)	EIRP (dBm)	Limit (dBm)	Margin (dB)
1	1732.50	-14.5	23.8	0.6	24.4	30.0	-5.6

Mode		TX channel 20393					
Antenna Polarity & Test Distance: Horizontal at 3 M							
No.	Freq. (MHz)	Reading (dBm)	S.G Power Value (dBm)	Correction Factor (dB)	EIRP (dBm)	Limit (dBm)	Margin (dB)
1	1754.30	-20.1	18.7	0.5	19.2	30.0	-10.8
Antenna Polarity & Test Distance: Vertical at 3 M							
No.	Freq. (MHz)	Reading (dBm)	S.G Power Value (dBm)	Correction Factor (dB)	EIRP (dBm)	Limit (dBm)	Margin (dB)
1	1754.30	-14.5	24.4	0.5	24.9	30.0	-5.1

Note: EIRP (dBm) = S.G Power Value (dBm) + Correction Factor (dB).

LTE Band 4, Channel Bandwidth: 3MHz

Mode		TX channel 19965					
Antenna Polarity & Test Distance: Horizontal at 3 M							
No.	Freq. (MHz)	Reading (dBm)	S.G Power Value (dBm)	Correction Factor (dB)	EIRP (dBm)	Limit (dBm)	Margin (dB)
1	1711.50	-19.7	18.3	0.7	19.0	30.0	-11.0
Antenna Polarity & Test Distance: Vertical at 3 M							
No.	Freq. (MHz)	Reading (dBm)	S.G Power Value (dBm)	Correction Factor (dB)	EIRP (dBm)	Limit (dBm)	Margin (dB)
1	1711.50	-15.4	22.4	0.7	23.1	30.0	-6.9

Mode		TX channel 20175					
Antenna Polarity & Test Distance: Horizontal at 3 M							
No.	Freq. (MHz)	Reading (dBm)	S.G Power Value (dBm)	Correction Factor (dB)	EIRP (dBm)	Limit (dBm)	Margin (dB)
1	1732.50	-20.2	18.2	0.6	18.8	30.0	-11.2
Antenna Polarity & Test Distance: Vertical at 3 M							
No.	Freq. (MHz)	Reading (dBm)	S.G Power Value (dBm)	Correction Factor (dB)	EIRP (dBm)	Limit (dBm)	Margin (dB)
1	1732.50	-14.7	23.6	0.6	24.2	30.0	-5.8

Mode		TX channel 20385					
Antenna Polarity & Test Distance: Horizontal at 3 M							
No.	Freq. (MHz)	Reading (dBm)	S.G Power Value (dBm)	Correction Factor (dB)	EIRP (dBm)	Limit (dBm)	Margin (dB)
1	1753.50	-20.1	18.7	0.5	19.2	30.0	-10.8
Antenna Polarity & Test Distance: Vertical at 3 M							
No.	Freq. (MHz)	Reading (dBm)	S.G Power Value (dBm)	Correction Factor (dB)	EIRP (dBm)	Limit (dBm)	Margin (dB)
1	1753.50	-14.9	24.0	0.5	24.5	30.0	-5.5

Note: EIRP (dBm) = S.G Power Value (dBm) + Correction Factor (dB).

LTE Band 4, Channel Bandwidth: 5MHz

Mode		TX channel 19975					
Antenna Polarity & Test Distance: Horizontal at 3 M							
No.	Freq. (MHz)	Reading (dBm)	S.G Power Value (dBm)	Correction Factor (dB)	EIRP (dBm)	Limit (dBm)	Margin (dB)
1	1712.50	-19.9	18.2	0.7	18.9	30.0	-11.1
Antenna Polarity & Test Distance: Vertical at 3 M							
No.	Freq. (MHz)	Reading (dBm)	S.G Power Value (dBm)	Correction Factor (dB)	EIRP (dBm)	Limit (dBm)	Margin (dB)
1	1712.50	-14.7	23.2	0.7	23.9	30.0	-6.1

Mode		TX channel 20175					
Antenna Polarity & Test Distance: Horizontal at 3 M							
No.	Freq. (MHz)	Reading (dBm)	S.G Power Value (dBm)	Correction Factor (dB)	EIRP (dBm)	Limit (dBm)	Margin (dB)
1	1732.50	-20.8	17.6	0.6	18.2	30.0	-11.8
Antenna Polarity & Test Distance: Vertical at 3 M							
No.	Freq. (MHz)	Reading (dBm)	S.G Power Value (dBm)	Correction Factor (dB)	EIRP (dBm)	Limit (dBm)	Margin (dB)
1	1732.50	-14.4	23.9	0.6	24.5	30.0	-5.5

Mode		TX channel 20375					
Antenna Polarity & Test Distance: Horizontal at 3 M							
No.	Freq. (MHz)	Reading (dBm)	S.G Power Value (dBm)	Correction Factor (dB)	EIRP (dBm)	Limit (dBm)	Margin (dB)
1	1752.50	-20.2	18.6	0.5	19.1	30.0	-10.9
Antenna Polarity & Test Distance: Vertical at 3 M							
No.	Freq. (MHz)	Reading (dBm)	S.G Power Value (dBm)	Correction Factor (dB)	EIRP (dBm)	Limit (dBm)	Margin (dB)
1	1752.50	-14.9	23.9	0.5	24.4	30.0	-5.6

Note: EIRP (dBm) = S.G Power Value (dBm) + Correction Factor (dB).

LTE Band 4, Channel Bandwidth: 10MHz

Mode		TX channel 20000					
Antenna Polarity & Test Distance: Horizontal at 3 M							
No.	Freq. (MHz)	Reading (dBm)	S.G Power Value (dBm)	Correction Factor (dB)	EIRP (dBm)	Limit (dBm)	Margin (dB)
1	1715.00	-20.1	18.0	0.7	18.7	30.0	-11.3
Antenna Polarity & Test Distance: Vertical at 3 M							
No.	Freq. (MHz)	Reading (dBm)	S.G Power Value (dBm)	Correction Factor (dB)	EIRP (dBm)	Limit (dBm)	Margin (dB)
1	1715.00	-14.8	23.1	0.7	23.8	30.0	-6.2

Mode		TX channel 20175					
Antenna Polarity & Test Distance: Horizontal at 3 M							
No.	Freq. (MHz)	Reading (dBm)	S.G Power Value (dBm)	Correction Factor (dB)	EIRP (dBm)	Limit (dBm)	Margin (dB)
1	1732.50	-20.0	18.4	0.6	19.0	30.0	-11.0
Antenna Polarity & Test Distance: Vertical at 3 M							
No.	Freq. (MHz)	Reading (dBm)	S.G Power Value (dBm)	Correction Factor (dB)	EIRP (dBm)	Limit (dBm)	Margin (dB)
1	1732.50	-14.9	23.4	0.6	24.0	30.0	-6.0

Mode		TX channel 20350					
Antenna Polarity & Test Distance: Horizontal at 3 M							
No.	Freq. (MHz)	Reading (dBm)	S.G Power Value (dBm)	Correction Factor (dB)	EIRP (dBm)	Limit (dBm)	Margin (dB)
1	1750.00	-20.4	18.4	0.5	18.9	30.0	-11.1
Antenna Polarity & Test Distance: Vertical at 3 M							
No.	Freq. (MHz)	Reading (dBm)	S.G Power Value (dBm)	Correction Factor (dB)	EIRP (dBm)	Limit (dBm)	Margin (dB)
1	1750.00	-14.7	24.1	0.5	24.6	30.0	-5.4

Note: EIRP (dBm) = S.G Power Value (dBm) + Correction Factor (dB).

LTE Band 4, Channel Bandwidth: 15MHz

Mode		TX channel 20025					
Antenna Polarity & Test Distance: Horizontal at 3 M							
No.	Freq. (MHz)	Reading (dBm)	S.G Power Value (dBm)	Correction Factor (dB)	EIRP (dBm)	Limit (dBm)	Margin (dB)
1	1717.50	-20.2	17.9	0.7	18.6	30.0	-11.4
Antenna Polarity & Test Distance: Vertical at 3 M							
No.	Freq. (MHz)	Reading (dBm)	S.G Power Value (dBm)	Correction Factor (dB)	EIRP (dBm)	Limit (dBm)	Margin (dB)
1	1717.50	-14.8	23.2	0.7	23.9	30.0	-6.1

Mode		TX channel 20175					
Antenna Polarity & Test Distance: Horizontal at 3 M							
No.	Freq. (MHz)	Reading (dBm)	S.G Power Value (dBm)	Correction Factor (dB)	EIRP (dBm)	Limit (dBm)	Margin (dB)
1	1732.50	-19.7	18.7	0.6	19.3	30.0	-10.7
Antenna Polarity & Test Distance: Vertical at 3 M							
No.	Freq. (MHz)	Reading (dBm)	S.G Power Value (dBm)	Correction Factor (dB)	EIRP (dBm)	Limit (dBm)	Margin (dB)
1	1732.50	-14.9	23.4	0.6	24.0	30.0	-6.0

Mode		TX channel 20325					
Antenna Polarity & Test Distance: Horizontal at 3 M							
No.	Freq. (MHz)	Reading (dBm)	S.G Power Value (dBm)	Correction Factor (dB)	EIRP (dBm)	Limit (dBm)	Margin (dB)
1	1747.50	-20.4	18.3	0.5	18.8	30.0	-11.2
Antenna Polarity & Test Distance: Vertical at 3 M							
No.	Freq. (MHz)	Reading (dBm)	S.G Power Value (dBm)	Correction Factor (dB)	EIRP (dBm)	Limit (dBm)	Margin (dB)
1	1747.50	-15.0	23.7	0.5	24.2	30.0	-5.8

Note: EIRP (dBm) = S.G Power Value (dBm) + Correction Factor (dB).

LTE Band 4, Channel Bandwidth: 20MHz

Mode		TX channel 20050					
Antenna Polarity & Test Distance: Horizontal at 3 M							
No.	Freq. (MHz)	Reading (dBm)	S.G Power Value (dBm)	Correction Factor (dB)	EIRP (dBm)	Limit (dBm)	Margin (dB)
1	1720.00	-20.3	17.9	0.7	18.6	30.0	-11.4
Antenna Polarity & Test Distance: Vertical at 3 M							
No.	Freq. (MHz)	Reading (dBm)	S.G Power Value (dBm)	Correction Factor (dB)	EIRP (dBm)	Limit (dBm)	Margin (dB)
1	1720.00	-15.0	23.0	0.7	23.7	30.0	-6.3

Mode		TX channel 20175					
Antenna Polarity & Test Distance: Horizontal at 3 M							
No.	Freq. (MHz)	Reading (dBm)	S.G Power Value (dBm)	Correction Factor (dB)	EIRP (dBm)	Limit (dBm)	Margin (dB)
1	1732.50	-20.6	17.8	0.6	18.4	30.0	-11.6
Antenna Polarity & Test Distance: Vertical at 3 M							
No.	Freq. (MHz)	Reading (dBm)	S.G Power Value (dBm)	Correction Factor (dB)	EIRP (dBm)	Limit (dBm)	Margin (dB)
1	1732.50	-14.8	23.5	0.6	24.1	30.0	-5.9

Mode		TX channel 20300					
Antenna Polarity & Test Distance: Horizontal at 3 M							
No.	Freq. (MHz)	Reading (dBm)	S.G Power Value (dBm)	Correction Factor (dB)	EIRP (dBm)	Limit (dBm)	Margin (dB)
1	1745.00	-19.7	19.0	0.5	19.5	30.0	-10.5
Antenna Polarity & Test Distance: Vertical at 3 M							
No.	Freq. (MHz)	Reading (dBm)	S.G Power Value (dBm)	Correction Factor (dB)	EIRP (dBm)	Limit (dBm)	Margin (dB)
1	1745.00	-14.6	24.1	0.5	24.6	30.0	-5.4

Note: EIRP (dBm) = S.G Power Value (dBm) + Correction Factor (dB).

LTE Band 7, Channel Bandwidth: 5MHz

Mode		TX channel 20775					
Antenna Polarity & Test Distance: Horizontal at 3 M							
No.	Freq. (MHz)	Reading (dBm)	S.G Power Value (dBm)	Correction Factor (dB)	EIRP (dBm)	Limit (dBm)	Margin (dB)
1	2502.50	-20.6	20.9	0.2	21.1	33.0	-11.9
Antenna Polarity & Test Distance: Vertical at 3 M							
No.	Freq. (MHz)	Reading (dBm)	S.G Power Value (dBm)	Correction Factor (dB)	EIRP (dBm)	Limit (dBm)	Margin (dB)
1	2502.50	-15.3	28.2	0.2	28.4	33.0	-4.6

Mode		TX channel 21100					
Antenna Polarity & Test Distance: Horizontal at 3 M							
No.	Freq. (MHz)	Reading (dBm)	S.G Power Value (dBm)	Correction Factor (dB)	EIRP (dBm)	Limit (dBm)	Margin (dB)
1	2535.00	-21.7	20.0	0.2	20.2	33.0	-12.8
Antenna Polarity & Test Distance: Vertical at 3 M							
No.	Freq. (MHz)	Reading (dBm)	S.G Power Value (dBm)	Correction Factor (dB)	EIRP (dBm)	Limit (dBm)	Margin (dB)
1	2535.00	-15.2	28.4	0.2	28.6	33.0	-4.4

Mode		TX channel 21425					
Antenna Polarity & Test Distance: Horizontal at 3 M							
No.	Freq. (MHz)	Reading (dBm)	S.G Power Value (dBm)	Correction Factor (dB)	EIRP (dBm)	Limit (dBm)	Margin (dB)
1	2567.50	-20.8	21.2	0.2	21.4	33.0	-11.6
Antenna Polarity & Test Distance: Vertical at 3 M							
No.	Freq. (MHz)	Reading (dBm)	S.G Power Value (dBm)	Correction Factor (dB)	EIRP (dBm)	Limit (dBm)	Margin (dB)
1	2567.50	-15.5	28.2	0.2	28.4	33.0	-4.6

Note: EIRP (dBm) = S.G Power Value (dBm) + Correction Factor (dB).

LTE Band 7, Channel Bandwidth: 10MHz

Mode		TX channel 20800					
Antenna Polarity & Test Distance: Horizontal at 3 M							
No.	Freq. (MHz)	Reading (dBm)	S.G Power Value (dBm)	Correction Factor (dB)	EIRP (dBm)	Limit (dBm)	Margin (dB)
1	2505.00	-20.7	20.8	0.2	21.0	33.0	-12.0
Antenna Polarity & Test Distance: Vertical at 3 M							
No.	Freq. (MHz)	Reading (dBm)	S.G Power Value (dBm)	Correction Factor (dB)	EIRP (dBm)	Limit (dBm)	Margin (dB)
1	2505.00	-15.5	28.0	0.2	28.2	33.0	-4.8

Mode		TX channel 21100					
Antenna Polarity & Test Distance: Horizontal at 3 M							
No.	Freq. (MHz)	Reading (dBm)	S.G Power Value (dBm)	Correction Factor (dB)	EIRP (dBm)	Limit (dBm)	Margin (dB)
1	2535.00	-20.7	21.0	0.2	21.2	33.0	-11.8
Antenna Polarity & Test Distance: Vertical at 3 M							
No.	Freq. (MHz)	Reading (dBm)	S.G Power Value (dBm)	Correction Factor (dB)	EIRP (dBm)	Limit (dBm)	Margin (dB)
1	2535.00	-15.4	28.2	0.2	28.4	33.0	-4.6

Mode		TX channel 21400					
Antenna Polarity & Test Distance: Horizontal at 3 M							
No.	Freq. (MHz)	Reading (dBm)	S.G Power Value (dBm)	Correction Factor (dB)	EIRP (dBm)	Limit (dBm)	Margin (dB)
1	2565.00	-20.7	21.3	0.2	21.5	33.0	-11.5
Antenna Polarity & Test Distance: Vertical at 3 M							
No.	Freq. (MHz)	Reading (dBm)	S.G Power Value (dBm)	Correction Factor (dB)	EIRP (dBm)	Limit (dBm)	Margin (dB)
1	2565.00	-15.8	27.9	0.2	28.1	33.0	-4.9

Note: EIRP (dBm) = S.G Power Value (dBm) + Correction Factor (dB).

LTE Band 7, Channel Bandwidth: 15MHz

Mode		TX channel 20825					
Antenna Polarity & Test Distance: Horizontal at 3 M							
No.	Freq. (MHz)	Reading (dBm)	S.G Power Value (dBm)	Correction Factor (dB)	EIRP (dBm)	Limit (dBm)	Margin (dB)
1	2507.50	-21.5	20.0	0.2	20.2	33.0	-12.8
Antenna Polarity & Test Distance: Vertical at 3 M							
No.	Freq. (MHz)	Reading (dBm)	S.G Power Value (dBm)	Correction Factor (dB)	EIRP (dBm)	Limit (dBm)	Margin (dB)
1	2507.50	-15.1	28.4	0.2	28.6	33.0	-4.4

Mode		TX channel 21100					
Antenna Polarity & Test Distance: Horizontal at 3 M							
No.	Freq. (MHz)	Reading (dBm)	S.G Power Value (dBm)	Correction Factor (dB)	EIRP (dBm)	Limit (dBm)	Margin (dB)
1	2535.00	-20.8	20.9	0.2	21.1	33.0	-11.9
Antenna Polarity & Test Distance: Vertical at 3 M							
No.	Freq. (MHz)	Reading (dBm)	S.G Power Value (dBm)	Correction Factor (dB)	EIRP (dBm)	Limit (dBm)	Margin (dB)
1	2535.00	-15.8	27.8	0.2	28.0	33.0	-5.0

Mode		TX channel 21375					
Antenna Polarity & Test Distance: Horizontal at 3 M							
No.	Freq. (MHz)	Reading (dBm)	S.G Power Value (dBm)	Correction Factor (dB)	EIRP (dBm)	Limit (dBm)	Margin (dB)
1	2562.50	-21.4	20.6	0.2	20.8	33.0	-12.2
Antenna Polarity & Test Distance: Vertical at 3 M							
No.	Freq. (MHz)	Reading (dBm)	S.G Power Value (dBm)	Correction Factor (dB)	EIRP (dBm)	Limit (dBm)	Margin (dB)
1	2562.50	-15.3	28.4	0.2	28.6	33.0	-4.4

Note: EIRP (dBm) = S.G Power Value (dBm) + Correction Factor (dB).

LTE Band 7, Channel Bandwidth: 20MHz

Mode		TX channel 20850					
Antenna Polarity & Test Distance: Horizontal at 3 M							
No.	Freq. (MHz)	Reading (dBm)	S.G Power Value (dBm)	Correction Factor (dB)	EIRP (dBm)	Limit (dBm)	Margin (dB)
1	2510.00	-21.5	20.0	0.2	20.2	33.0	-12.8
Antenna Polarity & Test Distance: Vertical at 3 M							
No.	Freq. (MHz)	Reading (dBm)	S.G Power Value (dBm)	Correction Factor (dB)	EIRP (dBm)	Limit (dBm)	Margin (dB)
1	2510.00	-15.4	28.1	0.2	28.3	33.0	-4.7

Mode		TX channel 21100					
Antenna Polarity & Test Distance: Horizontal at 3 M							
No.	Freq. (MHz)	Reading (dBm)	S.G Power Value (dBm)	Correction Factor (dB)	EIRP (dBm)	Limit (dBm)	Margin (dB)
1	2535.00	-20.2	21.5	0.2	21.7	33.0	-11.3
Antenna Polarity & Test Distance: Vertical at 3 M							
No.	Freq. (MHz)	Reading (dBm)	S.G Power Value (dBm)	Correction Factor (dB)	EIRP (dBm)	Limit (dBm)	Margin (dB)
1	2535.00	-15.3	28.3	0.2	28.5	33.0	-4.5

Mode		TX channel 21350					
Antenna Polarity & Test Distance: Horizontal at 3 M							
No.	Freq. (MHz)	Reading (dBm)	S.G Power Value (dBm)	Correction Factor (dB)	EIRP (dBm)	Limit (dBm)	Margin (dB)
1	2560.00	-21.1	20.8	0.2	21.0	33.0	-12.0
Antenna Polarity & Test Distance: Vertical at 3 M							
No.	Freq. (MHz)	Reading (dBm)	S.G Power Value (dBm)	Correction Factor (dB)	EIRP (dBm)	Limit (dBm)	Margin (dB)
1	2560.00	-15.6	28.1	0.2	28.3	33.0	-4.7

Note: EIRP (dBm) = S.G Power Value (dBm) + Correction Factor (dB).

4.2 Modulation Characteristics Measurement

4.2.1 Limits of Modulation Characteristics

N/A

4.2.2 Test Procedure

Connect the EUT to Communication Simulator via the antenna connector, The frequency band is set as EUT supported Modulation and Channels, the EUT output is matched with 50 ohm load, the waveform quality and constellation of the EUT was tested.

4.2.3 Test Setup



4.2.4 Test Results

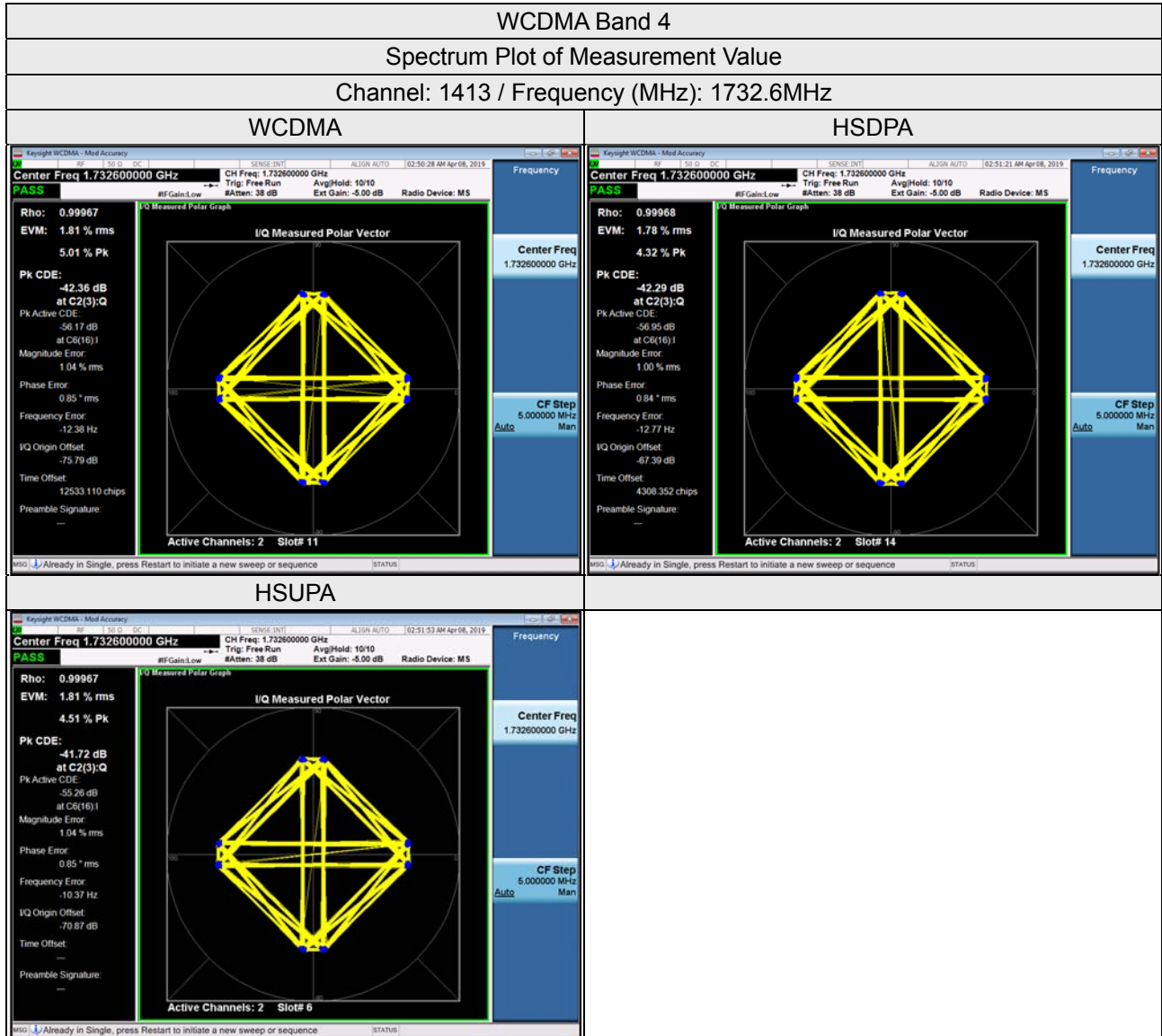

LTE Band 4

Spectrum Plot of Measurement Value

Channel: 20175 / Frequency (MHz): 1732.5MHz

QPSK

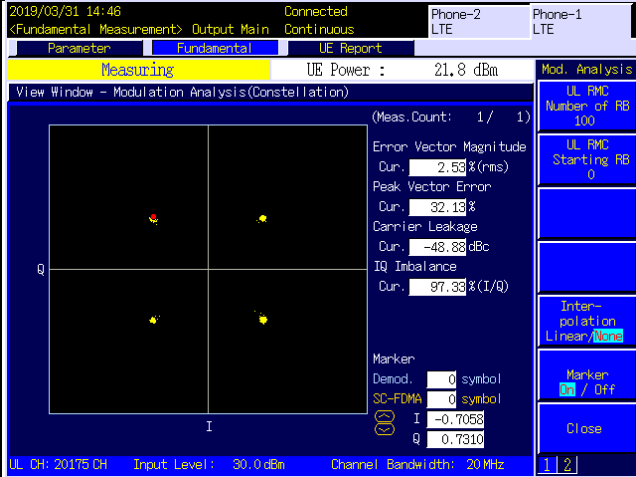

16QAM

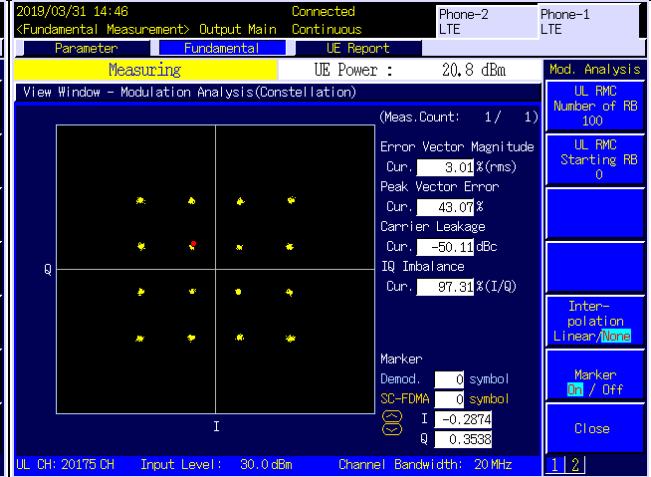

64QAM

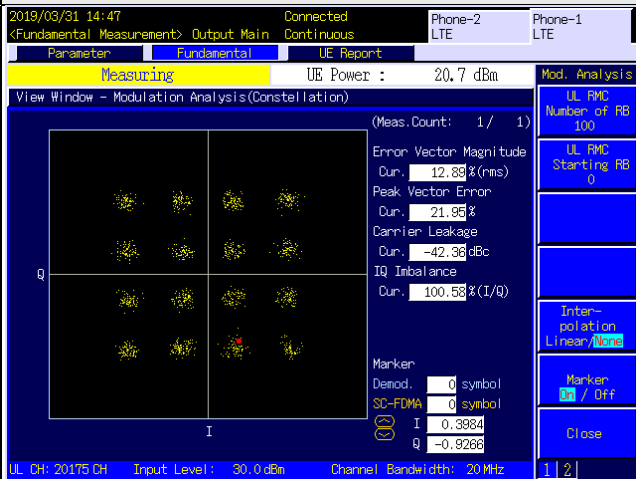

LTE Band 7

Spectrum Plot of Measurement Value

Channel: 21100 / Frequency (MHz): 2535 MHz

QPSK

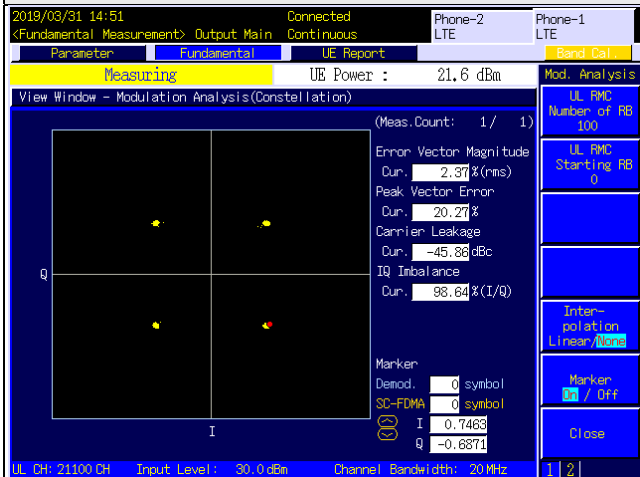

16QAM

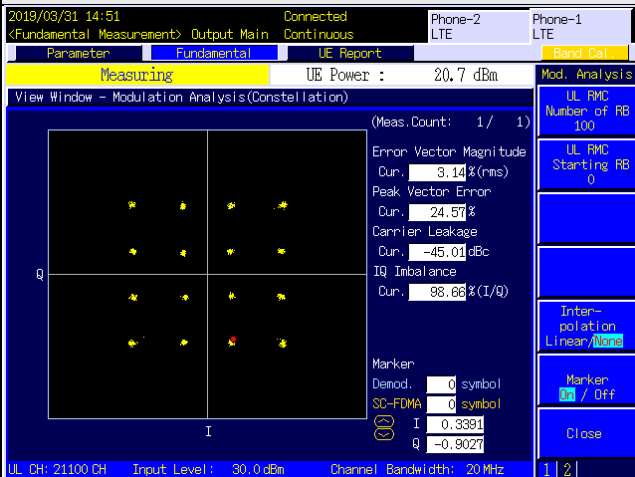

64QAM

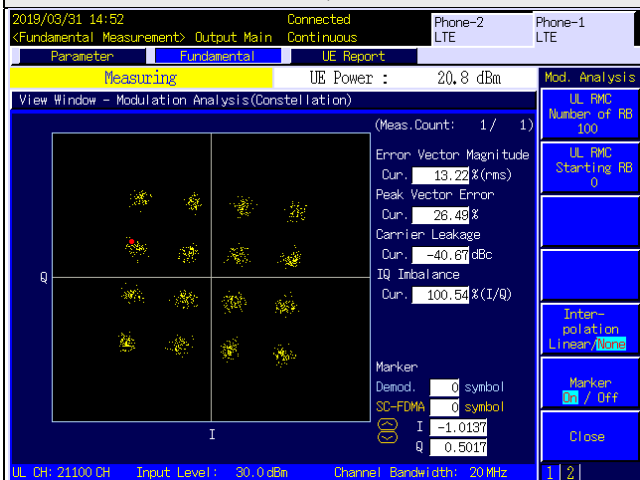

4.3 Frequency Stability Measurement

4.3.1 Limits of Frequency Stability Measurement

According to the FCC part 2.1055 shall be tested the frequency stability. The rule is defined that "The frequency stability shall be sufficient to ensure that the fundamental emission stays within the authorized frequency block." The test extreme voltage is according to the 2.1055(d)(1) Vary primary supply voltage from 85 to 115 percent of the nominal value for other than hand carried battery equipment and the extreme temperature rule is comply with specification of EUT $-30^{\circ}\text{C} \sim 50^{\circ}\text{C}$.

4.3.2 Test Procedure

- Device is placed at the oven room. The oven room could control the temperatures and humidity. Power warm up is at least 15 min and power applied should perform before recording frequency error.
- EUT is connected the external power supply to control the DC input power. The test voltage range is from minimum to maximum working voltage. Each step shall be record the frequency error rate.
- The temperature range step is 10 degrees in this test items. All temperature levels shall be hold the $\pm 0.5^{\circ}\text{C}$ during the measurement testing. The each temperature step shall be at least 0.5 hours, consider the EUT could be test under the stability condition.

Note: The frequency error was recorded frequency error from the communication simulator.

4.3.3 Test Setup

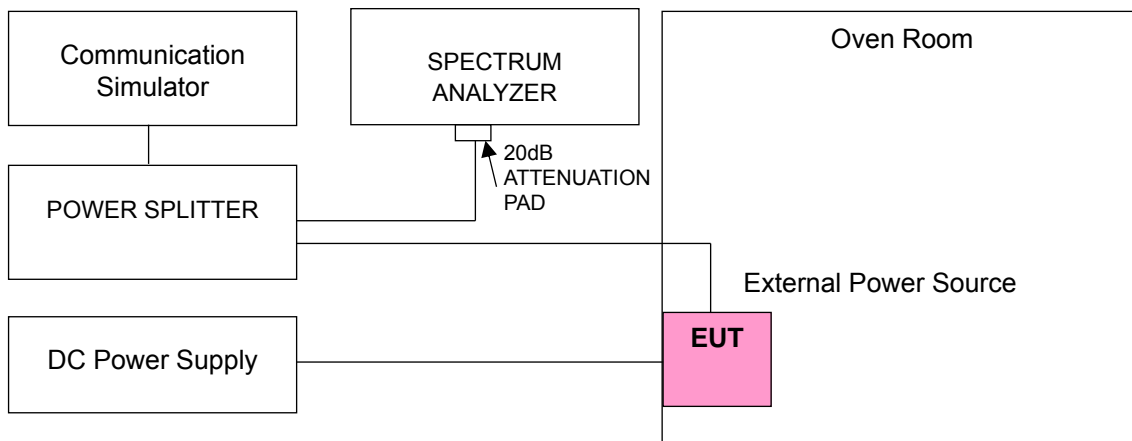

4.3.4 Test Results

Frequency Error vs. Voltage

Voltage (Volts)	WCDMA Band 4			
	Low Channel		High Channel	
	Frequency (MHz)	Frequency Error (ppm)	Frequency (MHz)	Frequency Error (ppm)
3.8	1712.400002	0.001	1752.600002	0.001
3.6	1712.400002	0.001	1752.600001	0.001
4.35	1712.400001	0.001	1752.600004	0.002

Note: The applicant defined the normal working voltage is from 3.6Vdc to 4.35Vdc.

Frequency Error vs. Temperature

Temp. (°C)	WCDMA Band 4			
	Low Channel		High Channel	
	Frequency (MHz)	Frequency Error (ppm)	Frequency (MHz)	Frequency Error (ppm)
-30	1712.400000	0.000	1752.600002	0.001
-20	1712.400000	0.000	1752.600003	0.002
-10	1712.400003	0.002	1752.600002	0.001
0	1712.400002	0.001	1752.600002	0.001
10	1712.400003	0.002	1752.600002	0.001
20	1712.399997	-0.002	1752.599997	-0.002
30	1712.399998	-0.001	1752.599996	-0.002
40	1712.399999	-0.001	1752.599996	-0.002
50	1712.399996	-0.002	1752.599999	-0.001
60	1712.400000	0.000	1752.599998	-0.001

Frequency Error vs. Voltage

Voltage (Volts)	LTE Band 4			
	Channel Bandwidth: 1.4 MHz			
	Low Channel		High Channel	
	Frequency (MHz)	Frequency Error (ppm)	Frequency (MHz)	Frequency Error (ppm)
3.8	1710.700002	0.001	1754.300001	0.001
3.6	1710.700003	0.002	1754.300004	0.002
4.35	1710.700002	0.001	1754.300001	0.001

Note: The applicant defined the normal working voltage is from 3.6Vdc to 4.35Vdc.

Frequency Error vs. Temperature

Temp. (°C)	LTE Band 4			
	Channel Bandwidth: 1.4 MHz			
	Low Channel		High Channel	
	Frequency (MHz)	Frequency Error (ppm)	Frequency (MHz)	Frequency Error (ppm)
-30	1710.700000	0.000	1754.300002	0.001
-20	1710.700000	0.000	1754.300002	0.001
-10	1710.700001	0.001	1754.300004	0.002
0	1710.700002	0.001	1754.300003	0.002
10	1710.700001	0.001	1754.300001	0.001
20	1710.699998	-0.001	1754.299997	-0.002
30	1710.699997	-0.002	1754.299999	-0.001
40	1710.699996	-0.002	1754.299996	-0.002
50	1710.699999	-0.001	1754.299999	-0.001
60	1710.700000	0.000	1754.299999	-0.001

Frequency Error vs. Voltage

Voltage (Volts)	LTE Band 4			
	Channel Bandwidth: 3 MHz			
	Low Channel		High Channel	
	Frequency (MHz)	Frequency Error (ppm)	Frequency (MHz)	Frequency Error (ppm)
3.8	1711.500001	0.001	1753.500002	0.001
3.6	1711.500002	0.001	1753.500001	0.001
4.35	1711.500002	0.001	1753.500004	0.002

Note: The applicant defined the normal working voltage is from 3.6Vdc to 4.35Vdc.

Frequency Error vs. Temperature

Temp. (°C)	LTE Band 4			
	Channel Bandwidth: 3 MHz			
	Low Channel		High Channel	
	Frequency (MHz)	Frequency Error (ppm)	Frequency (MHz)	Frequency Error (ppm)
-30	1711.500000	0.000	1753.500002	0.001
-20	1711.500000	0.000	1753.500004	0.002
-10	1711.500003	0.002	1753.500001	0.001
0	1711.500003	0.002	1753.500004	0.002
10	1711.500004	0.002	1753.500004	0.002
20	1711.499996	-0.002	1753.499998	-0.001
30	1711.499997	-0.002	1753.499999	-0.001
40	1711.499997	-0.002	1753.499998	-0.001
50	1711.499999	-0.001	1753.499998	-0.001
60	1711.500000	0.000	1753.499999	-0.001

Frequency Error vs. Voltage

Voltage (Volts)	LTE Band 4			
	Channel Bandwidth: 5 MHz			
	Low Channel		High Channel	
	Frequency (MHz)	Frequency Error (ppm)	Frequency (MHz)	Frequency Error (ppm)
3.8	1712.500003	0.002	1752.500002	0.001
3.6	1712.500003	0.002	1752.500003	0.002
4.35	1712.500003	0.002	1752.500001	0.001

Note: The applicant defined the normal working voltage is from 3.6Vdc to 4.35Vdc.

Frequency Error vs. Temperature

Temp. (°C)	LTE Band 4			
	Channel Bandwidth: 5 MHz			
	Low Channel		High Channel	
	Frequency (MHz)	Frequency Error (ppm)	Frequency (MHz)	Frequency Error (ppm)
-30	1712.500000	0.000	1752.500002	0.001
-20	1712.500000	0.000	1752.500003	0.002
-10	1712.500003	0.002	1752.500003	0.002
0	1712.500002	0.001	1752.500001	0.001
10	1712.500003	0.002	1752.500001	0.001
20	1712.499998	-0.001	1752.499997	-0.002
30	1712.499996	-0.002	1752.499999	-0.001
40	1712.499998	-0.001	1752.499998	-0.001
50	1712.499998	-0.001	1752.499999	-0.001
60	1712.500000	0.000	1752.499999	-0.001

Frequency Error vs. Voltage

Voltage (Volts)	LTE Band 4			
	Channel Bandwidth: 10 MHz			
	Low Channel		High Channel	
	Frequency (MHz)	Frequency Error (ppm)	Frequency (MHz)	Frequency Error (ppm)
3.8	1715.000003	0.002	1750.000003	0.002
3.6	1715.000002	0.001	1750.000001	0.001
4.35	1715.000001	0.001	1750.000002	0.001

Note: The applicant defined the normal working voltage is from 3.6Vdc to 4.35Vdc.

Frequency Error vs. Temperature

Temp. (°C)	LTE Band 4			
	Channel Bandwidth: 10 MHz			
	Low Channel		High Channel	
	Frequency (MHz)	Frequency Error (ppm)	Frequency (MHz)	Frequency Error (ppm)
-30	1715.000000	0.000	1750.000004	0.002
-20	1715.000000	0.000	1750.000001	0.001
-10	1715.000001	0.001	1750.000003	0.002
0	1715.000003	0.002	1750.000002	0.001
10	1715.000003	0.002	1750.000003	0.002
20	1714.999998	-0.001	1749.999997	-0.002
30	1714.999998	-0.001	1749.999997	-0.002
40	1714.999999	-0.001	1749.999997	-0.002
50	1714.999996	-0.002	1749.999998	-0.001
60	1714.999998	-0.001	1749.999997	-0.002

Frequency Error vs. Voltage

Voltage (Volts)	LTE Band 4			
	Channel Bandwidth: 15 MHz			
	Low Channel		High Channel	
	Frequency (MHz)	Frequency Error (ppm)	Frequency (MHz)	Frequency Error (ppm)
3.8	1717.500003	0.001	1747.500004	0.002
3.6	1717.500002	0.001	1747.500002	0.001
4.35	1717.500002	0.001	1747.500003	0.002

Note: The applicant defined the normal working voltage is from 3.6Vdc to 4.35Vdc.

Frequency Error vs. Temperature

Temp. (°C)	LTE Band 4			
	Channel Bandwidth: 15 MHz			
	Low Channel		High Channel	
	Frequency (MHz)	Frequency Error (ppm)	Frequency (MHz)	Frequency Error (ppm)
-30	1717.500000	0.000	1747.500003	0.002
-20	1717.500000	0.000	1747.500003	0.002
-10	1717.500002	0.001	1747.500003	0.002
0	1717.500002	0.001	1747.500004	0.002
10	1717.500003	0.002	1747.500002	0.001
20	1717.499998	-0.001	1747.499997	-0.002
30	1717.499997	-0.002	1747.499997	-0.002
40	1717.499998	-0.001	1747.499999	-0.001
50	1717.499998	-0.001	1747.499997	-0.002
60	1717.500000	0.000	1747.499997	-0.002

Frequency Error vs. Voltage

Voltage (Volts)	LTE Band 4			
	Channel Bandwidth: 20 MHz			
	Low Channel		High Channel	
	Frequency (MHz)	Frequency Error (ppm)	Frequency (MHz)	Frequency Error (ppm)
3.8	1720.000002	0.001	1745.000004	0.002
3.6	1720.000003	0.002	1745.000001	0.001
4.35	1720.000001	0.001	1745.000002	0.001

Note: The applicant defined the normal working voltage is from 3.6Vdc to 4.35Vdc.

Frequency Error vs. Temperature

Temp. (°C)	LTE Band 4			
	Channel Bandwidth: 20 MHz			
	Low Channel		High Channel	
	Frequency (MHz)	Frequency Error (ppm)	Frequency (MHz)	Frequency Error (ppm)
-30	1720.000000	0.000	1745.000003	0.002
-20	1720.000000	0.000	1745.000003	0.001
-10	1720.000003	0.002	1745.000003	0.001
0	1720.000002	0.001	1745.000003	0.002
10	1720.000003	0.002	1745.000002	0.001
20	1719.999997	-0.002	1744.999997	-0.002
30	1719.999996	-0.002	1744.999997	-0.001
40	1719.999999	-0.001	1744.999998	-0.001
50	1719.999996	-0.002	1744.999997	-0.002
60	1720.000000	0.000	1744.999997	-0.002

Frequency Error vs. Voltage

Voltage (Volts)	LTE Band 7			
	Channel Bandwidth: 5 MHz			
	Low Channel		High Channel	
	Frequency (MHz)	Frequency Error (ppm)	Frequency (MHz)	Frequency Error (ppm)
3.8	2502.500003	0.001	2567.500002	0.001
3.6	2502.500002	0.001	2567.500002	0.001
4.35	2502.500003	0.001	2567.500002	0.001

Note: The applicant defined the normal working voltage is from 3.6Vdc to 4.35Vdc.

Frequency Error vs. Temperature

Temp. (°C)	LTE Band 7			
	Channel Bandwidth: 5 MHz			
	Low Channel		High Channel	
	Frequency (MHz)	Frequency Error (ppm)	Frequency (MHz)	Frequency Error (ppm)
-30	2502.500000	0.000	2567.500001	0.000
-20	2502.500000	0.000	2567.500003	0.001
-10	2502.500004	0.002	2567.500003	0.001
0	2502.500002	0.001	2567.500003	0.001
10	2502.500003	0.001	2567.500001	0.001
20	2502.499996	-0.002	2567.499996	-0.001
30	2502.499998	-0.001	2567.499999	-0.001
40	2502.499999	0.000	2567.499998	-0.001
50	2502.499997	-0.001	2567.499997	-0.001
60	2502.500000	0.000	2567.499997	-0.001

Frequency Error vs. Voltage

Voltage (Volts)	LTE Band 7			
	Channel Bandwidth: 10 MHz			
	Low Channel		High Channel	
	Frequency (MHz)	Frequency Error (ppm)	Frequency (MHz)	Frequency Error (ppm)
3.8	2505.000003	0.001	2565.000002	0.001
3.6	2505.000002	0.001	2565.000002	0.001
4.35	2505.000001	0.001	2565.000004	0.001

Note: The applicant defined the normal working voltage is from 3.6Vdc to 4.35Vdc.

Frequency Error vs. Temperature

Temp. (°C)	LTE Band 7			
	Channel Bandwidth: 10 MHz			
	Low Channel		High Channel	
	Frequency (MHz)	Frequency Error (ppm)	Frequency (MHz)	Frequency Error (ppm)
-30	2505.000000	0.000	2565.000003	0.001
-20	2505.000000	0.000	2565.000002	0.001
-10	2505.000002	0.001	2565.000003	0.001
0	2505.000002	0.001	2565.000004	0.001
10	2505.000002	0.001	2565.000002	0.001
20	2504.999999	0.000	2564.999996	-0.002
30	2504.999996	-0.002	2564.999998	-0.001
40	2504.999998	-0.001	2564.999997	-0.001
50	2504.999999	0.000	2564.999997	-0.001
60	2505.000000	0.000	2564.999996	-0.001

Frequency Error vs. Voltage

Voltage (Volts)	LTE Band 7			
	Channel Bandwidth: 15 MHz			
	Low Channel		High Channel	
	Frequency (MHz)	Frequency Error (ppm)	Frequency (MHz)	Frequency Error (ppm)
3.8	2507.500001	0.001	2562.500004	0.001
3.6	2507.500002	0.001	2562.500001	0.000
4.35	2507.500002	0.001	2562.500002	0.001

Note: The applicant defined the normal working voltage is from 3.6Vdc to 4.35Vdc.

Frequency Error vs. Temperature

Temp. (°C)	LTE Band 7			
	Channel Bandwidth: 15 MHz			
	Low Channel		High Channel	
	Frequency (MHz)	Frequency Error (ppm)	Frequency (MHz)	Frequency Error (ppm)
-30	2507.500000	0.000	2562.500003	0.001
-20	2507.500000	0.000	2562.500001	0.000
-10	2507.500002	0.001	2562.500003	0.001
0	2507.500004	0.002	2562.500003	0.001
10	2507.500001	0.001	2562.500004	0.001
20	2507.499998	-0.001	2562.499996	-0.002
30	2507.499999	-0.001	2562.499997	-0.001
40	2507.499996	-0.002	2562.499997	-0.001
50	2507.499997	-0.001	2562.499998	-0.001
60	2507.500000	0.000	2562.499996	-0.001

Frequency Error vs. Voltage

Voltage (Volts)	LTE Band 7			
	Channel Bandwidth: 20 MHz			
	Low Channel		High Channel	
	Frequency (MHz)	Frequency Error (ppm)	Frequency (MHz)	Frequency Error (ppm)
3.8	2510.000004	0.001	2560.000004	0.002
3.6	2510.000001	0.000	2560.000002	0.001
4.35	2510.000001	0.000	2560.000004	0.001

Note: The applicant defined the normal working voltage is from 3.6Vdc to 4.35Vdc.

Frequency Error vs. Temperature

Temp. (°C)	LTE Band 7			
	Channel Bandwidth: 20 MHz			
	Low Channel		High Channel	
	Frequency (MHz)	Frequency Error (ppm)	Frequency (MHz)	Frequency Error (ppm)
-30	2510.000000	0.000	2560.000002	0.001
-20	2510.000000	0.000	2560.000002	0.001
-10	2510.000001	0.000	2560.000002	0.001
0	2510.000002	0.001	2560.000002	0.001
10	2510.000001	0.000	2560.000002	0.001
20	2509.999997	-0.001	2559.999997	-0.001
30	2509.999997	-0.001	2559.999997	-0.001
40	2509.999999	0.000	2559.999998	-0.001
50	2509.999998	-0.001	2559.999998	-0.001
60	2510.000000	0.000	2559.999998	-0.001

4.4 Emission Bandwidth Measurement

4.4.1 Limits of Emission Bandwidth Measurement

According to FCC 27.53(m)(6) specified that emission bandwidth is defined as the width of the signal between two points, one below the carrier center frequency and one above the carrier center frequency, outside of which all emissions are attenuated at least 26dB below the transmitter power.

4.4.2 Test Procedure

The transmitter output was connected to the spectrum analyzer through an attenuator. The bandwidth of the fundamental frequency was measured by spectrum analyzer with RBW = 51kHz and VBW = 150kHz for WCDMA; with RBW = 30kHz and VBW = 100kHz (Channel Bandwidth: 1.4MHz), RBW = 62kHz and VBW = 200kHz (Channel Bandwidth: 3MHz), RBW = 100kHz and VBW = 300kHz (Channel Bandwidth: 5MHz), RBW = 200kHz and VBW = 1MHz (Channel Bandwidth: 10MHz), RBW = 300kHz and VBW = 1MHz (Channel Bandwidth: 15MHz) and RBW = 430kHz and VBW = 1.3MHz (Channel Bandwidth: 20MHz) for LTE Band 4, 7, 38; RBW = 51kHz and VBW = 150kHz (Channel Bandwidth: 5MHz), RBW = 100kHz and VBW = 300kHz (Channel Bandwidth: 10MHz), RBW = 200kHz and VBW = 620kHz (Channel Bandwidth: 15MHz) and RBW = 430kHz and VBW = 1.2MHz (Channel Bandwidth: 20MHz) for LTE Band 41. The 26dB bandwidth is defined as the total spectrum the power of which is higher than peak power minus 26dB.

4.4.3 Test Setup

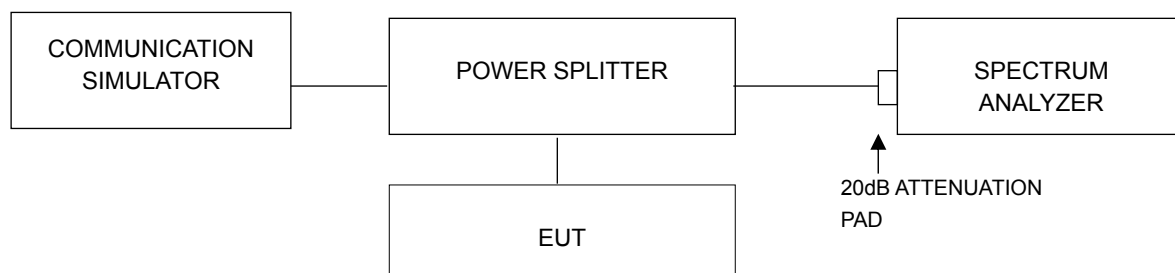

4.4.4 Test Result

Occupied Bandwidth WCDMA Band 4

Channel	Frequency (MHz)	99% Occupied Bandwidth (MHz)		
		WCDMA	HSDPA	HSUPA
1312	1712.4	4.11	4.13	4.13
1413	1732.6	4.13	4.15	4.13
1513	1752.6	4.15	4.11	4.13

Spectrum Plot of Worst Value

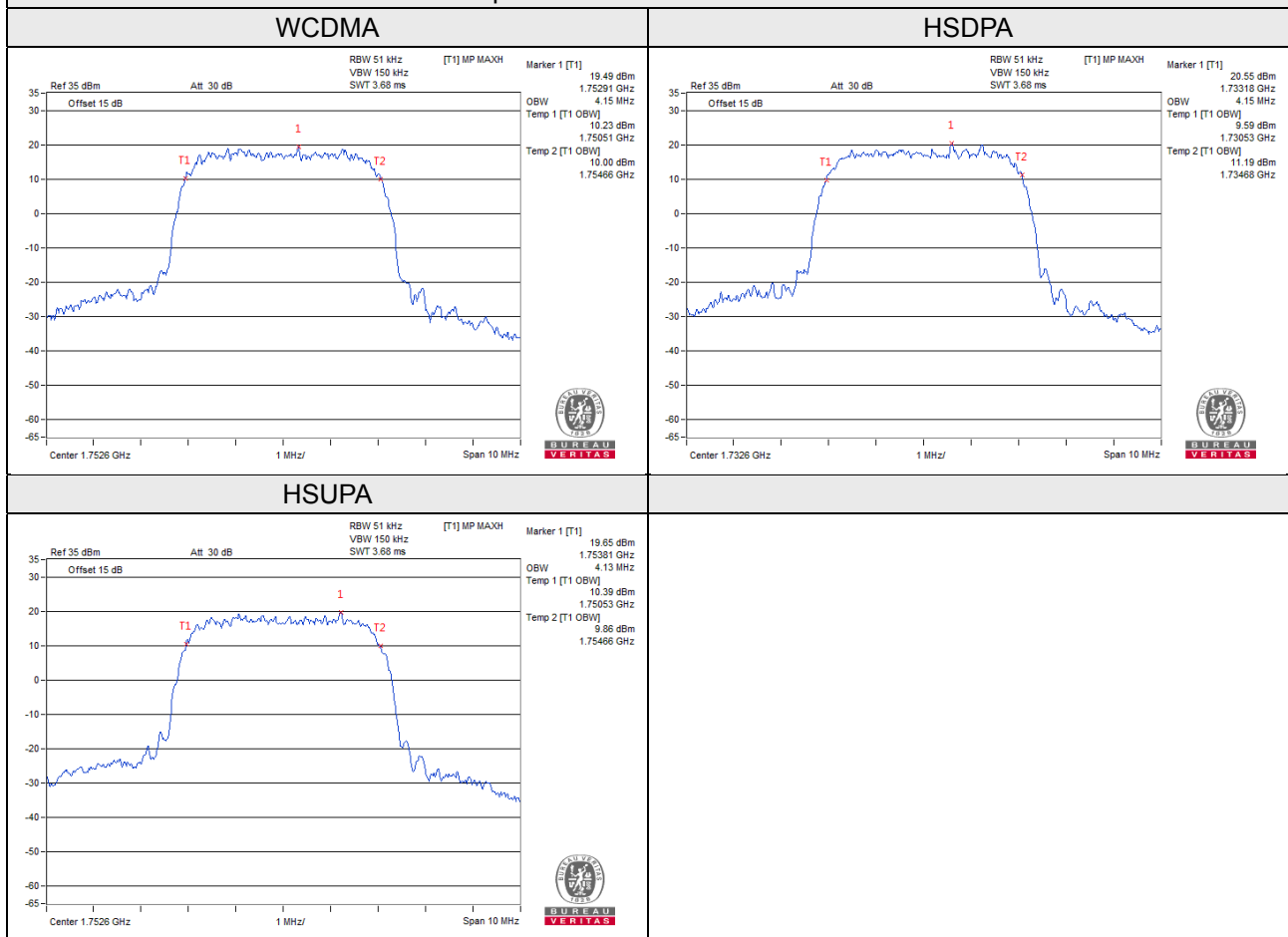

LTE Band 4

LTE Band 4, Channel Bandwidth 1.4MHz				
Channel	Frequency (MHz)	99% Occupied Bandwidth (MHz)		
		QPSK	16QAM	64QAM
19957	1710.7	1.09	1.09	1.09
20175	1732.5	1.09	1.09	1.09
20393	1754.3	1.09	1.09	1.09
LTE Band 4, Channel Bandwidth 3MHz				
Channel	Frequency (MHz)	99% Occupied Bandwidth (MHz)		
		QPSK	16QAM	64QAM
19965	1711.5	2.70	2.70	2.70
20175	1732.5	2.70	2.70	2.70
20385	1753.5	2.70	2.70	2.70
LTE Band 4, Channel Bandwidth 5MHz				
Channel	Frequency (MHz)	99% Occupied Bandwidth (MHz)		
		QPSK	16QAM	64QAM
19975	1712.5	4.49	4.49	4.49
20175	1732.5	4.49	4.49	4.49
20375	1752.5	4.49	4.49	4.49
LTE Band 4, Channel Bandwidth 10MHz				
Channel	Frequency (MHz)	99% Occupied Bandwidth (MHz)		
		QPSK	16QAM	64QAM
20000	1715.0	8.95	8.96	8.95
20175	1732.5	8.95	8.96	8.95
20350	1750.0	8.95	8.95	8.94
LTE Band 4, Channel Bandwidth 15MHz				
Channel	Frequency (MHz)	99% Occupied Bandwidth (MHz)		
		QPSK	16QAM	64QAM
20025	1717.5	13.43	13.42	13.41
20175	1732.5	13.43	13.43	13.42
20325	1747.5	13.42	13.41	13.41

LTE Band 4, Channel Bandwidth 20MHz

Channel	Frequency (MHz)	99% Occupied Bandwidth (MHz)		
		QPSK	16QAM	64QAM
20050	1720.0	17.88	17.90	17.90
20175	1732.5	17.89	17.92	17.91
20300	1745.0	17.87	17.89	17.89

Spectrum Plot of Worst Value

1.4MHz / 16QAM

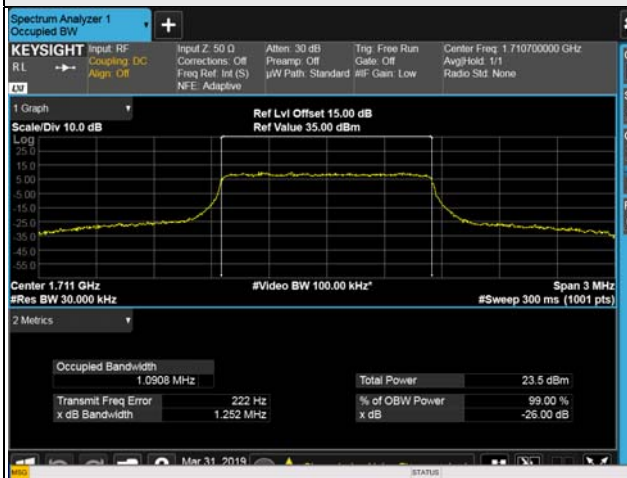

3MHz / 64QAM



5MHz / 16QAM

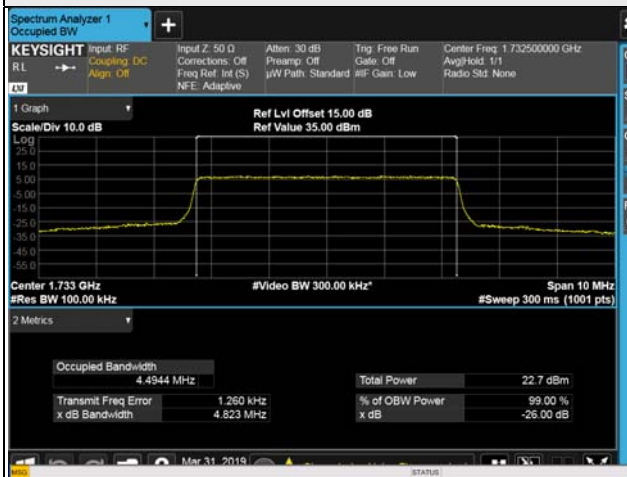

10MHz / 16QAM



15MHz / QPSK



20MHz / 16QAM



LTE Band 7

LTE Band 7, Channel Bandwidth 5MHz				
Channel	Frequency (MHz)	99% Occupied Bandwidth (MHz)		
		QPSK	16QAM	64QAM
20775	2502.5	4.49	4.49	4.49
21100	2535.0	4.49	4.49	4.50
21425	2567.5	4.49	4.49	4.49
LTE Band 7, Channel Bandwidth 10MHz				
Channel	Frequency (MHz)	99% Occupied Bandwidth (MHz)		
		QPSK	16QAM	64QAM
20800	2505.0	8.95	8.95	8.95
21100	2535.0	8.95	8.96	8.96
21400	2565.0	8.95	8.95	8.94
LTE Band 7, Channel Bandwidth 15MHz				
Channel	Frequency (MHz)	99% Occupied Bandwidth (MHz)		
		QPSK	16QAM	64QAM
20825	2507.5	13.44	13.43	13.43
21100	2535.0	13.44	13.43	13.43
21375	2562.5	13.42	13.41	13.40
LTE Band 7, Channel Bandwidth 20MHz				
Channel	Frequency (MHz)	99% Occupied Bandwidth (MHz)		
		QPSK	16QAM	64QAM
20850	2510.0	17.89	17.91	17.91
21100	2535.0	17.89	17.91	17.92
21350	2560.0	17.86	17.88	17.88

Spectrum Plot of Worst Value

5MHz / 64QAM



10MHz / 16QAM



15MHz / QPSK



20MHz / 64QAM



26dB Bandwidth
WCDMA Band 4

Channel	Frequency (MHz)	26dB Bandwidth (MHz)		
		WCDMA	HSDPA	HSUPA
1312	1712.4	4.67	4.70	4.69
1413	1732.6	4.70	4.69	4.66
1513	1752.6	4.69	4.69	4.69

Spectrum Plot of Worst Value

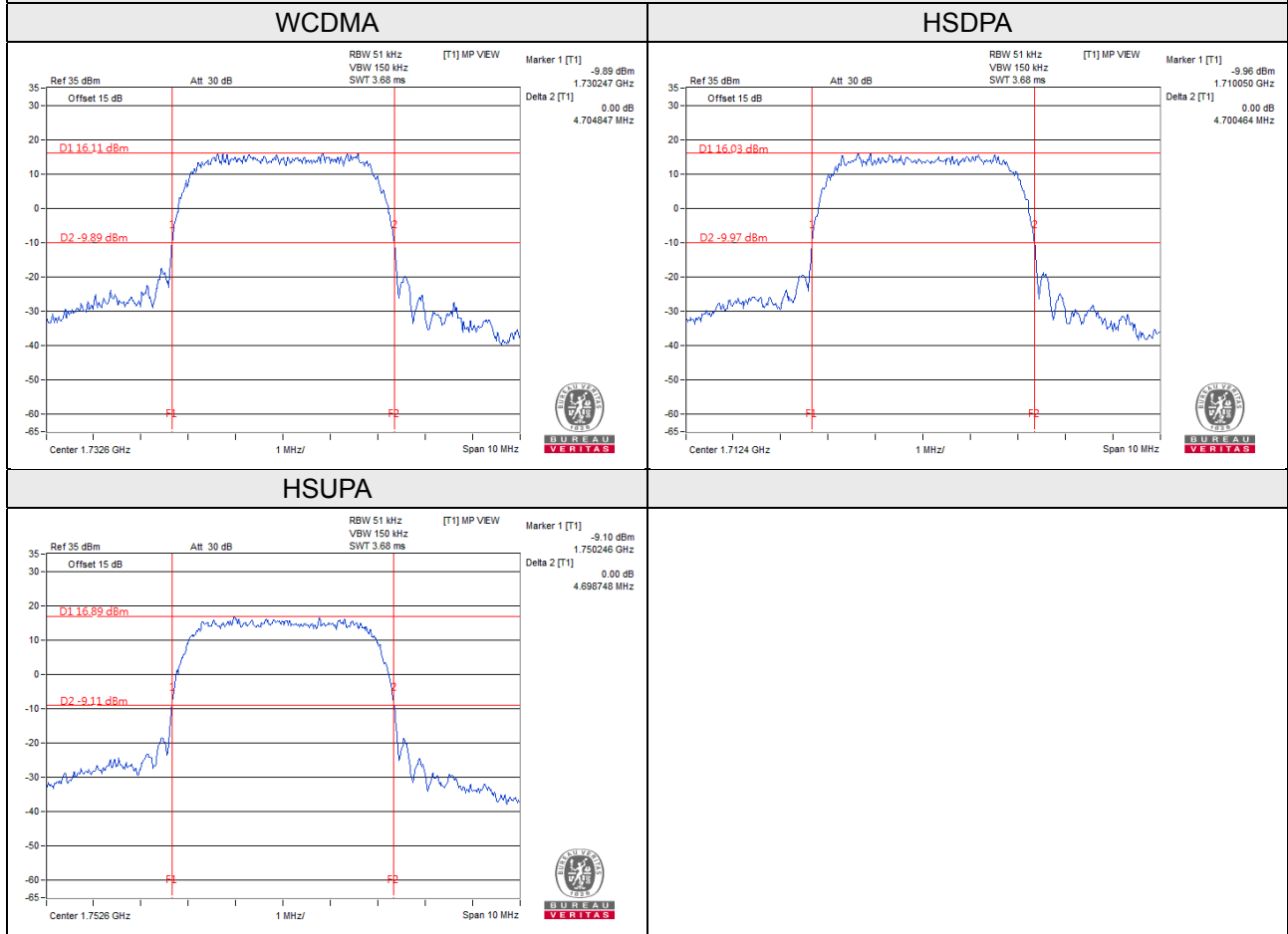

LTE Band 4

LTE Band 4, Channel Bandwidth 1.4MHz				
Channel	Frequency (MHz)	26dB Bandwidth (MHz)		
		QPSK	16QAM	64QAM
19957	1710.7	1.25	1.25	1.26
20175	1732.5	1.25	1.25	1.25
20393	1754.3	1.25	1.25	1.25
LTE Band 4, Channel Bandwidth 3MHz				
Channel	Frequency (MHz)	26dB Bandwidth (MHz)		
		QPSK	16QAM	64QAM
19965	1711.5	2.92	2.93	2.92
20175	1732.5	2.91	2.93	2.91
20385	1753.5	2.91	2.92	2.92
LTE Band 4, Channel Bandwidth 5MHz				
Channel	Frequency (MHz)	26dB Bandwidth (MHz)		
		QPSK	16QAM	64QAM
19975	1712.5	4.83	4.83	4.84
20175	1732.5	4.82	4.82	4.84
20375	1752.5	4.81	4.83	4.83
LTE Band 4, Channel Bandwidth 10MHz				
Channel	Frequency (MHz)	26dB Bandwidth (MHz)		
		QPSK	16QAM	64QAM
20000	1715.0	9.52	9.51	9.52
20175	1732.5	9.52	9.51	9.53
20350	1750.0	9.49	9.51	9.52
LTE Band 4, Channel Bandwidth 15MHz				
Channel	Frequency (MHz)	26dB Bandwidth (MHz)		
		QPSK	16QAM	64QAM
20025	1717.5	14.23	14.23	14.24
20175	1732.5	14.22	14.22	14.24
20325	1747.5	14.21	14.23	14.22

LTE Band 4, Channel Bandwidth 20MHz

Channel	Frequency (MHz)	26dB Bandwidth (MHz)		
		QPSK	16QAM	64QAM
20050	1720.0	19.00	19.01	19.02
20175	1732.5	19.00	19.02	19.01
20300	1745.0	18.99	18.98	18.99

Spectrum Plot of Worst Value

1.4MHz / 64QAM

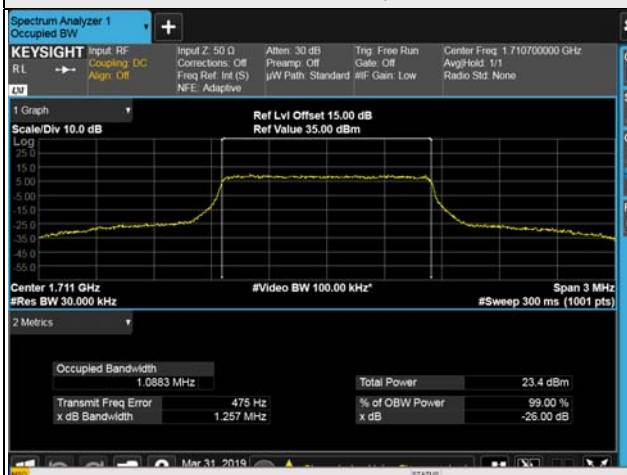

3MHz / 16QAM

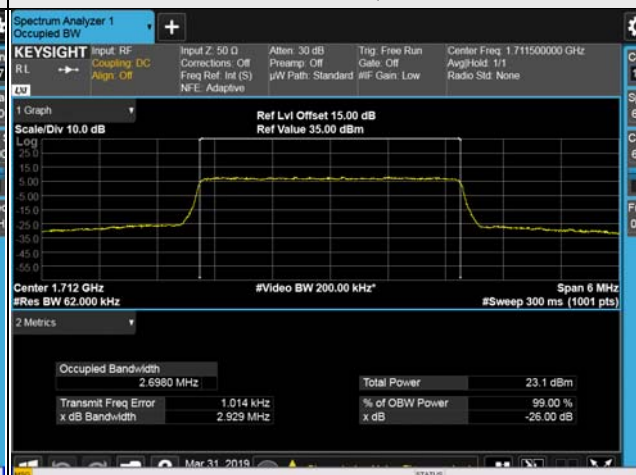

5MHz / 64QAM



10MHz / 64QAM



15MHz / 64QAM



20MHz / 16QAM



LTE Band 7

LTE Band 7, Channel Bandwidth 5MHz				
Channel	Frequency (MHz)	26dB Bandwidth (MHz)		
		QPSK	16QAM	64QAM
20775	2502.5	4.81	4.83	4.82
21100	2535.0	4.83	4.84	4.85
21425	2567.5	4.81	4.81	4.84
LTE Band 7, Channel Bandwidth 10MHz				
Channel	Frequency (MHz)	26dB Bandwidth (MHz)		
		QPSK	16QAM	64QAM
20800	2505.0	9.50	9.51	9.51
21100	2535.0	9.51	9.53	9.54
21400	2565.0	9.50	9.51	9.53
LTE Band 7, Channel Bandwidth 15MHz				
Channel	Frequency (MHz)	26dB Bandwidth (MHz)		
		QPSK	16QAM	64QAM
20825	2507.5	14.26	14.25	14.24
21100	2535.0	14.25	14.25	14.24
21375	2562.5	14.22	14.21	14.22
LTE Band 7, Channel Bandwidth 20MHz				
Channel	Frequency (MHz)	26dB Bandwidth (MHz)		
		QPSK	16QAM	64QAM
20850	2510.0	19.00	19.01	19.02
21100	2535.0	19.01	19.02	19.02
21350	2560.0	18.97	19.00	19.00

Spectrum Plot of Worst Value

5MHz / 64QAM

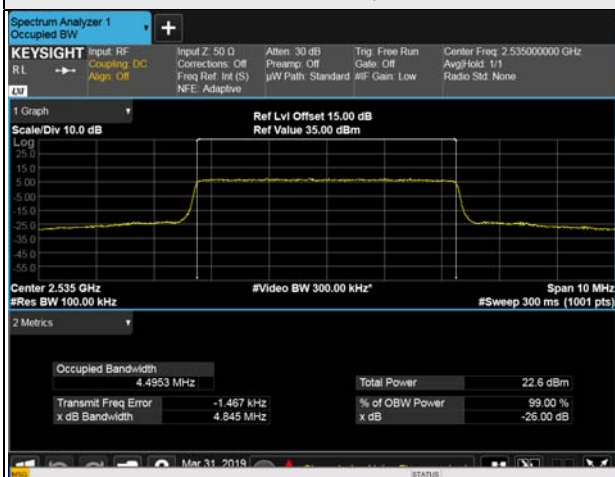

10MHz / 64QAM



15MHz / QPSK



20MHz / 64QAM



4.5 Channel Edge Measurement

4.5.1 Limits of Band Edge Measurement

For WCDMA Band 4, LTE Band 4

According to FCC 27.53(h) for operations in the 1695-1710 MHz, 1710-1755 MHz, 1755-1780 MHz, 1915-1920 MHz, 1995-2000 MHz, 2000-2020 MHz, 2110-2155 MHz, 2155-2180 MHz, and 2180-2200 bands, the power of any emission outside a licensee's frequency block shall be attenuated below the transmitter power (P) in watts by at least $43 + 10 \log (P)$ dB.

For LTE Band 7

According to FCC 27.53(m)(4) specified that power of any emission outside of the channel edge must be attenuated below the transmitting power (P) by a factor shall be not less than $40 + 10 \log (P)$ dB on all frequencies between the channel edge and 5 megahertz from the channel edge, $43 + 10 \log (P)$ dB on all frequencies between 5 megahertz and X megahertz from the channel edge, and $55 + 10 \log (P)$ dB on all frequencies more than X megahertz from the channel edge, where X is the greater of 6 megahertz or the actual emission bandwidth. In addition, the attenuation factor shall not be less that $43 + 10 \log (P)$ dB on all frequencies between 2490.5 MHz and 2496 MHz and $55 + 10 \log (P)$ dB at or below 2490.5 MHz. In the 1 MHz bands immediately outside and adjacent to the frequency block a resolution bandwidth of at least two percent may be employed, except when the 1 megahertz band is 2495-2496 MHz, in which case a resolution bandwidth of at least one percent may be employed.

4.5.2 Test Setup

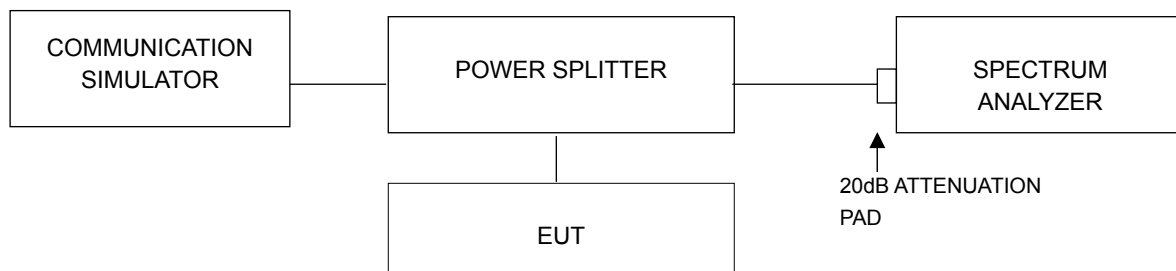

4.5.3 Test Procedures

- The EUT was set up for the rated peak power. The power was measured with Spectrum Analyzer. All measurements were done at 3 channels: low, middle and high operational frequency range.
- The center frequency of spectrum is the band edge frequency and span is 10MHz. RB of the spectrum is 51kHz and VB of the spectrum is 150kHz (WCDMA / HSDPA / HSUPA).
- The center frequency of spectrum is the band edge frequency and span is 1MHz. RB of the spectrum is 15kHz and VB of the spectrum is 51kHz (LTE Channel Bandwidth 1.4MHz).
- The center frequency of spectrum is the band edge frequency and span is 1MHz. RB of the spectrum is 30kHz and VB of the spectrum is 100kHz (LTE Channel Bandwidth 3MHz).
- The center frequency of spectrum is the band edge frequency and span is 1MHz. RB of the spectrum is 62kHz and VB of the spectrum is 200kHz (LTE Channel Bandwidth 5MHz).
- The center frequency of spectrum is the band edge frequency and span is 1MHz. RB of the spectrum is 100kHz and VB of the spectrum is 300kHz (LTE Channel Bandwidth 10MHz).
- The center frequency of spectrum is the band edge frequency and span is 1MHz. RB of the spectrum is 150kHz and VB of the spectrum is 470kHz (LTE Channel Bandwidth 15MHz).
- The center frequency of spectrum is the band edge frequency and span is 1MHz. RB of the spectrum is 200kHz and VB of the spectrum is 1MHz (LTE Channel Bandwidth 20MHz).
- Except WCDMA Band 4 and LTE Band 4, other LTE Band measurement procedure refer 27.53(m)(6).
- Record the max trace plot into the test report.

4.5.4 Test Results

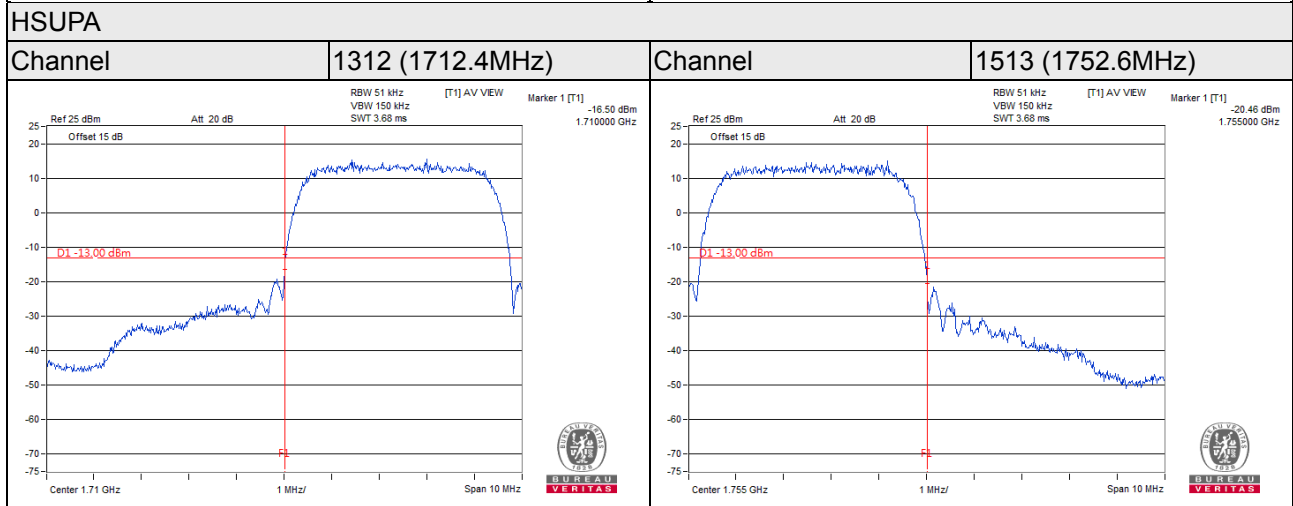
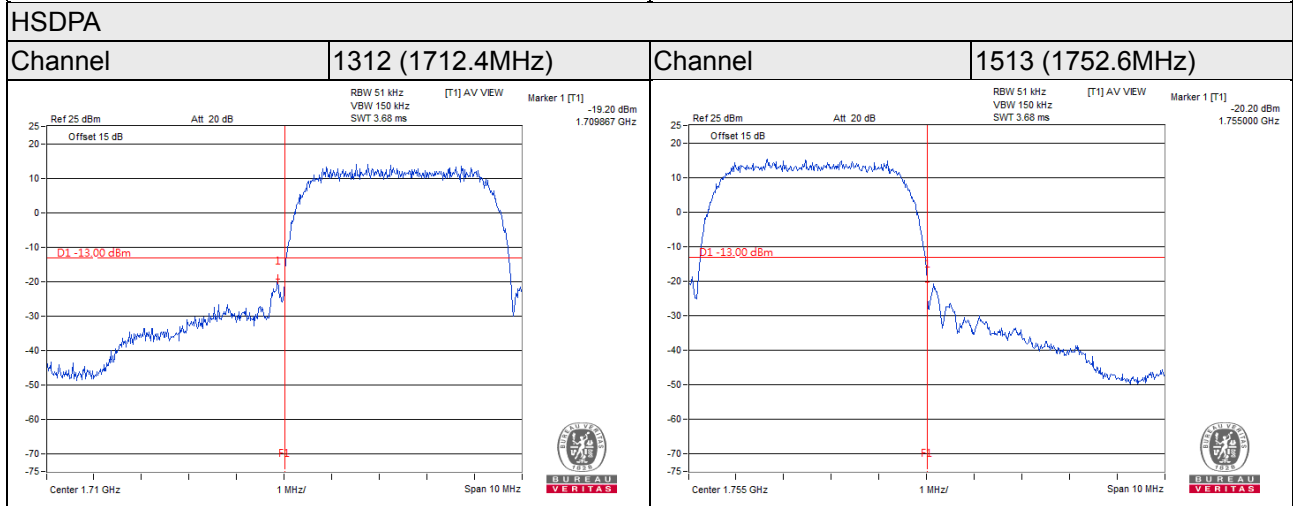
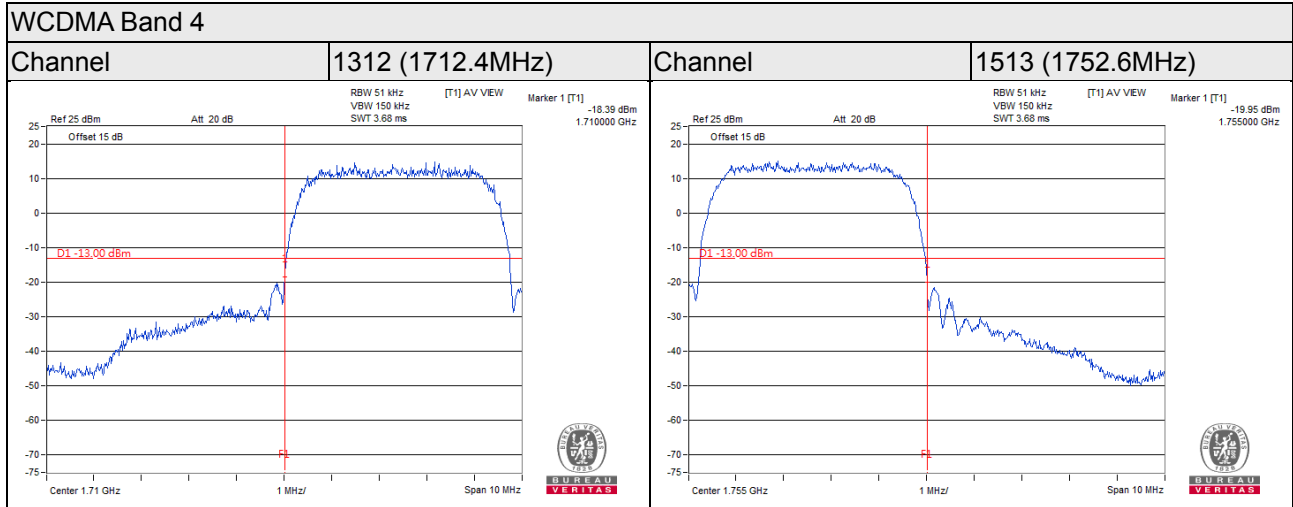

LTE Band 4

Channel Bandwidth: 1.4MHz

Channel 19957
(1710.7MHz)

QPSK

1 RB / 0 RB Offset

Channel 20393
(1754.3MHz)

QPSK

1 RB / 5 RB Offset

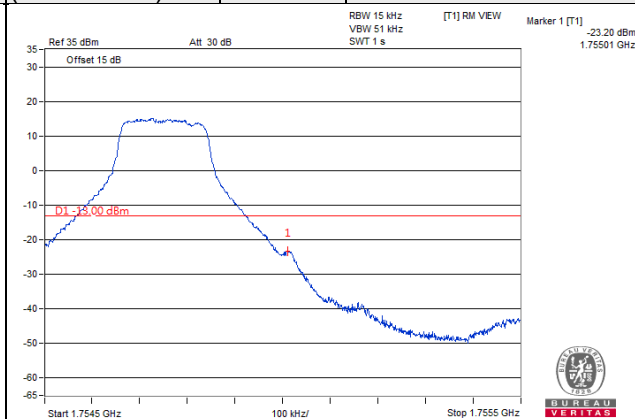
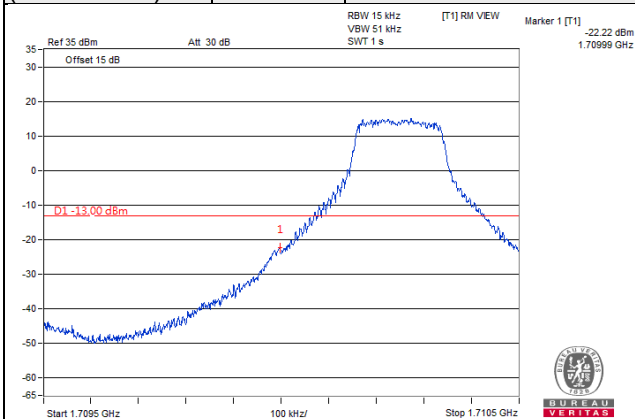

Channel 19957
(1710.7MHz)

QPSK

6 RB / 0 RB Offset

Channel 20393
(1754.3MHz)

QPSK

6 RB / 0 RB Offset

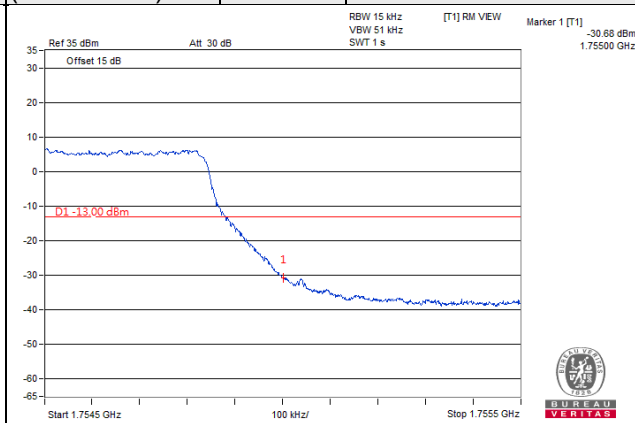
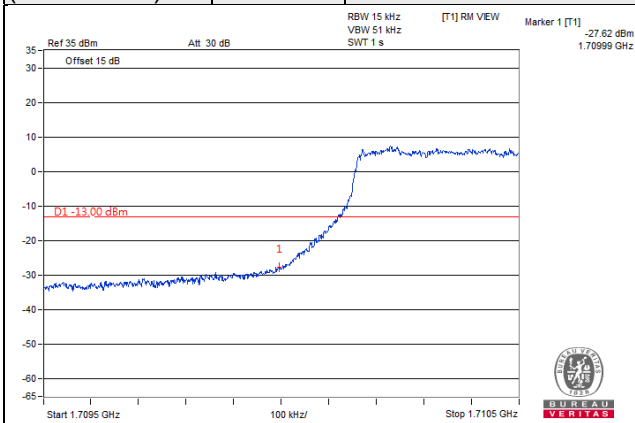

Channel Bandwidth: 3MHz

Channel 19965
(1711.5MHz)

QPSK

1 RB / 0 RB Offset

Channel 20385
(1753.5MHz)

QPSK

1 RB / 14 RB Offset

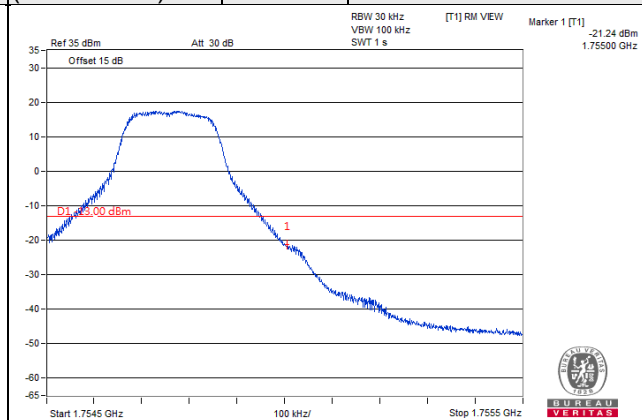
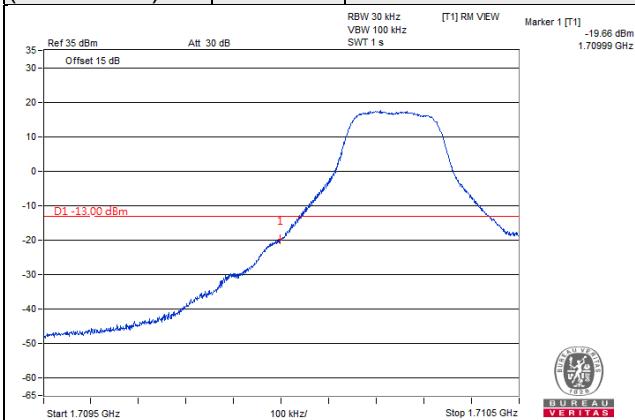

Channel 19965
(1711.5MHz)

QPSK

15 RB / 0 RB Offset

Channel 20385
(1753.5MHz)

QPSK

15 RB / 0 RB Offset

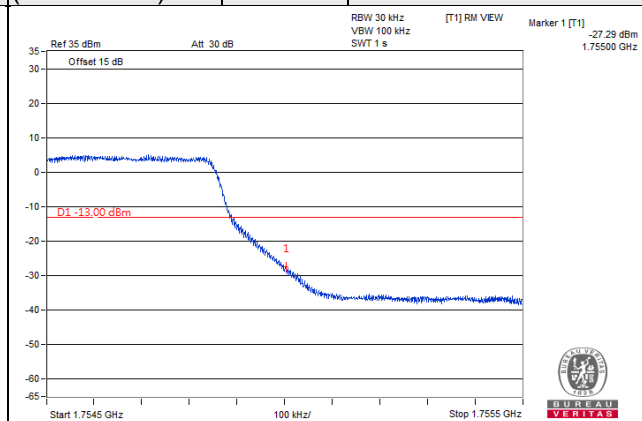
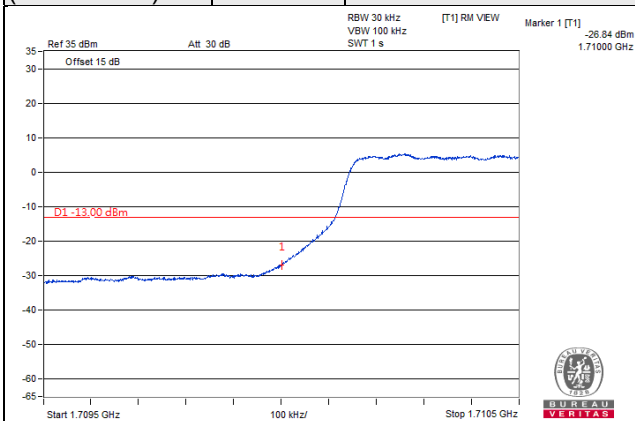

Channel Bandwidth: 5MHz

**Channel 19975
(1712.5MHz)**

QPSK

1 RB / 0 RB Offset

**Channel 20375
(1752.5MHz)**

QPSK

1 RB / 24 RB Offset

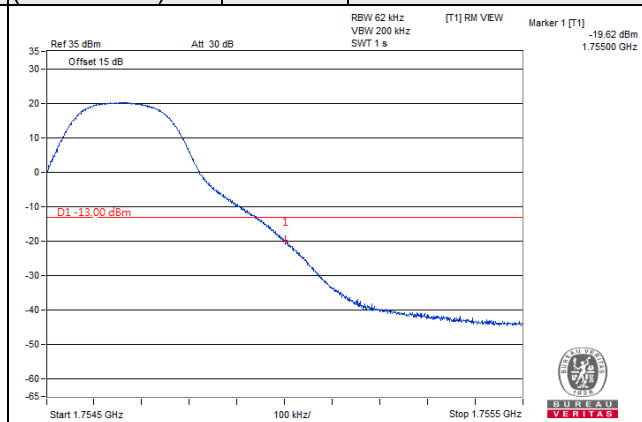
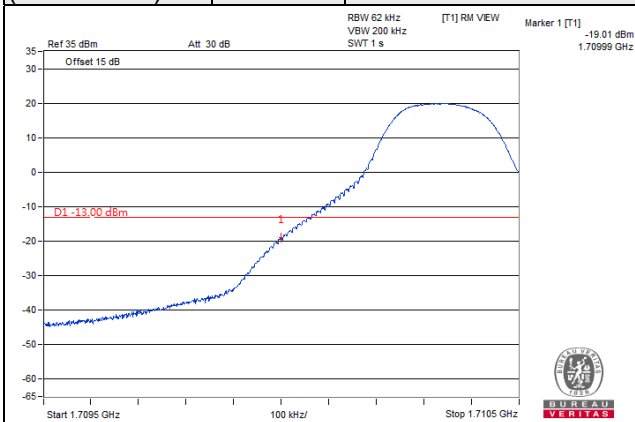

**Channel 19975
(1712.5MHz)**

QPSK

25 RB / 0 RB Offset

**Channel 20375
(1752.5MHz)**

QPSK

25 RB / 0 RB Offset

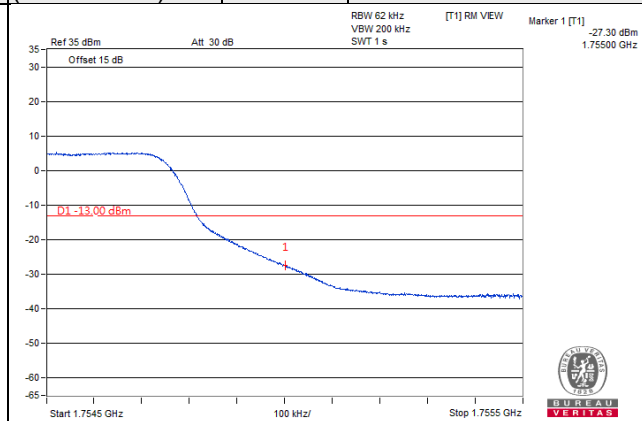
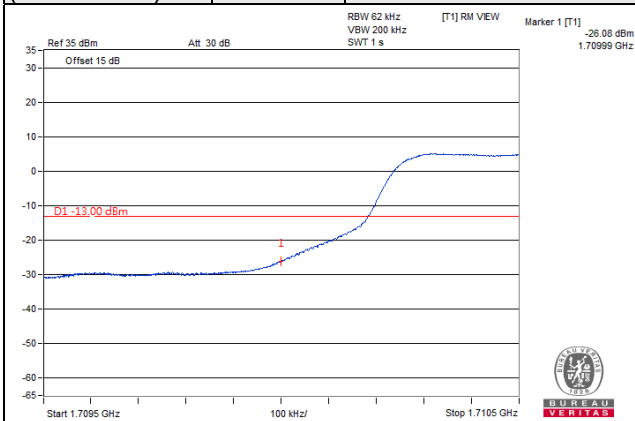

Channel Bandwidth: 10MHz

Channel 20000 (1715.0MHz)	QPSK	1 RB / 0 RB Offset	Channel 20350 (1750.0MHz)	QPSK	1 RB / 49 RB Offset
--------------------------------------	-------------	---------------------------	--------------------------------------	-------------	----------------------------

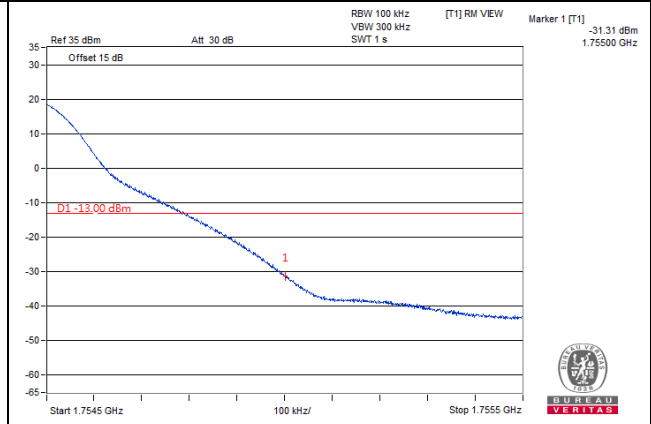
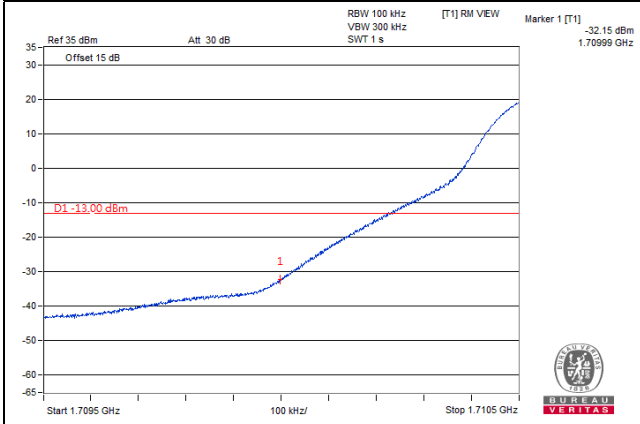

Channel 20000 (1715.0MHz)	QPSK	50 RB / 0 RB Offset	Channel 20350 (1750.0MHz)	QPSK	50 RB / 0 RB Offset
--------------------------------------	-------------	----------------------------	--------------------------------------	-------------	----------------------------

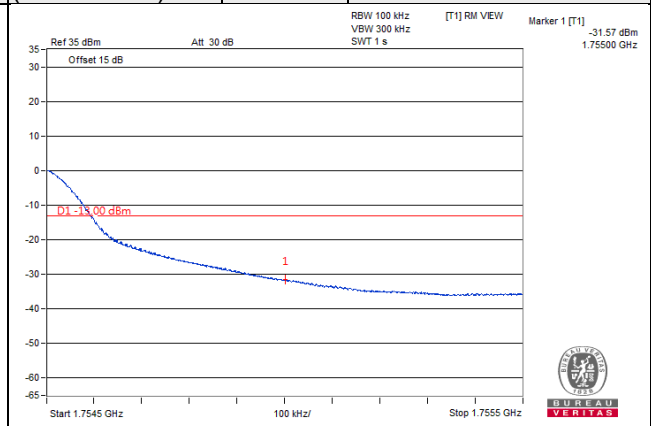
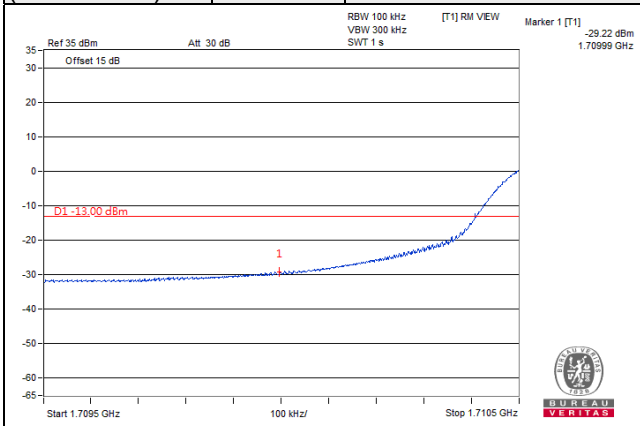

Channel Bandwidth: 15MHz

Channel 20025 (1717.5MHz)	QPSK	1 RB / 0 RB Offset	Channel 20325 (1747.5MHz)	QPSK	1 RB / 74 RB Offset
--------------------------------------	-------------	---------------------------	--------------------------------------	-------------	----------------------------

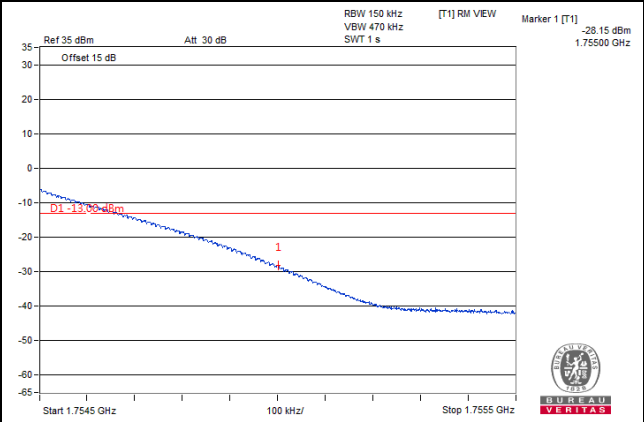
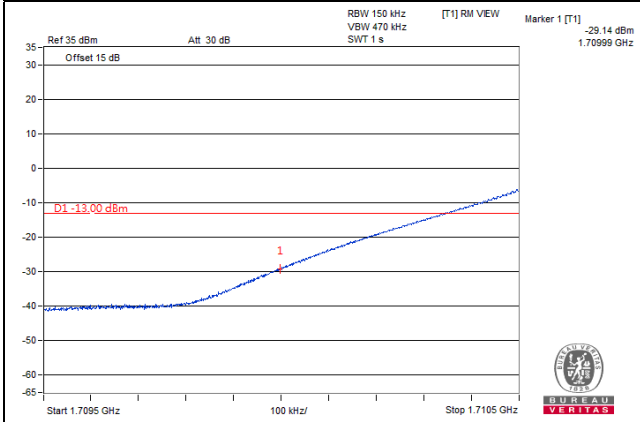

Channel 20025 (1717.5MHz)	QPSK	75 RB / 0 RB Offset	Channel 20325 (1747.5MHz)	QPSK	75 RB / 0 RB Offset
--------------------------------------	-------------	----------------------------	--------------------------------------	-------------	----------------------------

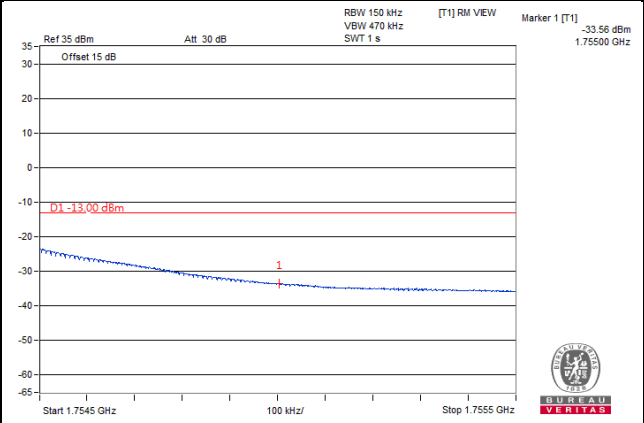
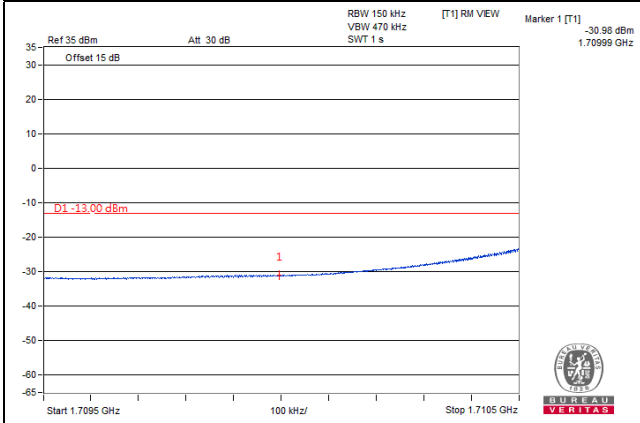

Channel Bandwidth: 20MHz

Channel 20050 (1720.0MHz)	QPSK	1 RB / 0 RB Offset	Channel 20300 (1745.0MHz)	QPSK	1 RB / 99 RB Offset
--------------------------------------	-------------	---------------------------	--------------------------------------	-------------	----------------------------

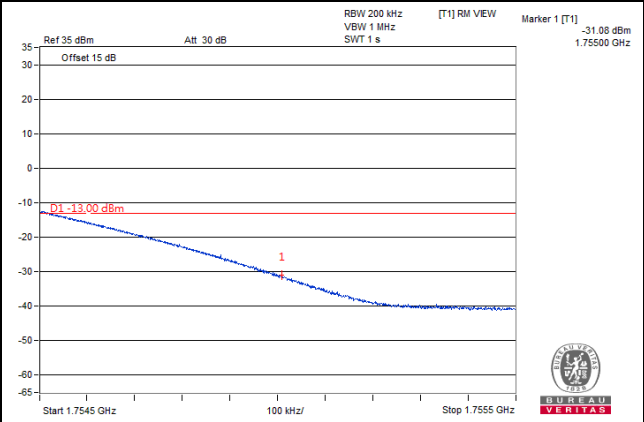
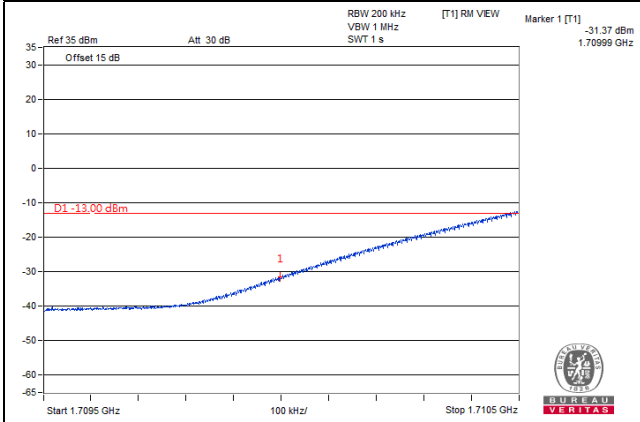

Channel 20050 (1720.0MHz)	QPSK	100 RB / 0 RB Offset	Channel 20300 (1745.0MHz)	QPSK	100 RB / 0 RB Offset
--------------------------------------	-------------	-----------------------------	--------------------------------------	-------------	-----------------------------

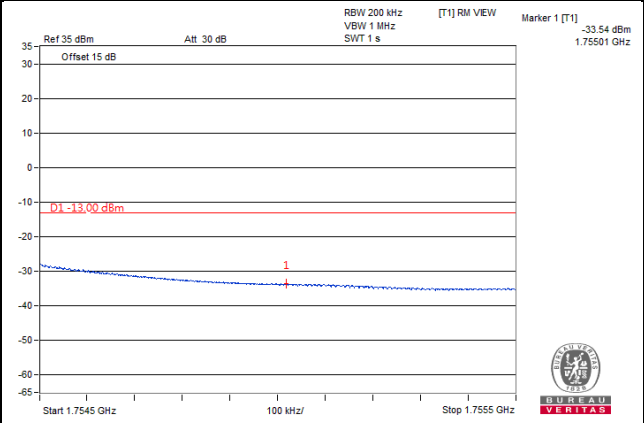
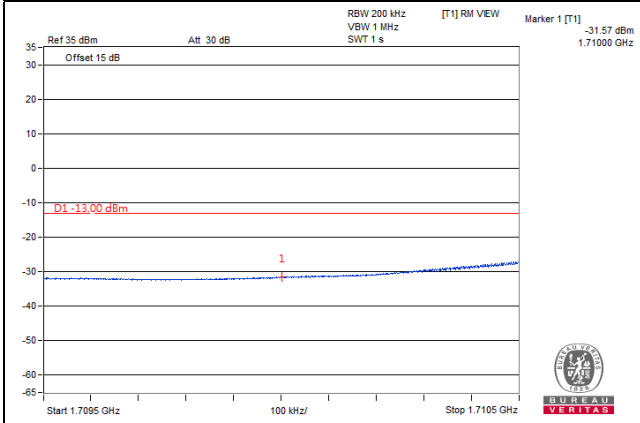

LTE Band 7

Channel Bandwidth: 5MHz

Channel 20775
(2502.5MHz)

QPSK

1 RB / 0 RB Offset

Channel 21425
(2567.5MHz)

QPSK

1 RB / 24 RB Offset

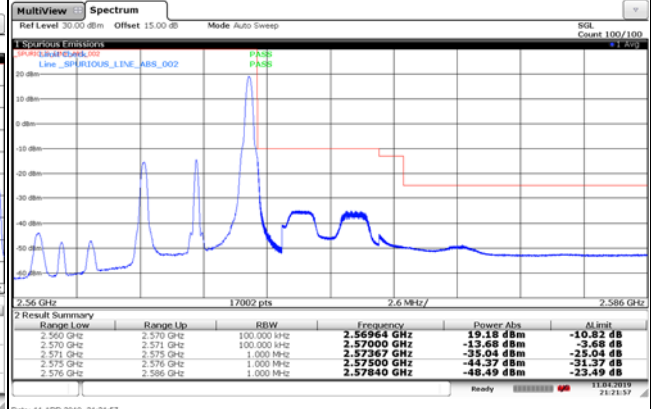
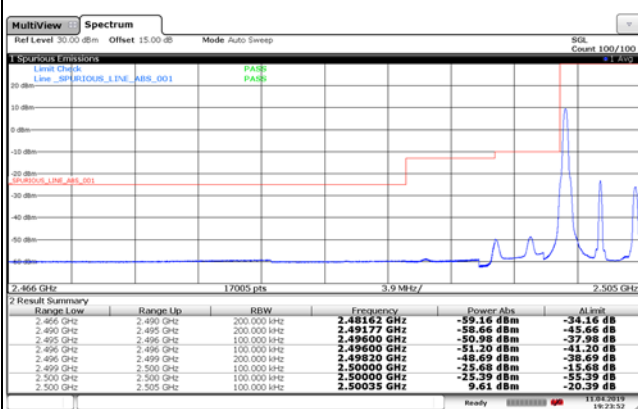

Channel 20775
(2502.5MHz)

QPSK

25 RB / 0 RB Offset

Channel 21425
(2567.5MHz)

QPSK

25 RB / 0 RB Offset

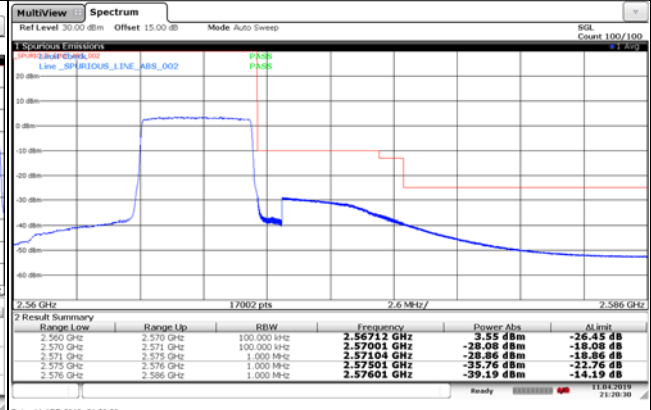
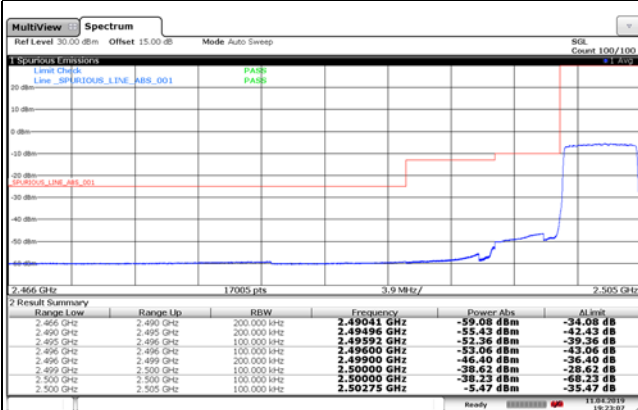

Channel Bandwidth: 10MHz

Channel 20800
(2505MHz)

QPSK

1 RB / 0 RB Offset

Channel 21400
(2565MHz)

QPSK

1 RB / 49RB Offset

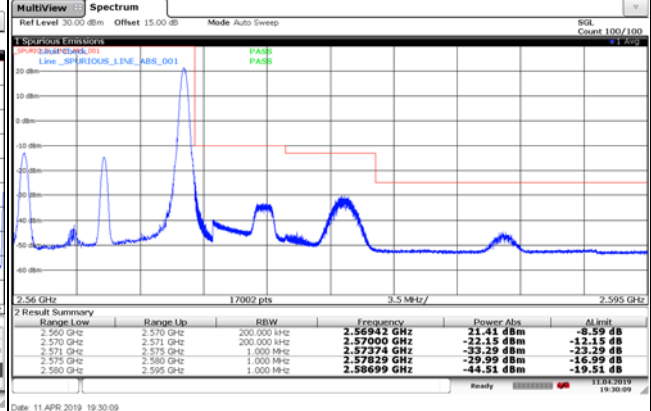
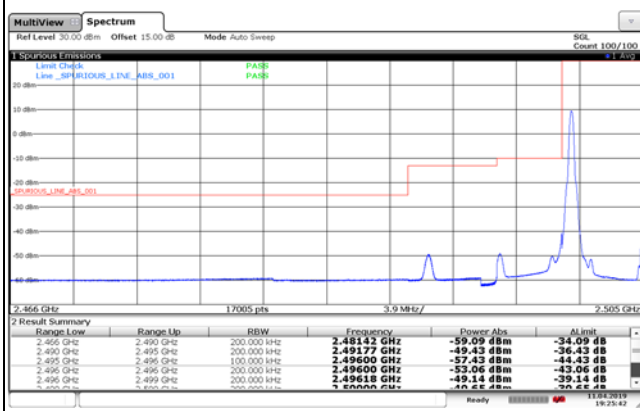

Channel 20800
(2505MHz)

QPSK

50 RB / 0 RB Offset

Channel 21400
(2565MHz)

QPSK

50 RB / 0 RB Offset

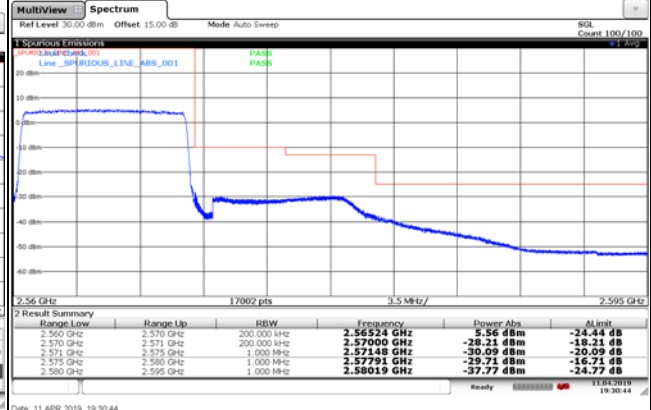
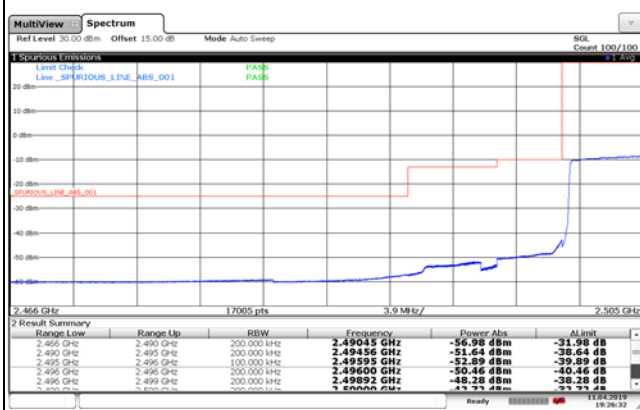

Channel Bandwidth: 15MHz

Channel 20825
(2507.5MHz)

QPSK

1 RB / 0 RB Offset

Channel 21375
(2562.5MHz)

QPSK

1 RB / 74RB Offset

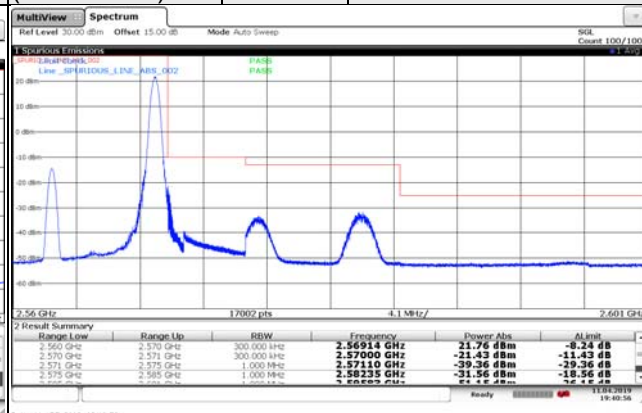
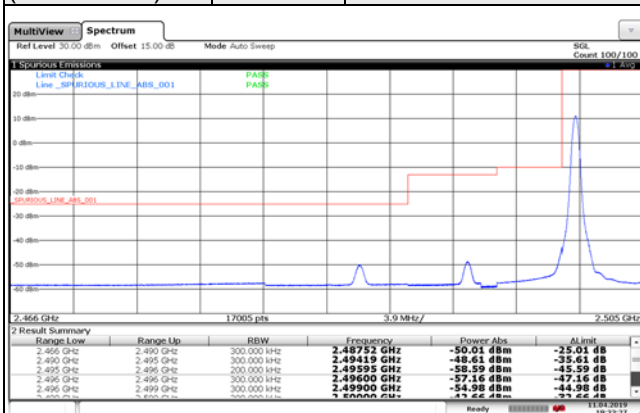

Channel 20825
(2507.5MHz)

QPSK

75 RB / 0 RB Offset

Channel 21375
(2562.5MHz)

QPSK

75 RB / 0 RB Offset

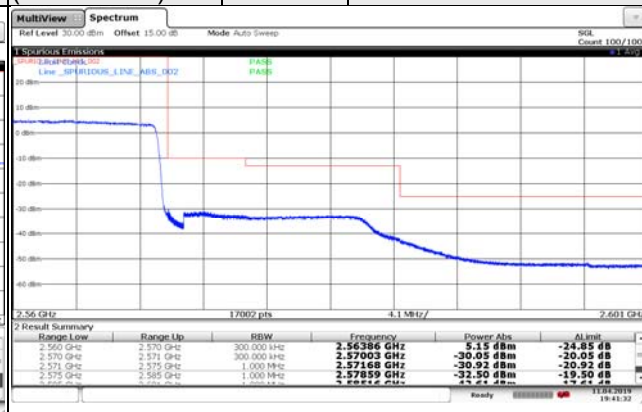
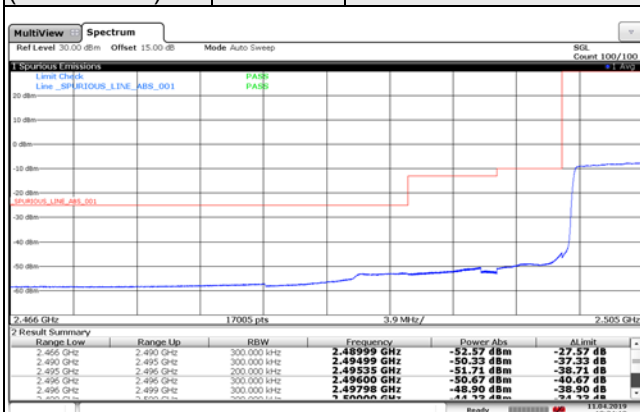

Channel Bandwidth: 20MHz

Channel 20850
(2510MHz)

QPSK

1 RB / 0 RB Offset

Channel 21350
(2560MHz)

QPSK

1 RB / 99RB Offset

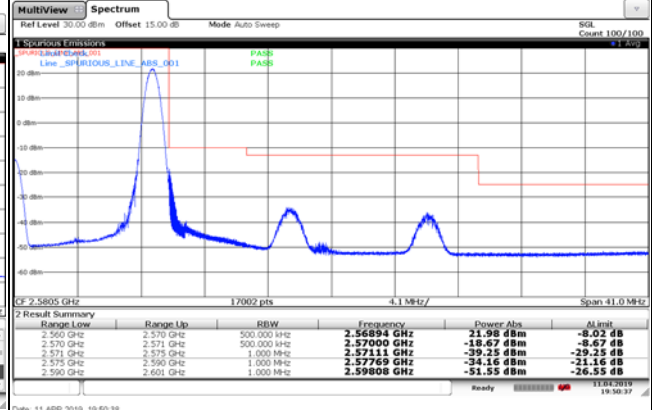
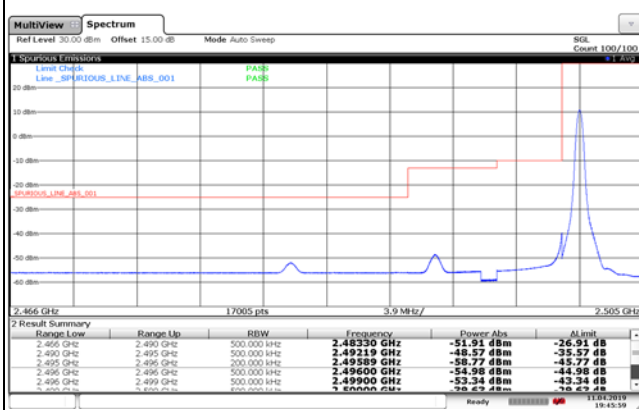

Channel 20850
(2510MHz)

QPSK

100 RB / 0 RB Offset

Channel 21350
(2560MHz)

QPSK

100 RB / 0 RB Offset

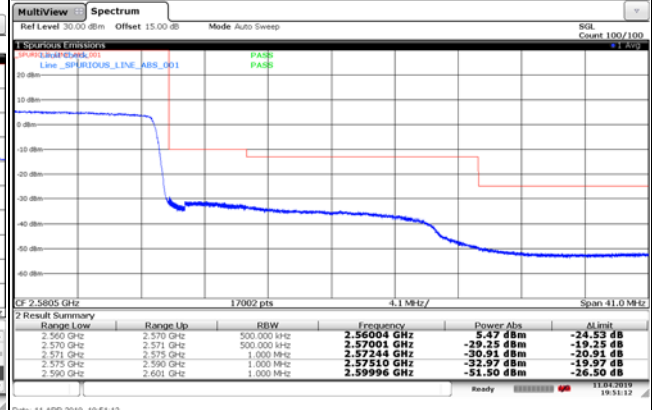
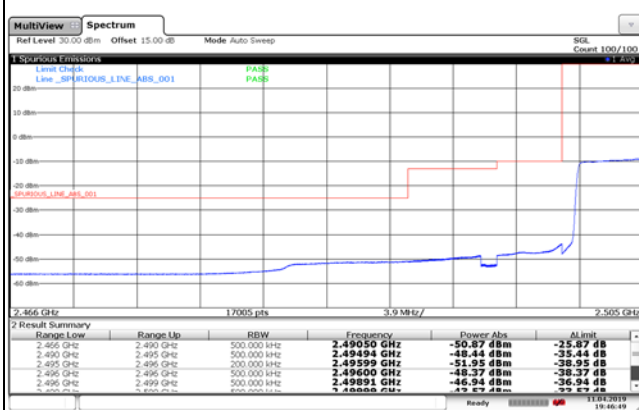

4.6 Peak to Average Ratio

4.6.1 Limits of Peak to Average Ratio Measurement

In measuring transmissions in this band using an average power technique, the peak to-average ratio (PAR) of the transmission may not exceed 13 dB

4.6.2 Test Setup

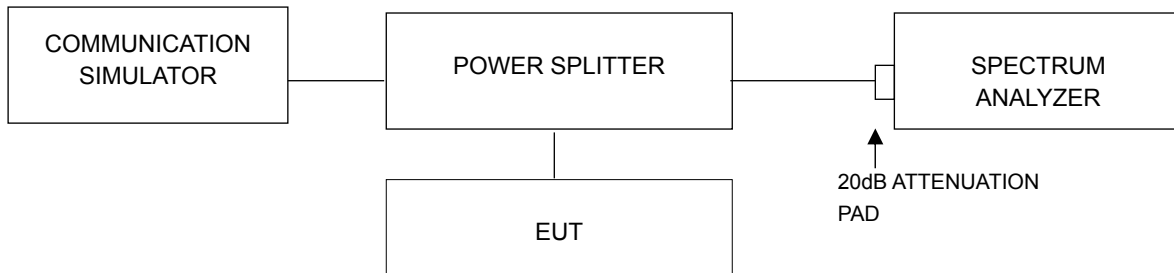

4.6.3 Test Procedures

- Set resolution/measurement bandwidth \geq signal's occupied bandwidth;
- Set the number of counts to a value that stabilizes the measured CCDF curve;
- Record the maximum PAPR level associated with a probability of 0.1%.

4.6.4 Test Results

WCDMA Band 4

Channel	Frequency (MHz)	Peak To Average Ratio (dB)		
		WCDMA	HSDPA	HSUPA
1312	1712.4	3.06	3.05	3.05
1413	1732.6	3.06	3.06	3.06
1513	1752.6	2.99	2.98	2.98

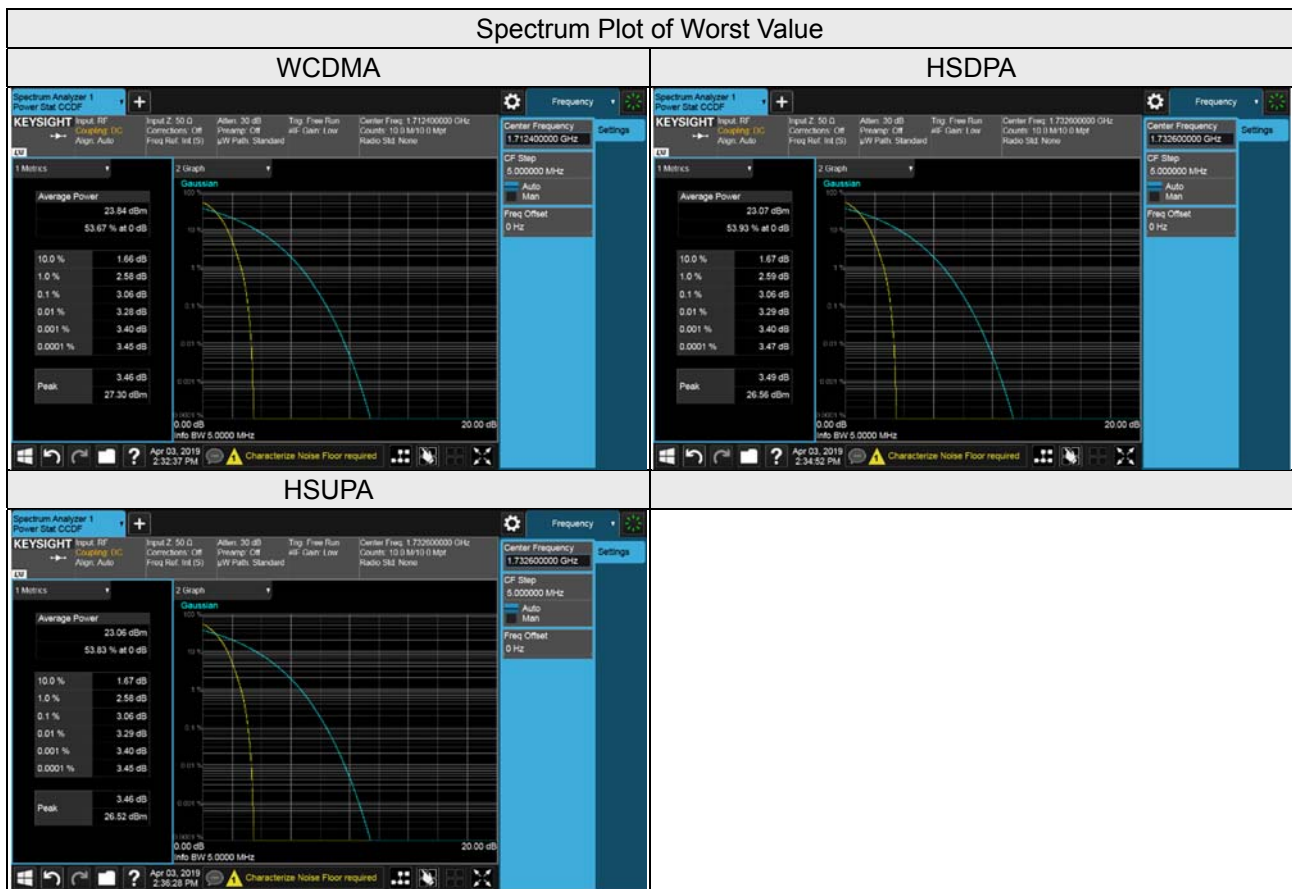

LTE Band 4

LTE Band 4, Channel Bandwidth 1.4MHz				
Channel	Frequency (MHz)	Peak To Average Ratio (dB)		
		QPSK	16QAM	64QAM
19957	1710.7	4.71	5.62	5.70
20175	1732.5	4.74	5.62	5.65
20393	1754.3	4.50	5.25	5.56
LTE Band 4, Channel Bandwidth 3MHz				
Channel	Frequency (MHz)	Peak To Average Ratio (dB)		
		QPSK	16QAM	64QAM
19965	1711.5	4.78	5.54	5.77
20175	1732.5	4.71	5.65	5.82
20385	1753.5	4.64	5.58	5.61
LTE Band 4, Channel Bandwidth 5MHz				
Channel	Frequency (MHz)	Peak To Average Ratio (dB)		
		QPSK	16QAM	64QAM
19975	1712.5	4.70	5.57	5.73
20175	1732.5	4.71	5.62	5.71
20375	1752.5	4.64	5.50	5.60
LTE Band 4, Channel Bandwidth 10MHz				
Channel	Frequency (MHz)	Peak To Average Ratio (dB)		
		QPSK	16QAM	64QAM
20000	1715.0	4.63	5.56	5.83
20175	1732.5	4.61	5.54	5.80
20350	1750.0	4.62	5.57	5.69
LTE Band 4, Channel Bandwidth 15MHz				
Channel	Frequency (MHz)	Peak To Average Ratio (dB)		
		QPSK	16QAM	64QAM
20025	1717.5	4.60	5.60	5.84
20175	1732.5	4.73	5.61	5.77
20325	1747.5	4.57	5.49	5.56

LTE Band 4, Channel Bandwidth 20MHz

Channel	Frequency (MHz)	Peak To Average Ratio (dB)		
		QPSK	16QAM	64QAM
20050	1720.0	4.62	5.52	5.76
20175	1732.5	4.58	5.48	5.74
20300	1745.0	4.54	5.46	5.42

Spectrum Plot of Worst Value

1.4MHz / 64QAM

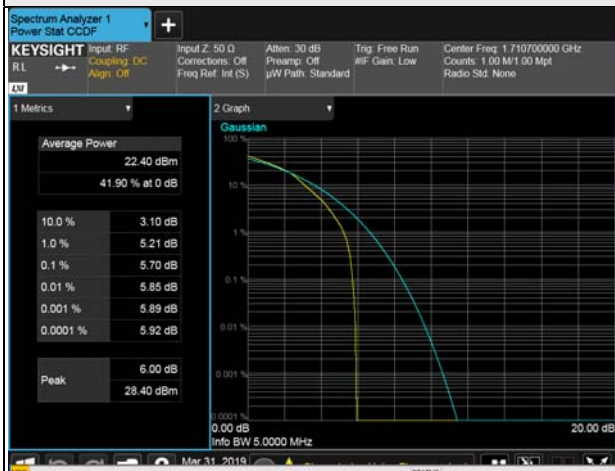

3MHz / 64QAM

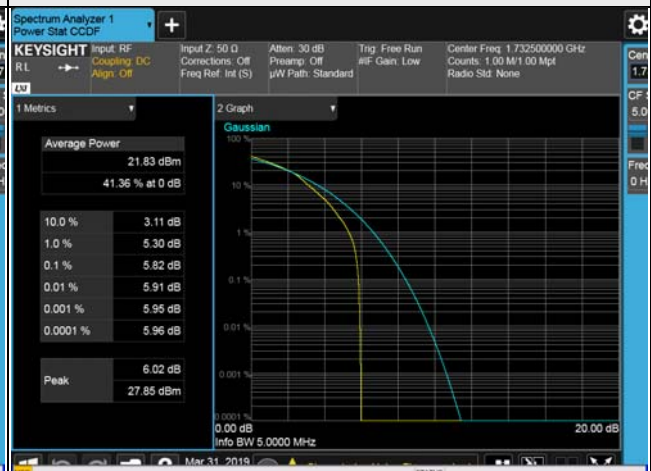

5MHz / 64QAM



10MHz / 64QAM



15MHz / 64QAM



20MHz / 64QAM



LTE Band 7

LTE Band 7, Channel Bandwidth 5MHz				
Channel	Frequency (MHz)	Peak To Average Ratio (dB)		
		QPSK	16QAM	64QAM
20775	2502.5	4.29	5.28	5.33
21100	2535.0	4.42	5.43	5.61
21425	2567.5	4.31	5.30	5.39
LTE Band 7, Channel Bandwidth 10MHz				
Channel	Frequency (MHz)	Peak To Average Ratio (dB)		
		QPSK	16QAM	64QAM
20800	2505.0	4.40	5.25	5.37
21100	2535.0	4.38	5.32	5.45
21400	2565.0	4.37	5.27	5.32
LTE Band 7, Channel Bandwidth 15MHz				
Channel	Frequency (MHz)	Peak To Average Ratio (dB)		
		QPSK	16QAM	64QAM
20825	2507.5	4.30	5.26	5.29
21100	2535.0	4.24	5.20	5.25
21375	2562.5	4.42	5.27	5.30
LTE Band 7, Channel Bandwidth 20MHz				
Channel	Frequency (MHz)	Peak To Average Ratio (dB)		
		QPSK	16QAM	64QAM
20850	2510.0	4.53	5.27	5.32
21100	2535.0	4.26	5.23	5.34
21350	2560.0	4.50	5.39	5.43

Spectrum Plot of Worst Value

5MHz / 64QAM

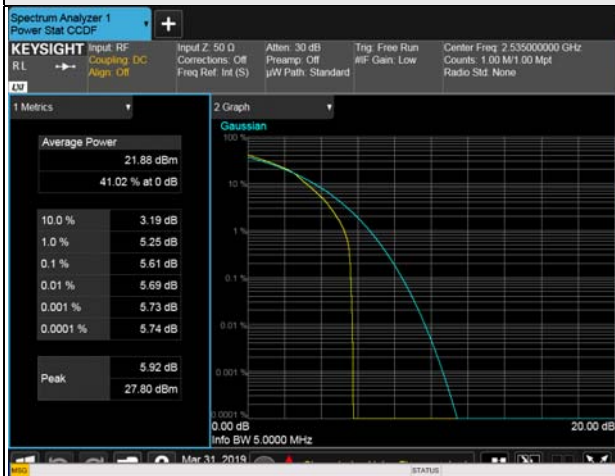

10MHz / 64QAM



15MHz / 64QAM

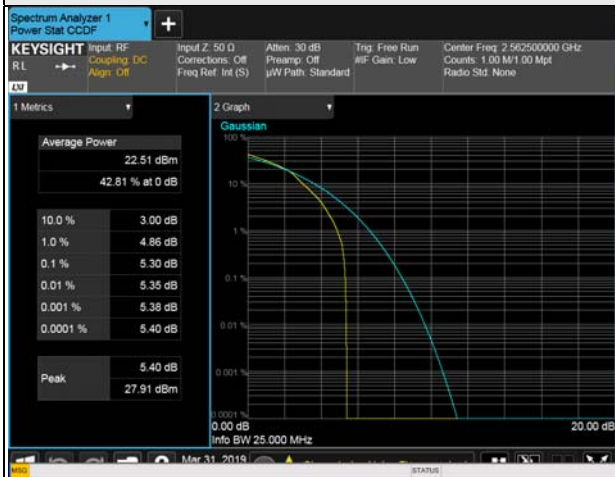

20MHz / 64QAM



4.7 Conducted Spurious Emissions

4.7.1 Limits of Conducted Spurious Emissions Measurement

For WCDMA Band 4, LTE Band 4

In the FCC 27.53(m)(4), On any frequency outside a licensee's frequency block, The power of any emission shall be attenuated below the transmitter power (P) by at least $43 + 10 \log (P)$ dB. The emission limit equal to -13dBm .

For LTE Band 7

In the FCC 27.53(m)(4), On any frequency outside a licensee's frequency block, The power of any emission shall be attenuated below the transmitter power (P) by at least $55 + 10 \log (P)$ dB. The emission limit equal to -25dBm .

4.7.2 Test Setup

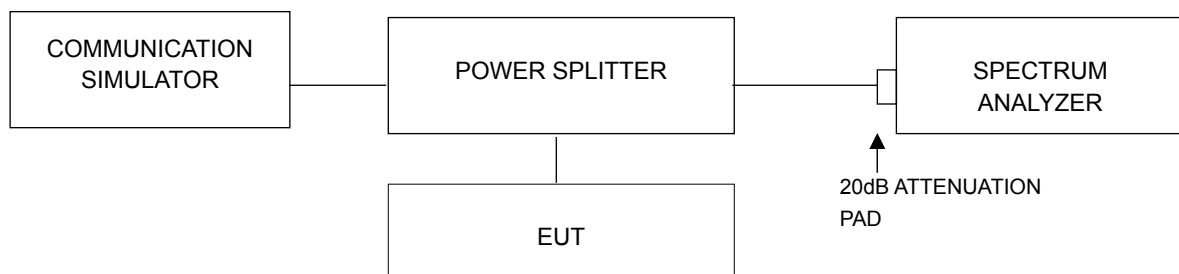

4.7.3 Test Procedure

- All measurements were done at 3 channels: low, middle and high operational frequency range.
- When the spectrum scanned from 9kHz to 26.5GHz or 27GHz, it shall be connected to the attenuator with the carried frequency.

4.7.4 Test Results

WCDMA Band 4

WCDMA

Channel 1312 (1712.4MHz)

Frequency Range : 9kHz~1GHz

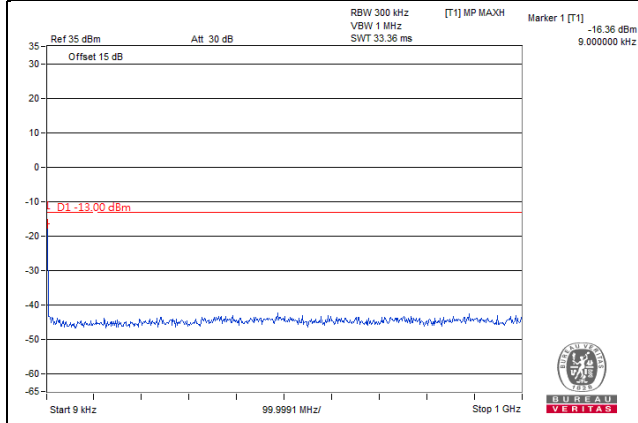

Frequency Range : 1GHz~10GHz

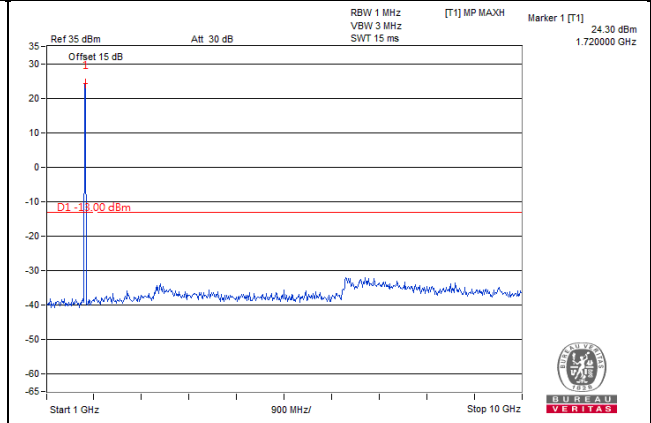

Frequency Range : 10GHz~26.5GHz

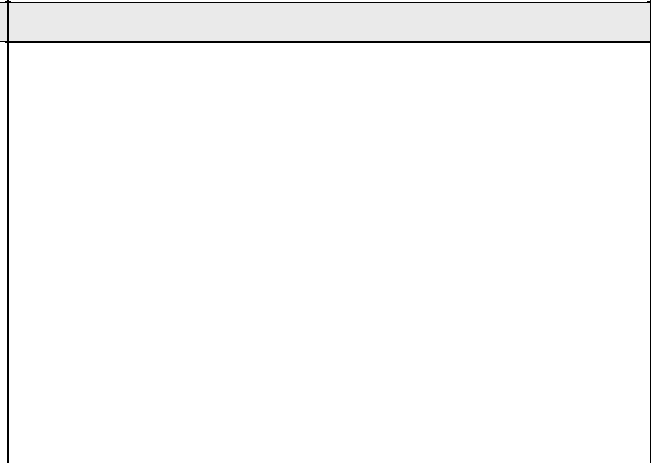
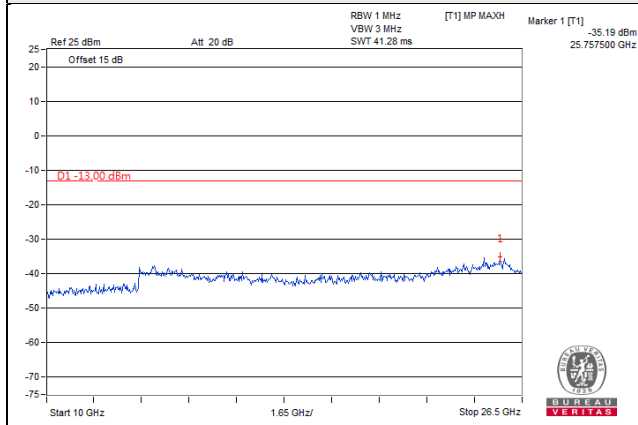

WCDMA

Channel 1413 (1732.6MHz)

Frequency Range : 9kHz~1GHz

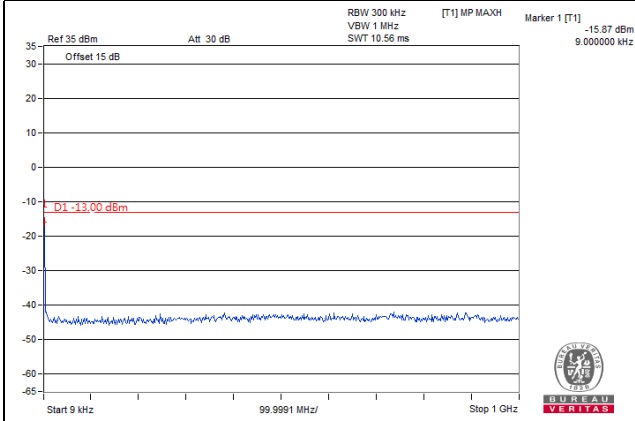

Frequency Range : 1GHz~10GHz

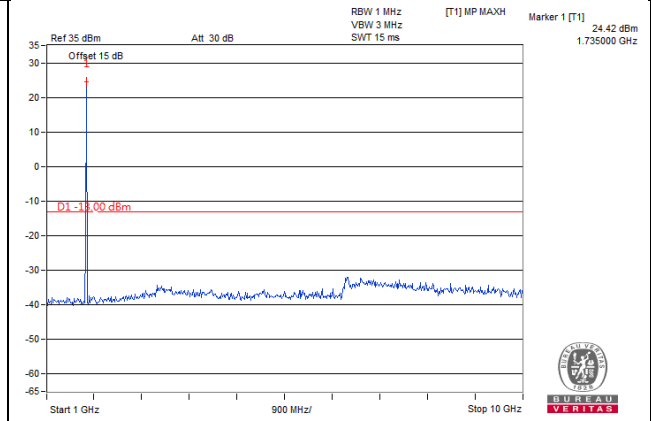

Frequency Range : 10GHz~26.5GHz

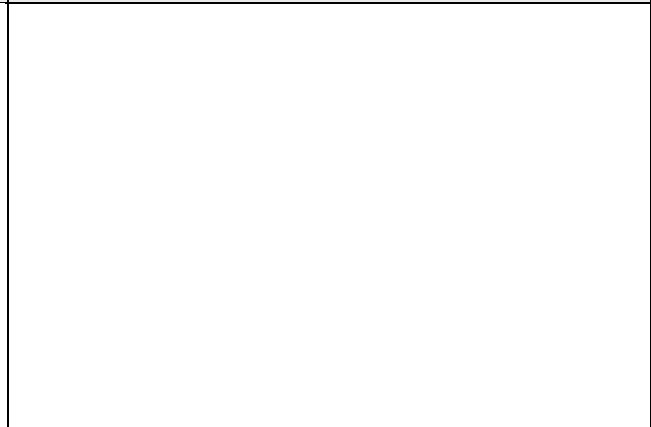
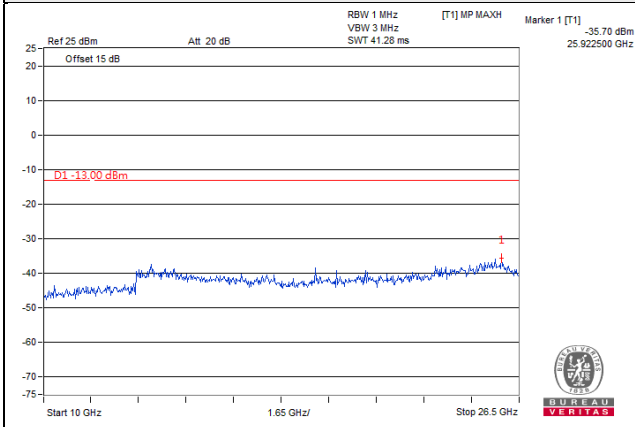

WCDMA

Channel 1513 (1752.6MHz)

Frequency Range : 9kHz~1GHz

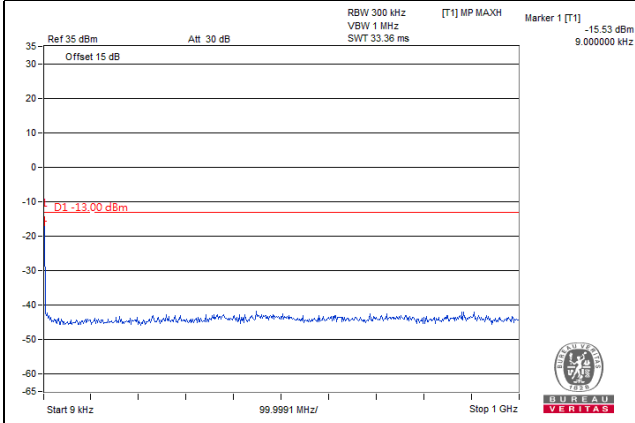

Frequency Range : 1GHz~10GHz

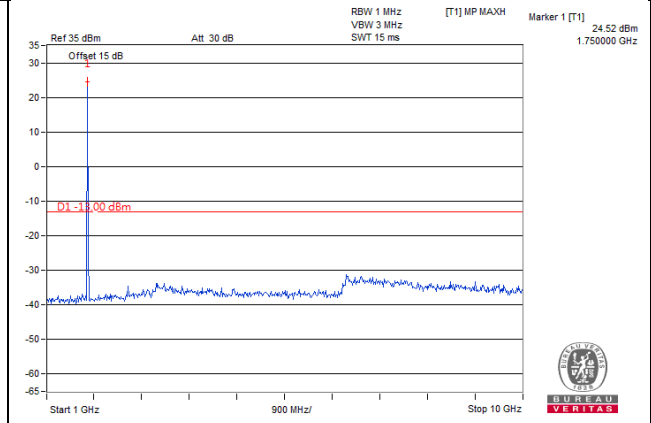

Frequency Range : 10GHz~26.5GHz

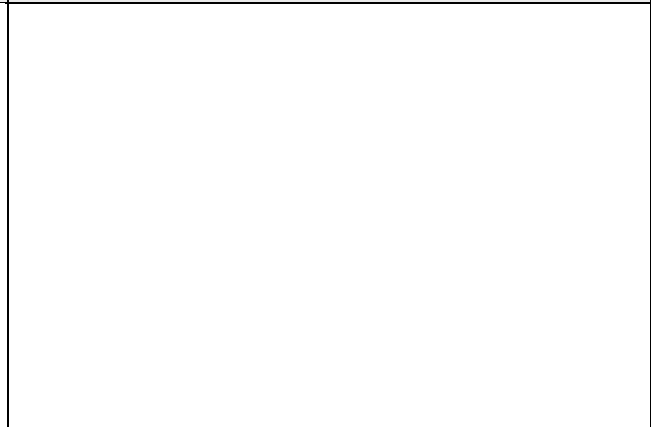
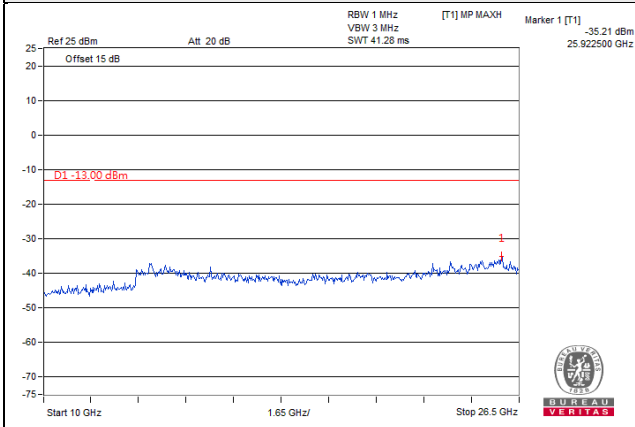

HSDPA

Channel 1312 (1712.4MHz)

Frequency Range : 9kHz~1GHz

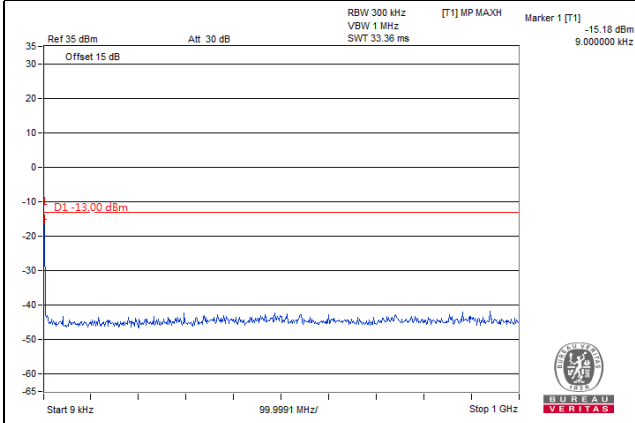

Frequency Range : 1GHz~10GHz

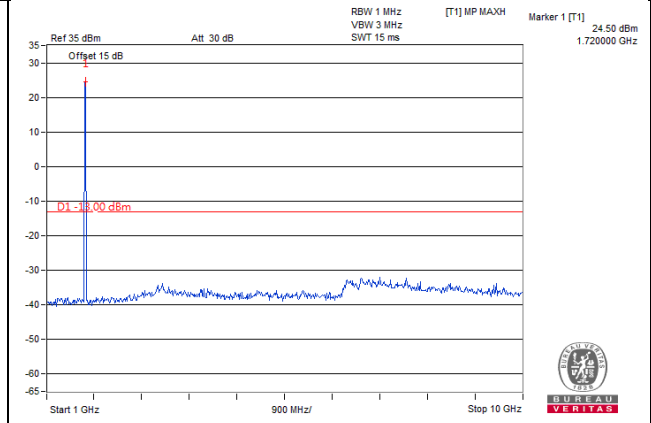

Frequency Range : 10GHz~26.5GHz

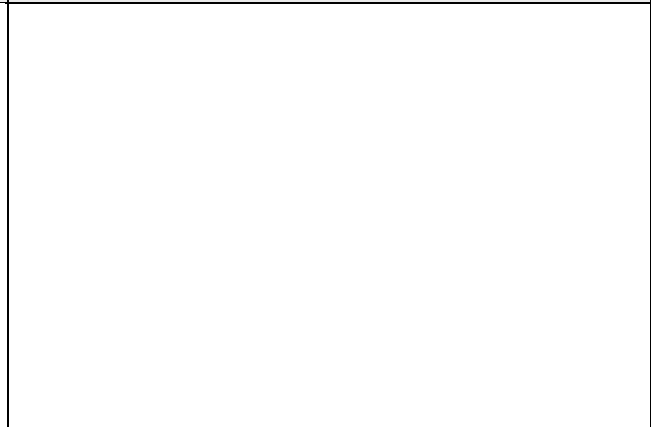
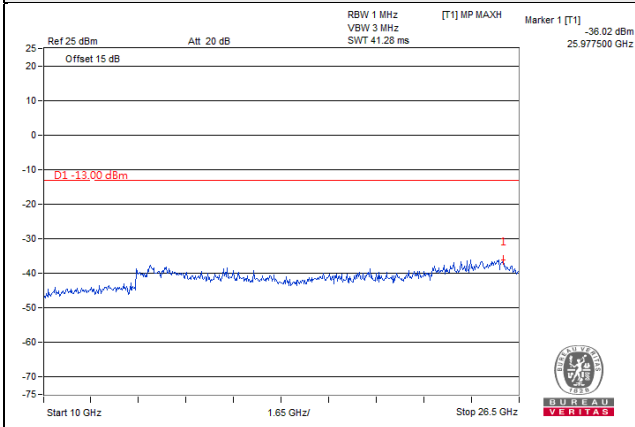

HSDPA

Channel 1413 (1732.6MHz)

Frequency Range : 9kHz~1GHz

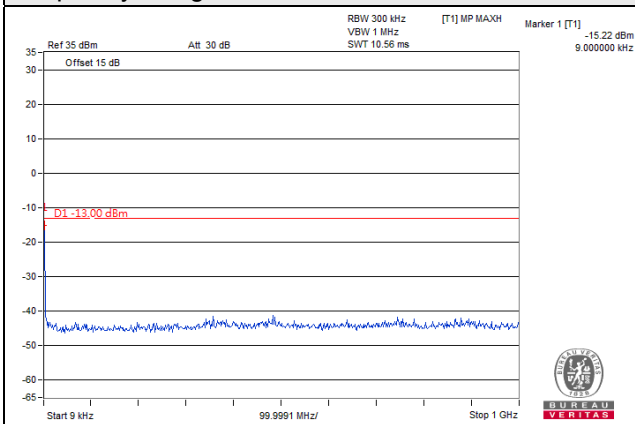

Frequency Range : 1GHz~10GHz

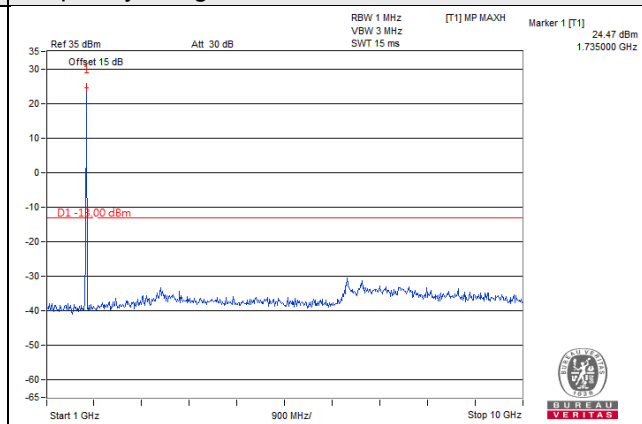

Frequency Range : 10GHz~26.5GHz

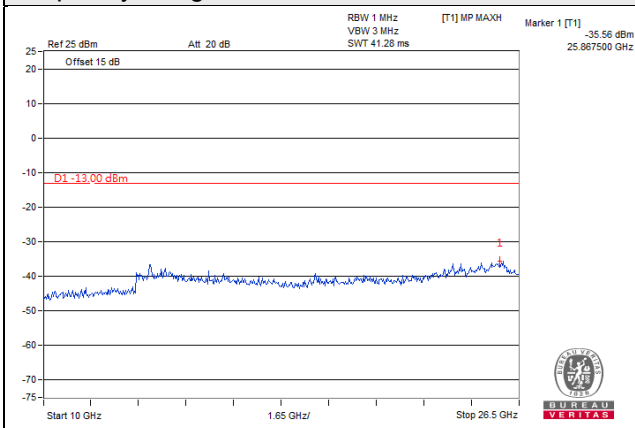

HSDPA

Channel 1513 (1752.6MHz)

Frequency Range : 9kHz~1GHz

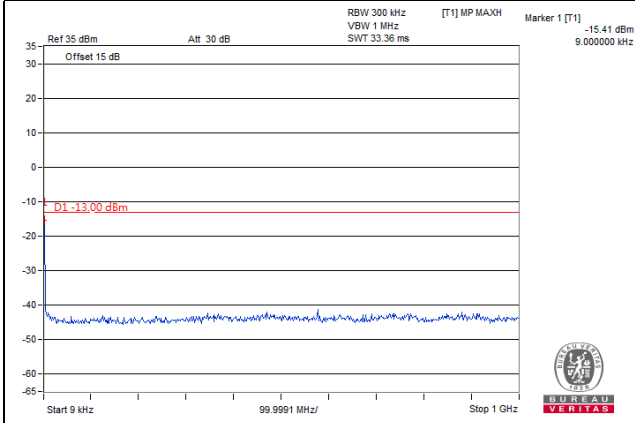

Frequency Range : 1GHz~10GHz

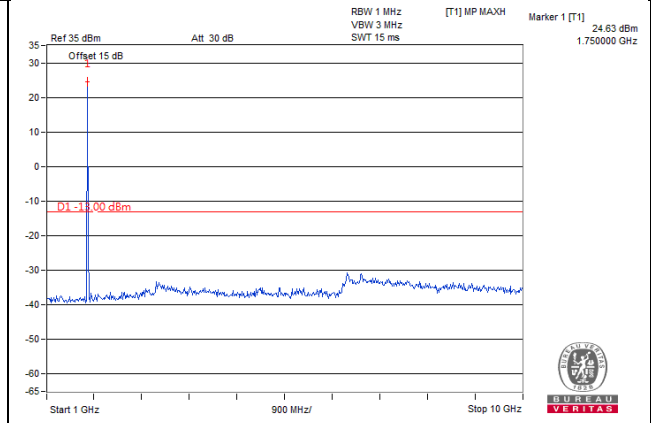

Frequency Range : 10GHz~26.5GHz

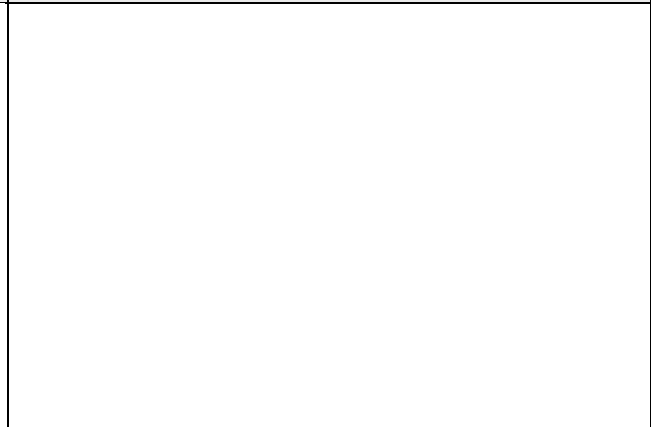
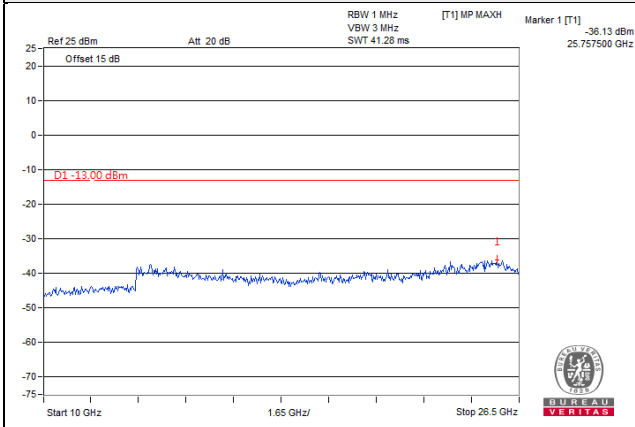

HSUPA

Channel 1312 (1712.4MHz)

Frequency Range : 9kHz~1GHz

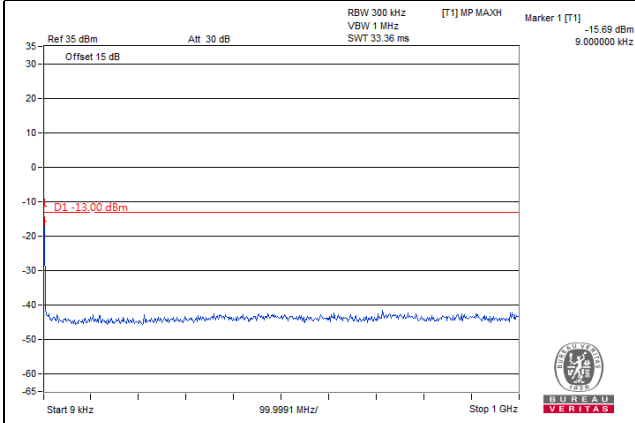

Frequency Range : 1GHz~10GHz

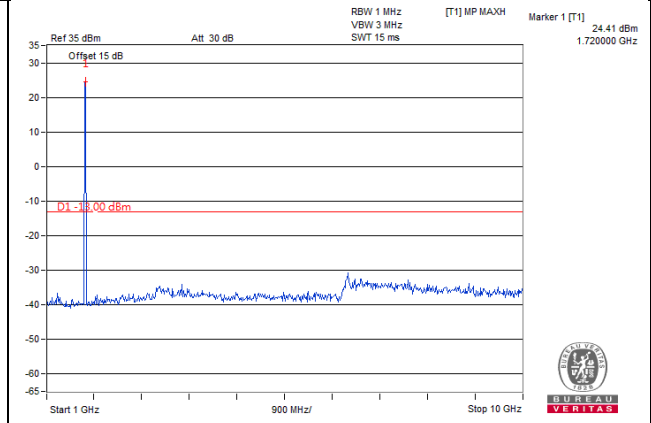

Frequency Range : 10GHz~26.5GHz

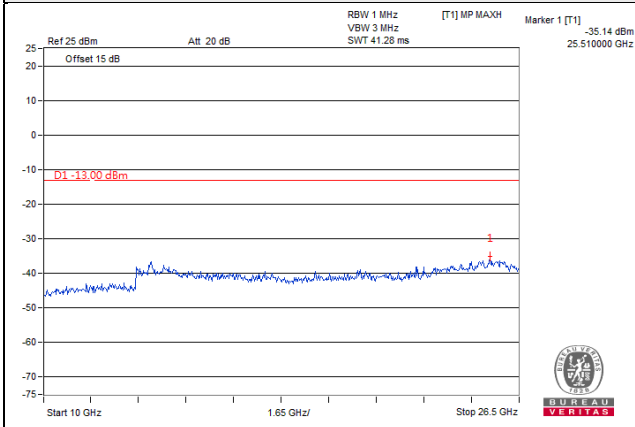

HSUPA

Channel 1413 (1732.6MHz)

Frequency Range : 9kHz~1GHz

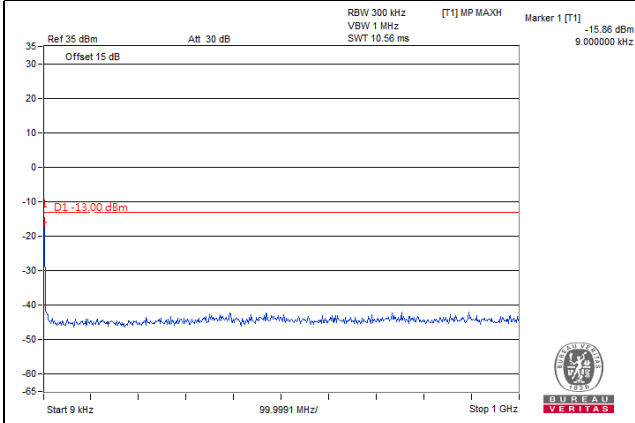

Frequency Range : 1GHz~10GHz

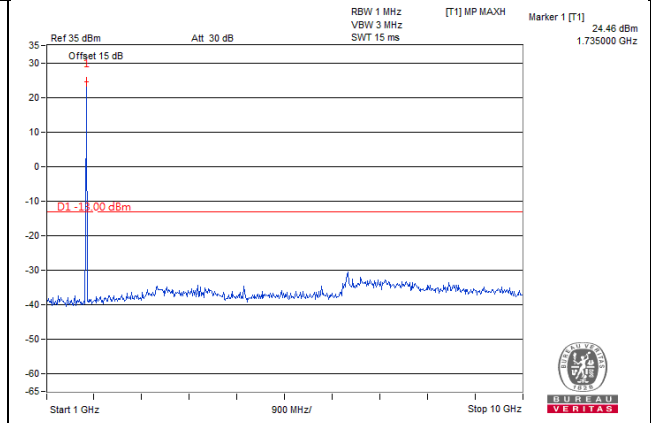

Frequency Range : 10GHz~26.5GHz

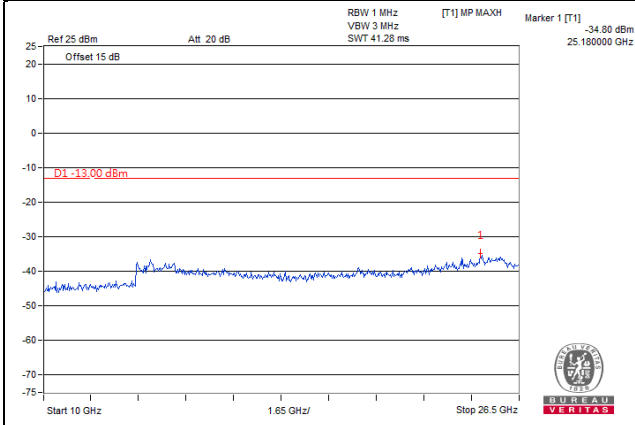

HSUPA

Channel 1513 (1752.6MHz)

Frequency Range : 9kHz~1GHz

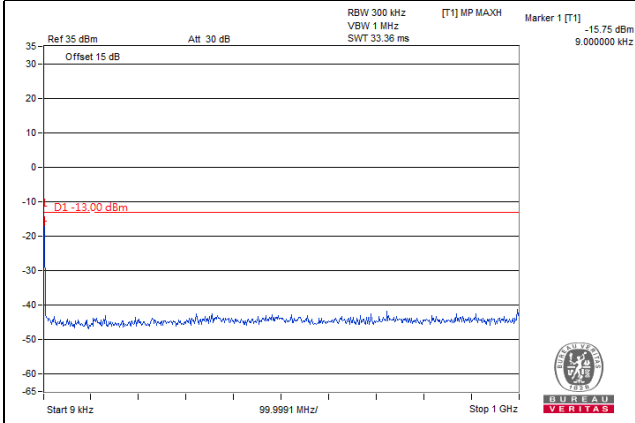

Frequency Range : 1GHz~10GHz

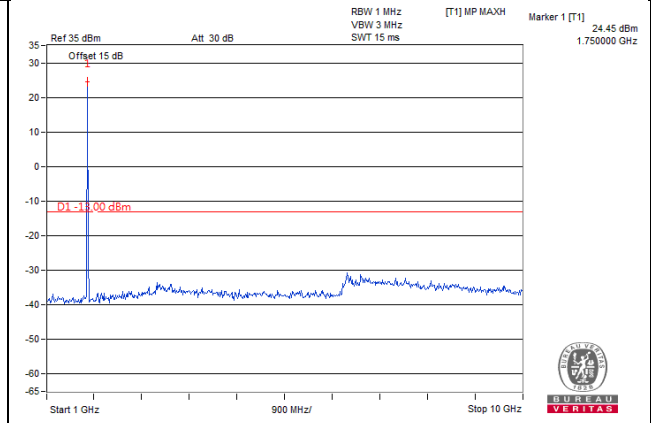

Frequency Range : 10GHz~26.5GHz

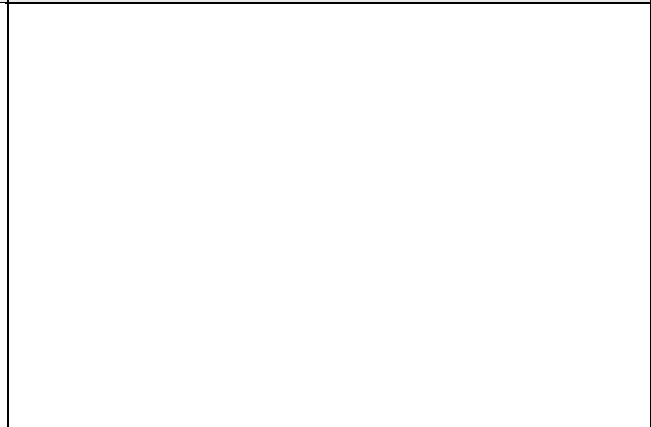
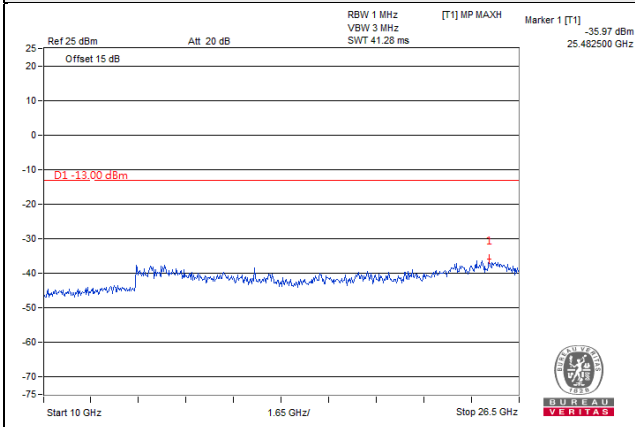

LTE Band 4

Channel Bandwidth: 1.4MHz

Channel 19957 (1710.7MHz)

Frequency Range : 9kHz~1GHz

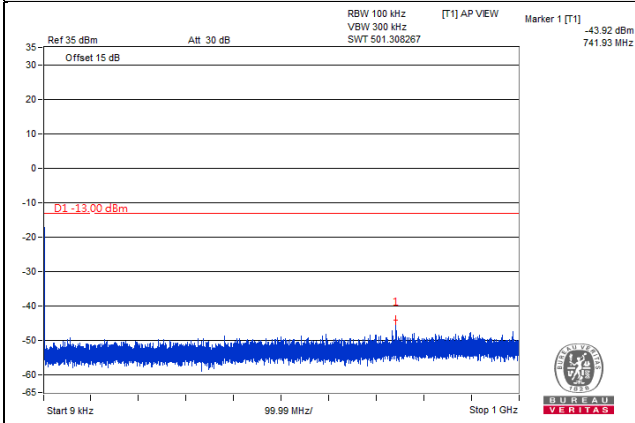

Frequency Range : 1GHz~10GHz

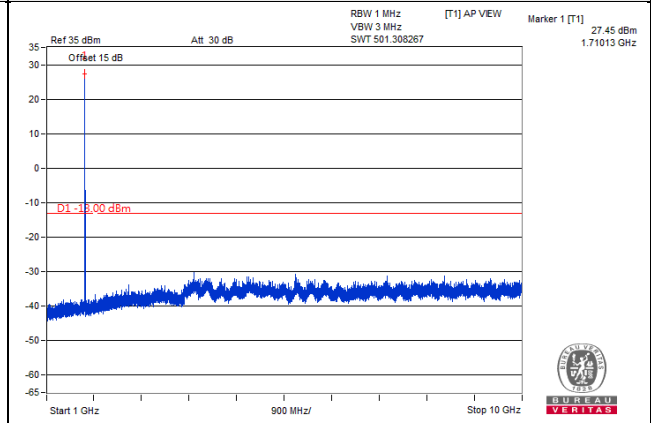

Frequency Range : 10GHz~27GHz

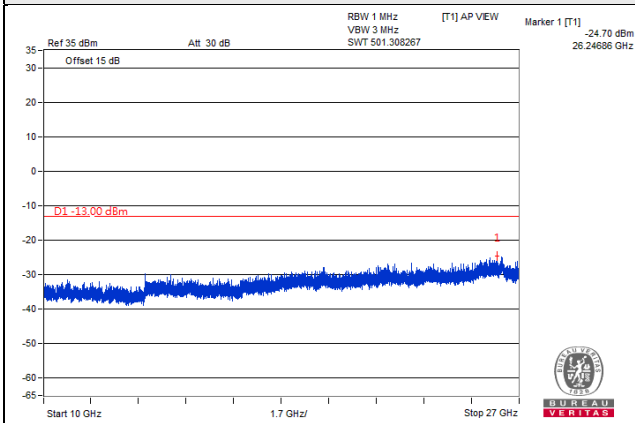

*The 9kHz signal over the limit is from Spectrum.

Channel Bandwidth: 1.4MHz

Channel 20175 (1732.5MHz)

Frequency Range : 9kHz~1GHz

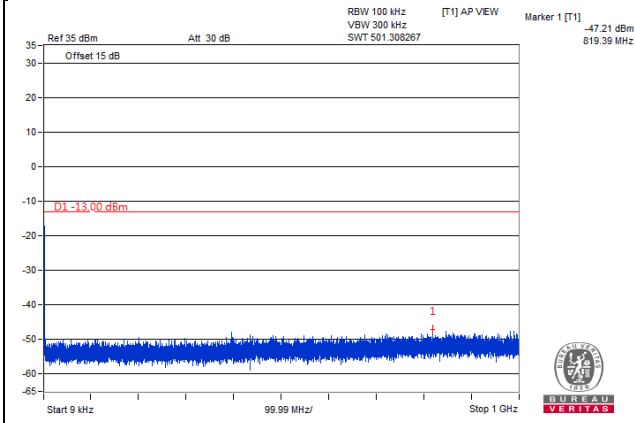

Frequency Range : 1GHz~10GHz

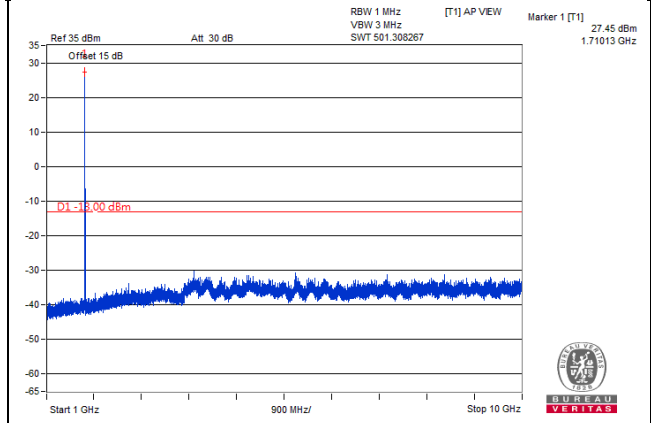

Frequency Range : 10GHz~27GHz

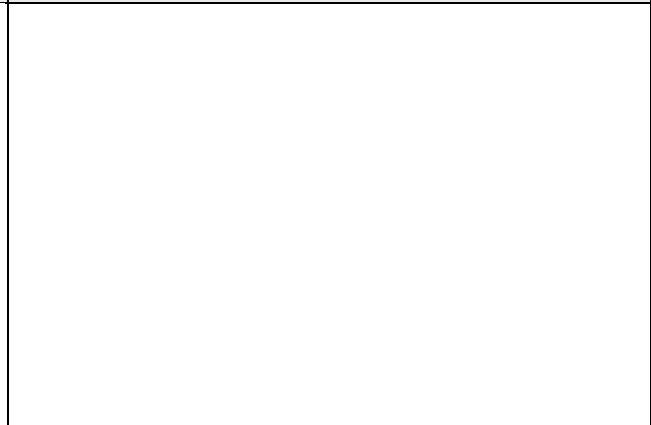
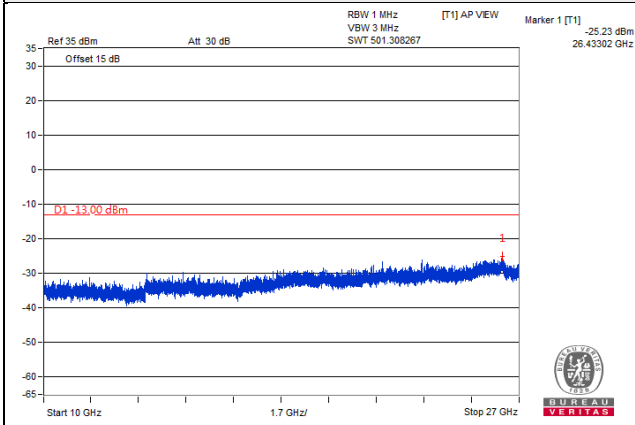

*The 9kHz signal over the limit is from Spectrum.

Channel Bandwidth: 1.4MHz

Channel 20393 (1754.3MHz)

Frequency Range : 9kHz~1GHz

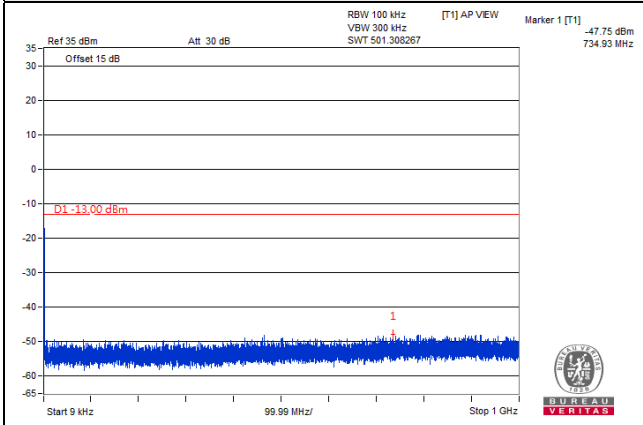

Frequency Range : 1GHz~10GHz

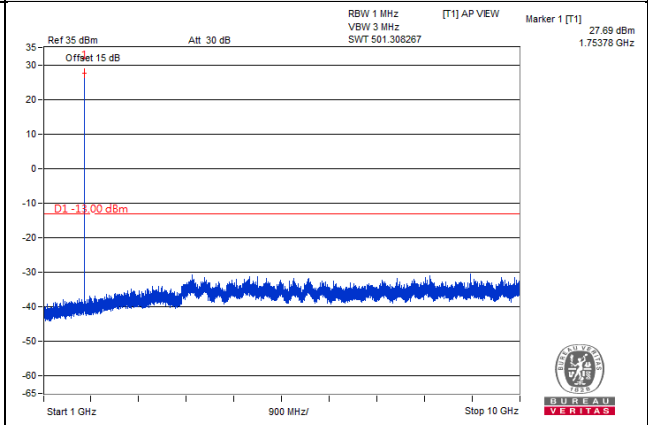

Frequency Range : 10GHz~27GHz

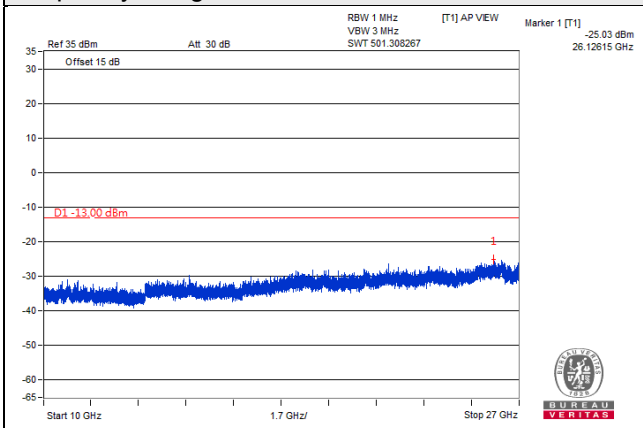

*The 9kHz signal over the limit is from Spectrum.

Channel Bandwidth: 3MHz

Channel 19965 (1711.5MHz)

Frequency Range : 9kHz~1GHz

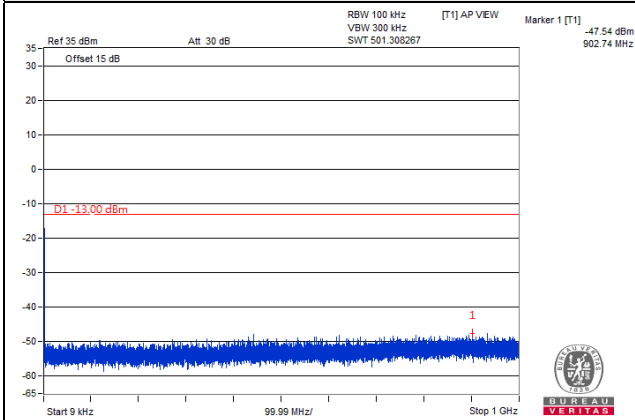

Frequency Range : 1GHz~10GHz

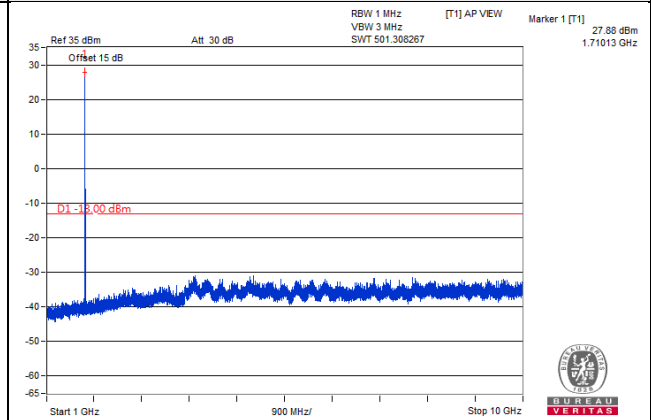

Frequency Range : 10GHz~27GHz

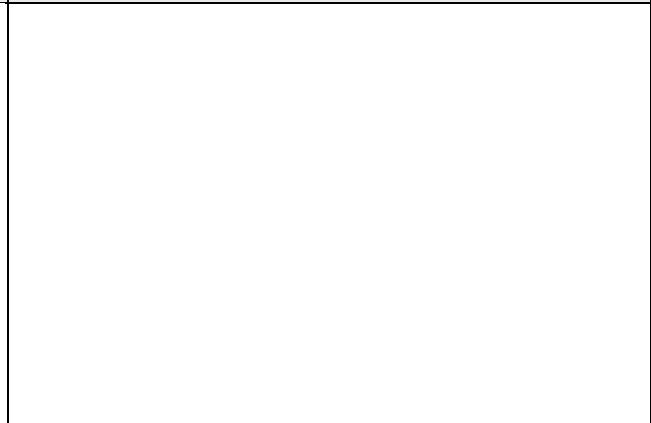
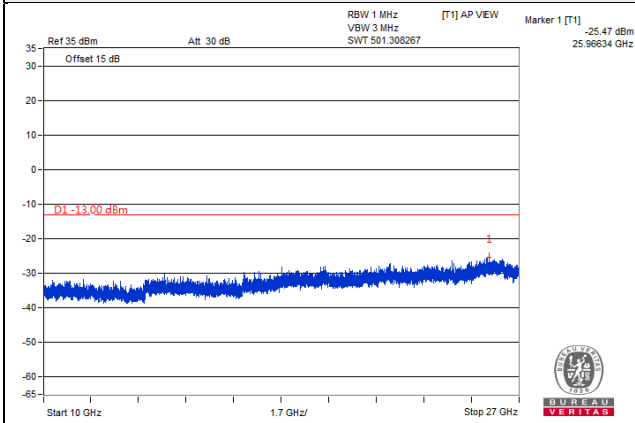

*The 9kHz signal over the limit is from Spectrum.

Channel Bandwidth: 3MHz

Channel 20175 (1732.5MHz)

Frequency Range : 9kHz~1GHz

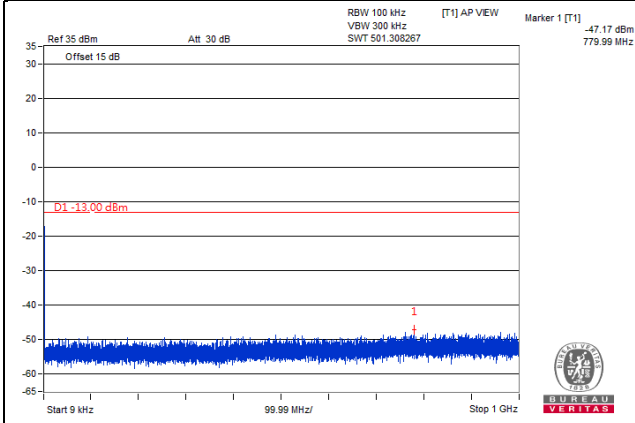

Frequency Range : 1GHz~10GHz

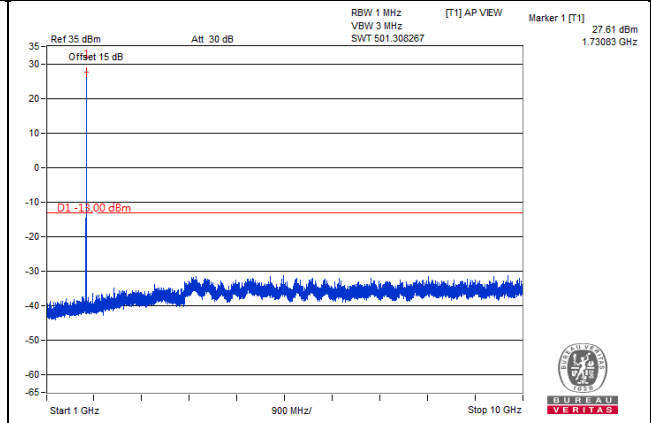

Frequency Range : 10GHz~27GHz

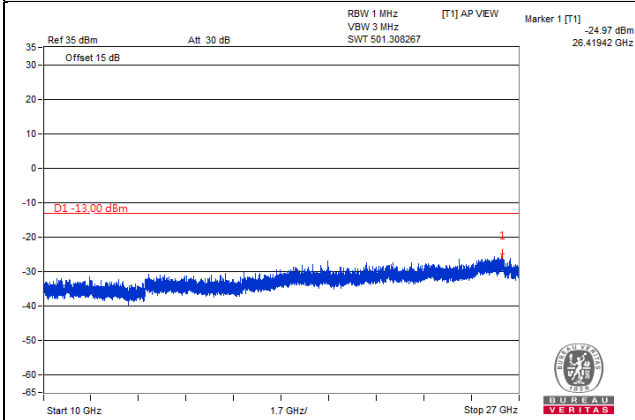

*The 9kHz signal over the limit is from Spectrum.

Channel Bandwidth: 3MHz

Channel 20385 (1753.5MHz)

Frequency Range : 9kHz~1GHz

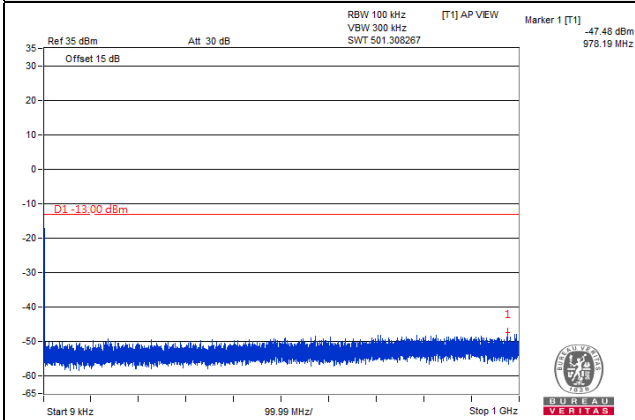

Frequency Range : 1GHz~10GHz

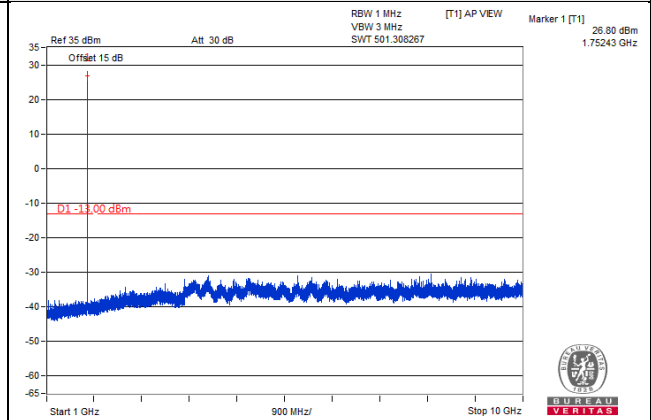

Frequency Range : 10GHz~27GHz

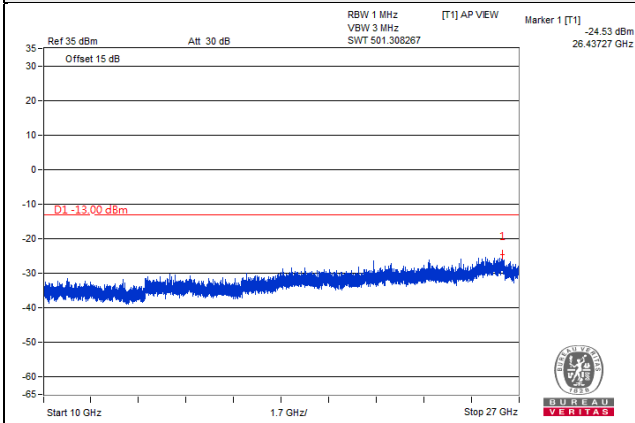

*The 9kHz signal over the limit is from Spectrum.

Channel Bandwidth: 5MHz

Channel 19975 (1712.5MHz)

Frequency Range : 9kHz~1GHz

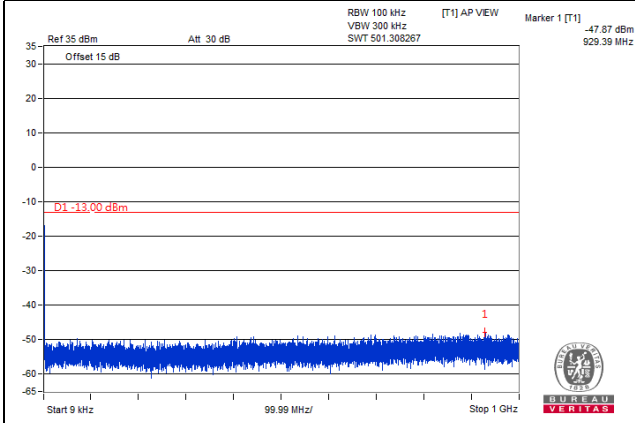

Frequency Range : 1GHz~10GHz

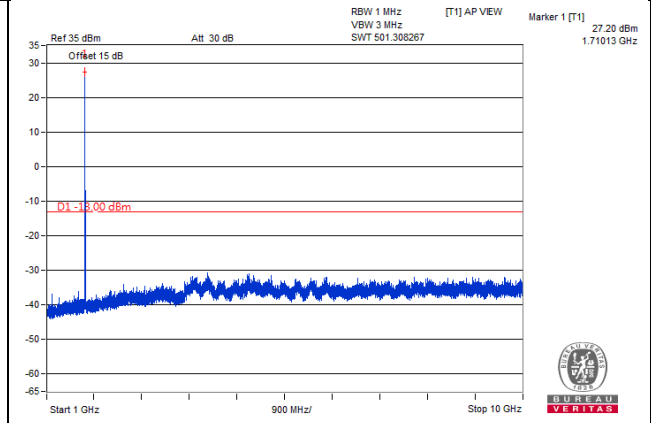

Frequency Range : 10GHz~27GHz

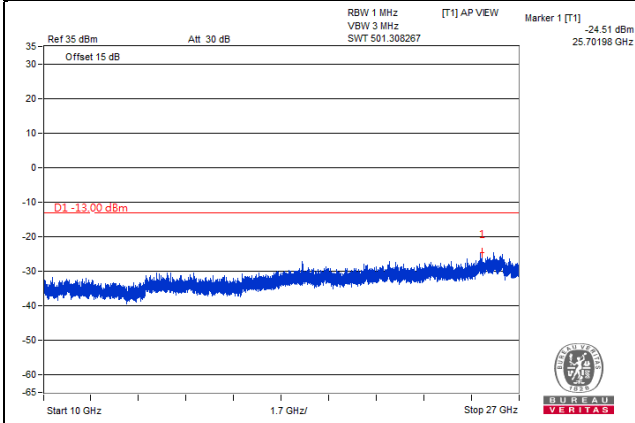

*The 9kHz signal over the limit is from Spectrum.

Channel Bandwidth: 5MHz
 Channel 20175 (1732.5MHz)

Frequency Range : 9kHz~1GHz

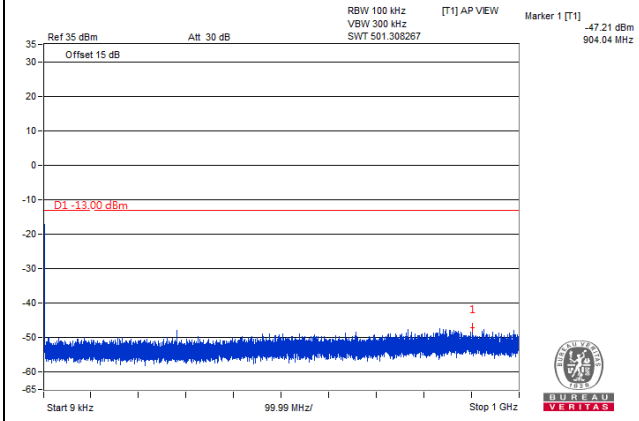

Frequency Range : 1GHz~10GHz

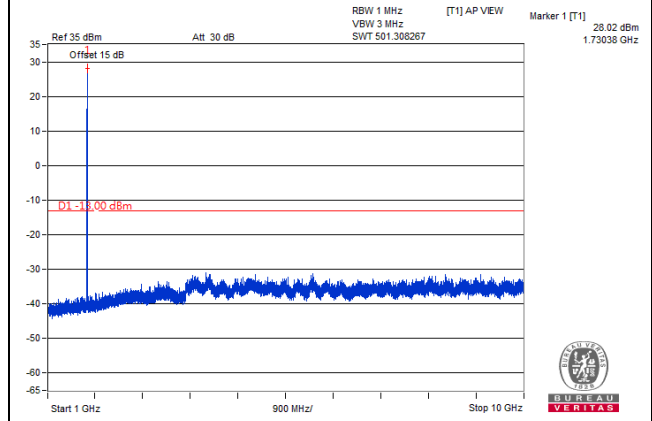

Frequency Range : 10GHz~27GHz

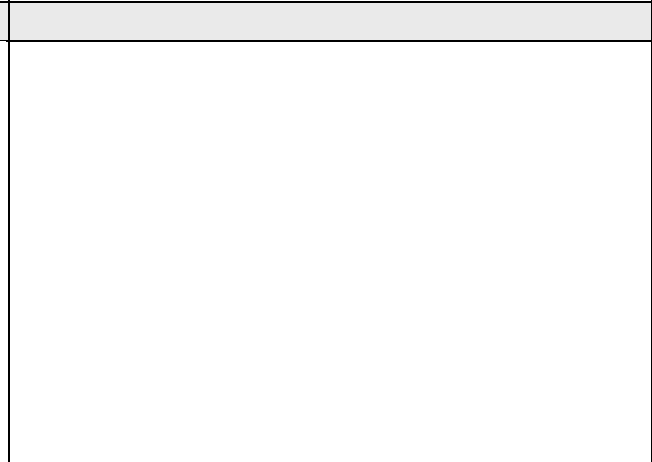
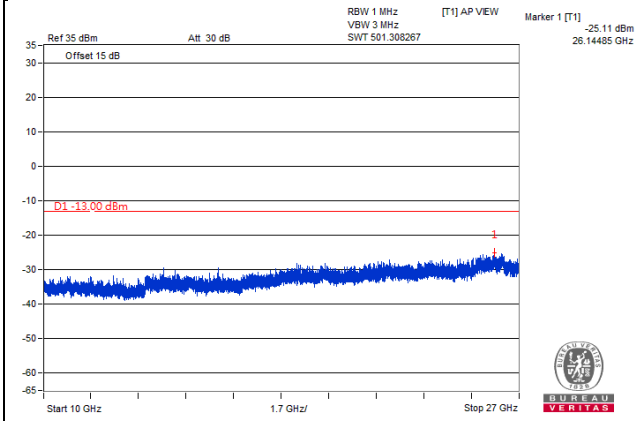

*The 9kHz signal over the limit is from Spectrum.

Channel Bandwidth: 5MHz

Channel 20375 (1752.5MHz)

Frequency Range : 9kHz~1GHz

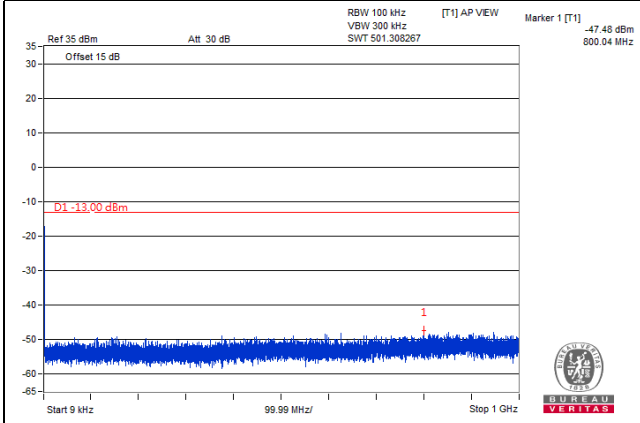

Frequency Range : 1GHz~10GHz

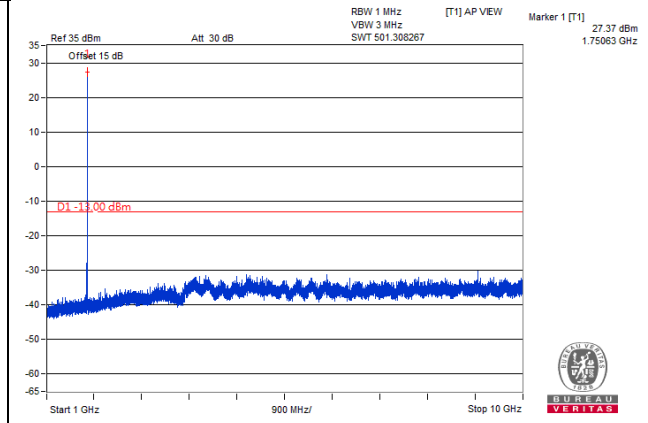

Frequency Range : 10GHz~27GHz

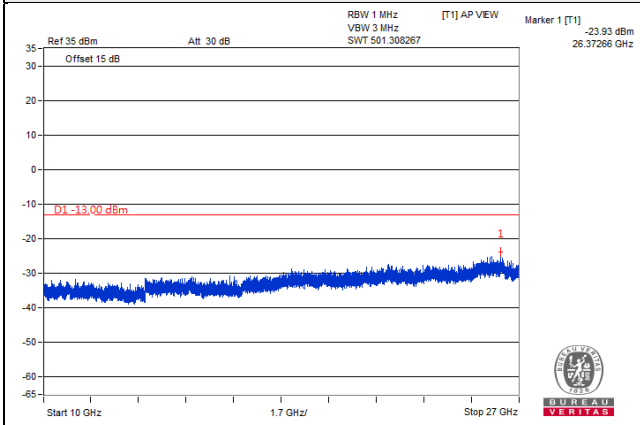

*The 9kHz signal over the limit is from Spectrum.

Channel Bandwidth: 10MHz

Channel 20000 (1715.0MHz)

Frequency Range : 9kHz~1GHz

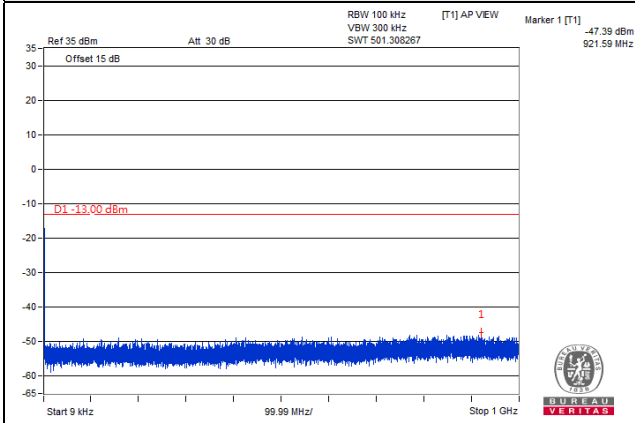

Frequency Range : 1GHz~10GHz

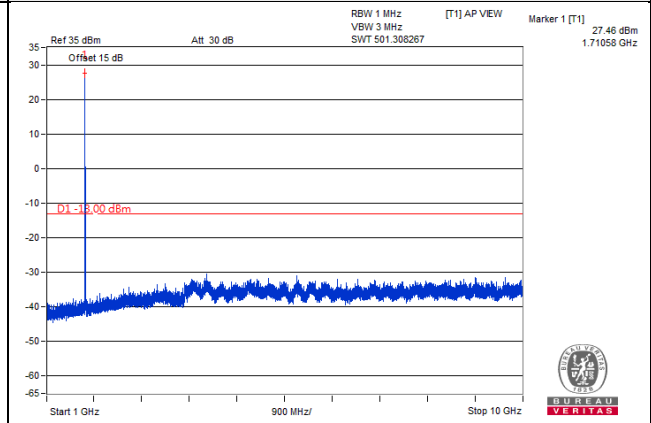

Frequency Range : 10GHz~27GHz

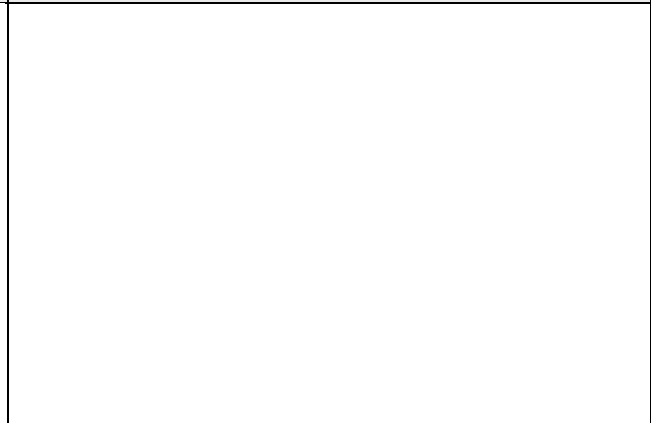
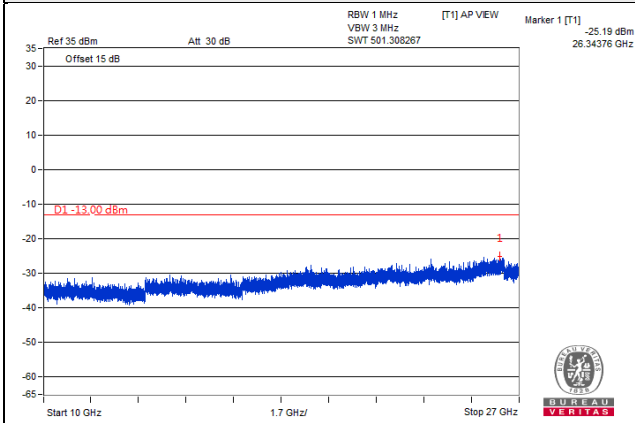

*The 9kHz signal over the limit is from Spectrum.

Channel Bandwidth: 10MHz

Channel 20175 (1732.5MHz)

Frequency Range : 9kHz~1GHz

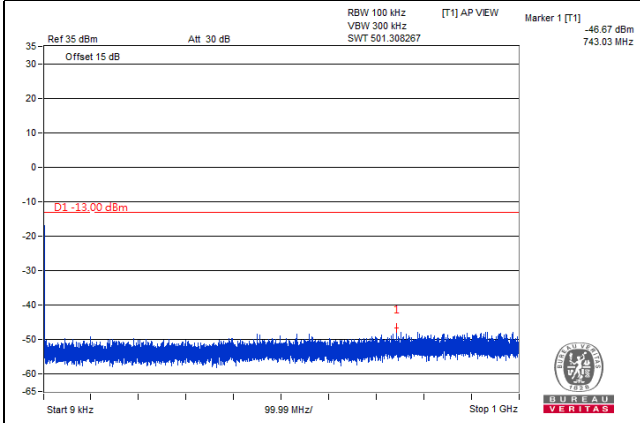

Frequency Range : 1GHz~10GHz

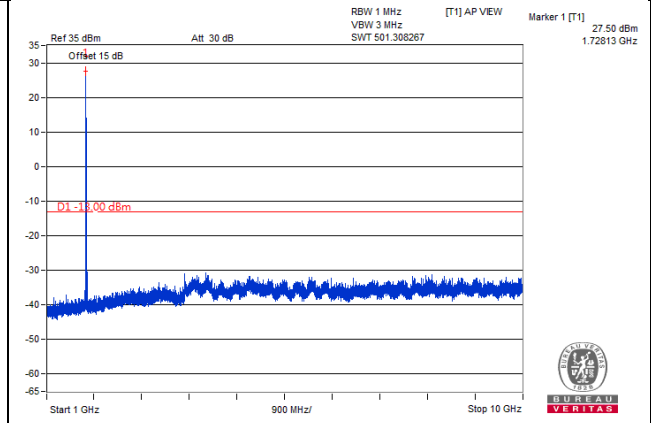

Frequency Range : 10GHz~27GHz

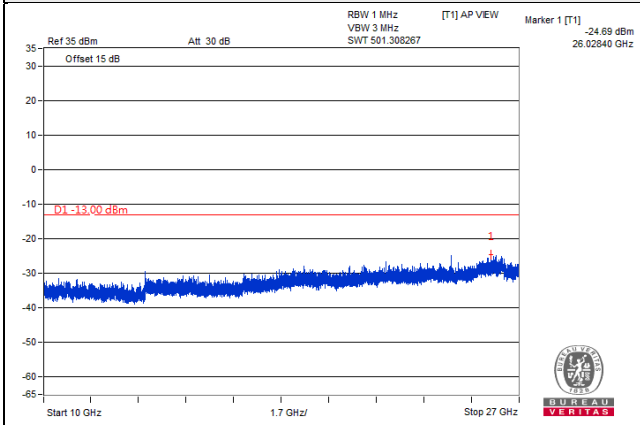

*The 9kHz signal over the limit is from Spectrum.

Channel Bandwidth: 10MHz

Channel 20350 (1750.0MHz)

Frequency Range : 9kHz~1GHz

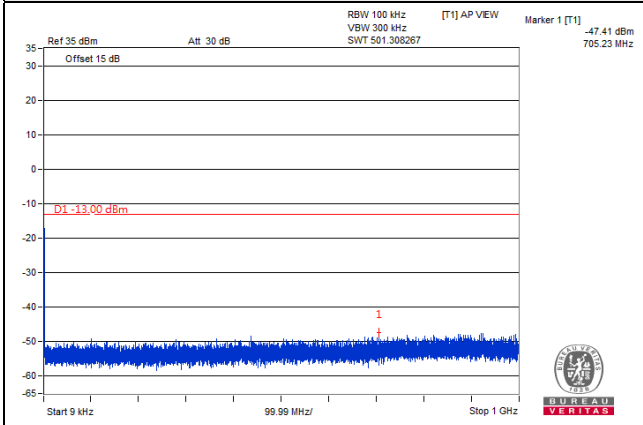

Frequency Range : 1GHz~10GHz

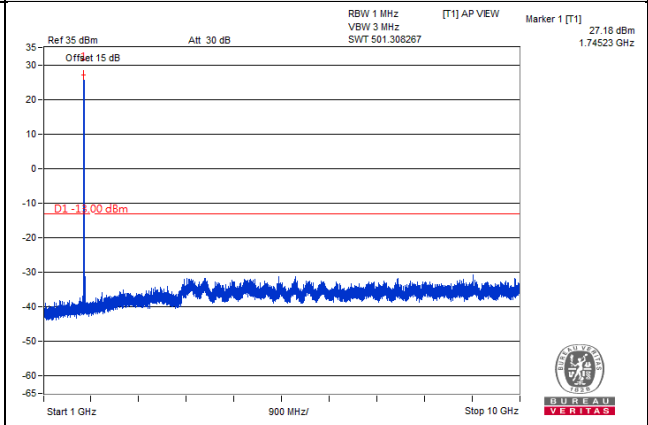

Frequency Range : 10GHz~27GHz

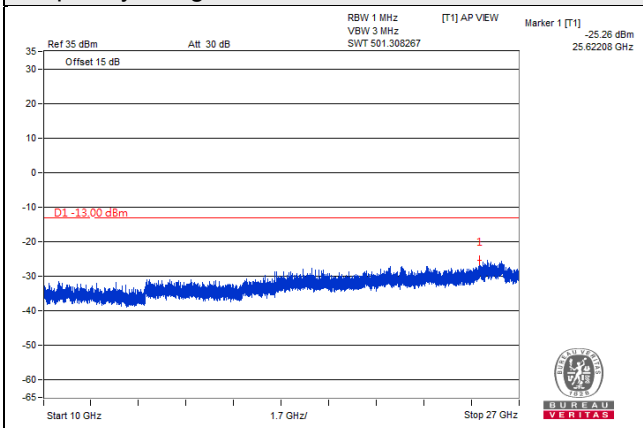

*The 9kHz signal over the limit is from Spectrum.

Channel Bandwidth: 15MHz

Channel 20025 (1717.5MHz)

Frequency Range : 9kHz~1GHz

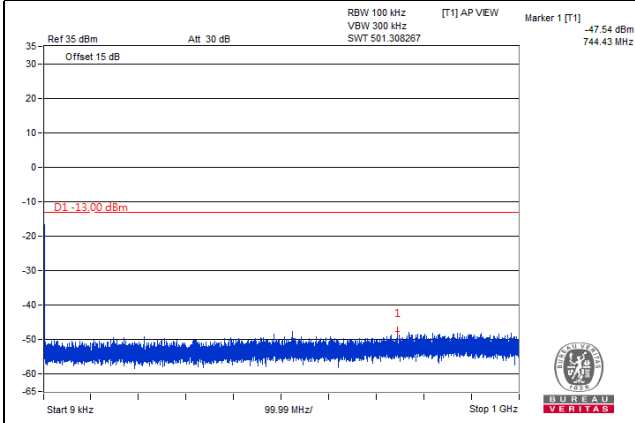

Frequency Range : 1GHz~10GHz

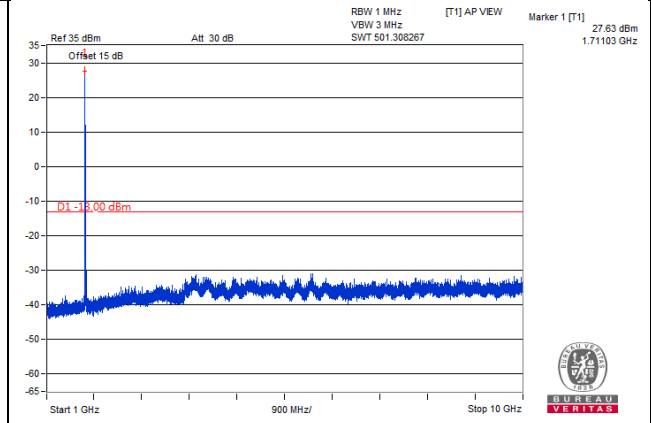

Frequency Range : 10GHz~27GHz

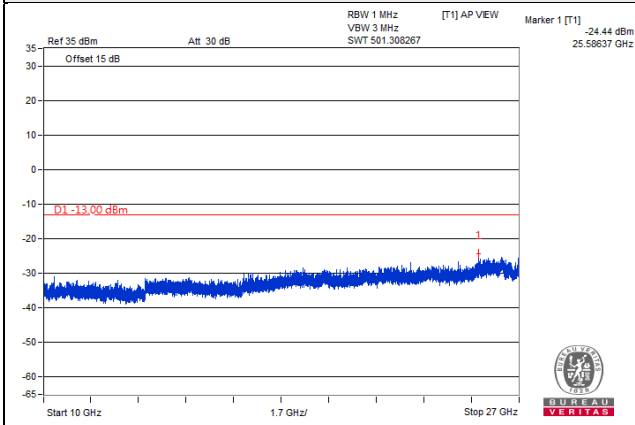

*The 9kHz signal over the limit is from Spectrum.

Channel Bandwidth: 15MHz

Channel 20175 (1732.5MHz)

Frequency Range : 9kHz~1GHz

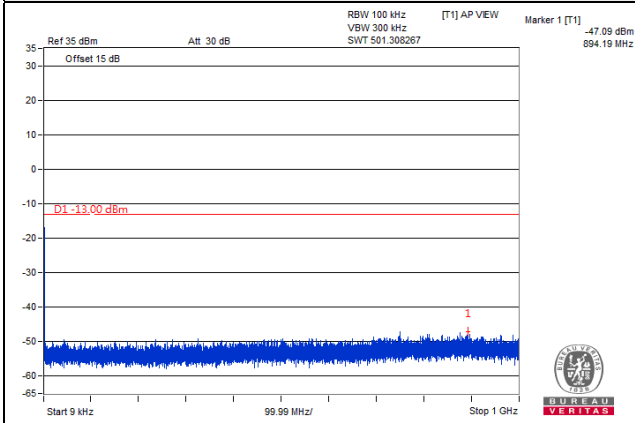

Frequency Range : 1GHz~10GHz

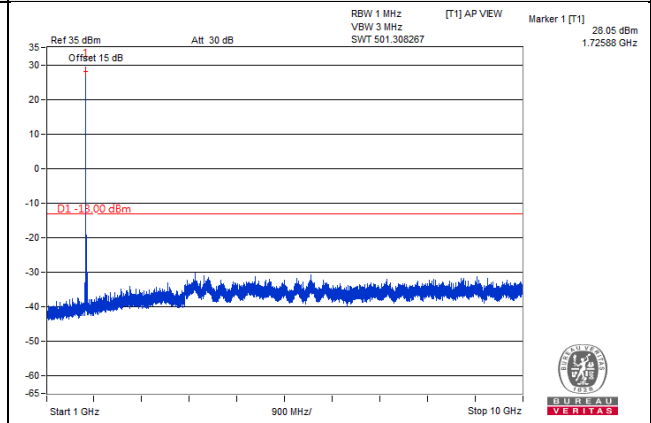

Frequency Range : 10GHz~27GHz

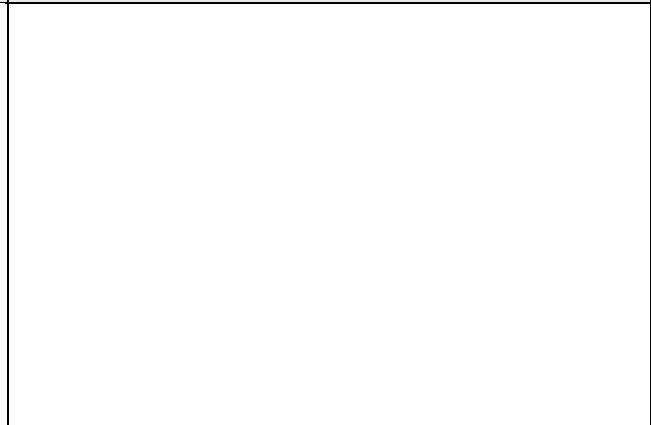
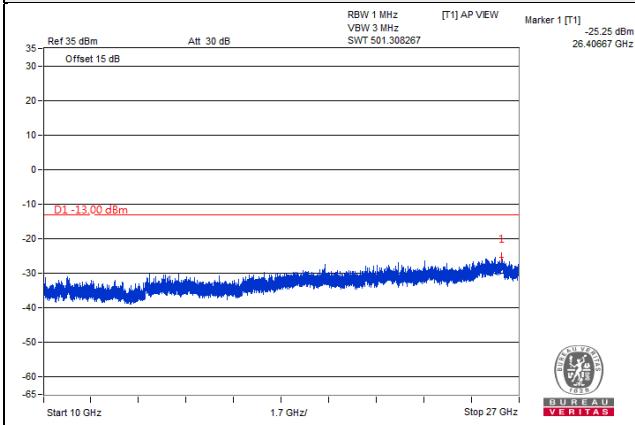

*The 9kHz signal over the limit is from Spectrum.

Channel Bandwidth: 15MHz

Channel 20325 (1747.5MHz)

Frequency Range : 9kHz~1GHz

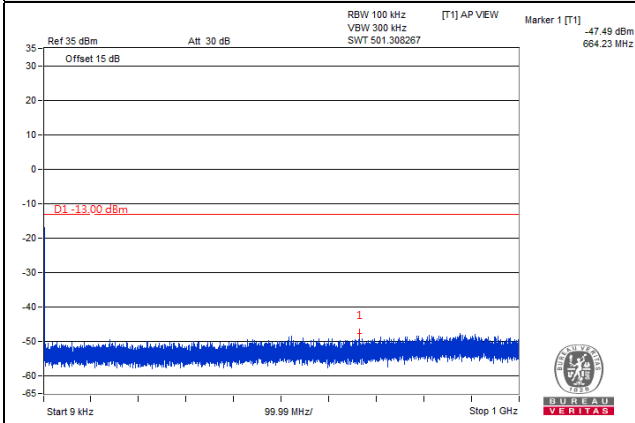

Frequency Range : 1GHz~10GHz

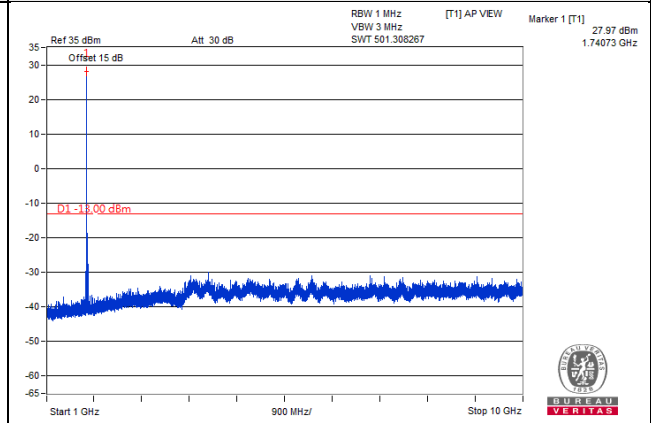

Frequency Range : 10GHz~27GHz

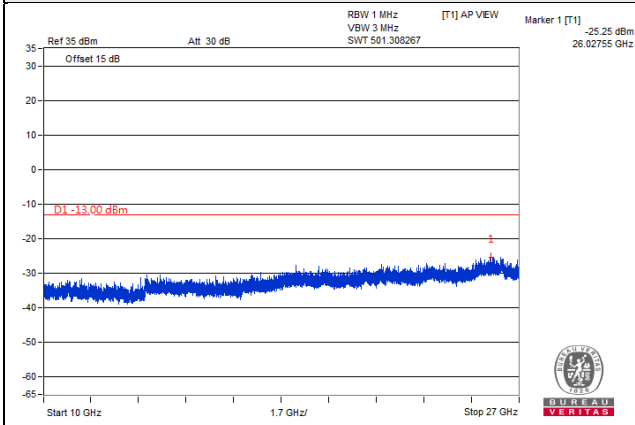

*The 9kHz signal over the limit is from Spectrum.

Channel Bandwidth: 20MHz

Channel 20050 (1720.0MHz)

Frequency Range : 9kHz~1GHz

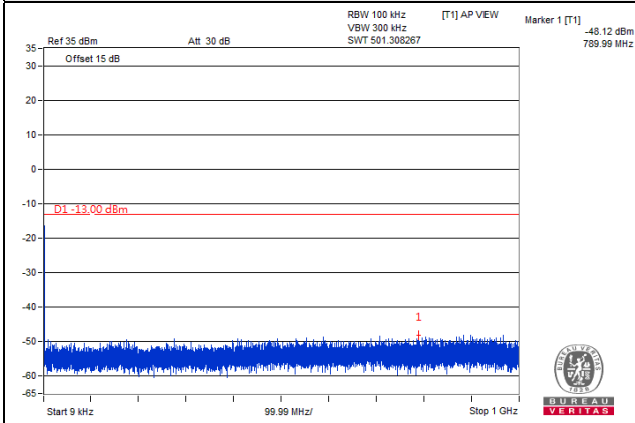

Frequency Range : 1GHz~10GHz

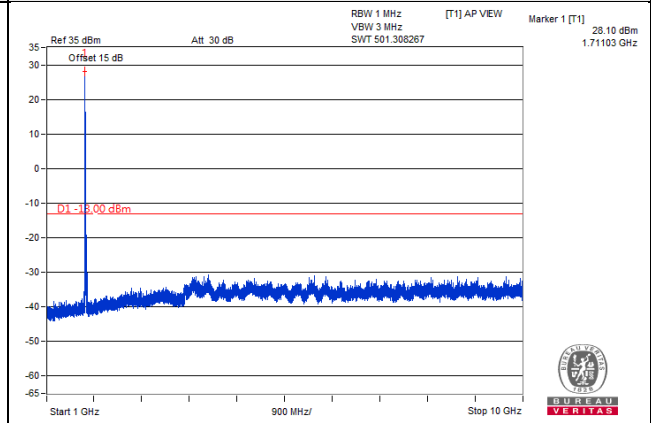

Frequency Range : 10GHz~27GHz

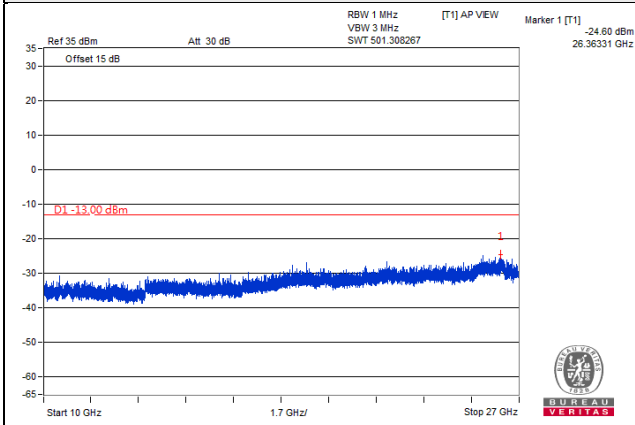

*The 9kHz signal over the limit is from Spectrum.

Channel Bandwidth: 20MHz

Channel 20175 (1732.5MHz)

Frequency Range : 9kHz~1GHz

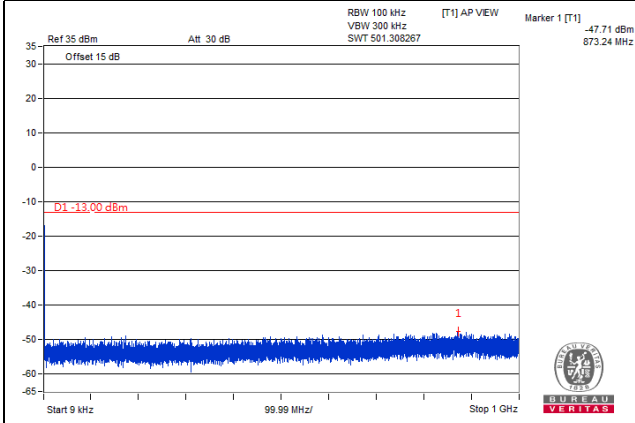

Frequency Range : 1GHz~10GHz

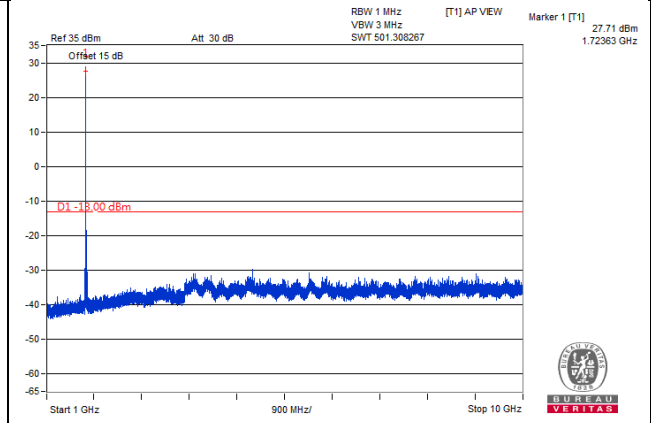

Frequency Range : 10GHz~27GHz

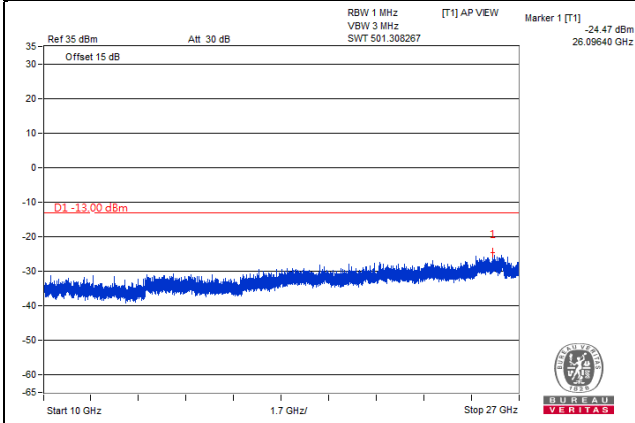

*The 9kHz signal over the limit is from Spectrum.

Channel Bandwidth: 20MHz

Channel 20300 (1745.0MHz)

Frequency Range : 9kHz~1GHz

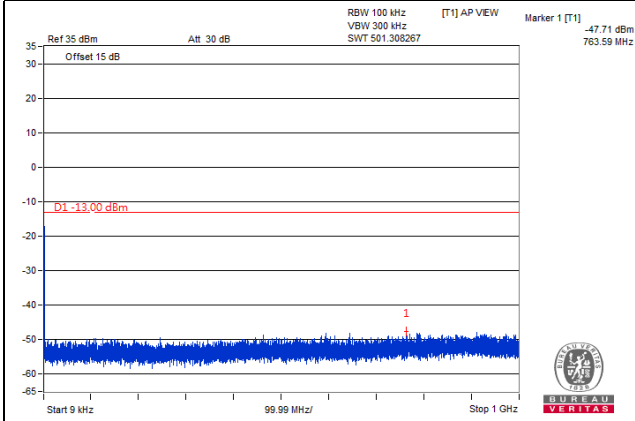

Frequency Range : 1GHz~10GHz

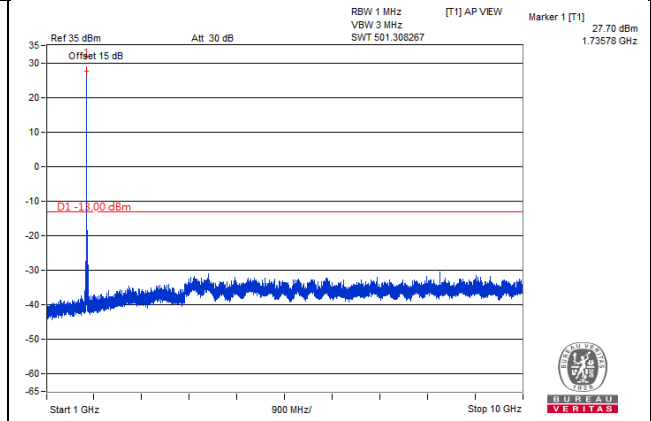

Frequency Range : 10GHz~27GHz

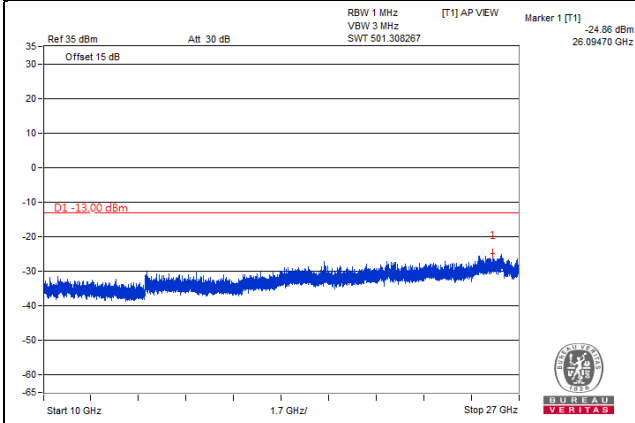

*The 9kHz signal over the limit is from Spectrum.

LTE Band 7

Channel Band width: 5MHz

Channel 20775(2502.5MHz)

Frequency Range : 9kHz~1GHz

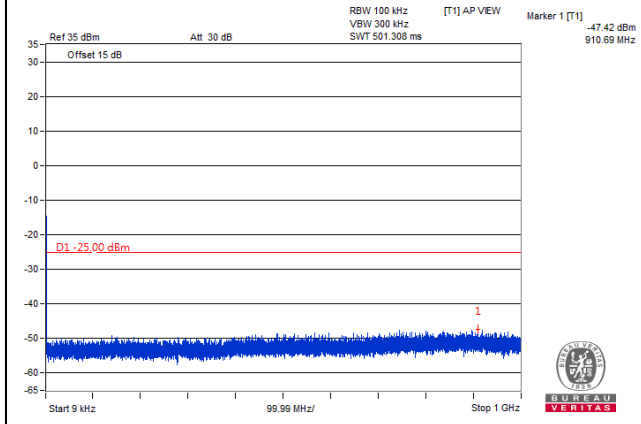

Frequency Range : 1GHz~3GHz

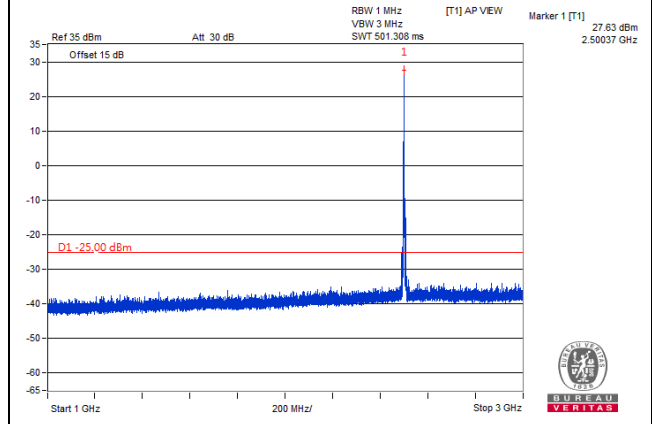

Frequency Range : 3GHz~27GHz

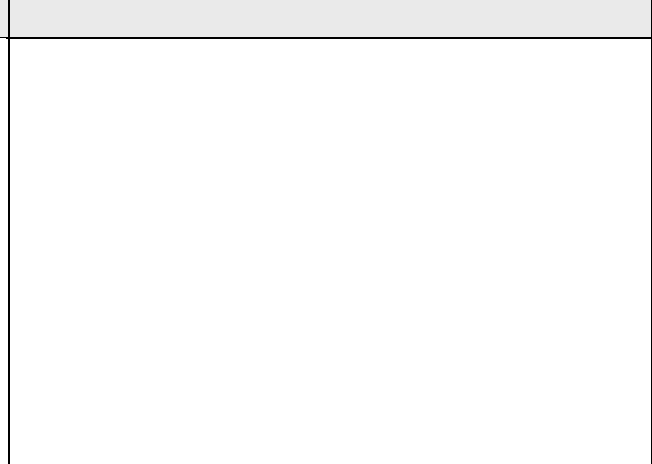
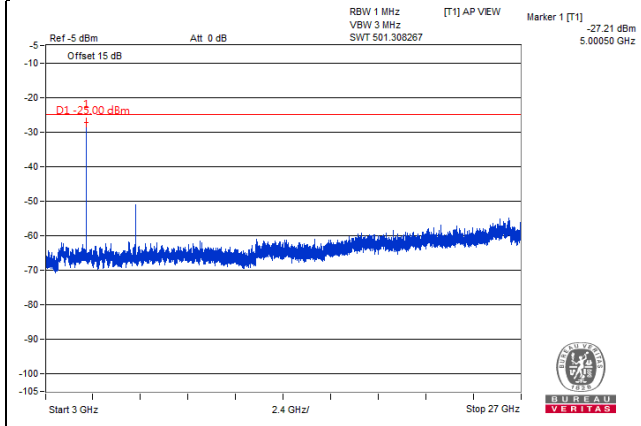

*The 9kHz signal over the limit is from Spectrum.

Channel Band width: 5MHz

Channel 21100(2535MHz)

Frequency Range : 9kHz~1GHz

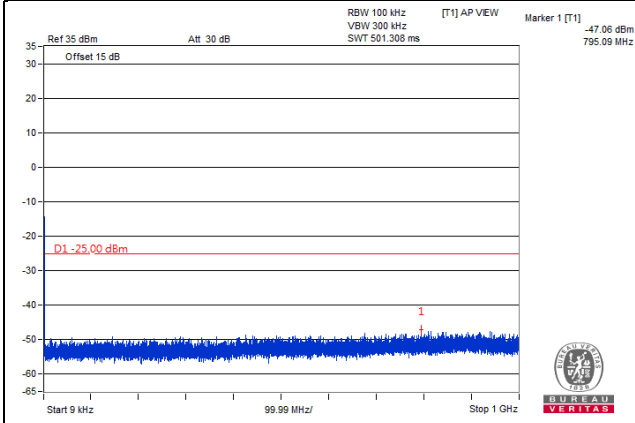

Frequency Range : 1GHz~3GHz

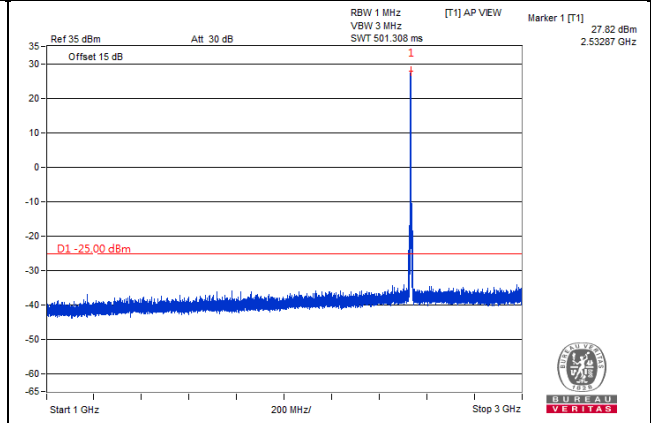

Frequency Range : 3GHz~27GHz

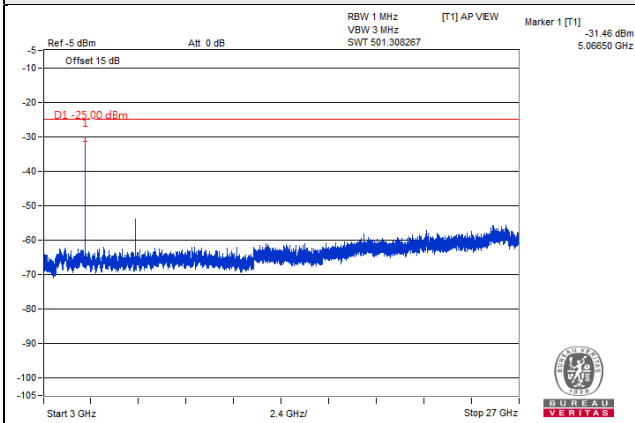

*The 9kHz signal over the limit is from Spectrum.

Channel Band width: 5MHz

Channel 21425(2567.5MHz)

Frequency Range : 9kHz~1GHz

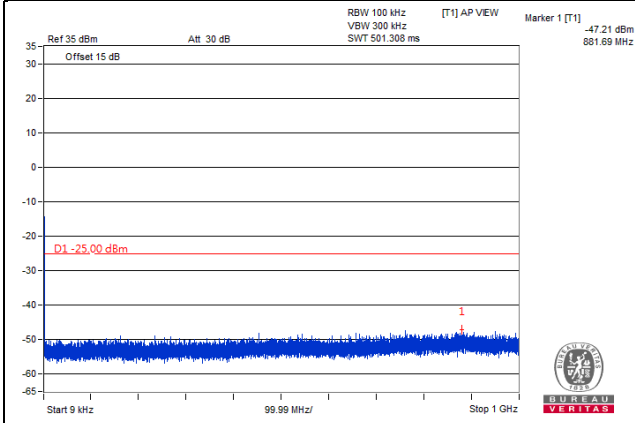

Frequency Range : 1GHz~3GHz

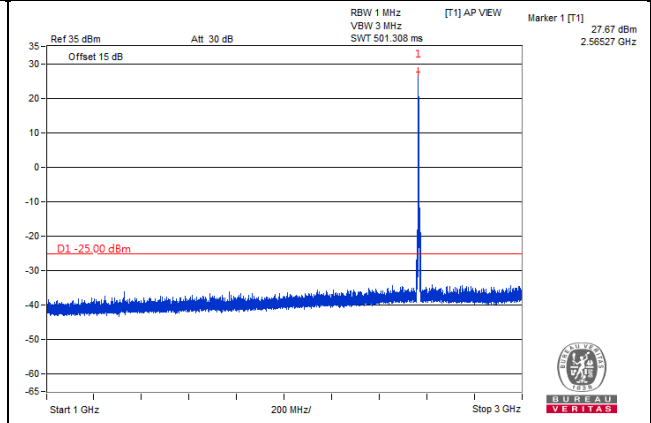

Frequency Range : 3GHz~27GHz

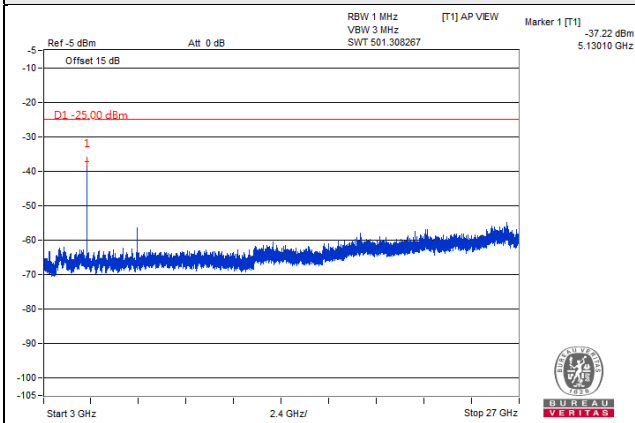

*The 9kHz signal over the limit is from Spectrum.

Channel Band width: 10MHz

Channel 20800(2505MHz)

Frequency Range : 9kHz~1GHz

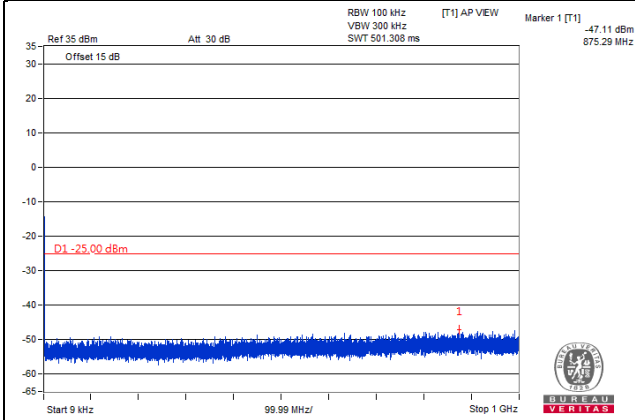

Frequency Range : 1GHz~3GHz

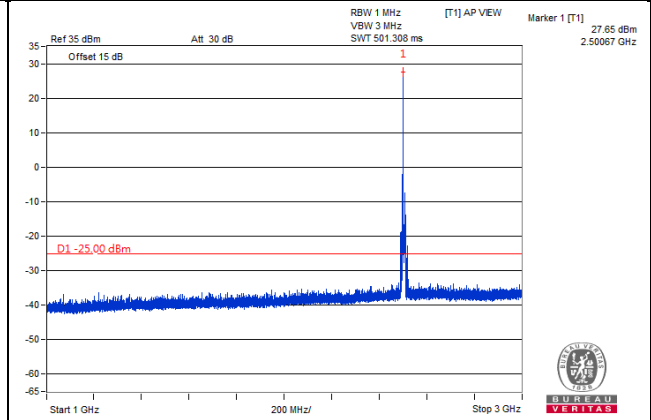

Frequency Range : 3GHz~27GHz

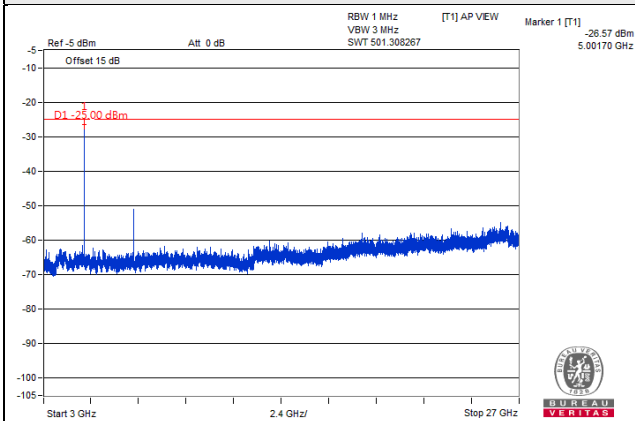

*The 9kHz signal over the limit is from Spectrum.

Channel Band width: 10MHz

Channel 21100(2535MHz)

Frequency Range : 9kHz~1GHz

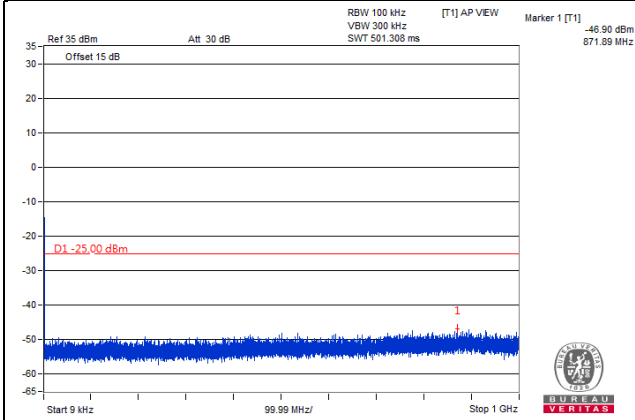

Frequency Range : 1GHz~3GHz

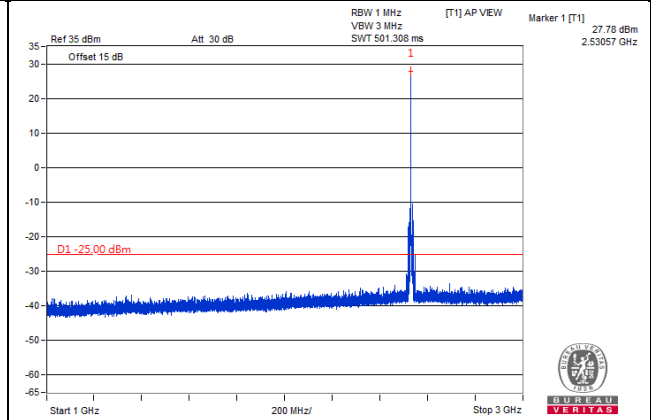

Frequency Range : 3GHz~27GHz

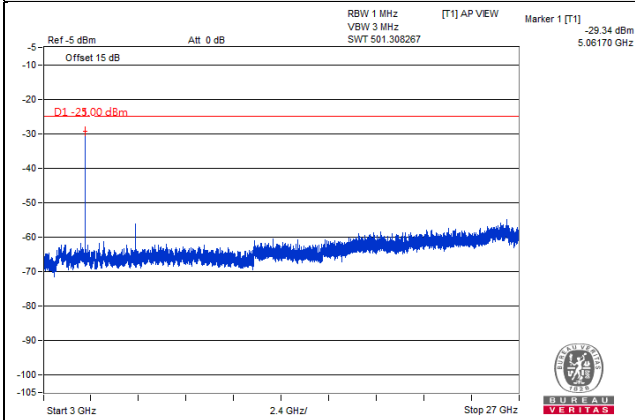

*The 9kHz signal over the limit is from Spectrum.

Channel Band width: 10MHz

Channel 21400(2565MHz)

Frequency Range : 9kHz~1GHz

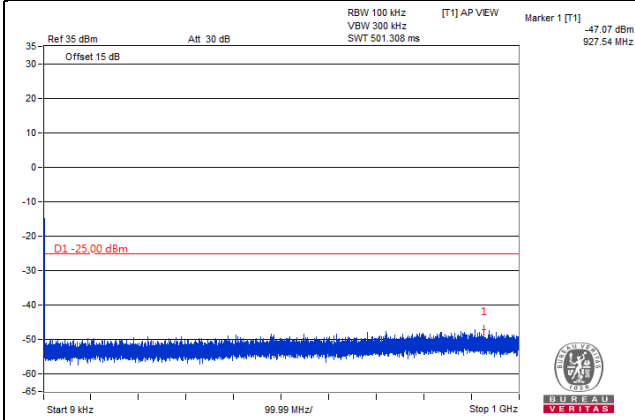

Frequency Range : 1GHz~3GHz

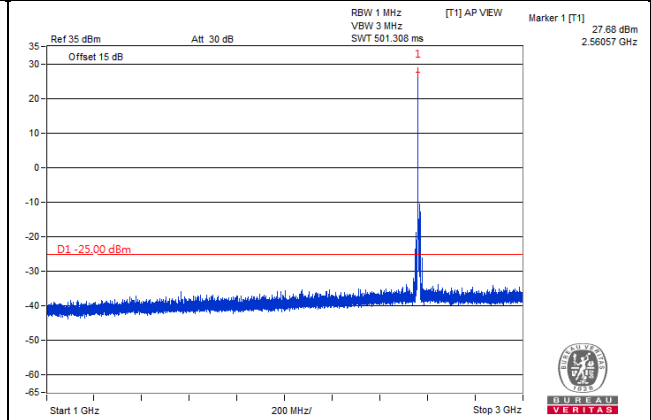

Frequency Range : 3GHz~27GHz

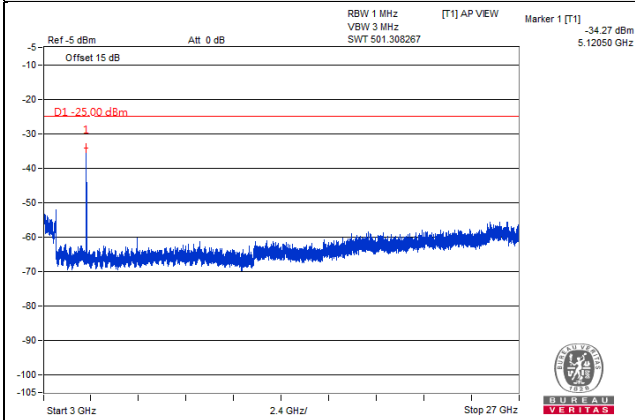

*The 9kHz signal over the limit is from Spectrum.

Channel Band width: 15MHz

Channel 20825(2507.5MHz)

Frequency Range : 9kHz~1GHz

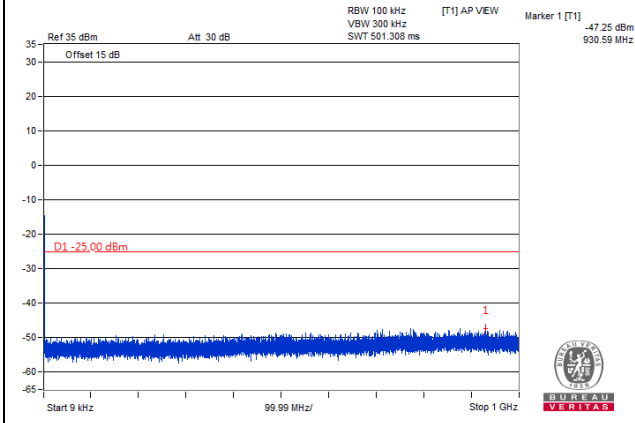

Frequency Range : 1GHz~3GHz

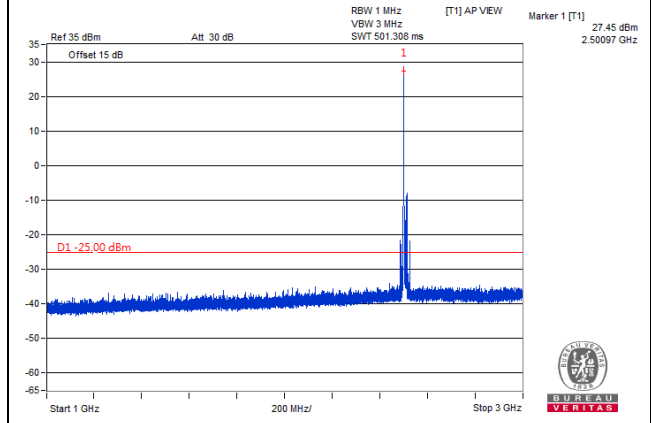

Frequency Range : 3GHz~27GHz

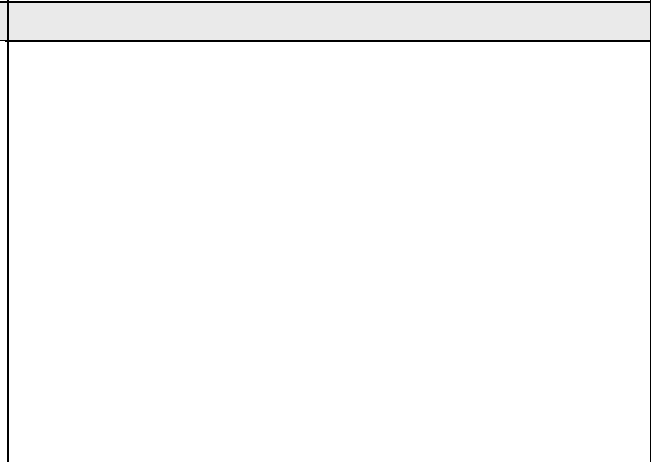
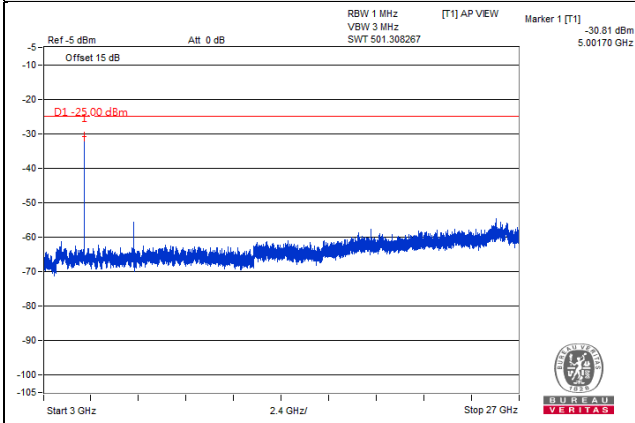

*The 9kHz signal over the limit is from Spectrum.

Channel Band width: 15MHz

Channel 21100(2535MHz)

Frequency Range : 9kHz~1GHz

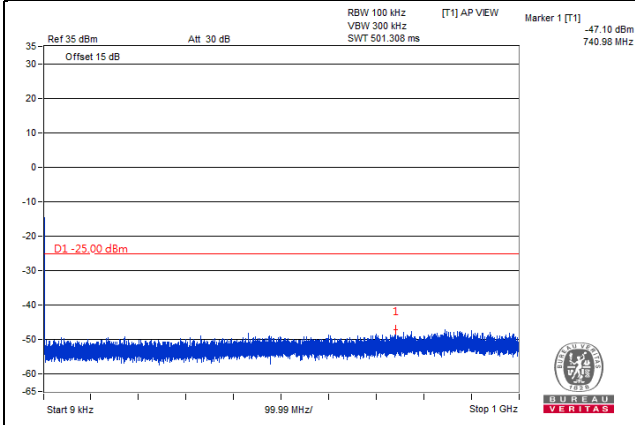

Frequency Range : 1GHz~3GHz

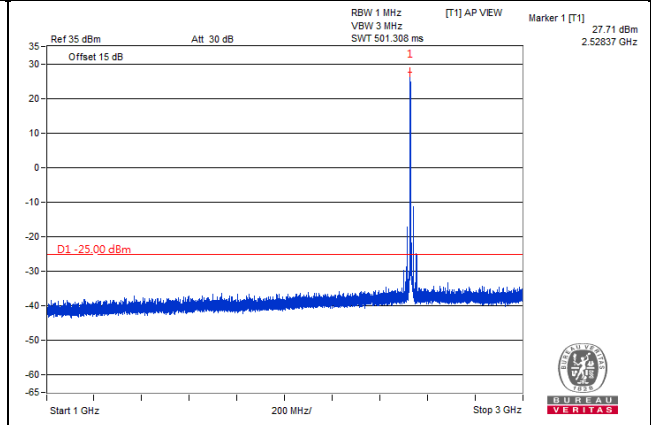

Frequency Range : 3GHz~27GHz

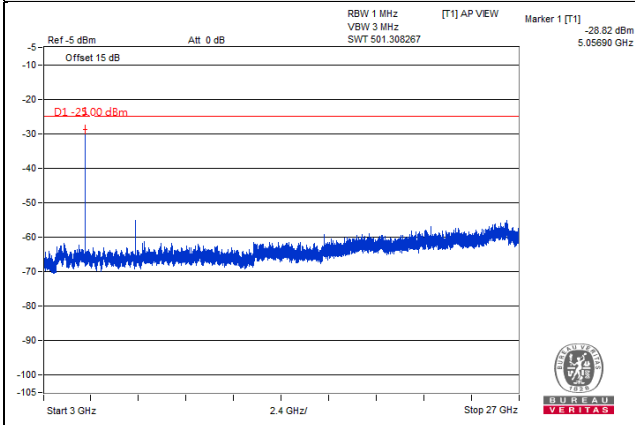

*The 9kHz signal over the limit is from Spectrum.

Channel Band width: 15MHz

Channel 21375(2562.5MHz)

Frequency Range : 9kHz~1GHz

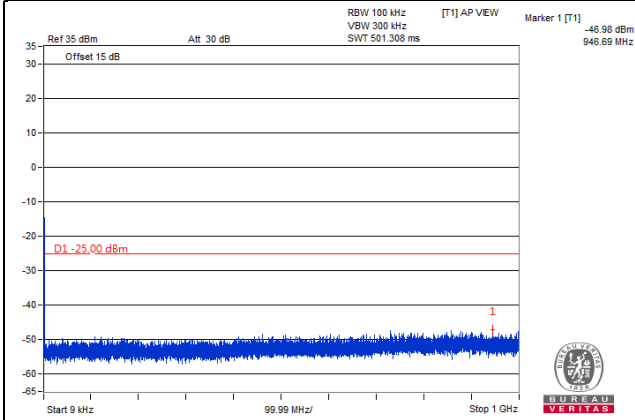

Frequency Range : 1GHz~3GHz

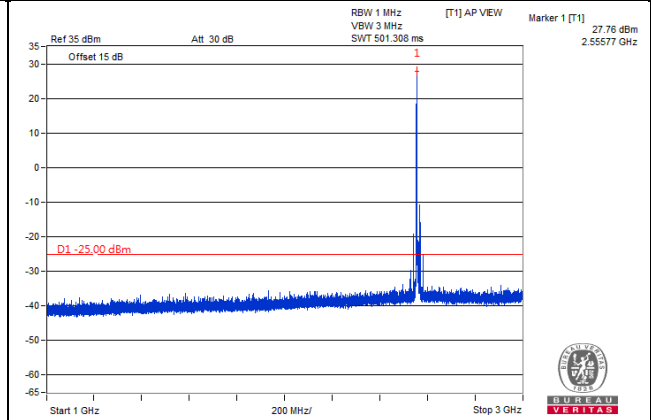

Frequency Range : 3GHz~27GHz

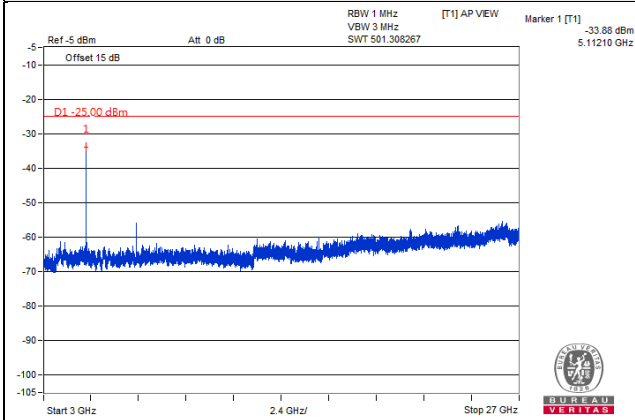

*The 9kHz signal over the limit is from Spectrum.

Channel Band width: 20MHz

Channel 20850(2510MHz)

Frequency Range : 9kHz~1GHz

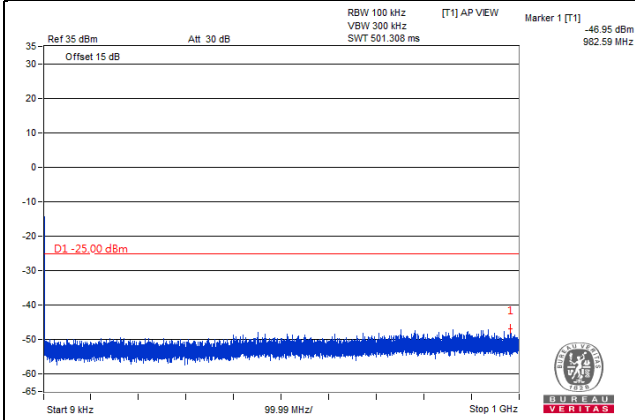

Frequency Range : 1GHz~3GHz

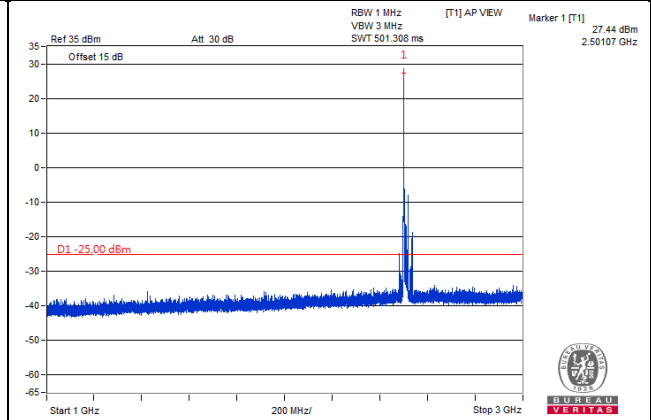

Frequency Range : 3GHz~27GHz

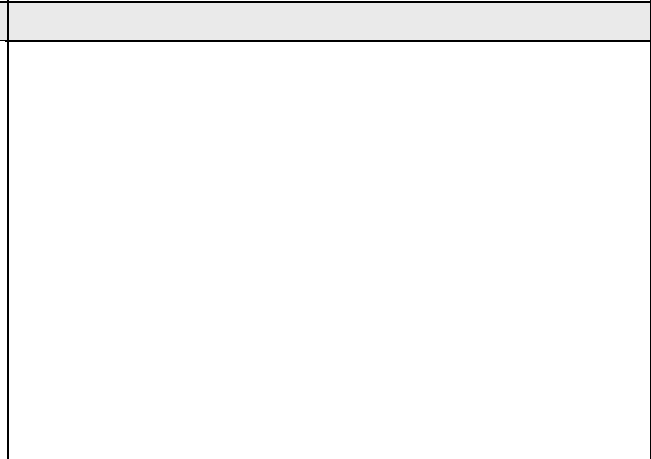
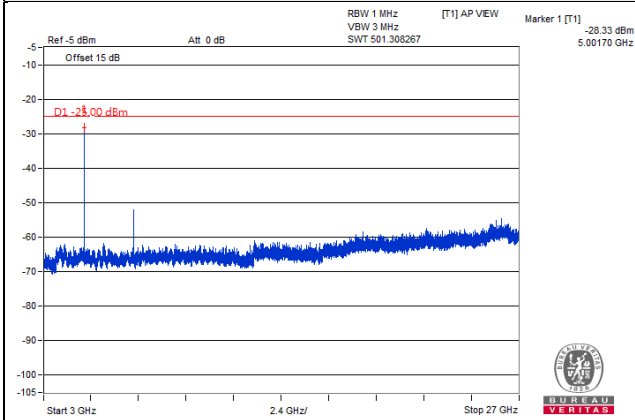

*The 9kHz signal over the limit is from Spectrum.

Channel Band width: 20MHz

Channel 21100(2535MHz)

Frequency Range : 9kHz~1GHz

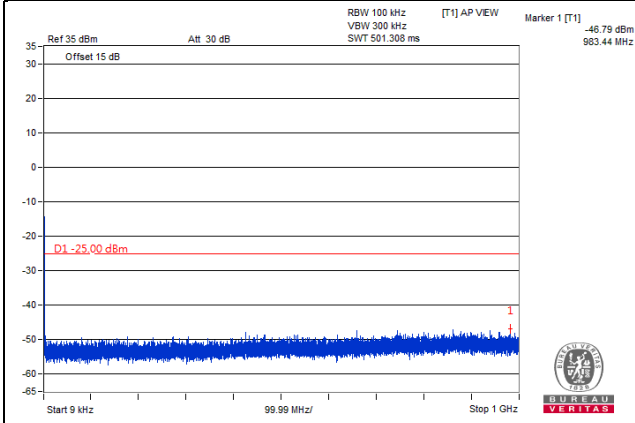

Frequency Range : 1GHz~3GHz

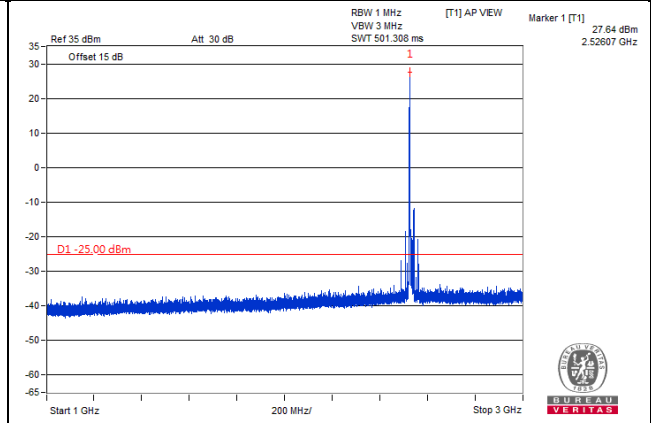

Frequency Range : 3GHz~27GHz

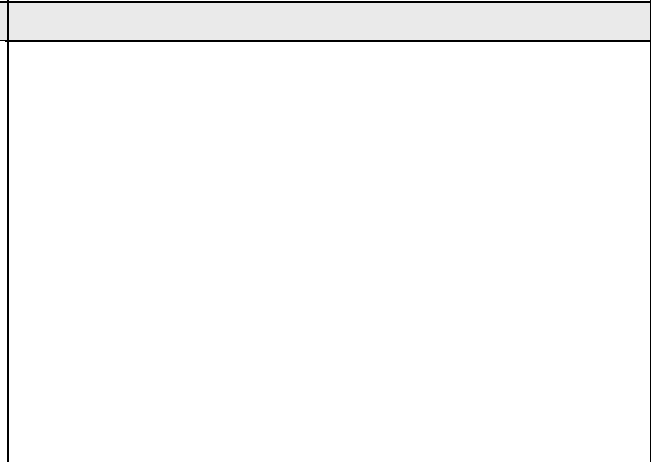
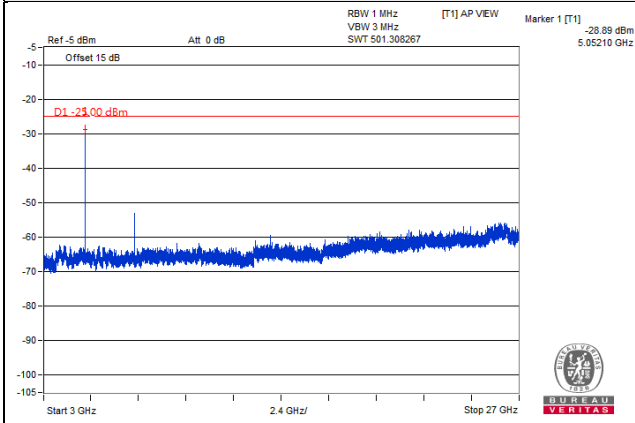

*The 9kHz signal over the limit is from Spectrum.

Channel Band width: 20MHz

Channel 21350(2560MHz)

Frequency Range : 9kHz~1GHz

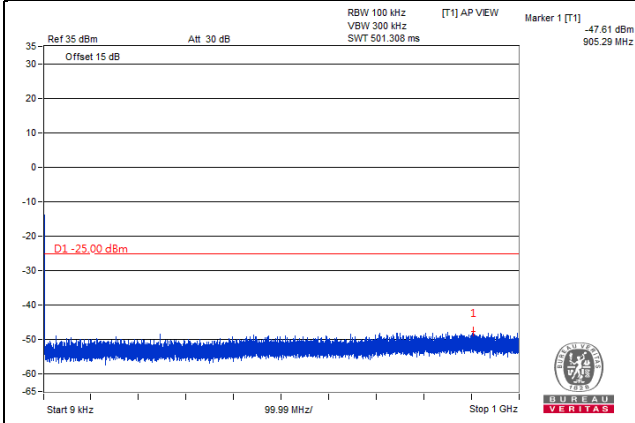

Frequency Range : 1GHz~3GHz

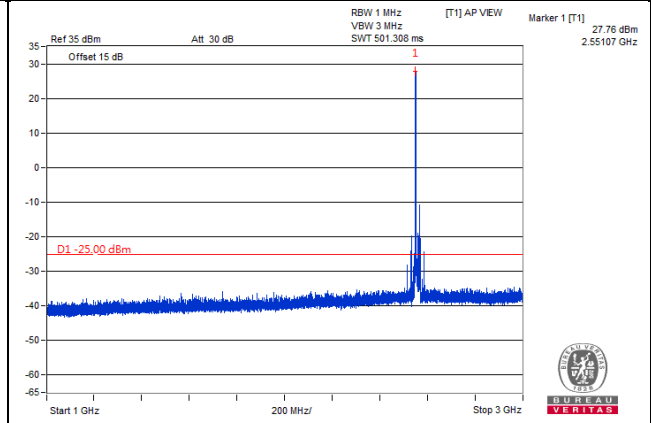

Frequency Range : 3GHz~27GHz

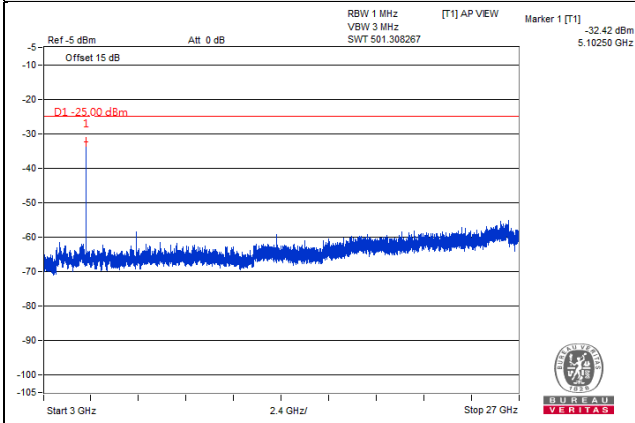

*The 9kHz signal over the limit is from Spectrum.

4.8 Radiated Emission Measurement

4.8.1 Limits of Radiated Emission Measurement

For WCDMA Band 4, LTE Band 4

According to FCC 27.53(h) for operations in the 1695-1710 MHz, 1710-1755 MHz, 1755-1780 MHz, 1915-1920 MHz, 1995-2000 MHz, 2000-2020 MHz, 2110-2155 MHz, 2155-2180 MHz, and 2180-2200 bands, the power of any emission outside a licensee's frequency block shall be attenuated below the transmitter power (P) in watts by at least $43 + 10 \log (P)$ dB.

For LTE Band 7

In the FCC 27.53(m) (4)(6), On any frequency outside a licensee's frequency block, The power of any emission shall be attenuated below the transmitter power (P) by at least $55 + 10 \log (P)$ dB. The emission limit equal to -25dBm .

4.8.2 Test Procedure

- a. The power was measured with R&S Spectrum Analyzer. All measurements were done at 3 channels (low, middle and high channel of operational frequency range.)
- b. Substitution method is used for E.I.R.P measurement. In the semi-anechoic chamber, EUT placed on the 0.8m height of Turn Table, rotated the table around 360 degrees to search the maximum radiation power and receiver antenna shall be rotated vertical and horizontal polarization and moved height from 1m to 4m to find the maximum polar radiated power. The "Read Value" is the spectrum reading the maximum power value.
- c. The substitution antenna is substituted for EUT at the same position and signals generator export the CW signal to the substitution antenna via a TX cable. Rotated the Turn Table and moved receiving antenna to find the maximum radiation power. Adjust output power level of S.G to get a Value of spectrum reading equal to "Read Value" of step b. Record the power level of S.G
- d. $\text{EIRP} = \text{Output power level of S.G} - \text{TX cable loss} + \text{Antenna gain of substitution antenna}$.

Note: The resolution bandwidth and video bandwidth of test receiver/spectrum analyzer is 1MHz/3MHz.

4.8.3 Deviation from Test Standard

No deviation.

4.8.4 Test Setup

For radiated emission 30MHz to 1GHz

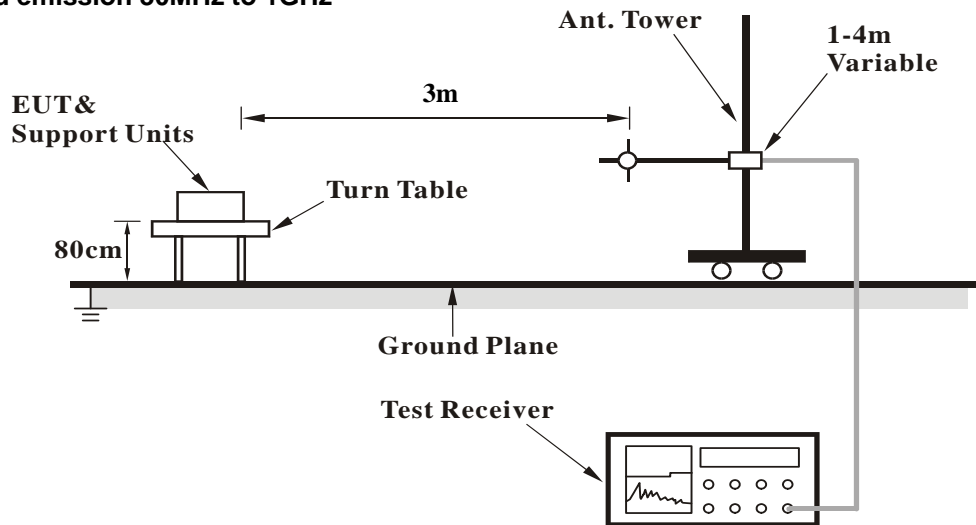

For radiated emission above 1GHz

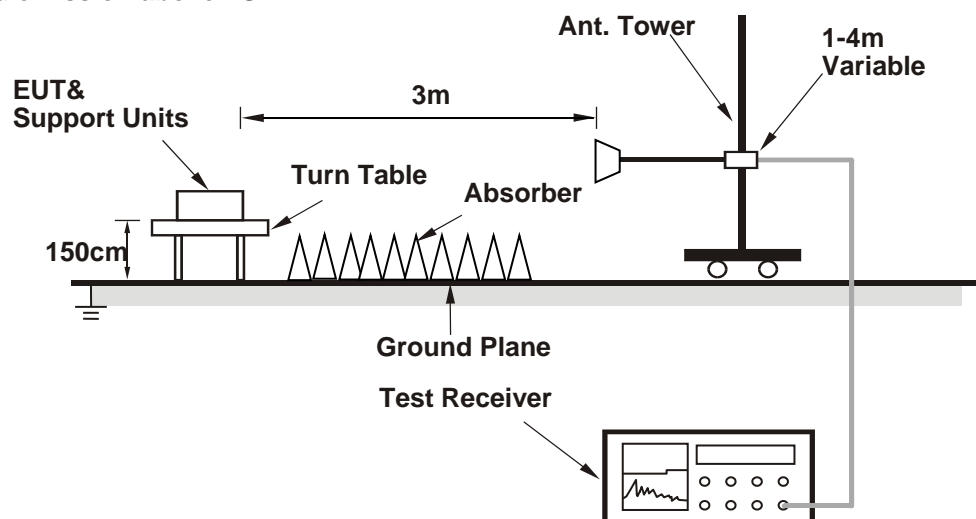

For the actual test configuration, please refer to the attached file (Test Setup Photo).

4.8.5 Test Results

Below 1GHz
WCDMA Band 4

Mode	TX channel 1513 (1752.6MHz)	Frequency Range	Below 1000 MHz
Environmental Conditions	22deg. C, 66%RH	Input Power	120Vac, 60Hz
Tested By	Han Wu		

Antenna Polarity & Test Distance: Horizontal at 3 M							
No.	Freq. (MHz)	Reading (dBm)	S.G Power Value (dBm)	Correction Factor (dB)	EIRP (dBm)	Limit (dBm)	Margin (dB)
1	62.98	-52.4	-55.9	-2.4	-58.3	-13.0	-45.3
2	136.70	-61.0	-63.8	-3.2	-67.0	-13.0	-54.0
3	153.19	-60.2	-61.5	-2.9	-64.4	-13.0	-51.4
4	208.48	-58.5	-64.9	-2.0	-66.9	-13.0	-53.9
5	249.22	-54.3	-59.4	-1.4	-60.8	-13.0	-47.8
6	313.24	-61.9	-70.0	4.0	-66.0	-13.0	-53.0

Remarks:

1. EIRP (dBm) = S.G Value (dBm) + Correction Factor (dB).
2. Correction Factor (dB) = Substitution Antenna Gain (dB) + Cable Loss (dB).

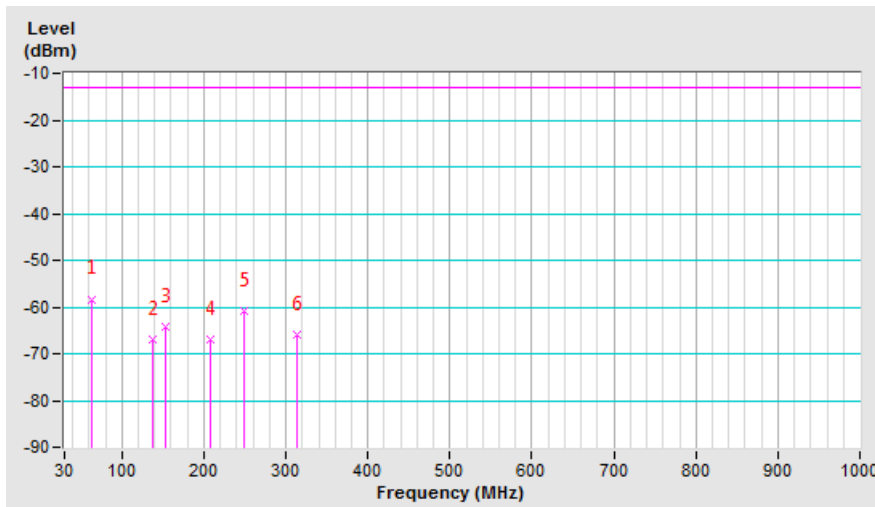

Mode	TX channel 1513 (1752.6MHz)	Frequency Range	Below 1000 MHz
Environmental Conditions	22deg. C, 66%RH	Input Power	120Vac, 60Hz
Tested By	Han Wu		

Antenna Polarity & Test Distance: Vertical at 3 M							
No.	Freq. (MHz)	Reading (dBm)	S.G Power Value (dBm)	Correction Factor (dB)	EIRP (dBm)	Limit (dBm)	Margin (dB)
1	30.00	-41.1	-31.6	-19.4	-51.0	-13.0	-38.0
2	66.86	-49.9	-55.6	-1.5	-57.1	-13.0	-44.1
3	136.70	-64.8	-64.8	-3.2	-68.0	-13.0	-55.0
4	208.48	-61.2	-62.2	-2.0	-64.2	-13.0	-51.2
5	306.45	-66.7	-70.5	3.9	-66.6	-13.0	-53.6
6	426.73	-66.0	-69.9	3.5	-66.4	-13.0	-53.4

Remarks:

1. EIRP (dBm) = S.G Value (dBm) + Correction Factor (dB).
2. Correction Factor (dB) = Substitution Antenna Gain (dB) + Cable Loss (dB).

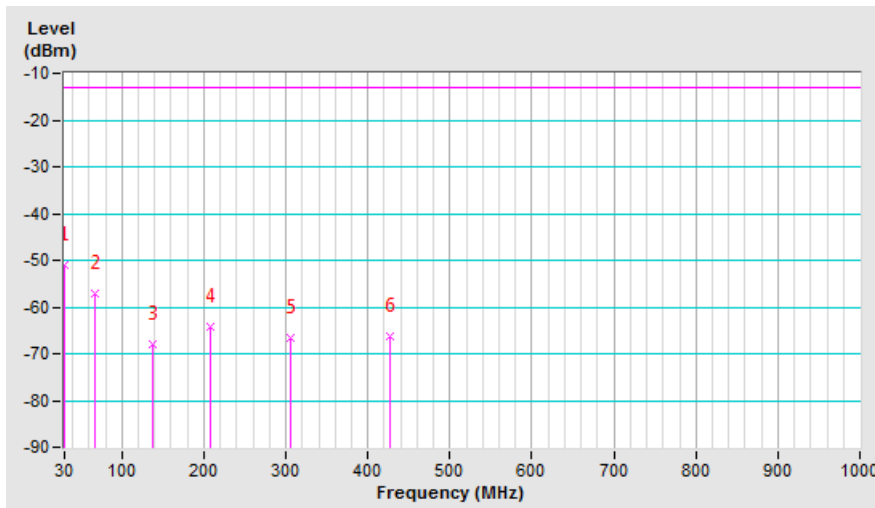

LTE Band 4, Channel Bandwidth: 1.4MHz

Mode	TX channel 19957 (1710.7MHz)	Frequency Range	Below 1000 MHz
Environmental Conditions	22deg. C, 66%RH	Input Power	120Vac, 60Hz
Tested By	Han Wu		

Antenna Polarity & Test Distance: Horizontal at 3 M							
No.	Freq. (MHz)	Reading (dBm)	S.G Power Value (dBm)	Correction Factor (dB)	EIRP (dBm)	Limit (dBm)	Margin (dB)
1	66.86	-52.5	-57.9	-1.5	-59.4	-13.0	-46.4
2	138.64	-60.5	-63.3	-3.2	-66.5	-13.0	-53.5
3	152.22	-61.5	-62.9	-2.8	-65.7	-13.0	-52.7
4	208.48	-56.6	-63.0	-2.0	-65.0	-13.0	-52.0
5	242.43	-50.7	-56.2	-1.4	-57.6	-13.0	-44.6
6	305.48	-63.9	-72.1	3.8	-68.3	-13.0	-55.3

Remarks:

1. EIRP (dBm) = S.G Value (dBm) + Correction Factor (dB).
2. Correction Factor (dB) = Substitution Antenna Gain (dB) + Cable Loss (dB).

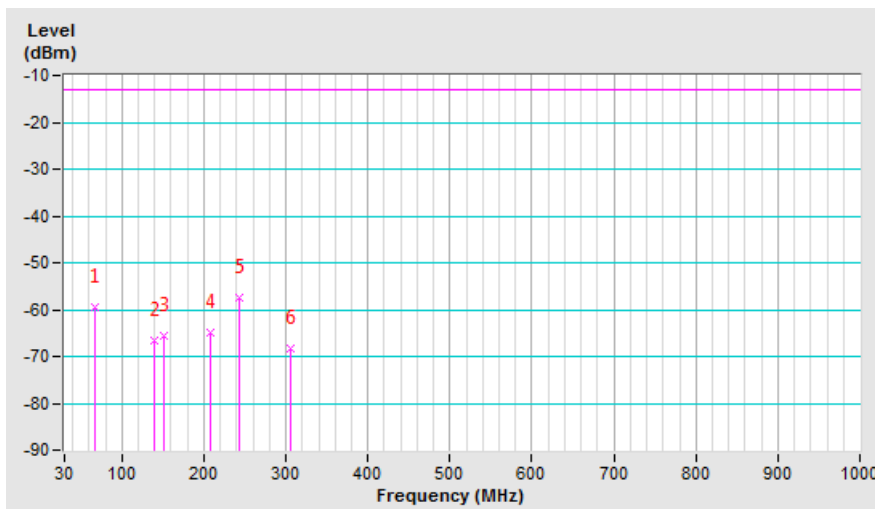

Mode	TX channel 19957 (1710.7MHz)	Frequency Range	Below 1000 MHz
Environmental Conditions	22deg. C, 66%RH	Input Power	120Vac, 60Hz
Tested By	Han Wu		

Antenna Polarity & Test Distance: Vertical at 3 M							
No.	Freq. (MHz)	Reading (dBm)	S.G Power Value (dBm)	Correction Factor (dB)	EIRP (dBm)	Limit (dBm)	Margin (dB)
1	30.97	-41.5	-32.9	-18.8	-51.7	-13.0	-38.7
2	66.86	-43.5	-49.2	-1.5	-50.7	-13.0	-37.7
3	128.94	-55.8	-58.0	-3.2	-61.2	-13.0	-48.2
4	227.88	-42.7	-44.8	-1.7	-46.5	-13.0	-33.5
5	262.80	-51.5	-48.9	-1.6	-50.5	-13.0	-37.5
6	359.80	-63.2	-67.6	4.0	-63.6	-13.0	-50.6

Remarks:

1. EIRP (dBm) = S.G Value (dBm) + Correction Factor (dB).
2. Correction Factor (dB) = Substitution Antenna Gain (dB) + Cable Loss (dB).

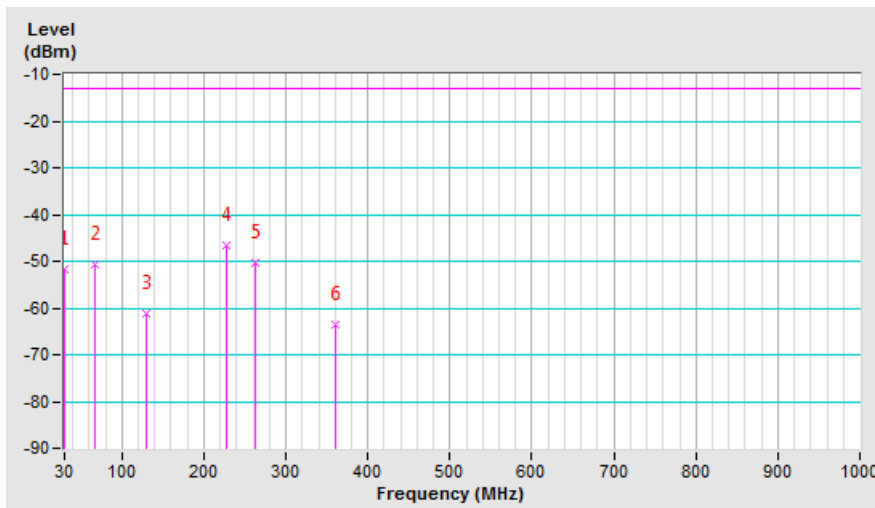

LTE Band 4, Channel Bandwidth: 5MHz

Mode	TX channel 19975 (1712.5MHz)	Frequency Range	Below 1000 MHz
Environmental Conditions	22deg. C, 66%RH	Input Power	120Vac, 60Hz
Tested By	Han Wu		

Antenna Polarity & Test Distance: Horizontal at 3 M							
No.	Freq. (MHz)	Reading (dBm)	S.G Power Value (dBm)	Correction Factor (dB)	EIRP (dBm)	Limit (dBm)	Margin (dB)
1	66.86	-51.6	-57.0	-1.5	-58.5	-13.0	-45.5
2	103.72	-57.6	-64.0	-2.0	-66.0	-13.0	-53.0
3	137.67	-59.4	-62.3	-3.2	-65.5	-13.0	-52.5
4	153.19	-60.6	-61.9	-2.9	-64.8	-13.0	-51.8
5	207.51	-59.6	-65.9	-2.0	-67.9	-13.0	-54.9
6	295.78	-64.6	-65.7	-1.8	-67.5	-13.0	-54.5

Remarks:

1. EIRP (dBm) = S.G Value (dBm) + Correction Factor (dB).
2. Correction Factor (dB) = Substitution Antenna Gain (dB) + Cable Loss (dB).

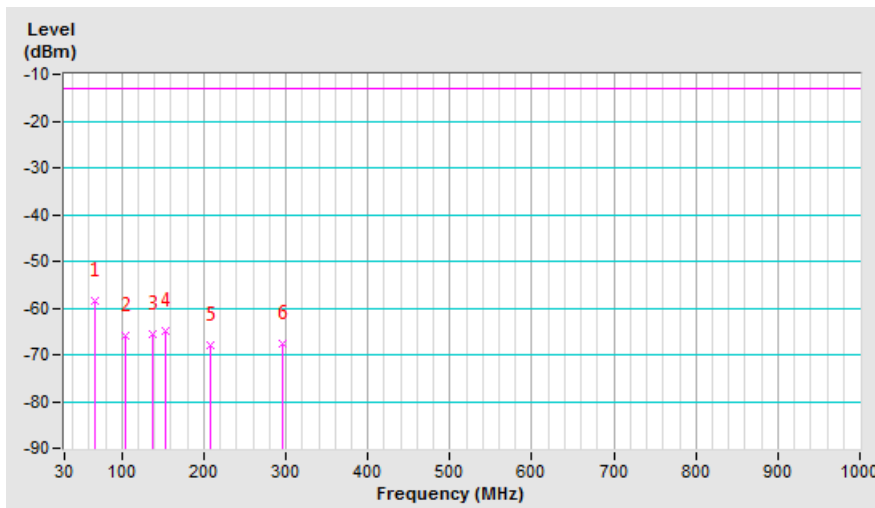

Mode	TX channel 19975 (1712.5MHz)	Frequency Range	Below 1000 MHz
Environmental Conditions	22deg. C, 66%RH	Input Power	120Vac, 60Hz
Tested By	Han Wu		

Antenna Polarity & Test Distance: Vertical at 3 M							
No.	Freq. (MHz)	Reading (dBm)	S.G Power Value (dBm)	Correction Factor (dB)	EIRP (dBm)	Limit (dBm)	Margin (dB)
1	35.82	-49.3	-43.1	-15.9	-59.0	-13.0	-46.0
2	66.86	-43.3	-49.0	-1.5	-50.5	-13.0	-37.5
3	128.94	-60.2	-62.4	-3.2	-65.6	-13.0	-52.6
4	156.10	-67.8	-67.7	-2.9	-70.6	-13.0	-57.6
5	207.51	-59.8	-60.6	-2.0	-62.6	-13.0	-49.6
6	313.24	-66.5	-70.6	4.0	-66.6	-13.0	-53.6

Remarks:

1. EIRP (dBm) = S.G Value (dBm) + Correction Factor (dB).
2. Correction Factor (dB) = Substitution Antenna Gain (dB) + Cable Loss (dB).

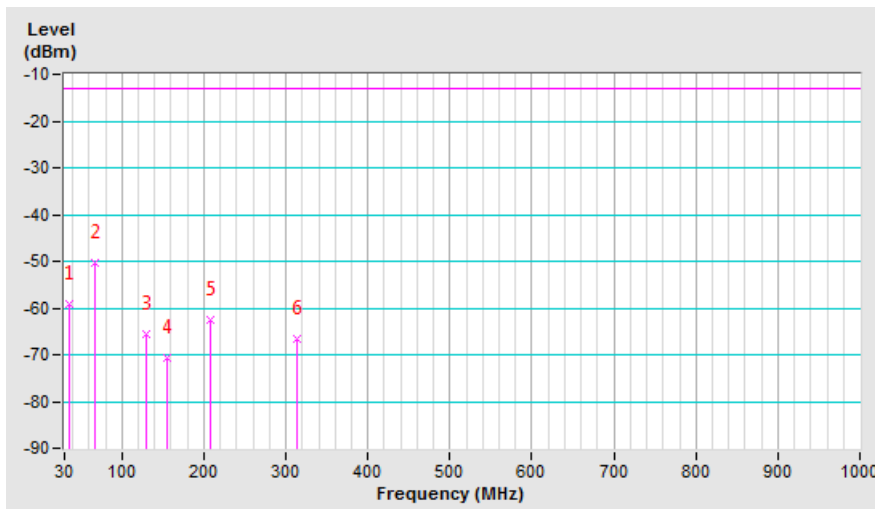

LTE Band 4, Channel Bandwidth: 20MHz

Mode	TX channel 20050 (1720.0MHz)	Frequency Range	Below 1000 MHz
Environmental Conditions	22deg. C, 66%RH	Input Power	120Vac, 60Hz
Tested By	Han Wu		

Antenna Polarity & Test Distance: Horizontal at 3 M

No.	Freq. (MHz)	Reading (dBm)	S.G Power Value (dBm)	Correction Factor (dB)	EIRP (dBm)	Limit (dBm)	Margin (dB)
1	67.83	-51.9	-57.6	-1.0	-58.6	-13.0	-45.6
2	101.78	-56.3	-63.0	-1.6	-64.6	-13.0	-51.6
3	136.70	-54.7	-57.5	-3.2	-60.7	-13.0	-47.7
4	186.17	-58.8	-64.4	-2.6	-67.0	-13.0	-54.0
5	203.63	-58.5	-64.4	-2.1	-66.5	-13.0	-53.5
6	391.81	-63.8	-67.6	3.4	-64.2	-13.0	-51.2

Remarks:

1. EIRP (dBm) = S.G Value (dBm) + Correction Factor (dB).
2. Correction Factor (dB) = Substitution Antenna Gain (dB) + Cable Loss (dB).

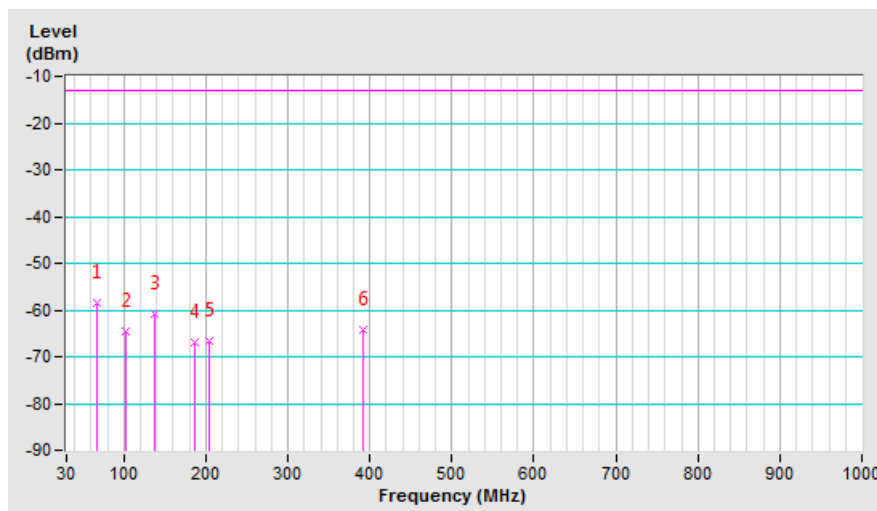

Mode	TX channel 20050 (1720.0MHz)	Frequency Range	Below 1000 MHz
Environmental Conditions	22deg. C, 66%RH	Input Power	120Vac, 60Hz
Tested By	Han Wu		

Antenna Polarity & Test Distance: Vertical at 3 M							
No.	Freq. (MHz)	Reading (dBm)	S.G Power Value (dBm)	Correction Factor (dB)	EIRP (dBm)	Limit (dBm)	Margin (dB)
1	65.89	-43.2	-48.7	-1.9	-50.6	-13.0	-37.6
2	92.08	-40.8	-47.1	-0.6	-47.7	-13.0	-34.7
3	104.69	-49.1	-55.6	-2.1	-57.7	-13.0	-44.7
4	152.22	-64.5	-63.6	-2.8	-66.4	-13.0	-53.4
5	204.60	-60.1	-60.0	-2.0	-62.0	-13.0	-49.0
6	332.64	-59.5	-64.1	4.0	-60.1	-13.0	-47.1

Remarks:

1. EIRP (dBm) = S.G Value (dBm) + Correction Factor (dB).
2. Correction Factor (dB) = Substitution Antenna Gain (dB) + Cable Loss (dB).

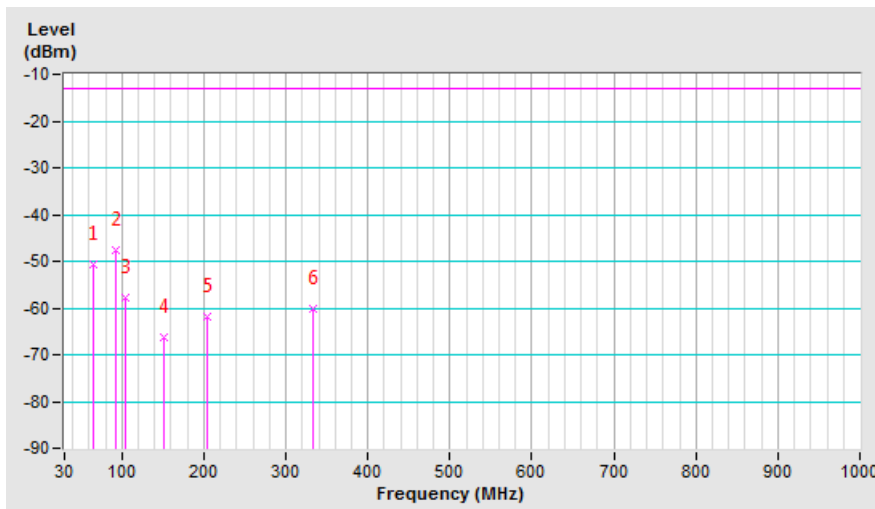

LTE Band 7, Channel Bandwidth: 5MHz

Mode	TX channel 20775 (2502.5MHz)	Frequency Range	Below 1000 MHz
Environmental Conditions	22deg. C, 66%RH	Input Power	120Vac, 60Hz
Tested By	Han Wu		

Antenna Polarity & Test Distance: Horizontal at 3 M							
No.	Freq. (MHz)	Reading (dBm)	S.G Power Value (dBm)	Correction Factor (dB)	EIRP (dBm)	Limit (dBm)	Margin (dB)
1	66.86	-51.3	-56.7	-1.5	-58.2	-25.0	-33.2
2	141.55	-60.5	-62.9	-3.0	-65.9	-25.0	-40.9
3	153.19	-60.4	-61.7	-2.9	-64.6	-25.0	-39.6
4	206.54	-60.0	-66.2	-2.0	-68.2	-25.0	-43.2
5	312.27	-63.5	-71.6	4.0	-67.6	-25.0	-42.6
6	365.62	-59.8	-66.0	3.8	-62.2	-25.0	-37.2

Remarks:

1. EIRP (dBm) = S.G Value (dBm) + Correction Factor (dB).
2. Correction Factor (dB) = Substitution Antenna Gain (dB) + Cable Loss (dB).

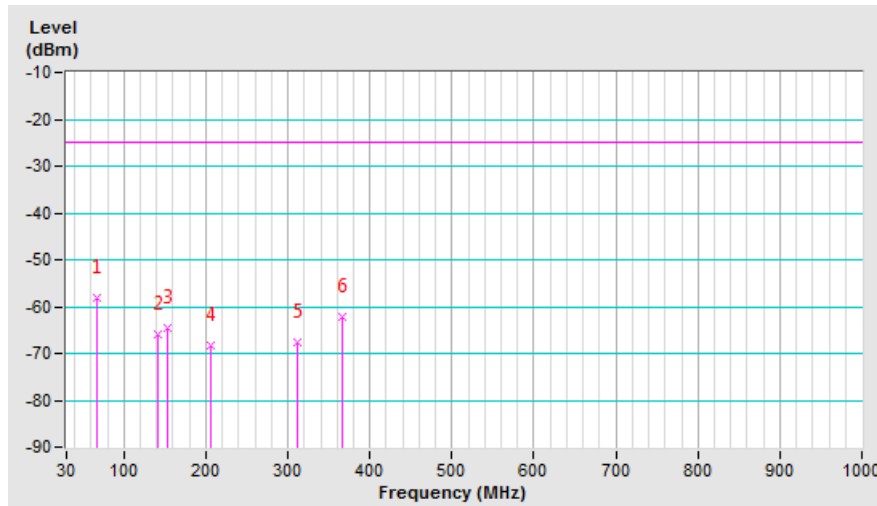

Mode	TX channel 20775 (2502.5MHz)	Frequency Range	Below 1000 MHz
Environmental Conditions	22deg. C, 66%RH	Input Power	120Vac, 60Hz
Tested By	Han Wu		

Antenna Polarity & Test Distance: Vertical at 3 M							
No.	Freq. (MHz)	Reading (dBm)	S.G Power Value (dBm)	Correction Factor (dB)	EIRP (dBm)	Limit (dBm)	Margin (dB)
1	35.82	-49.2	-43.0	-15.9	-58.9	-25.0	-33.9
2	65.89	-44.2	-49.7	-1.9	-51.6	-25.0	-26.6
3	152.22	-63.5	-62.6	-2.8	-65.4	-25.0	-40.4
4	208.48	-61.7	-62.7	-2.0	-64.7	-25.0	-39.7
5	275.41	-71.5	-66.8	-1.6	-68.4	-25.0	-43.4
6	305.48	-67.1	-70.8	3.8	-67.0	-25.0	-42.0

Remarks:

1. EIRP (dBm) = S.G Value (dBm) + Correction Factor (dB).
2. Correction Factor (dB) = Substitution Antenna Gain (dB) + Cable Loss (dB).

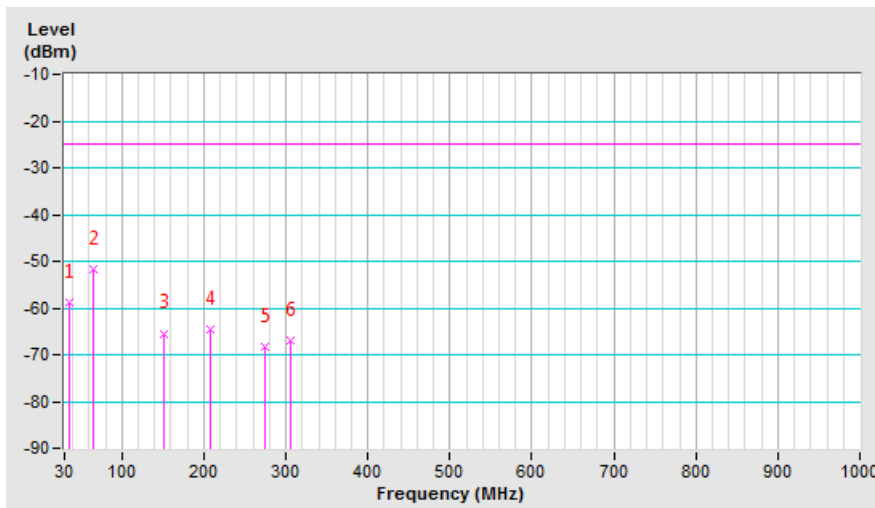

LTE Band 7, Channel Bandwidth: 20MHz

Mode	TX channel 20850 (2510.0MHz)	Frequency Range	Below 1000 MHz
Environmental Conditions	22deg. C, 66%RH	Input Power	120Vac, 60Hz
Tested By	Han Wu		

Antenna Polarity & Test Distance: Horizontal at 3 M							
No.	Freq. (MHz)	Reading (dBm)	S.G Power Value (dBm)	Correction Factor (dB)	EIRP (dBm)	Limit (dBm)	Margin (dB)
1	65.89	-51.7	-56.9	-1.9	-58.8	-25.0	-33.8
2	135.73	-59.3	-62.1	-3.2	-65.3	-25.0	-40.3
3	154.16	-64.7	-66.1	-2.9	-69.0	-25.0	-44.0
4	208.48	-59.6	-66.0	-2.0	-68.0	-25.0	-43.0
5	312.27	-63.6	-71.7	4.0	-67.7	-25.0	-42.7
6	389.87	-65.3	-69.3	3.4	-65.9	-25.0	-40.9

Remarks:

1. EIRP (dBm) = S.G Value (dBm) + Correction Factor (dB).
2. Correction Factor (dB) = Substitution Antenna Gain (dB) + Cable Loss (dB).

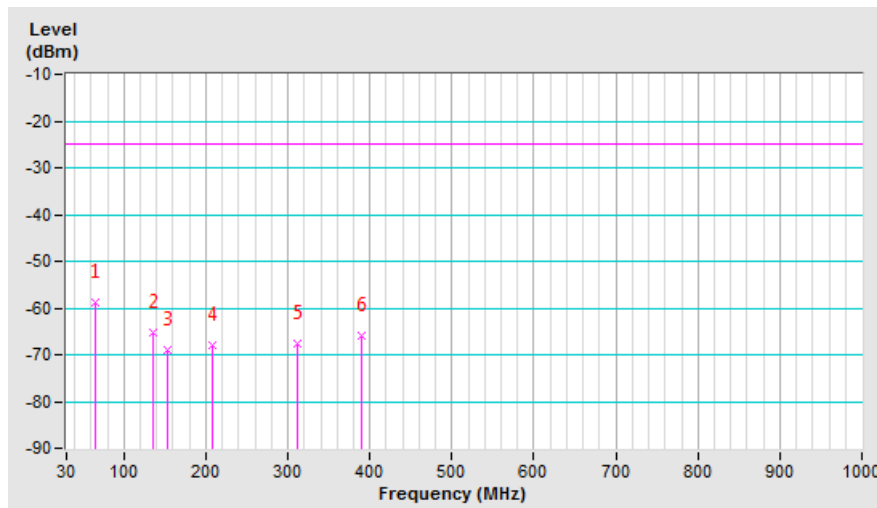

Mode	TX channel 20850 (2510.0MHz)	Frequency Range	Below 1000 MHz
Environmental Conditions	22deg. C, 66%RH	Input Power	120Vac, 60Hz
Tested By	Han Wu		

Antenna Polarity & Test Distance: Vertical at 3 M							
No.	Freq. (MHz)	Reading (dBm)	S.G Power Value (dBm)	Correction Factor (dB)	EIRP (dBm)	Limit (dBm)	Margin (dB)
1	35.82	-46.2	-40.0	-15.9	-55.9	-25.0	-30.9
2	46.49	-45.1	-43.4	-9.9	-53.3	-25.0	-28.3
3	66.86	-44.6	-50.3	-1.5	-51.8	-25.0	-26.8
4	137.67	-64.2	-64.2	-3.2	-67.4	-25.0	-42.4
5	205.57	-61.1	-61.3	-2.0	-63.3	-25.0	-38.3
6	249.22	-63.7	-62.5	-1.4	-63.9	-25.0	-38.9

Remarks:

1. EIRP (dBm) = S.G Value (dBm) + Correction Factor (dB).
2. Correction Factor (dB) = Substitution Antenna Gain (dB) + Cable Loss (dB).

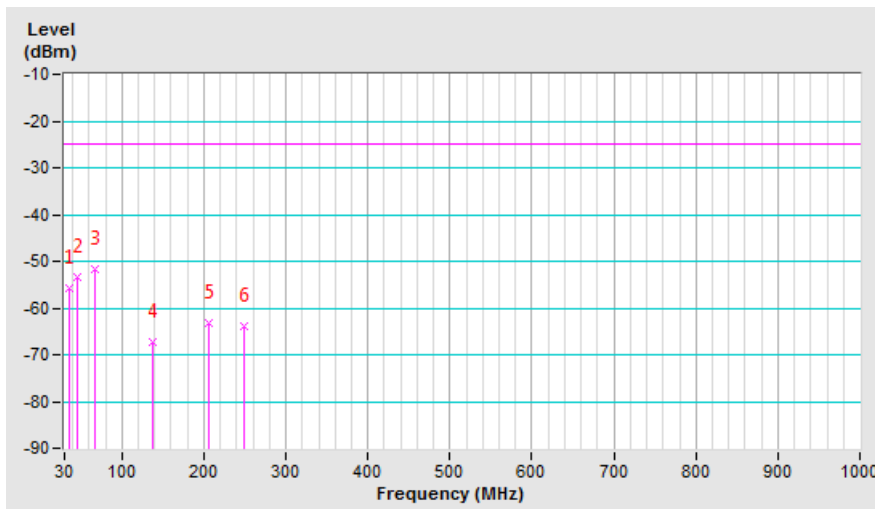

Above 1GHz
WCDMA Band 4

Mode	TX channel 1312 (1712.4MHz)	Frequency Range	1GHz ~ 20GHz
Environmental Conditions	22deg. C, 68%RH	Input Power	120Vac, 60Hz
Tested By	Greg Lin		

Antenna Polarity & Test Distance: Horizontal at 3 M							
No.	Freq. (MHz)	Reading (dBm)	S.G Power Value (dBm)	Correction Factor (dB)	EIRP (dBm)	Limit (dBm)	Margin (dB)
1	3424.80	-61.3	-52.7	1.3	-51.4	-13.0	-38.4
Antenna Polarity & Test Distance: Vertical at 3 M							
No.	Freq. (MHz)	Reading (dBm)	S.G Power Value (dBm)	Correction Factor (dB)	EIRP (dBm)	Limit (dBm)	Margin (dB)
1	3424.80	-59.8	-51.7	1.3	-50.4	-13.0	-37.4

Remarks:

1. EIRP (dBm) = S.G Value (dBm) + Correction Factor (dB).
2. Correction Factor (dB) = Substitution Antenna Gain (dB) + Cable Loss (dB).

Mode	TX channel 1413 (1732.6MHz)	Frequency Range	1GHz ~ 20GHz
Environmental Conditions	22deg. C, 68%RH	Input Power	120Vac, 60Hz
Tested By	Greg Lin		

Antenna Polarity & Test Distance: Horizontal at 3 M							
No.	Freq. (MHz)	Reading (dBm)	S.G Power Value (dBm)	Correction Factor (dB)	EIRP (dBm)	Limit (dBm)	Margin (dB)
1	3465.20	-61.2	-52.8	1.4	-51.4	-13.0	-38.4
Antenna Polarity & Test Distance: Vertical at 3 M							
No.	Freq. (MHz)	Reading (dBm)	S.G Power Value (dBm)	Correction Factor (dB)	EIRP (dBm)	Limit (dBm)	Margin (dB)
1	3465.20	-59.6	-51.8	1.4	-50.4	-13.0	-37.4

Remarks:

1. EIRP (dBm) = S.G Value (dBm) + Correction Factor (dB).
2. Correction Factor (dB) = Substitution Antenna Gain (dB) + Cable Loss (dB).

Mode	TX channel 1513 (1752.6MHz)	Frequency Range	1GHz ~ 20GHz
Environmental Conditions	22deg. C, 68%RH	Input Power	120Vac, 60Hz
Tested By	Greg Lin		

Antenna Polarity & Test Distance: Horizontal at 3 M							
No.	Freq. (MHz)	Reading (dBm)	S.G Power Value (dBm)	Correction Factor (dB)	EIRP (dBm)	Limit (dBm)	Margin (dB)
1	3505.20	-61.5	-53.3	1.5	-51.8	-13.0	-38.8
Antenna Polarity & Test Distance: Vertical at 3 M							
No.	Freq. (MHz)	Reading (dBm)	S.G Power Value (dBm)	Correction Factor (dB)	EIRP (dBm)	Limit (dBm)	Margin (dB)
1	3505.20	-59.9	-52.3	1.5	-50.8	-13.0	-37.8

Remarks:

1. EIRP (dBm) = S.G Value (dBm) + Correction Factor (dB).
2. Correction Factor (dB) = Substitution Antenna Gain (dB) + Cable Loss (dB).

LTE Band 4, Channel Bandwidth: 1.4MHz

Mode	TX channel 19957 (1710.7MHz)	Frequency Range	1GHz ~ 20GHz
Environmental Conditions	22deg. C, 68%RH	Input Power	120Vac, 60Hz
Tested By	Greg Lin		

Antenna Polarity & Test Distance: Horizontal at 3 M

No.	Freq. (MHz)	Reading (dBm)	S.G Power Value (dBm)	Correction Factor (dB)	EIRP (dBm)	Limit (dBm)	Margin (dB)
1	3421.40	-59.7	-51.1	1.3	-49.8	-13.0	-36.8

Antenna Polarity & Test Distance: Vertical at 3 M

No.	Freq. (MHz)	Reading (dBm)	S.G Power Value (dBm)	Correction Factor (dB)	EIRP (dBm)	Limit (dBm)	Margin (dB)
1	3421.40	-57.0	-48.9	1.3	-47.6	-13.0	-34.6

Remarks:

1. EIRP (dBm) = S.G Value (dBm) + Correction Factor (dB).
2. Correction Factor (dB) = Substitution Antenna Gain (dB) + Cable Loss (dB).

Mode	TX channel 20175 (1732.5MHz)	Frequency Range	1GHz ~ 20GHz
Environmental Conditions	22deg. C, 68%RH	Input Power	120Vac, 60Hz
Tested By	Greg Lin		

Antenna Polarity & Test Distance: Horizontal at 3 M

No.	Freq. (MHz)	Reading (dBm)	S.G Power Value (dBm)	Correction Factor (dB)	EIRP (dBm)	Limit (dBm)	Margin (dB)
1	3465.00	-59.6	-51.2	1.4	-49.8	-13.0	-36.8

Antenna Polarity & Test Distance: Vertical at 3 M

No.	Freq. (MHz)	Reading (dBm)	S.G Power Value (dBm)	Correction Factor (dB)	EIRP (dBm)	Limit (dBm)	Margin (dB)
1	3465.00	-56.8	-49.0	1.4	-47.6	-13.0	-34.6

Remarks:

1. EIRP (dBm) = S.G Value (dBm) + Correction Factor (dB).
2. Correction Factor (dB) = Substitution Antenna Gain (dB) + Cable Loss (dB).

Mode	TX channel 20393 (1754.3MHz)	Frequency Range	1GHz ~ 20GHz
Environmental Conditions	22deg. C, 68%RH	Input Power	120Vac, 60Hz
Tested By	Greg Lin		

Antenna Polarity & Test Distance: Horizontal at 3 M							
No.	Freq. (MHz)	Reading (dBm)	S.G Power Value (dBm)	Correction Factor (dB)	EIRP (dBm)	Limit (dBm)	Margin (dB)
1	3508.60	-59.4	-51.1	1.4	-49.7	-13.0	-36.7
Antenna Polarity & Test Distance: Vertical at 3 M							
No.	Freq. (MHz)	Reading (dBm)	S.G Power Value (dBm)	Correction Factor (dB)	EIRP (dBm)	Limit (dBm)	Margin (dB)
1	3508.60	-57.3	-49.6	1.4	-48.2	-13.0	-35.2

Remarks:

1. EIRP (dBm) = S.G Value (dBm) + Correction Factor (dB).
2. Correction Factor (dB) = Substitution Antenna Gain (dB) + Cable Loss (dB).

LTE Band 4, Channel Bandwidth: 5MHz

Mode	TX channel 19975 (1712.5MHz)	Frequency Range	1GHz ~ 20GHz
Environmental Conditions	22deg. C, 68%RH	Input Power	120Vac, 60Hz
Tested By	Greg Lin		

Antenna Polarity & Test Distance: Horizontal at 3 M

No.	Freq. (MHz)	Reading (dBm)	S.G Power Value (dBm)	Correction Factor (dB)	EIRP (dBm)	Limit (dBm)	Margin (dB)
1	3425.00	-59.8	-51.2	1.3	-49.9	-13.0	-36.9

Antenna Polarity & Test Distance: Vertical at 3 M

No.	Freq. (MHz)	Reading (dBm)	S.G Power Value (dBm)	Correction Factor (dB)	EIRP (dBm)	Limit (dBm)	Margin (dB)
1	3425.00	-57.0	-48.9	1.3	-47.6	-13.0	-34.6

Remarks:

1. EIRP (dBm) = S.G Value (dBm) + Correction Factor (dB).
2. Correction Factor (dB) = Substitution Antenna Gain (dB) + Cable Loss (dB).

Mode	TX channel 20175 (1732.5MHz)	Frequency Range	1GHz ~ 20GHz
Environmental Conditions	22deg. C, 68%RH	Input Power	120Vac, 60Hz
Tested By	Greg Lin		

Antenna Polarity & Test Distance: Horizontal at 3 M

No.	Freq. (MHz)	Reading (dBm)	S.G Power Value (dBm)	Correction Factor (dB)	EIRP (dBm)	Limit (dBm)	Margin (dB)
1	3465.00	-59.7	-51.3	1.4	-49.9	-13.0	-36.9

Antenna Polarity & Test Distance: Vertical at 3 M

No.	Freq. (MHz)	Reading (dBm)	S.G Power Value (dBm)	Correction Factor (dB)	EIRP (dBm)	Limit (dBm)	Margin (dB)
1	3465.00	-57.6	-49.8	1.4	-48.4	-13.0	-35.4

Remarks:

1. EIRP (dBm) = S.G Value (dBm) + Correction Factor (dB).
2. Correction Factor (dB) = Substitution Antenna Gain (dB) + Cable Loss (dB).

Mode	TX channel 20375 (1752.5MHz)	Frequency Range	1GHz ~ 20GHz
Environmental Conditions	22deg. C, 68%RH	Input Power	120Vac, 60Hz
Tested By	Greg Lin		

Antenna Polarity & Test Distance: Horizontal at 3 M							
No.	Freq. (MHz)	Reading (dBm)	S.G Power Value (dBm)	Correction Factor (dB)	EIRP (dBm)	Limit (dBm)	Margin (dB)
1	3505.00	-59.6	-51.4	1.5	-49.9	-13.0	-36.9
Antenna Polarity & Test Distance: Vertical at 3 M							
No.	Freq. (MHz)	Reading (dBm)	S.G Power Value (dBm)	Correction Factor (dB)	EIRP (dBm)	Limit (dBm)	Margin (dB)
1	3505.00	-57.4	-49.8	1.5	-48.3	-13.0	-35.3

Remarks:

1. EIRP (dBm) = S.G Value (dBm) + Correction Factor (dB).
2. Correction Factor (dB) = Substitution Antenna Gain (dB) + Cable Loss (dB).

LTE Band 4, Channel Bandwidth: 20MHz

Mode	TX channel 20050 (1720.0MHz)	Frequency Range	1GHz ~ 20GHz
Environmental Conditions	22deg. C, 68%RH	Input Power	120Vac, 60Hz
Tested By	Greg Lin		

Antenna Polarity & Test Distance: Horizontal at 3 M

No.	Freq. (MHz)	Reading (dBm)	S.G Power Value (dBm)	Correction Factor (dB)	EIRP (dBm)	Limit (dBm)	Margin (dB)
1	3440.00	-59.6	-51.1	1.3	-49.8	-13.0	-36.8

Antenna Polarity & Test Distance: Vertical at 3 M

No.	Freq. (MHz)	Reading (dBm)	S.G Power Value (dBm)	Correction Factor (dB)	EIRP (dBm)	Limit (dBm)	Margin (dB)
1	3440.00	-57.6	-49.6	1.3	-48.3	-13.0	-35.3

Remarks:

1. EIRP (dBm) = S.G Value (dBm) + Correction Factor (dB).
2. Correction Factor (dB) = Substitution Antenna Gain (dB) + Cable Loss (dB).

Mode	TX channel 20175 (1732.5MHz)	Frequency Range	1GHz ~ 20GHz
Environmental Conditions	22deg. C, 68%RH	Input Power	120Vac, 60Hz
Tested By	Greg Lin		

Antenna Polarity & Test Distance: Horizontal at 3 M

No.	Freq. (MHz)	Reading (dBm)	S.G Power Value (dBm)	Correction Factor (dB)	EIRP (dBm)	Limit (dBm)	Margin (dB)
1	3465.00	-59.5	-51.1	1.4	-49.7	-13.0	-36.7

Antenna Polarity & Test Distance: Vertical at 3 M

No.	Freq. (MHz)	Reading (dBm)	S.G Power Value (dBm)	Correction Factor (dB)	EIRP (dBm)	Limit (dBm)	Margin (dB)
1	3465.00	-57.4	-49.6	1.4	-48.2	-13.0	-35.2

Remarks:

1. EIRP (dBm) = S.G Value (dBm) + Correction Factor (dB).
2. Correction Factor (dB) = Substitution Antenna Gain (dB) + Cable Loss (dB).

Mode	TX channel 20300 (1745.0MHz)	Frequency Range	1GHz ~ 20GHz
Environmental Conditions	22deg. C, 68%RH	Input Power	120Vac, 60Hz
Tested By	Greg Lin		

Antenna Polarity & Test Distance: Horizontal at 3 M							
No.	Freq. (MHz)	Reading (dBm)	S.G Power Value (dBm)	Correction Factor (dB)	EIRP (dBm)	Limit (dBm)	Margin (dB)
1	3490.00	-59.3	-51.1	1.5	-49.6	-13.0	-36.6
Antenna Polarity & Test Distance: Vertical at 3 M							
No.	Freq. (MHz)	Reading (dBm)	S.G Power Value (dBm)	Correction Factor (dB)	EIRP (dBm)	Limit (dBm)	Margin (dB)
1	3490.00	-56.8	-49.2	1.5	-47.7	-13.0	-34.7

Remarks:

1. EIRP (dBm) = S.G Value (dBm) + Correction Factor (dB).
2. Correction Factor (dB) = Substitution Antenna Gain (dB) + Cable Loss (dB).

LTE Band 7, Channel Bandwidth: 5MHz

Mode	TX channel 20775 (2502.5MHz)	Frequency Range	1GHz ~ 27GHz
Environmental Conditions	22deg. C, 68%RH	Input Power	120Vac, 60Hz
Tested By	Greg Lin		

Antenna Polarity & Test Distance: Horizontal at 3 M

No.	Freq. (MHz)	Reading (dBm)	S.G Power Value (dBm)	Correction Factor (dB)	EIRP (dBm)	Limit (dBm)	Margin (dB)
1	5005.00	-60.2	-47.9	1.4	-46.5	-25.0	-21.5

Antenna Polarity & Test Distance: Vertical at 3 M

No.	Freq. (MHz)	Reading (dBm)	S.G Power Value (dBm)	Correction Factor (dB)	EIRP (dBm)	Limit (dBm)	Margin (dB)
1	5005.00	-57.7	-46.7	1.4	-45.3	-25.0	-20.3

Remarks:

1. EIRP (dBm) = S.G Value (dBm) + Correction Factor (dB).
2. Correction Factor (dB) = Substitution Antenna Gain (dB) + Cable Loss (dB).

Mode	TX channel 21100 (2535MHz)	Frequency Range	1GHz ~ 27GHz
Environmental Conditions	22deg. C, 68%RH	Input Power	120Vac, 60Hz
Tested By	Greg Lin		

Antenna Polarity & Test Distance: Horizontal at 3 M

No.	Freq. (MHz)	Reading (dBm)	S.G Power Value (dBm)	Correction Factor (dB)	EIRP (dBm)	Limit (dBm)	Margin (dB)
1	5070.00	-59.4	-46.9	1.4	-45.5	-25.0	-20.5

Antenna Polarity & Test Distance: Vertical at 3 M

No.	Freq. (MHz)	Reading (dBm)	S.G Power Value (dBm)	Correction Factor (dB)	EIRP (dBm)	Limit (dBm)	Margin (dB)
1	5070.00	-58.0	-46.6	1.4	-45.2	-25.0	-20.2

Remarks:

1. EIRP (dBm) = S.G Value (dBm) + Correction Factor (dB).
2. Correction Factor (dB) = Substitution Antenna Gain (dB) + Cable Loss (dB).

Mode	TX channel 21425 (2567.5MHz)	Frequency Range	1GHz ~ 27GHz
Environmental Conditions	22deg. C, 68%RH	Input Power	120Vac, 60Hz
Tested By	Greg Lin		

Antenna Polarity & Test Distance: Horizontal at 3 M							
No.	Freq. (MHz)	Reading (dBm)	S.G Power Value (dBm)	Correction Factor (dB)	EIRP (dBm)	Limit (dBm)	Margin (dB)
1	5135.00	-59.8	-47.6	1.4	-46.2	-25.0	-21.2
Antenna Polarity & Test Distance: Vertical at 3 M							
No.	Freq. (MHz)	Reading (dBm)	S.G Power Value (dBm)	Correction Factor (dB)	EIRP (dBm)	Limit (dBm)	Margin (dB)
1	5135.00	-57.1	-45.3	1.4	-43.9	-25.0	-18.9

Remarks:

1. EIRP (dBm) = S.G Value (dBm) + Correction Factor (dB).
2. Correction Factor (dB) = Substitution Antenna Gain (dB) + Cable Loss (dB).

LTE Band 7, Channel Bandwidth: 20MHz

Mode	TX channel 20850 (2510MHz)	Frequency Range	1GHz ~ 27GHz
Environmental Conditions	22deg. C, 68%RH	Input Power	120Vac, 60Hz
Tested By	Greg Lin		

Antenna Polarity & Test Distance: Horizontal at 3 M

No.	Freq. (MHz)	Reading (dBm)	S.G Power Value (dBm)	Correction Factor (dB)	EIRP (dBm)	Limit (dBm)	Margin (dB)
1	5020.00	-59.2	-46.8	1.4	-45.4	-25.0	-20.4

Antenna Polarity & Test Distance: Vertical at 3 M

No.	Freq. (MHz)	Reading (dBm)	S.G Power Value (dBm)	Correction Factor (dB)	EIRP (dBm)	Limit (dBm)	Margin (dB)
1	5020.00	-57.0	-45.9	1.4	-44.5	-25.0	-19.5

Remarks:

1. EIRP (dBm) = S.G Value (dBm) + Correction Factor (dB).
2. Correction Factor (dB) = Substitution Antenna Gain (dB) + Cable Loss (dB).

Mode	TX channel 21100 (2535MHz)	Frequency Range	1GHz ~ 27GHz
Environmental Conditions	22deg. C, 68%RH	Input Power	120Vac, 60Hz
Tested By	Greg Lin		

Antenna Polarity & Test Distance: Horizontal at 3 M

No.	Freq. (MHz)	Reading (dBm)	S.G Power Value (dBm)	Correction Factor (dB)	EIRP (dBm)	Limit (dBm)	Margin (dB)
1	5070.00	-59.6	-47.1	1.4	-45.7	-25.0	-20.7

Antenna Polarity & Test Distance: Vertical at 3 M

No.	Freq. (MHz)	Reading (dBm)	S.G Power Value (dBm)	Correction Factor (dB)	EIRP (dBm)	Limit (dBm)	Margin (dB)
1	5070.00	-57.2	-45.8	1.4	-44.4	-25.0	-19.4

Remarks:

1. EIRP (dBm) = S.G Value (dBm) + Correction Factor (dB).
2. Correction Factor (dB) = Substitution Antenna Gain (dB) + Cable Loss (dB).

Mode	TX channel 21350 (2560MHz)	Frequency Range	1GHz ~ 27GHz
Environmental Conditions	22deg. C, 68%RH	Input Power	120Vac, 60Hz
Tested By	Greg Lin		

Antenna Polarity & Test Distance: Horizontal at 3 M							
No.	Freq. (MHz)	Reading (dBm)	S.G Power Value (dBm)	Correction Factor (dB)	EIRP (dBm)	Limit (dBm)	Margin (dB)
1	5120.00	-60.1	-47.8	1.4	-46.4	-25.0	-21.4
Antenna Polarity & Test Distance: Vertical at 3 M							
No.	Freq. (MHz)	Reading (dBm)	S.G Power Value (dBm)	Correction Factor (dB)	EIRP (dBm)	Limit (dBm)	Margin (dB)
1	5120.00	-57.6	-45.8	1.4	-44.4	-25.0	-19.4

Remarks:

1. EIRP (dBm) = S.G Value (dBm) + Correction Factor (dB).
2. Correction Factor (dB) = Substitution Antenna Gain (dB) + Cable Loss (dB).

5 Pictures of Test Arrangements

Please refer to the attached file (Test Setup Photo).

Appendix – Information of the Testing Laboratories

We, Bureau Veritas Consumer Products Services (H.K.) Ltd., Taoyuan Branch, were founded in 1988 to provide our best service in EMC, Radio, Telecom and Safety consultation. Our laboratories are FCC recognized accredited test firms and accredited and approved according to ISO/IEC 17025.

If you have any comments, please feel free to contact us at the following:

Lin Kou EMC/RF Lab

Tel: 886-2-26052180

Fax: 886-2-26051924

Hsin Chu EMC/RF/Telecom Lab

Tel: 886-3-6668565

Fax: 886-3-6668323

Hwa Ya EMC/RF/Safety Lab

Tel: 886-3-3183232

Fax: 886-3-3270892

Email: service.adt@tw.bureauveritas.com

Web Site: www.bureauveritas-adt.com

The address and road map of all our labs can be found in our web site also.

--- END ---