



# FCC RADIO TEST REPORT

**FCC ID** : LHJ-BL28NARD1  
**Equipment** : BL28NA-RD1  
**Brand Name** : Continental  
**Model Name** : BL28NA-RD1  
**Applicant** : Continental Automotive Systems, Inc.  
 21440 West Lake Cook Road, Deer Park, Illinois 60010, United States  
**Manufacturer** : Continental Automotive Systems, Inc.  
 21440 West Lake Cook Road, Deer Park, Illinois 60010, United States  
**Standard** : FCC 47 CFR Part 2, 22(H), 24(E), 27

The product was received on Oct. 07, 2021 and testing was started from Oct. 12, 2021 and completed on Oct. 15, 2021. We, Sporton International Inc. EMC & Wireless Communications Laboratory, would like to declare that the tested sample has been evaluated in accordance with the test procedures given in ANSI / TIA-603-E and has been in compliance with the applicable technical standards.

The test results in this variant report apply exclusively to the tested model / sample. Without written approval of Sporton International Inc. EMC & Wireless Communications Laboratory, the test report shall not be reproduced except in full.

*Louis Wu*

Approved by: Louis Wu

**Sporton International Inc. EMC & Wireless Communications Laboratory**

No. 52, Huaya 1st Rd., Guishan Dist., Taoyuan City 333, Taiwan (R.O.C.)



## Table of Contents

History of this test report.....	3
Summary of Test Result.....	4
<b>1 General Description .....</b>	<b>6</b>
1.1 Product Feature of Equipment Under Test.....	6
1.2 Product Specification of Equipment Under Test.....	6
1.3 Modification of EUT .....	6
1.4 Testing Location .....	7
1.5 Applicable Standards.....	7
<b>2 Test Configuration of Equipment Under Test .....</b>	<b>8</b>
2.1 Test Mode.....	8
2.2 Connection Diagram of Test System.....	10
2.3 Support Unit used in test configuration and system .....	10
2.4 Measurement Results Explanation Example.....	10
2.5 Frequency List of Low/Middle/High Channels .....	11
<b>3 Conducted Test Items.....</b>	<b>13</b>
3.1 Measuring Instruments .....	13
3.2 Conducted Output Power and ERP/EIRP .....	14
3.3 Peak-to-Average Ratio .....	15
3.4 Occupied Bandwidth.....	16
3.5 Conducted Band Edge .....	17
3.6 Frequency Stability .....	19
<b>4 Radiated Test Items .....</b>	<b>20</b>
4.1 Measuring Instruments .....	20
4.2 Radiated Spurious Emission Measurement .....	22
<b>5 List of Measuring Equipment.....</b>	<b>23</b>
<b>6 Uncertainty of Evaluation.....</b>	<b>25</b>
<b>Appendix A. Test Results of Conducted Test</b>	
<b>Appendix B. Test Results of Radiated Test</b>	
<b>Appendix C. Test Setup Photographs</b>	





### Summary of Test Result

Report Clause	Ref Std. Clause	Test Items	Result (PASS/FAIL)	Remark
3.2	§2.1046	Conducted Output Power	Reporting only	-
	§22.913 (a)(5)	Effective Radiated Power (Band 5)	Pass	
	§27.50 (c)(10)	Effective Radiated Power (Band 12) (Band 13)		
	§24.232 (c) §27.50 (h)(2)	Equivalent Isotropic Radiated Power (Band 2) (Band 7)		
	§27.50 (d)(4)	Equivalent Isotropic Radiated Power (Band 4)		
3.3	§24.232 (d) §27.50 (d)(5)	Peak-to-Average Ratio	Pass	-
3.4	§2.1049	Occupied Bandwidth	Reporting only	-
3.5	§2.1051 §22.917 (a) §24.238 (a) §27.53 (g) §27.53 (h)	Conducted Band Edge Measurement (Band 2) (Band 4) (Band 5) (Band 12) (Band 13)	Pass	-
	§2.1051 §27.53 (m)(4)	Conducted Band Edge Measurement (Band 7)		
-	§2.1051 §22.917 (a) §24.238 (a) §27.53 (g) §27.53 (h)	Conducted Spurious Emission (Band 2) (Band 4) (Band 5) (Band 12) (Band 13)	Not Required	-
	§2.1051 §27.53 (m)(4)	Conducted Spurious Emission (Band 7)		
3.6	§2.1055 §22.355 §24.235 §27.54	Frequency Stability Temperature & Voltage	Pass	-



Report Clause	Ref Std. Clause	Test Items	Result (PASS/FAIL)	Remark
4.2	§2.1053 §22.917 (a) §24.238 (a) §27.53 (g) §27.53 (h)	Radiated Spurious Emission (Band 2) (Band 4) (Band 5) (Band 12) (Band 13)	Pass	Under limit 17.51 dB at 5019.000 MHz
	§2.1051 §27.53 (m)(4)	Radiated Spurious Emission (Band 7)		

**Remark:**

1. Not required means after assessing, test items are not necessary to carry out.
2. This is a variant report by adding 16QAM modulation. All the test cases were performed on original report which can be referred to Sporton Report Number FG120221-01.

<b>Declaration of Conformity:</b>
The test results with all measurement uncertainty excluded are presented in accordance with the regulation limits or requirements declared by manufacturers.
<b>Comments and Explanations:</b>
The declared of product specification for EUT presented in the report are provided by the manufacturer, and the manufacturer takes all the responsibilities for the accuracy of product specification.

**Reviewed by: Yun Huang**

**Report Producer: Tina Chuang**



# 1 General Description

## 1.1 Product Feature of Equipment Under Test

Product Feature	
Equipment	BL28NA-RD1
Brand Name	Continental
Model Name	BL28NA-RD1
FCC ID	LHJ-BL28NARD1
EUT supports Radios application	GPRS/EGPRS/WCDMA/HSPA/LTE/GNSS
EUT Stage	Identical Prototype

Remark: The above EUT's information was declared by manufacturer.

## 1.2 Product Specification of Equipment Under Test

Product Specification is subject to this standard	
Tx Frequency	LTE Band 2: 1850.7 MHz ~ 1909.3 MHz LTE Band 4: 1710.7 MHz ~ 1754.3 MHz LTE Band 5: 824.7 MHz ~ 848.3 MHz LTE Band 7: 2502.5 MHz ~ 2567.5 MHz LTE Band 12: 699.7 MHz ~ 715.3 MHz LTE Band 13: 779.5 MHz ~ 784.5 MHz
Rx Frequency	LTE Band 2: 1930.7 MHz ~ 1989.3 MHz LTE Band 4: 2110.7 MHz ~ 2154.3 MHz LTE Band 5: 869.7 MHz ~ 893.3 MHz LTE Band 7: 2622.5MHz ~ 2687.5 MHz LTE Band 12: 729.7 MHz ~ 745.3 MHz LTE Band 13: 748.5 MHz ~ 753.5 MHz
Bandwidth	LTE Band 2: 1.4MHz / 3MHz / 5MHz / 10MHz / 15MHz / 20MHz LTE Band 4: 1.4MHz / 3MHz / 5MHz / 10MHz / 15MHz / 20MHz LTE Band 5: 1.4MHz / 3MHz / 5MHz / 10MHz LTE Band 7: 5MHz / 10MHz / 15MHz / 20MHz LTE Band 12: 1.4MHz / 3MHz / 5MHz / 10MHz LTE Band 13: 5MHz / 10MHz
Maximum Output Power to Antenna	LTE Band 2 : 21.58 dBm LTE Band 4 : 21.93 dBm LTE Band 5 : 21.81 dBm LTE Band 7 : 21.61 dBm LTE Band 12 : 22.82 dBm
Antenna Type	Fixed External Antenna Antenna Model name: SPDA24700/2700 Antenna Manufactory: Pulse electronics
Type of Modulation	QPSK / 16QAM

Remark: The above EUT's information was declared by manufacturer. Please refer to Comments and Explanations in report summary.

## 1.3 Modification of EUT

No modifications are made to the EUT during all test items.



### 1.4 Testing Location

<b>Test Site</b>	Sporton International Inc. EMC & Wireless Communications Laboratory
<b>Test Site Location</b>	No.52, Huaya 1st Rd., Guishan Dist., Taoyuan City 333, Taiwan (R.O.C.) TEL: +886-3-327-3456 FAX: +886-3-328-4978
<b>Test Site No.</b>	<b>Sporton Site No.</b>
	TH03-HY
<b>Test Engineer</b>	HaoEn Zhang
<b>Temperature</b>	22.3~24.5 °C
<b>Relative Humidity</b>	52.3~54.1 %

<b>Test Site</b>	Sporton International Inc. Wensan Laboratory
<b>Test Site Location</b>	No.58, Aly. 75, Ln. 564, Wenhua 3rd, Rd., Guishan Dist., Taoyuan City 333010, Taiwan (R.O.C.) TEL: +886-3-327-0868 FAX: +886-3-327-0855
<b>Test Site No.</b>	<b>Sporton Site No.</b>
	03CH13-HY (TAF Code: 3786)
<b>Test Engineer</b>	Yuan Lee and Jacky Hung
<b>Temperature</b>	20~25°C
<b>Relative Humidity</b>	50~60%
<b>Remark</b>	The Radiated Spurious Emission test item subcontracted to Sporton International Inc. Wensan Laboratory.

**Note:** The test site complies with ANSI C63.4 2014 requirement.

FCC Designation No.: TW1190 and TW3786

### 1.5 Applicable Standards

According to the specifications of the manufacturer, the EUT must comply with the requirements of the following standards:

- ♦ ANSI C63.26-2015
- ♦ ANSI / TIA-603-E
- ♦ FCC 47 CFR Part 2, 22(H), 24(E), 27
- ♦ FCC KDB 971168 D01 Power Meas. License Digital Systems v03r01
- ♦ FCC KDB 412172 D01 Determining ERP and EIRP v01r01
- ♦ FCC KDB 414788 D01 Radiated Test Site v01r01.

**Remark:**

1. All test items were verified and recorded according to the standards and without any deviation during the test.
2. The TAF code is not including all the FCC KDB listed without accreditation.



## 2 Test Configuration of Equipment Under Test

### 2.1 Test Mode

Antenna port conducted and radiated test items listed below are performed according to KDB 971168 D01 Power Meas. License Digital Systems v03r01 with maximum output power.

The measured emission level of the EUT was maximized by rotating the EUT on a turntable, adjusting the orientation of the EUT and EUT antenna in two angles of antenna (Horizontal angle and Vertical angle), and adjusting the measurement antenna orientation, following C63.26 exploratory test procedures and find (Ant. Horizontal for LTE Band 2, 5, 12 ; Ant. Vertical for LTE Band 4, 7) as worst plane.

Test Items	Band	Bandwidth (MHz)						Modulation		RB #			Test Channel		
		1.4	3	5	10	15	20	QPSK	16QAM	1	Half	Full	L	M	H
Max. Output Power	2	v	v	v	v	v	v		v	v	v	v	v	v	v
	4	v	v	v	v	v	v		v	v	v	v	v	v	v
	5	v	v	v	v	-	-		v	v	v	v	v	v	v
	7	-	-	v	v	v	v		v	v	v	v	v	v	v
	12	v	v	v	v	-	-		v	v	v	v	v	v	v
Peak-to-Average Ratio	2						v		v			v		v	
	4						v		v			v		v	
	5				v	-	-		v			v		v	
	7	-	-				v		v			v		v	
	12				v	-	-		v			v		v	
26dB and 99% Bandwidth	2	v	v	v	v	v	v		v			v		v	
	4	v	v	v	v	v	v		v			v		v	
	5	v	v	v	v	-	-		v			v		v	
	7	-	-	v	v	v	v		v			v		v	
	12	v	v	v	v	-	-		v			v		v	
Conducted Band Edge	2	v	v	v	v	v	v		v	v		v	v		v
	4	v	v	v	v	v	v		v	v		v	v		v
	5	v	v	v	v	-	-		v	v		v	v		v
	7	-	-	v	v	v	v		v	v		v	v		v
	12	v	v	v	v	-	-		v	v		v	v		v





Test Items	Band	Bandwidth (MHz)						Modulation		RB #			Test Channel		
		1.4	3	5	10	15	20	QPSK	16QAM	1	Half	Full	L	M	H
Frequency Stability	2				v				v			v		v	
	4				v				v			v		v	
	5				v	-	-		v			v		v	
	7	-	-		v				v			v		v	
	12				v	-	-		v			v		v	
E.R.P / E.I.R.P	2	v	v	v	v	v	v		v	Max. Power					
	4	v	v	v	v	v	v		v	Max. Power					
	5	v	v	v	v	-	-		v	Max. Power					
	7	-	-	v	v	v	v		v	Max. Power					
	12	v	v	v	v	-	-		v	Max. Power					
Radiated Spurious Emission	2	Worst Case										v	v	v	
	4	Worst Case										v	v	v	
	5	Worst Case										v	v	v	
	7	Worst Case										v	v	v	
	12	Worst Case										v	v	v	
Remark	1. The mark "v " means that this configuration is chosen for testing 2. The mark "- " means that this bandwidth is not supported. 3. The device is investigated from 30MHz to 10 times of fundamental signal for radiated spurious emission test under different RB size/offset and modulations in exploratory test. Subsequently, only the worst case emissions are reported.														

## 2.2 Connection Diagram of Test System

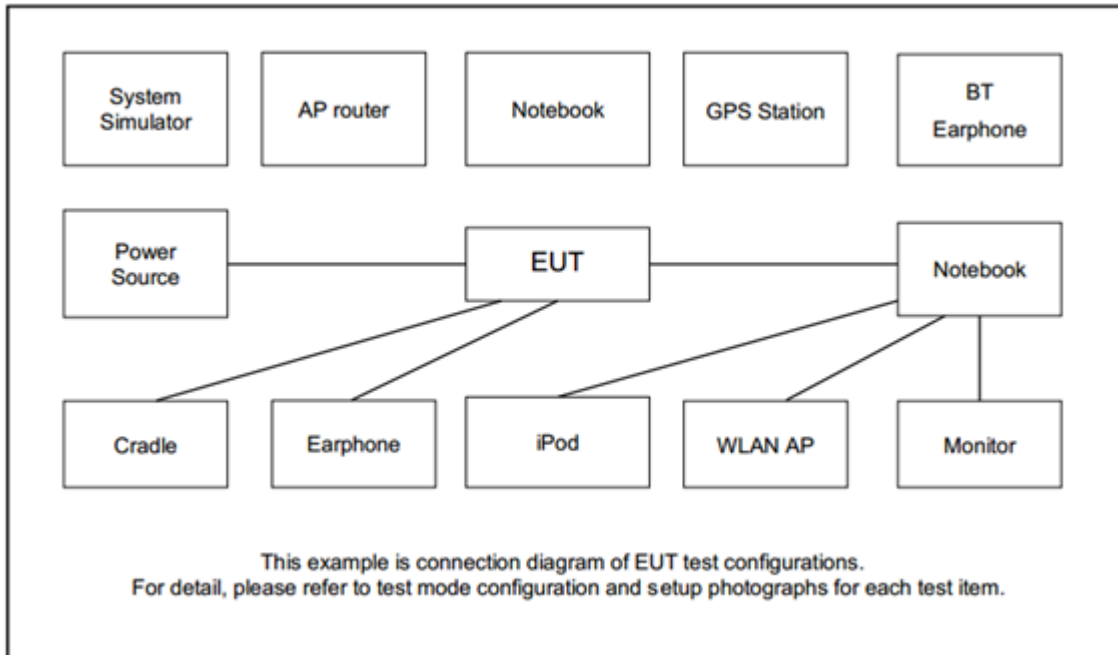

## 2.3 Support Unit used in test configuration and system

Item	Equipment	Brand Name	Model No.	FCC ID	Data Cable	Power Cord
1.	System Simulator	Anritsu	MT8821C	N/A	N/A	Unshielded, 1.8 m
2.	Dipole Antenna	Larsen	SPDA24700/2700	N/A	N/A	N/A
3.	Adapter	Qualtek	ATS018T-W120U	N/A	N/A	N/A

## 2.4 Measurement Results Explanation Example

### For all conducted test items:

The offset level is set in the spectrum analyzer to compensate the RF cable loss and attenuator factor between EUT conducted output port and spectrum analyzer. With the offset compensation, the spectrum analyzer reading level is exactly the EUT RF output level.

The spectrum analyzer offset is derived from RF cable loss and attenuator factor.

*Offset = RF cable loss + attenuator factor.*

Following shows an offset computation example with cable loss 4.2 dB and 10dB attenuator.

Example :

$$\begin{aligned} \text{Offset(dB)} &= \text{RF cable loss(dB)} + \text{attenuator factor(dB)} \\ &= 4.2 + 10 = 14.2 \text{ (dB)} \end{aligned}$$



### 2.5 Frequency List of Low/Middle/High Channels

LTE Band 2 Channel and Frequency List				
BW [MHz]	Channel/Frequency(MHz)	Lowest	Middle	Highest
20	Channel	18700	18900	19100
	Frequency	1860	1880	1900
15	Channel	18675	18900	19125
	Frequency	1857.5	1880	1902.5
10	Channel	18650	18900	19150
	Frequency	1855	1880	1905
5	Channel	18625	18900	19175
	Frequency	1852.5	1880	1907.5
3	Channel	18615	18900	19185
	Frequency	1851.5	1880	1908.5
1.4	Channel	18607	18900	19193
	Frequency	1850.7	1880	1909.3

LTE Band 4 Channel and Frequency List				
BW [MHz]	Channel/Frequency(MHz)	Lowest	Middle	Highest
20	Channel	20050	20175	20300
	Frequency	1720	1732.5	1745
15	Channel	20025	20175	20325
	Frequency	1717.5	1732.5	1747.5
10	Channel	20000	20175	20350
	Frequency	1715	1732.5	1750
5	Channel	19975	20175	20375
	Frequency	1712.5	1732.5	1752.5
3	Channel	19965	20175	20385
	Frequency	1711.5	1732.5	1753.5
1.4	Channel	19957	20175	20393
	Frequency	1710.7	1732.5	1754.3



LTE Band 5 Channel and Frequency List				
BW [MHz]	Channel/Frequency(MHz)	Lowest	Middle	Highest
10	Channel	20450	20525	20600
	Frequency	829	836.5	844
5	Channel	20425	20525	20625
	Frequency	826.5	836.5	846.5
3	Channel	20415	20525	20635
	Frequency	825.5	836.5	847.5
1.4	Channel	20407	20525	20643
	Frequency	824.7	836.5	848.3

LTE Band 7 Channel and Frequency List				
BW [MHz]	Channel/Frequency(MHz)	Lowest	Middle	Highest
20	Channel	20850	21100	21350
	Frequency	2510	2535	2560
15	Channel	20825	21100	21375
	Frequency	2507.5	2535	2562.5
10	Channel	20800	21100	21400
	Frequency	2505	2535	2565
5	Channel	20775	21100	21425
	Frequency	2502.5	2535	2567.5

LTE Band 12 Channel and Frequency List				
BW [MHz]	Channel/Frequency(MHz)	Lowest	Middle	Highest
10	Channel	23060	23095	23130
	Frequency	704	707.5	711
5	Channel	23035	23095	23155
	Frequency	701.5	707.5	713.5
3	Channel	23025	23095	23165
	Frequency	700.5	707.5	714.5
1.4	Channel	23017	23095	23173
	Frequency	699.7	707.5	715.3

### 3 Conducted Test Items

#### 3.1 Measuring Instruments

See list of measuring instruments of this test report.

##### 3.1.1 Test Setup

##### 3.1.2 Conducted Output Power

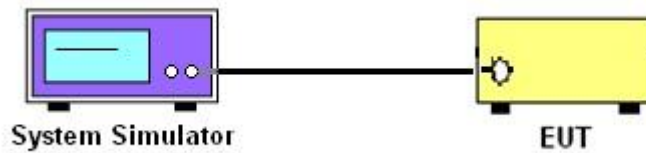

##### 3.1.3 Peak-to-Average Ratio, Occupied Bandwidth and Conducted Band-Edge

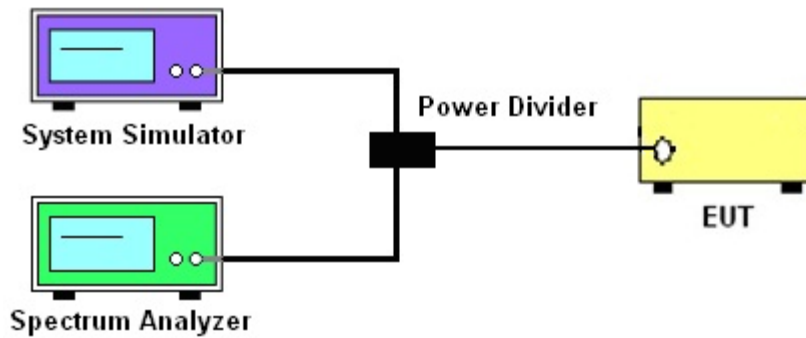

##### 3.1.4 Frequency Stability

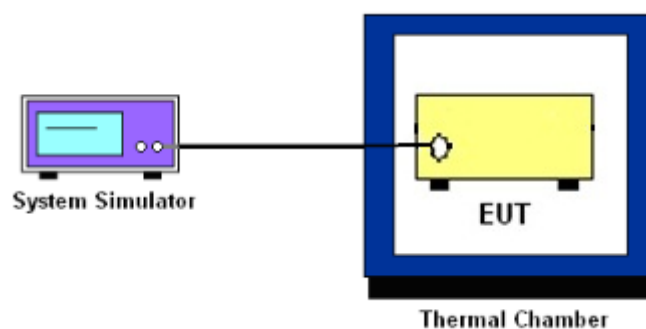

##### 3.1.5 Test Result of Conducted Test

Please refer to Appendix A.



## 3.2 Conducted Output Power and ERP/EIRP

### 3.2.1 Description of the Conducted Output Power Measurement and ERP/EIRP Measurement

A system simulator was used to establish communication with the EUT. Its parameters were set to force the EUT transmitting at maximum output power. The measured power in the radio frequency on the transmitter output terminals shall be reported.

The ERP of mobile transmitters must not exceed 7 Watts for LTE Band 5

The ERP of mobile transmitters must not exceed 3 Watts for LTE Band 12

The EIRP of mobile transmitters must not exceed 2 Watts for LTE Band 2 and Band 7

The EIRP of mobile transmitters must not exceed 1 Watts for LTE Band 4

According to KDB 412172 D01 Power Approach,

$EIRP = P_T + G_T - L_C$ ,  $ERP = EIRP - 2.15$ , where

$P_T$  = transmitter output power in dBm

$G_T$  = gain of the transmitting antenna in dBi

$L_C$  = signal attenuation in the connecting cable between the transmitter and antenna in dB

### 3.2.2 Test Procedures

1. The transmitter output port was connected to the system simulator.
2. Set EUT at maximum power through the system simulator.
3. Select lowest, middle, and highest channels for each band and different modulation.
4. Measure and record the power level from the system simulator.



### **3.3 Peak-to-Average Ratio**

#### **3.3.1 Description of the PAR Measurement**

Power Complementary Cumulative Distribution Function (CCDF) curves provide a means for characterizing the power peaks of a digitally modulated signal on a statistical basis. A CCDF curve depicts the probability of the peak signal amplitude exceeding the average power level. Most contemporary measurement instrumentation include the capability to produce CCDF curves for an input signal provided that the instrument's resolution bandwidth can be set wide enough to accommodate the entire input signal bandwidth. In measuring transmissions in this band using an average power technique, the peak-to-average ratio (PAR) of the transmission may not exceed 13 dB.

#### **3.3.2 Test Procedures**

The testing follows ANSI C63.26-2015 Section 5.2.6

1. The EUT was connected to spectrum and system simulator via a power divider.
2. Set the CCDF (Complementary Cumulative Distribution Function) option in spectrum analyzer.
3. The highest RF powers were measured and recorded the maximum PAPR level associated with a probability of 0.1 %.
4. Record the deviation as Peak to Average Ratio.



## 3.4 Occupied Bandwidth

### 3.4.1 Description of Occupied Bandwidth Measurement

The occupied bandwidth is the width of a frequency band such that, below the lower and above the upper frequency limits, the mean powers emitted are each equal to a specified percentage 0.5% of the total mean transmitted power.

The 26 dB emission bandwidth is defined as the frequency range between two points, one above and one below the carrier frequency, at which the spectral density of the emission is attenuated 26 dB below the maximum in-band spectral density of the modulated signal. Spectral density (power per unit bandwidth) is to be measured with a detector of resolution bandwidth equal to approximately 1.0% of the emission bandwidth.

### 3.4.2 Test Procedures

The testing follows ANSI C63.26-2015 Section 5.4.3 (26dB) and Section 5.4.4 (99OB)

1. The EUT was connected to spectrum analyzer and system simulator via a power divider.
2. The spectrum analyzer center frequency is set to the nominal EUT channel center frequency. The span range for the spectrum analyzer shall be between two and five times the anticipated OBW.
3. The nominal resolution bandwidth (RBW) shall be in the range of 1 to 5 % of the anticipated OBW, and the VBW shall be at least 3 times the RBW.
4. Set the detection mode to peak, and the trace mode to max hold.
5. Determine the reference value: Set the EUT to transmit a modulated signal. Allow the trace to stabilize. Set the spectrum analyzer marker to the highest level of the displayed trace.  
(this is the reference value)
6. Determine the “-26 dB down amplitude” as equal to (Reference Value – X).
7. Place two markers, one at the lowest and the other at the highest frequency of the envelope of the spectral display such that each marker is at or slightly below the “-X dB down amplitude” determined in step 6. If a marker is below this “-X dB down amplitude” value it shall be placed as close as possible to this value. The OBW is the positive frequency difference between the two markers.
8. Use the 99 % power bandwidth function of the spectrum analyzer and report the measured bandwidth.





### 3.5 Conducted Band Edge

#### 3.5.1 Description of Conducted Band Edge Measurement

22.917(a)

For operations in the 824 – 849 MHz band, the FCC limit is  $43 + 10\log_{10}(P[\text{Watts}])$  dB below the transmitter power  $P(\text{Watts})$  in a 100kHz bandwidth. However, in the 1MHz bands immediately outside and adjacent to the licensee's frequency block, a resolution bandwidth of at least one percent of the emission bandwidth of the fundamental emission of the transmitter may be employed.

24.238 (a)

For operations in the 1850-1910 and 1930-1990 MHz band, the FCC limit is  $43 + 10\log_{10}(P[\text{Watts}])$  dB below the transmitter power  $P(\text{Watts})$  in a 1MHz bandwidth. However, in the 1 MHz bands immediately outside and adjacent to the frequency block a resolution bandwidth of at least one percent of the emission bandwidth of the fundamental emission of the transmitter may be employed.

27.53 (g)

For operations in the 600MHz band and 698-746 MHz band, the FCC limit is  $43 + 10\log_{10}(P[\text{Watts}])$  dB below the transmitter power  $P(\text{Watts})$  in a 100 kHz bandwidth. However, in the 100 kilohertz bands immediately outside and adjacent to a licensee's frequency block, a resolution bandwidth of at least 30 kHz may be employed.

27.53 (h)

For operations in the 1710 – 1755 MHz band, 1755-1780 MHz, the FCC limit is  $43 + 10\log_{10}(P[\text{Watts}])$  dB below the transmitter power  $P(\text{Watts})$  in a 1 MHz bandwidth. However, in the 1MHz bands immediately outside and adjacent to the licensee's frequency block, a resolution bandwidth of at least one percent of the emission bandwidth of the fundamental emission of the transmitter may be employed.

**27.53(m)(4)**

For mobile digital stations, the attenuation factor shall be not less than  $40 + 10 \log (P)$  dB on all frequencies between the channel edge and 5 megahertz from the channel edge,  $43 + 10 \log (P)$  dB on all frequencies between 5 megahertz and X megahertz from the channel edge, and  $55 + 10 \log (P)$  dB on all frequencies more than X megahertz from the channel edge, where X is the greater of 6 megahertz or the actual emission bandwidth as defined in paragraph (m)(6) of this section. In addition, the attenuation factor shall not be less that  $43 + 10 \log (P)$  dB on all frequencies between 2490.5 MHz and 2496 MHz and  $55 + 10 \log (P)$  dB at or below 2490.5 MHz. Mobile Satellite Service licensees operating on frequencies below 2495 MHz may also submit a documented interference complaint against BRS licensees operating on channel BRS Channel 1 on the same terms and conditions as adjacent channel BRS or EBS licensees.

**3.5.2 Test Procedures**

The testing follows FCC KDB 971168 D01 v03r01 Section 6.1.

1. The EUT was connected to spectrum analyzer and system simulator via a power divider.
2. The band edges of low and high channels for the highest RF powers were measured.
3. Set RBW  $\geq$  1% EBW in the 1MHz band immediately outside and adjacent to the band edge.
4. Beyond the 1 MHz band from the band edge, RBW=1MHz was used.
5. Set spectrum analyzer with RMS detector.
6. The RF fundamental frequency should be excluded against the limit line in the operating frequency band.
7. Checked that all the results comply with the emission limit line.

The limit line is derived from  $43 + 10\log(P)$ dB below the transmitter power P(Watts)

For LTE Band 7

The other 40 dB, and 55 dB have additionally applied same calculation above.



## **3.6 Frequency Stability**

### **3.6.1 Description of Frequency Stability Measurement**

22.355

The frequency stability shall be measured by variation of ambient temperature and variation of primary supply voltage to ensure that the fundamental emission stays within the authorized frequency block. The frequency stability of the transmitter shall be maintained within  $\pm 0.00025\%$  ( $\pm 2.5\text{ppm}$ ) of the center frequency.

24.235 & 27.54

The frequency stability shall be sufficient to ensure that the fundamental emission stays within the authorized frequency block.

### **3.6.2 Test Procedures for Temperature Variation**

The testing follows FCC KDB 971168 D01 v03r01 Section 9.0.

1. The EUT was set up in the thermal chamber and connected with the system simulator.
2. With power OFF, the temperature was decreased to  $-30^{\circ}\text{C}$  and the EUT was stabilized before testing. Power was applied and the maximum change in frequency was recorded within one minute.
3. With power OFF, the temperature was raised in  $10^{\circ}\text{C}$  step up to  $50^{\circ}\text{C}$ . The EUT was stabilized at each step for at least half an hour. Power was applied and the maximum frequency change was recorded within one minute.

### **3.6.3 Test Procedures for Voltage Variation**

The testing follows FCC KDB 971168 D01 v03r01 Section 9.0.

1. The EUT was placed in a temperature chamber at  $20\pm 5^{\circ}\text{C}$  and connected with the system simulator.
2. The power supply voltage to the EUT was varied from 85% to 115% of the nominal value measured at the input to the EUT.
3. The variation in frequency was measured for the worst case.

## 4 Radiated Test Items

### 4.1 Measuring Instruments

See list of measuring instruments of this test report.

#### 4.1.1 Test Setup

For radiated test below 30MHz

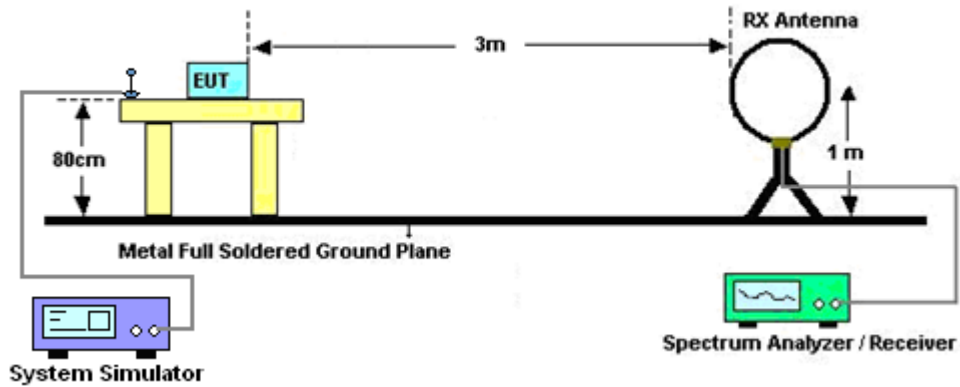

For radiated test from 30MHz to 1GHz

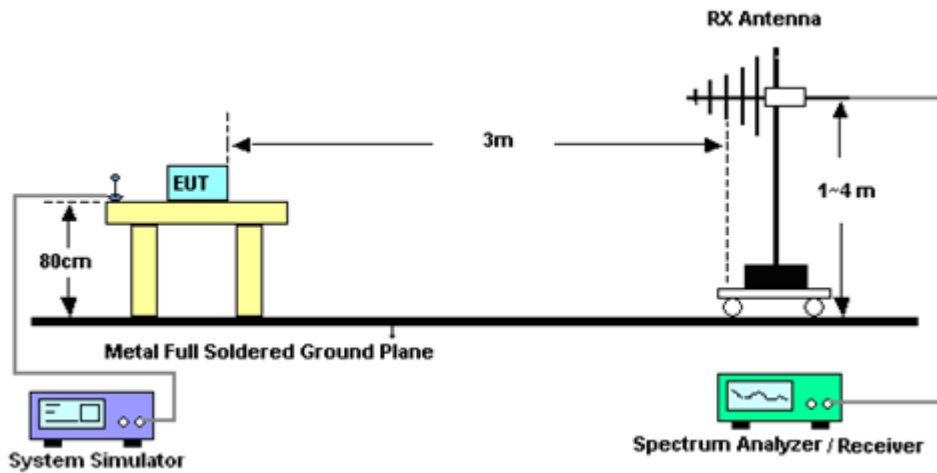

For radiated test above 1GHz

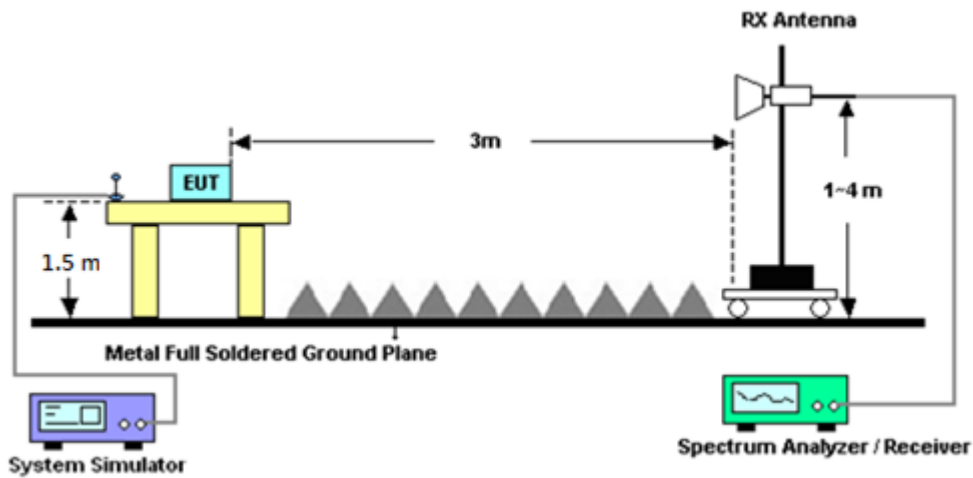

#### 4.1.2 Test Result of Radiated Test

Please refer to Appendix B.

**Note:**

The low frequency, which started from 9 kHz to 30MHz, was pre-scanned and the result which was 20dB lower than the limit line was not reported.

There is adequate comparison measurement of both open-field test site and alternative test site - semi-Anechoic chamber according to 414788 D01 Radiated Test Site v01r01, and the result came out very similar.



## 4.2 Radiated Spurious Emission Measurement

### 4.2.1 Description of Radiated Spurious Emission Measurement

The radiated spurious emission was measured by substitution method according to ANSI / TIA-603-E. The power of any emission outside of the authorized operating frequency ranges must be attenuated below the transmitter power (P) by a factor of at least  $43 + 10 \log (P)$  dB.

For LTE Band 7

The power of any emission outside of the authorized operating frequency ranges must be attenuated below the transmitter power (P) by a factor of at least  $55 + 10 \log (P)$  dB.

The spectrum is scanned from 30 MHz up to a frequency including its 10th harmonic.

### 4.2.2 Test Procedures

The testing follows FCC KDB 971168 D01 v03r01 Section 7 and ANSI / TIA-603-E Section 2.2.12.

1. The EUT was placed on a turntable with 0.8 meter for frequency below 1GHz and 1.5 meter for frequency above 1GHz respectively above ground.
2. The EUT was set 3 meters from the receiving antenna, which was mounted on the antenna tower.
3. The table was rotated 360 degrees to determine the position of the highest spurious emission.
4. The height of the receiving antenna is varied between one meter and four meters to search the maximum spurious emission for both horizontal and vertical polarizations.
5. Make the measurement with the spectrum analyzer's RBW = 1MHz, VBW = 3MHz, taking the record of maximum spurious emission.
6. A horn antenna was substituted in place of the EUT and was driven by a signal generator.
7. Tune the output power of signal generator to the same emission level with EUT maximum spurious emission.
8. Taking the record of output power at antenna port.
9. Repeat step 7 to step 8 for another polarization.
10. The RF fundamental frequency should be excluded against the limit line in the operating frequency band.

The limit line is derived from  $43 + 10\log(P)$ dB below the transmitter power P(Watts)

For LTE Band 7

The limit line is derived from  $55 + 10\log(P)$ dB below the transmitter power P(Watts)

EIRP (dBm) = S.G. Power – Tx Cable Loss + Tx Antenna Gain

ERP (dBm) = EIRP - 2.15



## 5 List of Measuring Equipment

Instrument	Brand Name	Model No.	Serial No.	Characteristics	Calibration Date	Test Date	Due Date	Remark
Amplifier	Sonoma-Instrument	310 N	187282	9KHz~1GHz	Dec. 16, 2020	Oct. 13, 2021~ Oct. 15, 2021	Dec. 15, 2021	Radiation (03CH13-HY)
Loop Antenna	Rohde & Schwarz	HFH2-Z2	100488	9 kHz~30 MHz	Sep. 07, 2021	Oct. 13, 2021~ Oct. 15, 2021	Sep. 06, 2022	Radiation (03CH13-HY)
Bilog Antenna	TESEQ	CBL 6111D&00800 N1D01N-06	40103&07	30MHz to 1GHz	Apr. 28, 2021	Oct. 13, 2021~ Oct. 15, 2021	Apr. 27, 2022	Radiation (03CH13-HY)
Bilog Antenna	TESEQ	CBL 6111D&00800 N1D01N-06	41912 & 05	30MHz to 1GHz	Feb. 08, 2021	Oct. 13, 2021~ Oct. 15, 2021	Feb. 07, 2022	Radiation (03CH13-HY)
Horn Antenna	SCHWARZBECK	BBHA 9120 D	9120D-1212	1GHz ~ 18GHz	May 18, 2021	Oct. 13, 2021~ Oct. 15, 2021	May 17, 2022	Radiation (03CH13-HY)
Horn Antenna	SCHWARZBECK	BBHA 9120 D	9120D-1241	1GHz ~ 18GHz	Jul. 13, 2021	Oct. 13, 2021~ Oct. 15, 2021	Jul. 12, 2022	Radiation (03CH13-HY)
Preamplifier	MITEQ	AMF-7D-0010 1800-30-10P	1590074	1GHz~18GHz	May 18, 2021	Oct. 13, 2021~ Oct. 15, 2021	May 17, 2022	Radiation (03CH13-HY)
Preamplifier	Keysight	83017A	MY53270147	1GHz~26.5GHz	Oct. 27, 2020	Oct. 13, 2021~ Oct. 15, 2021	Oct. 26, 2021	Radiation (03CH13-HY)
Signal Generator	Anritsu	MG3694C	163401	0.1Hz~40GHz	Jan. 31, 2021	Oct. 13, 2021~ Oct. 15, 2021	Jan. 30, 2022	Radiation (03CH13-HY)
Spectrum Analyzer	Keysight	N9010A	MY55370526	10Hz~44GHz	Mar. 18, 2021	Oct. 13, 2021~ Oct. 15, 2021	Mar. 17, 2022	Radiation (03CH13-HY)
Controller	EMEC	EM1000	N/A	Control Turn table & Ant Mast	N/A	Oct. 13, 2021~ Oct. 15, 2021	N/A	Radiation (03CH13-HY)
Antenna Mast	EMEC	AM-BS-4500-B	N/A	1m~4m	N/A	Oct. 13, 2021~ Oct. 15, 2021	N/A	Radiation (03CH13-HY)
Turn Table	EMEC	TT2000	N/A	0~360 Degree	N/A	Oct. 13, 2021~ Oct. 15, 2021	N/A	Radiation (03CH13-HY)
Software	Audix	E3 6.2009-8-24	RK-000992	N/A	N/A	Oct. 13, 2021~ Oct. 15, 2021	N/A	Radiation (03CH13-HY)
Preamplifier	EMEC	EM18G40G	060715	18GHz ~ 40GHz	Dec. 11, 2020	Oct. 13, 2021~ Oct. 15, 2021	Dec. 10, 2021	Radiation (03CH13-HY)
RF Cable	HUBER + SUHNER	SUCOFLEX 126E	0030/126E	30M-18G	Feb. 10, 2021	Oct. 13, 2021~ Oct. 15, 2021	Feb. 09, 2022	Radiation (03CH13-HY)
RF Cable	HUBER + SUHNER	SUCOFLEX 104	804793/4	30M-18G	Feb. 10, 2021	Oct. 13, 2021~ Oct. 15, 2021	Feb. 09, 2022	Radiation (03CH13-HY)
RF Cable	HUBER + SUHNER	SUCOFLEX 102	505134/2	30M~40GHz	Feb. 22, 2021	Oct. 13, 2021~ Oct. 15, 2021	Feb. 21, 2022	Radiation (03CH13-HY)
RF Cable	HUBER + SUHNER	SUCOFLEX 102	MY4274/2	30MHz~40GHz	Mar. 11, 2021	Oct. 13, 2021~ Oct. 15, 2021	Mar. 10, 2022	Radiation (03CH13-HY)
RF Cable	HUBER + SUHNER	SUCOFLEX 104	MY24961/4	30M-18G	Feb. 10, 2021	Oct. 13, 2021~ Oct. 15, 2021	Feb. 09, 2022	Radiation (03CH13-HY)
RF Cable	HUBER + SUHNER	SUCOFLEX 104	MY9837/4PE	9kHz~30MHz	Mar. 11, 2021	Oct. 13, 2021~ Oct. 15, 2021	Mar. 10, 2022	Radiation (03CH13-HY)
SHF-EHF Horn Antenna	SCHWARZBECK	BBHA 9170	BBHA917058 4	18GHz- 40GHz	Dec. 11, 2020	Oct. 13, 2021~ Oct. 15, 2021	Dec. 10, 2021	Radiation (03CH13-HY)
SHF-EHF Horn Antenna	SCHWARZBECK	BBHA 9170	BBHA917098 0	18GHz~40GHz	Jan. 11, 2021	Oct. 13, 2021~ Oct. 15, 2021	Jan. 10, 2022	Radiation (03CH13-HY)
Filter	Wainwright	WHKX12-2700 -3000-18000-6 0SS	SN2	3GHz High Pass Filter	Jul. 12, 2021	Oct. 13, 2021~ Oct. 15, 2021	Jul. 11, 2022	Radiation (03CH13-HY)
Filter	Wainwright	WHKX12-1080 -1200-15000-6 0SS	SN3	1.2GHz High Pass Filter	Jul. 01, 2021	Oct. 13, 2021~ Oct. 15, 2021	Jun. 30, 2022	Radiation (03CH13-HY)
Hygrometer	TECPEL	DTM-303A	TP200889	N/A	Oct. 22, 2020	Oct. 13, 2021~ Oct. 15, 2021	Oct. 21, 2021	Radiation (03CH13-HY)



Instrument	Brand Name	Model No.	Serial No.	Characteristics	Calibration Date	Test Date	Due Date	Remark
Radio Communication Analyzer	Anritsu	MT8821C	6272278356	N/A	Aug. 05, 2021	Oct. 12, 2021~ Oct. 14, 2021	Aug. 04, 2022	Conducted (TH03-HY)
Spectrum Analyzer	Rohde & Schwarz	FSV40	101397	10Hz~40GHz	Nov. 27, 2020	Oct. 12, 2021~ Oct. 14, 2021	Nov. 26, 2021	Conducted (TH03-HY)
Thermal Chamber	Ten Billion	TTH-D3SP	TBN-930701	N/A	Nov. 13, 2020	Oct. 12, 2021~ Oct. 14, 2021	Nov. 12, 2021	Conducted (TH03-HY)
Programmable Power Supply	GW Instek	PSS-2005	EL890001	1V~20V 0.5A~4A	Oct. 06, 2021	Oct. 12, 2021~ Oct. 14, 2021	Oct. 05, 2022	Conducted (TH03-HY)
Coupler	Warison	20dB 25W SMA Directional Coupler	#B	1-18GHz	Jan. 09, 2021	Oct. 12, 2021~ Oct. 14, 2021	Jan. 08, 2022	Conducted (TH03-HY)





## 6 Uncertainty of Evaluation

### Uncertainty of Radiated Emission Measurement (30 MHz ~ 1000 MHz)

Measuring Uncertainty for a Level of Confidence of 95% ( $U = 2Uc(y)$ )	3.45 dB
---	---------

### Uncertainty of Radiated Emission Measurement (1 GHz ~ 18 GHz)

Measuring Uncertainty for a Level of Confidence of 95% ( $U = 2Uc(y)$ )	3.73 dB
---	---------

### Uncertainty of Radiated Emission Measurement (18 GHz ~ 40 GHz)

Measuring Uncertainty for a Level of Confidence of 95% ( $U = 2Uc(y)$ )	4.00 dB
---	---------



## Appendix A. Test Results of Conducted Test

### Conducted Output Power(Average power & ERP/EIRP)

LTE Band 2 Maximum Average Power [dBm]								
BW [MHz]	RB Size	RB Offset	Mod	Lowest	Middle	Highest	EIRP (dBm)	EIRP (W)
20	1	0	16-QAM	21.15	21.11	21.18	22.58	0.1811
20	1	49		21.57	21.58	21.41		
20	1	99		21.36	21.32	21.22		
20	50	0		20.36	20.38	20.21		
20	50	24		20.64	20.61	20.49		
20	50	50		20.55	20.57	20.49		
20	100	0		20.42	20.41	20.27		
Limit	EIRP < 2W			Result			Pass	

LTE Band 2 Maximum Average Power [dBm]								
BW [MHz]	RB Size	RB Offset	Mod	Lowest	Middle	Highest	EIRP (dBm)	EIRP (W)
15	1	0	16-QAM	21.15	21.03	21.18	22.55	0.1799
15	1	37		21.55	21.49	21.34		
15	1	74		21.27	21.26	21.15		
15	36	0		20.32	20.33	20.15		
15	36	20		20.55	20.54	20.40		
15	36	39		20.53	20.50	20.41		
15	75	0		20.34	20.32	20.17		
Limit	EIRP < 2W			Result			Pass	

LTE Band 2 Maximum Average Power [dBm]								
BW [MHz]	RB Size	RB Offset	Mod	Lowest	Middle	Highest	EIRP (dBm)	EIRP (W)
10	1	0	16-QAM	21.15	21.08	21.08	22.52	0.1786
10	1	25		21.51	21.52	21.36		
10	1	49		21.27	21.26	21.14		
10	25	0		20.28	20.29	20.16		
10	25	12		20.56	20.58	20.45		
10	25	25		20.52	20.51	20.39		
10	50	0		20.38	20.38	20.19		
Limit	EIRP < 2W			Result			Pass	



LTE Band 2 Maximum Average Power [dBm]								
BW [MHz]	RB Size	RB Offset	Mod	Lowest	Middle	Highest	EIRP (dBm)	EIRP (W)
5	1	0	16-QAM	21.14	21.11	21.15	22.57	0.1807
5	1	12		21.57	21.54	21.36		
5	1	24		21.36	21.32	21.13		
5	12	0		20.34	20.28	20.20		
5	12	7		20.63	20.52	20.40		
5	12	13		20.46	20.50	20.43		
5	25	0		20.41	20.34	20.22		
Limit	EIRP < 2W			Result			Pass	

LTE Band 2 Maximum Average Power [dBm]								
BW [MHz]	RB Size	RB Offset	Mod	Lowest	Middle	Highest	EIRP (dBm)	EIRP (W)
3	1	0	16-QAM	21.15	21.07	21.10	22.55	0.1799
3	1	8		21.47	21.55	21.34		
3	1	14		21.34	21.26	21.17		
3	8	0		20.33	20.33	20.18		
3	8	4		20.61	20.55	20.41		
3	8	7		20.55	20.51	20.44		
3	15	0		20.32	20.38	20.20		
Limit	EIRP < 2W			Result			Pass	

LTE Band 2 Maximum Average Power [dBm]								
BW [MHz]	RB Size	RB Offset	Mod	Lowest	Middle	Highest	EIRP (dBm)	EIRP (W)
1.4	1	0	16-QAM	21.12	21.09	21.18	22.57	0.1807
1.4	1	3		21.50	21.50	21.37		
1.4	1	5		21.30	21.28	21.15		
1.4	3	0		21.07	21.10	21.10		
1.4	3	1		21.54	21.57	21.34		
1.4	3	3		21.26	21.32	21.19		
1.4	6	0		20.27	20.34	20.15		
Limit	EIRP < 2W			Result			Pass	



LTE Band 4 Maximum Average Power [dBm]								
BW [MHz]	RB Size	RB Offset	Mod	Lowest	Middle	Highest	EIRP (dBm)	EIRP (W)
20	1	0	16-QAM	21.02	21.44	21.93	26.93	0.4932
20	1	49		21.19	21.68	21.68		
20	1	99		20.91	21.43	21.43		
20	50	0		20.40	20.91	20.91		
20	50	24		20.43	20.92	20.92		
20	50	50		20.25	20.74	20.74		
20	100	0		20.47	20.92	20.92		
Limit	EIRP < 1W			Result			Pass	

LTE Band 4 Maximum Average Power [dBm]								
BW [MHz]	RB Size	RB Offset	Mod	Lowest	Middle	Highest	EIRP (dBm)	EIRP (W)
15	1	0	16-QAM	20.98	21.38	21.83	26.83	0.4819
15	1	37		21.16	21.65	21.67		
15	1	74		20.89	21.35	21.43		
15	36	0		20.36	20.86	20.85		
15	36	20		20.36	20.85	20.87		
15	36	39		20.22	20.68	20.74		
15	75	0		20.46	20.87	20.84		
Limit	EIRP < 1W			Result			Pass	

LTE Band 4 Maximum Average Power [dBm]								
BW [MHz]	RB Size	RB Offset	Mod	Lowest	Middle	Highest	EIRP (dBm)	EIRP (W)
10	1	0	16-QAM	20.96	21.35	21.85	26.85	0.4842
10	1	25		21.15	21.61	21.67		
10	1	49		20.88	21.38	21.40		
10	25	0		20.34	20.89	20.81		
10	25	12		20.37	20.90	20.84		
10	25	25		20.24	20.70	20.74		
10	50	0		20.37	20.88	20.91		
Limit	EIRP < 1W			Result			Pass	



LTE Band 4 Maximum Average Power [dBm]								
BW [MHz]	RB Size	RB Offset	Mod	Lowest	Middle	Highest	EIRP (dBm)	EIRP (W)
5	1	0	16-QAM	20.97	21.43	21.86	26.86	0.4853
5	1	12		21.16	21.65	21.63		
5	1	24		20.85	21.34	21.40		
5	12	0		20.30	20.86	20.88		
5	12	7		20.33	20.89	20.84		
5	12	13		20.22	20.72	20.68		
5	25	0		20.41	20.83	20.91		
Limit	EIRP < 1W			Result			Pass	

LTE Band 4 Maximum Average Power [dBm]								
BW [MHz]	RB Size	RB Offset	Mod	Lowest	Middle	Highest	EIRP (dBm)	EIRP (W)
3	1	0	16-QAM	21.02	21.41	21.86	26.86	0.4853
3	1	8		21.13	21.59	21.65		
3	1	14		20.81	21.41	21.40		
3	8	0		20.39	20.88	20.81		
3	8	4		20.39	20.92	20.86		
3	8	7		20.16	20.65	20.71		
3	15	0		20.37	20.83	20.84		
Limit	EIRP < 1W			Result			Pass	

LTE Band 4 Maximum Average Power [dBm]								
BW [MHz]	RB Size	RB Offset	Mod	Lowest	Middle	Highest	EIRP (dBm)	EIRP (W)
1.4	1	0	16-QAM	21.01	21.35	21.90	26.90	0.4898
1.4	1	3		21.13	21.65	21.59		
1.4	1	5		20.90	21.40	21.37		
1.4	3	0		21.02	21.36	21.84		
1.4	3	1		21.15	21.59	21.58		
1.4	3	3		20.88	21.40	21.36		
1.4	6	0		20.36	20.89	20.86		
Limit	EIRP < 1W			Result			Pass	



LTE Band 5 Maximum Average Power [dBm]								
BW [MHz]	RB Size	RB Offset	Mod	Lowest	Middle	Highest	ERP (dBm)	ERP (W)
10	1	0	16-QAM	21.81	21.34	21.19	20.66	0.1164
10	1	25		21.78	21.38	21.51		
10	1	49		21.45	21.00	21.06		
10	25	0		21.20	20.74	20.87		
10	25	12		21.02	20.56	20.63		
10	25	25		20.76	20.30	20.41		
10	50	0		20.92	20.48	20.55		
Limit	ERP < 7W			Result			Pass	

LTE Band 5 Maximum Average Power [dBm]								
BW [MHz]	RB Size	RB Offset	Mod	Lowest	Middle	Highest	ERP (dBm)	ERP (W)
5	1	0	16-QAM	21.78	21.30	21.19	20.63	0.1156
5	1	12		21.68	21.35	21.42		
5	1	24		21.45	20.90	21.01		
5	12	0		21.20	20.69	20.81		
5	12	7		21.02	20.47	20.56		
5	12	13		20.68	20.29	20.41		
5	25	0		20.83	20.41	20.48		
Limit	ERP < 7W			Result			Pass	

LTE Band 5 Maximum Average Power [dBm]								
BW [MHz]	RB Size	RB Offset	Mod	Lowest	Middle	Highest	ERP (dBm)	ERP (W)
3	1	0	16-QAM	21.80	21.25	21.11	20.65	0.1161
3	1	8		21.74	21.28	21.44		
3	1	14		21.43	21.00	21.05		
3	8	0		21.13	20.65	20.80		
3	8	4		21.02	20.56	20.62		
3	8	7		20.66	20.23	20.41		
3	15	0		20.83	20.38	20.49		
Limit	ERP < 7W			Result			Pass	

LTE Band 5 Maximum Average Power [dBm]								
BW [MHz]	RB Size	RB Offset	Mod	Lowest	Middle	Highest	ERP (dBm)	ERP (W)
1.4	1	0	16-QAM	21.72	21.32	21.15	20.59	0.1146
1.4	1	3		21.74	21.33	21.47		
1.4	1	5		21.41	20.95	21.06		
1.4	3	0		21.72	21.28	21.18		
1.4	3	1		21.68	21.32	21.46		
1.4	3	3		21.39	20.97	20.98		
1.4	6	0		21.11	20.67	20.80		
Limit	ERP < 7W			Result			Pass	



LTE Band 7 Maximum Average Power [dBm]								
BW [MHz]	RB Size	RB Offset	Mod	Lowest	Middle	Highest	EIRP (dBm)	EIRP (W)
20	1	0	16-QAM	21.21	21.34	21.58	30.61	1.1508
20	1	49		21.38	21.61	21.36		
20	1	99		20.95	21.12	20.87		
20	50	0		20.55	20.68	20.43		
20	50	24		20.28	20.46	20.19		
20	50	50		20.23	20.40	20.09		
20	100	0		20.38	20.60	20.28		
Limit	EIRP < 2W			Result			Pass	

LTE Band 7 Maximum Average Power [dBm]								
BW [MHz]	RB Size	RB Offset	Mod	Lowest	Middle	Highest	EIRP (dBm)	EIRP (W)
15	1	0	16-QAM	21.18	21.24	21.53	30.53	1.1298
15	1	37		21.32	21.53	21.30		
15	1	74		20.89	21.04	20.87		
15	36	0		20.55	20.66	20.41		
15	36	20		20.21	20.42	20.13		
15	36	39		20.23	20.31	20.00		
15	75	0		20.31	20.58	20.18		
Limit	EIRP < 2W			Result			Pass	

LTE Band 7 Maximum Average Power [dBm]								
BW [MHz]	RB Size	RB Offset	Mod	Lowest	Middle	Highest	EIRP (dBm)	EIRP (W)
10	1	0	16-QAM	21.12	21.28	21.52	30.59	1.1455
10	1	25		21.35	21.59	21.30		
10	1	49		20.93	21.11	20.78		
10	25	0		20.55	20.61	20.39		
10	25	12		20.21	20.41	20.14		
10	25	25		20.22	20.32	20.02		
10	50	0		20.30	20.56	20.27		
Limit	EIRP < 2W			Result			Pass	

LTE Band 7 Maximum Average Power [dBm]								
BW [MHz]	RB Size	RB Offset	Mod	Lowest	Middle	Highest	EIRP (dBm)	EIRP (W)
5	1	0	16-QAM	21.18	21.30	21.51	30.56	1.1376
5	1	12		21.32	21.56	21.34		
5	1	24		20.87	21.03	20.84		
5	12	0		20.46	20.60	20.38		
5	12	7		20.24	20.44	20.19		
5	12	13		20.21	20.34	20.08		
5	25	0		20.31	20.55	20.21		
Limit	EIRP < 2W			Result			Pass	



LTE Band 12 Maximum Average Power [dBm]								
BW [MHz]	RB Size	RB Offset	Mod	Lowest	Middle	Highest	ERP (dBm)	ERP (W)
10	1	0	16-QAM	21.50	21.83	22.19	26.17	0.4140
10	1	25		22.46	22.82	22.43		
10	1	49		21.76	22.11	21.73		
10	25	0		20.89	21.25	20.87		
10	25	12		21.23	21.48	21.19		
10	25	25		21.02	21.44	21.01		
10	50	0		20.92	21.34	20.89		
Limit	ERP < 3W			Result			Pass	

LTE Band 12 Maximum Average Power [dBm]								
BW [MHz]	RB Size	RB Offset	Mod	Lowest	Middle	Highest	ERP (dBm)	ERP (W)
5	1	0	16-QAM	21.44	21.80	22.09	25.81	0.3811
5	1	12		22.44	22.46	22.38		
5	1	24		21.70	22.06	21.71		
5	12	0		20.79	21.16	20.82		
5	12	7		21.18	21.43	21.15		
5	12	13		20.98	21.37	20.94		
5	25	0		20.89	21.26	20.85		
Limit	ERP < 3W			Result			Pass	

LTE Band 12 Maximum Average Power [dBm]								
BW [MHz]	RB Size	RB Offset	Mod	Lowest	Middle	Highest	ERP (dBm)	ERP (W)
3	1	0	16-QAM	21.40	21.83	22.19	25.82	0.3819
3	1	8		22.45	22.47	22.37		
3	1	14		21.76	22.08	21.66		
3	8	0		20.88	21.23	20.80		
3	8	4		21.23	21.46	21.12		
3	8	7		21.02	21.40	20.93		
3	15	0		20.83	21.27	20.79		
Limit	ERP < 3W			Result			Pass	

LTE Band 12 Maximum Average Power [dBm]								
BW [MHz]	RB Size	RB Offset	Mod	Lowest	Middle	Highest	ERP (dBm)	ERP (W)
1.4	1	0	16-QAM	21.42	21.76	22.13	25.84	0.3837
1.4	1	3		22.38	22.46	22.41		
1.4	1	5		21.70	22.04	21.71		
1.4	3	0		21.43	21.80	22.09		
1.4	3	1		22.39	22.49	22.33		
1.4	3	3		21.72	22.01	21.63		
1.4	6	0		20.87	21.17	20.86		
Limit	ERP < 3W			Result			Pass	





## LTE Band 2

### Peak-to-Average Ratio

Mode	LTE Band 2 / 20MHz				
Mod.	QPSK	16QAM	64QAM	256QAM	Limit: 13dB
RB Size	Full RB	Full RB	Full RB	Full RB	Result
Middle CH	-	5.94	-	-	PASS

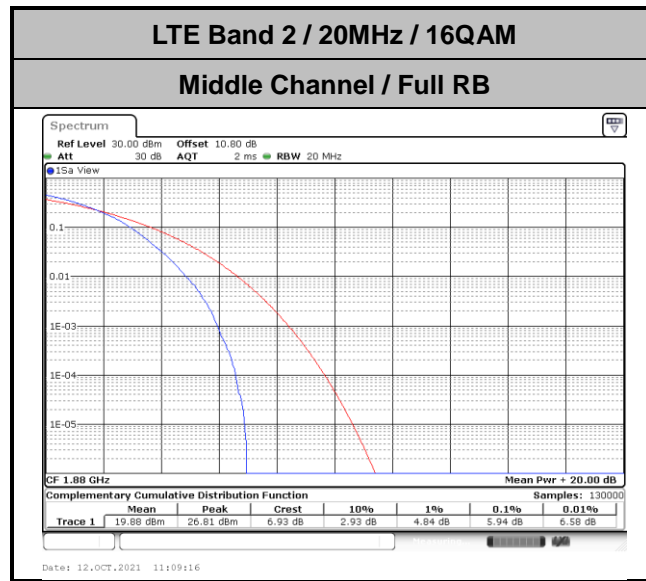



**26dB Bandwidth**

Mode	LTE Band 2 : 26dB BW(MHz)											
	1.4MHz		3MHz		5MHz		10MHz		15MHz		20MHz	
BW												
Mod.	QPSK	16QAM	QPSK	16QAM	QPSK	16QAM	QPSK	16QAM	QPSK	16QAM	QPSK	16QAM
Middle CH	-	1.27	-	3.02	-	4.94	-	9.81	-	14.30	-	18.98

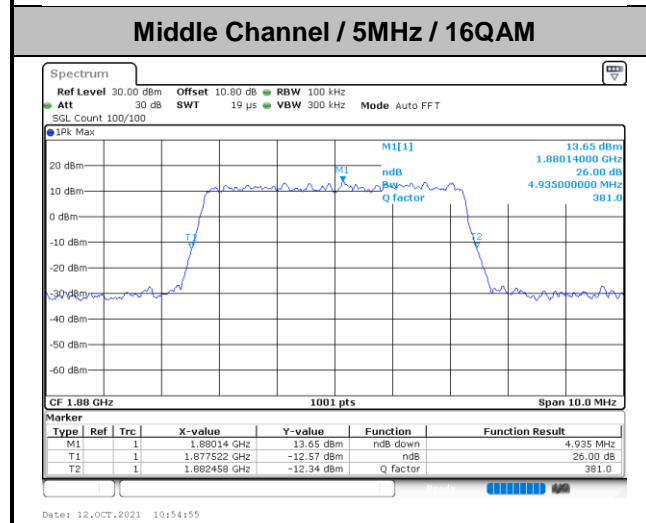
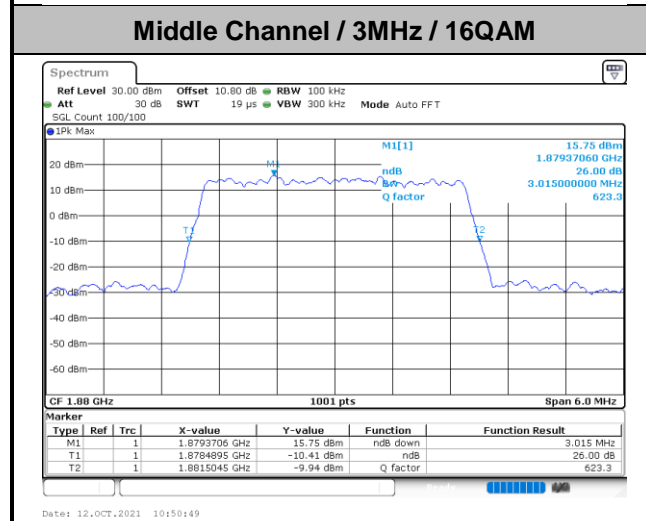
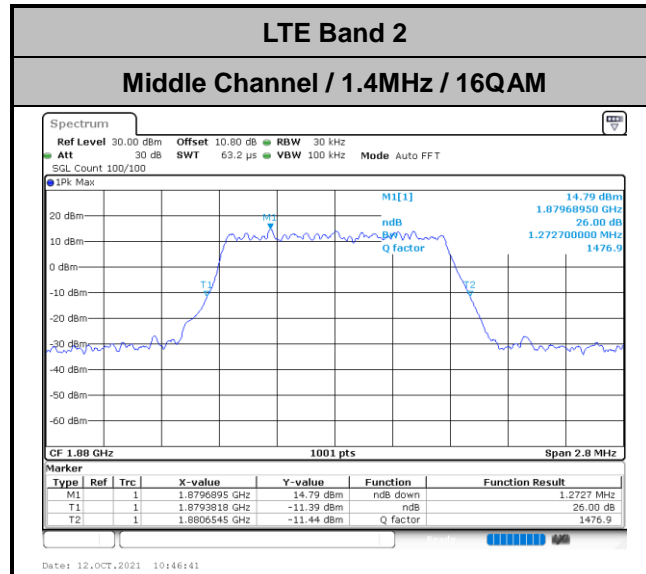

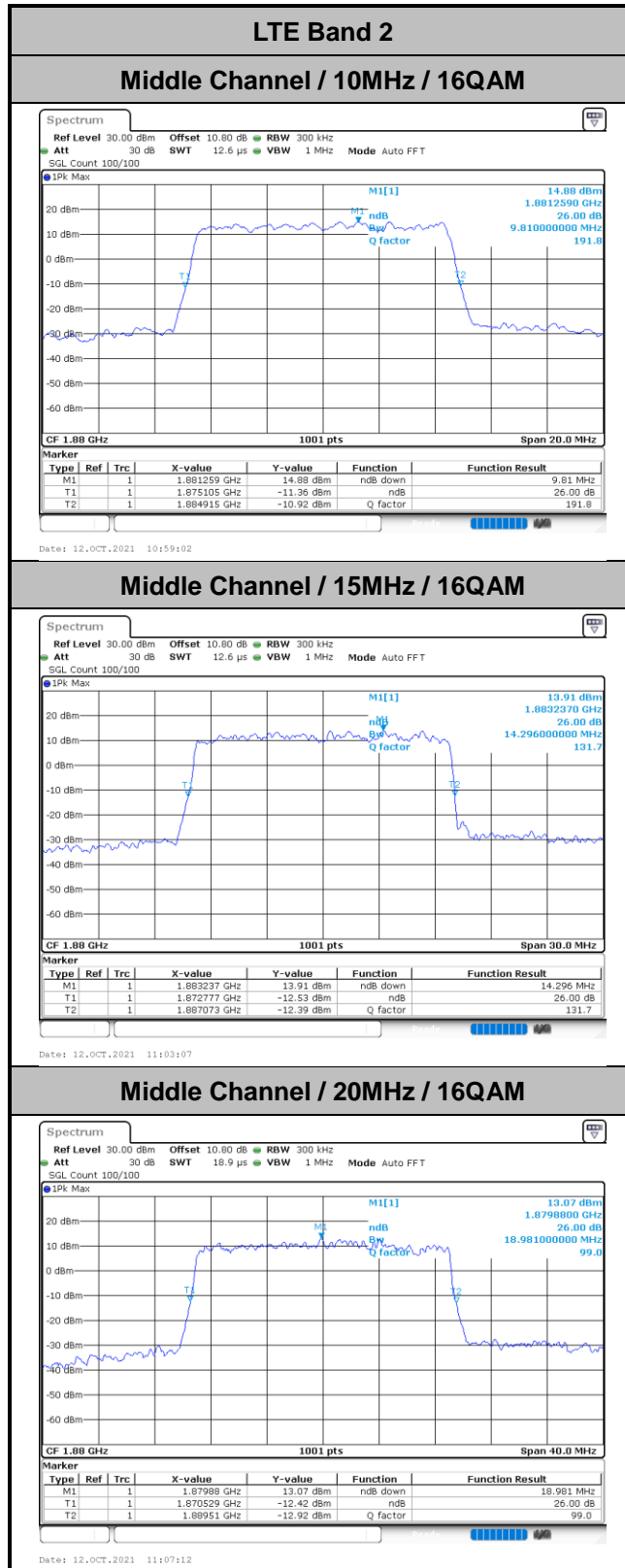



### Occupied Bandwidth

Mode	LTE Band 2 : 99%OBW(MHz)											
	1.4MHz		3MHz		5MHz		10MHz		15MHz		20MHz	
BW												
Mod.	QPSK	16QAM	QPSK	16QAM	QPSK	16QAM	QPSK	16QAM	QPSK	16QAM	QPSK	16QAM
Middle CH	-	1.09	-	2.75	-	4.50	-	8.99	-	13.37	-	17.98

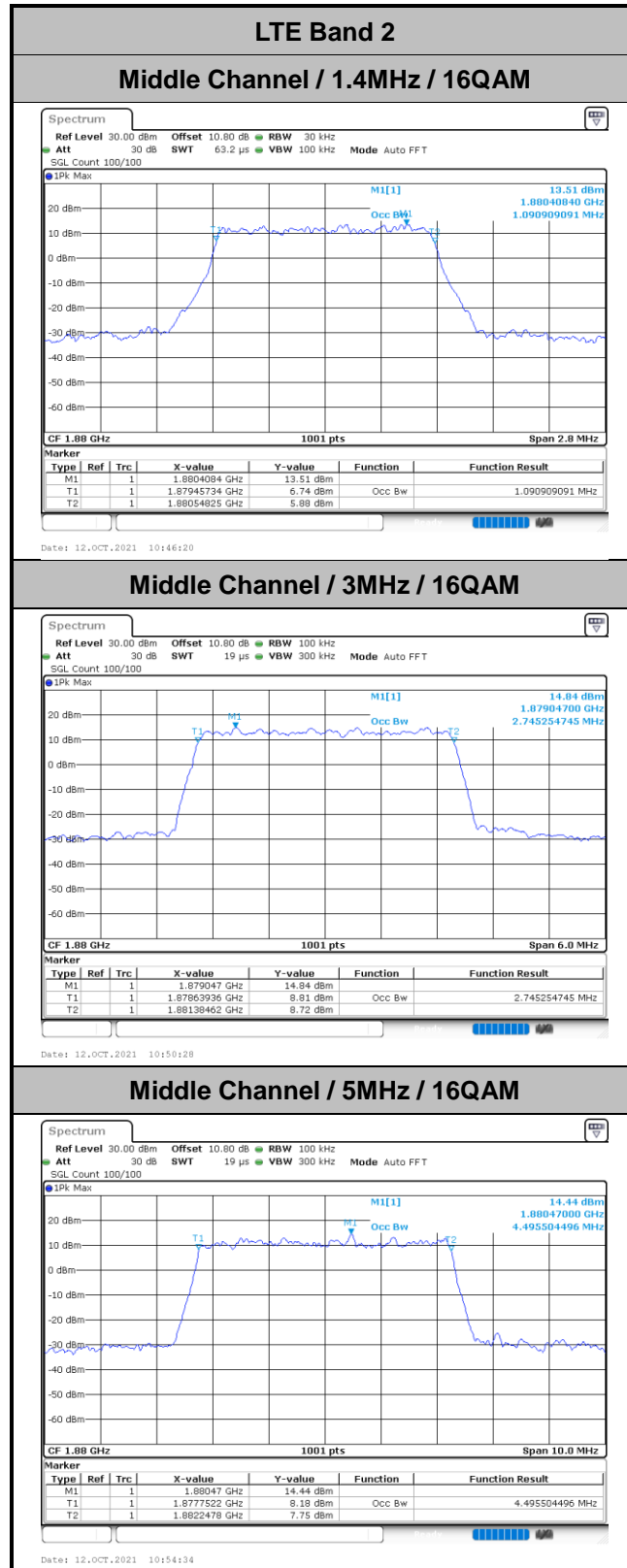

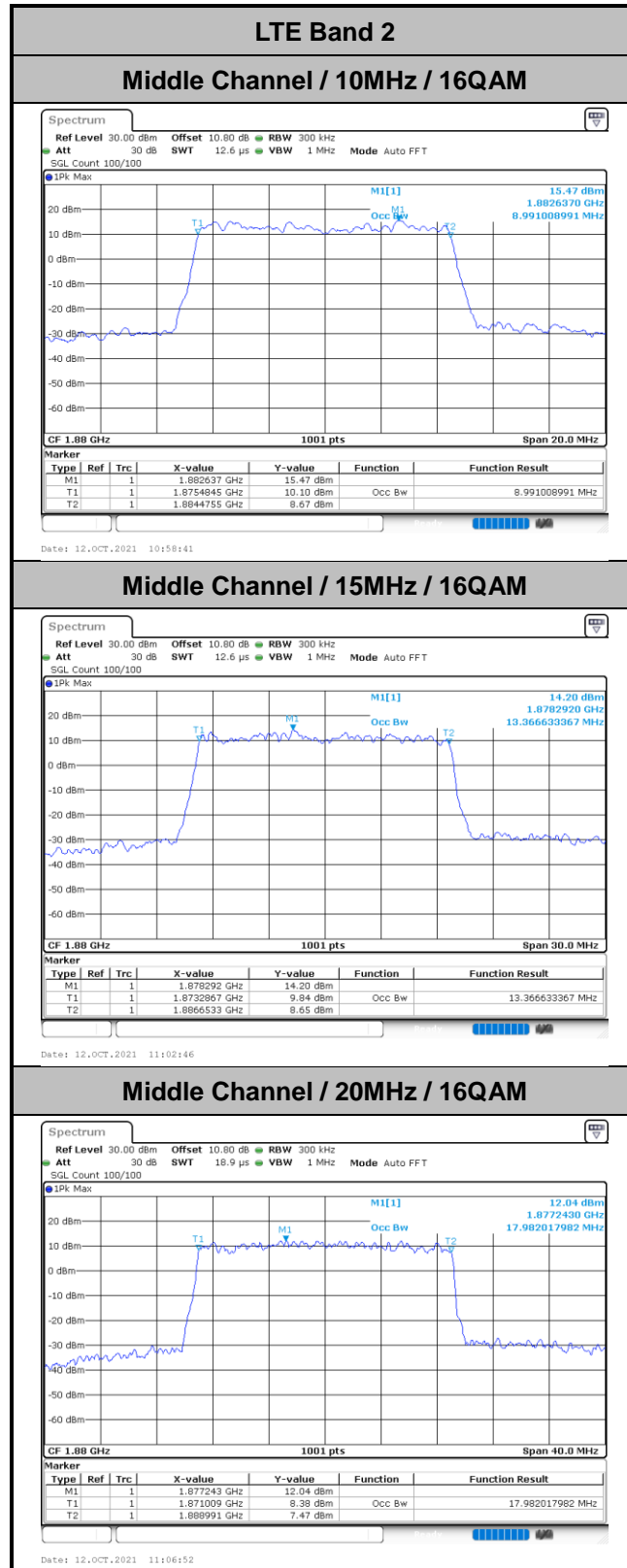



# Conducted Band Edge

## LTE Band 2 / 1.4MHz / 16QAM

### Lowest Band Edge / 1 RB

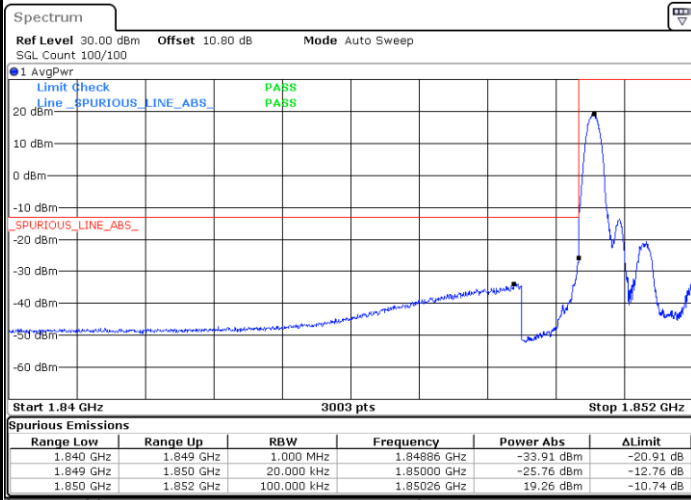

Date: 12.OCT.2021 10:45:08

### Highest Band Edge / 1 RB

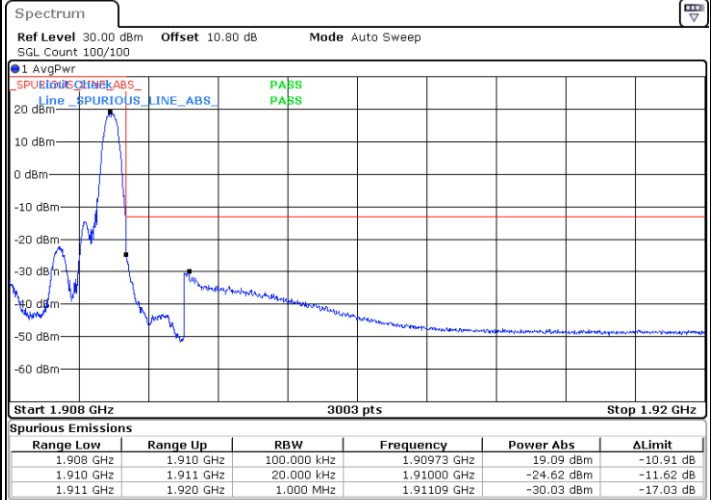

Date: 12.OCT.2021 10:47:31

### Lowest Band Edge / Full RB

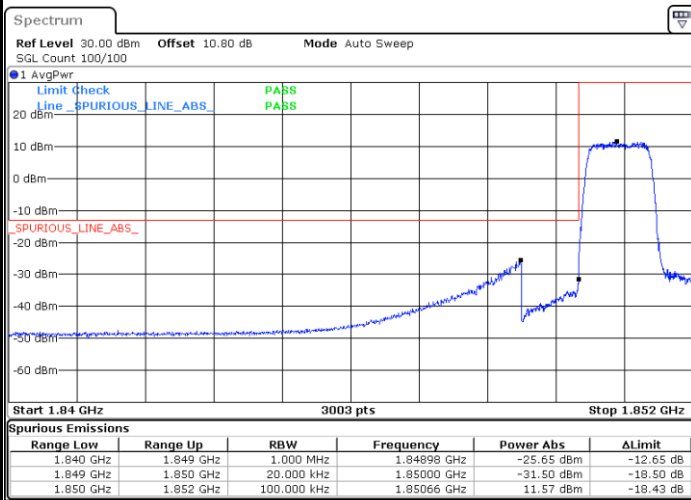

Date: 12.OCT.2021 10:45:59

### Highest Band Edge / Full RB

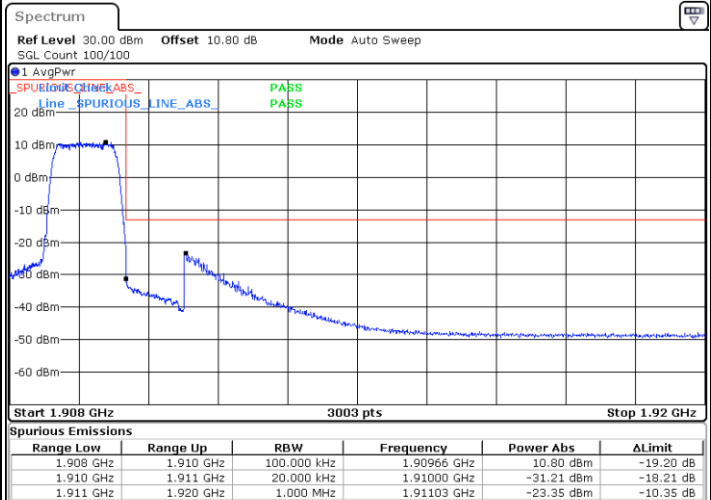

Date: 12.OCT.2021 10:48:22





LTE Band 2 / 3MHz / 16QAM

Lowest Band Edge / 1 RB

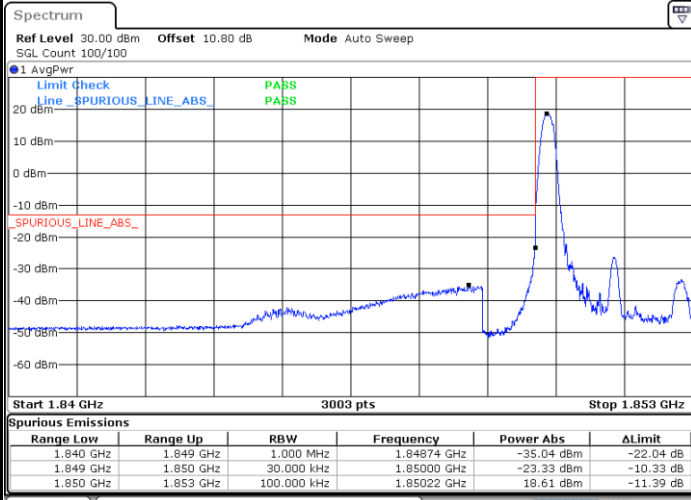

Date: 12.OCT.2021 10:49:13

Highest Band Edge / 1 RB

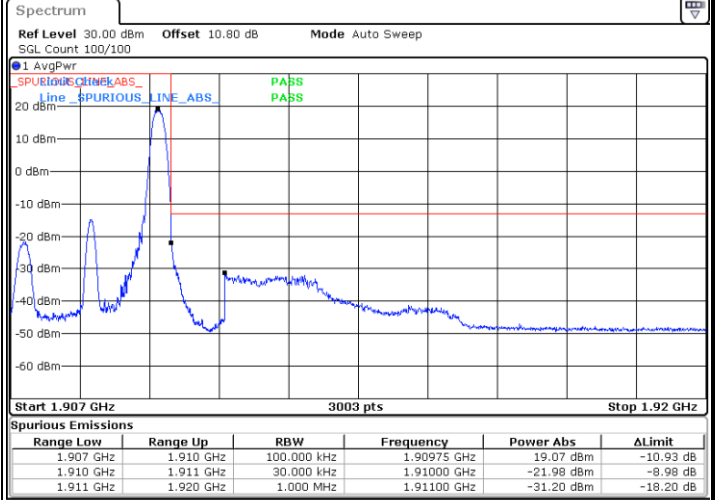

Date: 12.OCT.2021 10:51:40

Lowest Band Edge / Full RB

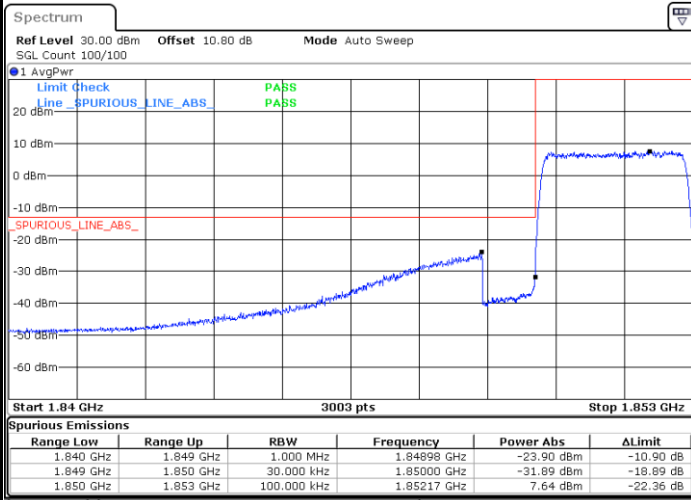

Date: 12.OCT.2021 10:50:06

Highest Band Edge / Full RB



Date: 12.OCT.2021 10:52:31



LTE Band 2 / 5MHz / 16QAM

Lowest Band Edge / 1RB

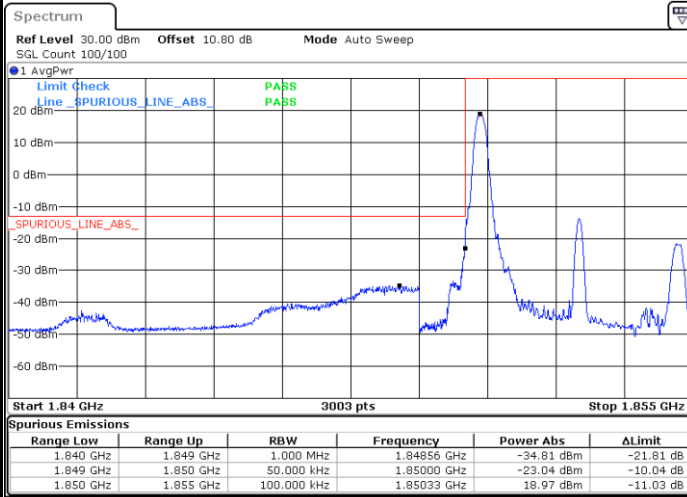

Date: 12.OCT.2021 10:53:22

Highest Band Edge / 1 RB

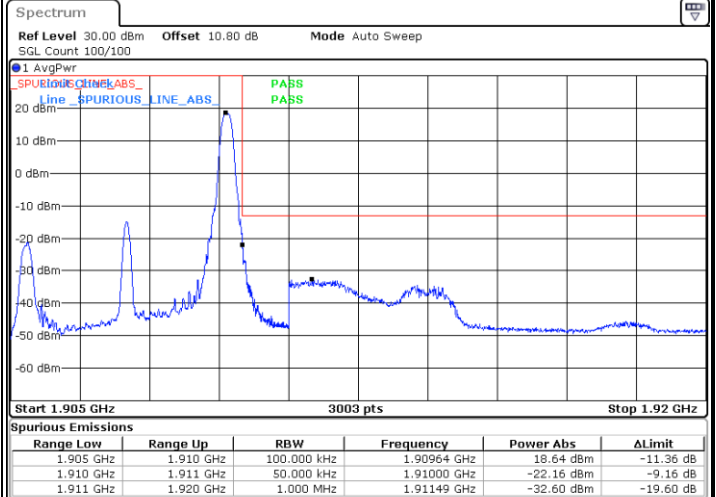

Date: 12.OCT.2021 10:55:46

Lowest Band Edge / Full RB

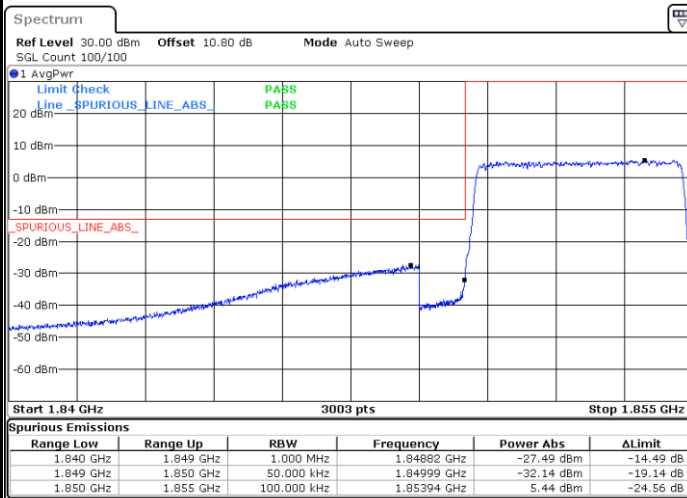

Date: 12.OCT.2021 10:54:13

Highest Band Edge / Full RB

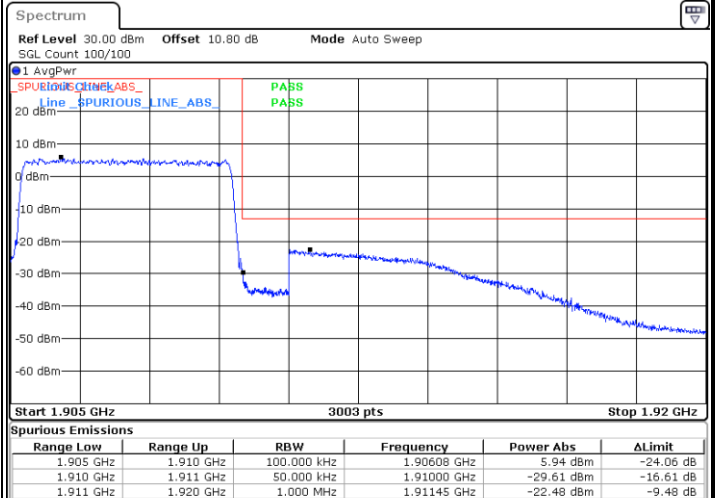

Date: 12.OCT.2021 10:56:36



LTE Band 2 / 10MHz / 16QAM

Lowest Band Edge / 1 RB

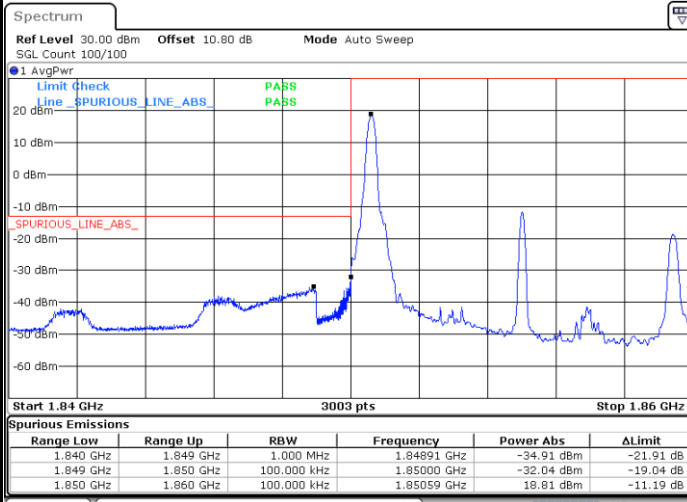

Date: 12.OCT.2021 10:57:28

Highest Band Edge / 1 RB

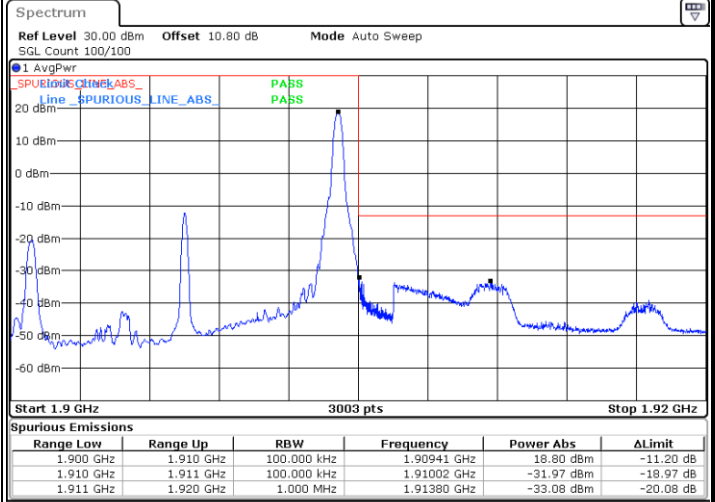

Date: 12.OCT.2021 10:59:52

Lowest Band Edge / Full RB

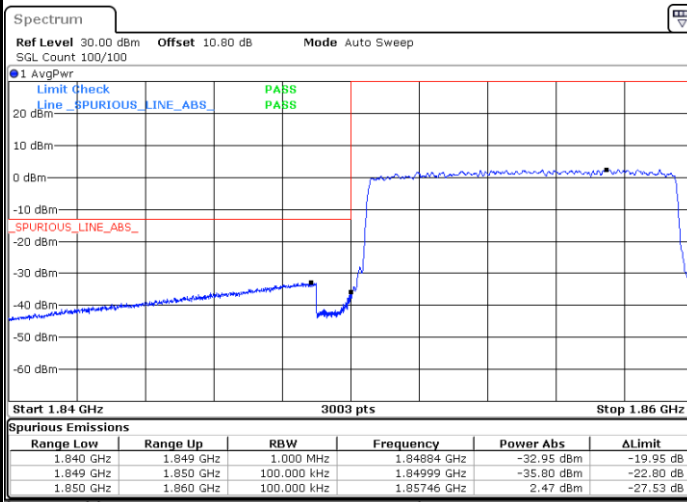

Date: 12.OCT.2021 10:58:19

Highest Band Edge / Full RB

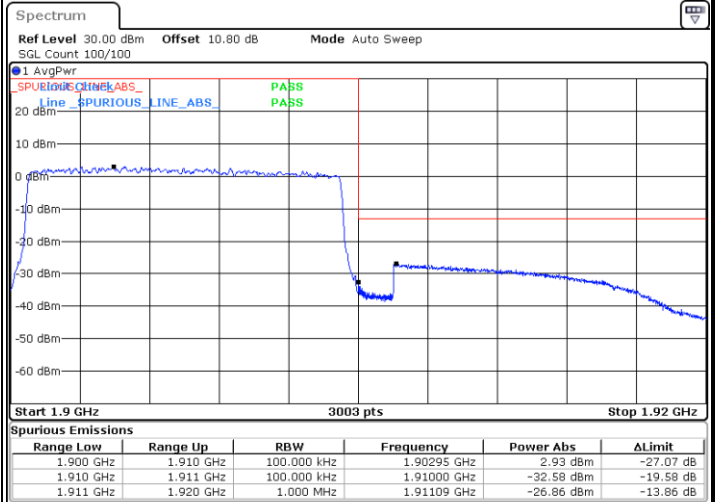

Date: 12.OCT.2021 11:00:43



LTE Band 2 / 15MHz / 16QAM

Lowest Band Edge / 1 RB

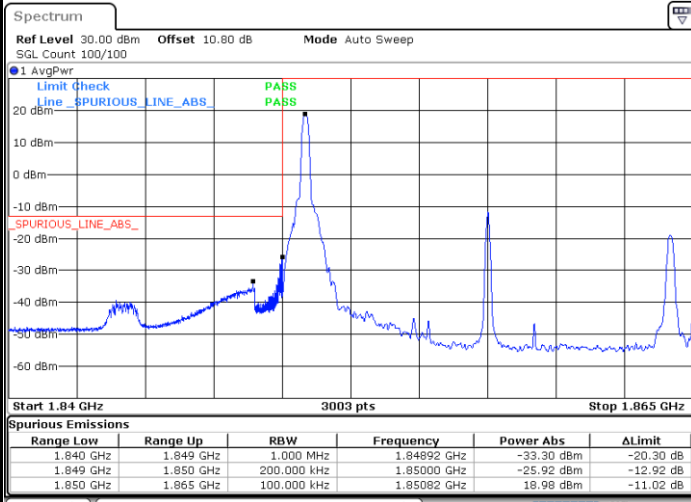

Date: 12.OCT.2021 11:01:34

Highest Band Edge / 1 RB

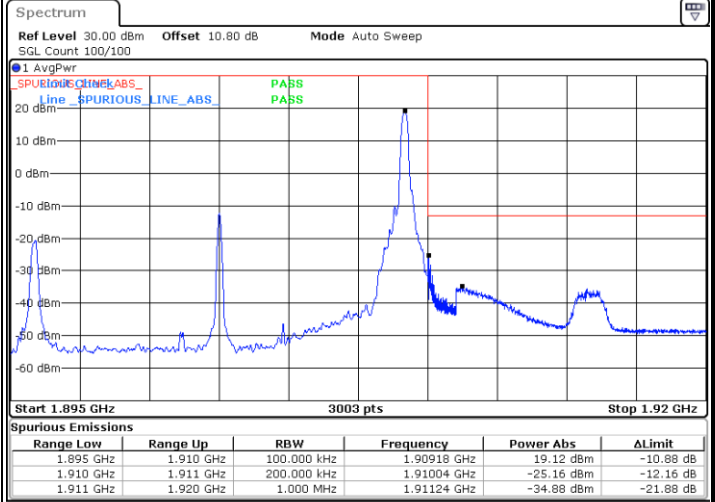

Date: 12.OCT.2021 11:03:58

Lowest Band Edge / Full RB

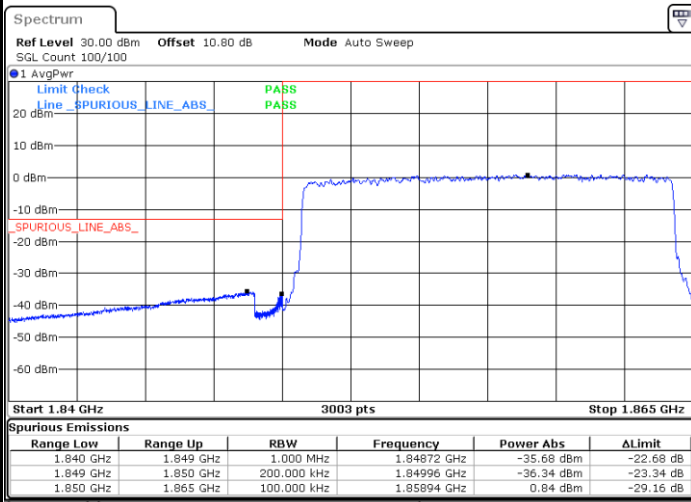

Date: 12.OCT.2021 11:02:25

Highest Band Edge / Full RB

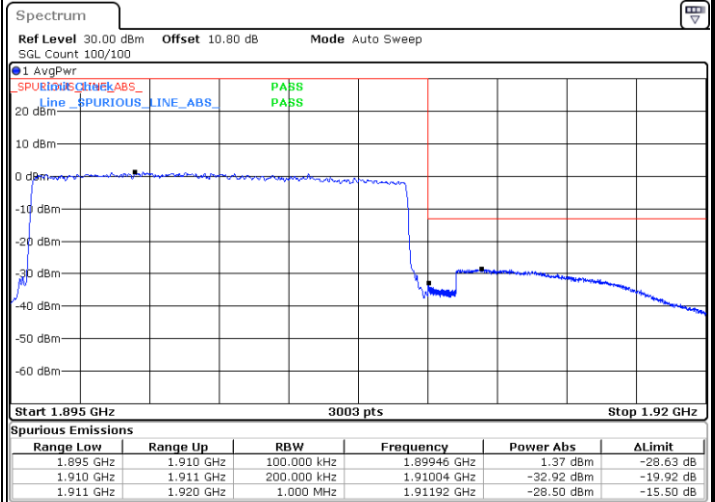

Date: 12.OCT.2021 11:04:48



LTE Band 2 / 20MHz / 16QAM

Lowest Band Edge / 1 RB

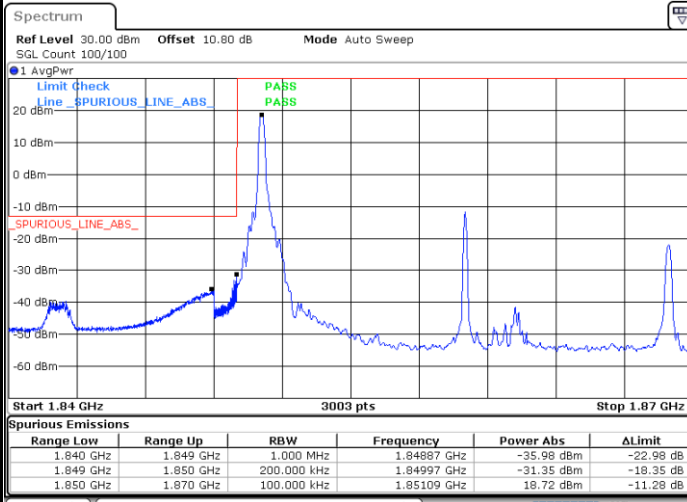

Date: 12.OCT.2021 11:05:40

Highest Band Edge / 1 RB

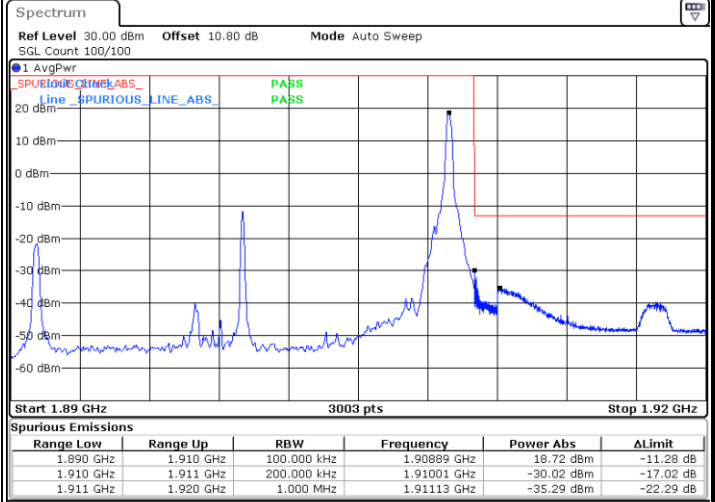

Date: 12.OCT.2021 11:08:03

Lowest Band Edge / Full RB

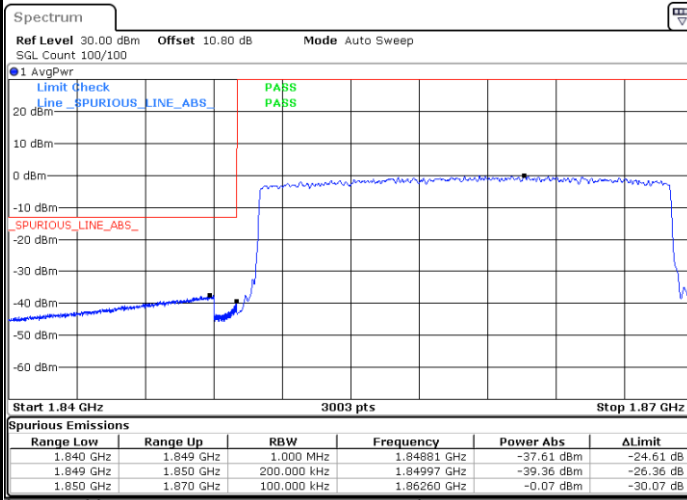

Date: 12.OCT.2021 11:06:30

Highest Band Edge / Full RB

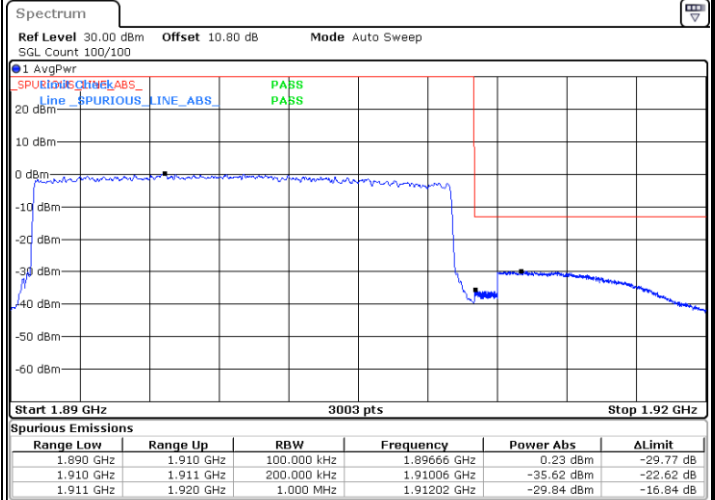

Date: 12.OCT.2021 11:08:54



### Frequency Stability

Test Conditions		LTE Band 2 (16QAM) / Middle Channel	Limit
Temperature (°C)	Voltage (Volt)	BW 10MHz	Note 2.
		Deviation (ppm)	Result
50	Normal Voltage	0.0028	PASS
40	Normal Voltage	0.0008	
30	Normal Voltage	0.0005	
20(Ref.)	Normal Voltage	0.0000	
10	Normal Voltage	0.0007	
0	Normal Voltage	0.0013	
-10	Normal Voltage	0.0031	
-20	Normal Voltage	0.0014	
-30	Normal Voltage	0.0019	
20	Maximum Voltage	0.0019	
20	Normal Voltage	0.0000	
20	Battery End Point	0.0016	

**Note:**

1. Normal Voltage =14 V. ; Battery End Point (BEP) =12 V. ; Maximum Voltage =16 V.
2. The frequency fundamental emissions stay within the authorized frequency block.



# LTE Band 4

## Peak-to-Average Ratio

Mode	LTE Band 4 / 20MHz				
Mod.	QPSK	16QAM	64QAM	256QAM	Limit: 13dB
RB Size	Full RB	Full RB	Full RB	Full RB	Result
Middle CH	-	6.61	-	-	PASS

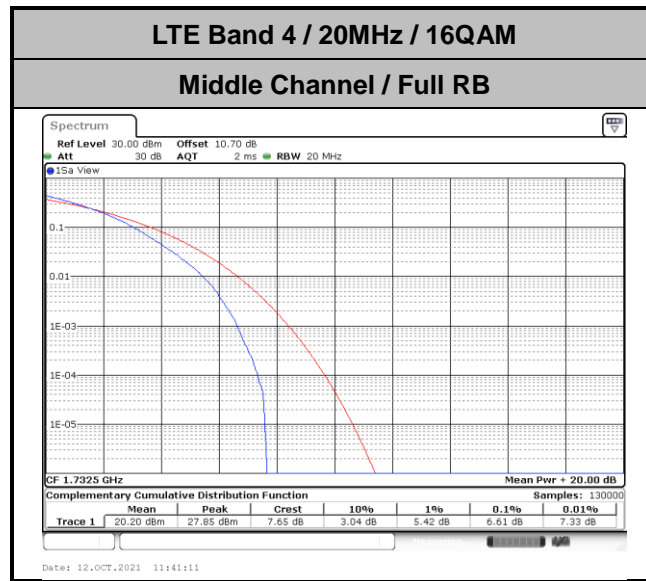



**26dB Bandwidth**

Mode	LTE Band 4 : 26dB BW(MHz)											
	1.4MHz		3MHz		5MHz		10MHz		15MHz		20MHz	
BW												
Mod.	QPSK	16QAM	QPSK	16QAM	QPSK	16QAM	QPSK	16QAM	QPSK	16QAM	QPSK	16QAM
Middle CH	-	1.27	-	3.04	-	4.98	-	9.85	-	14.45	-	19.06



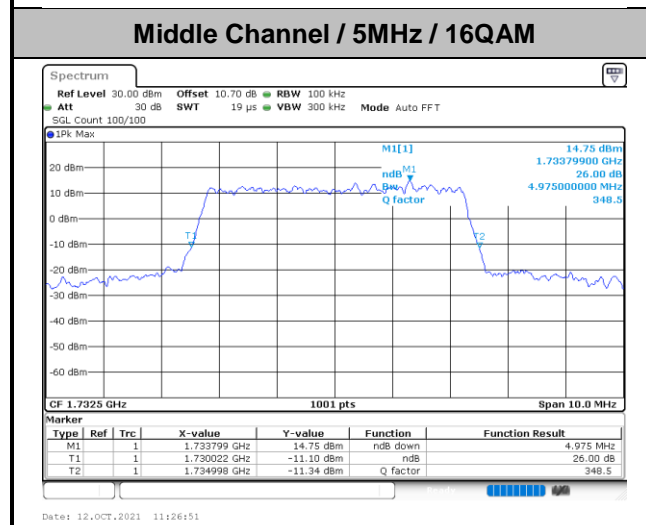
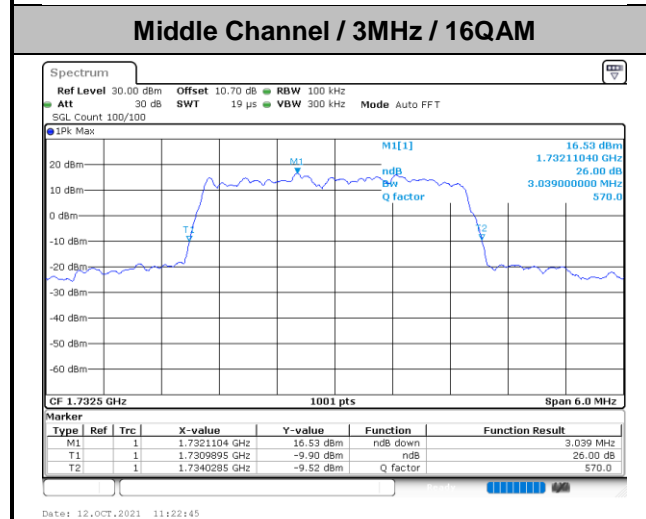
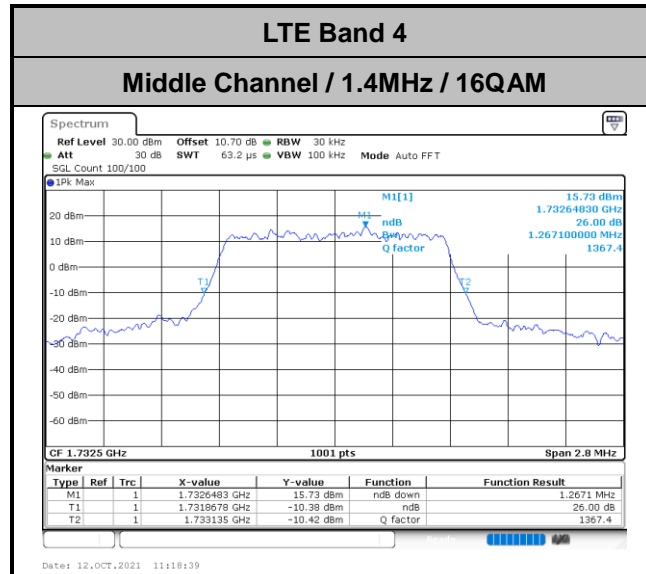

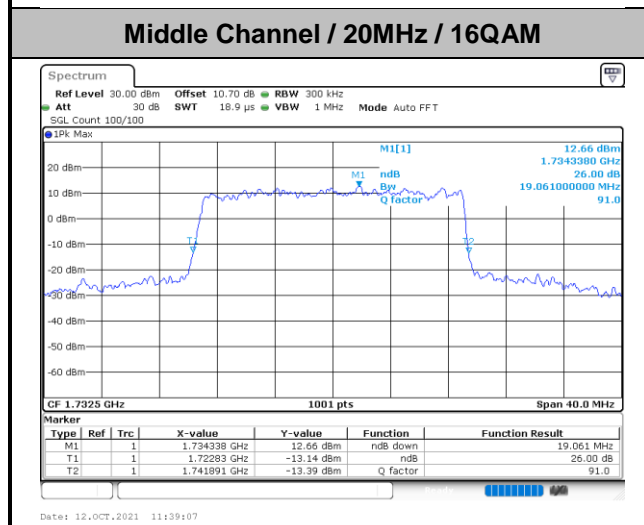
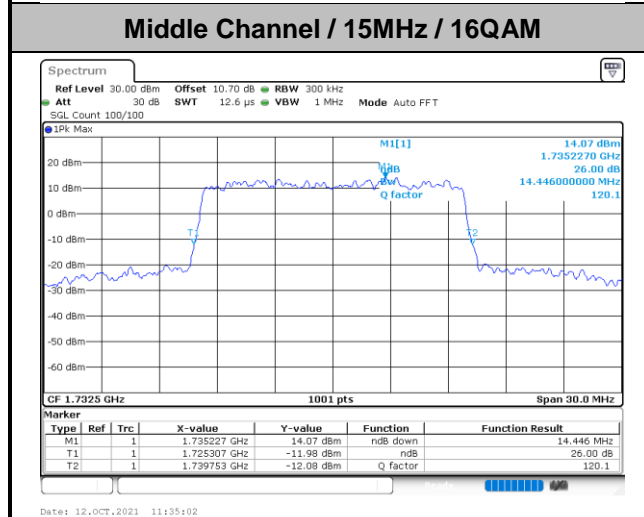
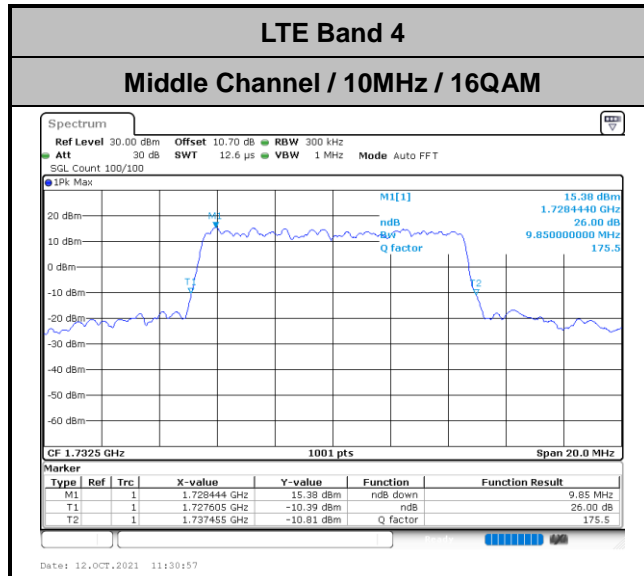



**Occupied Bandwidth**

Mode	LTE Band 4 : 99%OBW(MHz)											
	1.4MHz		3MHz		5MHz		10MHz		15MHz		20MHz	
BW												
Mod.	QPSK	16QAM	QPSK	16QAM	QPSK	16QAM	QPSK	16QAM	QPSK	16QAM	QPSK	16QAM
Middle CH	-	1.09	-	2.72	-	4.50	-	8.97	-	13.37	-	17.82

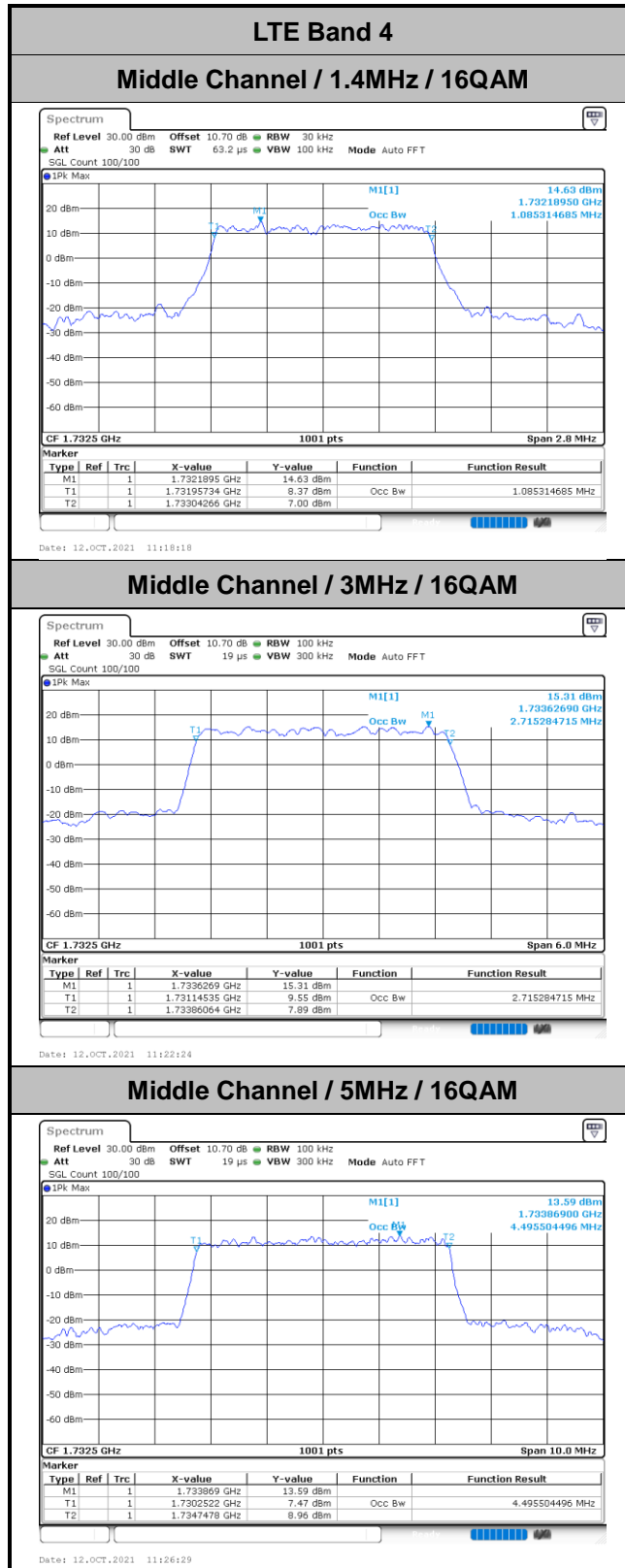

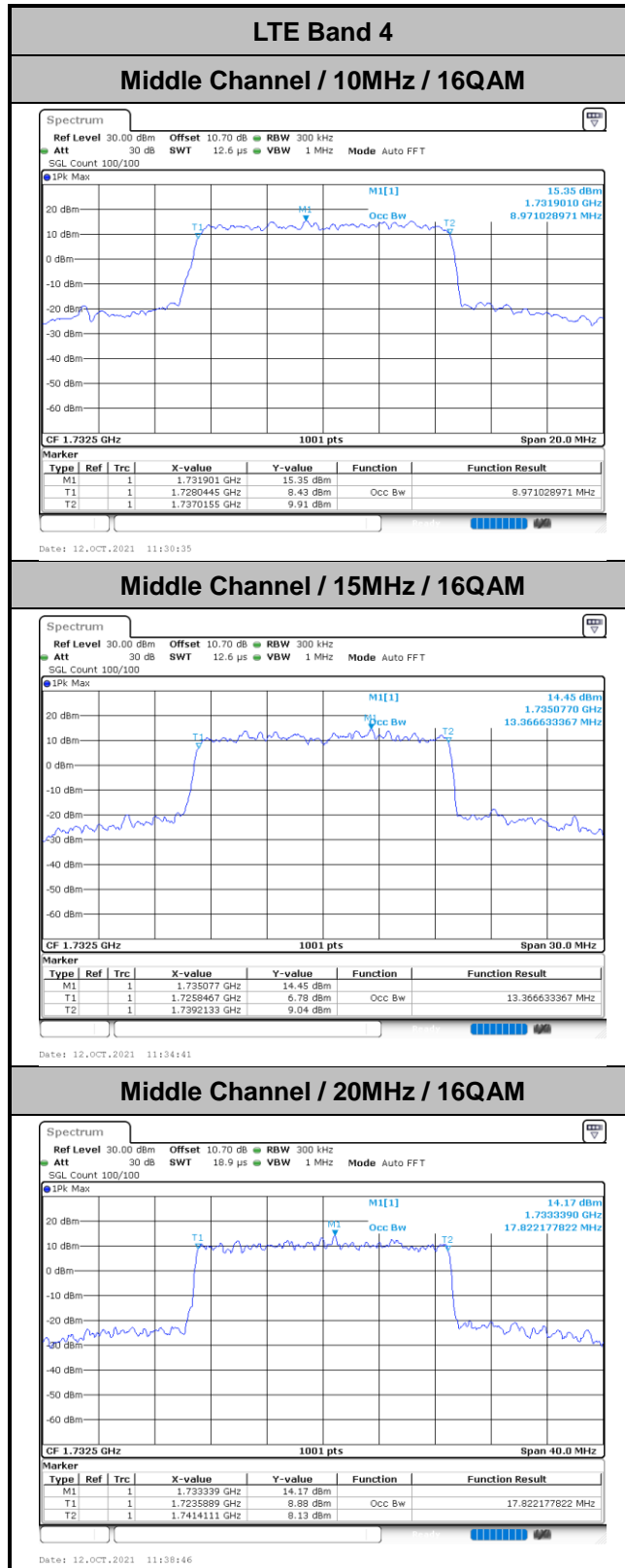



# Conducted Band Edge

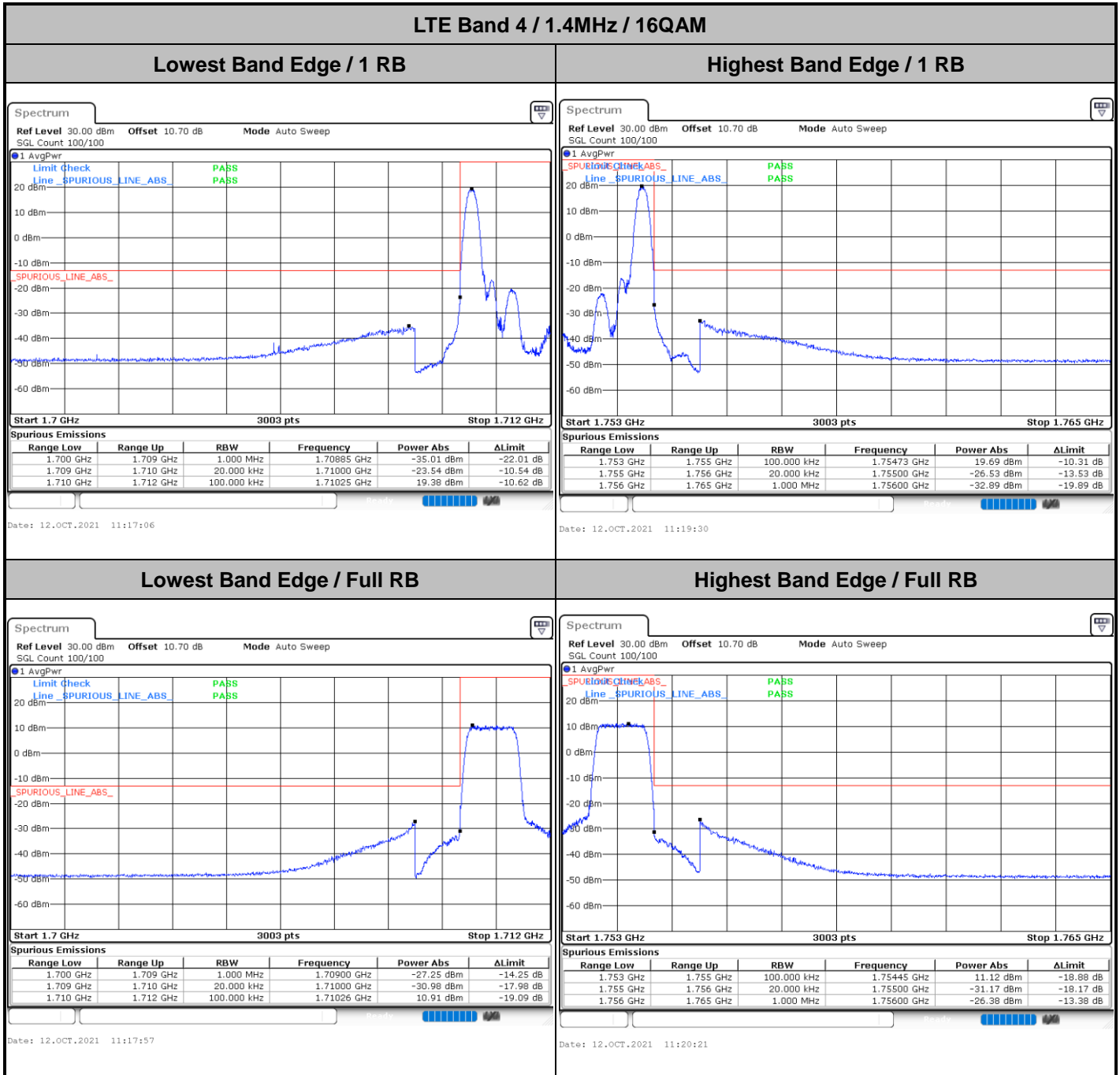



LTE Band 4 / 3MHz / 16QAM

Lowest Band Edge / 1 RB

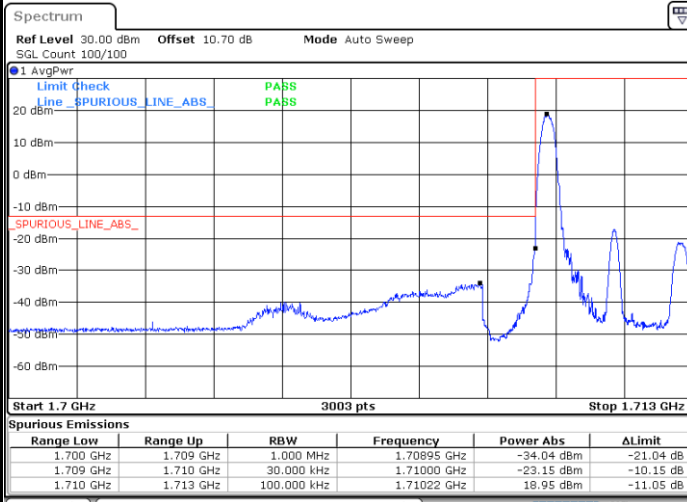

Date: 12.OCT.2021 11:21:12

Highest Band Edge / 1 RB

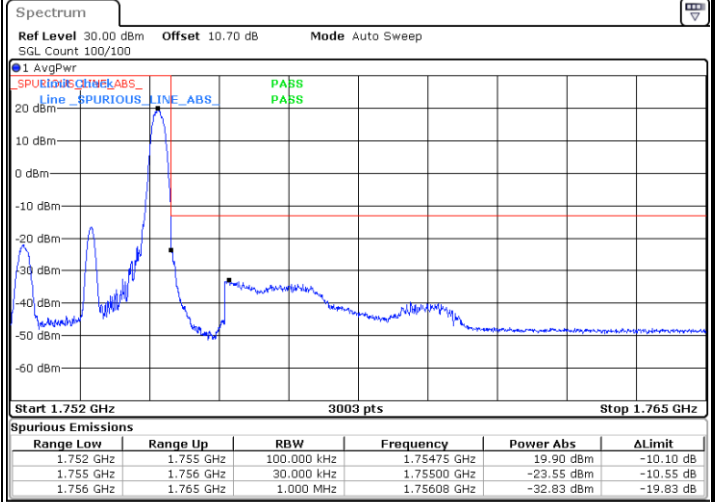

Date: 12.OCT.2021 11:23:36

Lowest Band Edge / Full RB

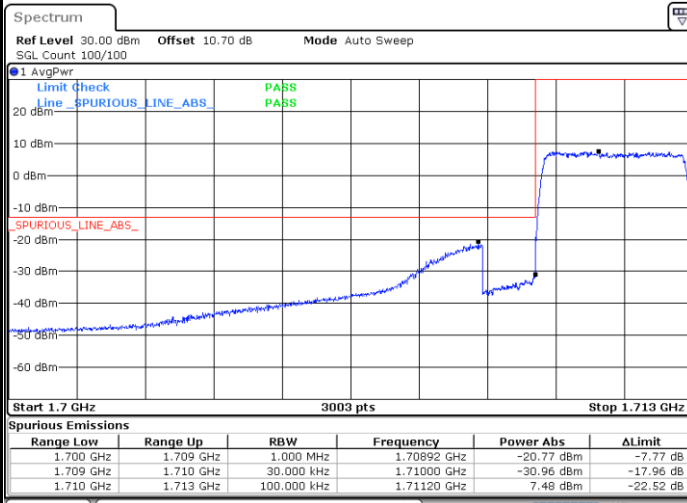

Date: 12.OCT.2021 11:22:03

Highest Band Edge / Full RB

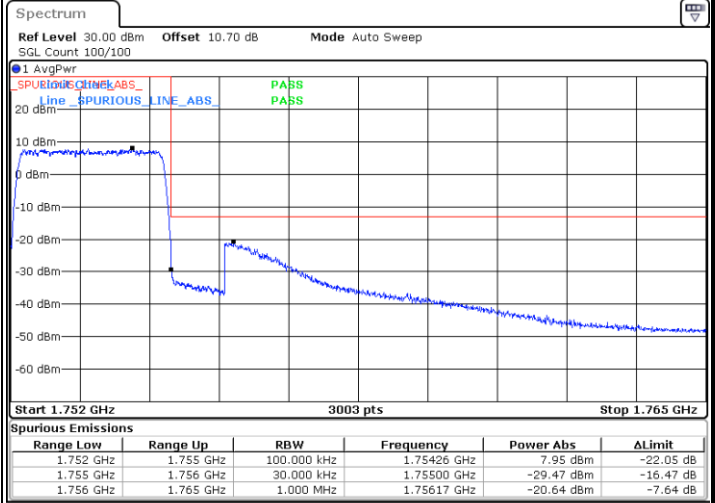

Date: 12.OCT.2021 11:24:26



LTE Band 4 / 5MHz / 16QAM

Lowest Band Edge / 1RB

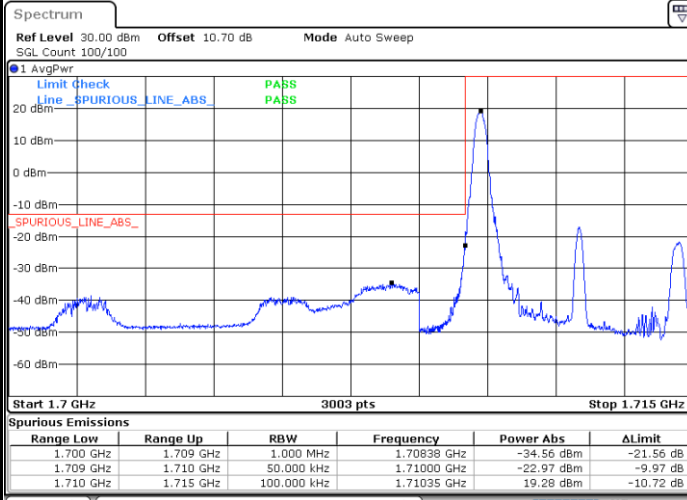

Date: 12.OCT.2021 11:25:18

Highest Band Edge / 1 RB

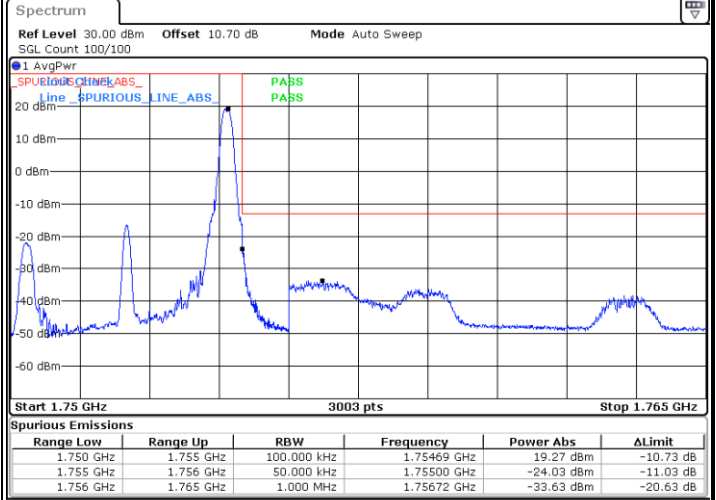

Date: 12.OCT.2021 11:27:41

Lowest Band Edge / Full RB

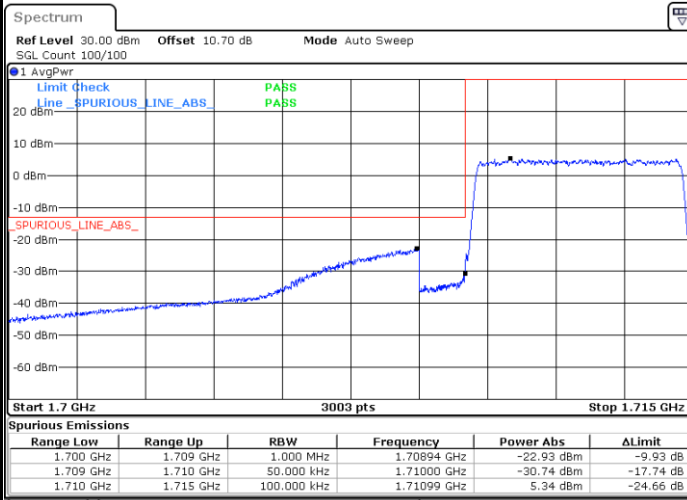

Date: 12.OCT.2021 11:26:08

Highest Band Edge / Full RB

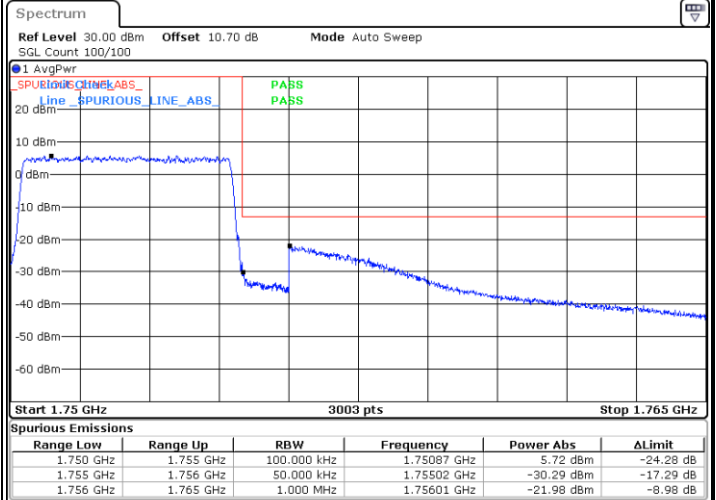

Date: 12.OCT.2021 11:28:32





LTE Band 4 / 10MHz / 16QAM

Lowest Band Edge / 1 RB

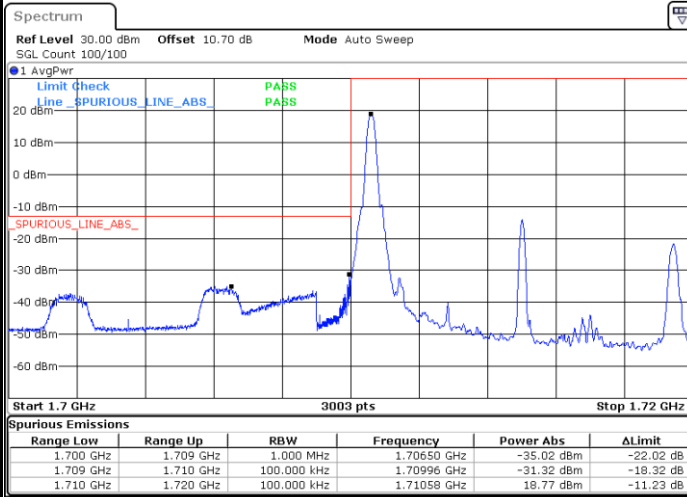

Date: 12.OCT.2021 11:29:23

Highest Band Edge / 1 RB

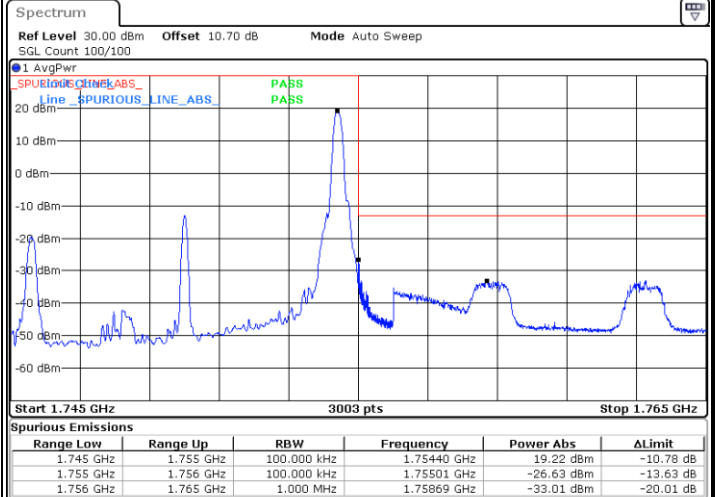

Date: 12.OCT.2021 11:31:47

Lowest Band Edge / Full RB

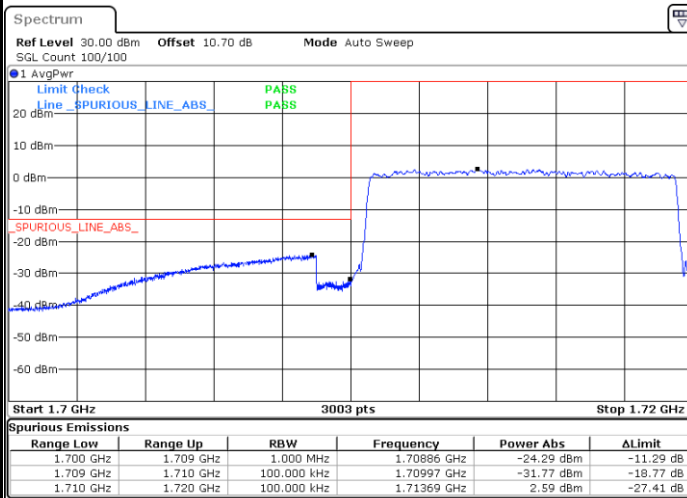

Date: 12.OCT.2021 11:30:14

Highest Band Edge / Full RB

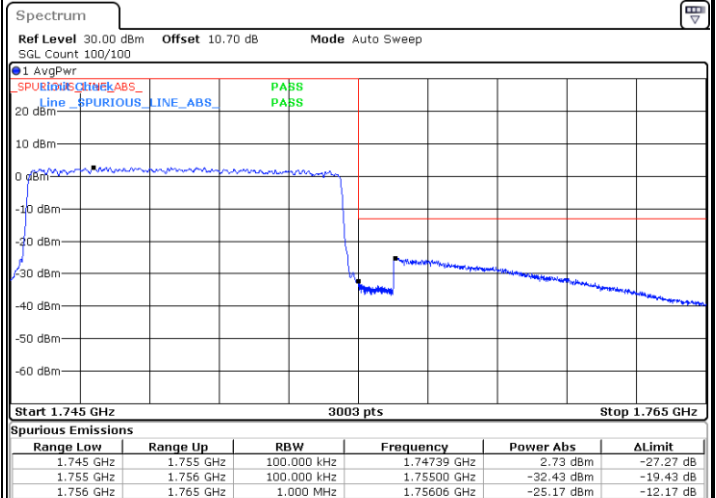

Date: 12.OCT.2021 11:32:38



LTE Band 4 / 15MHz / 16QAM

Lowest Band Edge / 1 RB

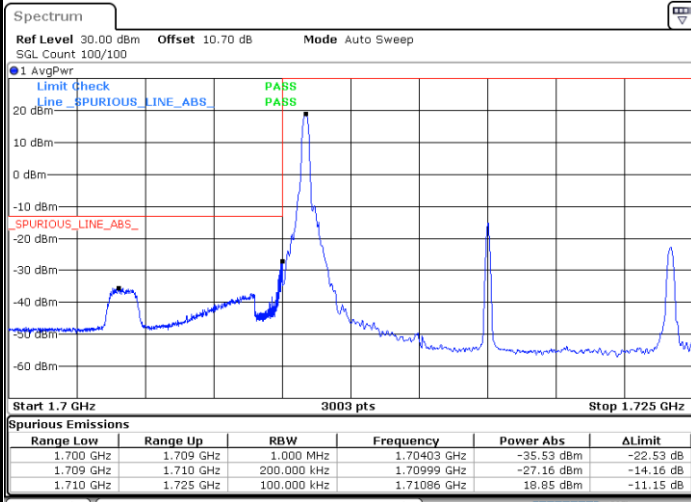

Date: 12.OCT.2021 11:33:29

Highest Band Edge / 1 RB

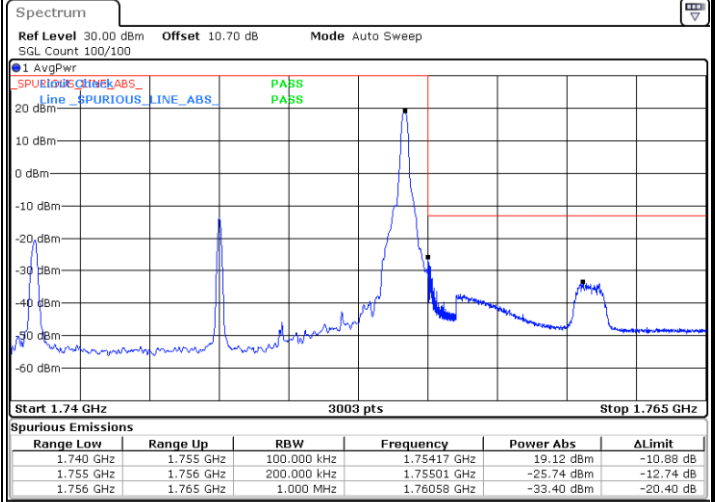

Date: 12.OCT.2021 11:35:52

Lowest Band Edge / Full RB

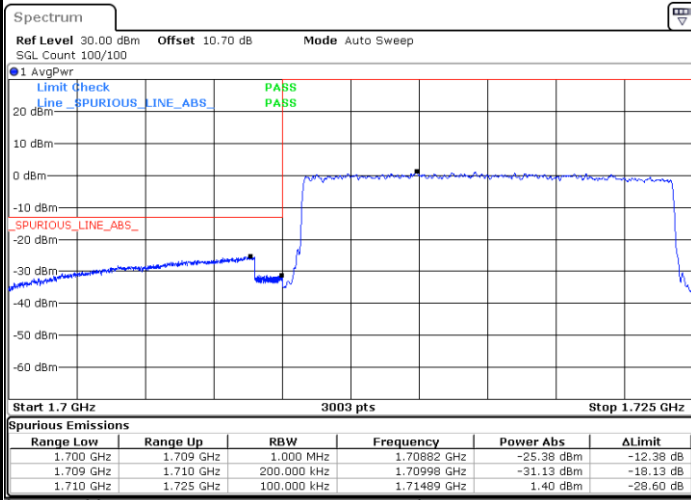

Date: 12.OCT.2021 11:34:20

Highest Band Edge / Full RB

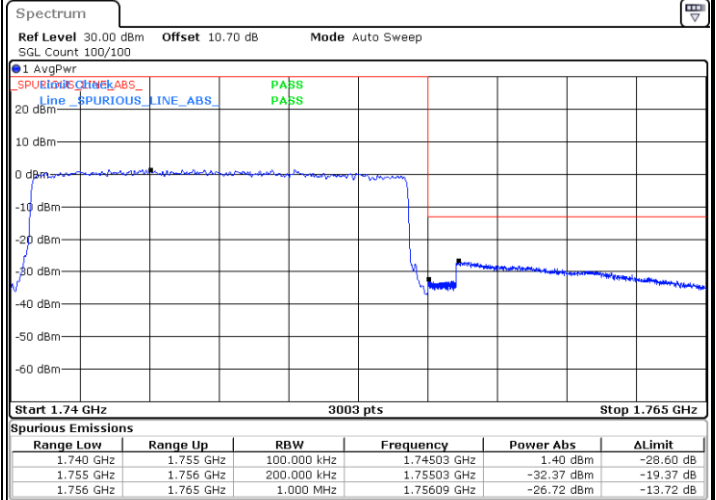

Date: 12.OCT.2021 11:36:43



LTE Band 4 / 20MHz / 16QAM

Lowest Band Edge / 1 RB

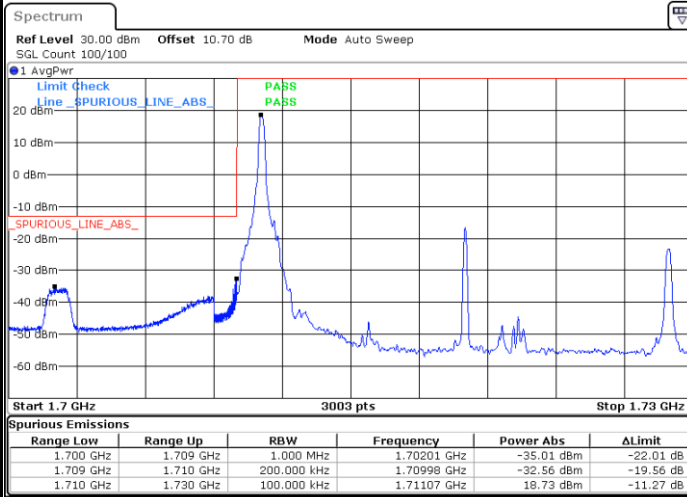

Date: 12.OCT.2021 11:37:34

Highest Band Edge / 1 RB

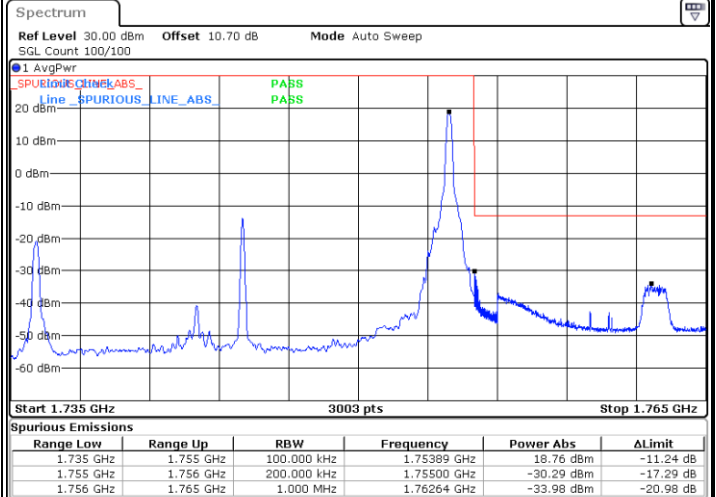

Date: 12.OCT.2021 11:39:58

Lowest Band Edge / Full RB

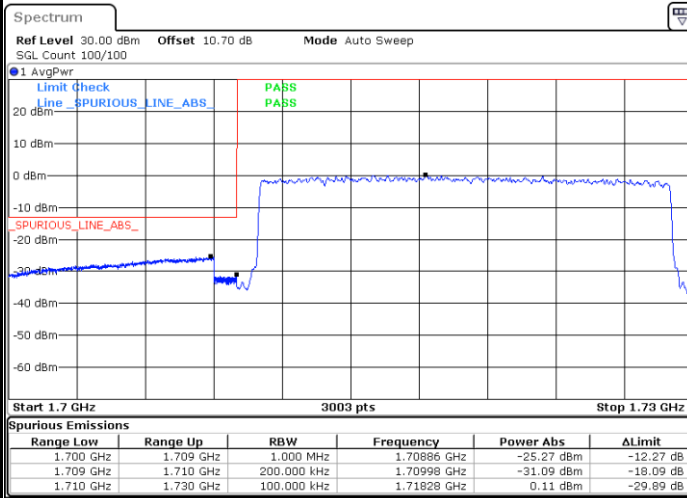

Date: 12.OCT.2021 11:38:25

Highest Band Edge / Full RB

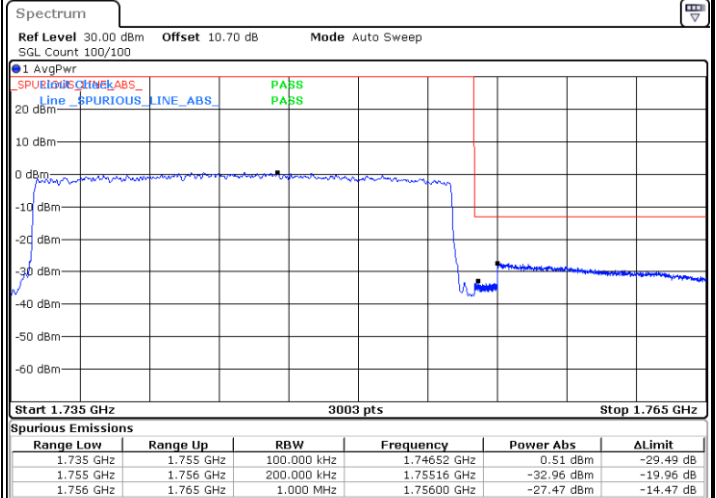

Date: 12.OCT.2021 11:40:49



### Frequency Stability

Test Conditions		LTE Band 4 (16QAM) / Middle Channel	Limit
Temperature (°C)	Voltage (Volt)	BW 10MHz	Note 2.
		Deviation (ppm)	Result
50	Normal Voltage	0.0020	PASS
40	Normal Voltage	0.0003	
30	Normal Voltage	0.0012	
20(Ref.)	Normal Voltage	0.0000	
10	Normal Voltage	0.0017	
0	Normal Voltage	0.0030	
-10	Normal Voltage	0.0003	
-20	Normal Voltage	0.0001	
-30	Normal Voltage	0.0017	
20	Maximum Voltage	0.0021	
20	Normal Voltage	0.0000	
20	Battery End Point	0.0012	

**Note:**

- 1. Normal Voltage =14 V. ; Battery End Point (BEP) =12 V. ; Maximum Voltage =16 V.
- 2. The frequency fundamental emissions stay within the authorized frequency block.



# LTE Band 5

## Peak-to-Average Ratio

Mode	LTE Band 5 / 10MHz				
Mod.	QPSK	16QAM	64QAM	256QAM	Limit: 13dB
RB Size	Full RB	Full RB	Full RB	Full RB	Result
Middle CH	-	5.97	-	-	PASS

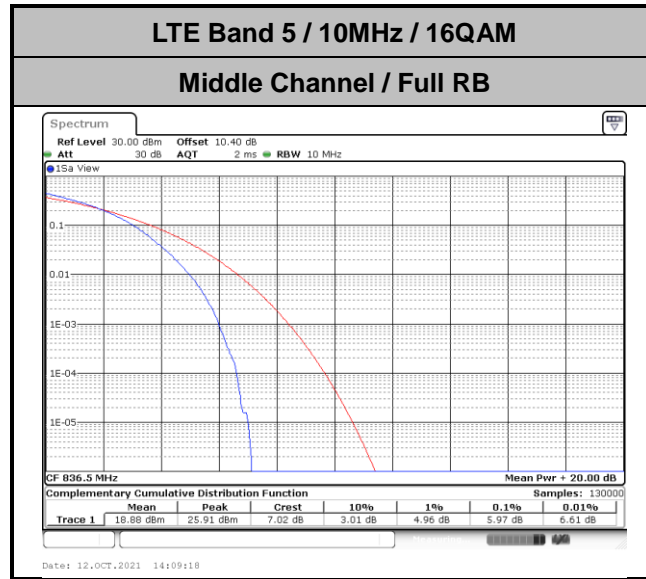



## 26dB Bandwidth

Mode	LTE Band 5 : 26dB BW(MHz)											
	1.4MHz		3MHz		5MHz		10MHz		15MHz		20MHz	
Mod.	QPSK	16QAM	QPSK	16QAM	QPSK	16QAM	QPSK	16QAM	QPSK	16QAM	QPSK	16QAM
Middle CH	-	1.28	-	3.02	-	4.92	-	9.89	-	-	-	-

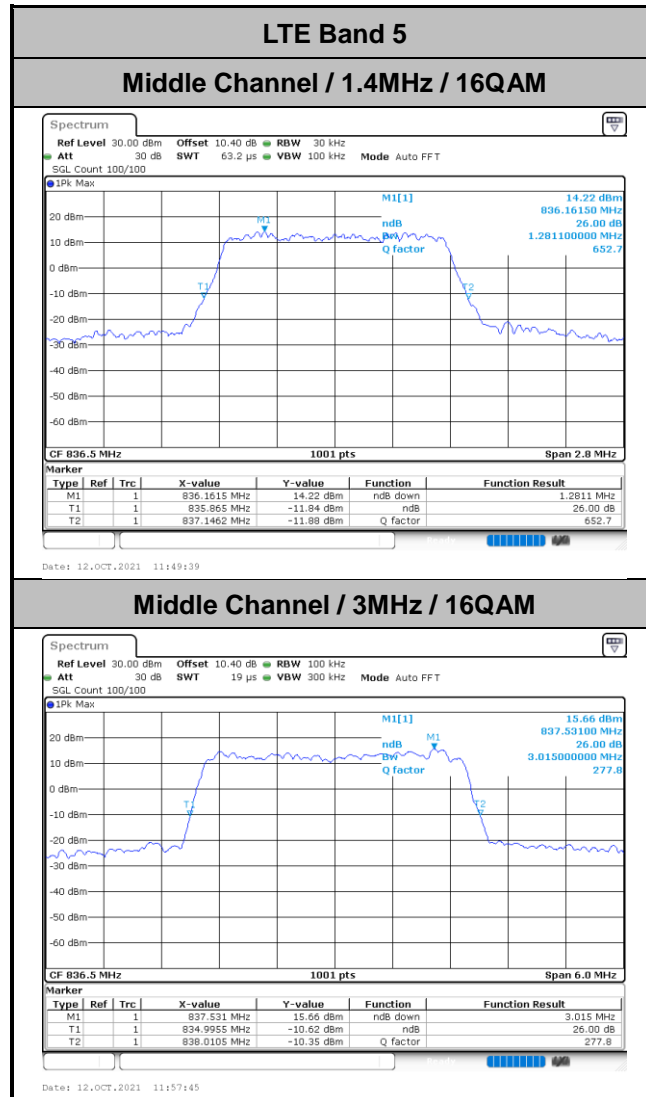

### Middle Channel / 3MHz / 16QAM

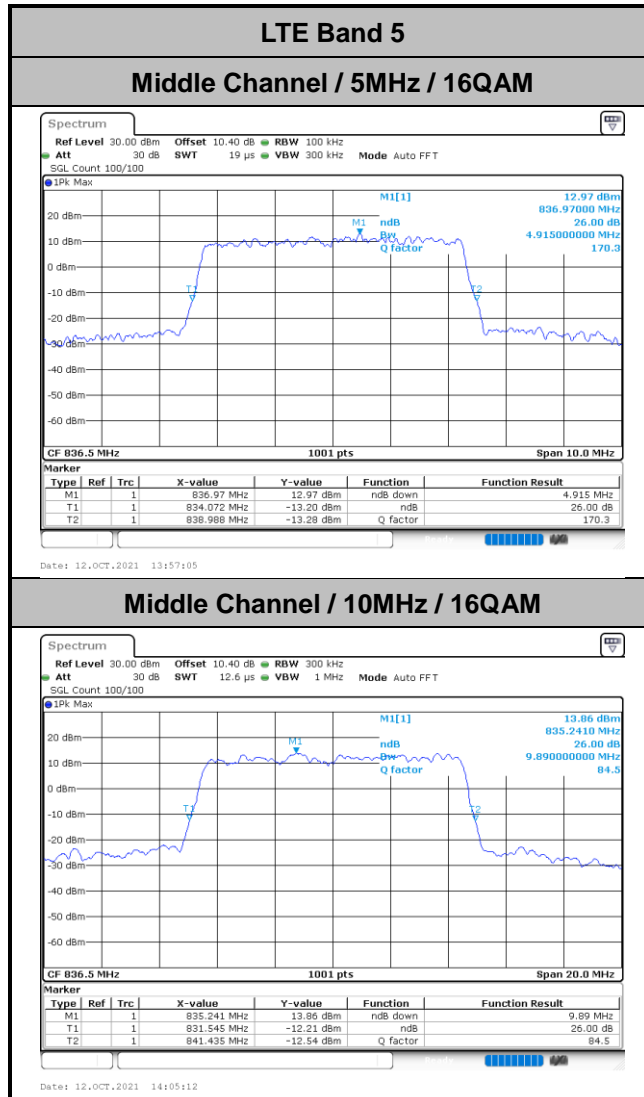



# Occupied Bandwidth

Mode	LTE Band 5 : 99%OBW(MHz)											
BW	1.4MHz		3MHz		5MHz		10MHz		15MHz		20MHz	
Mod.	QPSK	16QAM	QPSK	16QAM	QPSK	16QAM	QPSK	16QAM	QPSK	16QAM	QPSK	16QAM
Middle CH	-	1.09	-	2.70	-	4.49	-	9.01	-	-	-	-

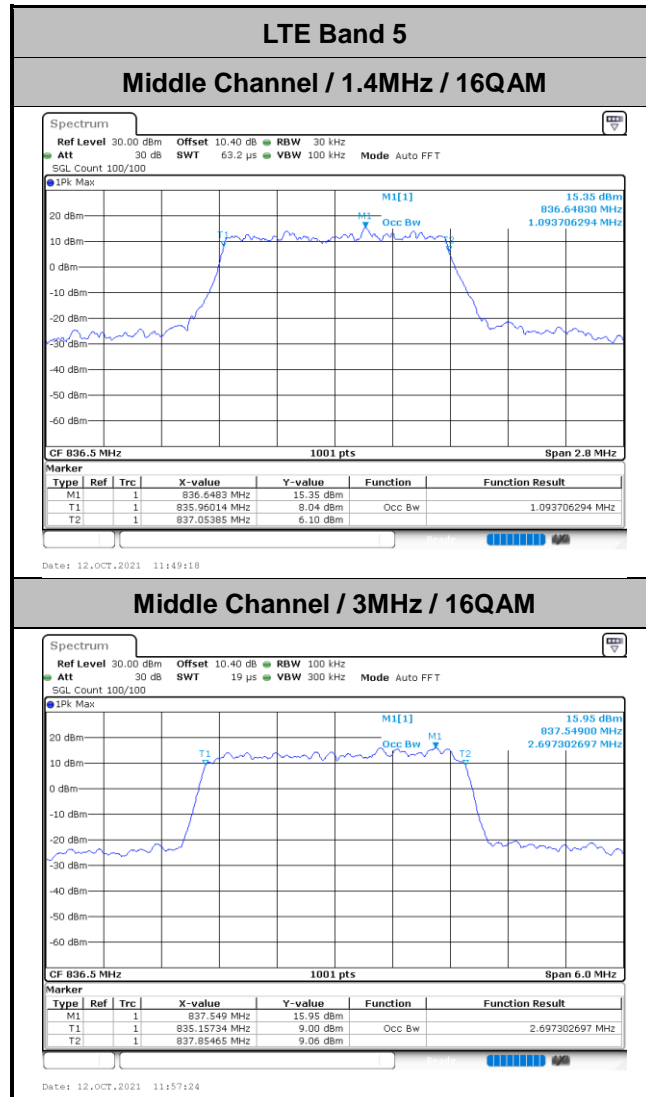



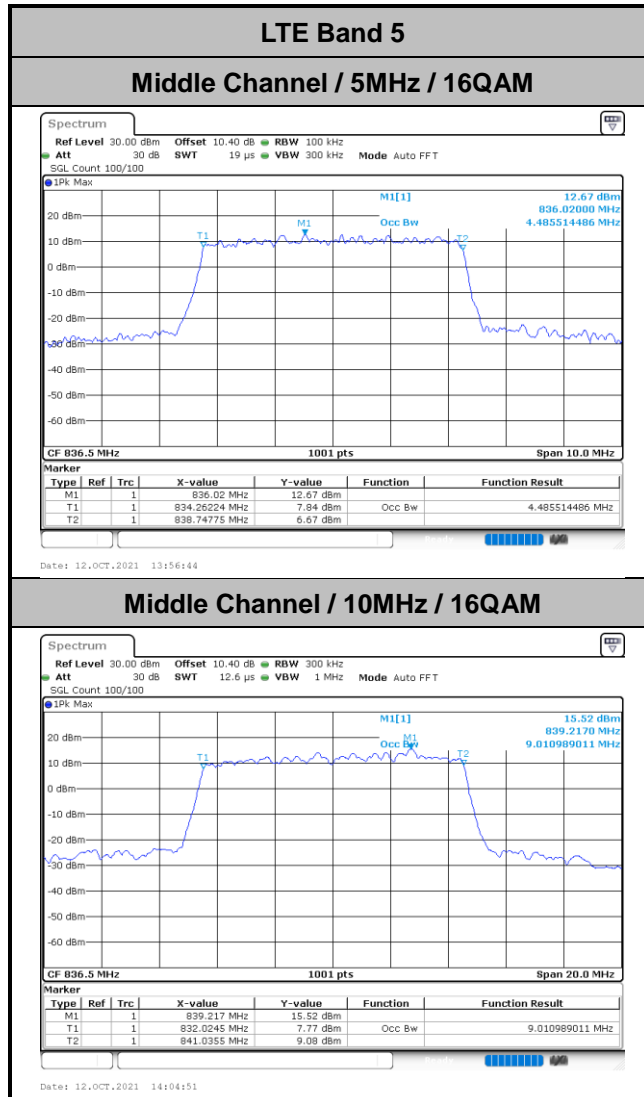



# Conducted Band Edge

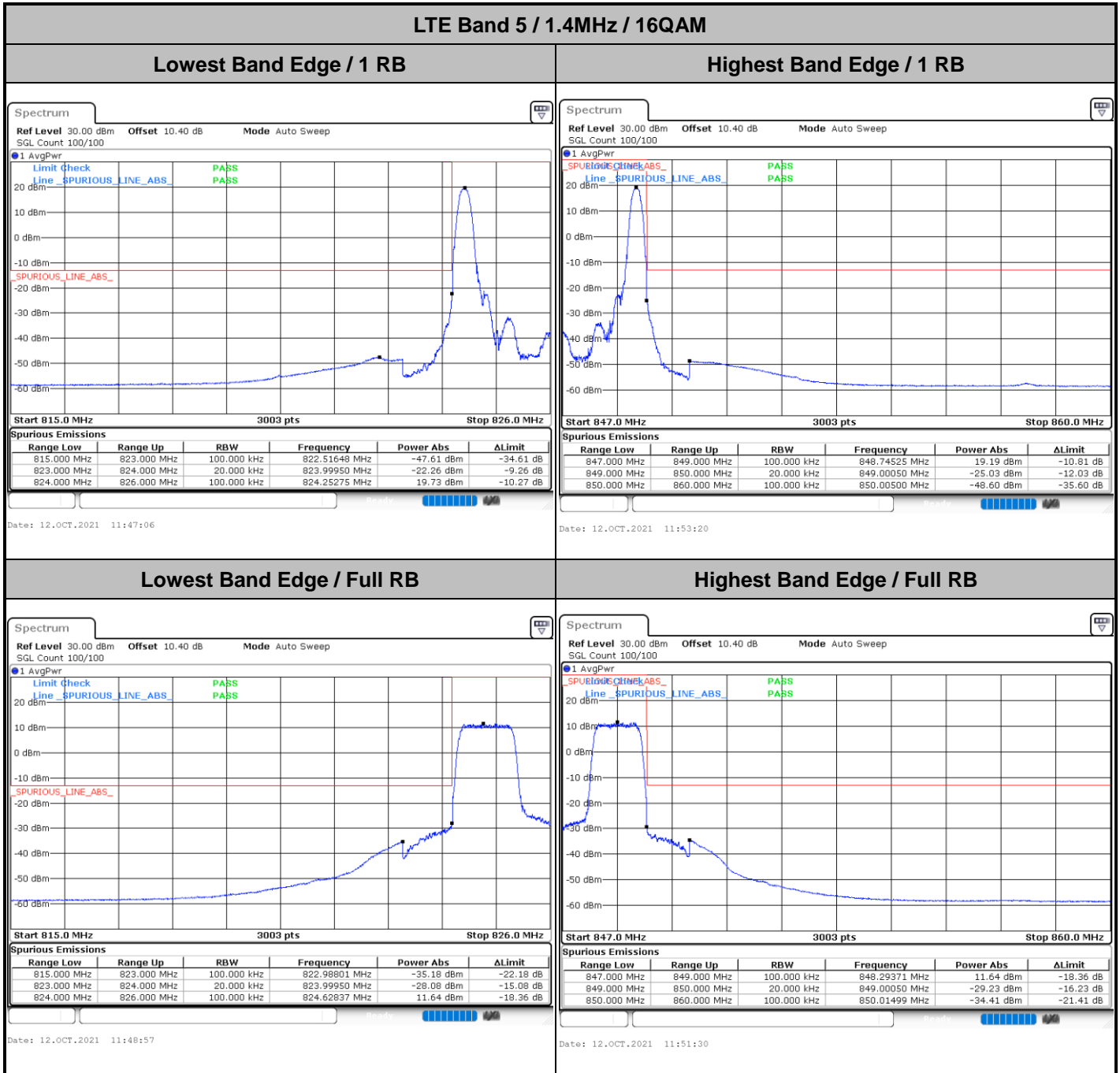



LTE Band 5 / 3MHz / 16QAM

Lowest Band Edge / 1 RB

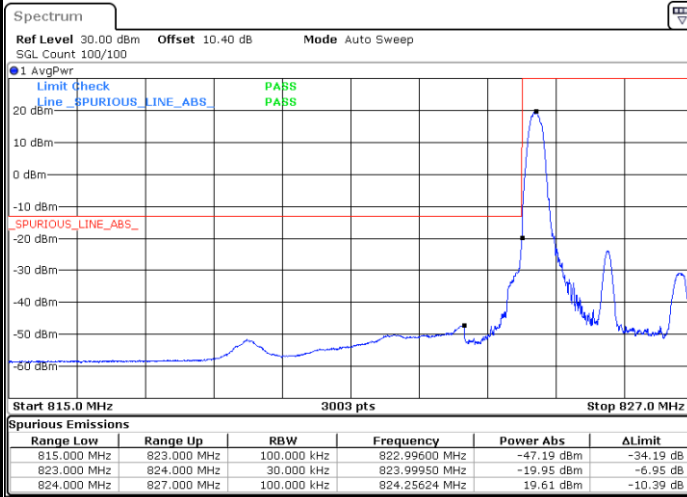

Date: 12.OCT.2021 11:55:12

Highest Band Edge / 1 RB

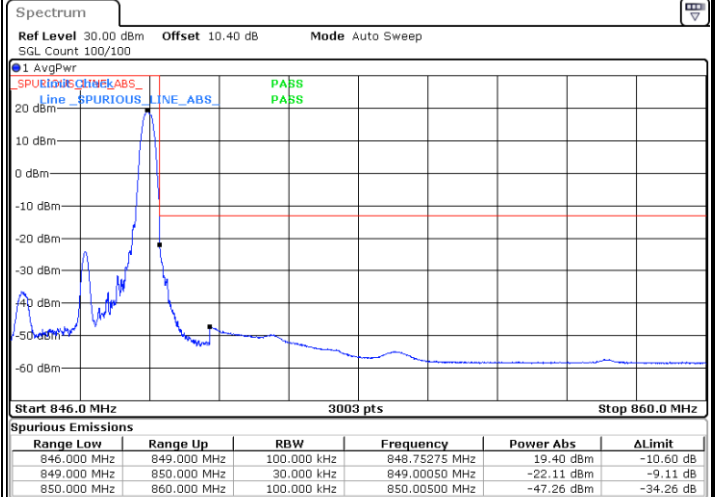

Date: 12.OCT.2021 11:59:36

Lowest Band Edge / Full RB

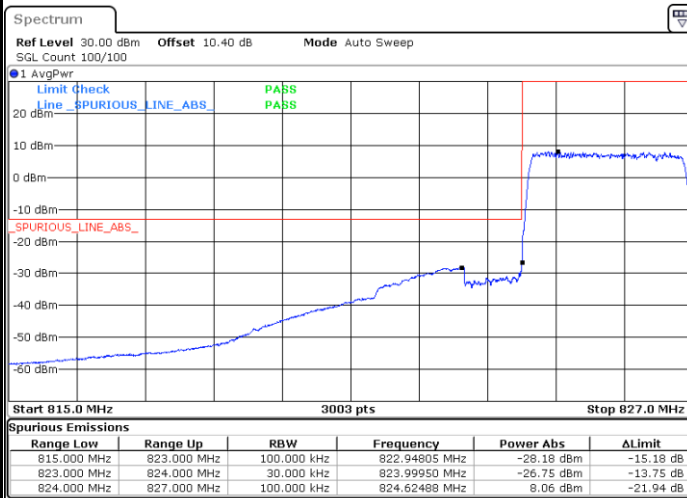

Date: 12.OCT.2021 11:57:03

Highest Band Edge / Full RB



Date: 12.OCT.2021 12:01:27



LTE Band 5 / 5MHz / 16QAM

Lowest Band Edge / 1RB

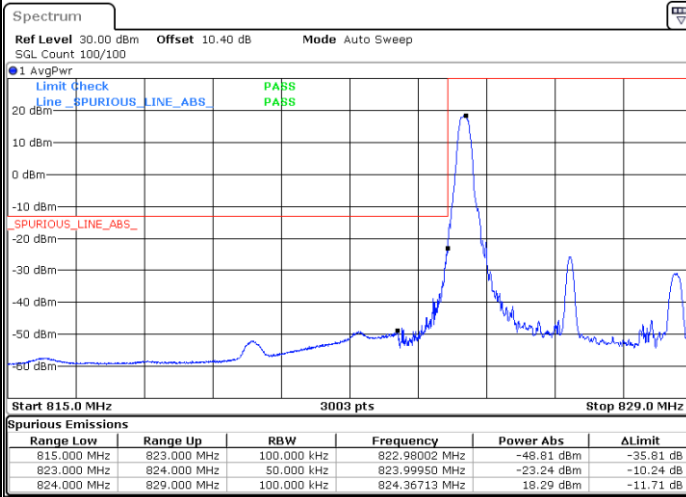

Date: 12.OCT.2021 13:54:31

Highest Band Edge / 1 RB

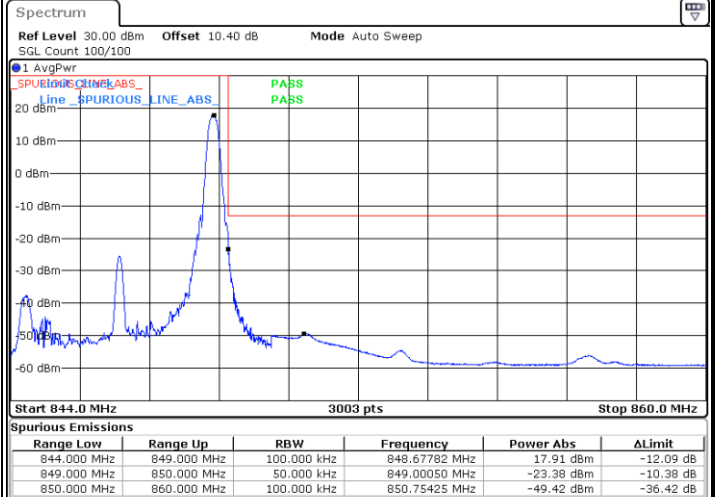

Date: 12.OCT.2021 13:58:56

Lowest Band Edge / Full RB

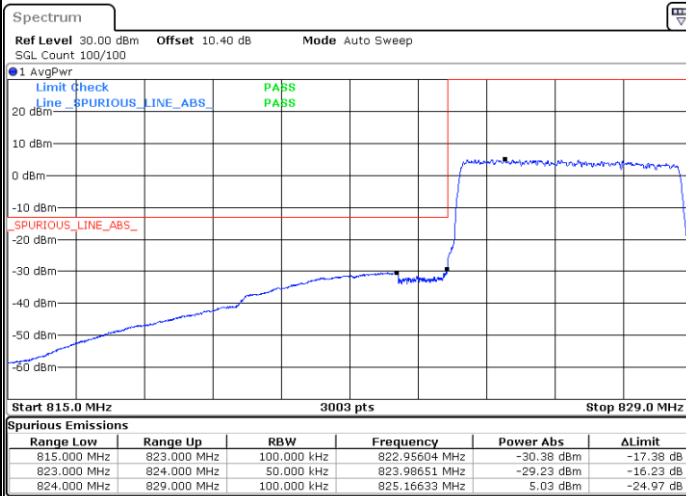

Date: 12.OCT.2021 13:56:22

Highest Band Edge / Full RB

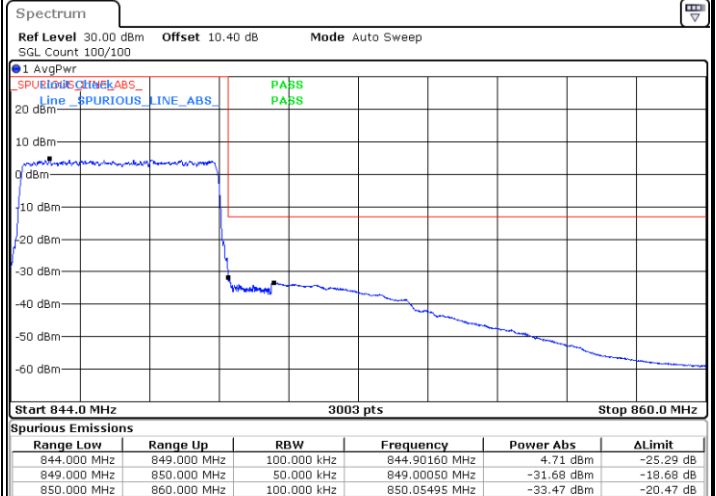

Date: 12.OCT.2021 14:00:48



LTE Band 5 / 10MHz / 16QAM

Lowest Band Edge / 1 RB

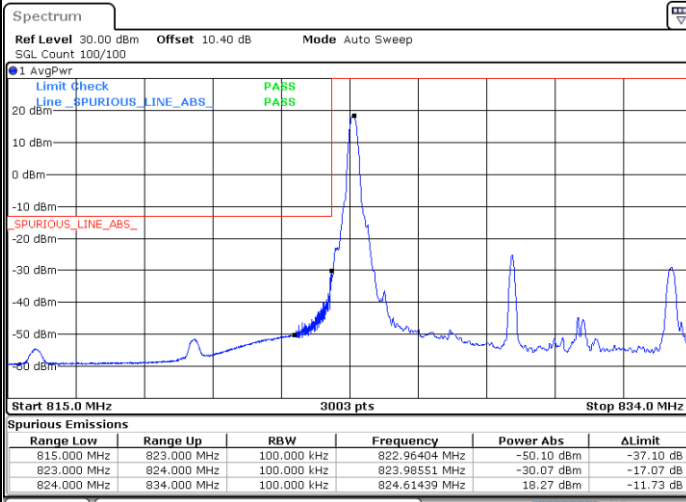

Date: 12.OCT.2021 14:02:39

Highest Band Edge / 1 RB

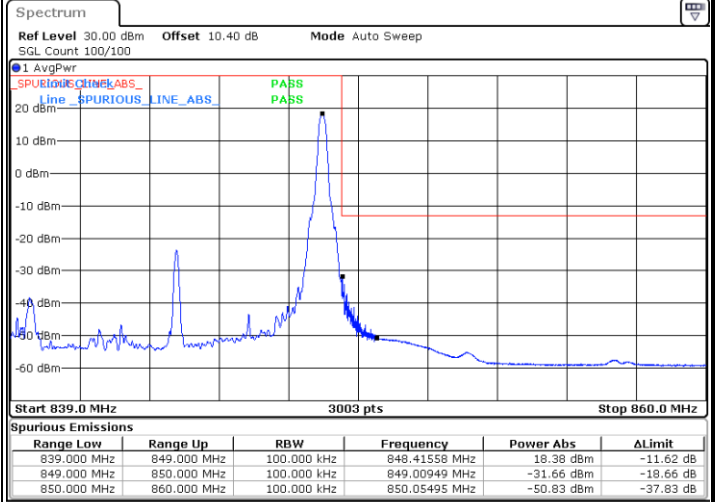

Date: 12.OCT.2021 14:07:03

Lowest Band Edge / Full RB

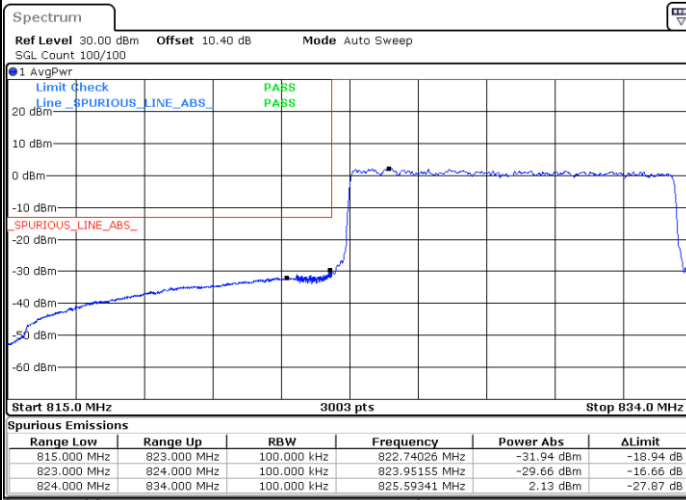

Date: 12.OCT.2021 14:04:30

Highest Band Edge / Full RB

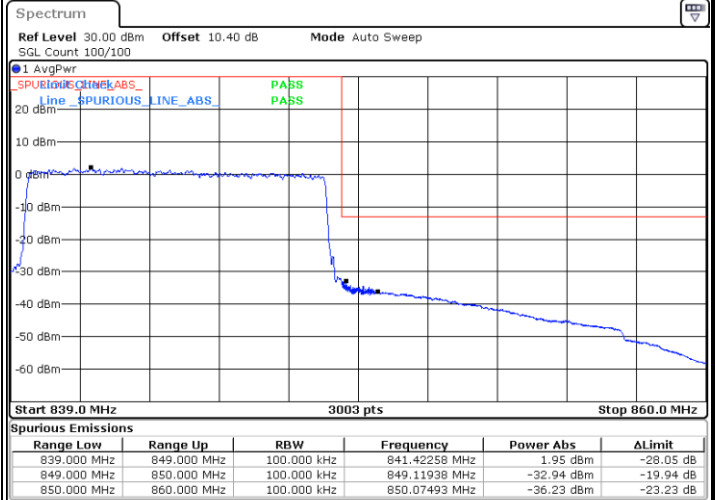

Date: 12.OCT.2021 14:08:54



### Frequency Stability

Test Conditions		LTE Band 5 (16QAM) / Middle Channel	Limit
Temperature (°C)	Voltage (Volt)	BW 10MHz	Note 2.
		Deviation (ppm)	Result
50	Normal Voltage	0.0019	PASS
40	Normal Voltage	0.0019	
30	Normal Voltage	0.0002	
20(Ref.)	Normal Voltage	0.0000	
10	Normal Voltage	0.0045	
0	Normal Voltage	0.0036	
-10	Normal Voltage	0.0024	
-20	Normal Voltage	0.0017	
-30	Normal Voltage	0.0010	
20	Maximum Voltage	0.0013	
20	Normal Voltage	0.0000	
20	Battery End Point	0.0001	

**Note:**

- 1. Normal Voltage =14 V. ; Battery End Point (BEP) =12 V. ; Maximum Voltage =16 V.
- 2. The frequency fundamental emissions stay within the authorized frequency block.