

Block diagram

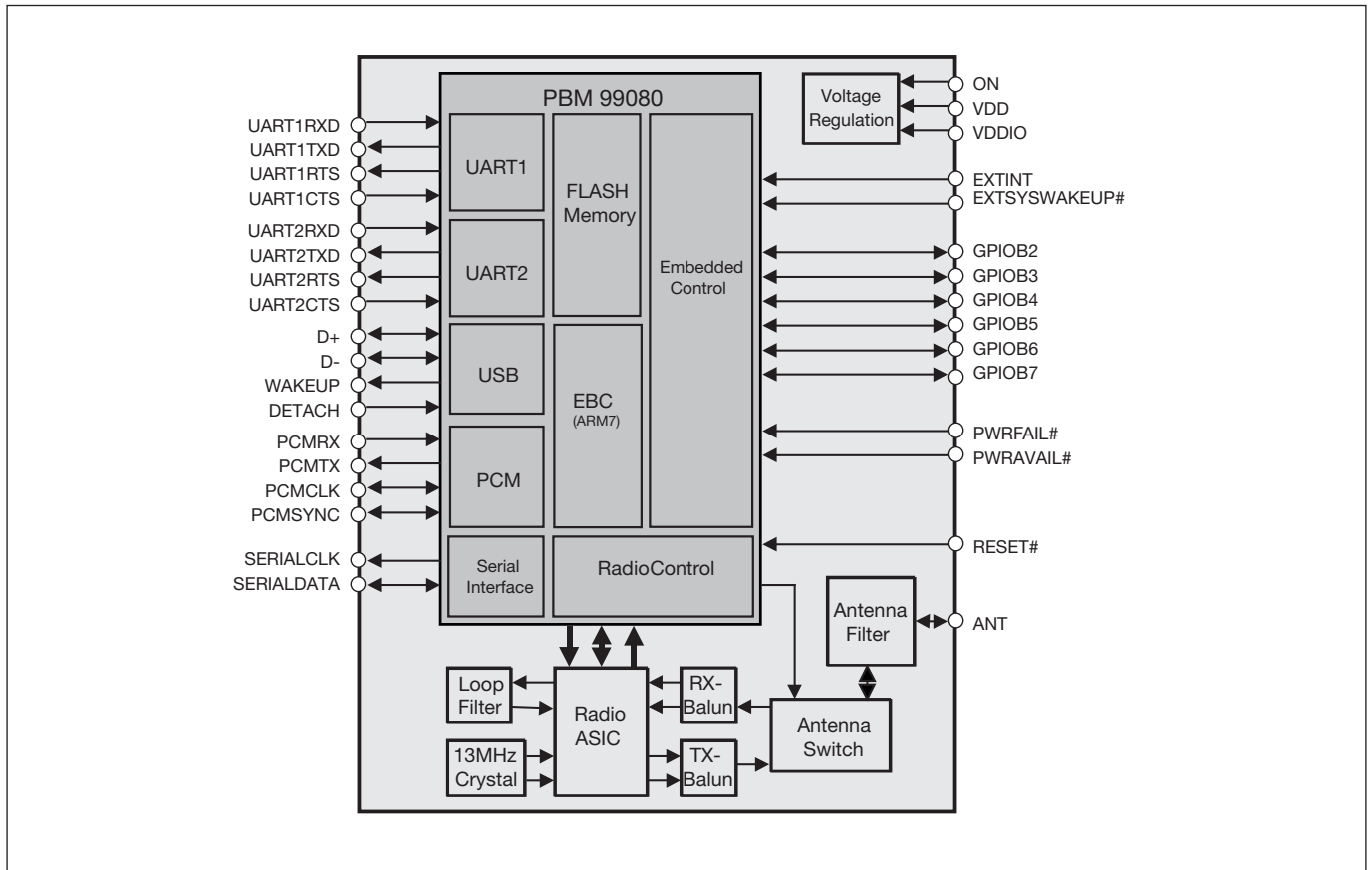

Figure 1. Block diagram.

Absolute maximum ratings

Parameter	Symbol	Min	Typ	Max	Unit
Temperature					
Storage temperature	T_{Stg}	-40		+100	°C
Operating temperature	T_{Amb}	-20		+75	°C
Power supply					
V_{DD} with respect to GND	V_{DD}	-0.3		6.5	V
V_{DD_IO} with respect to GND	V_{DD_IO}	-0.8		3.6	V
Digital inputs					
Input low voltage	V_{IL}	-0.5			V
Input high voltage	V_{IH}			$V_{DD_IO} + 0.3$	V
Antenna port					
Input RF power	In-band			15	dBm
	Out of band			15	dBm