



849 NW STATE ROAD 45
 NEWBERRY, FL 32669 USA
 PH: 888.472.2424 OR
 352.472.5500
 FAX: 352.472.2030
 EMAIL: INFO@TIMCOENGR.COM
[HTTP://WWW.TIMCOENGR.COM](http://WWW.TIMCOENGR.COM)

FCC PART 90/ RSS-119 VHF BASE STATION COMBO TEST REPORT

APPLICANT	UNIFICATION CO., LTD.
ADDRESS	5F, NO.6, WU-KUNG 5 RD. HSINCHUANG CITY, TAIPEI TAIWAN
FCC ID	LEA-R01VHF
IC #	3819A-R01VHF
MODEL NUMBER	R01VHFT
PRODUCT DESCRIPTION	VHF REPEATER - FIXED MOUNTED
DATE SAMPLE RECEIVED	7/29/2016
FINAL TEST DATE	8/3/2016
TESTED BY	Cory Leverett
APPROVED BY	Sid Sanders
TEST RESULTS	<input checked="" type="checkbox"/> PASS <input type="checkbox"/> FAIL

Report Number	Version Number	Description	Issue Date
438ZAUT16TestReport_	Rev1	Initial Issue	8/3/2016
438ZAUT16TestReport_	Rev2	Updates to Power Source	10/4/2016

THE ATTACHED REPORT SHALL NOT BE REPRODUCED EXCEPT IN FULL WITHOUT THE WRITTEN APPROVAL OF TIMCO ENGINEERING, INC.

Table of Contents

GENERAL REMARKS.....	3
GENERAL INFORMATION.....	4
TEST RESULTS SUMMARY.....	5
RF POWER OUTPUT.....	6
Test Data: Conducted Power Output Table.....	6
MODULATION CHARACTERISTICS.....	7
BANDWIDTH CALCUATION.....	7
AUDIO FREQUENCY RESPONSE – 12.5 kHz.....	8
AUDIO FREQUENCY RESPONSE – 25 kHz.....	9
AUDIO LOW PASS FILTER 12.5 kHz.....	10
AUDIO LOW PASS FILTER 25 kHz.....	11
MODULATION LIMITING 12.5 kHz.....	12
MODULATION LIMITING 25 kHz.....	13
OCCUPIED BANDWIDTH.....	14
TEST FREQ. 150.85 MHz–16k0F3E.....	15
TEST FREQ. 150.85 MHz–11k0F3E.....	16
TEST FREQ. 150.85 MHz–8K2F1E/8K2F1D.....	17
TEST FREQ. 150.85 MHz–7K8FXD/7K8FXW/7K8FXE.....	18
SPURIOUS EMISSIONS AT ANTENNA TERMINALS.....	19
TEST FREQ. 150.85 MHz.....	20
TEST FREQ. 161.00 MHz.....	21
TEST FREQ. 173.35 MHz.....	22
FIELD STRENGTH OF SPURIOUS RADIATION EMISSIONS.....	23
TEST FREQ. 150.85 MHz.....	24
TEST FREQ. 161.00 MHz.....	25
TEST FREQ. 173.35 MHz.....	25
FREQUENCY STABILITY.....	26
Test Data: 173.35 MHz 11K0F3E.....	26
TRANSIENT FREQUENCY RESPONSE.....	27
Test Data: 12.5 KHz Channel Spacing Turn On.....	29
Test Data: 12.5 KHz Channel Spacing Turn Off.....	30
Test Data: 25 KHz Channel Spacing Turn On.....	31
Test Data: 25 KHz Channel Spacing Turn Off.....	32
EQUIPMENT LIST.....	33

GENERAL REMARKS

The attached report shall not be reproduced except in full without the written permission of Timco Engineering Inc.

Summary

The device under test does:

- Fulfill the general approval requirements as identified in this test report and was selected by the customer.
- Not fulfill the general approval requirements as identified in this test report

Attestations

This equipment has been tested in accordance with the standards identified in this test report. To the best of my knowledge and belief, these tests were performed using the measurement procedures described in this report.

All instrumentation and accessories used to test products for compliance to the indicated standards are calibrated regularly in accordance with ISO 17025 requirements.

I attest that the necessary measurements were made at:

Timco Engineering Inc.
849 NW State Road 45
Newberry, FL 32669



Tested by: _____

Name and Title: Project Manager/Testing Technician

Date: 8/ 3/ 2016



Reviewed and approved by: _____ Name and Title:

Sid Sanders, Engineer

Date: 8/ 5/ 2016

GENERAL INFORMATION

EUT Specification

EUT Description	VHF REPEATER - FIXED MOUNTED
FCC ID	LEA-R01VHF
Model Number	R01VHFT
Operating Frequency	138-174 MHz
Test Frequencies	150.85, 161.00, 173.35 MHz
Type of Emission	16K0F3E, 11K0F3E, 7K8FXD, 7K8FXE, 7K8FXW, 8K2F1D, 8K2F1E
Modulation	FM, C4FM, TDMA
EUT Power Source	<input checked="" type="checkbox"/> 120/240VAC Main input option 1: 85 to 264 VAC, 47 to 63 Hz (120 VAC 60 Hz test voltage)
	<input type="checkbox"/> DC Power 12V
	<input type="checkbox"/> Battery Operated Exclusively
Test Item	<input type="checkbox"/> Prototype
	<input type="checkbox"/> Pre-Production
	<input checked="" type="checkbox"/> Production
Type of Equipment	<input checked="" type="checkbox"/> Fixed
	<input type="checkbox"/> Mobile
	<input type="checkbox"/> Portable
Test Conditions	Temperature: 24-26°C Relative Humidity: 50 - 65%.
Modification to the EUT	None
Test Exercise	The EUT was modulated as required by standard.
Regulatory Standard	FCC CFR 47 Part 90
Measurement Standard	ANSI/TIA 603-D:2010 ANSI C63.4 – 2014 (SITE VALIDATION) RSS-GEN ISSUE 4 RSS-119 ISSUE 12
Test Facility	Timco Engineering Inc. at 849 NW State Road 45 Newberry, FL 32669 USA.

TEST RESULTS SUMMARY

Test Description	FCC RULE PART NO.	RSS-119 Spec.	RESULT
Modulation Characteristics	2.1047(a)(b)	NA	Pass
RF Power Output	2.1046(a), 90.205	5.4	Pass
Occupied Bandwidth	2.1049(c)(h), 90.210	5.5, 5.8	Pass
Spurious Emissions at Antenna Terminal	2.1051(a), 90.210	5.8	Pass
Field Strength of Spurious Radiation	2.1053, 90.210	5.8	Pass
Frequency Stability	2.1055, 90.213	5.3	Pass
Transient Frequency Response	90.214	5.9	Pass

RF POWER OUTPUT

Rule Part No.: Part 2.1046(a), Part 90.205

Test Requirements: Limit on power is geographically dependent. The Rf power is measured and reported only

Method of Measurement: RF power is measured by using a 50-ohm, resistive wattmeter to the RF output connector. With a nominal battery voltage (if battery operated), or a properly adjusted power supply (if not battery operated), and the transmitter properly adjusted the RF output measures:

Test Setup Diagram :

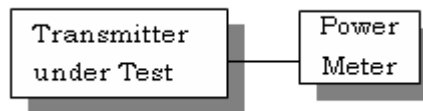

Test Data: Conducted Power Output Table

Tuned Frequency (MHz)	MEASURED RF POWER		RATED RF POWER	
	(W)	(dBm)	(W)	(dBm)
150.85	91.2	49.6	100	50
161.00	87.1	49.4	100	50
173.35	95.5	49.8	100	50

Results Meet Requirements

MODULATION CHARACTERISTICS

Requirements: Part 2.1033(c), 2.1033(c) (4), 2.1047(a)(b), 90.209, 90.207

BANDWIDTH CALCULATION

Type of Emission: 11K0F3E

$$B_n = 2M + 2DK$$

$$M = 3000$$

$$D = 2500$$

$$K = 1$$

$$B_n = 2(3000) + 2(2500) = 11.0k$$

Type of Emission: 16K0F3E

$$B_n = 2M + 2DK$$

$$M = 3000$$

$$D = 5000$$

$$K = 1$$

$$B_n = 2(3000) + 2(5000) = 16.0k$$

APCO 25 modulation phase 1 and phase 2 as defined in ANSI/ TIA-102.BABA.

Results Meet Requirements

MODULATION CHARACTERISTICS

AUDIO FREQUENCY RESPONSE

Rule Part No.: Part 2.1047(a) (b)

Test Requirements: Reporting Only

Method of Measurement: Per standard listed above, for Audio Frequency Response

TEST DATA:

AUDIO FREQUENCY RESPONSE – 12.5 kHz

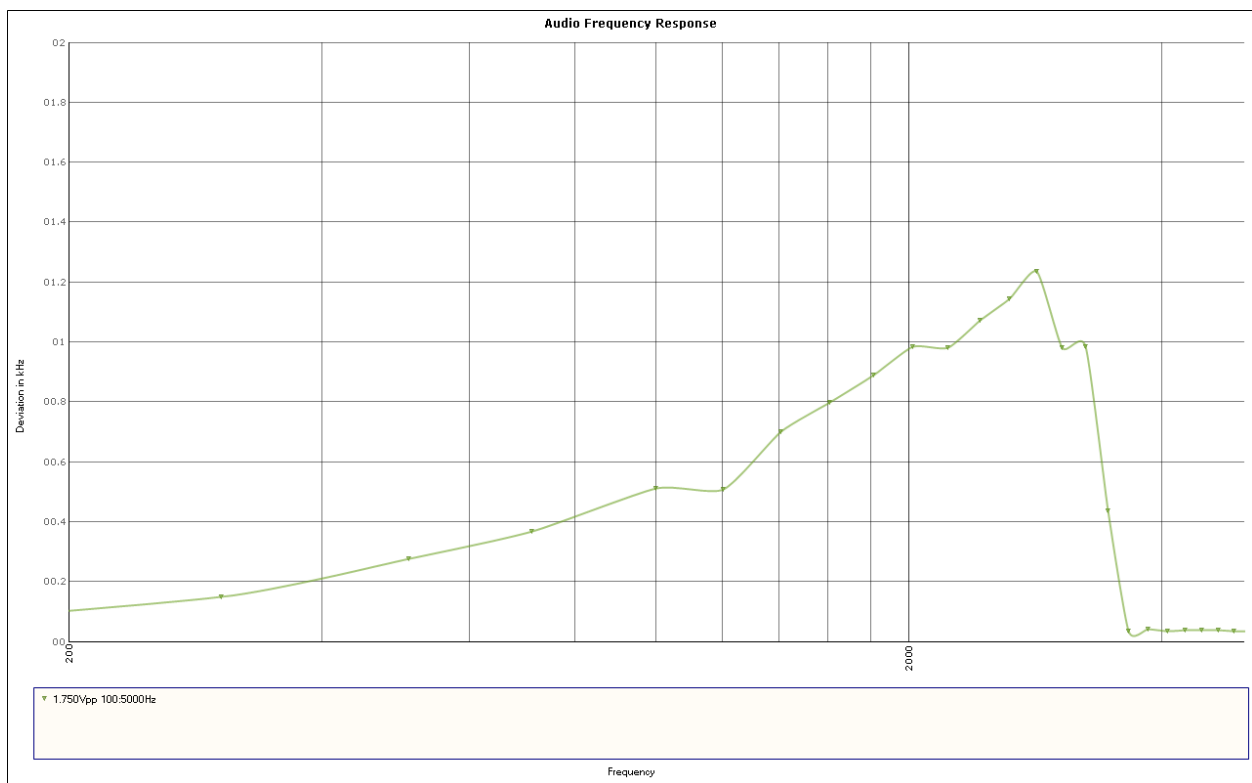

Results Meet Requirements

**PLOT
MODULATION CHARACTERISTICS**

AUDIO FREQUENCY RESPONSE

AUDIO FREQUENCY RESPONSE – 25 kHz

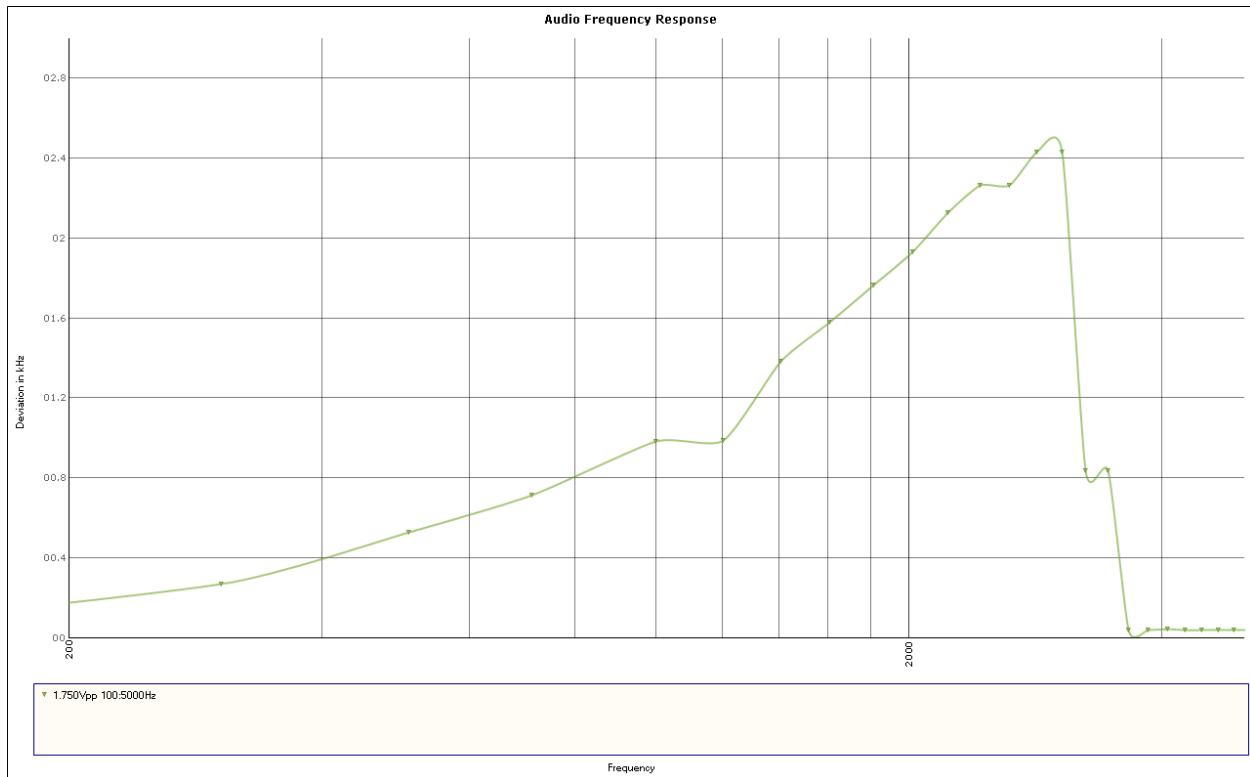

Results Meet Requirements

MODULATION CHARACTERISTICS

AUDIO LOW PASS FILTER

Rule Part No.: Part 2.1047(a) (b)

Test Requirements: For equipment required to have an audio low-pass filter, a curve showing the frequency response of the filter or of all the circuitry installed between the modulation limiter and the modulated stage shall be submitted.

Method of Measurement: Per standard listed above, for Audio Low pass filter Response

TEST DATA:

AUDIO LOW PASS FILTER 12.5 kHz

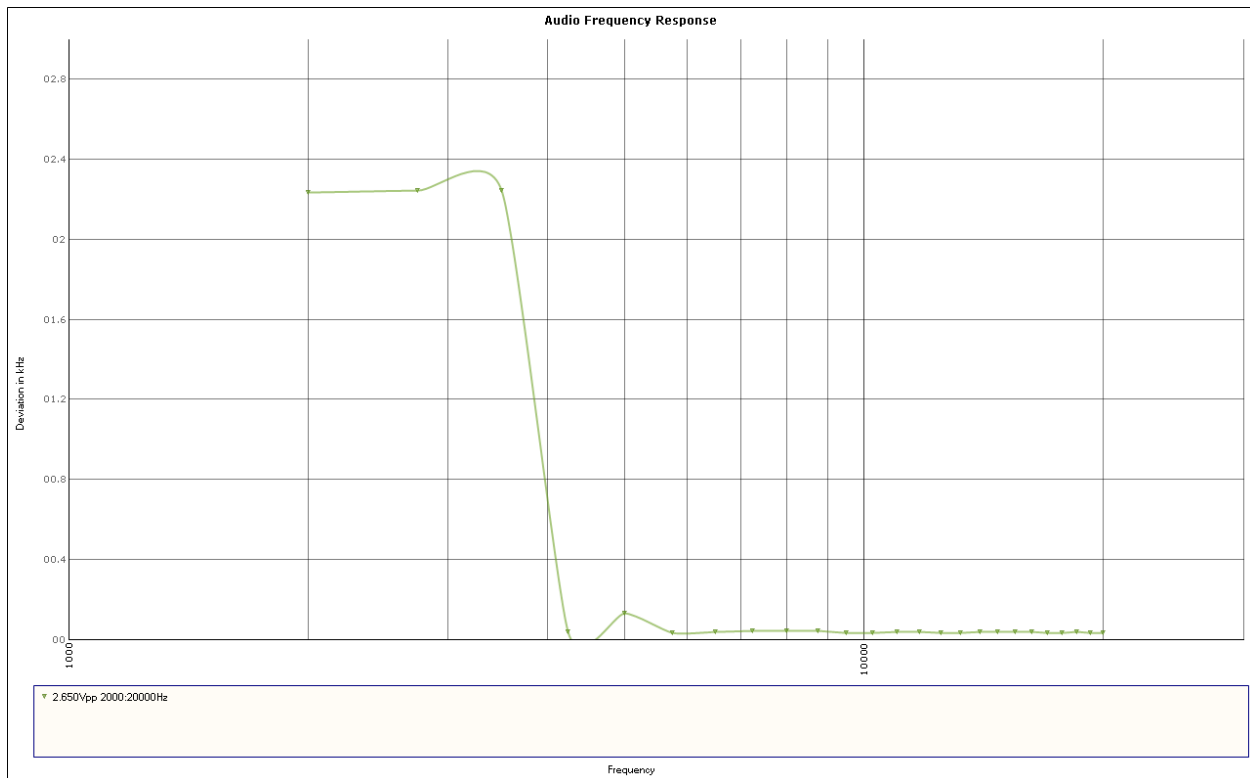

Results Meet Requirements

MODULATION CHARACTERISTICS

AUDIO LOW PASS FILTER 25 kHz

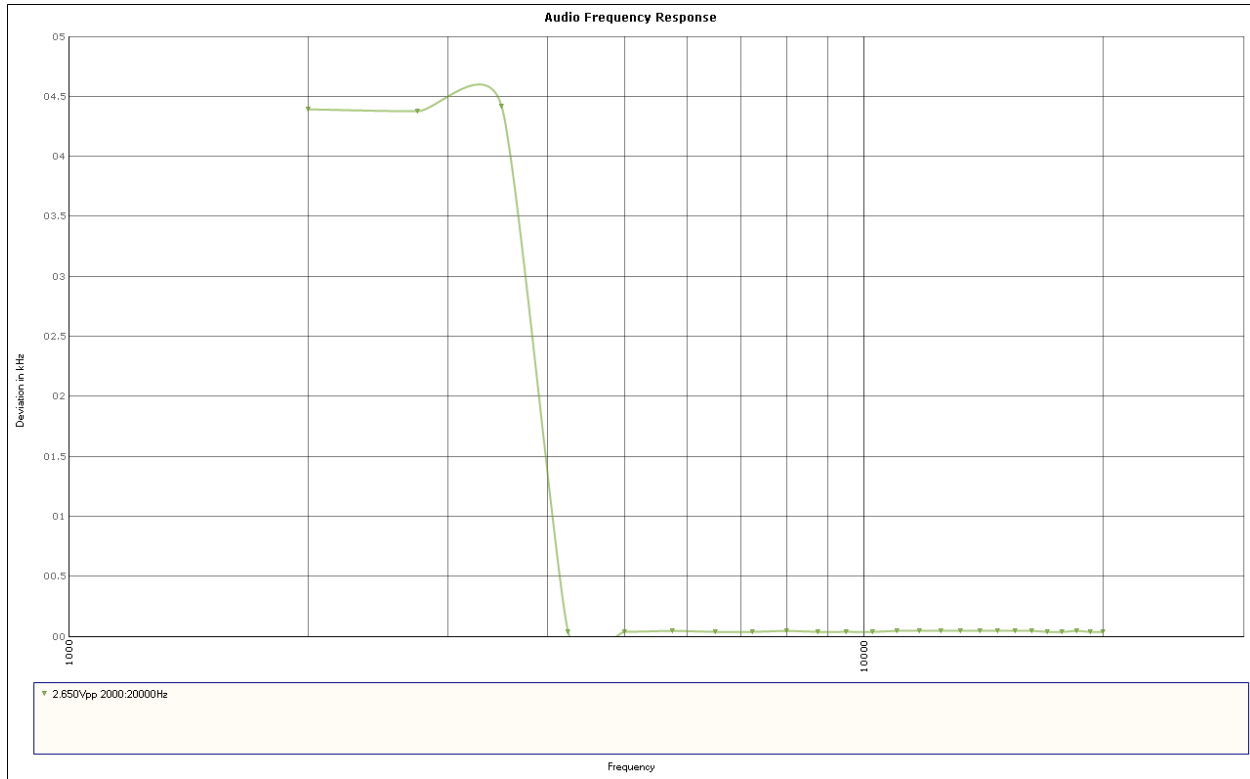

Results Meet Requirements

MODULATION CHARACTERISTICS –

AUDIO INPUT VERSUS MODULATION

RULE PART NO: Part 2.1047(b) & 90

REQUIREMENT Modulation cannot exceed 100% of the rated FM deviation.

Method of Measurement: Per standard listed above.

Test data:

MODULATION LIMITING 12.5 kHz

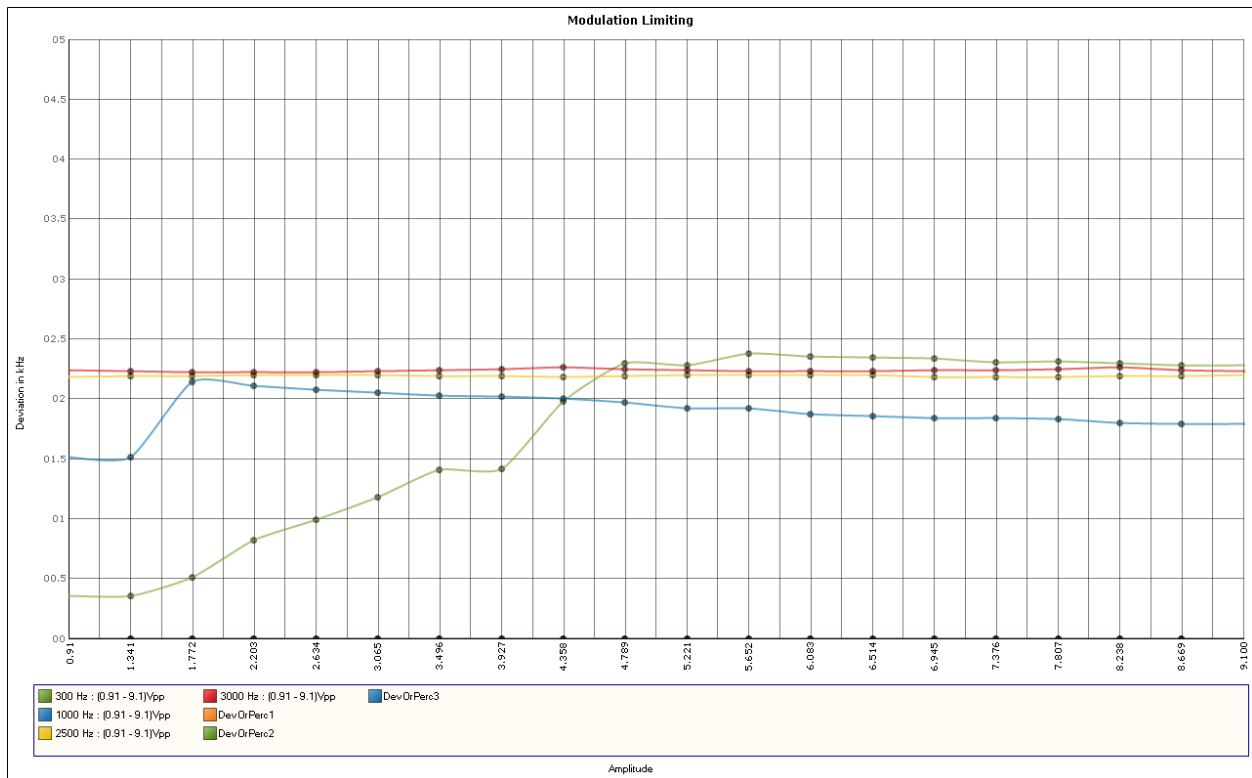

Results Meet Requirements

MODULATION CHARACTERISTICS

AUDIO INPUT VERSUS MODULATION

MODULATION LIMITING 25 kHz

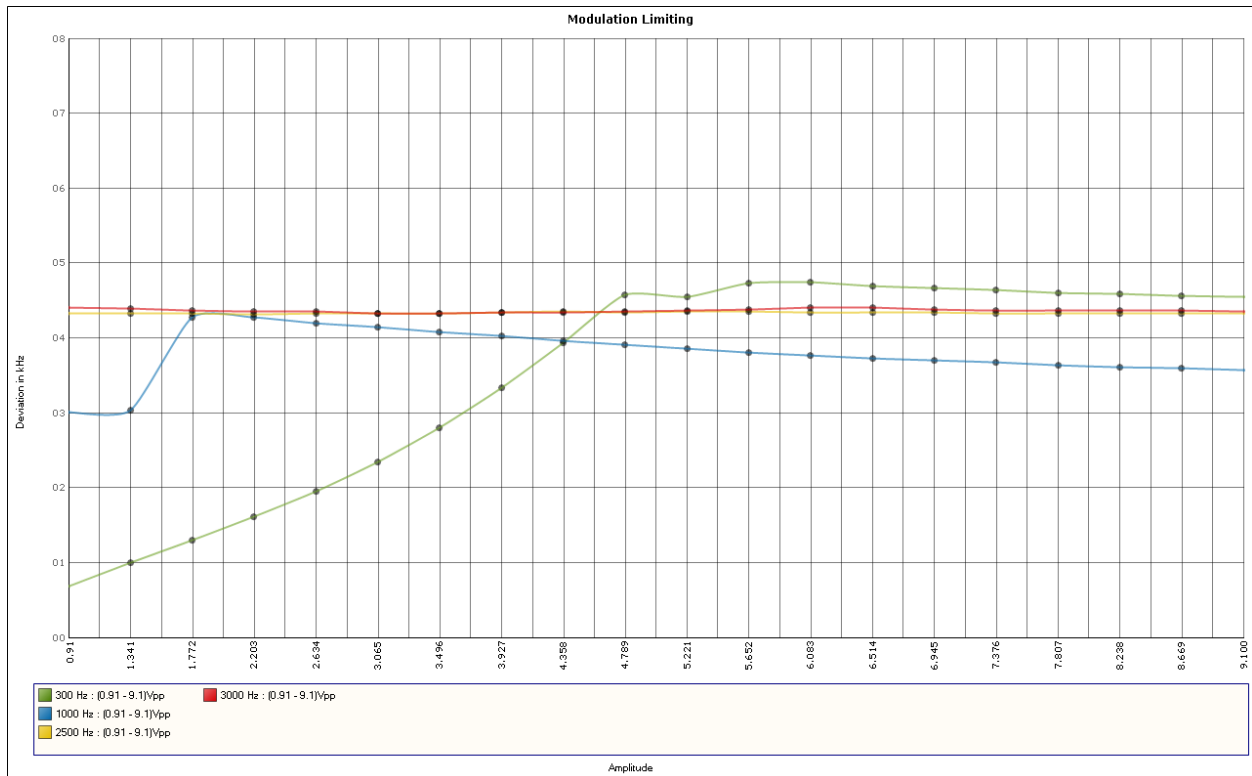

Results Meet Requirements

OCCUPIED BANDWIDTH

RULE PART NO.: 2.1049(c) & 90.210, RSS-119 5.5, 5.8

REQUIREMENTS: Applicable Emission Masks

Frequency band (MHz)	Mask for equipment with audio low pass filter	Mask for equipment without audio low pass filter
138-144, 148-149.9, 150.05 – 174 ²	B, D or E	C, D or E
150-174 ²		

²Equipment designed to operate with a 25 kHz channel bandwidth must meet the requirements of Emission Mask B or C, as applicable. Equipment designed to operate with a 12.5 kHz channel bandwidth must meet the requirements of Emission Mask D, and equipment designed to operate with a 6.25 kHz channel bandwidth must meet the requirements of Emission Mask E.

METHOD OF MEASUREMENT: Per standard listed above, for Sideband Spectrum

SETUP DIAGRAM:

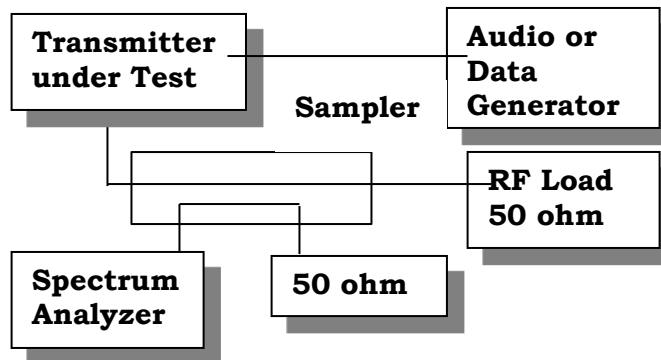

TEST DATA: See the plots on following pages.

OCCUPIED BANDWIDTH

TEST FREQ. 150.85 MHz-16k0F3E

Part 90.210(b) Emission Mask B – Equipment with audio Low pass filter

	Marker 1 [T1]	RBW	300 Hz	RF Att	20 dB
	Ref Lvl	49.05 dBm	VBW	1 kHz	
	54.2 dBm	150.85270541 MHz	SWT	5.6 s	Unit dBm

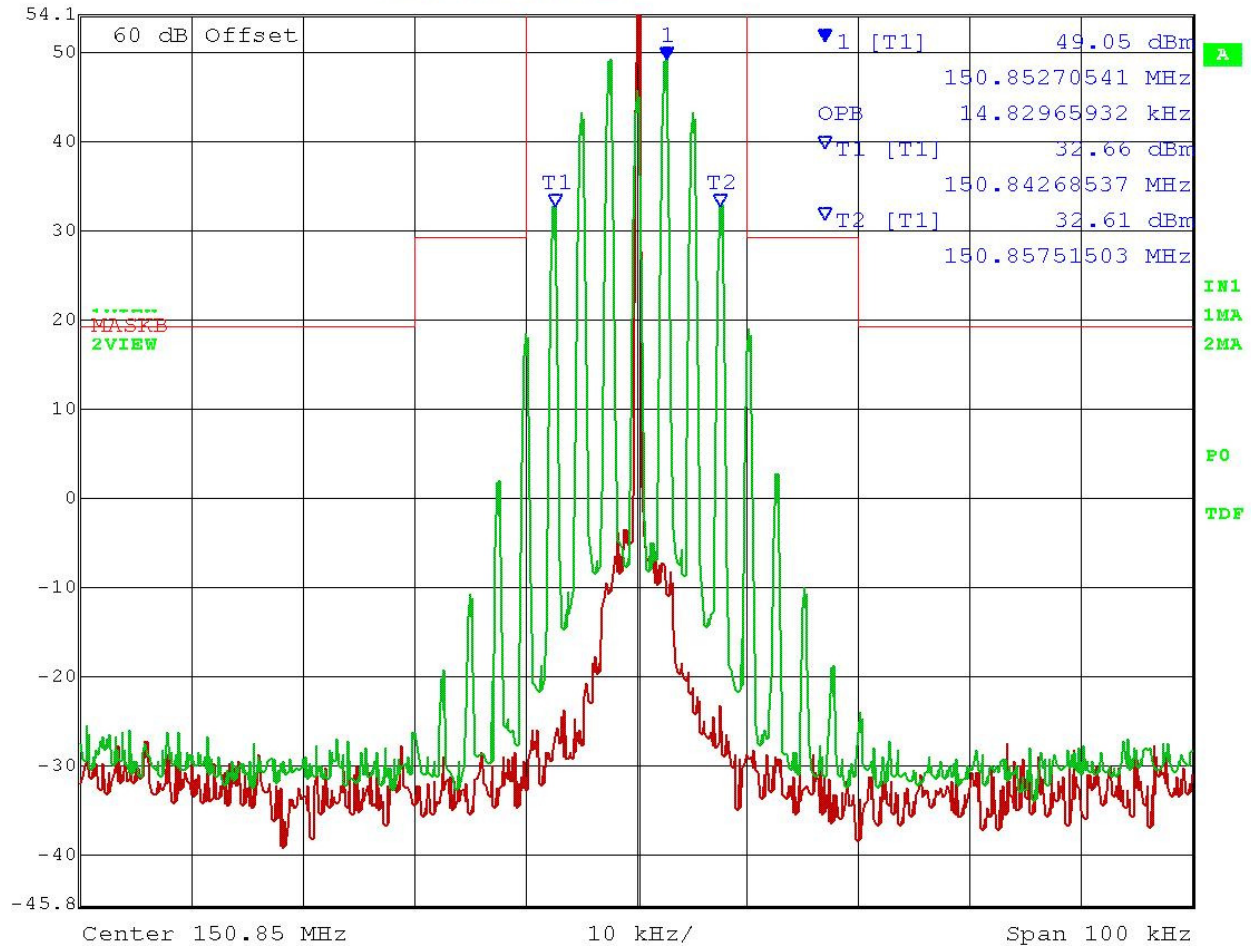

Date: 2.MAY.2016 16:35:41

Results Meet Requirements

OCCUPIED BANDWIDTH

TEST FREQ. 150.85 MHz-11k0F3E

Part 90.210(d) Emission Mask D – 12.5 KHz Equipment with audio Low pass filter

	Marker 1 [T1]	RBW	100 Hz	RF Att	20 dB
	Ref Lvl	51.76 dBm	VBW	300 Hz	
	53.5 dBm	150.85011122 MHz	SWT	56 s	Unit dBm

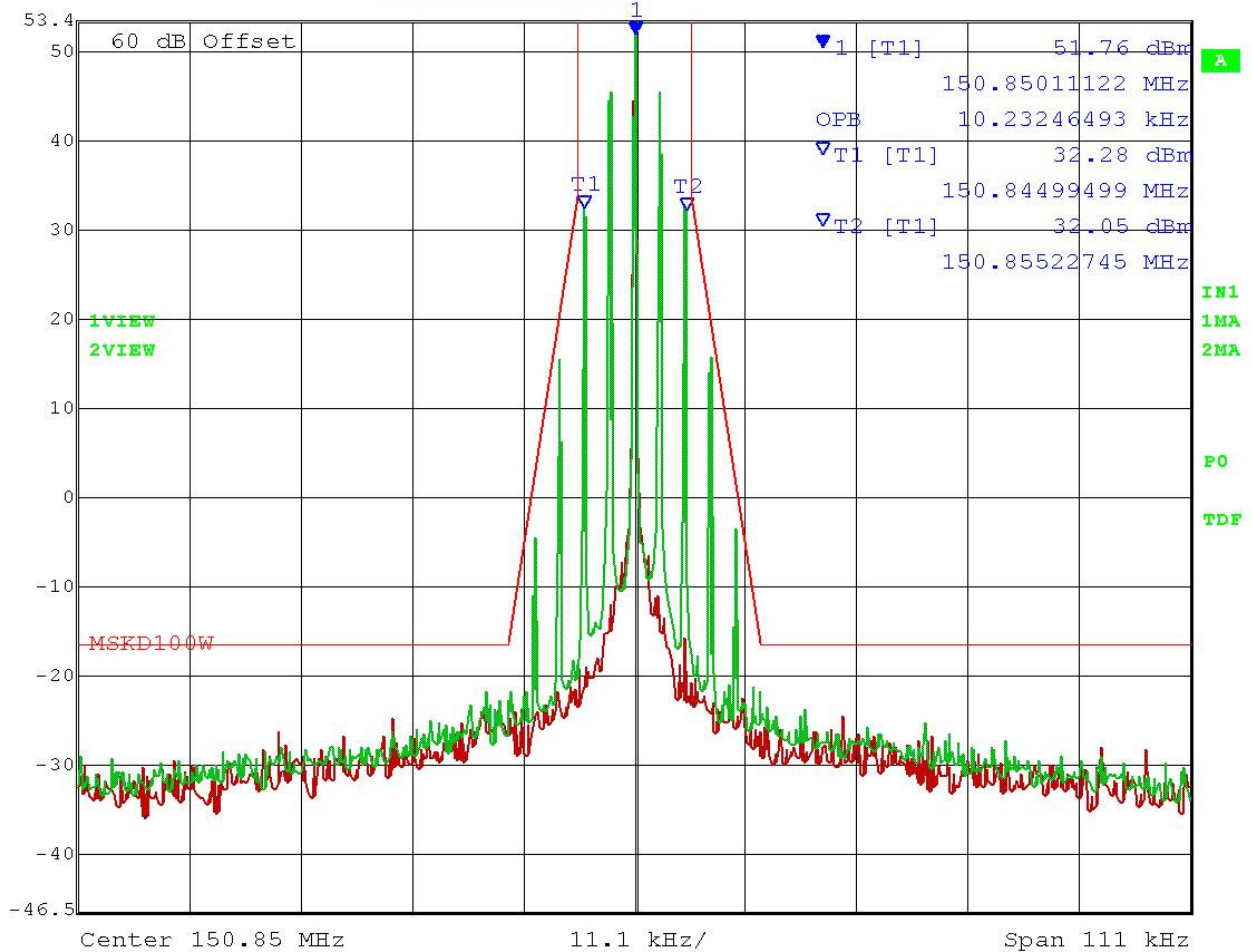

Date: 3.MAY.2016 13:22:13

Results Meet Requirements

OCCUPIED BANDWIDTH

TEST FREQ. 150.85 MHz-8K2F1E/ 8K2F1D

Part 90.210(d) Emission Mask D – 12.5 KHz Equipment with audio Low pass filter

	Marker 1 [T1]	RBW	100 Hz	RF Att	20 dB
	Ref Lvl	50.06 dBm	VBW	300 Hz	
	54 dBm	150.85077856 MHz	SWT	56 s	Unit dBm

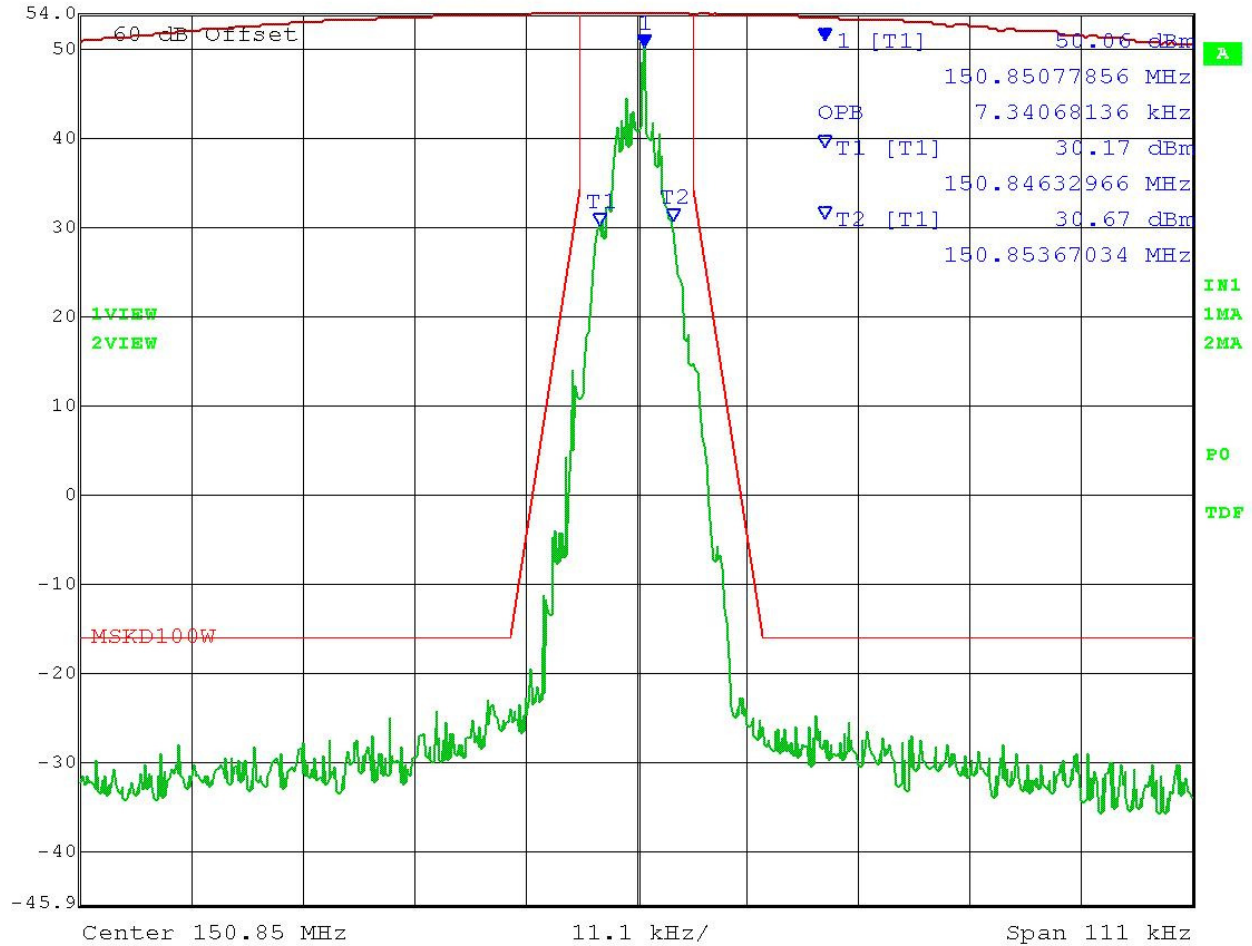

Date: 3.MAY.2016 12:52:10

Results Meet Requirements

OCCUPIED BANDWIDTH

TEST FREQ. 150.85 MHz-7K8FXD/ 7K8FXW/ 7K8FXE

Part 90.210(d) Emission Mask D – 12.5 KHz Equipment with audio Low pass filter

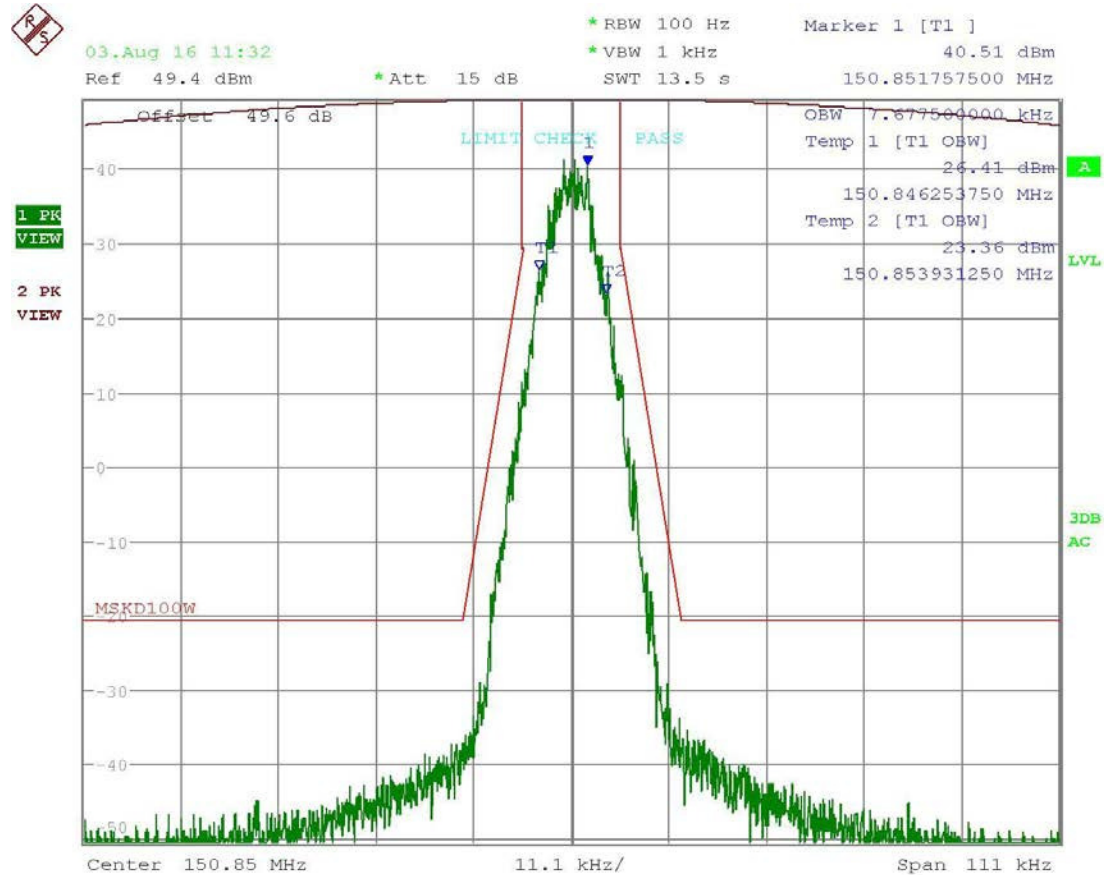

Date: 3.AUG.2016 11:32:24

Results meet requirements

SPURIOUS EMISSIONS AT ANTENNA TERMINALS

RULE PART NO.: **RULE PART NO.:** Part 2.1051(a), 90.210, RSS-119 5.8

REQUIREMENTS:

Transmit Band (MHz)	Equipment Type	Rule Part	Requirement
150-174 ²	6.25 KHz equipment With or Without Audio Low Pass Filter	90.210(c)(3)	55 + 10 log (P) or 65 dB, whichever is the lesser attenuation
	12.5 KHz equipment With or Without Audio Low Pass Filter	90.210(d)(3)	50 + 10 log (P) dB or 70 dB, whichever is the lesser attenuation.
	25 KHz equipment With or without Audio Low Pass Filter	90.210(b)(3)	43 + 10log (P) dB

²Equipment designed to operate with a 25 kHz channel bandwidth must meet the requirements of Emission Mask B or C, as applicable. Equipment designed to operate with a 12.5 kHz channel bandwidth must meet the requirements of Emission Mask D, and equipment designed to operate with a 6.25 kHz channel bandwidth must meet the requirements of Emission Mask E.

METHOD OF MEASUREMENT: Per standard listed above, for Unwanted Emissions:
Conducted Spurious

SPURIOUS EMISSIONS AT ANTENNA TERMINALS

TEST FREQ. 150.85 MHz

	dBm	Watts	Limit dBc
Power Output	49.6	91.20	69.6
	Frequency MHz	dBc	Margin dB
	150.85	0	0.0
	301.70	89.2	19.6
	452.55	92.9	23.3
*	603.40	108.6	39.0
	754.25	105.7	36.1
*	905.10	103.2	33.6
*	1055.95	99.3	29.7
*	1206.80	100.2	30.6
*	1357.65	101.2	31.6
*	1508.50	99.7	30.1

* Indicates only the noise floor was present

Results Meet Requirements

SPURIOUS EMISSIONS AT ANTENNA TERMINALS

TEST FREQ. 161.00 MHz

	dBm	Watts	Limit dBc
Power Output	49.4	87.10	69.4
	Frequency MHz	dBc	Margin dB
	161.00	0	0.0
	322.00	90.2	20.8
	483.00	106.7	37.3
*	644.00	105.4	36.0
*	805.00	105.0	35.6
*	966.00	103.0	33.6
*	1127.00	98.7	29.3
*	1288.00	99.9	30.5
*	1449.00	99.0	29.6
*	1610.00	98.1	28.7

* Indicates only the noise floor was present

Results Meet Requirements

SPURIOUS EMISSIONS AT ANTENNA TERMINALS

TEST FREQ. 173.35 MHz

	dBm	Watts	Limit dBc
Power Output	49.8	95.50	69.8
	Frequency MHz	dBc	Margin dB
	173.35	0	0.0
	346.70	89.8	20.0
	520.05	97.2	27.4
*	693.40	105.6	35.8
	866.75	94.5	24.7
*	1040.10	100.6	30.8
*	1213.45	100.3	30.5
*	1386.80	99.4	29.6
*	1560.15	97.2	27.4
*	1733.50	98.5	28.7

* Indicates only the noise floor was present

Results Meet Requirements

FIELD STRENGTH OF SPURIOUS RADIATION EMISSIONS

RULE PARTS. NO.: Part 2.1053, 90.210, RSS-119 5.8

REQUIREMENTS: Out of Band Emission Limits

Transmit Band (MHz)	Equipment Type	Rule Part	Requirement
150-174 ²	6.25 KHz equipment With or Without Audio Low Pass Filter	90.210(c)(3)	55 + 10 log (P) or 65 dB, whichever is the lesser attenuation
	12.5 KHz equipment With or Without Audio Low Pass Filter	90.210(d)(3)	50 + 10 log (P) dB or 70 dB, whichever is the lesser attenuation.
	25 KHz equipment With or without Audio Low Pass Filter	90.210(b)(3)	43 + 10log (P) dB

²Equipment designed to operate with a 25 kHz channel bandwidth must meet the requirements of Emission Mask B or C, as applicable. Equipment designed to operate with a 12.5 kHz channel bandwidth must meet the requirements of Emission Mask D, and equipment designed to operate with a 6.25 kHz channel bandwidth must meet the requirements of Emission Mask E.

METHOD OF MEASUREMENT: The following test methods were used
Per standard listed above, for Unwanted Emissions: Radiated Spurious
(Out of Band Emissions from 9 KHz – Tenth Harmonic of Fundamental)

FIELD STRENGTH OF SPURIOUS RADIATION EMISSIONS

TEST SETUP DIAGRAM:

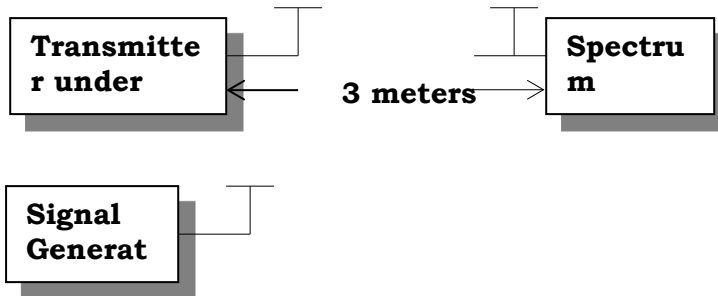

FIELD STRENGTH OF SPURIOUS RADIATION EMISSIONS

TEST FREQ. 150.85 MHz

Emission Frequency (MHz)	Power Mode	Power Output (dBm)	Power Output (Watts)	Requirement dB	Bandwidth - BW - kHz
150.85	Hi	49.60	91.20	69.60	12.50
Emission Frequency (MHz)	Ant. Polarity		Below Carrier (dBc)	Margin dB	
301.70	H		124.09	54.49	
452.55	H		82.65	13.05	
603.40	V		110.56	40.96	
754.25	H		87.32	17.72	
905.10	H		84.31	14.71	
1,055.95	V		104.99	35.39	
1,206.80	V		109.75	40.15	
1,357.65	H		109.63	40.03	
1,508.50	H		104.04	34.44	

FIELD STRENGTH OF SPURIOUS RADIATION EMISSIONS

TEST FREQ. 161.00 MHz

Emission Frequency (MHz)	Power Mode	Power Output (dBm)	Power Output (Watts)	FCC Requirement dB	Bandwidth - BW - kHz
161.00	Hi	49.40	87.10	69.40	12.50
Emission Frequency (MHz)	Ant. Polarity		Below Carrier (dBc)	Margin dB	
322.00	H		122.43	53.03	
483.00	H		97.49	28.09	
644.00	V		112.08	42.68	
805.00	V		111.99	42.59	
966.00	H		95.21	25.81	
1,127.00	V		103.41	34.01	
1,288.00	V		105.38	35.98	
1,449.00	V		100.66	31.26	
1,610.00	V		108.20	38.80	

Results meet requirements

TEST FREQ. 173.35 MHz

Emission Frequency (MHz)	Power Mode	Power Output (dBm)	Power Output (Watts)	Requirement dB	Bandwidth - BW - kHz
173.35	Hi	49.80	95.50	69.80	12.50
Emission Frequency (MHz)	Ant. Polarity		Below Carrier (dBc)	Margin dB	
346.70	H		123.04	53.24	
520.05	H		97.89	28.09	
693.40	V		116.67	46.87	
866.75	V		73.50	3.70	
1,040.10	V		104.12	34.32	
1,213.45	V		111.95	42.15	
1,386.80	H		88.49	18.69	
1,560.15	V		93.72	23.92	
1,733.50	V		91.71	21.91	

Results meet requirements

FREQUENCY STABILITY

RULE PARTS. NO.: Part 2.1055, Part 90.213, RSS-119 5.3

Requirements: Temperature range requirements: -30 to +50° C.
Voltage Variation +, -15%

Frequency Band (MHz)	Frequency Stability (PPM)	Channel Bandwidth (KHz)
150 – 174	±1.0	6.25
	±2.5	12.5
	±5	25

METHOD OF MEASUREMENTS: Per standard listed above, for Carrier Frequency Stability

Test Data: 173.35 MHz 11K0F3E

All modes of operation were checked in each band, the worst case is reported below.

Temperature	Frequency MHz	Cycles	PPM
25°C (reference)	173350064	0	0
-30°C	173350068	4000000	0.023
-20°C	173350037	-27000000	-0.156
-10°C	173350053	-11000000	-0.063
0°C	173350052	-12000000	-0.069
10°C	173350047	-17000000	-0.098
20°C	173350007	-57000000	-0.329
30°C	173350007	-57000000	-0.329
40°C	173350008	-56000000	-0.323
50°C	173350007	-57000000	-0.329
Supply Voltage (VAC)	Frequency	Cycles	PPM
138.00	173350064	0	0.000
120.00	173350064	0	0.000
102.00	173350064	0	0.000

Results meet requirements

TRANSIENT FREQUENCY RESPONSE

RULE PARTS. NO.: 90.214, RSS-119 5.9

Requirements: Transmitters designed to operate in the 150-174 MHz and 421-512 MHz frequency bands must maintain transient frequencies within the maximum transient frequencies within the maximum frequency difference limits during the time intervals indicated:

Time intervals ^{1 2}	Maximum frequency difference ³	All equipment	
		150 to 174 MHz	421 to 512 MHz
Transient Frequency Behavior for Equipment Designed to Operate on 25 kHz Channels			
t_1^4	±25.0 kHz	5.0 ms	10.0 ms
t_2	±12.5 kHz	20.0 ms	25.0 ms
t_3^4	±25.0 kHz	5.0 ms	10.0 ms
Transient Frequency Behavior for Equipment Designed to Operate on 12.5 kHz Channels			
t_1^4	±12.5 kHz	5.0 ms	10.0 ms
t_2	±6.25 kHz	20.0 ms	25.0 ms
t_3^4	±12.5 kHz	5.0 ms	10.0 ms
Transient Frequency Behavior for Equipment Designed to Operate on 6.25 kHz Channels			
t_1^4	±6.25 kHz	5.0 ms	10.0 ms
t_2	±3.125 kHz	20.0 ms	25.0 ms
t_3^4	±6.25 kHz	5.0 ms	10.0 ms

¹ t_{on} is the instant when a 1 kHz test signal is completely suppressed, including any capture time due to phasing.

t_1 is the time period immediately following t_{on} .

t_2 is the time period immediately following t_1 .

t_3 is the time period from the instant when the transmitter is turned off until t_{off} .

t_{off} is the instant when the 1 kHz test signal starts to rise.

² During the time from the end of t_2 to the beginning of t_3 , the frequency difference must not exceed the limits specified in §90.213.

³ Difference between the actual transmitter frequency and the assigned transmitter frequency.

⁴ If the transmitter carrier output power rating is 6 watts or less, the frequency difference during this time period may exceed the maximum frequency difference for this time period.

TRANSIENT FREQUENCY RESPONSE

METHOD OF MEASUREMENTS: Per standard listed above, for Carrier Frequency Stability

TEST SETUP DIAGRAM:

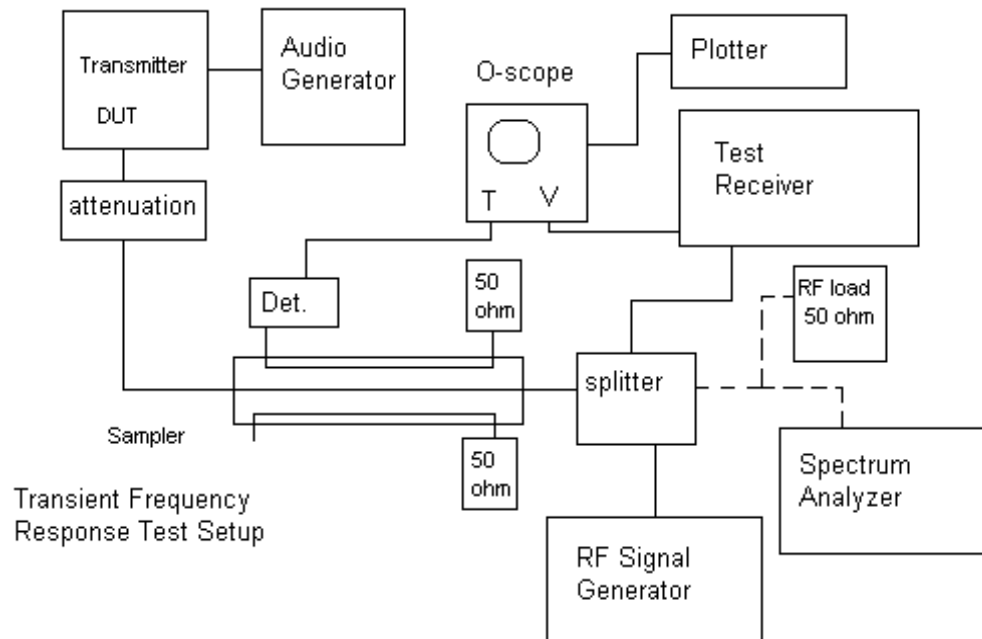

TRANSIENT FREQUENCY RESPONSE

Test Data: 12.5 KHz Channel Spacing Turn On

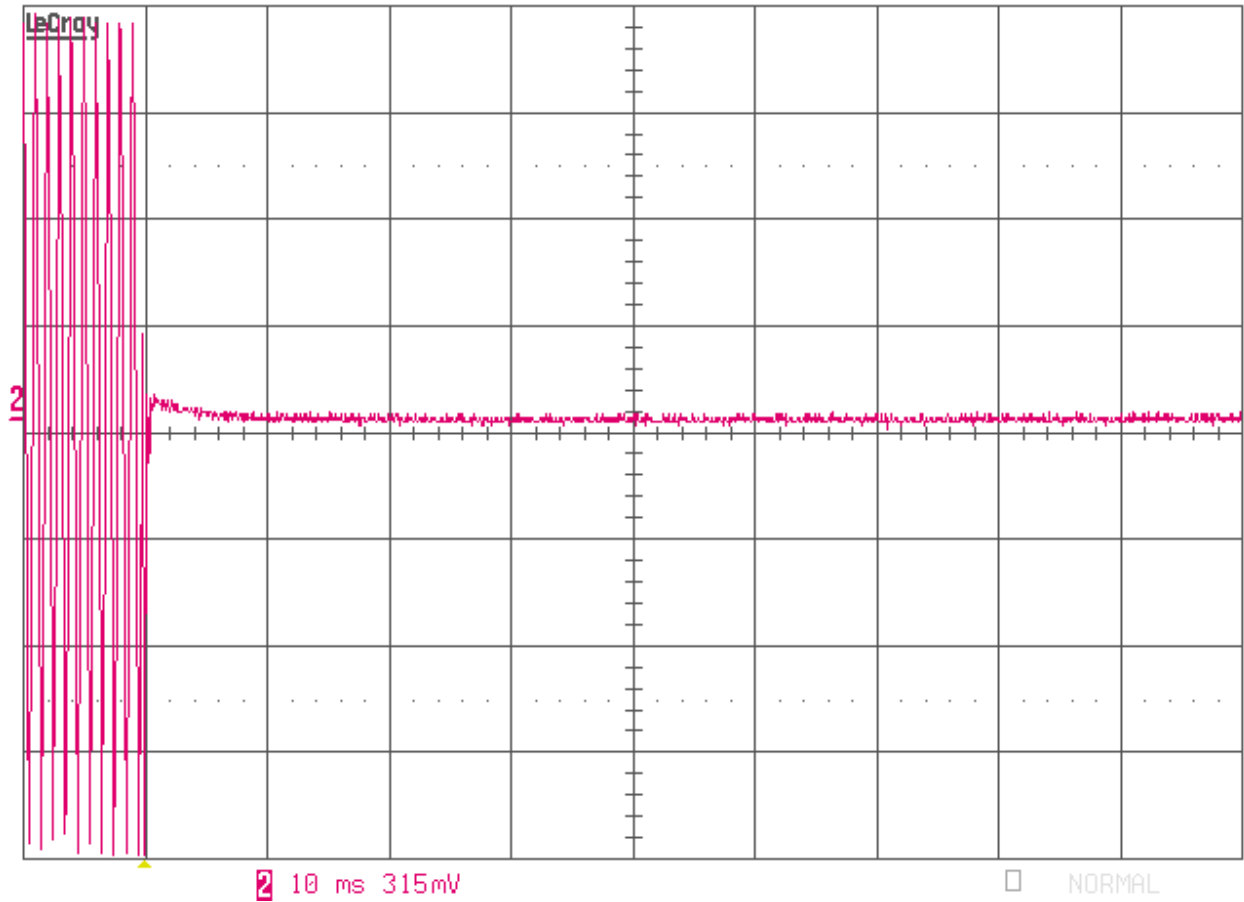

Results meet requirements

TRANSIENT FREQUENCY RESPONSE

Test Data: 12.5 KHz Channel Spacing Turn Off

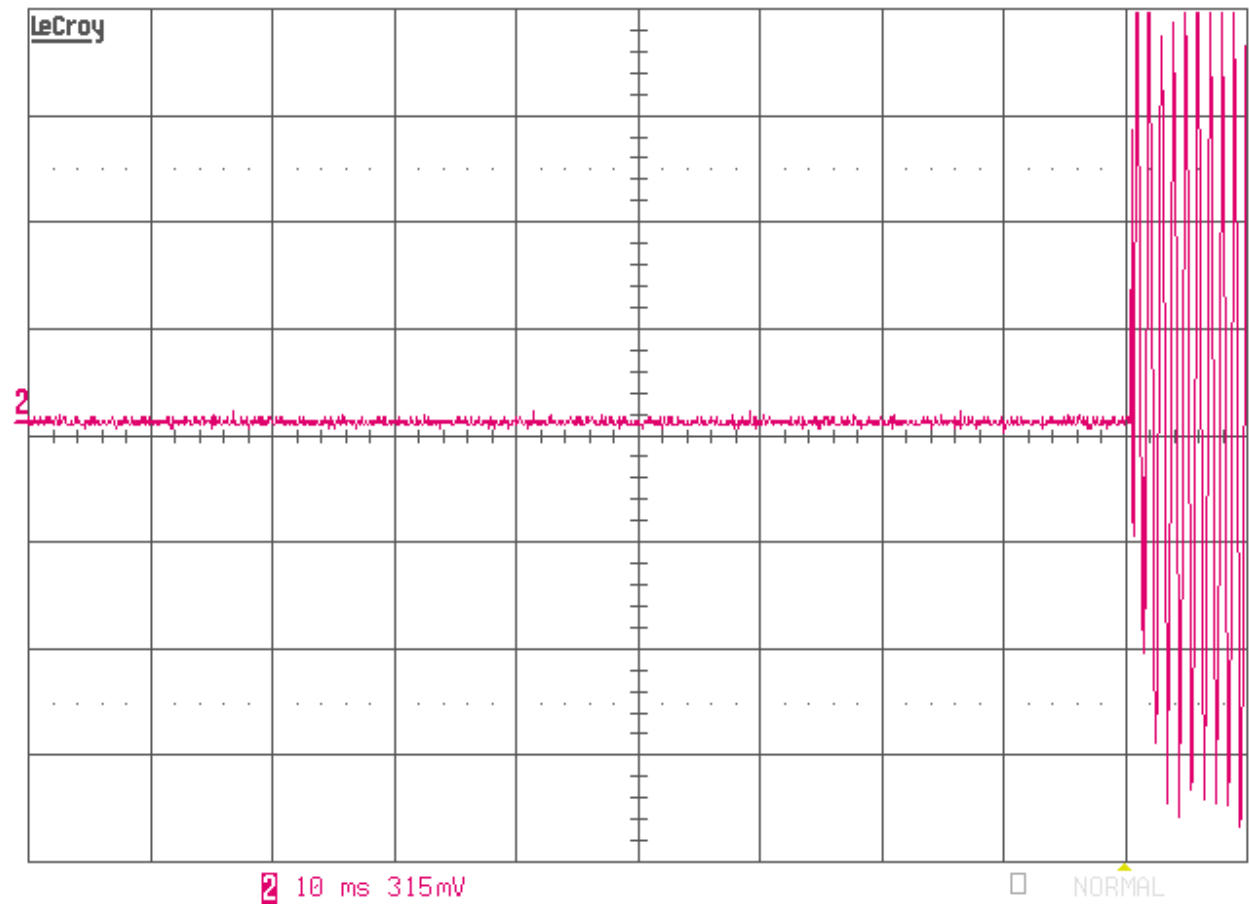

Results meet requirements

TRANSIENT FREQUENCY RESPONSE

Test Data: 25 KHz Channel Spacing Turn On

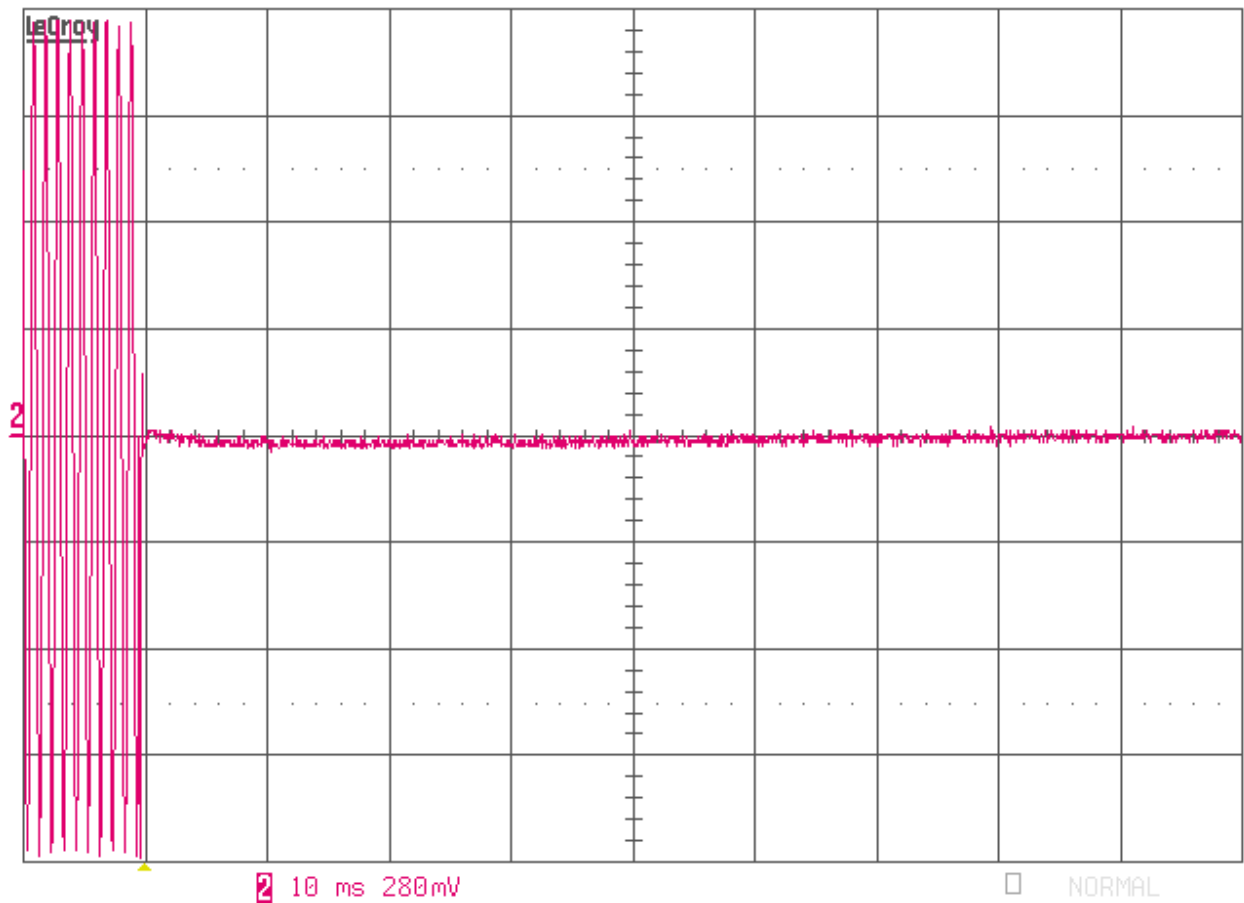

Results meet requirements

TRANSIENT FREQUENCY RESPONSE

Test Data: 25 KHz Channel Spacing Turn Off

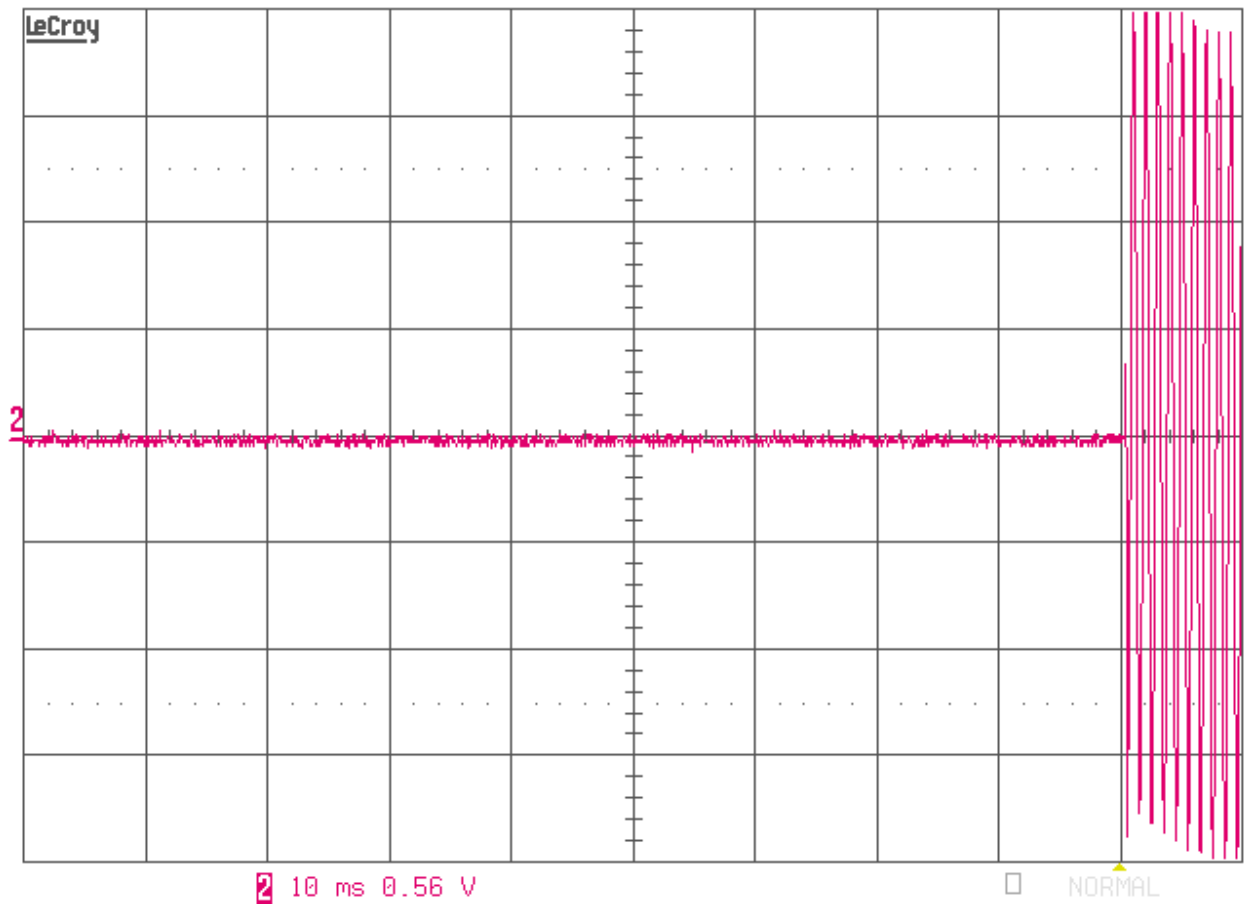

Results meet requirements

EQUIPMENT LIST

Device	Manufacturer	Model	Serial Number	Cal/ Char Date	Due Date
Antenna: Biconnical 1096	Eaton	94455-1	1096	07/14/15	07/14/17
Antenna: Log-Periodic 1122	Electro-Metrics	LPA-25	1122	07/14/15	07/14/17
Antenna: Double-Ridged Horn/ETS Horn 2	ETS-Lindgren Chamber	3117	00041534	02/25/15	02/25/17
Temperature Chamber LARGE	Tenney Engineering	TTRC	11717-7	08/19/14	08/19/16
AC Voltmeter	HP	400FL	2213A14728	10/24/15	10/24/17
Digital Multimeter	Fluke	77	35053830	10/21/15	10/21/17
Frequency Counter Large Chamber	HP	5352B	2632A00165	07/01/15	07/01/17
CHAMBER	Panashield	3M	N/A	04/25/16	12/31/17
EMI Test Receiver R & S ESIB 40 Screen Room	Rohde & Schwarz	ESIB 40	100274	08/12/14	08/12/16
Software: Field Strength Program	Timco	N/A	Version 4.0	NA	NA
Antenna: Active Loop	ETS-Lindgren	6502	00062529	11/18/15	11/18/17
Hygro-Thermometer	Extech	445703	0602	06/30/15	06/30/17
Attenuator N 30dB 150W DC-6G	Narda	769-30	10267	06/26/15	06/26/17
EMI Test Receiver R & S ESU 40 Chamber	Rohde & Schwarz	ESU 40	100320	04/01/16	04/01/18
Signal Generator HP 8648C	HP	8648C	3623A02898	02/08/16	02/08/18
Function Generator	Standford	DS340	25200	02/02/16	02/02/18
Modulation Analyzer	HP	8901A	3050A05856	4/16/15	4/16/17
Tuneable Notch Filter 54-210 MHz	Eagle	210BFBF	54-210 MHz	09/16/15	09/16/17

* EMI RECEIVER SOFTWARE VERSION

The receiver firmware used was version 4.43 Service Pack 3

END OF TEST REPORT