

Test Report # TR\_4164-20\_FCC\_PT90\_2

Revision: 2

Issue Date: November 19, 2020

Final Test Date: November 16, 2020



## Test Report - FCC PART 90 (TNB)

Prepared For: UNICATION CO., LTD.

Approved for Release By:

Signature: Bruno Clavier

Name & Title: Bruno Clavier, General Manager

Date of Signature

(YYYY-MM-DD): 2020-11-19

This test report shall not be reproduced except in full without the written and signed permission of Timco Engineering Inc. (IIA). This test report relates only to the items tested as identified and is not valid for any subsequent changes or modifications made to the equipment under test.



## Table of Contents

---

<b>1.</b>	<b>CUSTOMER INFORMATION.....</b>	<b>5</b>
1.1	PART 80 TEST RESULT SUMMARY .....	5
1.2	PART 90 TEST RESULT SUMMARY .....	6
<b>2.</b>	<b>LOCATION OF TESTING .....</b>	<b>7</b>
2.1	TEST LABORATORY .....	7
2.2	TESTING WAS PERFORMED, REVIEWED BY .....	7
<b>3.</b>	<b>TEST SAMPLE(S) (EUT/DUT).....</b>	<b>8</b>
3.1	DESCRIPTION OF THE EUT.....	8
3.2	CONFIGURATION OF EUT .....	9
3.3	TEST SETUP OF EUT.....	10
<b>4.</b>	<b>TEST METHODS &amp; APPLICABLE REGULATORY LIMITS.....</b>	<b>11</b>
4.1	TEST METHODS/STANDARDS/GUIDANCE: .....	11
4.2	APPLIED LIMITS AND REGULATORY LIMITS:.....	11
<b>5.</b>	<b>MEASUREMENT UNCERTAINTY.....</b>	<b>11</b>
<b>6.</b>	<b>ENVIRONMENTAL CONDITIONS .....</b>	<b>11</b>
6.1	TEMPERATURE & HUMIDITY.....	11
<b>7.</b>	<b>LIST OF TEST EQUIPMENT AND TEST FACILITY.....</b>	<b>12</b>
7.1	LIST OF TEST EQUIPMENT .....	12
<b>8.</b>	<b>TEST RESULTS .....</b>	<b>13</b>
8.1	POWER AT THE FINAL AMPLIFIER.....	14
8.2	RF OUTPUT POWER .....	15
8.2.1	<i>Power Output, 763.0125 MHz.....</i>	<i>16</i>
8.2.2	<i>Power Output, 774.9875 MHz .....</i>	<i>17</i>
8.2.3	<i>Power Output, 804.9875 MHz.....</i>	<i>18</i>
8.2.4	<i>Power Output, 806.0125 MHz .....</i>	<i>19</i>
8.2.5	<i>Power Output, 823.9875 MHz .....</i>	<i>20</i>
8.2.6	<i>Power Output, 851.0125 MHz .....</i>	<i>21</i>
8.2.7	<i>Power Output, 868.9875 MHz.....</i>	<i>22</i>
8.3	BANDWIDTH & EMISSION.....	23
8.3.1	<i>Bandwidth Plot, 99%, 11K0F3E, 774.9875 MHz.....</i>	<i>24</i>
8.3.1	<i>Bandwidth Plot, 99%, 16K0F3E, 774.9875 MHz .....</i>	<i>25</i>
8.3.1	<i>Bandwidth Plot, 99%, 8K10F1E/F1D, 774.9875 MHz.....</i>	<i>26</i>
8.3.1	<i>Bandwidth Plot, 99%, 7K80FXE/FXD/FXW, 774.9875 MHz.....</i>	<i>27</i>
8.3.2	<i>Bandwidth Plot, 99%, 11K0F3E, 823.9875 MHz.....</i>	<i>28</i>
8.3.1	<i>Bandwidth Plot, 99%, 16K0F3E, 823.9875 MHz.....</i>	<i>29</i>
8.3.2	<i>Bandwidth Plot, 99%, 8K10F1E/F1D, 823.9875 MHz.....</i>	<i>30</i>
8.3.3	<i>Bandwidth Plot, 99%, 7K80FXE/FXD/FXW, 823.9875 MHz.....</i>	<i>31</i>



8.4	EMISSION LIMITATIONS, IN-BAND.....	32
8.4.1	Emission Mask, 11K0F3E, 763.0125 MHz.....	33
8.4.1	Emission Mask, 16K0F3E, 763.0125 MHz.....	34
8.4.1	Emission Mask, 8K10F1E/F1D, 763.0125 MHz.....	35
8.4.1	Emission Mask, 7K80FXE/FXD/FXW, 763.0125 MHz.....	36
8.4.2	Emission Mask, 11K0F3E, 774.9875 MHz.....	37
8.4.3	Emission Mask, 16K0F3E, 774.9875 MHz.....	38
8.4.4	Emission Mask, 8K10F1E/F1D, 774.9875 MHz.....	39
8.4.5	Emission Mask, 7K80FXE/FXD/FXW, 774.9875 MHz.....	40
8.4.6	Emission Mask, 11K0F3E, 804.9875 MHz.....	41
8.4.7	Emission Mask, 16K0F3E, 804.0125 MHz.....	42
8.4.8	Emission Mask, 8K10F1E/F1D, 804.0125 MHz.....	43
8.4.9	Emission Mask, 7K80FXE/FXD/FXW, 804.0125 MHz.....	44
8.4.10	Emission Mask, 11K0F3E, 806.0125 MHz.....	45
8.4.11	Emission Mask, 16K0F3E, 806.0125 MHz.....	46
8.4.12	Emission Mask, 8K10F1E/F1D, 806.0125 MHz.....	47
8.4.13	Emission Mask, 7K80FXE/FXD/FXW, 806.0125 MHz.....	48
8.4.14	Emission Mask, 11K0F3E, 823.9875 MHz.....	49
8.4.15	Emission Mask, 16K0F3E, 823.9875 MHz.....	50
8.4.16	Emission Mask, 8K10F1E/F1D, 823.9875 MHz.....	51
8.4.17	Emission Mask, 7K80FXE/FXD/FXW, 823.9875 MHz.....	52
8.4.18	Emission Mask, 11K0F3E, 851.0125 MHz.....	53
8.4.19	Emission Mask, 16K0F3E, 851.0125 MHz.....	54
8.4.20	Emission Mask, 8K10F1E/F1D, 851.0125 MHz.....	55
8.4.21	Emission Mask, 7K80FXE/FXD/FXW, 851.0125 MHz.....	56
8.4.22	Emission Mask, 11K0F3E, 868.9875 MHz.....	57
8.4.23	Emission Mask, 16K0F3E, 868.0125 MHz.....	58
8.4.24	Emission Mask, 8K10F1E/F1D, 868.0125 MHz.....	59
8.4.25	Emission Mask, 7K80FXE/FXD/FXW, 868.0125 MHz.....	60
8.5	EMISSION LIMITATIONS, OUT-OF-BAND.....	61
8.5.1	Conducted Emissions, 30 MHz to 1 GHz, 763.0125 MHz.....	62
8.5.2	Conducted Emissions, 1 GHz to 10 <sup>th</sup> Harmonic, 763.0125 MHz.....	63
8.5.3	Conducted Emissions, 30 MHz to 1 GHz, 774.9875 MHz.....	64
8.5.4	Conducted Emissions, 1 GHz to 10 <sup>th</sup> Harmonic, 774.9875 MHz.....	65
8.5.5	Conducted Emissions, 30 MHz to 1 GHz, 804.9875 MHz.....	66
8.5.6	Conducted Emissions, 1 GHz to 10 <sup>th</sup> Harmonic, 804.0125 MHz.....	67
8.5.7	Conducted Emissions, 30 MHz to 1 GHz, 806.0125 MHz.....	68
8.5.8	Conducted Emissions, 1 GHz to 10 <sup>th</sup> Harmonic, 806.0125 MHz.....	69
8.5.9	Conducted Emissions, 30 MHz to 1 GHz, 823.9875 MHz.....	70
8.5.10	Conducted Emissions, 1 GHz to 10 <sup>th</sup> Harmonic, 823.9875 MHz.....	71
8.5.11	Conducted Emissions, 30 MHz to 1 GHz, 851.0125 MHz.....	72
8.5.12	Conducted Emissions, 1 GHz to 10 <sup>th</sup> Harmonic, 851.0125 MHz.....	73
8.5.13	Conducted Emissions, 30 MHz to 1 GHz, 868.9875 MHz.....	74
8.5.14	Conducted Emissions, 1 GHz to 10 <sup>th</sup> Harmonic, 868.0125 MHz.....	75
8.6	RADIATED EMISSIONS.....	76
8.6.1	Radiated Emissions, 763.0125 MHz.....	77



8.6.2	<i>Radiated Emissions, 774.9875 MHz</i> .....	77
8.6.3	<i>Radiated Emissions, 804.9875 MHz</i> .....	78
8.6.4	<i>Radiated Emissions, 806.0125 MHz</i> .....	79
8.6.5	<i>Radiated Emissions, 823.9875 MHz</i> .....	79
8.6.6	<i>Radiated Emissions, 851.0125 MHz</i> .....	80
8.6.7	<i>Radiated Emissions, 868.9875 MHz</i> .....	80
8.7	MODULATION CHARACTERISTICS.....	81
8.7.1	<i>Audio Frequency Response, Narrowband FM</i> .....	82
8.7.1	<i>Audio Frequency Response, Wideband FM</i> .....	83
8.7.2	<i>Low Pass Filter Response, Narrowband FM</i> .....	84
8.7.1	<i>Low Pass Filter Response, Wideband FM</i> .....	85
8.7.2	<i>Modulation Limiting, Narrowband FM</i> .....	86
8.7.1	<i>Modulation Limiting, Wideband FM</i> .....	87
8.8	FREQUENCY STABILITY.....	88
8.8.1	<i>Frequency Stability Data</i> .....	89
8.8.2	<i>Frequency Stability Plot</i> .....	90
8.9	TRANSIENT FREQUENCY BEHAVIOR.....	91
8.10	ADJACENT CHANNEL POWER LIMITS.....	92
9.	ANNEX-A - PHOTOGRAPHS OF THE EUT.....	93
10.	ANNEX-B – TEST SETUP PHOTOGRAPHS.....	93
11.	HISTORY OF TEST REPORT CHANGES.....	93



Timco Engineering, Inc., an IIA Company  
849 NW State Road 45, Newberry, Florida 32669  
(352) 472-5500 / [testing@timcoengr.com](mailto:testing@timcoengr.com)

## 1. Customer Information

**Applicant:** UNICATION CO., LTD.  
**Address:** 5F., No. 6, Wu-Kung 5 Road  
Hsinchuang City, Taipei, Taiwan

**Contact::** Mr. Robert Marchetto  
**Telephone:** 604-205-7450 x3315  
**Email address:** [rmarchetto@uniamericas.com](mailto:rmarchetto@uniamericas.com)

### 1.1 Part 90 Test Result Summary

The following test procedure and guidance were used for measuring FCC PART 90 (PRIVATE LAND MOBILE RADIO SERVICES) known as Licensed Land Mobile; ANSI C63.26-2015. Full test results are available in this report.

The Following is for Test item FCC ID: LEA-R017800

Applicable Clauses from Part 2		
FCC Clauses	Description of the requirements	Result: (Pass, Fail, N/A)
2.202	Bandwidth & Emission	Pass
2.1033 (c)(8)	Power at the Final Amplifier	Reported
2.1046 (a)	RF Output Power	Pass
2.1047	Modulation characteristics	Pass
2.1049	Occupied Bandwidth	Pass
2.1051	Spurious emissions at antenna terminals	Pass
2.1053	Field strength of spurious radiation	Pass
2.1055	Frequency stability	Pass



## 1.2 Part 90 Test Result Summary

Applicable Clauses from Part 90		
FCC Clauses	Description of the requirements	Result: (Pass, Fail, N/A)
90.205 (r)	Transmitter Power	Pass
90.207 (n)	Emission designator	Reported
90.209 (b) (5) footnote 2	Bandwidth limitations	Pass
90.210 (n)	Emission masks, In-band	Pass
90.210 (n)	Emission masks, Out-of-band	Pass
90.213 (a) footnote 10	Frequency stability	Pass
90.214	Transient Frequency Behavior	n/a
90.221	Adjacent channel power limits	n/a

No additions to the test methods were needed. There were no deviations, or exclusions from the test methods. No test results are from external providers or from the customer. The test results relate only to the items tested. Timco does not offer opinions and interpretations, only a pass/fail statement.



Timco Engineering, Inc., an IIA Company  
 849 NW State Road 45, Newberry, Florida 32669  
 (352) 472-5500 / [testing@timcoengr.com](mailto:testing@timcoengr.com)

## 2. Location of Testing

### 2.1 Test Laboratory

Timco Engineering Inc. is a subsidiary of Industrial Inspection & Analysis, Inc. ("IIA").  
 Testing was performed at Timco's permanent laboratory located at 849 NW State Road 45, Newberry, Florida 32669

FCC test firm # 578780  
 FCC Designation # US1070  
 FCC site registration is under A2LA certificate # 0955.01  
 ISED Canada test site registration # 2056A  
 EU Notified Body # 1177  
 For all designations see A2LA scope # 0955.01

### 2.2 Testing was performed, reviewed by

Dates of Testing: November 11 - 16, 2020

Signature:  \_\_\_\_\_

Name & Title: Franklin Rose, EMC Specialist

Date of Signature  
 (YYYY-MM-DD): 2020-11-19

Signature:  \_\_\_\_\_

Sr. EMC Engineer  
 EMC-003838-NE



Name & Title: Tim Royer, EMC Engineer

Date of Signature  
 (YYYY-MM-DD): 2020-11-19



### 3. Test Sample(s) (EUT/DUT)

The test sample was received: November 2, 2020

#### 3.1 Description of the EUT

A description as well as unambiguous identification of the EUT(s) tested. Where more than one sample is required for technical reasons (such as the use of connected units for the purpose of conducted output power testing where the product units will have integral antennas), each specific test shall identify which unit was tested.

Identification	
FCC ID:	LEA-R017800
Brief Description	700/800 MHz Repeater
Type of Modular	n/a
Model(s) #	R017800T (TX); R017800R (RX)
Trade name	n/a
Firmware version	n/a
Software version	DSP version RP1 Nov 27 2019 01:42 GMT 002R GE
Serial Number(s)	CR01 sn: R01SRB80001 TX01 sn: R01STB800001 CR01 sn: R01SRB80002 TX01 sn: R01STB800002

Technical Characteristics	
Technology	FM Analog & Digital Repeater/Base Station
Frequency Range	762 – 776 MHz, 792 - 806 MHz, 806 – 825 MHz, 851 – 870 MHz
RF O/P Power (Max.)	130 W (51.14 dBm)
Modulation	FM/CFSK
Bandwidth & Emission Class	11K0F3E, 16K0F3E, 7K80FXE, 7K80FXD, 7K80FXW, 8K10F1E, 8K10F1D
Number of Channels	Variable
Duty Cycle	Tested at 100%
Antenna Connector	N
Voltage Rating (AC or Batt.)	120/240 V AC

Antenna Characteristics				
Antenna Name	Frequency Range	Antenna Type	Dimensions	Antenna Gain
n/a	n/a	n/a	n/a	n/a

**Note:** No antenna is sold with this device.





### 3.2 Configuration of EUT

Test Modes					
Band	Mode (#)	Mode (Type)	Test Frequencies	BW (nominal)	Modulation
700 MHz	1	n/a	763.0125 MHz 774.9875 MHz 804.9875 MHz	n/a	CW
	2	n/a	763.0125 MHz 774.9875 MHz 804.9875 MHz	12.5 kHz	FM Analog
	3	n/a	763.0125 MHz 774.9875 MHz 804.9875 MHz	25 kHz	FM Analog
	4	n/a	763.0125 MHz 774.9875 MHz 804.9875 MHz	12.5 kHz	CFSK Digital
800 MHz	5	n/a	806.0125 MHz 823.9875 MHz 851.0125 MHz 868.9875 MHz	n/a	CW
	6	n/a	806.0125 MHz 823.9875 MHz 851.0125 MHz 868.9875 MHz	12.5 kHz	FM Analog
	7	n/a	806.0125 MHz 823.9875 MHz 851.0125 MHz 868.9875 MHz	25 kHz	FM Analog
	8	n/a	806.0125 MHz 823.9875 MHz 851.0125 MHz 868.9875 MHz	12.5 kHz	CFSK Digital



Timco Engineering, Inc., an IIA Company  
849 NW State Road 45, Newberry, Florida 32669  
(352) 472-5500 / [testing@timcoengr.com](mailto:testing@timcoengr.com)

### Operating conditions during Testing:

The device was operated without the provided antenna(s).

No other modifications of the device under test (including firmware, specific software settings, and input/output signal levels to the EUT) were made.

### Peripherals used during Testing:

A laptop provided by the manufacturer was used to control the EUT.

### 3.3 Test Setup of EUT

Equipment, antenna, and cable arrangement. The setup of the equipment and cable or wire placement on the test site that produces the highest radiated and the highest ac power line conducted emissions shall be shown clearly and described. Information on the orientation of portable equipment during testing shall be included. Drawings or photographs may be used for this purpose.

Test Setups are included in the test report.



#### 4. Test methods & Applicable Regulatory Limits

##### 4.1 Test methods/Standards/Guidance:

Test procedures and guidance for measuring Licensed Part 90 Licensed device:

- 1) ANSI C63.26-2015

##### 4.2 Applied Limits and Regulatory Limits:

- 1) FCC CFR 47 Part 90

#### 5. Measurement Uncertainty

Parameter	Uncertainty (dB)
Conducted Emissions	± 3.14 dB
Radiated Emissions (9kHz – 30 MHz)	± 3.08 dB
Radiated Emissions (30 – 200 MHz)	± 2.16 dB
Radiated Emissions (200 – 1000 MHz)	± 2.15 dB
Radiated Emissions (1 GHz – 18 GHz)	± 2.14 dB
Radiated Emissions (18 GHz – 40 GHz)	± 2.31 dB
<b>Note:</b> The uncertainties provided in this table represent an expanded uncertainty expressed at approximately the 95% confidence level using a coverage factor of K=2.	

#### 6. Environmental Conditions

##### 6.1 Temperature & Humidity

Measurements performed at the test site did not exceed the following:

Temperature	23 C +/- 5%
Humidity	55% +/- 5%
<b>Note:</b> Specific environmental conditions that are applicable to a specific test are available in the test result section.	



## 7. List of Test Equipment and Test Facility

The test equipment used identified by type, manufacturer, serial number, or other identification and the date on which the next calibration or service check is due.

Description of the firmware or software used to operate EUT for testing purposes.

A complete list of all test equipment used shall be included with the test report. The manufacturer's model and serial numbers, and date of last calibration, and calibration interval shall be included. Measurement cable loss, measuring instrument bandwidth and detector function, video bandwidth, if appropriate, and antenna factors shall also be included where applicable.

### 7.1 List of Test Equipment

Device	Manufacturer	Model	SN #	Current Cal	Cal Due
<a href="#">Audio Analyzer</a>	HP	8903B	3011A13084	2/20/18	2/19/2021
<a href="#">Function Generator</a>	Standford	DS340	25200	2/21/18	2/20/2021
<a href="#">Modulation Analyzer</a>	HP	8901A	3050A05856	4/23/20	4/23/2023
<a href="#">Signal Generator HP 8648C</a>	HP	8648C	3847A04696	9/11/20	9/11/2023
<a href="#">Digital Multimeter</a>	Fluke	77	35053830	9/9/20	9/9/2023
<a href="#">Frequency Counter</a>	HP	5385A	2730A03025	9/9/20	9/9/2023
<a href="#">Active Loop</a>	ETS-Lindgren	6502	00062529	10/20/20	10/20/2023
<a href="#">Biconical 1057</a>	Eaton	94455-1	1057	10/16/20	10/16/2023
<a href="#">Log-Periodic 1243</a>	Eaton	96005	1243	4/20/18	4/19/2021
<a href="#">Double-Ridged Horn/ETS Horn 1</a>	ETS-Lindgren	3117	00035923	2/25/20	2/24/2023
<a href="#">CHAMBER</a>	Panashield	3M	N/A	3/12/19	3/11/2021
<a href="#">Pre-amp</a>	RF-LAMBDA	RLNA00M45GA	NA	2/27/19	2/26/2022
<a href="#">EMI Test Receiver R&amp;S ESU 40</a>	Rohde & Schwarz	ESU 40	100320	8/28/18	8/27/2021
<a href="#">Type K J Thermometer</a>	Martel	303	080504494	12/6/17	12/5/2020

Software	Author	Version	Validation Or
ESU Firmware	Rohde & Schwarz	4.43 SP3; BIOS v5.1-24-3	2018
RSCCommander	Rohde & Schwarz	1.6.4	2014
ScopeExplorer	LeCroy	v2.25.0.0	2009
Field Strength	Timco	v4.10.7.0	2016



## 8. Test Results

The results of the test are usually indicated in the form of tables, spectrum analyzer plots, charts, sample calculations, as appropriate for each test procedure.

A description and/or a block diagram of the test setup is usually provided.

The measurement results, along with the appropriate limits for comparison, may be presented in tabular or graphical form. In addition, any variation in the measurement environment may be reported if applicable (e.g., a significant change of temperature that could affect the cable loss and amplifier response).

Unless noted otherwise in the referenced standard, the measurements of **ac power-line conducted emissions and conducted power output** will be reported in units of dB $\mu$ V. Unless noted otherwise in the referenced standard, the measurements of **radiated emissions** will be reported in units of decibels, referenced to one microvolt per meter (dB $\mu$ V/m) for electric fields, or to one ampere per meter (dBA/m) for magnetic fields, at the distance specified in the appropriate standards or requirements. The measurements of antenna-conducted power for receivers may be reported in units of dB $\mu$ V if the impedance of the measuring instrument is also reported. Otherwise, antenna-conducted power will be reported in units of decibels referenced to one milliwatt (dBm). All formulas for data conversions and conversion factors, if used, will be included in this measurement report.



### 8.1 Power at the Final Amplifier

Limits from FCC Part 2.1033 (c)(8).

No method of measurement is specified. The result has been calculated based on all available information.

Test Results		
EUT Operating Voltage (V)	EUT Current (A)	Power at the Final Amplifier
120 V AC	10 A	1200 W

## 8.2 RF Output Power

Limits from FCC Parts 2.1046(a), and 90.205 (r); and test procedure from ANSI C63.26-2015.

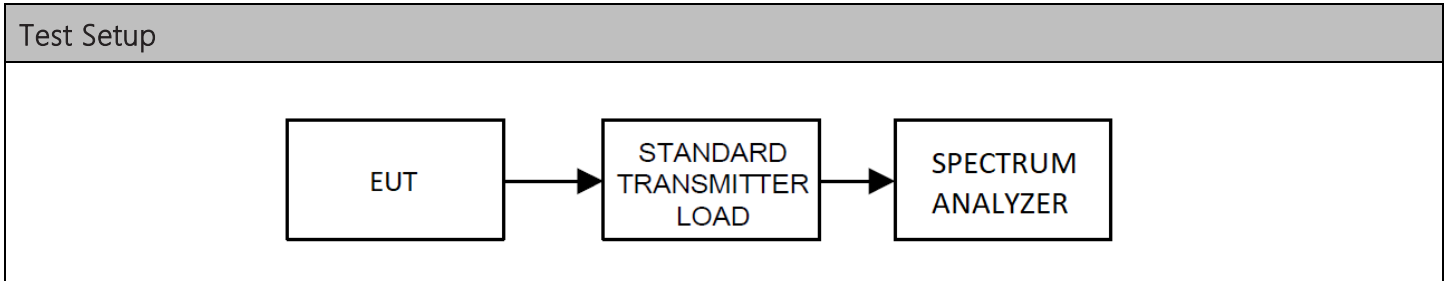

Test Results, Mode 1				
Mode	Tuned Frequency (MHz)	Method	Power Output (dBm)	Power Output (W)
1	763.0125 MHz	Conducted	51.13	129.72
	774.9875 MHz	Conducted	51.15	130.32
	804.9875 MHz	Conducted	51.16	130.62
5	806.0125 MHz	Conducted	51.13	129.72
	823.9875 MHz	Conducted	51.32	135.52
	851.0125 MHz	Conducted	51.65	146.22
	868.9875 MHz	Conducted	51.55	142.89

Rated Power Output: 130 W.

Tune-up tolerance: +/- 1 dB.



### Conducted Output Power, Spectrum Plots

#### 8.2.1 Power Output, 763.0125 MHz

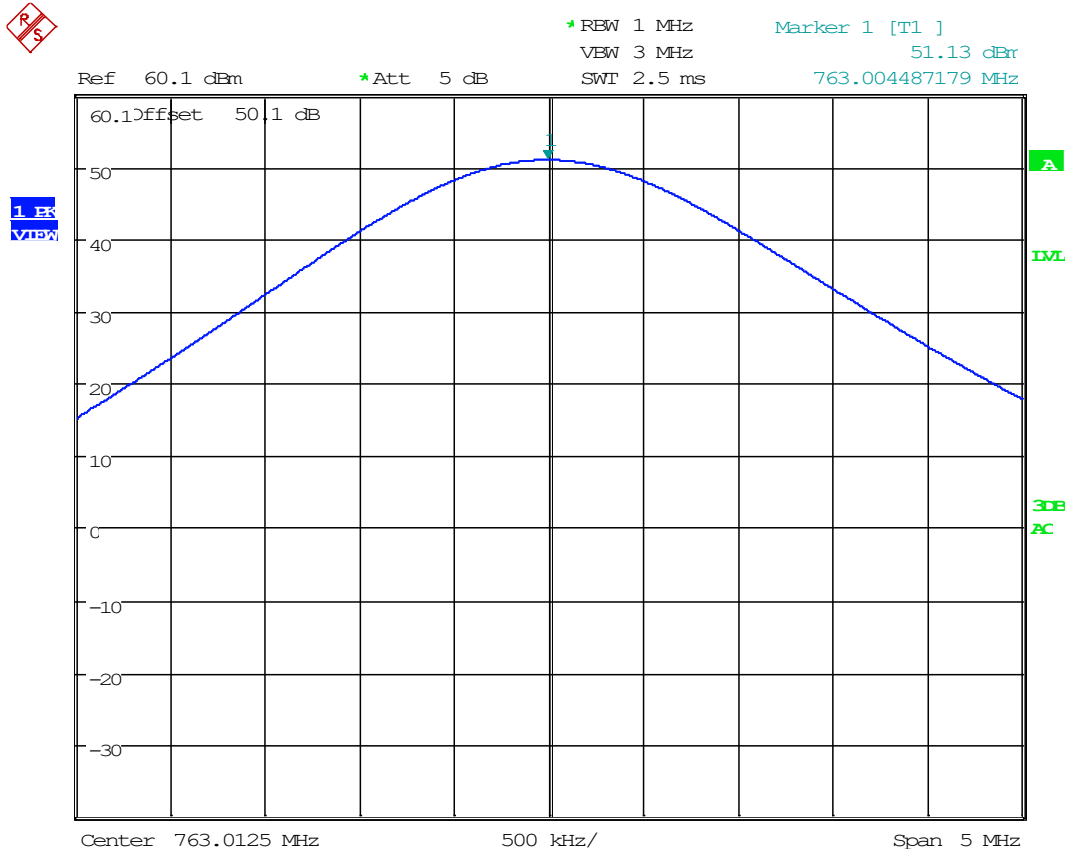

Date: 11.NOV.2020 17:10:08



### 8.2.2 Power Output, 774.9875 MHz

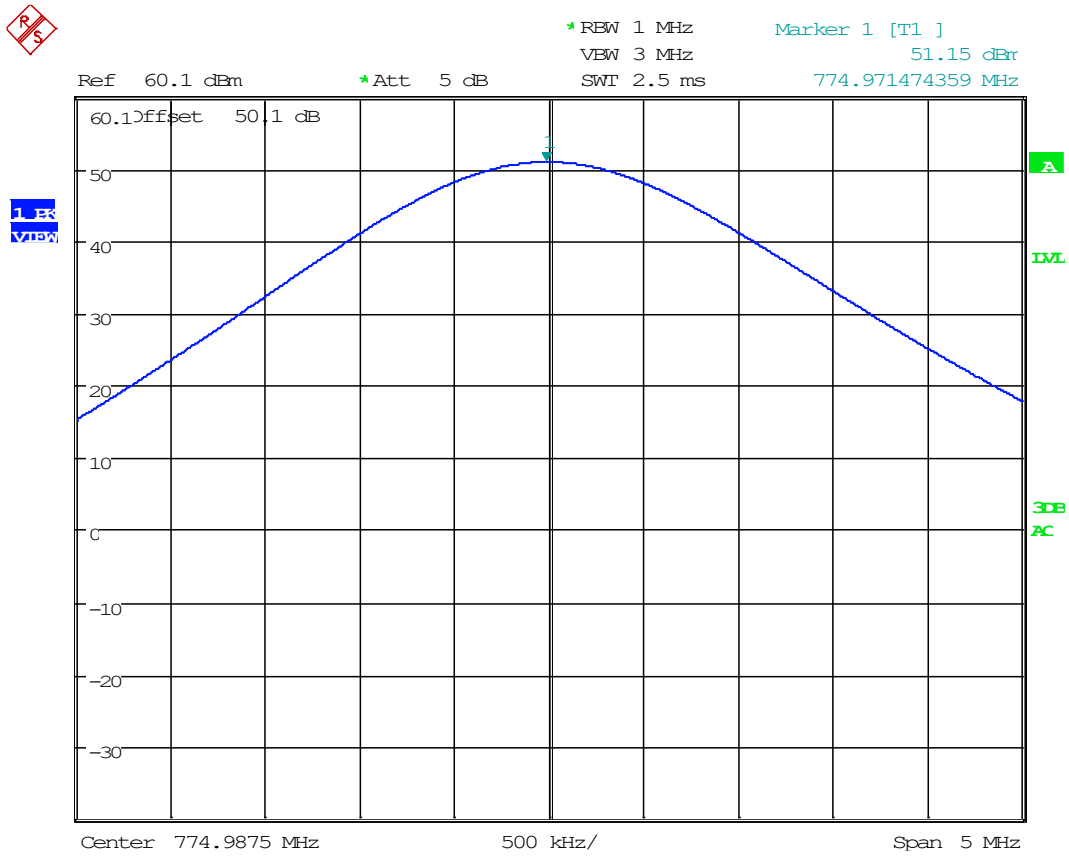

Date: 11.NOV.2020 17:26:23



### 8.2.3 Power Output, 804.9875 MHz

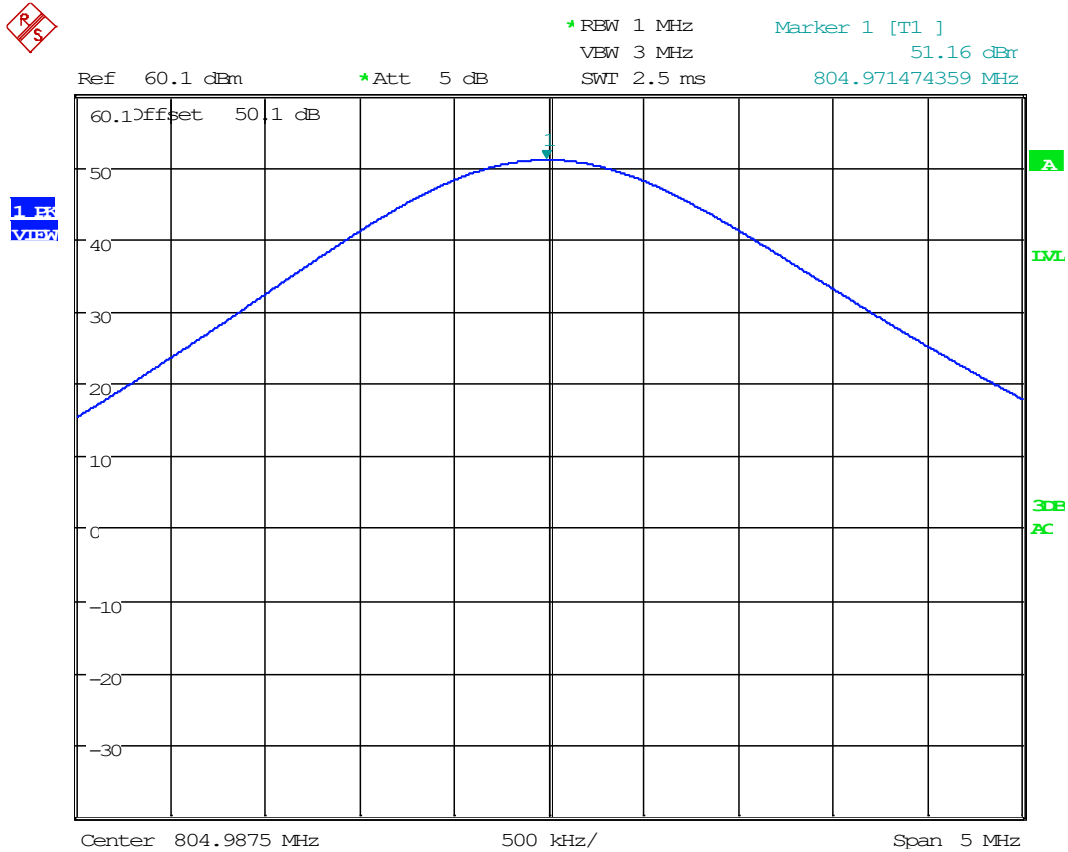

Date: 11.NOV.2020 17:19:49

### 8.2.4 Power Output, 806.0125 MHz

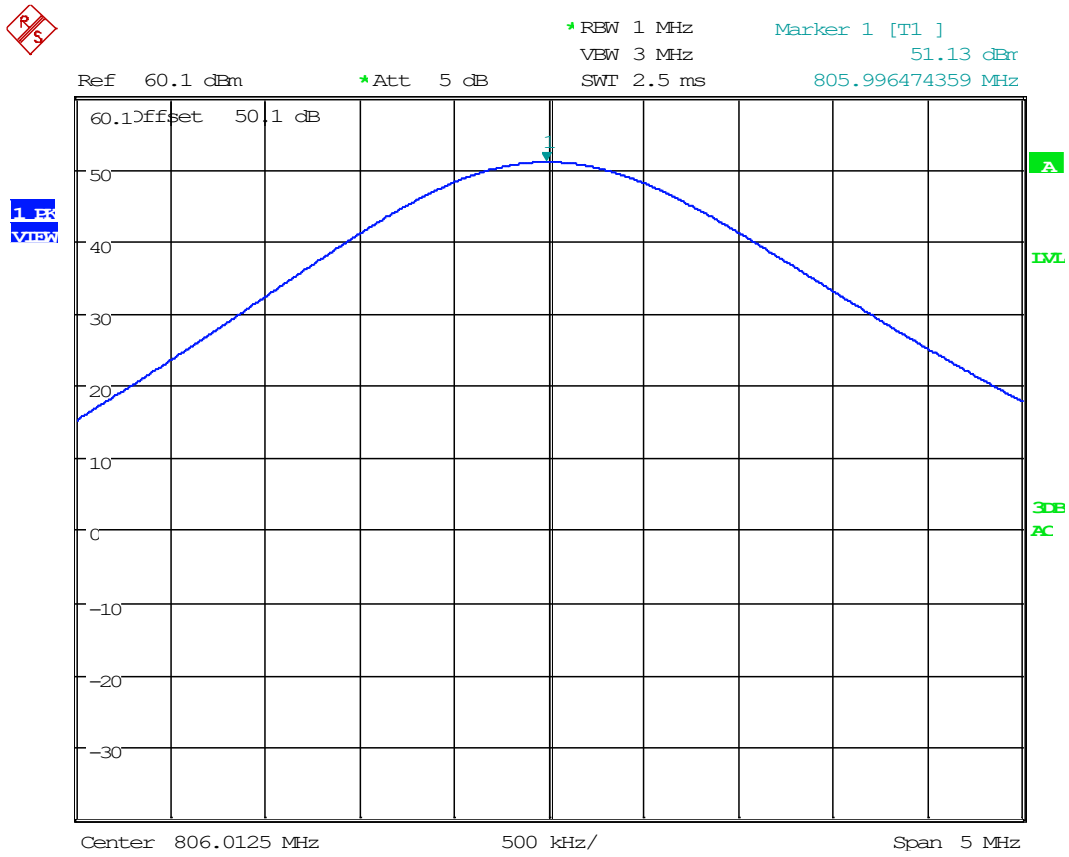

Date: 11.NOV.2020 17:22:17

### 8.2.5 Power Output, 823.9875 MHz

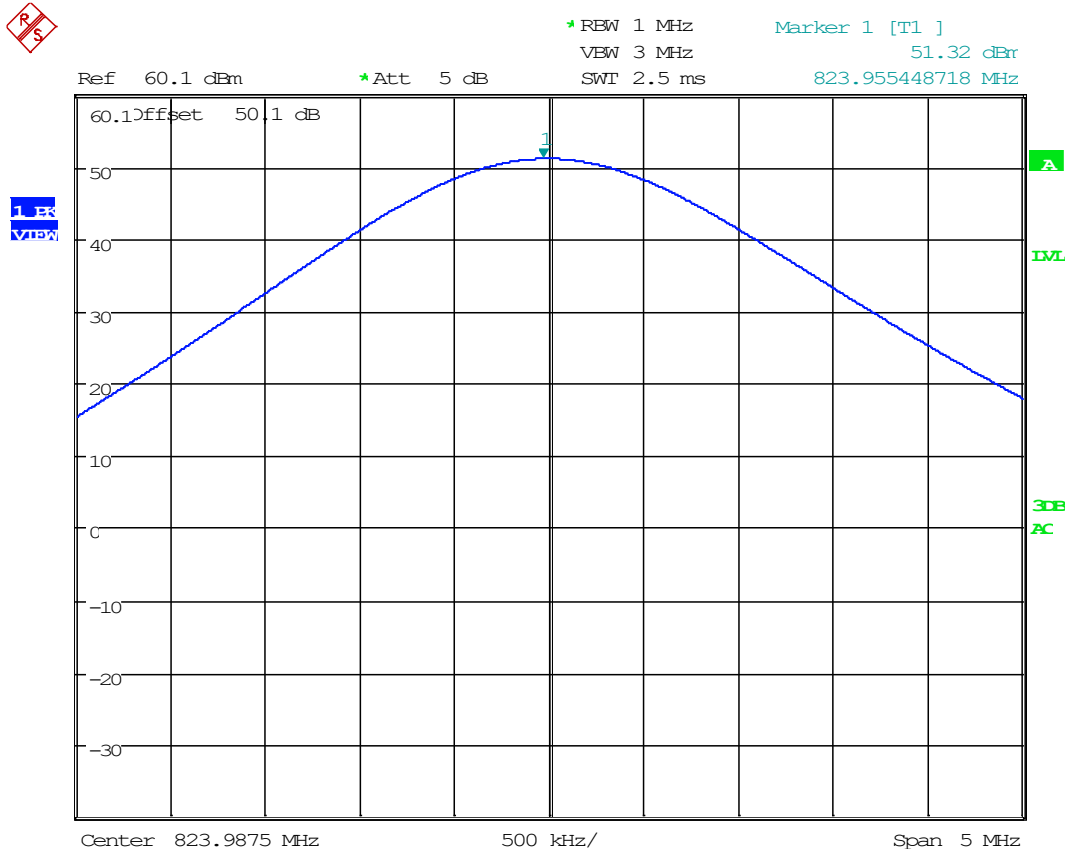

Date: 11.NOV.2020 17:27:18

### 8.2.6 Power Output, 851.0125 MHz

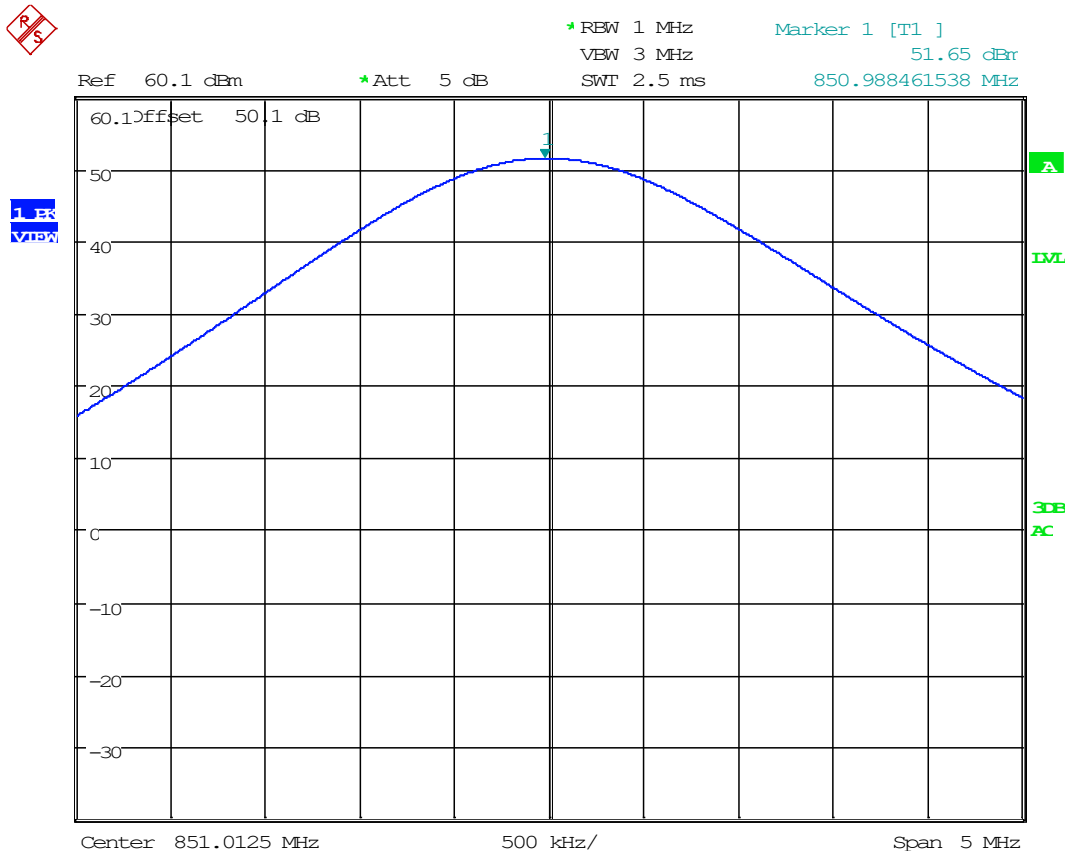

Date: 11.NOV.2020 17:23:31

### 8.2.7 Power Output, 868.9875 MHz

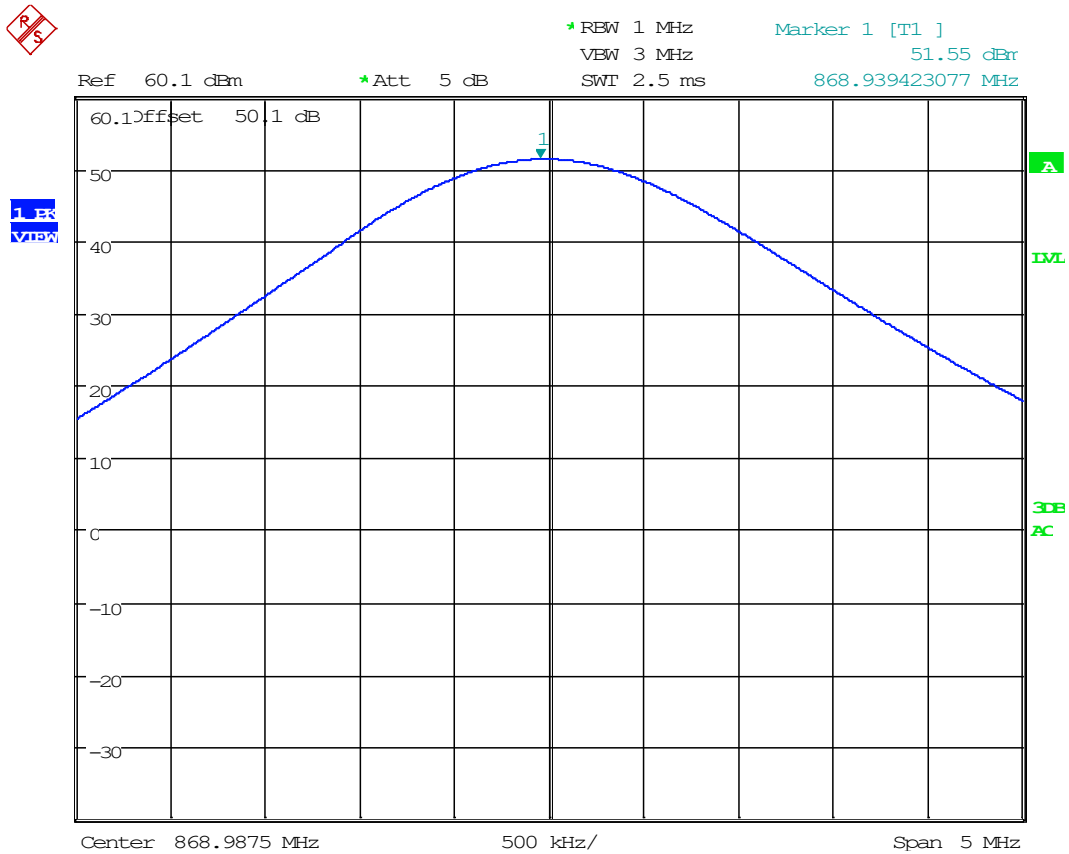

Date: 11.NOV.2020 17:25:06

### 8.3 Bandwidth & Emission

Limits from FCC Parts 2.1049, and 90.207 & 90.209, and test procedure from ANSI C63.26-2015.

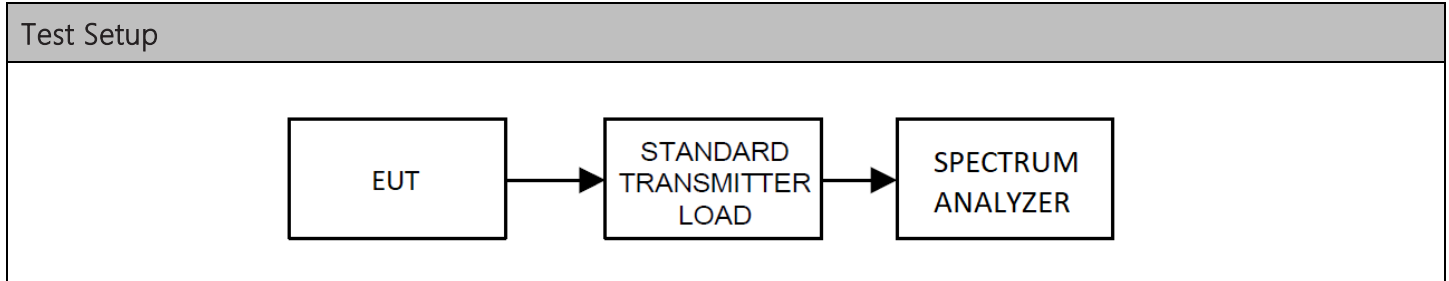

Test Results, Authorized Bandwidth		
Rule Part	Operating Range	Authorized Bandwidth
Part 90	762 – 870	12.5 kHz, 25 kHz

Test Results, Necessary Bandwidth			
Tuned Frequency (MHz)	Necessary Bandwidth (kHz)	Emission Designator	Bandwidth Type
774.9875	9.92	11K0F3E	99%
	14.93	16K0F3E	99%
	7.52	8K10F1E/F1D	99%
	7.79	7K80FXE/FXD/FXW	99%
823.9875	9.95	11K0F3E	99%
	14.93	16K0F3E	99%
	7.50	8K10F1E/F1D	99%
	7.39	7K80FXE/FXD/FXW	99%

Occupied Bandwidth, Spectrum Plots, 700 MHz Band

8.3.1 Bandwidth Plot, 99%, 11K0F3E, 774.9875 MHz

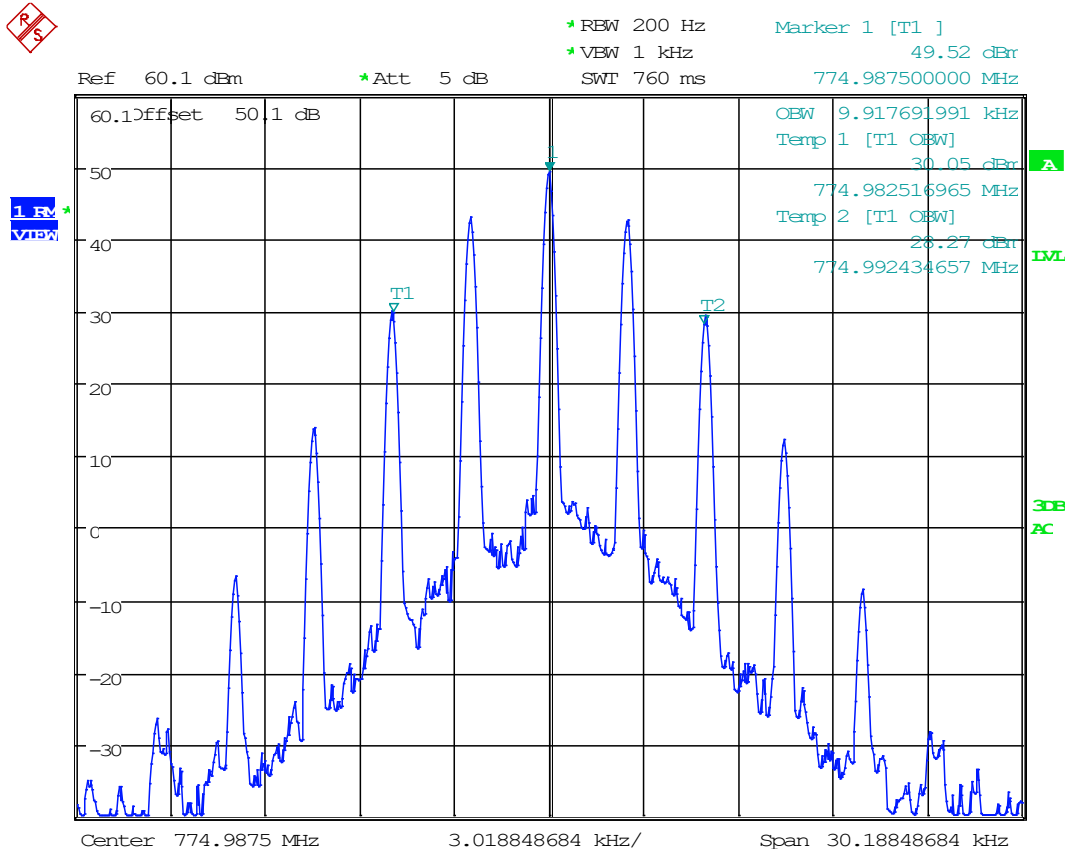

Date: 11.NOV.2020 18:03:05



### 8.3.1 Bandwidth Plot, 99%, 16K0F3E, 774.9875 MHz

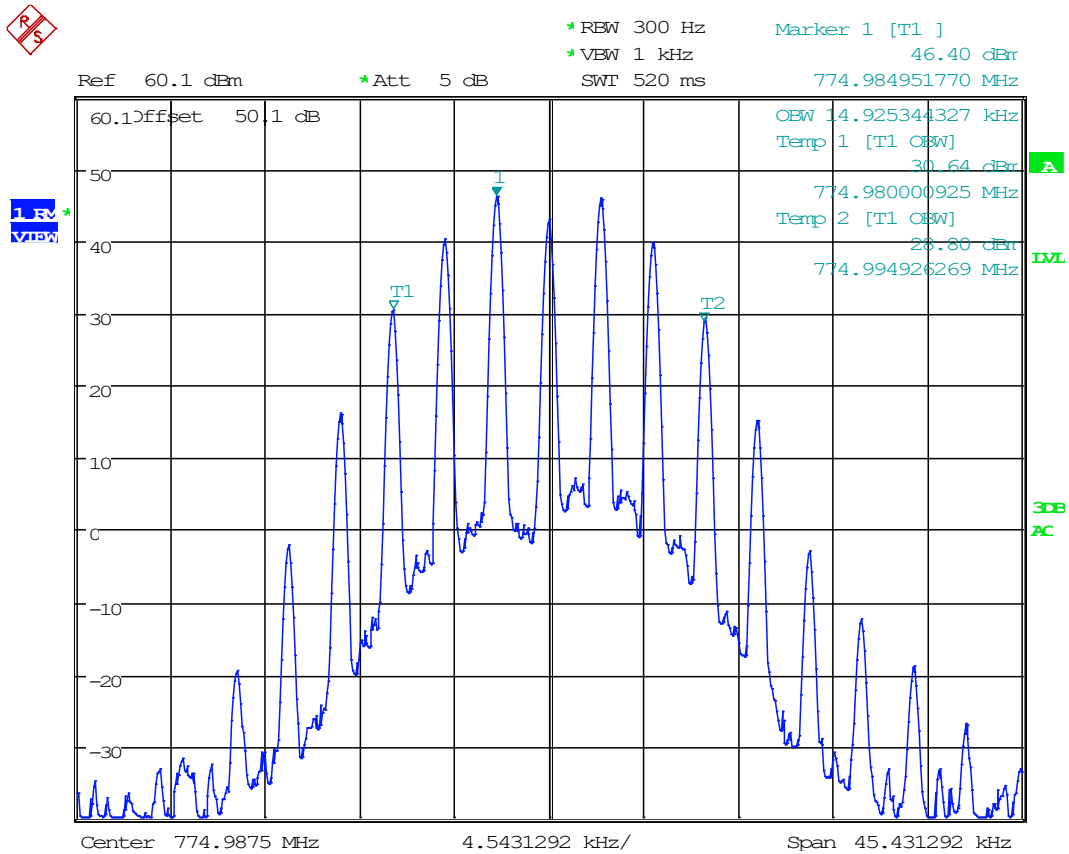

Date: 11.NOV.2020 17:58:45

### 8.3.1 Bandwidth Plot, 99%, 8K10F1E/F1D, 774.9875 MHz

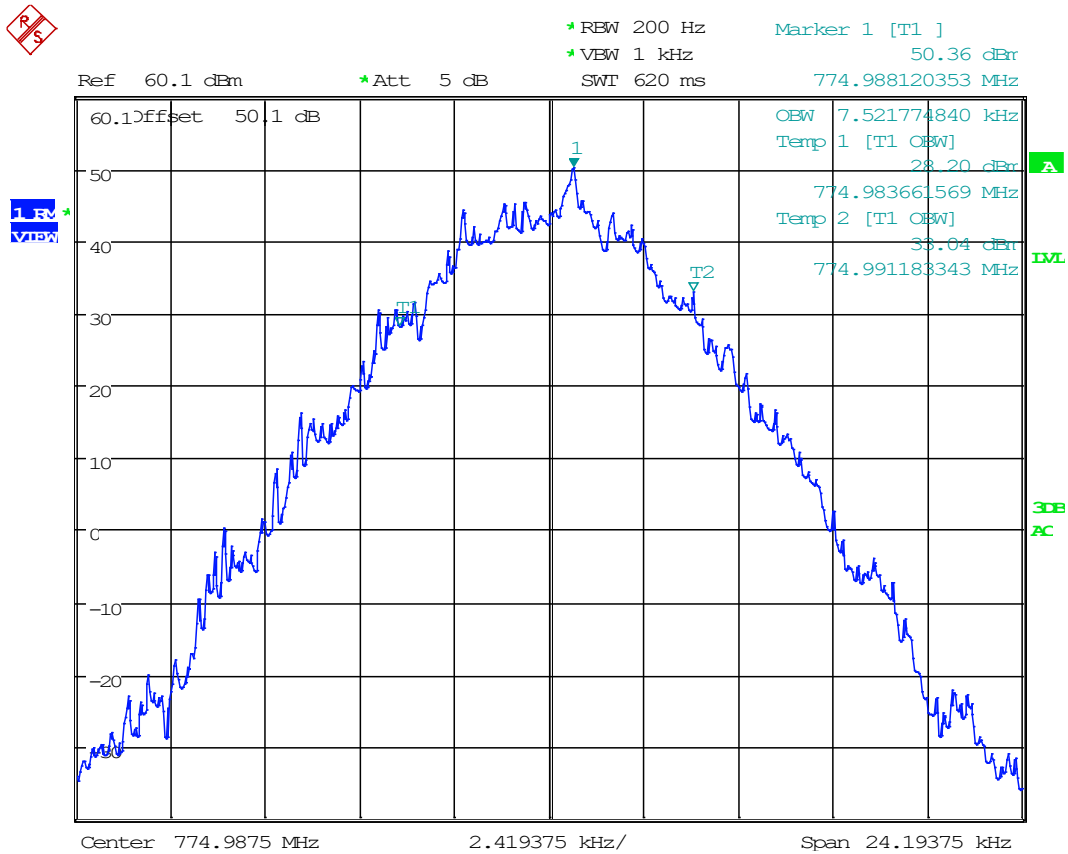

Date: 11.NOV.2020 18:04:57

### 8.3.1 Bandwidth Plot, 99%, 7K80FXE/FXD/FXW, 774.9875 MHz

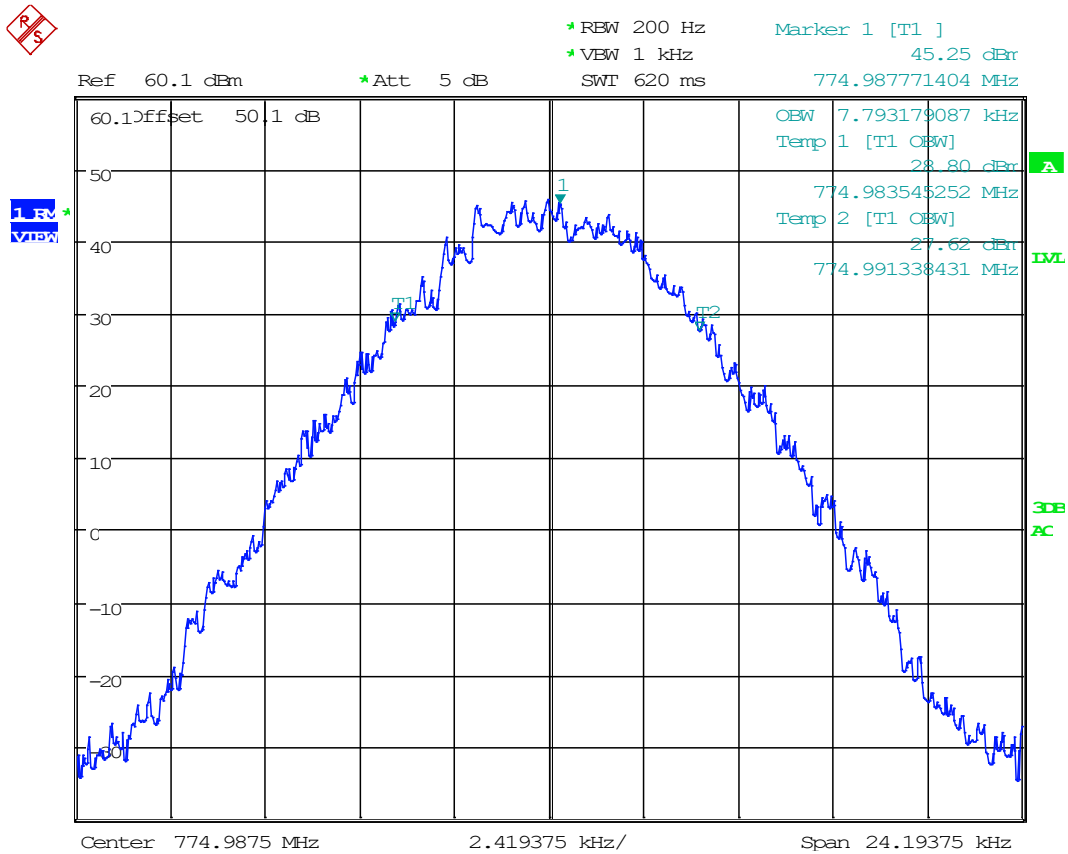

Date: 11.NOV.2020 18:05:54



Occupied Bandwidth, Spectrum Plots, 800 MHz Band

8.3.2 Bandwidth Plot, 99%, 11K0F3E, 823.9875 MHz

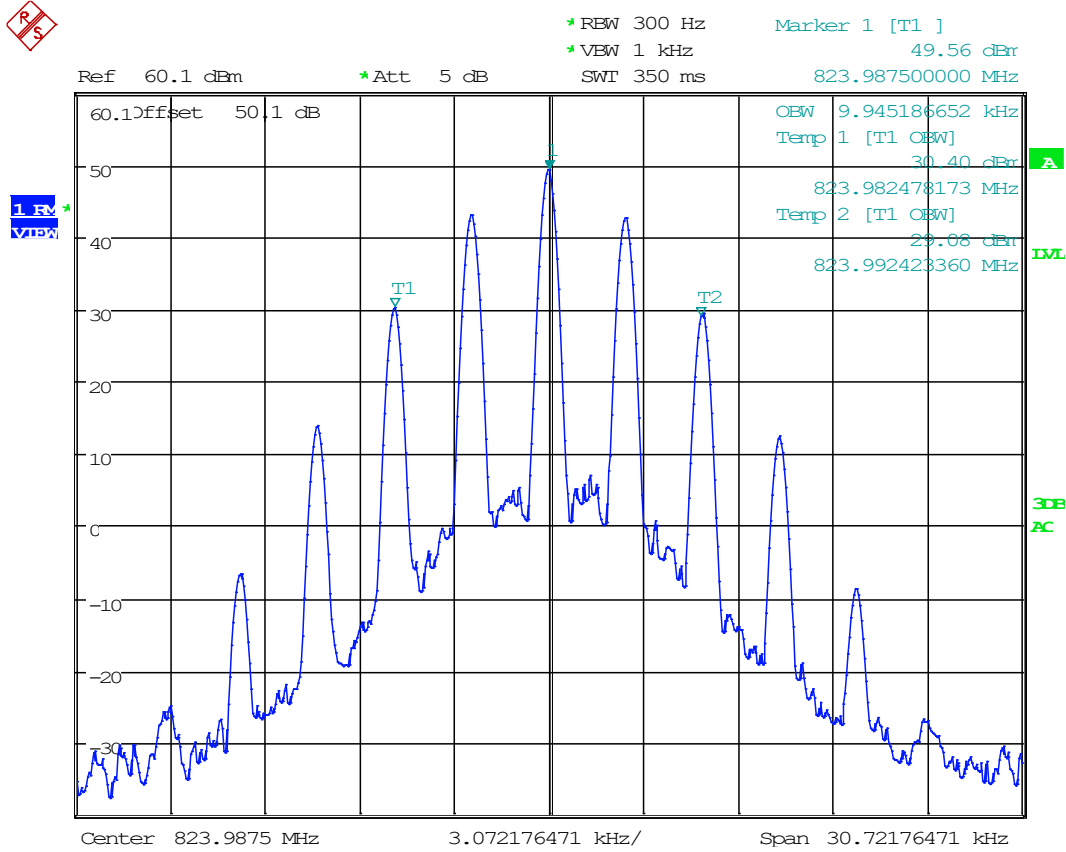

Date: 11.NOV.2020 17:51:46

### 8.3.1 Bandwidth Plot, 99%, 16K0F3E, 823.9875 MHz

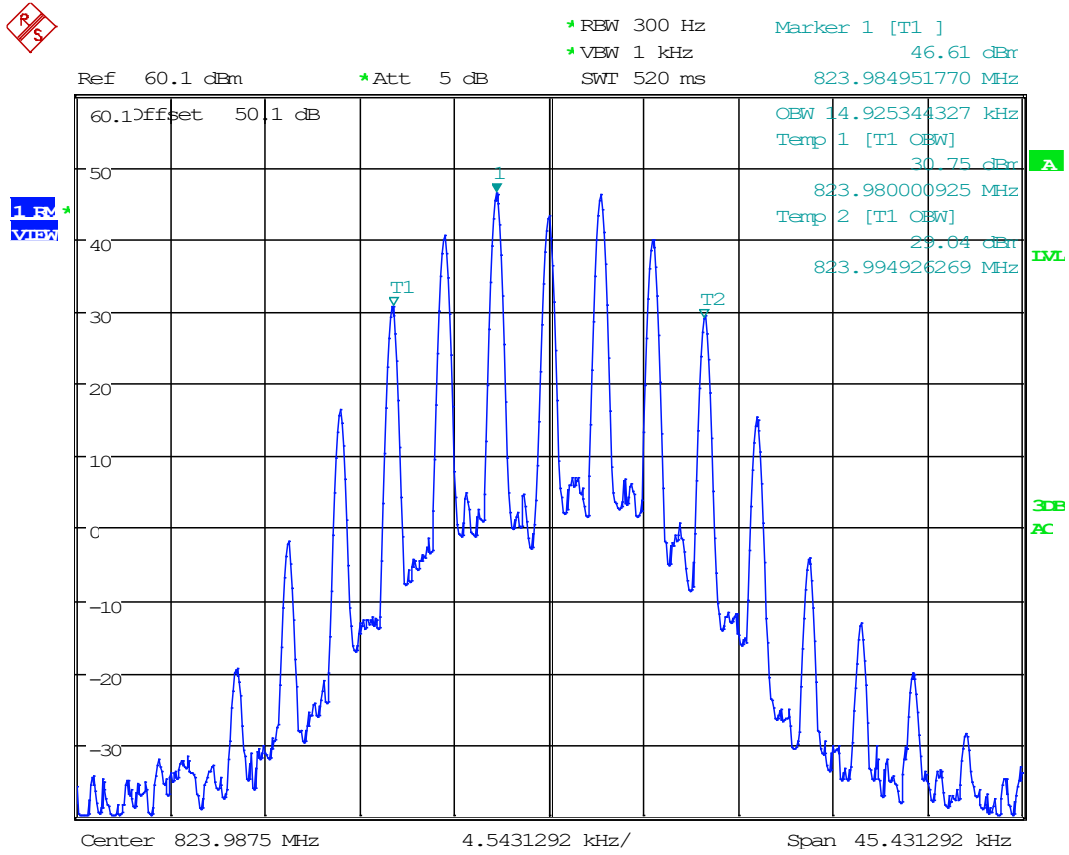

Date: 11.NOV.2020 17:57:02

### 8.3.2 Bandwidth Plot, 99%, 8K10F1E/F1D, 823.9875 MHz

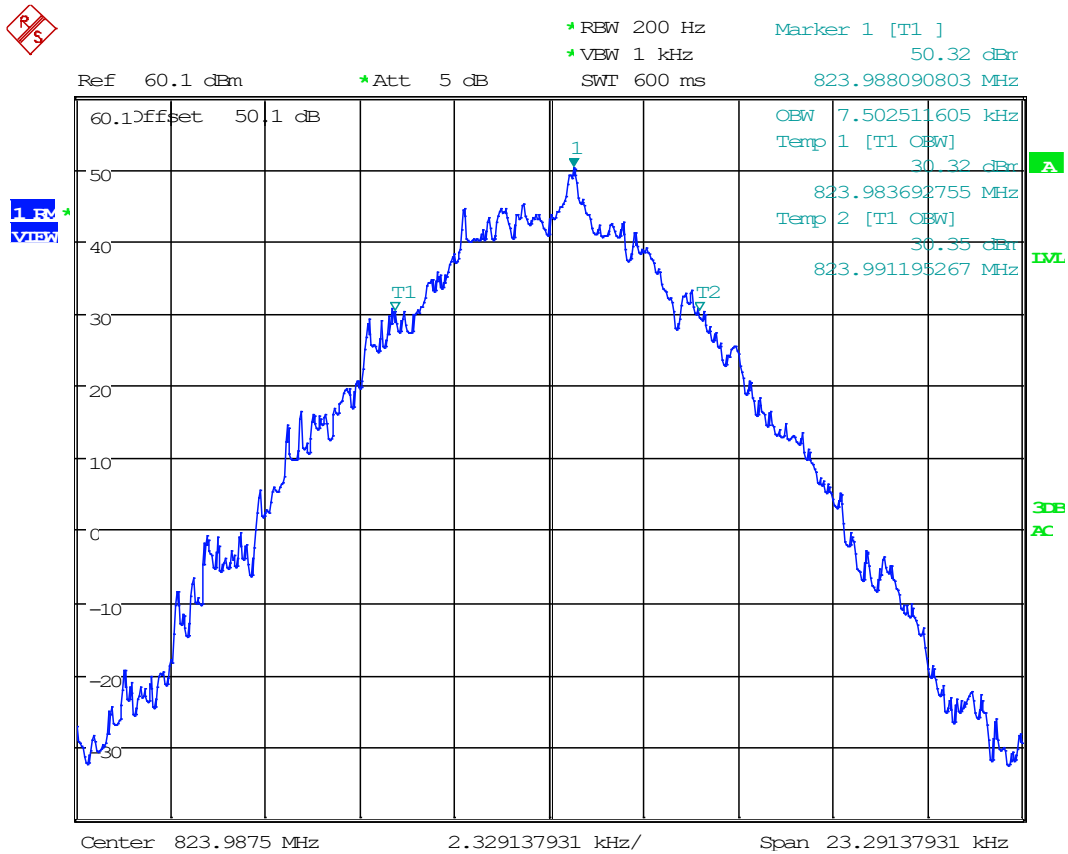

Date: 11.NOV.2020 17:53:53

### 8.3.3 Bandwidth Plot, 99%, 7K80FXE/FXD/FXW, 823.9875 MHz

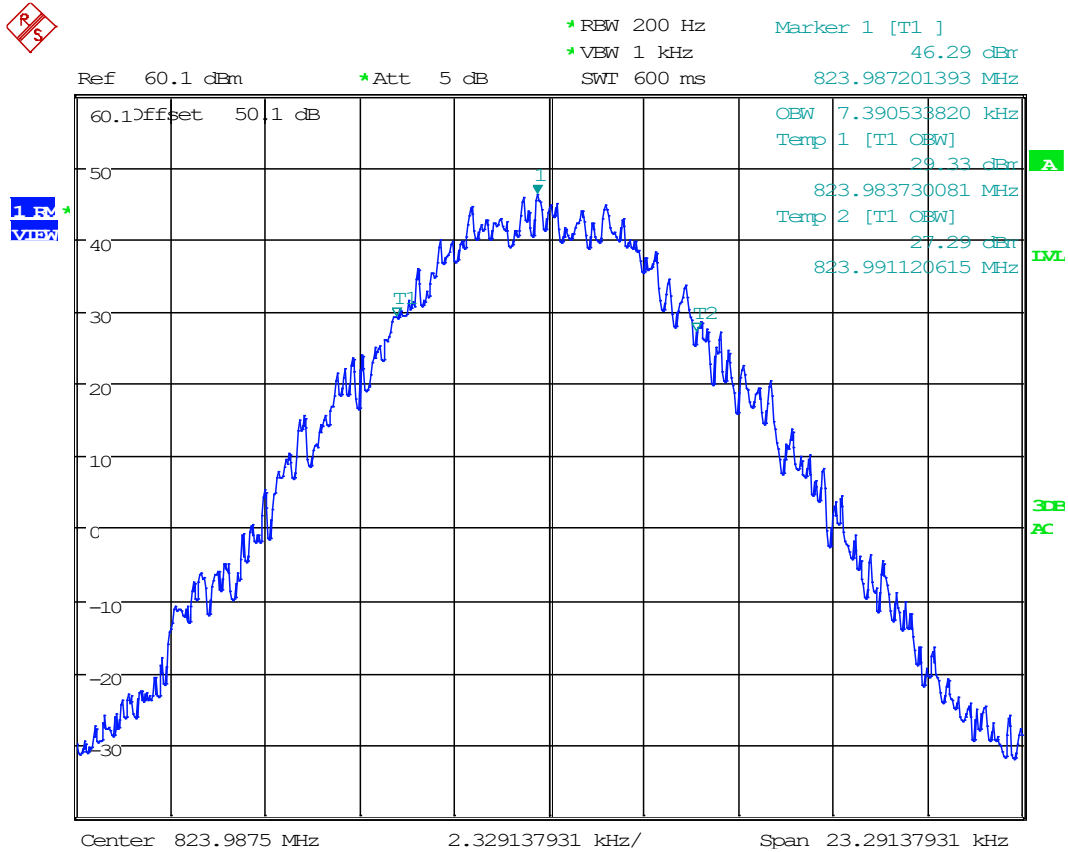

Date: 11.NOV.2020 17:55:05

## Necessary Bandwidth, Spectrum Plots

### 8.4 Emission Limitations, In-Band

Limits from FCC Part 90.210; and test procedure from ANSI C63.26-2015.

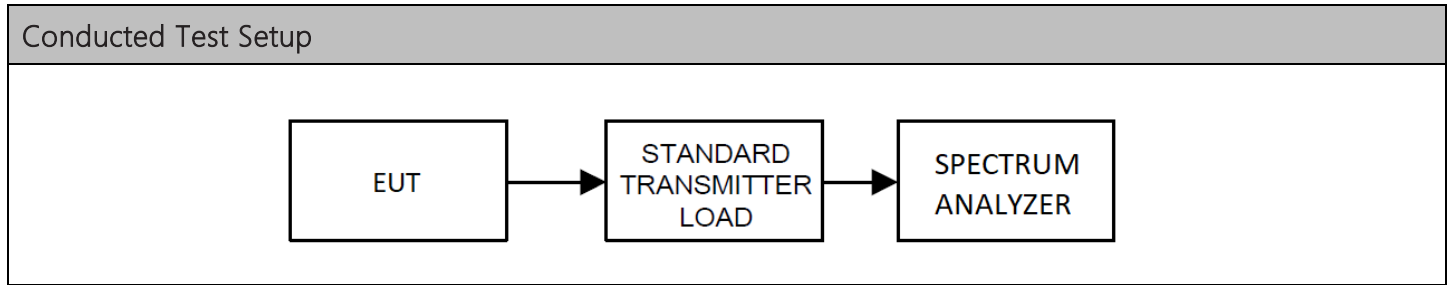

FCC CFR 47 Part 90 Emission Masks						
Frequency Band (MHz)	Mask for equipment with audio low pass filter			Mask for equipment without audio low pass filter		
	6.25 kHz	12.5 kHz	25 kHz	6.25 kHz	12.5 kHz	25 kHz
806 - 809	B, 20 kHz ABW			H, 20 kHz ABW		
809 - 817	D, 11.25 kHz ABW		B, 20 kHz ABW	D, 11.25 kHz ABW		G, 20 kHz ABW
817 - 824	D, 20 kHz ABW		B, 20 kHz ABW	D, 20 kHz ABW		G, 20 kHz ABW
851 - 854	B, 20 kHz ABW			H, 20 kHz ABW		
854 - 862	D, 11.25 kHz ABW		B, 20 kHz ABW	D, 11.25 kHz ABW		G, 20 kHz ABW
862 - 869	D, 20 kHz ABW		B, 20 kHz ABW	D, 20 kHz ABW		G, 20 kHz ABW
All other bands	B			C		



Conducted Emissions Mask, Spectrum Plots, 700 Band

8.4.1 Emission Mask, 11K0F3E, 763.0125 MHz

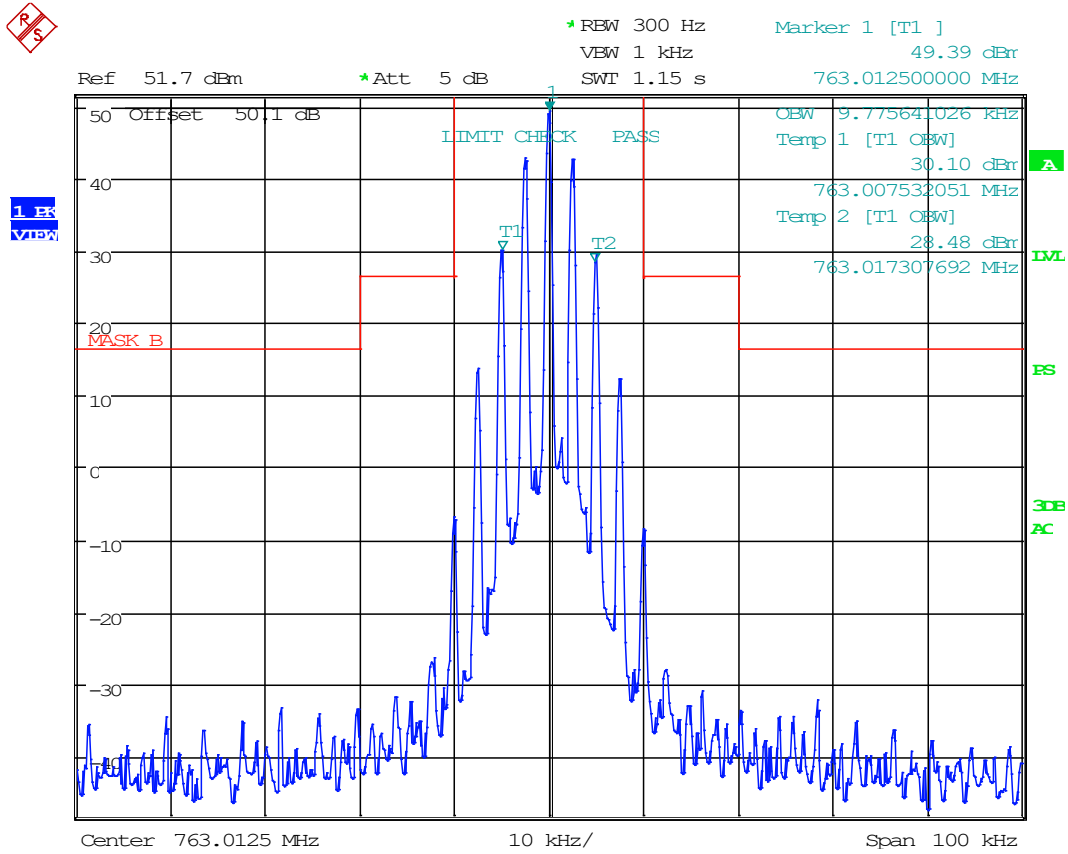

Date: 12.NOV.2020 13:16:14

### 8.4.1 Emission Mask, 16K0F3E, 763.0125 MHz

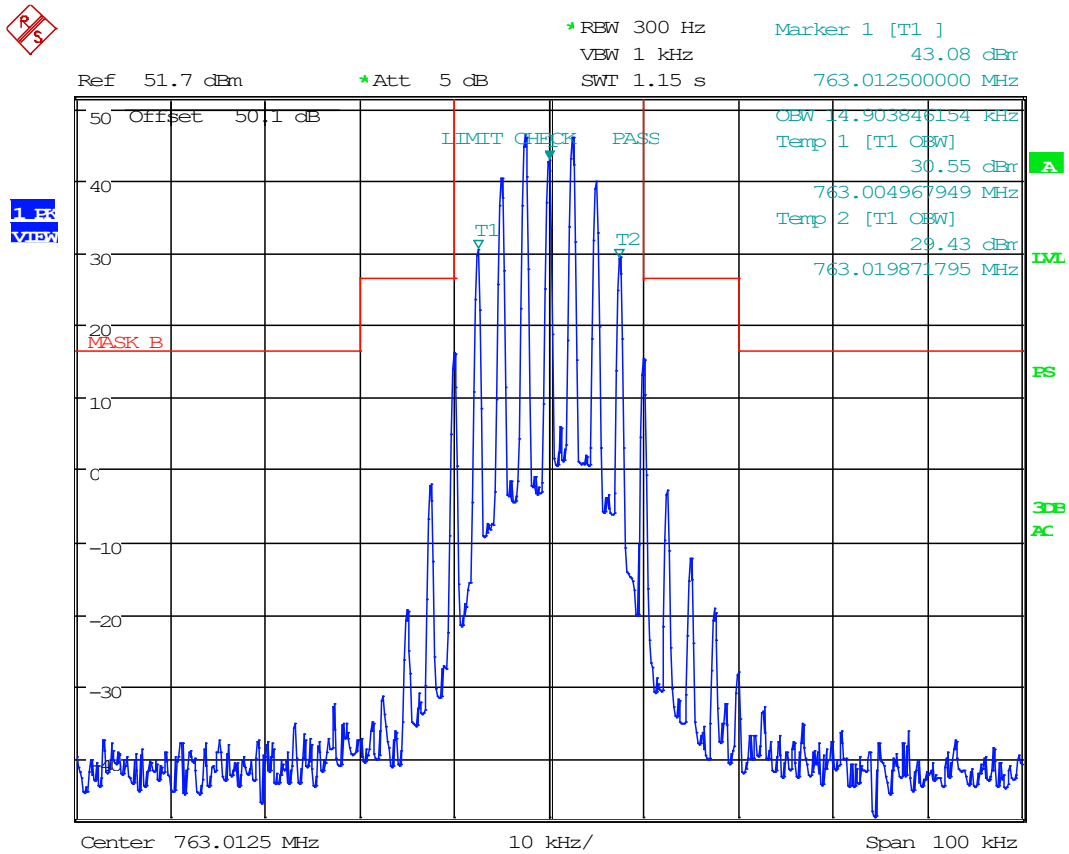

Date: 12.NOV.2020 13:17:15

### 8.4.1 Emission Mask, 8K10F1E/F1D, 763.0125 MHz

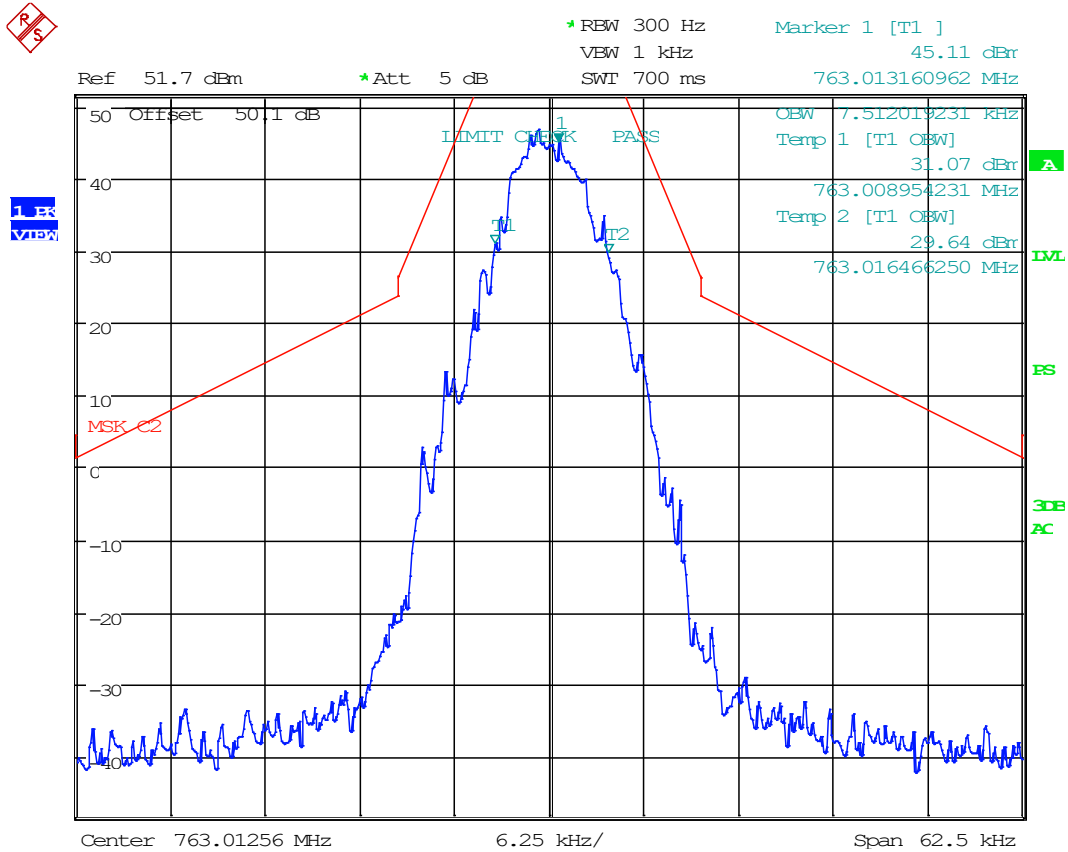

Date: 12.NOV.2020 13:05:46

### 8.4.1 Emission Mask, 7K80FXE/FXD/FXW, 763.0125 MHz

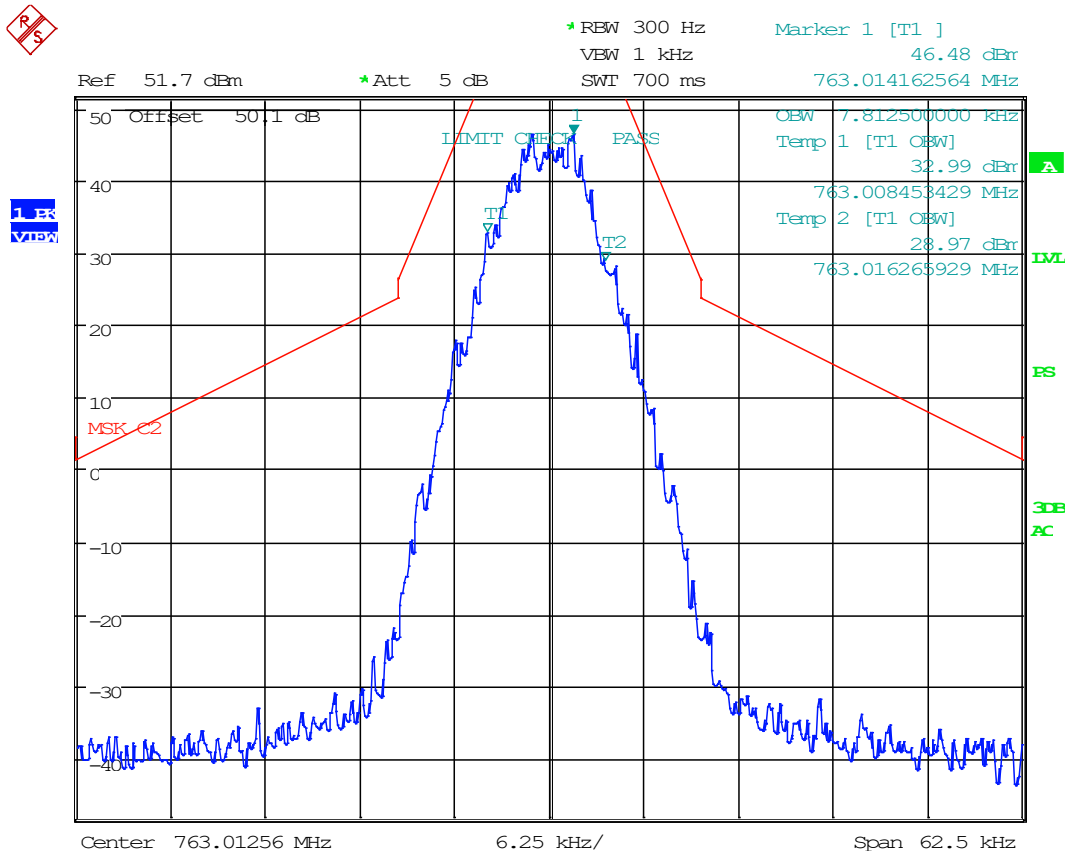

Date: 12.NOV.2020 13:06:49

### 8.4.2 Emission Mask, 11K0F3E, 774.9875 MHz

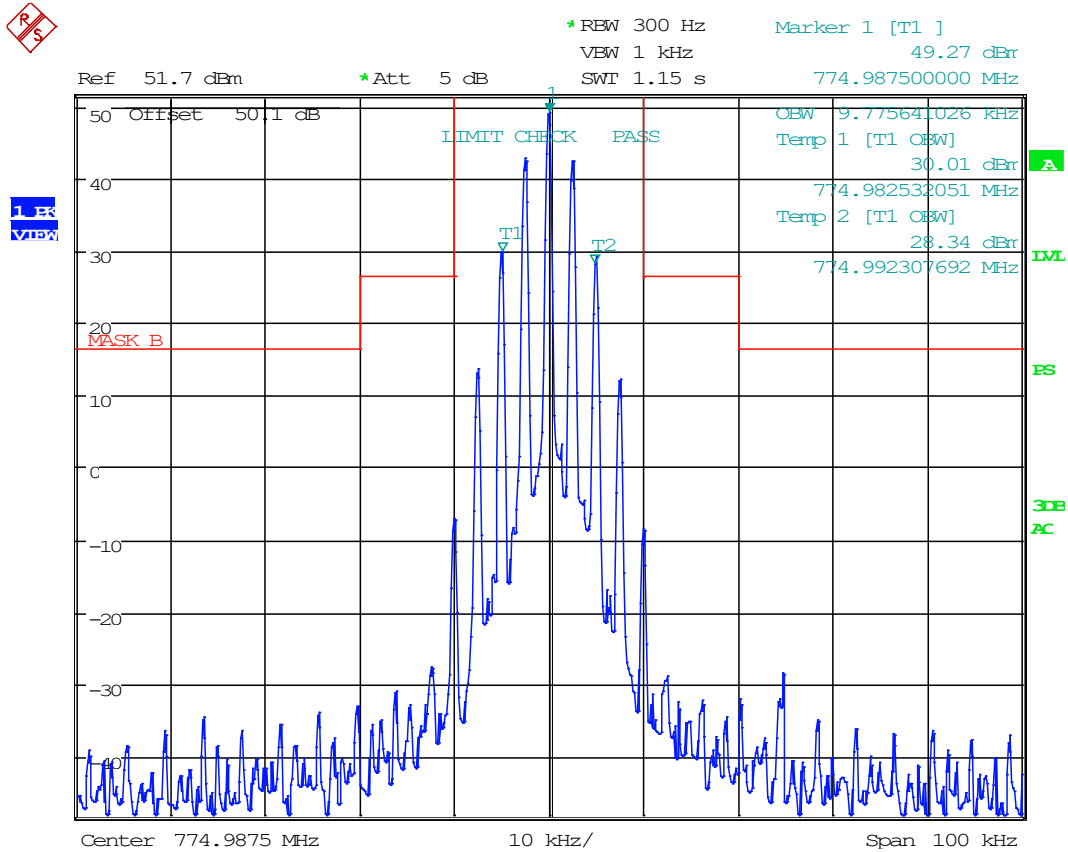

Date: 12.NOV.2020 13:12:52

### 8.4.3 Emission Mask, 16K0F3E, 774.9875 MHz

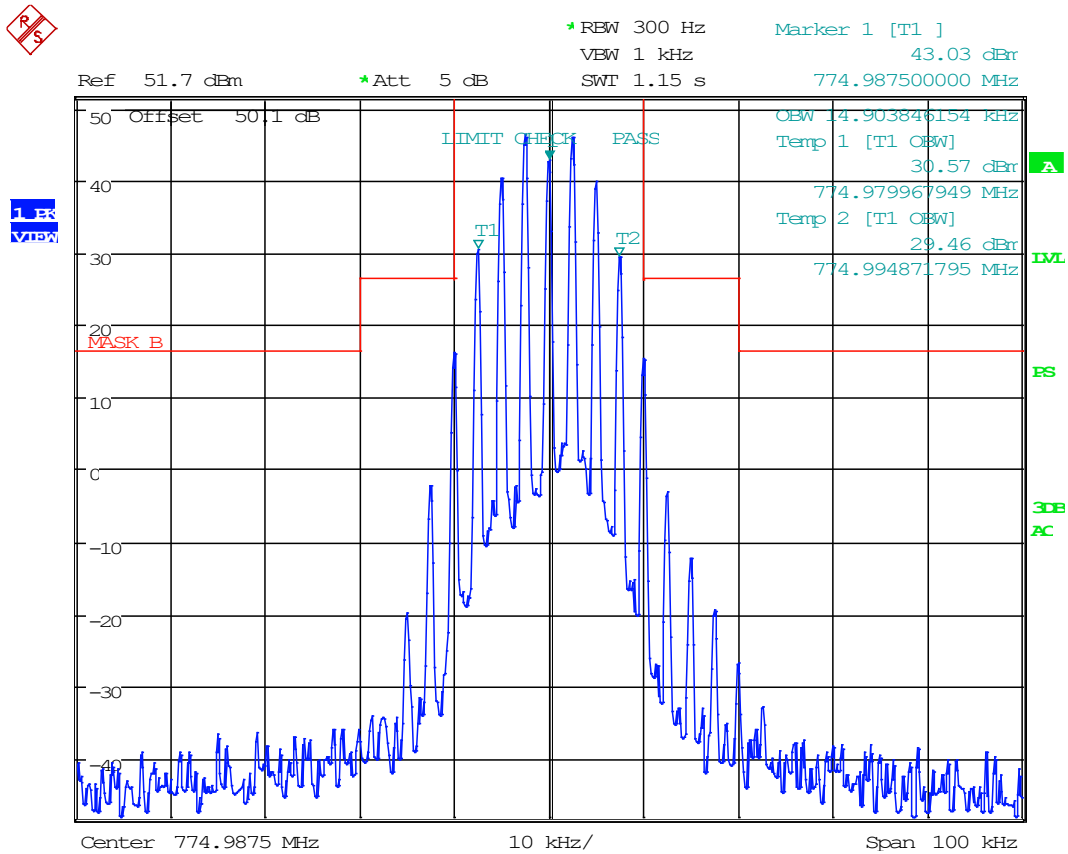

Date: 12.NOV.2020 13:13:35

### 8.4.4 Emission Mask, 8K10F1E/F1D, 774.9875 MHz

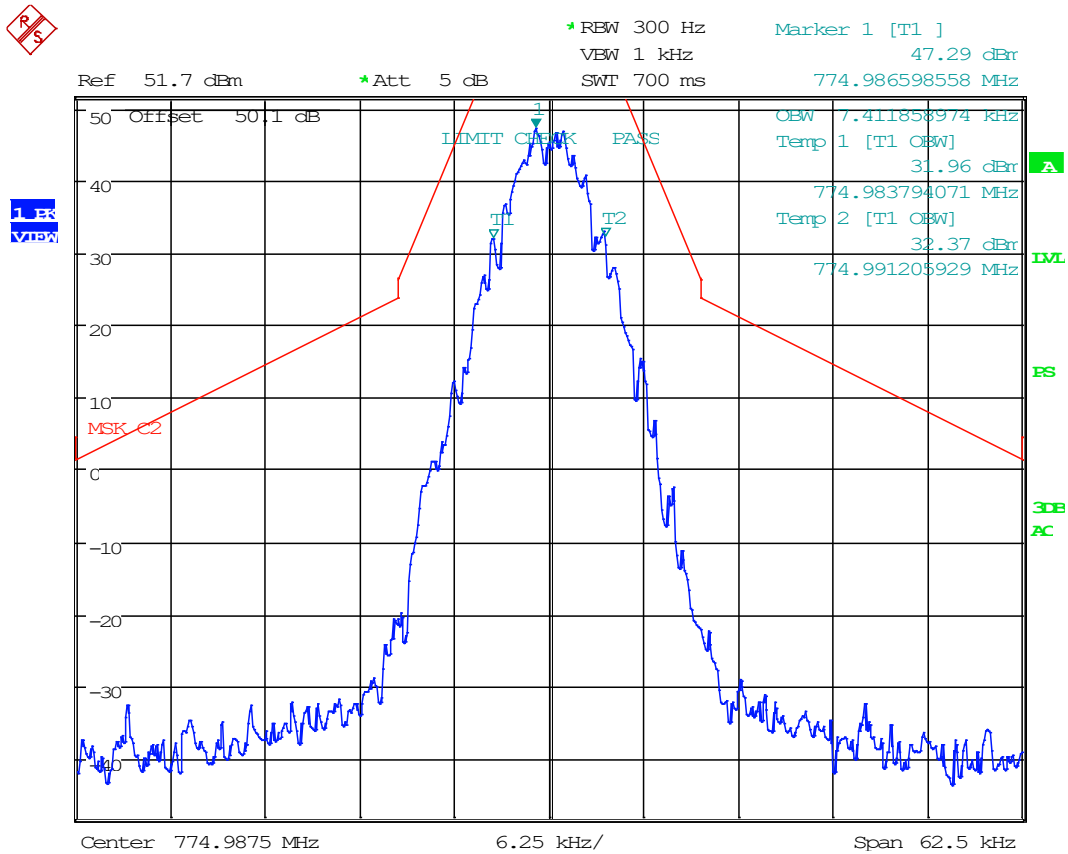

Date: 12.NOV.2020 13:09:30

### 8.4.5 Emission Mask, 7K80FXE/FXD/FXW, 774.9875 MHz

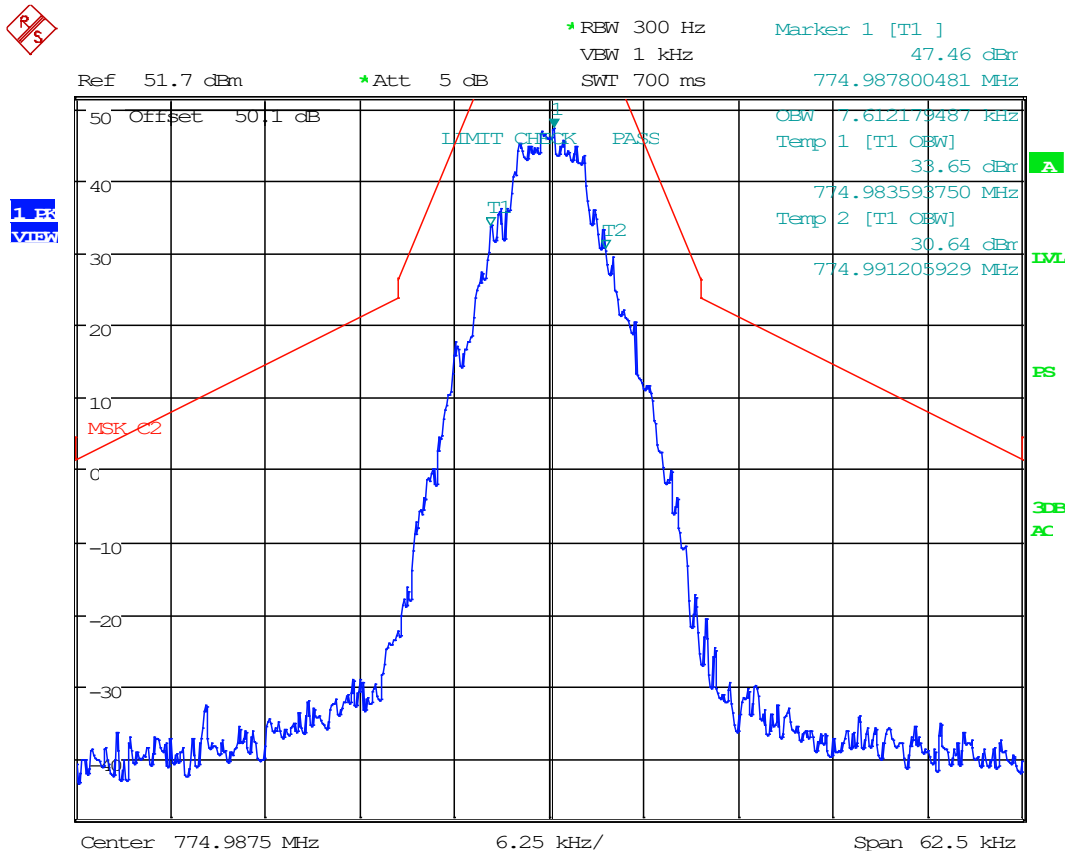

Date: 12.NOV.2020 13:10:05



### 8.4.6 Emission Mask, 11K0F3E, 804.9875 MHz

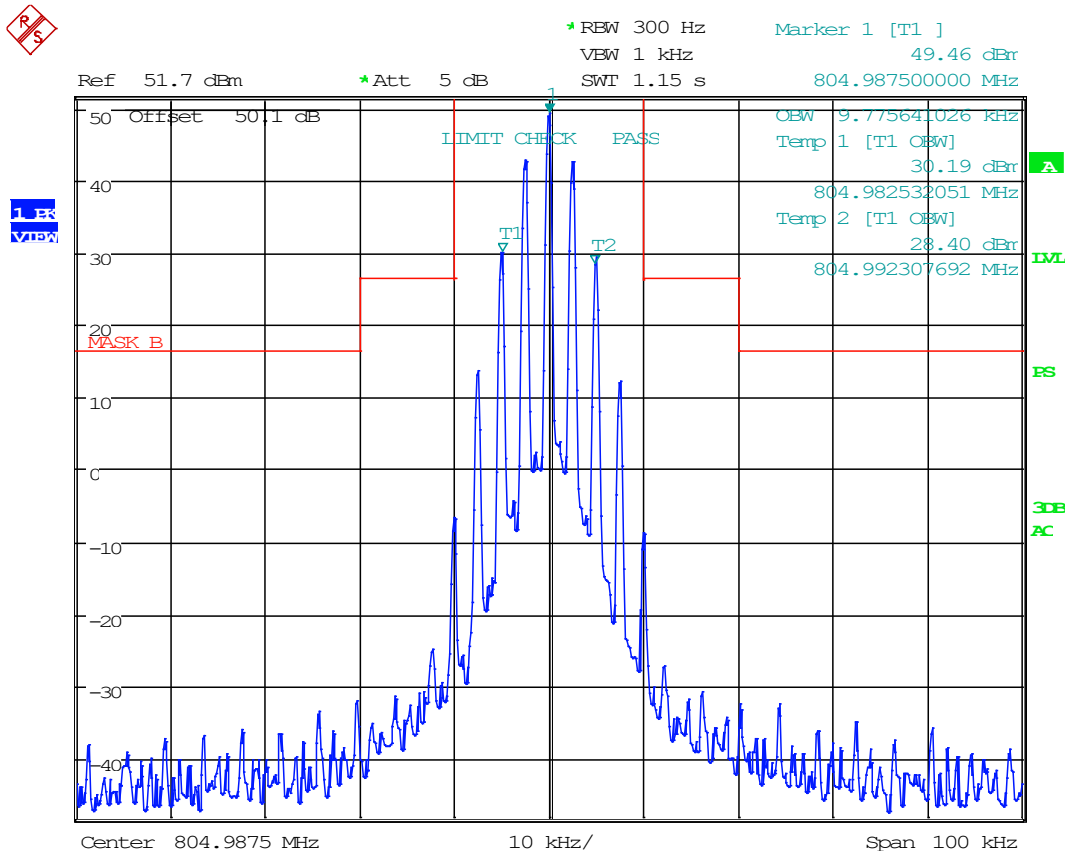

Date: 12.NOV.2020 13:15:13

### 8.4.7 Emission Mask, 16K0F3E, 804.0125 MHz

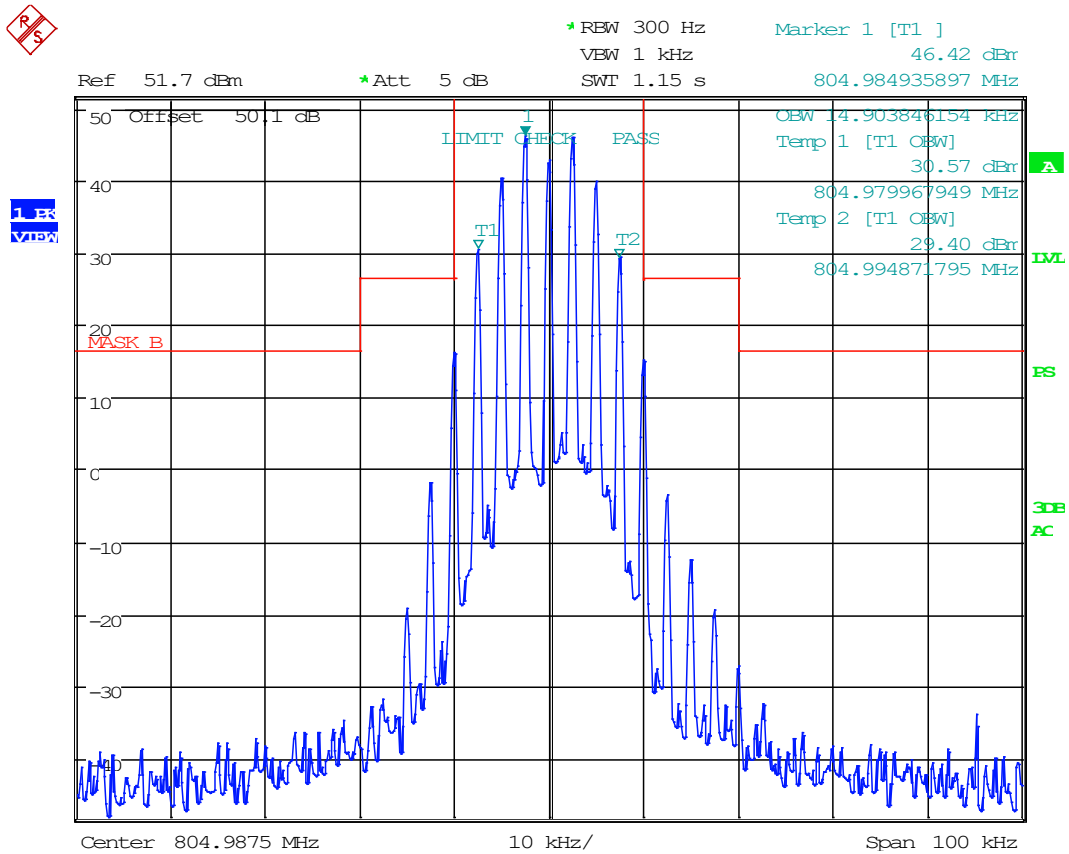

Date: 12.NOV.2020 13:14:34

### 8.4.8 Emission Mask, 8K10F1E/F1D, 804.0125 MHz

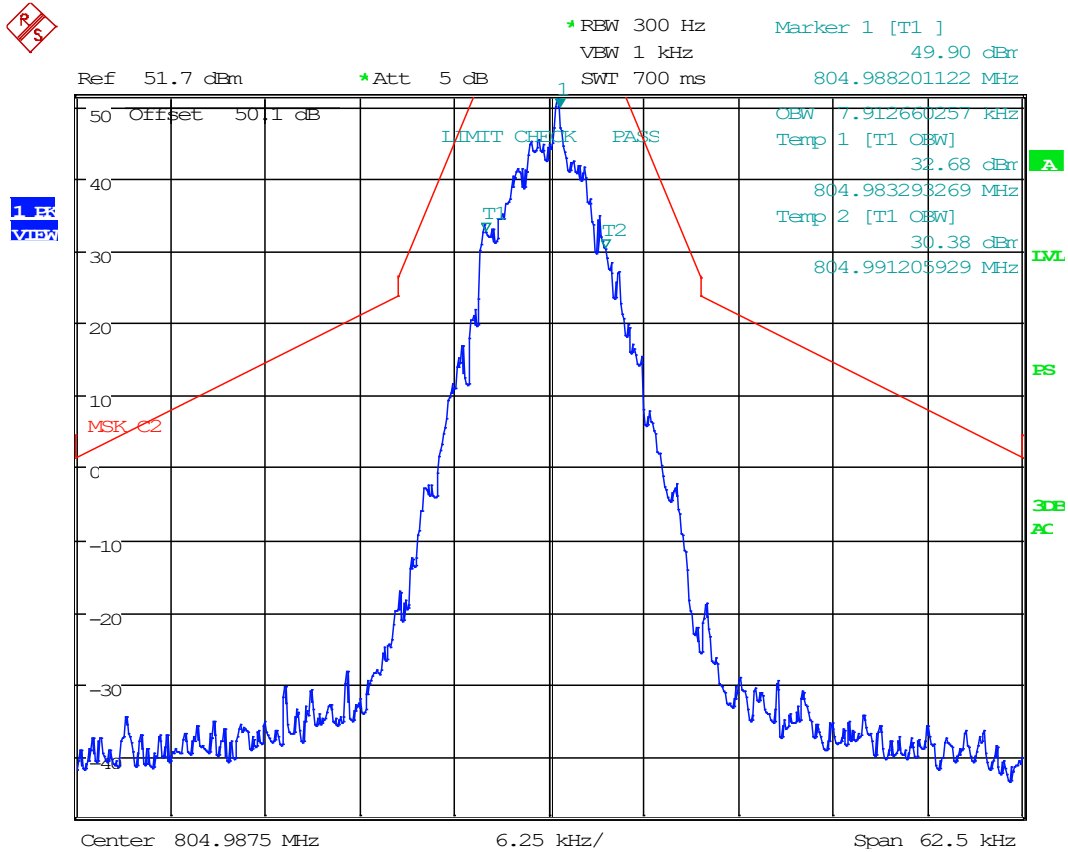

Date: 12.NOV.2020 13:07:51



Conducted Emissions Mask, Spectrum Plots, 800 Band

8.4.10 Emission Mask, 11K0F3E, 806.0125 MHz

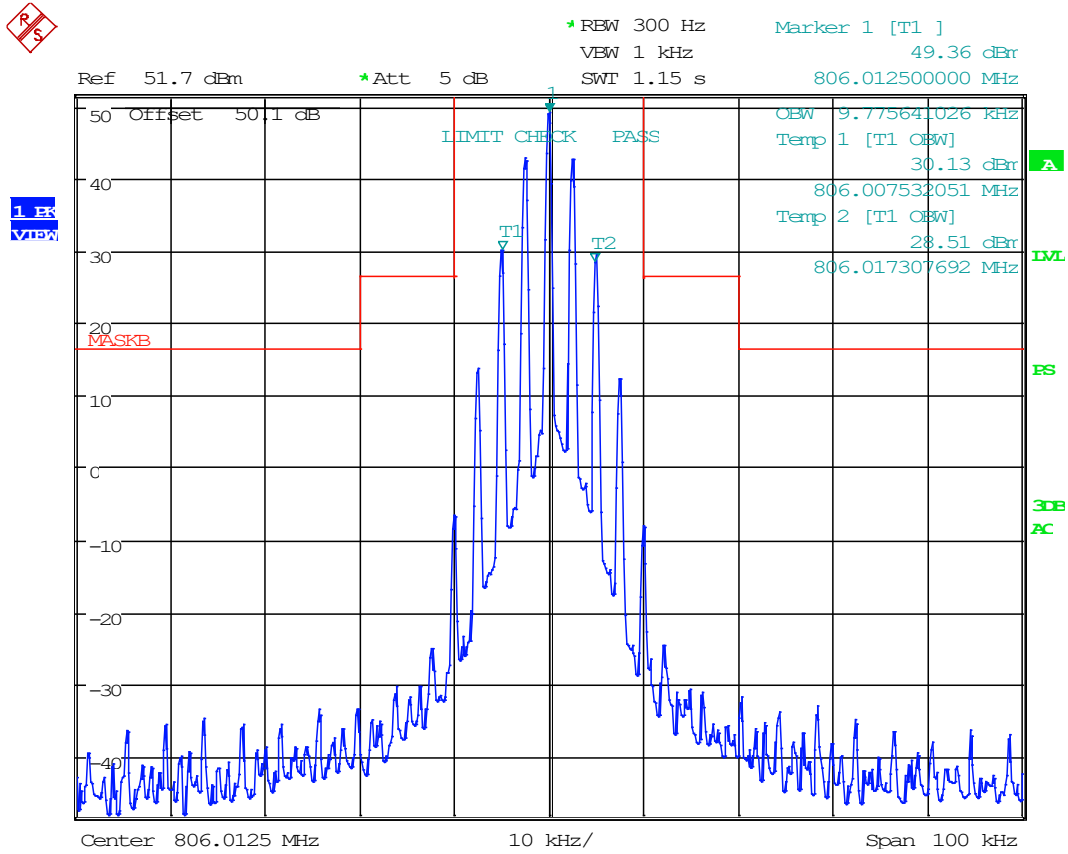

Date: 12.NOV.2020 13:24:09

### 8.4.11 Emission Mask, 16K0F3E, 806.0125 MHz

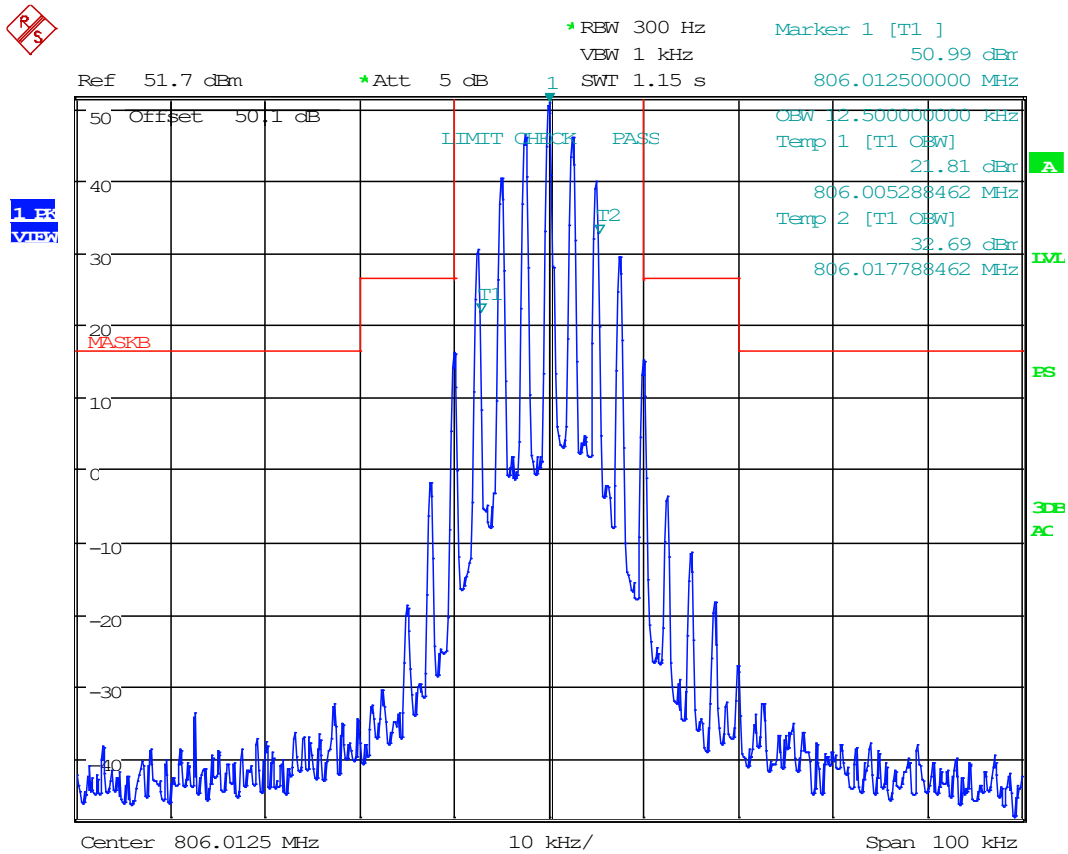

Date: 12.NOV.2020 13:25:06



### 8.4.13 Emission Mask, 7K80FXE/FXD/FXW, 806.0125 MHz

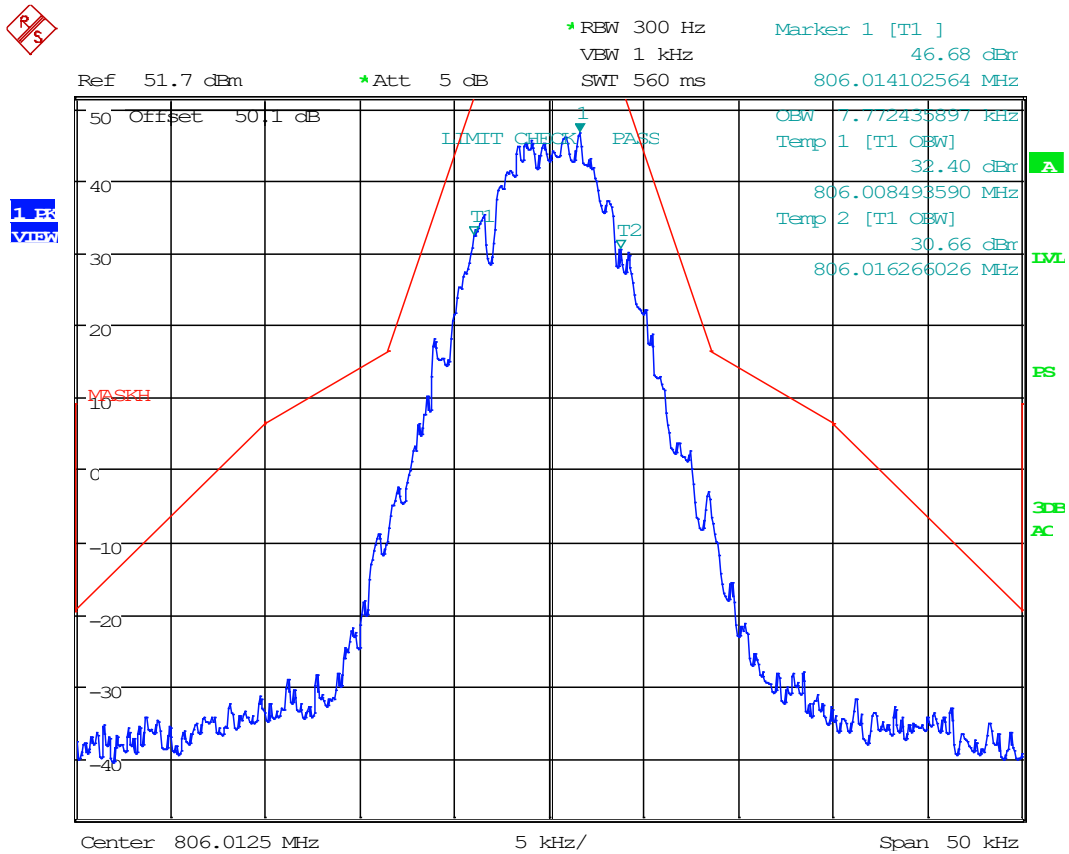

Date: 12.NOV.2020 13:32:19











### 8.4.18 Emission Mask, 11K0F3E, 851.0125 MHz

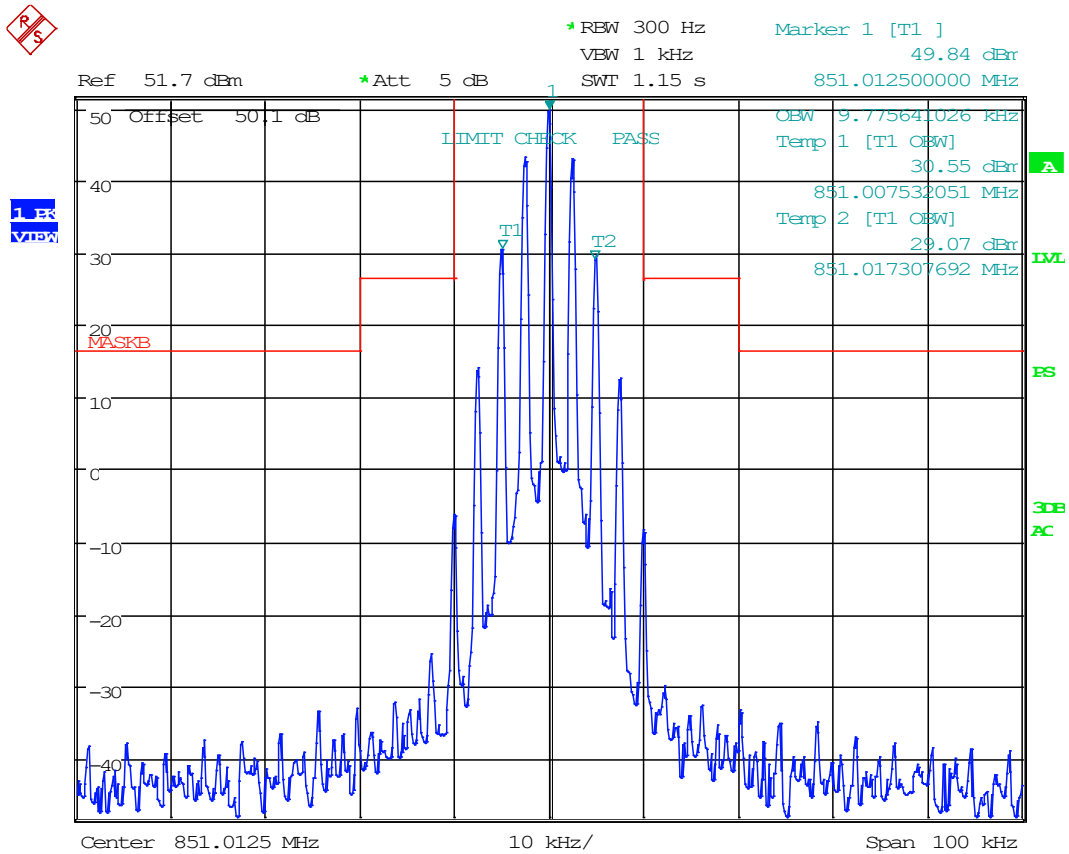

Date: 12.NOV.2020 13:26:40

### 8.4.19 Emission Mask, 16K0F3E, 851.0125 MHz

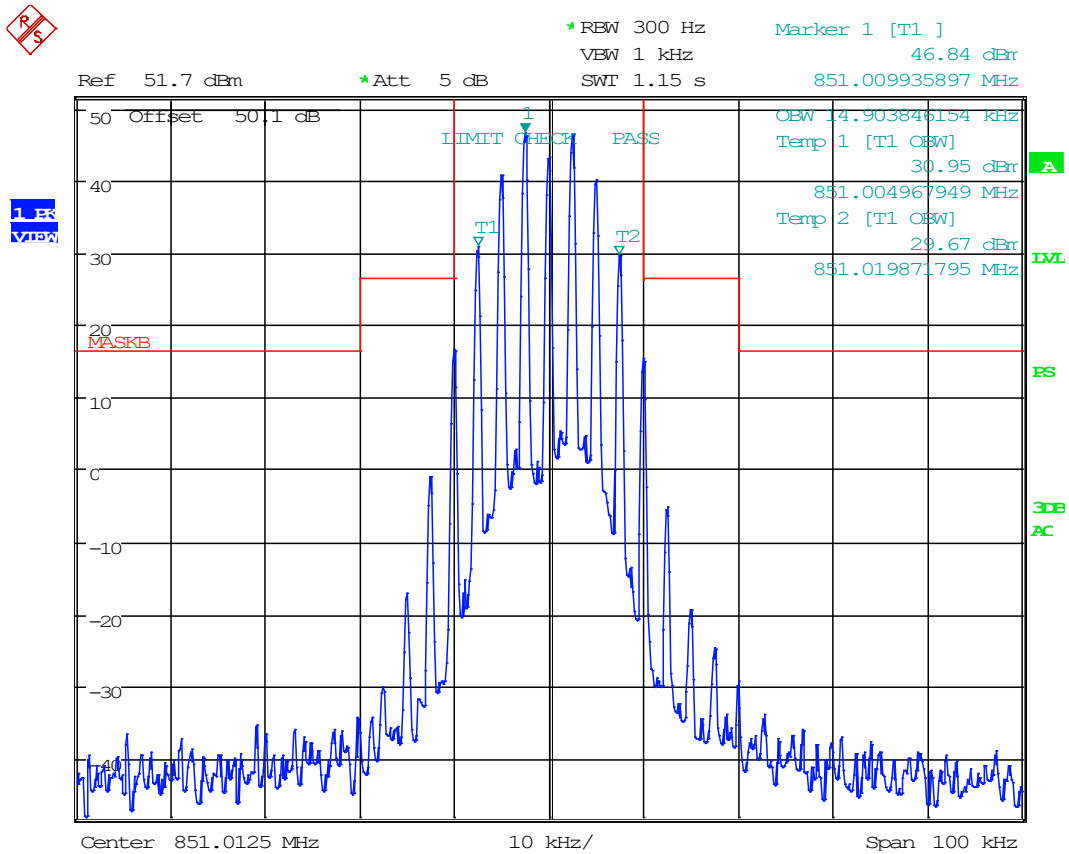

Date: 12.NOV.2020 13:25:57

### 8.4.20 Emission Mask, 8K10F1E/F1D, 851.0125 MHz

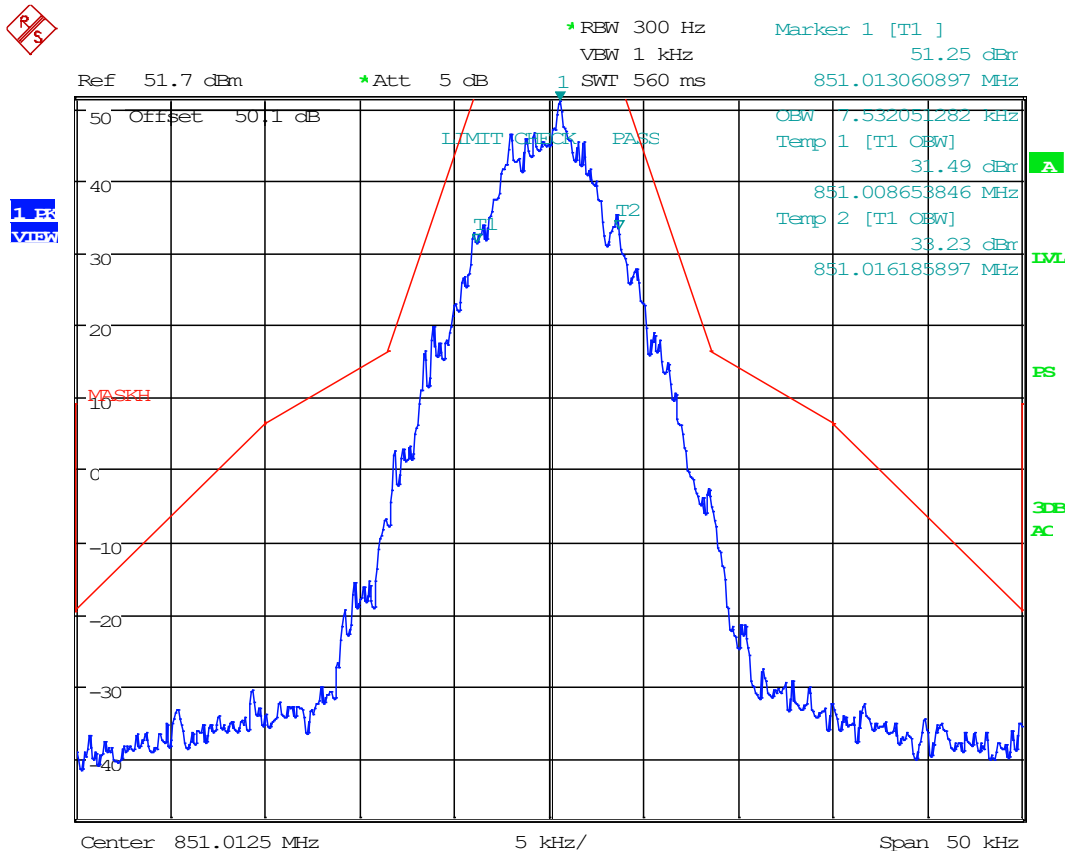

Date: 12.NOV.2020 13:33:15

### 8.4.21 Emission Mask, 7K80FXE/FXD/FXW, 851.0125 MHz

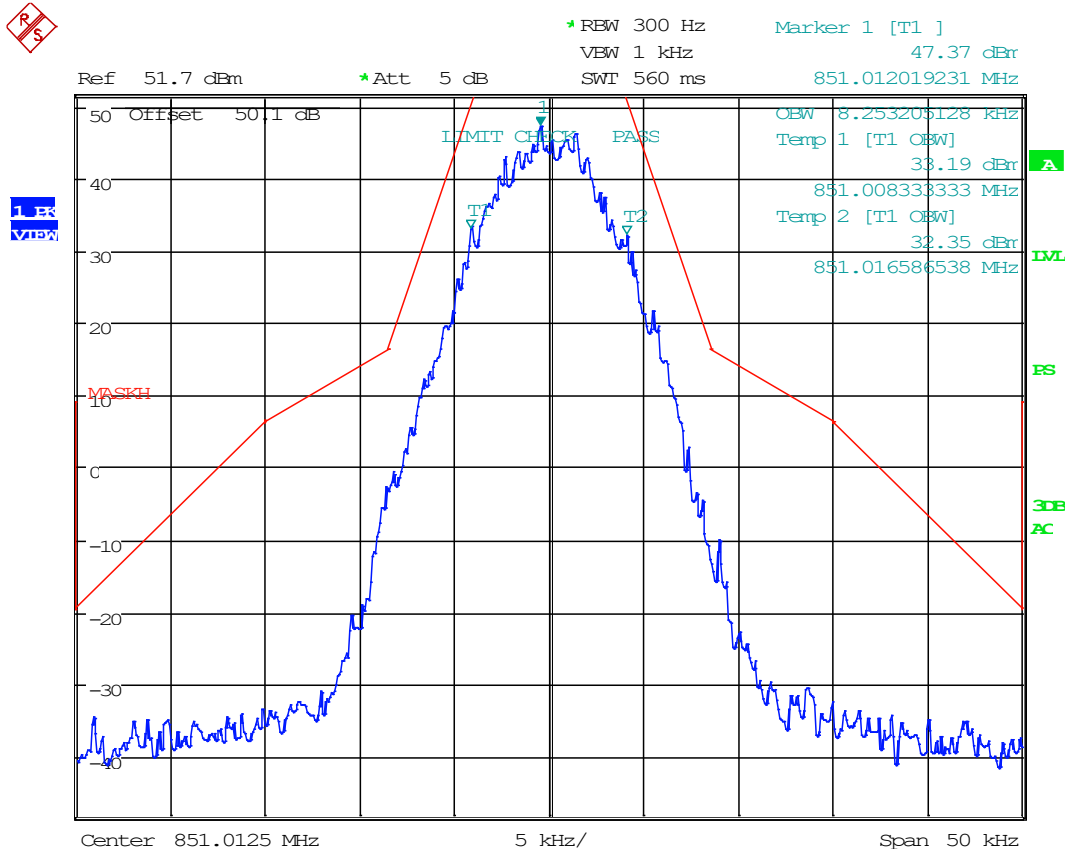

Date: 12.NOV.2020 13:33:54





### 8.4.23 Emission Mask, 16K0F3E, 868.0125 MHz

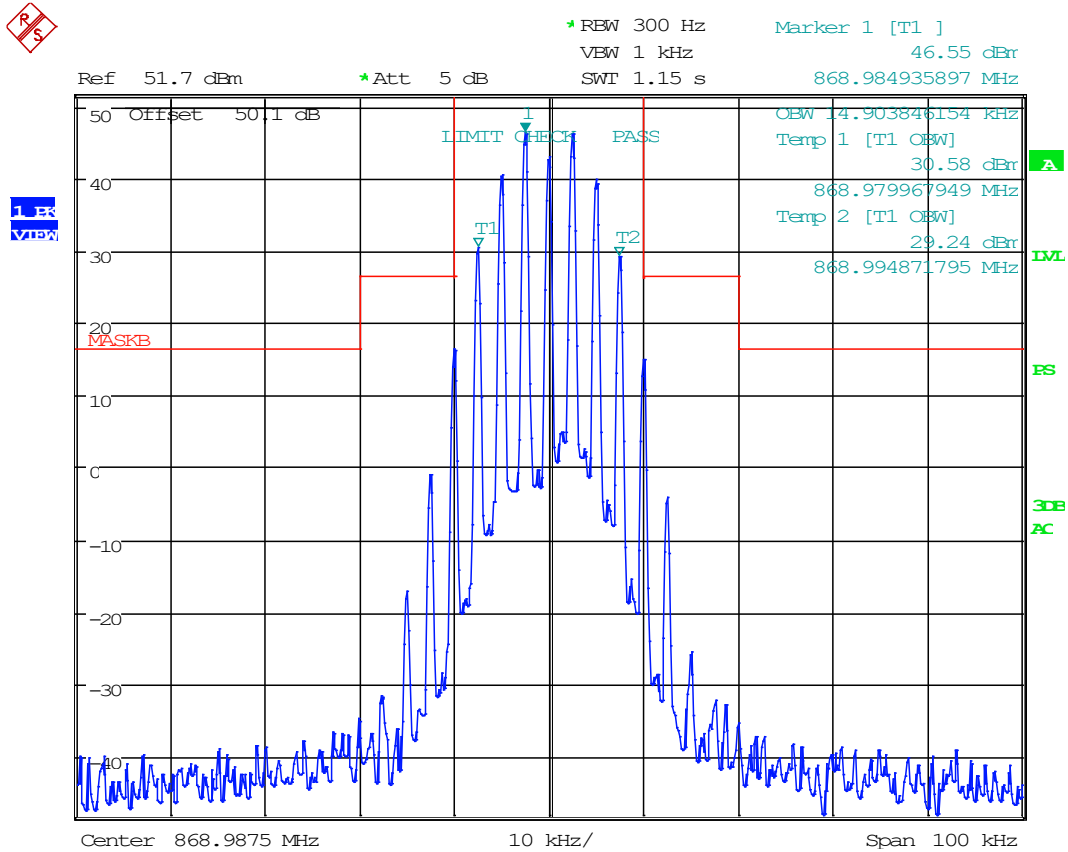

Date: 12.NOV.2020 13:27:56



### 8.4.25 Emission Mask, 7K80FXE/FXD/FXW, 868.0125 MHz

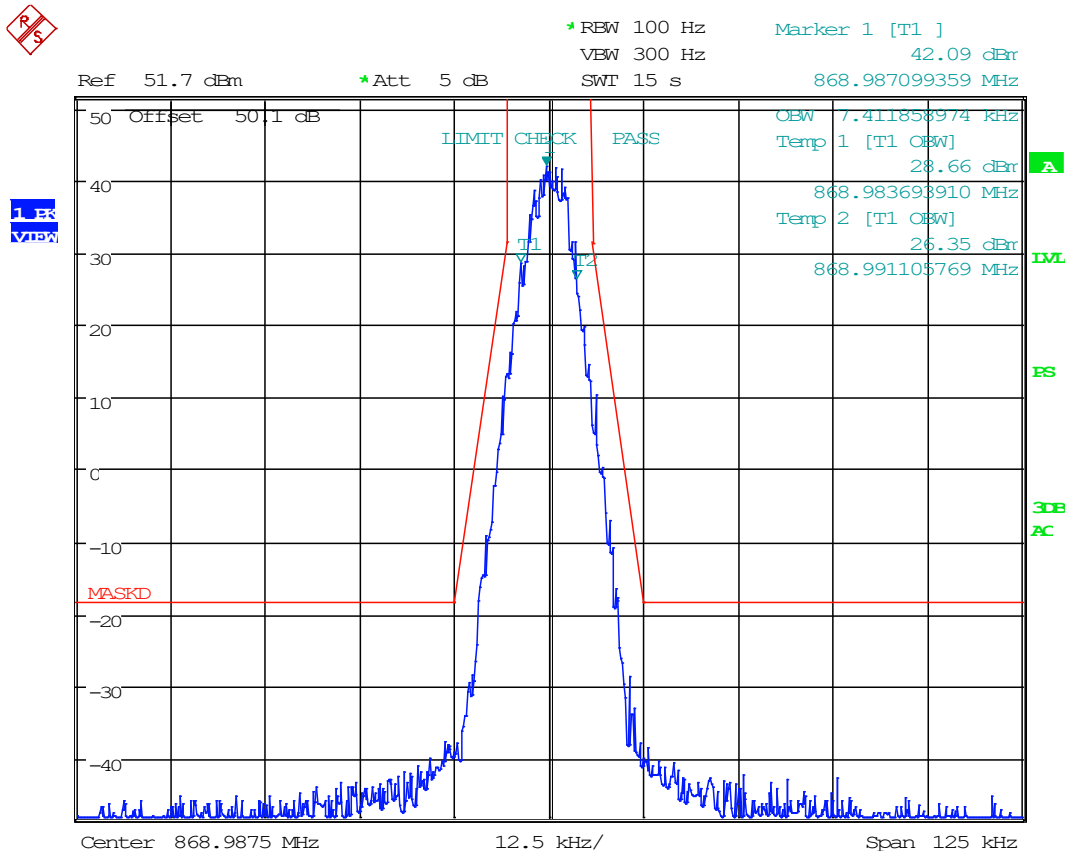

Date: 12.NOV.2020 13:43:06

## 8.5 Emission Limitations, Out-of-Band

Limits from FCC Parts 2.1051, and 90.210; and test procedure from ANSI C63.26-2015.

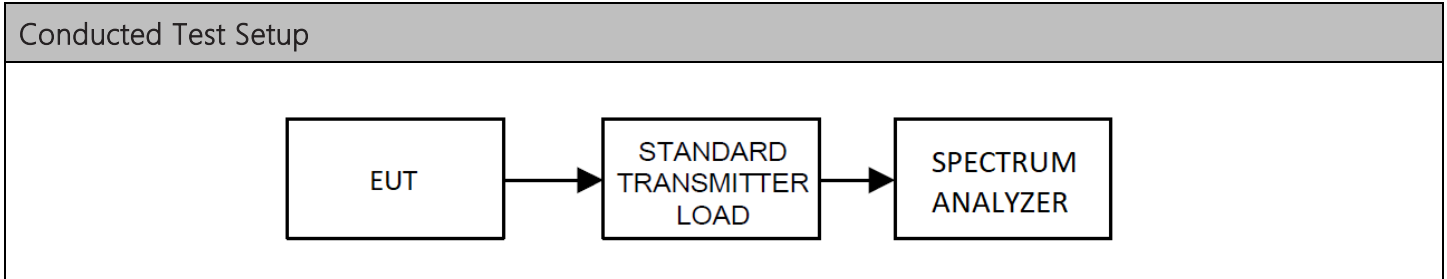

Conducted Emissions Spectrum Plots

8.5.1 Conducted Emissions, 30 MHz to 1 GHz, 763.0125 MHz

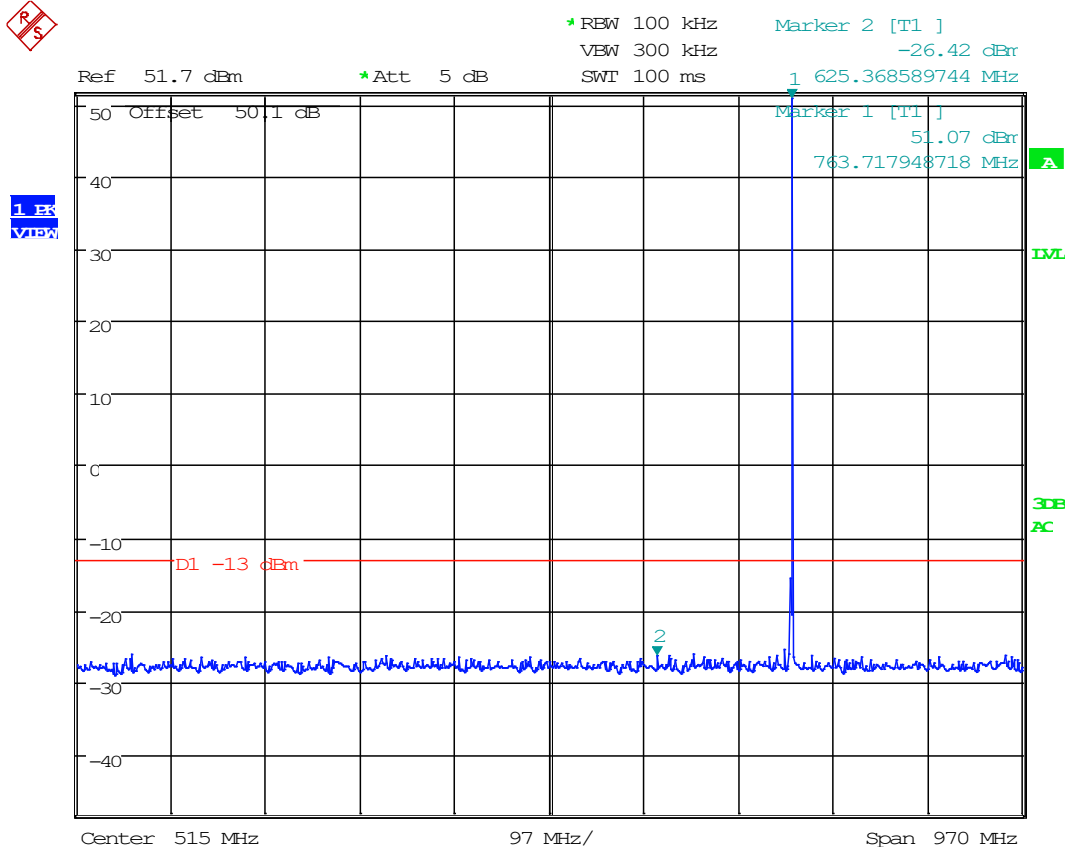

Date: 12.NOV.2020 18:07:04

### 8.5.2 Conducted Emissions, 1 GHz to 10<sup>th</sup> Harmonic, 763.0125 MHz

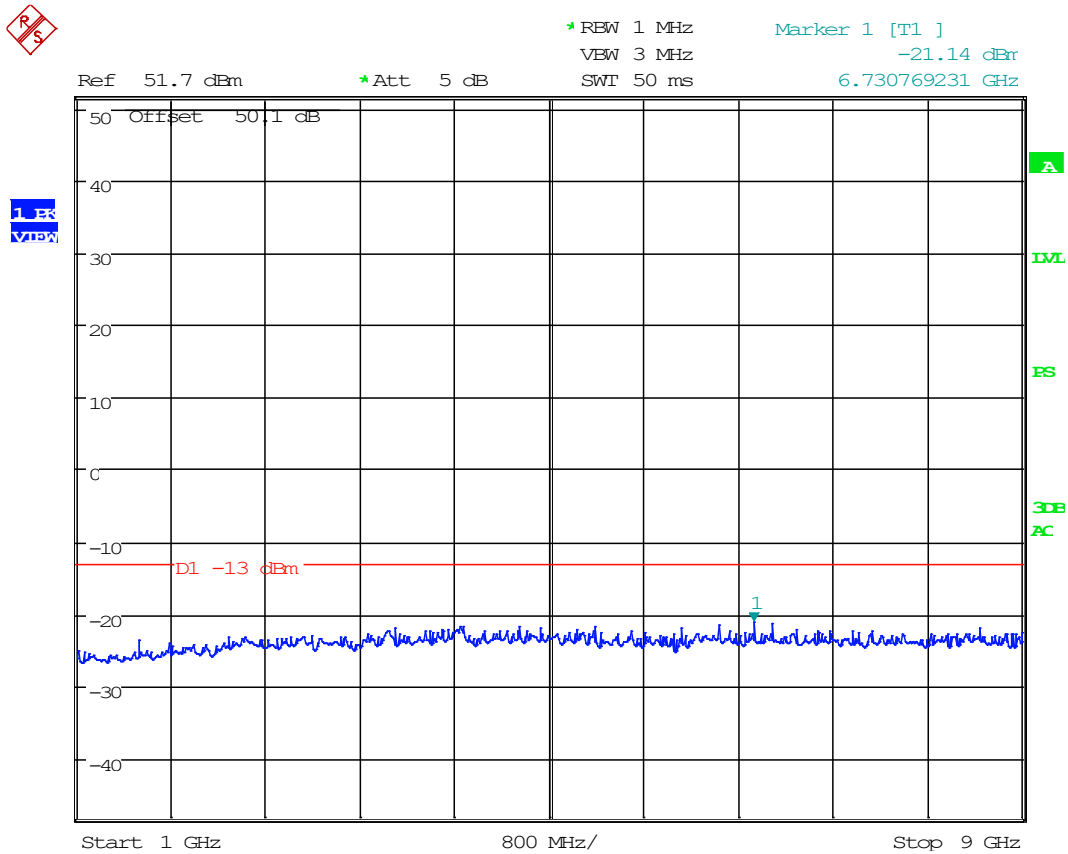

Date: 12.NOV.2020 18:08:31

### 8.5.3 Conducted Emissions, 30 MHz to 1 GHz, 774.9875 MHz

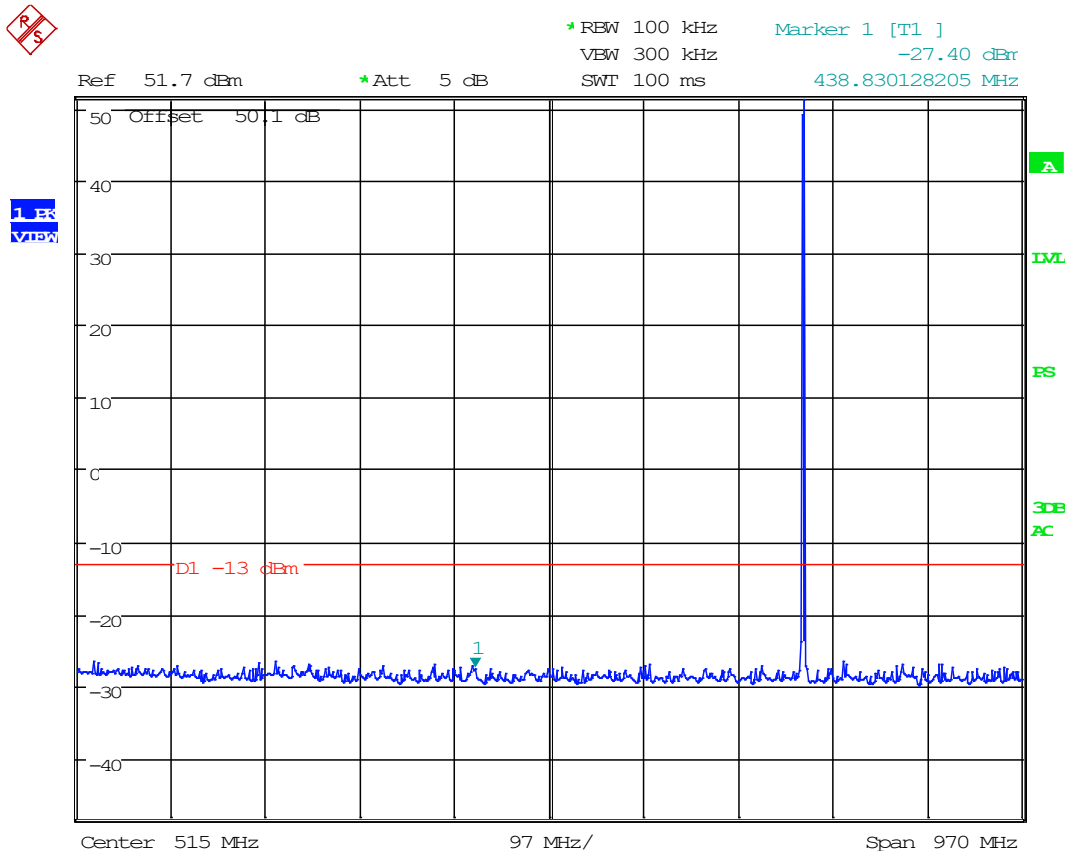

Date: 12.NOV.2020 18:10:55



### 8.5.4 Conducted Emissions, 1 GHz to 10<sup>th</sup> Harmonic, 774.9875 MHz

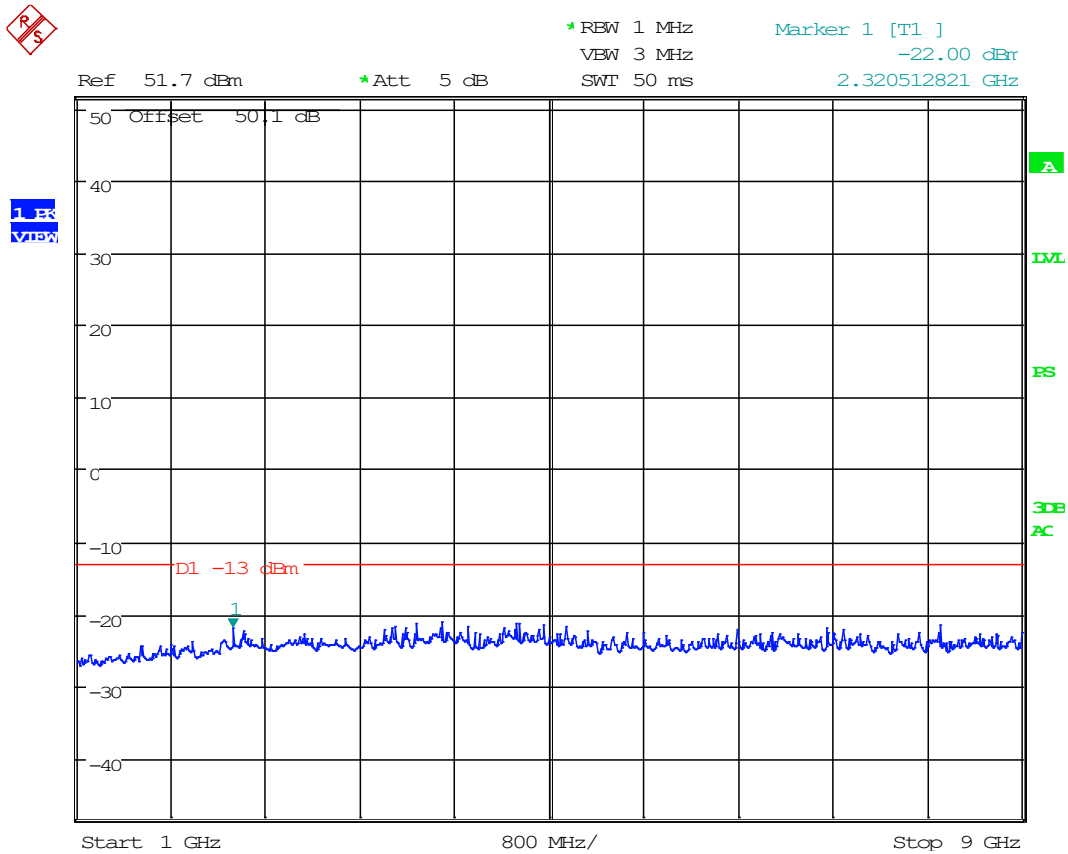

Date: 12.NOV.2020 18:11:11

### 8.5.5 Conducted Emissions, 30 MHz to 1 GHz, 804.9875 MHz

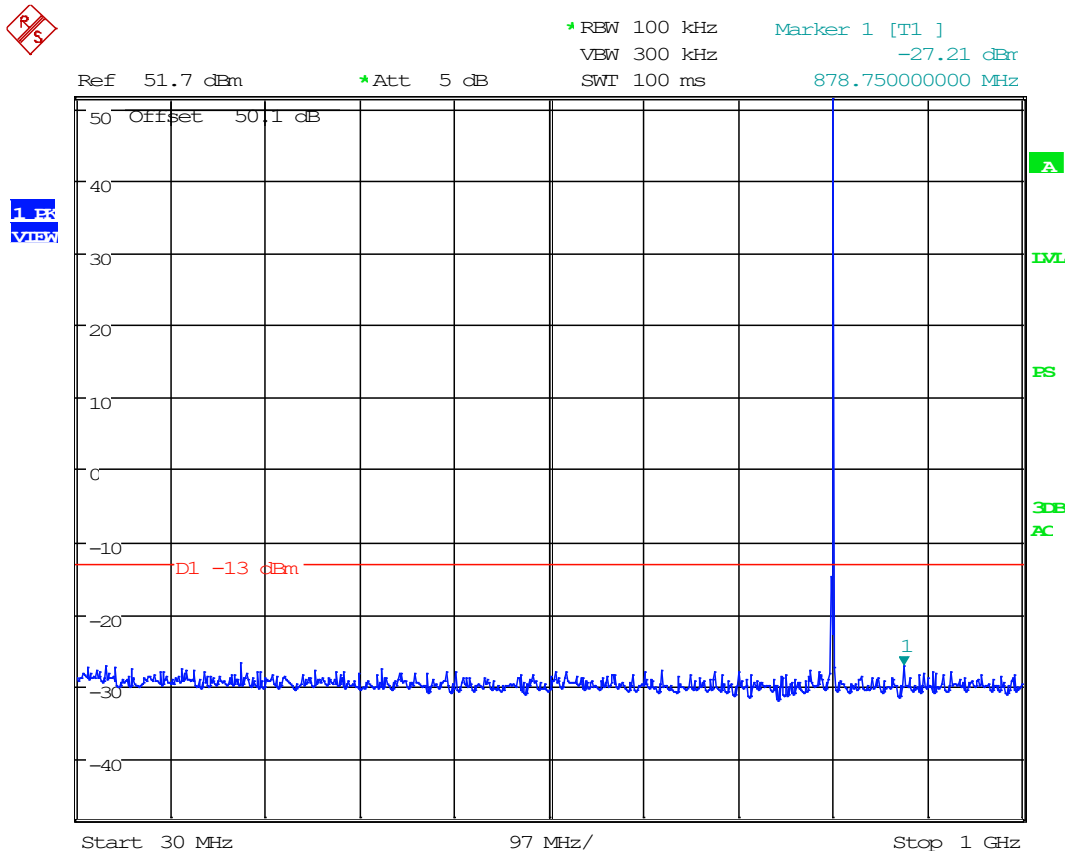

Date: 12.NOV.2020 18:14:08

### 8.5.6 Conducted Emissions, 1 GHz to 10<sup>th</sup> Harmonic, 804.0125 MHz

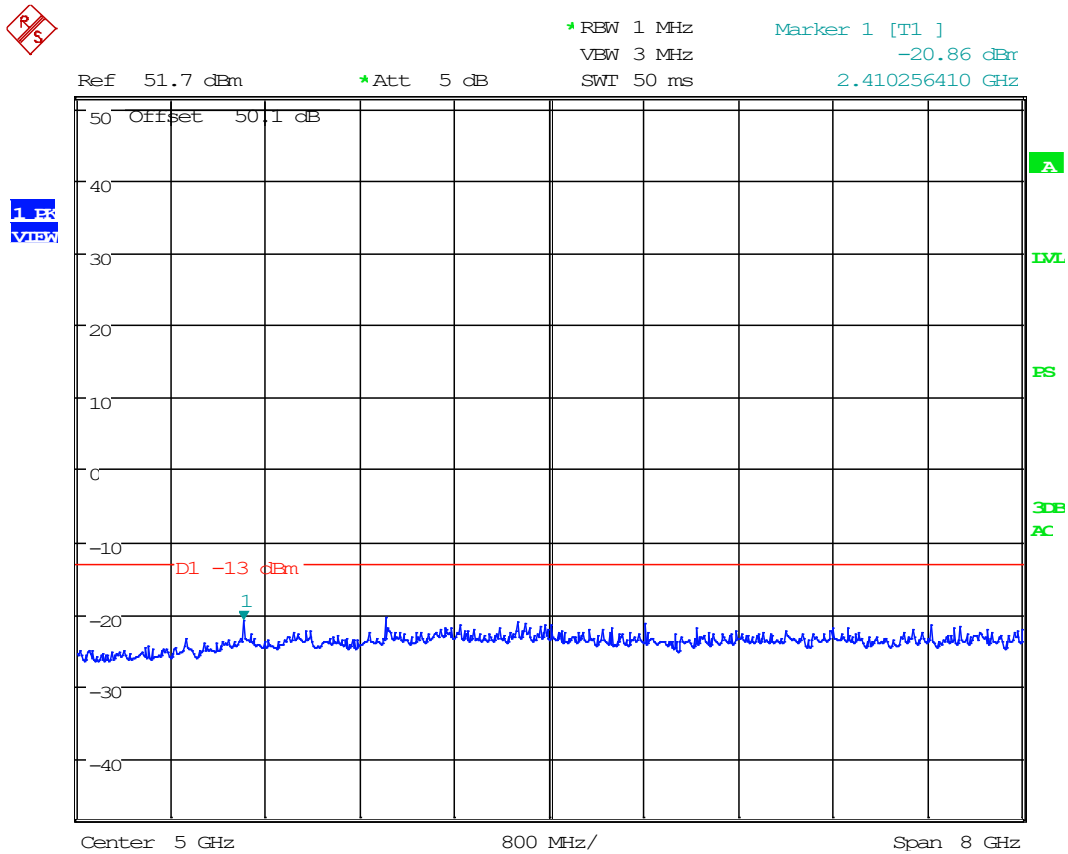

Date: 12.NOV.2020 18:13:25



### Conducted Emissions Mask, Spectrum Plots, 800 Band

#### 8.5.7 Conducted Emissions, 30 MHz to 1 GHz, 806.0125 MHz

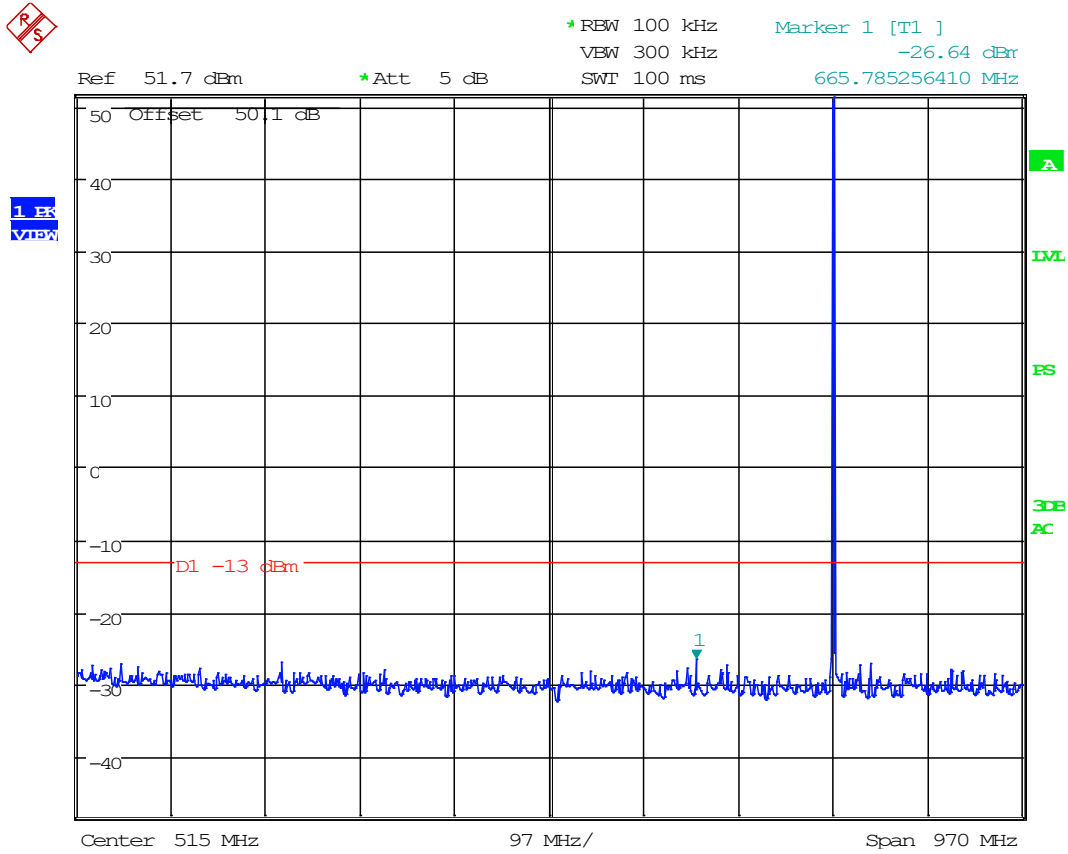

Date: 12.NOV.2020 18:17:06





### 8.5.10 Conducted Emissions, 1 GHz to 10<sup>th</sup> Harmonic, 823.9875 MHz

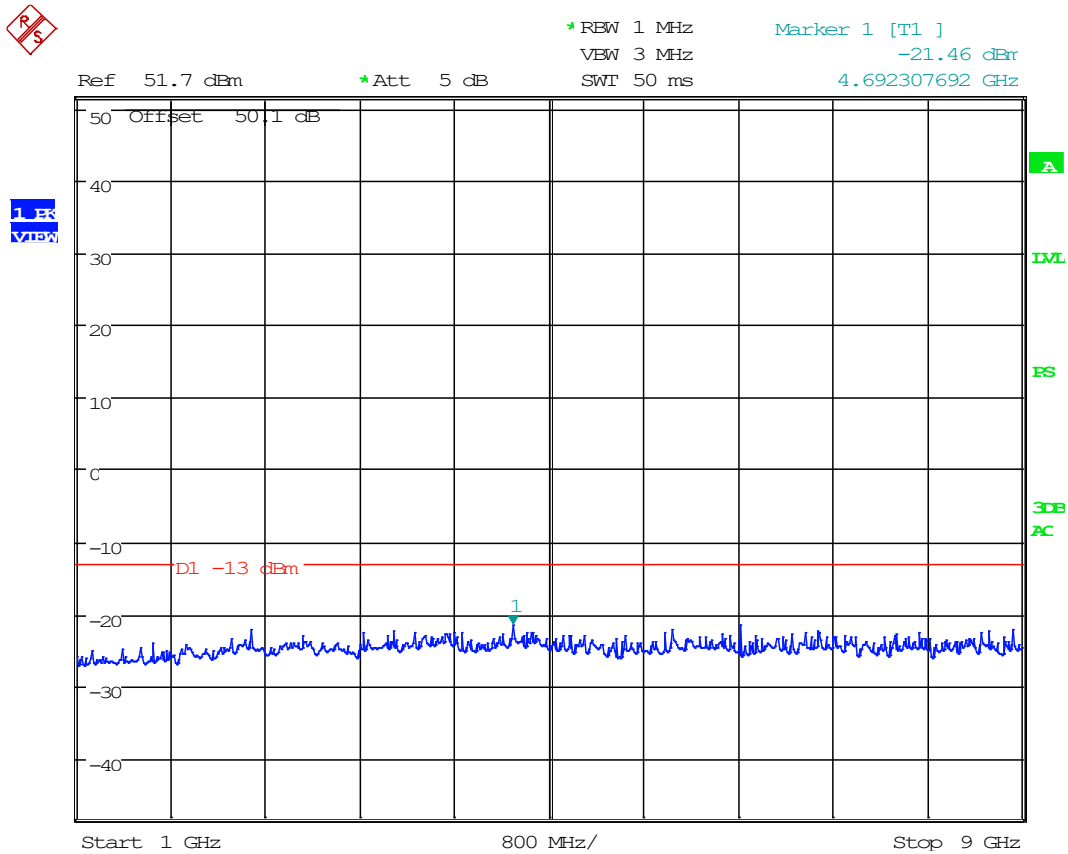

Date: 12.NOV.2020 18:17:58

### 8.5.11 Conducted Emissions, 30 MHz to 1 GHz, 851.0125 MHz

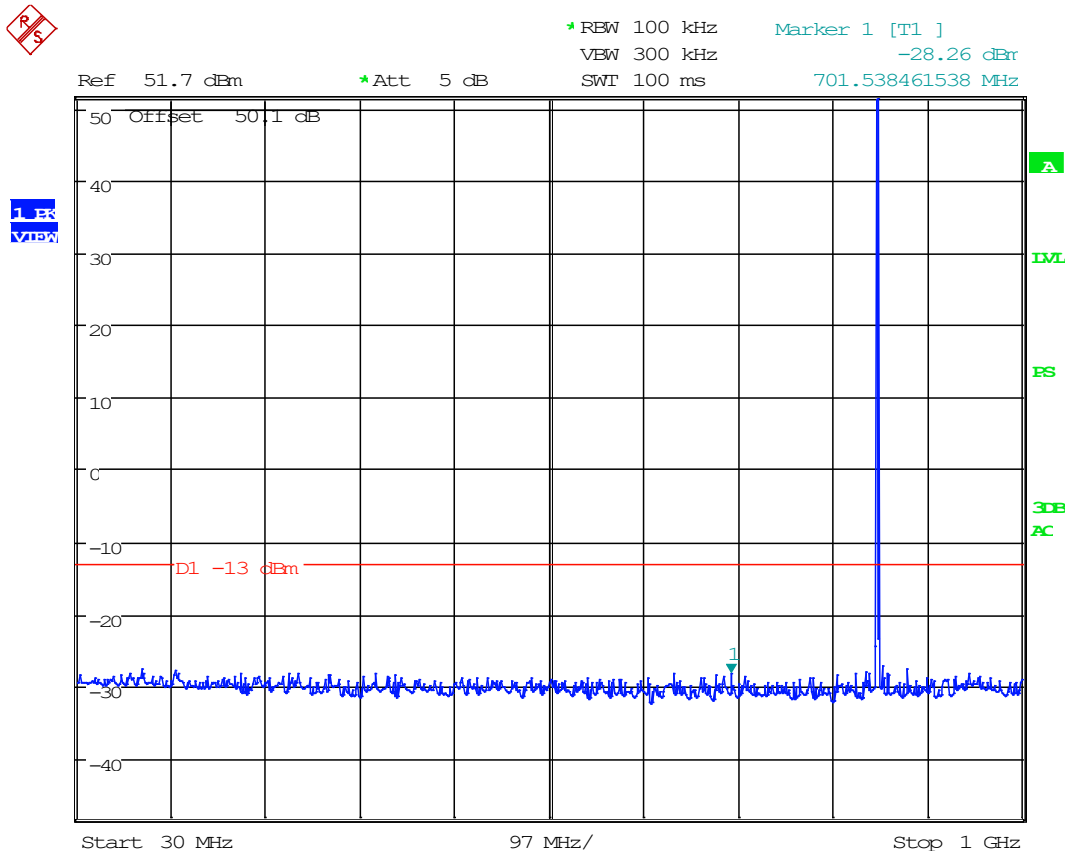

Date: 12.NOV.2020 18:19:06



### 8.5.12 Conducted Emissions, 1 GHz to 10<sup>th</sup> Harmonic, 851.0125 MHz

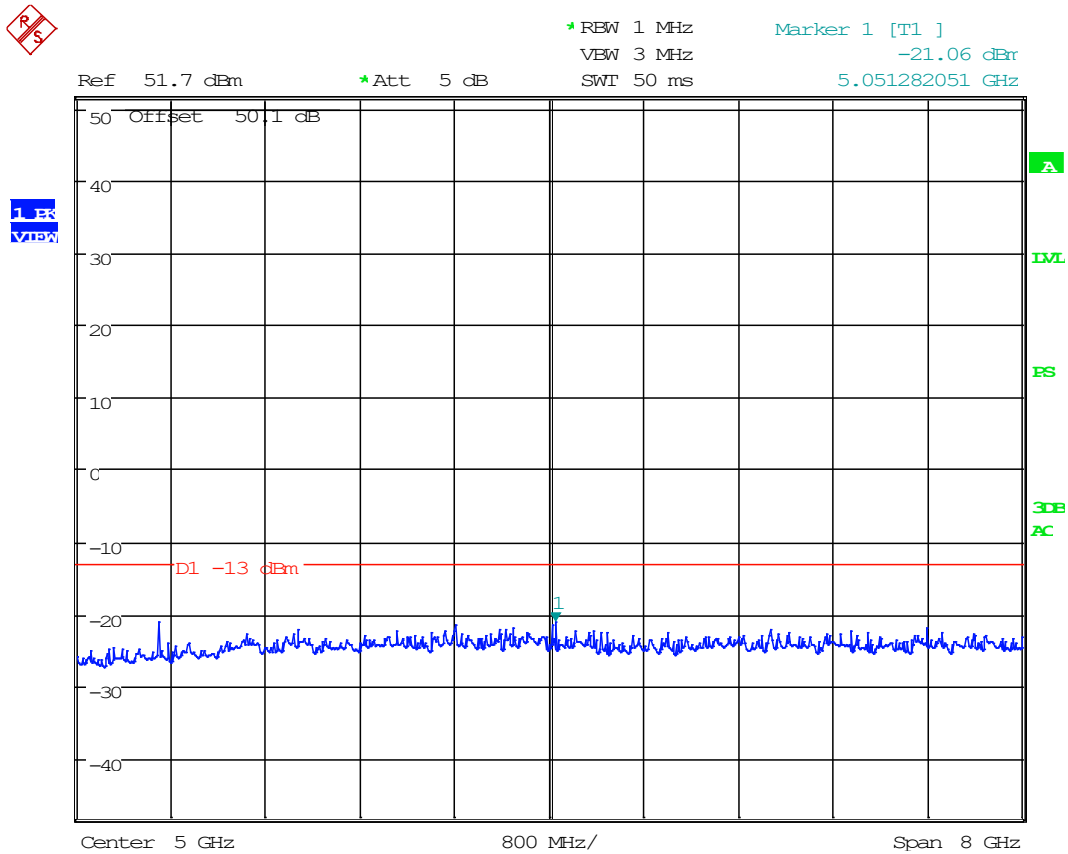

Date: 12.NOV.2020 18:18:42





## 8.6 Radiated Emissions

Limits from FCC Parts 2.1053, and 90.210; and test procedure from ANSI C63.26-2015.

### Radiated Test Setup, 30 – 1000 MHz

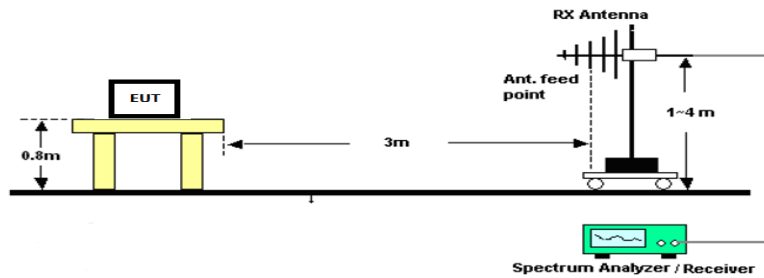

### Radiated Test Setup, Above 1000 MHz

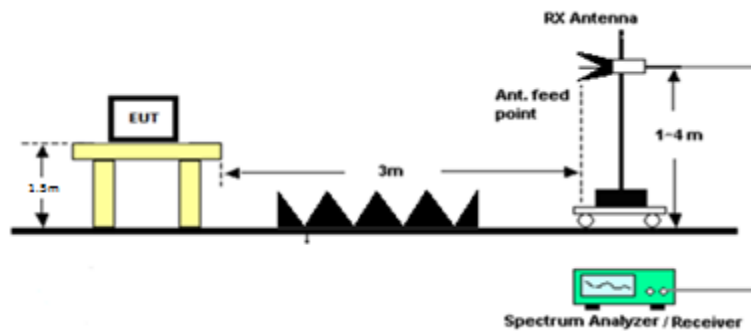



Radiated Emissions, Tabular Data, 700 MHz Band

8.6.1 Radiated Emissions, 763.0125 MHz

Tuned Frequency (MHz)	Emission Frequency (MHz)	Detector	Meter Reading (dBm)	Antenna Polarity	Coax Loss (dB)	Antenna Correction Factor (dB/m)	Distance (m)	Field Strength (dBµV/m)	ERP (dBm)	Spurious Limit (dBm)	Margin (dB)
763.01	220.48	PK	37.02	H	1.70	10.30	3.00	49.02	-48.36	-13.00	35.36
763.01	341.40	PK	20.86	H	2.12	13.70	3.00	36.68	-60.70	-13.00	47.70
763.01	474.56	PK	23.69	V	2.56	16.98	3.00	43.23	-54.15	-13.00	41.15
763.01	219.20	PK	33.95	V	1.69	10.32	3.00	45.96	-51.42	-13.00	38.42
763.01	1526.03	PK	30.32	H	4.53	27.76	3.00	62.61	-34.76	-13.00	21.76
763.01	1526.03	PK	26.59	V	4.53	27.76	3.00	58.88	-38.49	-13.00	25.49
763.01	2289.04	PK	26.92	H	5.48	31.46	3.00	63.85	-33.52	-13.00	20.52
763.01	2289.04	PK	27.56	V	5.48	31.46	3.00	64.49	-32.88	-13.00	19.88
763.01	3052.05	PK	41.26	H	6.41	32.64	3.00	80.30	-17.07	-13.00	4.07
763.01	3052.05	PK	35.77	V	6.41	32.64	3.00	74.81	-22.56	-13.00	9.56
763.01	3815.06	PK	16.31	H	6.38	33.16	3.00	55.85	-41.52	-13.00	28.52
763.01	3815.06	PK	21.80	V	6.38	33.16	3.00	61.34	-36.03	-13.00	23.03
763.01	4578.08	PK	16.31	H	7.53	34.03	3.00	57.87	-39.51	-13.00	26.51
763.01	4578.08	PK	23.26	V	7.53	34.03	3.00	64.82	-32.56	-13.00	19.56
763.01	5341.09	PK	12.60	H	8.04	34.28	3.00	54.93	-42.45	-13.00	29.45
763.01	5341.09	PK	12.18	V	8.04	34.28	3.00	54.51	-42.87	-13.00	29.87
763.01	6104.10	PK	12.64	H	8.62	35.24	3.00	56.50	-40.88	-13.00	27.88
763.01	6104.10	PK	13.33	V	8.62	35.24	3.00	57.19	-40.19	-13.00	27.19
763.01	6867.11	PK	12.58	H	9.22	35.87	3.00	57.67	-39.70	-13.00	26.70
763.01	6867.11	PK	11.88	V	9.22	35.87	3.00	56.97	-40.40	-13.00	27.40
763.01	7630.13	PK	10.46	H	10.01	35.90	3.00	56.37	-41.01	-13.00	28.01
763.01	7630.13	PK	10.38	V	10.01	35.90	3.00	56.29	-41.09	-13.00	28.09

8.6.2 Radiated Emissions, 774.9875 MHz

Tuned Frequency (MHz)	Emission Frequency (MHz)	Detector	Meter Reading (dBm)	Antenna Polarity	Coax Loss (dB)	Antenna Correction Factor (dB/m)	Distance (m)	Field Strength (dBµV/m)	ERP (dBm)	Spurious Limit (dBm)	Margin (dB)
774.99	343.36	PK	23.27	H	2.12	13.70	3.00	39.09	-58.29	-13.00	45.29
774.99	219.84	PK	37.97	H	1.70	10.30	3.00	49.97	-47.41	-13.00	34.41
774.99	474.56	PK	23.81	V	2.56	16.98	3.00	43.35	-54.03	-13.00	41.03
774.99	223.04	PK	34.49	V	1.71	10.30	3.00	46.50	-50.88	-13.00	37.88
774.99	1549.98	PK	34.73	H	4.57	27.76	3.00	67.05	-30.32	-13.00	17.32
774.99	1549.98	PK	33.45	V	4.57	27.76	3.00	65.77	-31.60	-13.00	18.60
774.99	2324.96	PK	27.61	H	5.53	31.72	3.00	64.86	-32.51	-13.00	19.51
774.99	2324.96	PK	26.76	V	5.53	31.72	3.00	64.01	-33.36	-13.00	20.36
774.99	3099.95	PK	38.53	H	6.45	32.76	3.00	77.74	-19.63	-13.00	6.63
774.99	3099.95	PK	37.49	V	6.45	32.76	3.00	76.70	-20.67	-13.00	7.67
774.99	3874.94	PK	23.61	H	6.73	33.22	3.00	63.56	-33.82	-13.00	20.82
774.99	3874.94	PK	22.40	V	6.73	33.22	3.00	62.35	-35.03	-13.00	22.03
774.99	4649.93	PK	17.19	H	7.45	33.90	3.00	58.54	-38.84	-13.00	25.84
774.99	4649.93	PK	17.64	V	7.45	33.90	3.00	58.99	-38.39	-13.00	25.39
774.99	5424.91	PK	9.78	H	8.15	34.41	3.00	52.34	-45.04	-13.00	32.04
774.99	5424.91	PK	9.93	V	8.15	34.41	3.00	52.49	-44.89	-13.00	31.89
774.99	6199.90	PK	9.09	H	8.64	35.31	3.00	53.05	-44.33	-13.00	31.33
774.99	6199.90	PK	14.84	V	8.64	35.31	3.00	58.80	-38.58	-13.00	25.58
774.99	6974.89	PK	12.26	H	9.24	36.16	3.00	57.65	-39.72	-13.00	26.72
774.99	6974.89	PK	14.68	V	9.24	36.16	3.00	60.07	-37.30	-13.00	24.30
774.99	7749.88	PK	8.77	H	10.12	35.87	3.00	54.76	-42.61	-13.00	29.61
774.99	7749.88	PK	9.65	V	10.12	35.87	3.00	55.64	-41.73	-13.00	28.73



Timco Engineering, Inc., an IIA Company  
 849 NW State Road 45, Newberry, Florida 32669  
 (352) 472-5500 / [testing@timcoengr.com](mailto:testing@timcoengr.com)

### 8.6.3 Radiated Emissions, 804.9875 MHz

Tuned Frequency (MHz)	Emission Frequency (MHz)	Detector	Meter Reading (dBm)	Antenna Polarity	Coax Loss (dB)	Antenna Correction Factor (dB/m)	Distance (m)	Field Strength (dBμV/m)	ERP (dBm)	Spurious Limit (dBm)	Margin (dB)
804.99	223.04	PK	31.30	V	1.71	10.30	3.00	43.31	-54.07	-13.00	41.07
804.99	473.30	PK	20.45	V	2.55	16.93	3.00	39.93	-57.45	-13.00	44.45
804.99	220.50	PK	31.12	H	1.70	10.30	3.00	43.12	-54.26	-13.00	41.26
804.99	338.20	PK	20.06	H	2.11	13.70	3.00	35.87	-61.50	-13.00	48.50
804.99	1609.98	PK	32.69	H	4.67	28.18	3.00	65.54	-31.84	-13.00	18.84
804.99	1609.98	PK	34.58	V	4.67	28.18	3.00	67.43	-29.95	-13.00	16.95
804.99	2414.96	PK	30.05	H	5.61	31.87	3.00	67.53	-29.85	-13.00	16.85
804.99	2414.96	PK	26.23	V	5.61	31.87	3.00	63.71	-33.67	-13.00	20.67
804.99	3219.95	PK	40.02	H	6.63	32.68	3.00	79.33	-18.05	-13.00	5.05
804.99	3219.95	PK	41.75	V	6.63	32.68	3.00	81.06	-16.32	-13.00	3.32
804.99	4024.94	PK	19.30	H	7.23	33.39	3.00	59.91	-37.46	-13.00	24.46
804.99	4024.94	PK	17.71	V	7.23	33.39	3.00	58.32	-39.05	-13.00	26.05
804.99	4829.93	PK	10.71	H	7.17	33.94	3.00	51.82	-45.56	-13.00	32.56
804.99	4829.93	PK	14.03	V	7.17	33.94	3.00	55.14	-42.24	-13.00	29.24
804.99	5634.91	PK	10.77	H	8.20	34.51	3.00	53.48	-43.89	-13.00	30.89
804.99	5634.91	PK	9.63	V	8.20	34.51	3.00	52.34	-45.03	-13.00	32.03
804.99	6439.90	PK	17.48	H	8.96	35.51	3.00	61.94	-35.43	-13.00	22.43
804.99	6439.90	PK	14.69	V	8.96	35.51	3.00	59.15	-38.22	-13.00	25.22
804.99	7244.89	PK	11.82	H	9.51	36.32	3.00	57.65	-39.72	-13.00	26.72
804.99	7244.89	PK	10.04	V	9.51	36.32	3.00	55.87	-41.50	-13.00	28.50
804.99	8049.88	PK	12.79	H	9.89	35.77	3.00	58.45	-38.92	-13.00	25.92
804.99	8049.88	PK	11.72	V	9.89	35.77	3.00	57.38	-39.99	-13.00	26.99



Radiated Emissions, Tabular Data, 800 MHz Band

8.6.4 Radiated Emissions, 806.0125 MHz

Tuned Frequency (MHz)	Emission Frequency (MHz)	Detector	Meter Reading (dBm)	Antenna Polarity	Coax Loss (dB)	Antenna Correction Factor (dB/m)	Distance (m)	Field Strength (dBµV/m)	ERP (dBm)	Spurious Limit (dBm)	Margin (dB)
806.01	219.80	PK	35.43	H	1.70	10.30	3.00	47.43	-49.94	-13.00	36.94
806.01	344.60	PK	20.47	H	2.12	13.70	3.00	36.29	-61.09	-13.00	48.09
806.01	219.80	PK	32.44	V	1.70	10.30	3.00	44.44	-52.93	-13.00	39.93
806.01	473.30	PK	18.00	V	2.55	16.93	3.00	37.48	-59.90	-13.00	46.90
806.01	1612.03	PK	33.42	H	4.68	28.20	3.00	66.30	-31.08	-13.00	18.08
806.01	1612.03	PK	31.66	V	4.68	28.20	3.00	64.54	-32.84	-13.00	19.84
806.01	2418.04	PK	27.64	H	5.61	31.86	3.00	65.12	-32.26	-13.00	19.26
806.01	2418.04	PK	29.47	V	5.61	31.86	3.00	66.95	-30.43	-13.00	17.43
806.01	3224.05	PK	41.48	H	6.64	32.68	3.00	80.79	-16.58	-13.00	3.58
806.01	3224.05	PK	40.18	V	6.64	32.68	3.00	79.49	-17.88	-13.00	4.88
806.01	4030.06	PK	19.00	H	7.22	33.39	3.00	59.60	-37.77	-13.00	24.77
806.01	4030.06	PK	19.66	V	7.22	33.39	3.00	60.26	-37.11	-13.00	24.11
806.01	4836.08	PK	13.52	H	7.18	33.94	3.00	54.65	-42.73	-13.00	29.73
806.01	4836.08	PK	11.14	V	7.18	33.94	3.00	52.27	-45.11	-13.00	32.11
806.01	5642.09	PK	10.94	H	8.18	34.52	3.00	53.64	-43.73	-13.00	30.73
806.01	5642.09	PK	11.24	V	8.18	34.52	3.00	53.94	-43.43	-13.00	30.43
806.01	6448.10	PK	15.01	H	8.97	35.52	3.00	59.50	-37.87	-13.00	24.87
806.01	6448.10	PK	19.18	V	8.97	35.52	3.00	63.67	-33.70	-13.00	20.70
806.01	7254.11	PK	9.26	H	9.51	36.31	3.00	55.09	-42.29	-13.00	29.29
806.01	7254.11	PK	10.16	V	9.51	36.31	3.00	55.99	-41.39	-13.00	28.39
806.01	8060.13	PK	12.89	H	9.88	35.78	3.00	58.54	-38.83	-13.00	25.83
806.01	8060.13	PK	9.99	V	9.88	35.78	3.00	55.64	-41.73	-13.00	28.73

8.6.5 Radiated Emissions, 823.9875 MHz

Tuned Frequency (MHz)	Emission Frequency (MHz)	Detector	Meter Reading (dBm)	Antenna Polarity	Coax Loss (dB)	Antenna Correction Factor (dB/m)	Distance (m)	Field Strength (dBµV/m)	ERP (dBm)	Spurious Limit (dBm)	Margin (dB)
823.99	220.50	PK	34.38	V	1.70	10.30	3.00	46.38	-51.00	-13.00	38.00
823.99	474.50	PK	18.40	V	2.56	16.98	3.00	37.94	-59.44	-13.00	46.44
823.99	222.40	PK	30.00	H	1.71	10.30	3.00	42.01	-55.37	-13.00	42.37
823.99	343.36	PK	20.24	H	2.12	13.70	3.00	36.06	-61.32	-13.00	48.32
823.99	1647.98	PK	29.46	H	4.72	28.58	3.00	62.77	-34.61	-13.00	21.61
823.99	1647.98	PK	35.02	V	4.72	28.58	3.00	68.33	-29.05	-13.00	16.05
823.99	2471.96	PK	28.90	H	5.62	32.03	3.00	66.55	-30.83	-13.00	17.83
823.99	2471.96	PK	26.31	V	5.62	32.03	3.00	63.96	-33.42	-13.00	20.42
823.99	3295.95	PK	33.72	H	6.70	32.63	3.00	73.05	-24.33	-13.00	11.33
823.99	3295.95	PK	38.78	V	6.70	32.63	3.00	78.11	-19.27	-13.00	6.27
823.99	4119.94	PK	18.03	H	7.09	33.41	3.00	58.53	-38.85	-13.00	25.85
823.99	4119.94	PK	19.91	V	7.09	33.41	3.00	60.41	-36.97	-13.00	23.97
823.99	4943.93	PK	11.07	H	7.77	33.94	3.00	52.78	-44.60	-13.00	31.60
823.99	4943.93	PK	15.21	V	7.77	33.94	3.00	56.92	-40.46	-13.00	27.46
823.99	5767.91	PK	11.55	H	8.23	34.70	3.00	54.48	-42.90	-13.00	29.90
823.99	5767.91	PK	9.80	V	8.23	34.70	3.00	52.73	-44.65	-13.00	31.65
823.99	6591.90	PK	13.41	H	9.20	35.65	3.00	58.26	-39.12	-13.00	26.12
823.99	6591.90	PK	17.05	V	9.20	35.65	3.00	61.90	-35.48	-13.00	22.48
823.99	7415.89	PK	11.61	H	9.52	36.04	3.00	57.17	-40.21	-13.00	27.21
823.99	7415.89	PK	10.46	V	9.52	36.04	3.00	56.02	-41.36	-13.00	28.36
823.99	8239.88	PK	11.09	H	10.02	35.80	3.00	56.90	-40.47	-13.00	27.47
823.99	8239.88	PK	10.28	V	10.02	35.80	3.00	56.09	-41.28	-13.00	28.28



### 8.6.6 Radiated Emissions, 851.0125 MHz

Tuned Frequency (MHz)	Emission Frequency (MHz)	Detector	Meter Reading (dBm)	Antenna Polarity	Coax Loss (dB)	Antenna Correction Factor (dB/m)	Distance (m)	Field Strength (dBµV/m)	ERP (dBm)	Spurious Limit (dBm)	Margin (dB)
851.01	220.50	PK	33.18	V	1.70	10.30	3.00	45.18	-52.20	-13.00	39.20
851.01	462.40	PK	18.40	V	2.50	15.84	3.00	36.74	-60.64	-13.00	47.64
851.01	220.50	PK	30.23	H	1.70	10.30	3.00	42.23	-55.15	-13.00	42.15
851.01	342.70	PK	21.35	H	2.12	13.70	3.00	37.17	-60.21	-13.00	47.21
851.01	1702.03	PK	19.15	H	4.78	29.10	3.00	53.03	-44.35	-13.00	31.35
851.01	1702.03	PK	23.29	V	4.78	29.10	3.00	57.17	-40.21	-13.00	27.21
851.01	2553.04	PK	32.25	H	5.70	32.60	3.00	70.54	-26.83	-13.00	13.83
851.01	2553.04	PK	35.76	V	5.70	32.60	3.00	74.05	-23.32	-13.00	10.32
851.01	3404.05	PK	30.07	H	6.80	32.65	3.00	69.51	-27.86	-13.00	14.86
851.01	3404.05	PK	35.33	V	6.80	32.65	3.00	74.77	-22.60	-13.00	9.60
851.01	4255.06	PK	15.92	H	7.22	33.35	3.00	56.49	-40.89	-13.00	27.89
851.01	4255.06	PK	16.39	V	7.22	33.35	3.00	56.96	-40.42	-13.00	27.42
851.01	5106.08	PK	13.08	H	7.90	34.09	3.00	55.08	-42.30	-13.00	29.30
851.01	5106.08	PK	17.23	V	7.90	34.09	3.00	59.23	-38.15	-13.00	25.15
851.01	5957.09	PK	19.01	H	8.54	35.05	3.00	62.61	-34.77	-13.00	21.77
851.01	5957.09	PK	17.60	V	8.54	35.05	3.00	61.20	-36.18	-13.00	23.18
851.01	6808.10	PK	16.18	H	9.23	35.86	3.00	61.27	-36.11	-13.00	23.11
851.01	6808.10	PK	15.06	V	9.23	35.86	3.00	60.15	-37.23	-13.00	24.23
851.01	7659.11	PK	10.41	H	10.06	35.93	3.00	56.40	-40.98	-13.00	27.98
851.01	7659.11	PK	10.74	V	10.06	35.93	3.00	56.73	-40.65	-13.00	27.65
851.01	8510.13	PK	10.22	H	10.28	35.94	3.00	56.44	-40.94	-13.00	27.94
851.01	8510.13	PK	10.49	V	10.28	35.94	3.00	56.71	-40.67	-13.00	27.67

### 8.6.7 Radiated Emissions, 868.9875 MHz

Tuned Frequency (MHz)	Emission Frequency (MHz)	Detector	Meter Reading (dBm)	Antenna Polarity	Coax Loss (dB)	Antenna Correction Factor (dB/m)	Distance (m)	Field Strength (dBµV/m)	ERP (dBm)	Spurious Limit (dBm)	Margin (dB)
868.99	222.40	PK	33.22	V	1.71	10.30	3.00	45.23	-52.15	-13.00	39.15
868.99	474.50	PK	18.39	V	2.56	16.98	3.00	37.93	-59.45	-13.00	46.45
868.99	221.46	PK	30.57	H	1.71	10.30	3.00	42.58	-54.80	-13.00	41.80
868.99	344.60	PK	23.19	H	2.12	13.70	3.00	39.01	-58.37	-13.00	45.37
868.99	1737.98	PK	18.58	H	4.83	29.57	3.00	52.98	-44.40	-13.00	31.40
868.99	1737.98	PK	17.14	V	4.83	29.57	3.00	51.54	-45.84	-13.00	32.84
868.99	2606.96	PK	34.55	H	5.81	32.41	3.00	72.76	-24.61	-13.00	11.61
868.99	2606.96	PK	38.04	V	5.81	32.41	3.00	76.25	-21.12	-13.00	8.12
868.99	3475.95	PK	27.58	H	6.90	32.65	3.00	67.13	-30.25	-13.00	17.25
868.99	3475.95	PK	31.14	V	6.90	32.65	3.00	70.69	-26.69	-13.00	13.69
868.99	4344.94	PK	17.79	H	7.43	33.56	3.00	58.78	-38.60	-13.00	25.60
868.99	4344.94	PK	18.39	V	7.43	33.56	3.00	59.38	-38.00	-13.00	25.00
868.99	5213.93	PK	10.92	H	7.83	34.21	3.00	52.96	-44.41	-13.00	31.41
868.99	5213.93	PK	15.98	V	7.83	34.21	3.00	58.02	-39.35	-13.00	26.35
868.99	6082.91	PK	17.45	H	8.63	35.21	3.00	61.30	-36.08	-13.00	23.08
868.99	6082.91	PK	16.14	V	8.63	35.21	3.00	59.99	-37.39	-13.00	24.39
868.99	6951.90	PK	17.67	H	9.22	36.12	3.00	63.01	-34.37	-13.00	21.37
868.99	6951.90	PK	15.83	V	9.22	36.12	3.00	61.17	-36.21	-13.00	23.21
868.99	7820.89	PK	9.69	H	10.13	35.86	3.00	55.68	-41.70	-13.00	28.70
868.99	7820.89	PK	7.72	V	10.13	35.86	3.00	53.71	-43.67	-13.00	30.67
868.99	8689.88	PK	16.39	H	10.56	35.98	3.00	62.92	-34.45	-13.00	21.45
868.99	8689.88	PK	15.07	V	10.56	35.98	3.00	61.60	-35.77	-13.00	22.77



## 8.7 Modulation Characteristics

Limits from FCC Parts 2.1047; and test procedure from ANSI C63.26-2015

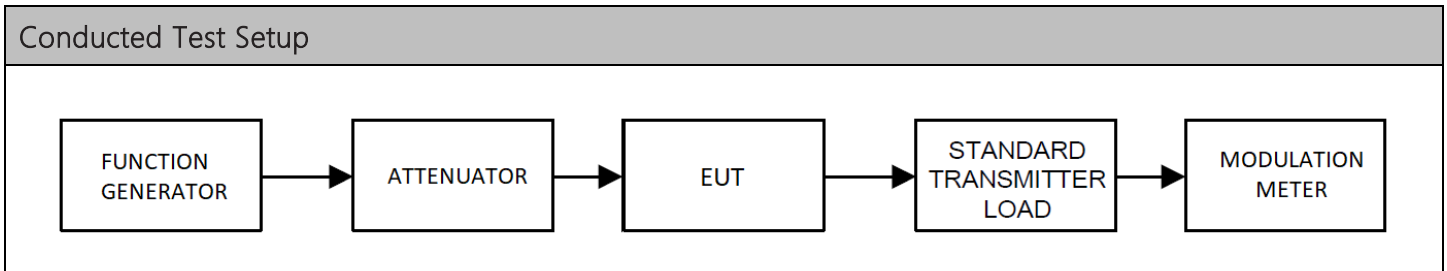



### 8.7.1 Audio Frequency Response, Narrowband FM

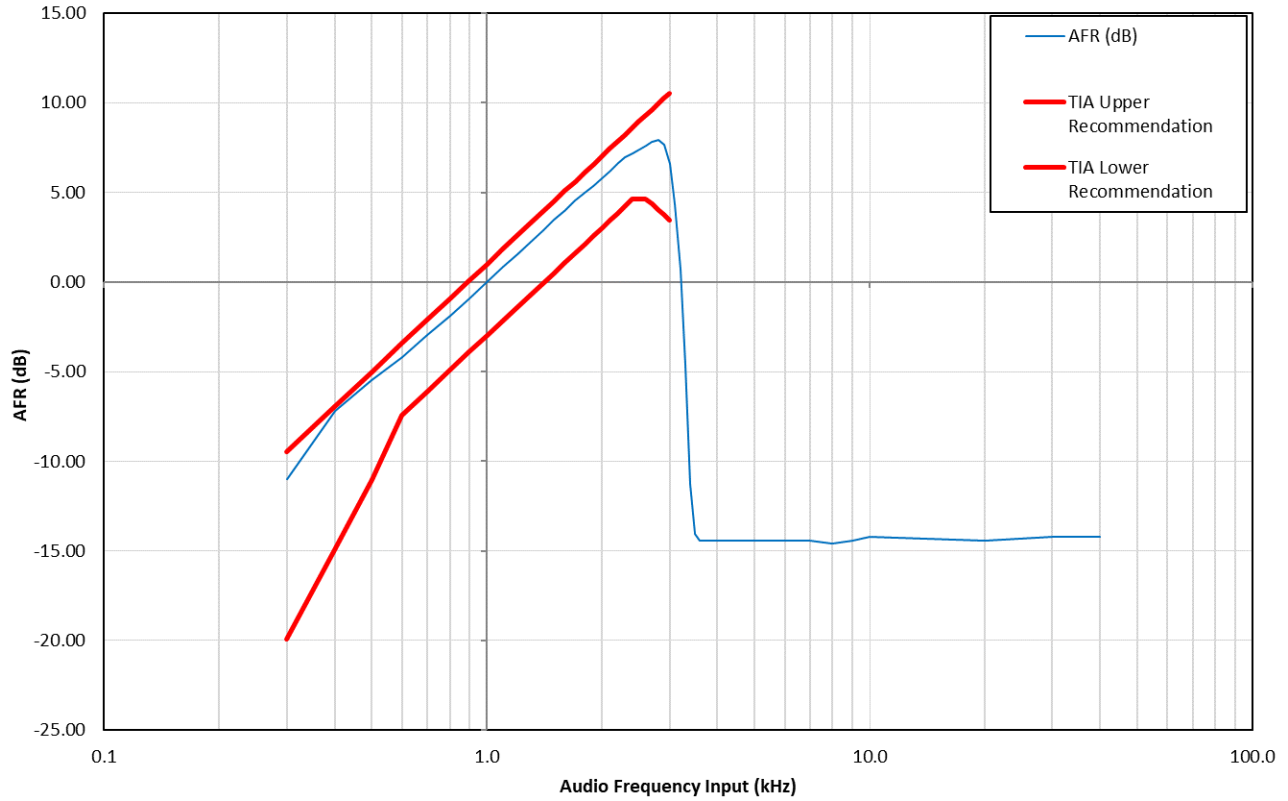

### 8.7.1 Audio Frequency Response, Wideband FM

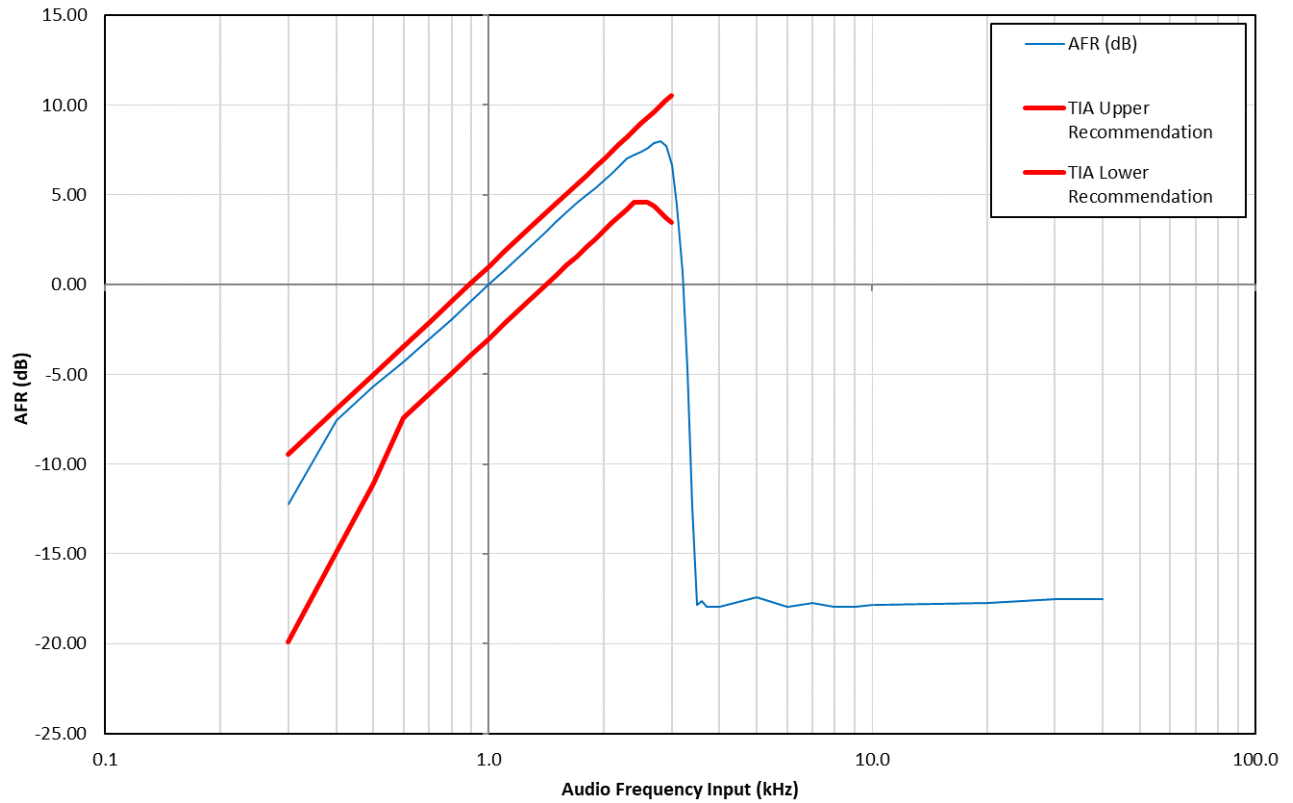

### 8.7.2 Low Pass Filter Response, Narrowband FM

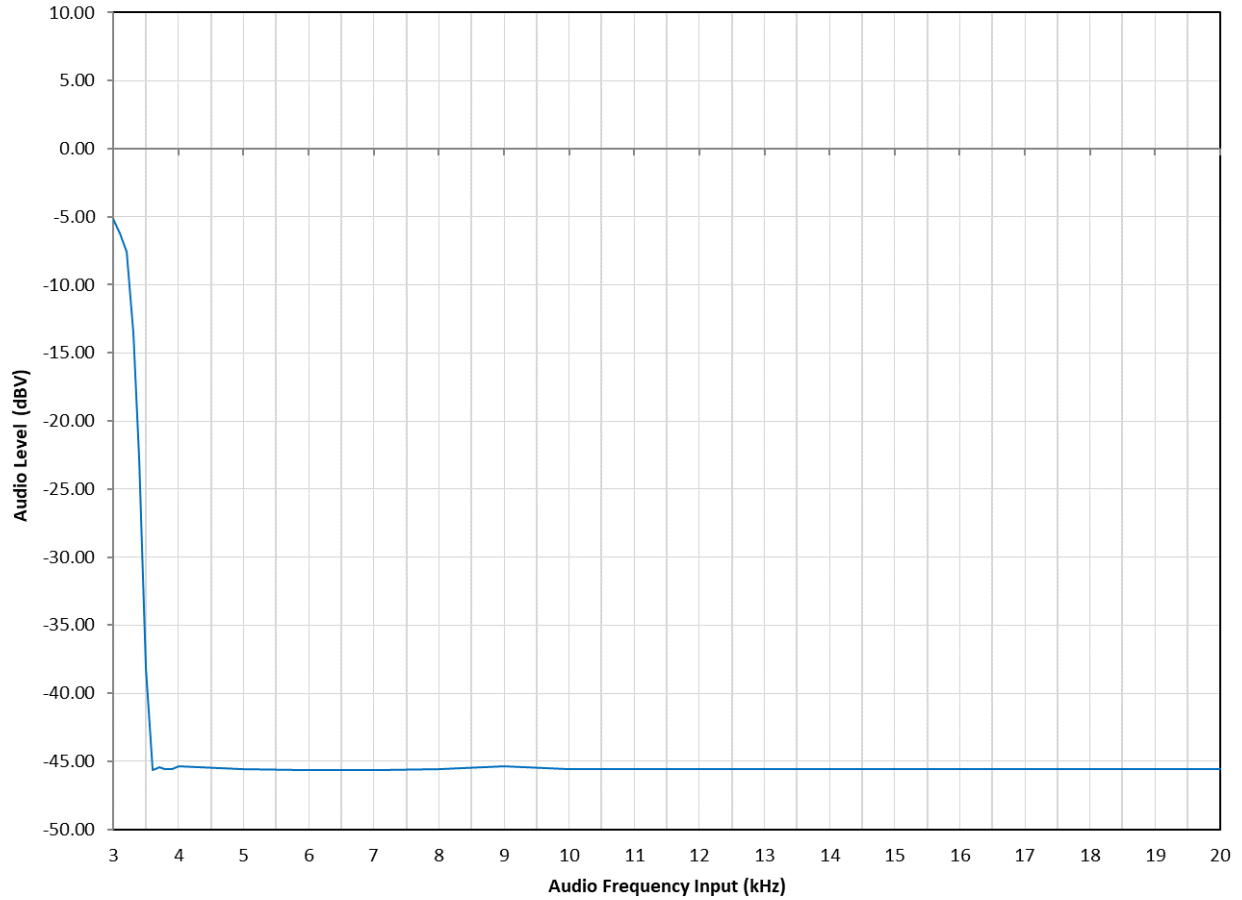

### 8.7.1 Low Pass Filter Response, Wideband FM

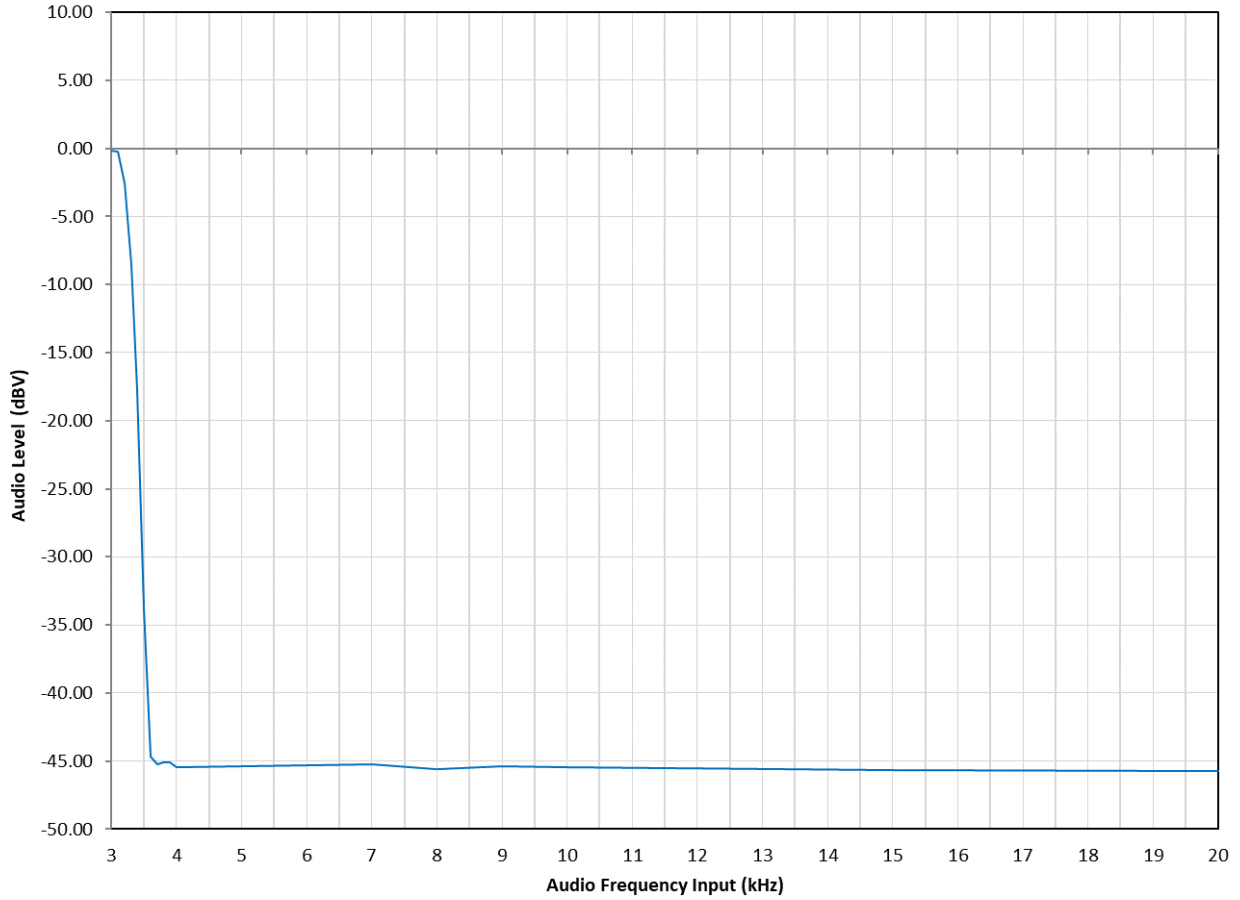

### 8.7.2 Modulation Limiting, Narrowband FM

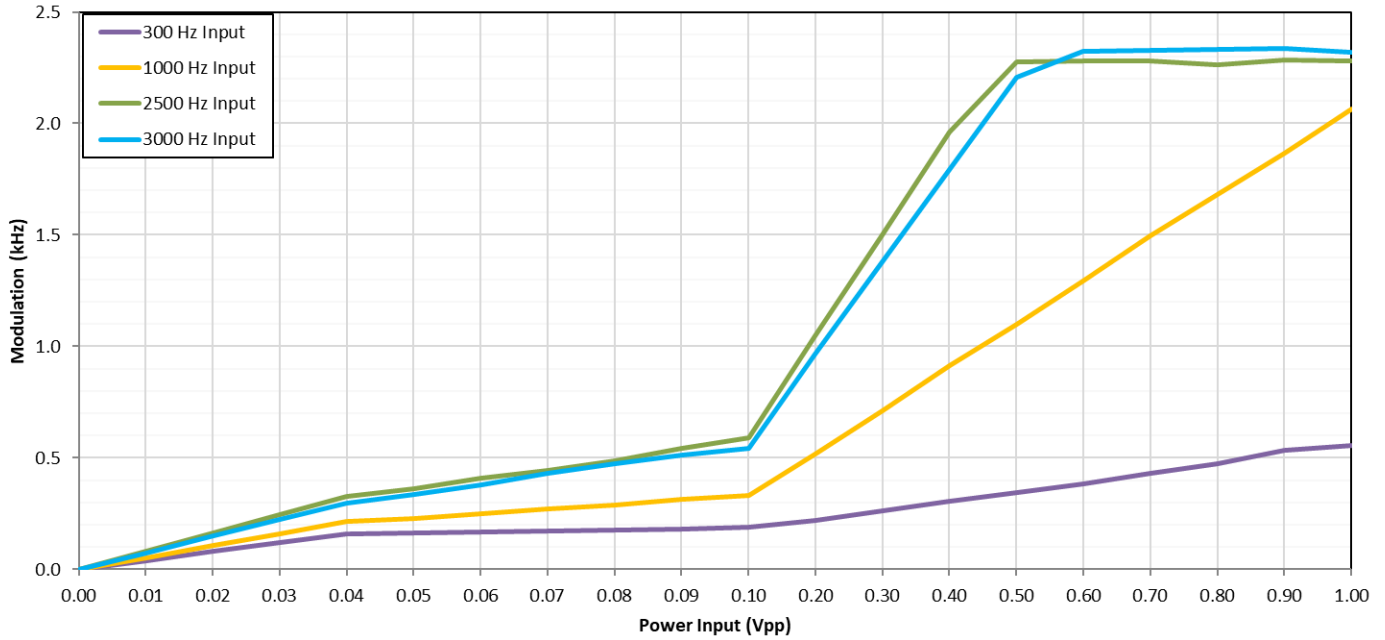

### 8.7.1 Modulation Limiting, Wideband FM

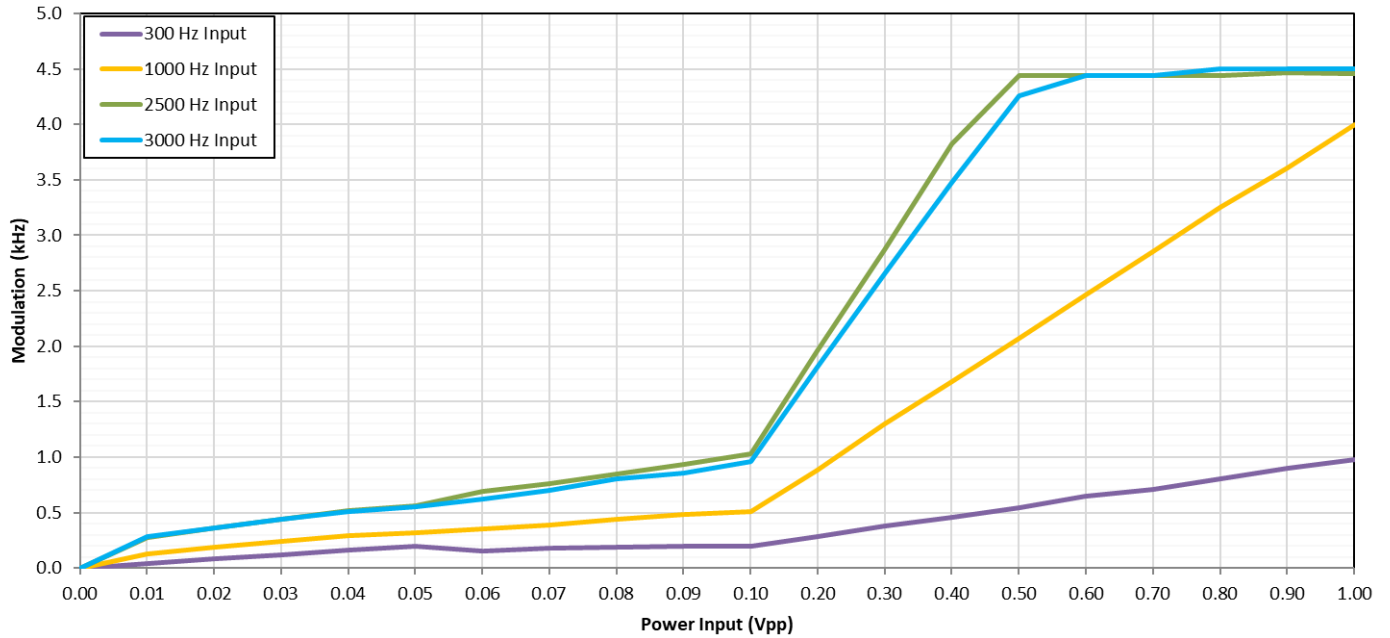

### 8.8 Frequency Stability

Limits from FCC Parts 2.1055, and 90.213; and test procedure from ANSI C63.26-2015.

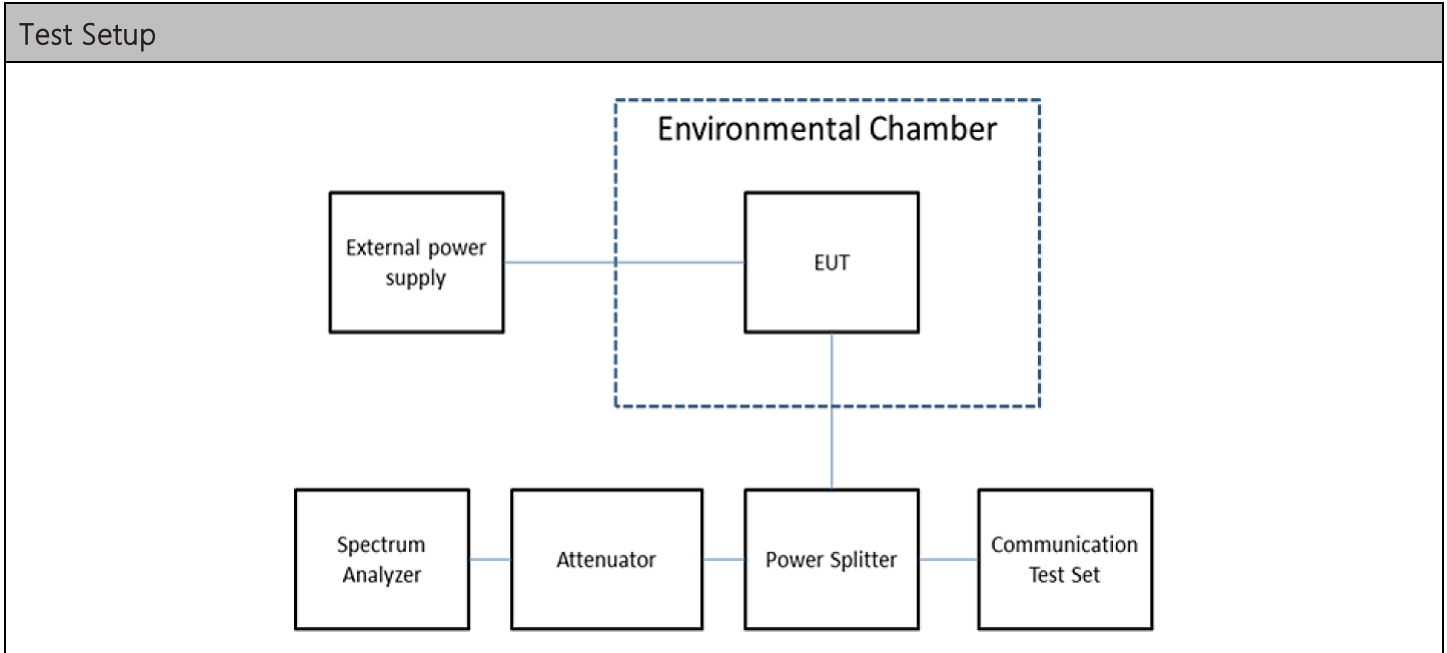

**Test Results, Mode 1**

Tuned Frequency (MHz)	Max Deviation (Hz)	Max Deviation (ppm)	Limit (ppm)
806.0125 MHz	4	0.00	0.10





Frequency Stability, Tabular Data

8.8.1 Frequency Stability Data

Limit (ppm)	0.1	ppm	
Limit, in Hz	81	Hz	
Lower Limit	806	MHz	
Upper Limit	806	MHz	
Rated Supply Voltage	120.0	<input checked="" type="radio"/> AC <input type="radio"/> DC	
Temperature / Voltage Variation			
Temperature (°C)	Supplied Voltage (V)	Frequency (MHz)	Deviation (Hz)
-30	120.0	806.012580	-4
-25	120.0	806.012579	-3
-20	120.0	806.012578	-2
-15	120.0	806.012580	-4
-10	120.0	806.012580	-4
-5	120.0	806.012580	-4
0	120.0	806.012579	-3
+5	120.0	806.012580	-4
+10	120.0	806.012579	-3
+15	120.0	806.012578	-2
+20 (reference)	120.0	806.012576	0
+20	102.0	806.012576	0
+20	138.0	806.012576	0
+25	120.0	806.012576	0
+30	120.0	806.012578	-2
+35	120.0	806.012578	-2
+40	120.0	806.012578	-2
+45	120.0	806.012580	-4
+50	120.0	806.012580	-4

### 8.8.2 Frequency Stability Plot

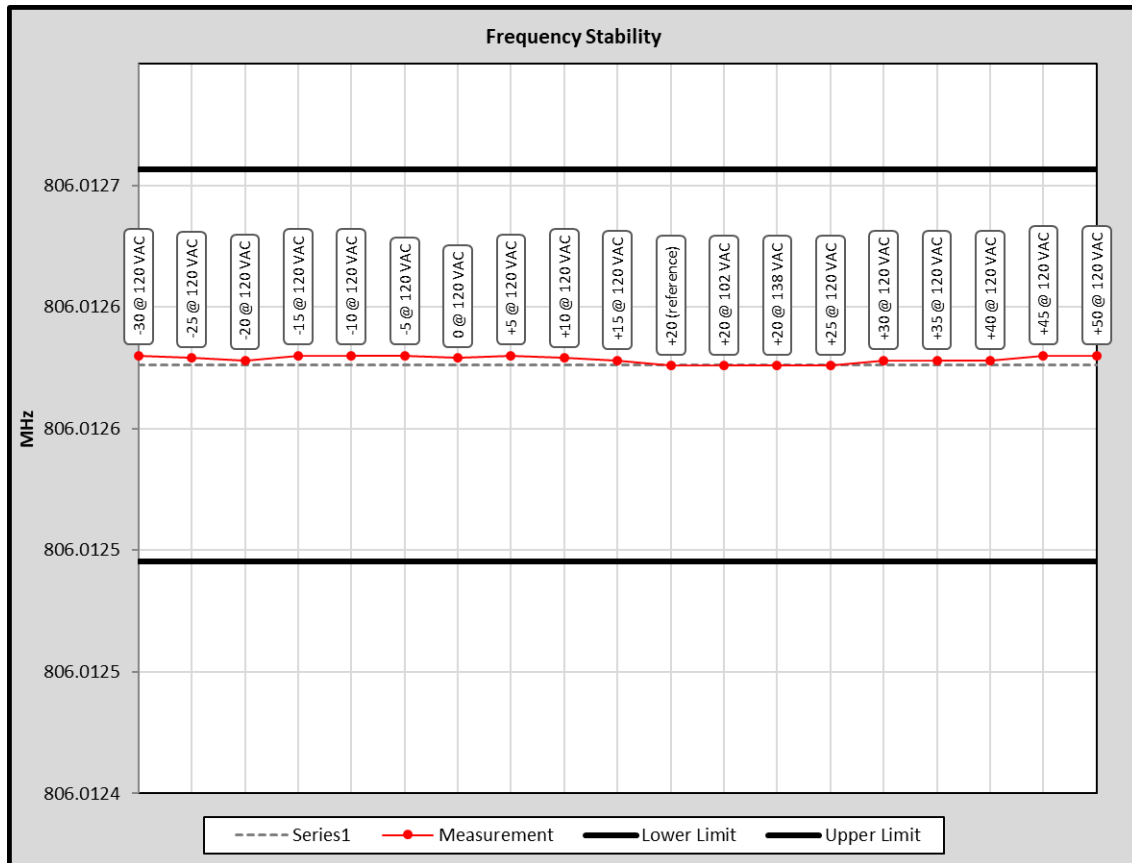

### 8.9 Transient Frequency Behavior

Limits from FCC Part 90.214; and test procedure from ANSI C63.26-2015.

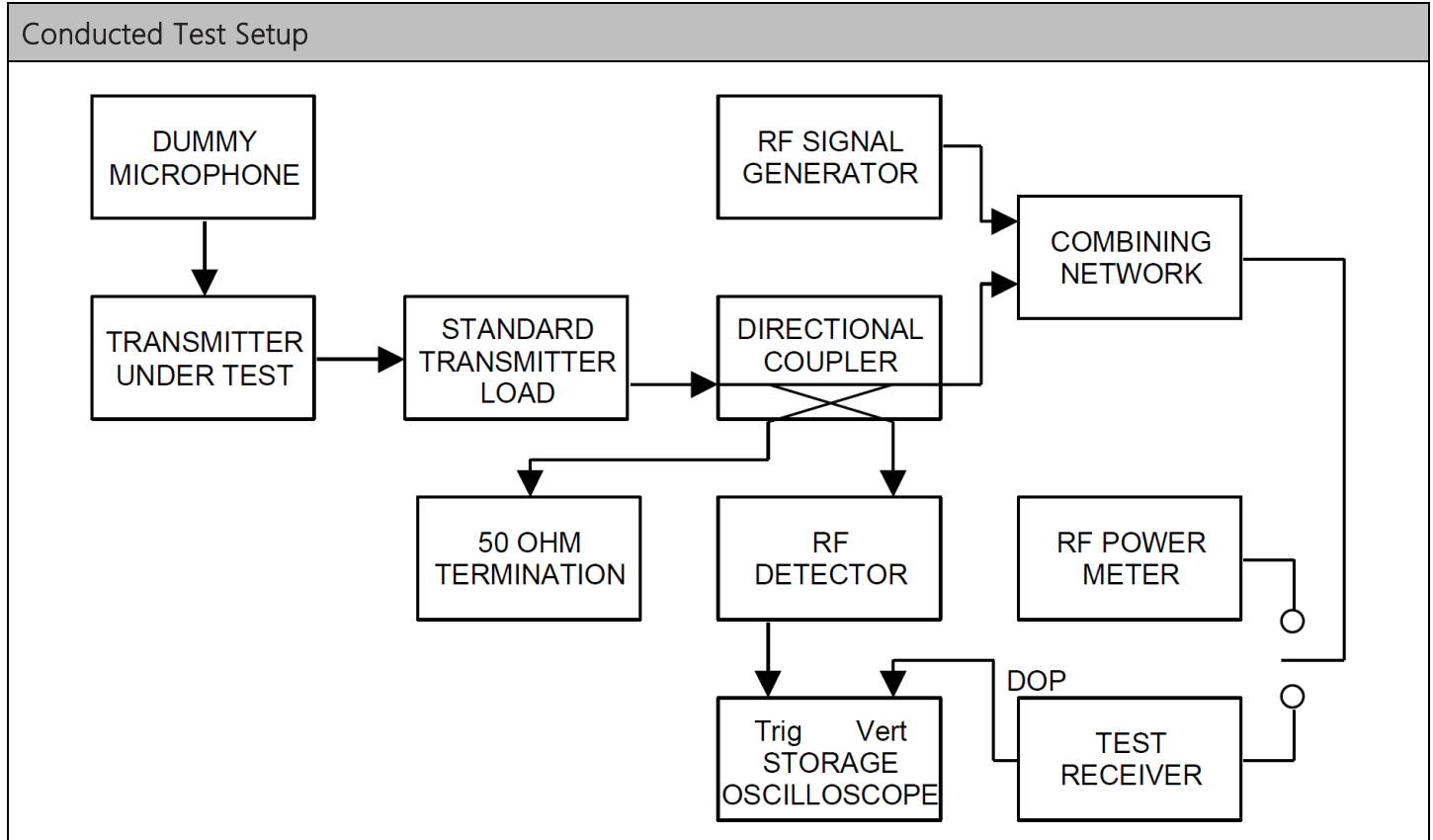

*n/a. EUT does not operate in frequency band which requires TFR.*

### 8.10 Adjacent channel power limits

Limits from FCC Part 90.221, and test procedure from ANSI C63.26-2015.

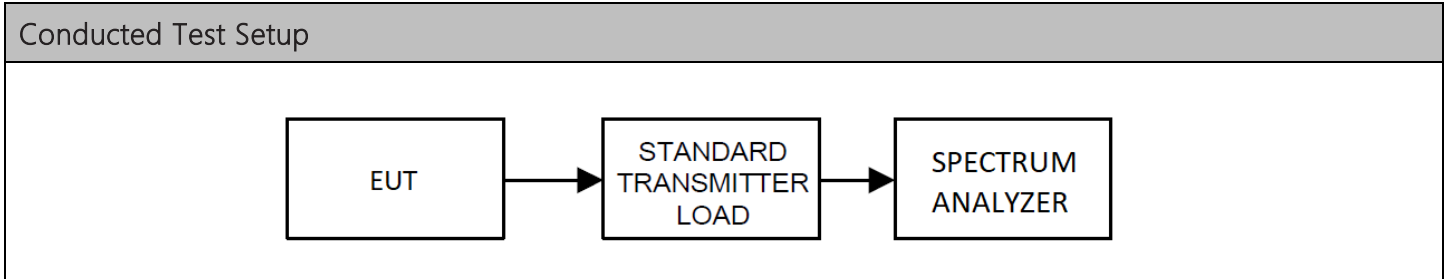

*n/a. EUT does not operate in frequency band which requires ACP.*



### 9. ANNEX-A - Photographs of the EUT

Photographs of the EUT and any manufacturer supplied accessories to be used with the EUT are in separate supplementary documents labelled EXTERNAL PHOTOS and INTERNAL PHOTOS.

### 10. ANNEX-B – Test Setup Photographs

Test setup photographs are located in a separate supplementary ANNEX-B document.

### 11. History of Test Report Changes

Test Report #	Revision #	Description	Date of Issue
TR_4164-20_FCC_PT90_1	1	Initial release	November 19, 2020
TR_4164-20_FCC_PT90_2	2	Clerical Updates	December 3, 2020



Timco Engineering, Inc., an IIA Company  
849 NW State Road 45, Newberry, Florida 32669  
(352) 472-5500 / [testing@timcoengr.com](mailto:testing@timcoengr.com)

---

END OF TEST REPORT

---