



## Dynamic Frequency Selection – Limited Test Report

### C9136I-(X)

### Cisco Catalyst C9136AX Series

(x = B)

FCC ID: LDKMU6CR2417

**5250-5350, 5470-5725 MHz**



Against the following Specifications:

CFR47 Part 15.407

Cisco Systems, Inc.

170 West Tasman Drive

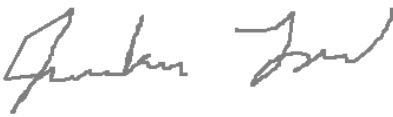
San Jose, CA 95134

	
<b>Author:</b> Julian Land <b>Tested By:</b> Julian Land	<b>Approved By:</b> Sam Kim <b>Title:</b> Manager – Radio Compliance & Certifications <b>Revision:</b> 1.2

This report replaces any previously entered test report under EDCS – **23819975**. This test report has been electronically authorized and archived using the CISCO Engineering Document Control system.

**SECTION 1: OVERVIEW.....3**

**SECTION 2: ASSESSMENT INFORMATION.....4**

2.1 GENERAL.....4

2.2 DATE OF TESTING.....6

2.3 REPORT ISSUE DATE.....6

2.4 TESTING FACILITIES .....6

2.5 EQUIPMENT ASSESSED (EUT).....6

**SECTION 3: RESULT SUMMARY.....7**

3.1 RESULTS SUMMARY TABLE.....7

**SECTION 4: SAMPLE DETAILS.....8**

4.1 SAMPLE DETAILS .....8

4.2 SYSTEM DETAILS .....8

4.3 MODE OF OPERATION DETAILS .....8

**APPENDIX A: DYNAMIC FREQUENCY SELECTION (DFS).....9**

A.1 UNII DEVICE DESCRIPTION.....9

A.2 DFS DETECTION THRESHOLDS.....10

A.3 RADAR TEST WAVEFORMS.....11

**APPENDIX B: DYNAMIC FREQUENCY SELECTION / TEST RESULTS.....15**

CALIBRATION PLOTS.....17

B.1 TEST PROCEDURE/RESULTS.....21

B.2 UNII DETECTION BANDWIDTH.....22

B.3 INITIAL CHANNEL AVAILABILITY CHECK TIME .....23

B.4 RADAR BURST AT THE BEGINNING OF THE CHANNEL AVAILABILITY CHECK TIME.....24

B.5 RADAR BURST AT THE END OF THE CHANNEL AVAILABILITY CHECK TIME .....25

B.6 IN-SERVICE MONITORING FOR CHANNEL MOVE TIME, CHANNEL CLOSING TRANSMISSION TIME AND NON-OCCUPANCY PERIOD.....26

B.7 STATISTICAL PERFORMANCE CHECK.....27

B.8 STATISTICAL PERFORMANCE CHECK – CAC DETECTION (ZERO WAIT DFS).....28

**APPENDIX C: LIST OF TEST EQUIPMENT USED TO PERFORM THE TEST .....64**

**APPENDIX D: PHOTOGRAPHS OF TEST SETUPS.....65**

**APPENDIX E: SOFTWARE USED TO PERFORM TESTING.....65**

**APPENDIX F: TEST PROCEDURES.....65**

**APPENDIX G: SCOPE OF ACCREDITATION (A2LA CERTIFICATE NUMBER 1178-01).....65**

**APPENDIX H: TEST ASSESSMENT PLAN.....65**

**APPENDIX I: WORST CASE JUSTIFICATION.....65**

**APPENDIX J: UUT SOFTWARE INFO .....65**

## **Section 1: Overview**

The samples were assessed against the tests detailed in section 3 under the requirements of the following specifications:

<b>Specifications:</b>
CFR47 Part 15.407

## Section 2: Assessment Information

### 2.1 General

This report contains an assessment of an apparatus against Electromagnetic Compatibility Standards based upon tests carried out on the samples submitted. The testing was performed by and for the use of Cisco Systems, Inc:

With regard to this assessment, the following points should be noted:

- a) The results contained in this report relate only to the items tested and were obtained in the period between the date of the initial assessment and the date of issue of the report. Manufactured products will not necessarily give identical results due to production and measurement tolerances.
- b) The apparatus was set up and exercised using the configuration and modes of operation defined in this report only.
- c) Where relevant, the apparatus was only assessed using the susceptibility criteria defined in this report and the Test Assessment Plan (TAP).
- d) All testing was performed under the following environmental conditions:

Temperature	17.8°C to 19.9°C (63.9°F to 67.9°F)
Atmospheric Pressure	1009.8mbar to 1031.7mbar
Humidity	39.7% to 56.6*%
- e) All AC testing was performed at one or more of the following supply voltages:

110V 60 Hz (+/-20%)
---------------------

### Units of Measurement

The units of measurements defined in the appendices are reported in specific terms, which are test dependent. Where radiated measurements are concerned these are defined at a particular distance. Basic voltage measurements are defined in units of [dBuV]

As an example, the basic calculation for all measurements is as follows:

$$\text{Emission level [dBuV]} = \text{Indicated voltage level [dBuV]} + \text{Cable Loss [dB]} + \text{Other correction factors [dB]}$$

The combinations of correction factors are dependent upon the exact test configurations [see test equipment lists for further details] and may include:-

Antenna Factors, Pre Amplifier Gain, LISN Loss, Pulse Limiter Loss and Filter Insertion Loss..

Note: to convert the results from dBuV/m to uV/m use the following formula:-

$$\text{Level in uV/m} = \text{Common Antilogarithm} [(X \text{ dBuV/m})/20] = Y \text{ uV/m}$$

Measurement Uncertainty Values

voltage and power measurements	± 2 dB
conducted EIRP measurements	± 1.4 dB
radiated measurements	± 3.2 dB
frequency measurements	± 2.4 10 <sup>-7</sup>
temperature measurements	± 0.54°
humidity measurements	± 2.3%
DC and low frequency measurements	± 2.5%

Where relevant measurement uncertainty levels have been estimated for tests performed on the apparatus. This uncertainty represents an expanded uncertainty expressed at approximately the 95% confidence level using a coverage factor of k=2.

Radiated emissions (expanded uncertainty, confidence interval 95%)

30 MHz - 300 MHz	+/- 3.8 dB
300 MHz - 1000 MHz	+/- 4.3 dB
1 GHz - 10 GHz	+/- 4.0 dB
10 GHz - 18GHz	+/- 8.2 dB
18GHz - 26.5GHz	+/- 4.1 dB
26.5GHz - 40GHz	+/- 3.9 dB

Conducted emissions (expanded uncertainty, confidence interval 95%)

30 MHz – 40GHz	+/- 0.38 dB
----------------	-------------

A product is considered to comply with a requirement if the nominal measured value is below the limit line.  
 The product is considered to not be in compliance in case the nominal measured value is above the limit line.

This report must not be reproduced except in full, without written approval of Cisco Systems, Inc..

**2.2 Date of testing**

1/26/2023 – 1/31/2023

**2.3 Report Issue Date**

3/24/2023

Cisco uses an electronic system to issue, store and control the revision of test reports. This system is called the Engineering Document Control System. The actual report issue date is embedded into the original file on EDCS. Any copies of this report, either electronic or paper, that are not on EDCS must be considered uncontrolled.

**2.4 Testing facilities**

This assessment was performed by:

**Testing Laboratory**

Cisco Systems, Inc.,  
125 West Tasman Drive  
San Jose, CA 95134, USA

**Registration Numbers for Industry Canada**

<b>Cisco System Site</b>	<b>Address</b>	<b>Site Identifier</b>
Building P, 10m Chamber	125 West Tasman Dr San Jose, CA 95134	Company #: 2461N-2
Building P, 5m Chamber	125 West Tasman Dr San Jose, CA 95134	Company #: 2461N-1

**Test Engineers**

Julian Land

**2.5 Equipment Assessed (EUT)**

C9136I-B

**Section 3: Result Summary****3.1 Results Summary Table**

<b>Basic Standard</b>	<b>Technical Requirements / Details</b>	<b>Result</b>
FCC 15.407	Dynamic Frequency Selection (DFS) Detection Threshold	Not covered by the scope of this report
FCC 15.407	Channel Availability Check Time	Not covered by the scope of this report
FCC 15.407	Channel Move Time	Not covered by the scope of this report
FCC 15.407	Channel Closing Time	Not covered by the scope of this report
FCC 15.407	Non-Occupancy Period	Not covered by the scope of this report
FCC 15.407	U-NII Detection Bandwidth	Not covered by the scope of this report
TCB Workshop Guidance	CAC detection (Zero Wait DFS)	Pass

Note: This is a supplementary test report to cover the Zero Wait feature. Please refer to EDCS 22709517 for additional DFS test results.

### Section 4: Sample Details

Note: Each sample was evaluated to ensure that its condition was suitable to be used as a test sample prior to the commencement of testing.

#### 4.1 Sample Details

Sample No.	Equipment Details	Manufacturer	Hardware Rev.	Firmware Rev.	Software Rev.	Serial Number
S01	C9136I-B	Cisco Systems, Inc	A0	NSS.HK.11.3.c 2-2-E_custC	Sat Nov 26 00:25:58 GMT 2022 cheetah-build9 /san1/BUILD/workspa ce/master- cisco_mfg/label/mfg- ap1g6a	FOC26071SE6
S02	Support Laptop	Lenovo	T490	NA	NA	NA

#### 4.2 System Details

System Number	Description	Sample Description	Samples	System under test	Support equipment
1	Zero Wait DFS Testing Used for 20 and 80MHz testing	C9136I-B	S01	<input checked="" type="checkbox"/>	<input type="checkbox"/>
		Support Laptop	S02	<input type="checkbox"/>	<input checked="" type="checkbox"/>

#### 4.3 Mode of Operation Details

Mode#	Description	Comments
1	Zero Wait DFS Tests Dual Radio	AP configured for one channel, future channel assigned, radar applied to the future channel
2	Zero Wait DFS Tests Tri Radio – D1	AP configured for one channel, future channel assigned, radar applied to the future channel
3	Zero Wait DFS Tests Tri Radio – D2	AP configured for one channel, future channel assigned, radar applied to the future channel



## Appendix A: Dynamic Frequency Selection (DFS)

15.407: U-NII devices operating in the 5.25-5.35 GHz band and the 5.47-5.725 GHz band shall employ a TPC mechanism. The U-NII device is required to have the capability to operate at least 6 dB below the mean EIRP value of 30 dBm. A TPC mechanism is not required for systems with an e.i.r.p. of less than 500 mW.

U-NII devices operating in the 5.25-5.35 GHz and 5.47-5.725 GHz bands shall employ a DFS radar detection mechanism to detect the presence of radar systems and to avoid co-channel operation with radar systems.

### A.1 UNII Device Description

Refer to the Radio Theory of Operation for supported modes. The modes included in this report represent the worst-case data for all modes.

The following antennas are supported by this product series.

The data included in this report represent the worst-case data for all antennas.

Frequency	Part Number	Antenna Type	Antenna Gain (dBi)
5GHz	NA	Internal, Tri-band Omni-directional	5

1. Of the modes tested, the maximum EIRP of the 5GHz equipment is 28.34dBm, and the minimum possible EIRP is 4.24dBm.

Below are the available 50ohm antenna assemblies and their corresponding gains. 0dBi gain was used to set the -63 dBm threshold level (-64dBm +1 dB) during calibration of the test setup.

2. System testing was performed with IPERF traffic that streams continuously from the Master to the Client IP based system.
3. The Master cycle time was not evaluated in this report, initial CAC testing was covered in a separate report.
4. Information regarding the parameters of the detected Radar Waveforms is not available to the end user.
5. For the 5250-5350 MHz and 5470-5725 MHz bands, the Master device provides, on aggregate, uniform loading of the spectrum across all devices by selecting an operating channel among the available channels using a random algorithm.

**A.2 DFS Detection Thresholds**

1. **Interference Threshold values, Master or Client incorporating In-Service Monitoring**

Maximum Transmit Power	Value (See Notes 1, 2, and 3)
EIRP $\geq$ 200 milliwatt	-64 dBm
EIRP < 200 milliwatt and power spectral density < 10 dBm/MHz	-62 dBm
EIRP < 200 milliwatt that do not meet the power spectral density requirement	-64 dBm
<p><b>Note 1:</b> This is the level at the input of the receiver assuming a 0 dBi receive antenna.  <b>Note 2:</b> Throughout these test procedures an additional 1 dB has been added to the amplitude of the test transmission waveforms to account for variations in measurement equipment. This will ensure that the test signal is at or above the detection threshold level to trigger a DFS response.  <b>Note 3:</b> EIRP is based on the highest antenna gain. For MIMO devices refer to KDB Publication 662911 D01 v02r01.</p>	

2. **DFS Response requirement values**

Parameter	Value
<i>Non-occupancy period</i>	Minimum 30 minutes
<i>Channel Availability Check Time</i>	60 seconds
<i>Channel Move Time</i>	10 seconds See Note 1.
<i>Channel Closing Transmission Time</i>	200 milliseconds + an aggregate of 60 milliseconds over remaining 10 second period. See Notes 1 and 2.
<i>U-NII Detection Bandwidth</i>	Minimum 100% of the U-NII 99% transmission power bandwidth. See Note 3.
<p><b>Note 1:</b> <i>Channel Move Time</i> and the <i>Channel Closing Transmission Time</i> should be performed with Radar Type 0. The measurement timing begins at the end of the Radar Type 0 burst.  <b>Note 2:</b> The <i>Channel Closing Transmission Time</i> is comprised of 200 milliseconds starting at the beginning of the <i>Channel Move Time</i> plus any additional intermittent control signals required to facilitate a <i>Channel</i> move (an aggregate of 60 milliseconds) during the remainder of the 10 second period. The aggregate duration of control signals will not count quiet periods in between transmissions.  <b>Note 3:</b> During the <i>U-NII Detection Bandwidth</i> detection test, radar type 0 should be used. For each frequency step the minimum percentage of detection is 90 percent. Measurements are performed with no data traffic.</p>	

### A.3 Radar Test Waveforms

This section provides the parameters for required test waveforms, minimum percentage of successful detections, and the minimum number of trials that must be used for determining DFS conformance. Step intervals of 0.1 microsecond for Pulse Width, 1 microsecond for PRI, 1 MHz for chirp width and 1 for the number of pulses will be utilized for the random determination of specific test waveforms.

#### 1. Short Pulse Radar Test Waveforms

Radar Type	Pulse Width (μsec)	PRI (μsec)	Number of Pulses	Minimum Percentage of Successful Detection	Minimum Numbers of Trials
0	1	1428	18	See Note 1	See Note 1
1	1	Test A: 15 unique PRI values randomly selected from the list of 23 PRI values in Table 5a	Roundup $\left\{ \left( \frac{1}{360} \right) \cdot \left( \frac{19 \cdot 10^6}{\text{PRI}_{\mu\text{sec}}} \right) \right\}$	60%	30
		Test B: 15 unique PRI values randomly selected within the range of 518-3066 μsec, with a minimum increment of 1 μsec, excluding PRI values selected in Test A			
2	1-5	150-230	23-29	60%	30
3	6-10	200-500	16-18	60%	30
4	11-20	200-500	12-16	60%	30
Aggregate (Radar Types 1-4)				80%	120
<p><b>Note 1:</b> Short Pulse Radar Type 0 shall only be used for the channel availability and detection bandwidth tests. It should be noted that any of the radar test waveforms 0 – 4 can be used for the channel availability and detection bandwidth tests.</p>					

A minimum of 30 unique waveforms are required for each of the Short Pulse Radar Types 2 through 4. If more than 30 waveforms are used for Short Pulse Radar Types 2 through 4, then each additional waveform must also be unique and not repeated from the previous waveforms. If more than 30 waveforms are used for Short Pulse Radar Type 1, then each additional waveform is generated with Test B and must also be unique and not repeated from the previous waveforms in Tests A or B.

For example, if in Short Pulse Radar Type 1 Test B a PRI of 3066  $\mu$ sec is selected, the number of pulses would be  $\text{Roundup} \left\{ \left( \frac{1}{360} \right) \cdot \left( \frac{19 \cdot 10^6}{3066} \right) \right\} = \text{Roundup} \{ 17.2 \} = 18$

**Table 5a – Pulse Repetition Intervals Values for Test A**

Pulse Repetition Frequency Number	Pulse Repetition Frequency (Pulses Per Second)	Pulse Repetition Interval (Microseconds)
1	1930.5	518
2	1858.7	538
3	1792.1	558
4	1730.1	578
5	1672.2	598
6	1618.1	618
7	1567.4	638
8	1519.8	658
9	1474.9	678
10	1432.7	698
11	1392.8	718
12	1355.0	738
13	1319.3	758
14	1285.3	778
15	1253.1	798
16	1222.5	818
17	1193.3	838
18	1165.6	858
19	1139.0	878
20	1113.6	898
21	1089.3	918
22	1066.1	938
23	326.2	3066

The aggregate is the average of the percentage of successful detections of Short Pulse Radar Types 1-4. For example, the following table indicates how to compute the aggregate of percentage of successful detections.

Radar Type	Number of Trials	Number of Successful Detections	Minimum Percentage of Successful Detection
1	35	29	82.9%
2	30	18	60%
3	30	27	90%
4	50	44	88%
Aggregate (82.9% + 60% + 90% + 88%)/4 = 80.2%			

**2. Long Pulse Radar Test Waveform**

Radar Type	Pulse Width (µsec)	Chirp Width (MHz)	PRI (µsec)	Number of Pulses per Burst	Number of Bursts	Minimum Percentage of Successful Detection	Minimum Trials
5	50-100	5-20	1000- 2000	1-3	8-20	80%	30

The parameters for this waveform are randomly chosen. Thirty unique waveforms are required for the Long Pulse radar test signal. If more than 30 waveforms are used for the Long Pulse radar test signal, then each additional waveform must also be unique and not repeated from the previous waveforms.

Each waveform is defined as follows:

- 1) The transmission period for the Long Pulse Radar test signal is 12 seconds.
- 2) There are a total of 8 to 20 Bursts in the 12 second period, with the number of Bursts being randomly chosen. This number is Burst Count.
- 3) Each Burst consists of 1 to 3 pulses, with the number of pulses being randomly chosen. Each Burst within the 12 second sequence may have a different number of pulses.
- 4) The pulse width is between 50 and 100 microseconds, with the pulse width being randomly chosen. Each pulse within a Burst will have the same pulse width. Pulses in different Bursts may have different pulse widths.
- 5) Each pulse has a linear FM chirp between 5 and 20 MHz, with the chirp width being randomly chosen. Each pulse within a Burst will have the same chirp width. Each pulse within a transmission period will have the same chirp width. The chirp is centered on the pulse. For example, with a radar frequency of 5300 MHz and a 20 MHz chirped signal, the chirp starts at 5290 MHz and ends at 5310 MHz.
- 6) If more than one pulse is present in a Burst, the time between the pulses will be between 1000 and 2000 microseconds, with the time being randomly chosen. If three pulses are present in a Burst, the time between the first and second pulses is chosen independently of the time between the second and third pulses.
- 7) The 12 second transmission period is divided into even intervals. The number of intervals is equal to Burst Count. Each interval is of length  $(12,000,000 / \text{Burst Count})$  microseconds. Each interval contains one Burst. The start time for the Burst, relative to the beginning of the interval, is between 1 and  $[(12,000,000 / \text{Burst Count}) - (\text{Total Burst Length}) + (\text{One Random PRI Interval})]$  microseconds, with the start time being randomly chosen. The step interval for the start time is 1 microsecond. The start time for each Burst is chosen randomly.

**A representative example of a Long Pulse radar test waveform:**

- 1) The total test signal length is 12 seconds.
- 2) 8 Bursts are randomly generated for the Burst Count.
- 3) Burst 1 has 2 randomly generated pulses.
- 4) The pulse width (for both pulses) is randomly selected to be 75 microseconds.
- 5) The PRI is randomly selected to be at 1213 microseconds.
- 6) Bursts 2 through 8 are generated using steps 3 – 5.
- 7) Each Burst is contained in even intervals of 1,500,000 microseconds. The starting location for Pulse 1, Burst 1 is randomly generated (1 to 1,500,000 minus the total Burst 1 length + 1 random PRI interval) at the 325,001 microsecond step. Bursts 2 through 8 randomly fall in successive 1,500,000 microsecond intervals (i.e. Burst 2 falls in the 1,500,001 – 3,000,000 microsecond range).

**Graphical Representation of a Long Pulse radar Test Waveform**

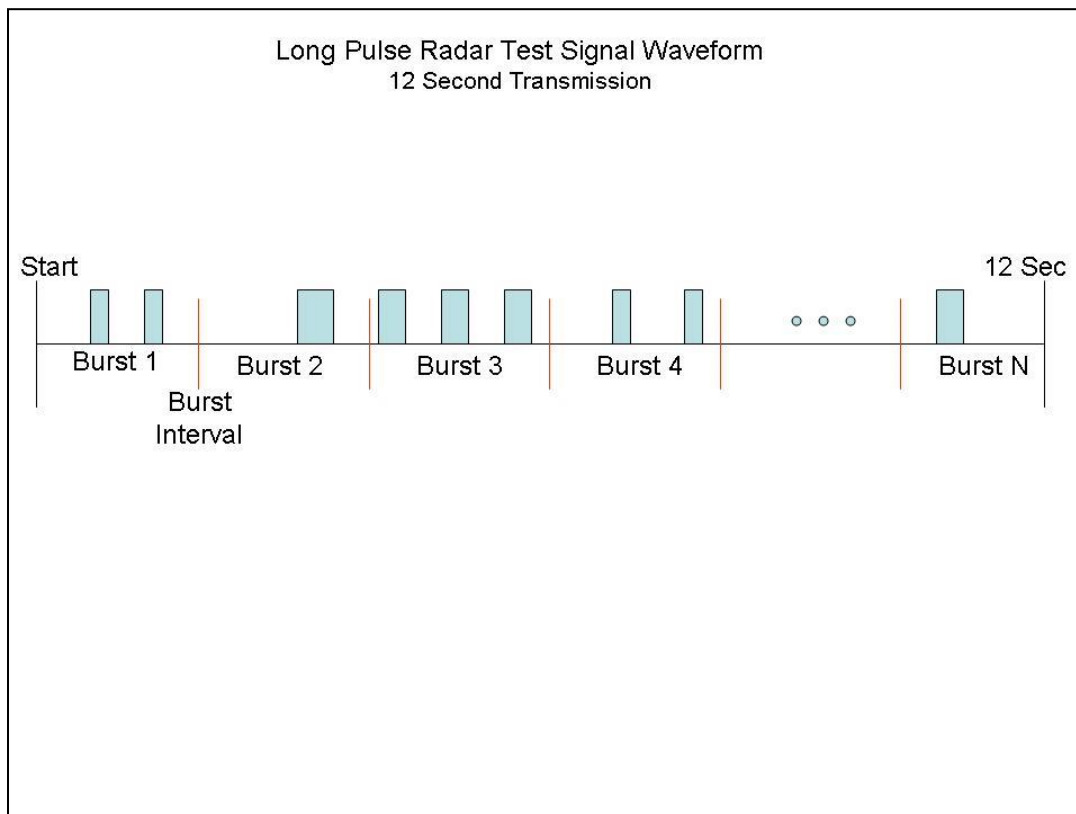

**3. Long Pulse Radar Test Waveform**

Radar Type	Pulse Width (µsec)	PRI (µsec)	Pulses per Hop	Hopping Rate (kHz)	Hopping Sequence Length (msec)	Minimum Percentage of Successful Detection	Minimum Trials
6	1	333	9	.333	300	70%	30

For the Frequency Hopping Radar Type, the same *Burst* parameters are used for each waveform. The hopping sequence is different for each waveform and a 100-length segment is selected<sup>1</sup> from the hopping sequence defined by the following algorithm:

The first frequency in a hopping sequence is selected randomly from the group of 475 integer frequencies from 5250 – 5724 MHz. Next, the frequency that was just chosen is removed from the group and a frequency is randomly selected from the remaining 474 frequencies in the group. This process continues until all 475 frequencies are chosen for the set. For selection of a random frequency, the frequencies remaining within the group are always treated as equally likely.

**Appendix B: Dynamic Frequency Selection / Test Results**

**Standards Reference**

FCC 15.407

**Test Procedure**

Ref. KDB 905462 D02 UNII DFS Compliance Procedures New Rules v02

DFS Test parameters
Span = 0 Hz
RBW ≥ 3 MHz
VBW ≥ 3 MHz
Detector = Peak
Trace = Single Sweep

**Samples, Systems, and Modes**

System Number	Description	Samples	System under test	Support equipment
1	EUT	S01	<input checked="" type="checkbox"/>	<input type="checkbox"/>
	Support	S02	<input type="checkbox"/>	<input checked="" type="checkbox"/>

<b>Tested By:</b> Julian Land	<b>Date of testing:</b> 26-Jan-2023 - 31-Jan-2023
<b>Test Result: PASS</b>	

**Test Equipment**

See Appendix C for list of test equipment

The following equipment setup was used to calibrate the conducted Radar Waveform. A spectrum analyzer was used to establish the test signal level for each radar type. During this process there were no transmissions by either the Master or Client Device. The spectrum analyzer was switched to the zero span (Time Domain) mode at the frequency of the Radar Waveform generator. Peak detection was utilized. The spectrum analyzer resolution bandwidth (RBW) and video bandwidth (VBW) were set to 3 MHz.

The signal generator amplitude was set so that the power level measured at the spectrum analyzer was -60dBm.

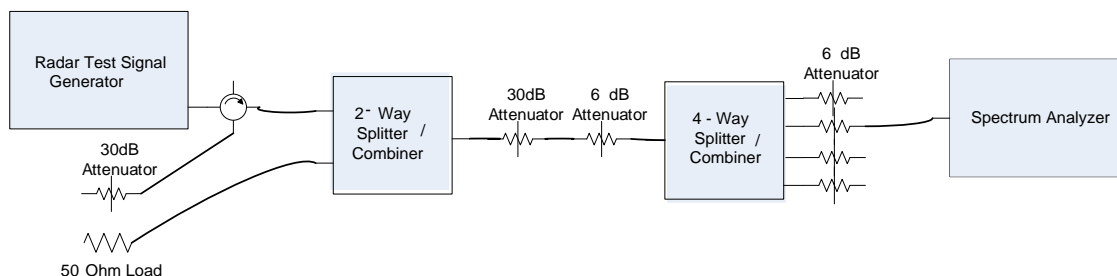

**Conducted Calibration Setup**



### Calibration Plots

Following are the calibration plots for each of the required radar waveforms.

#### Calibration Plots – Zero Wait DFS - Bandwidth 20

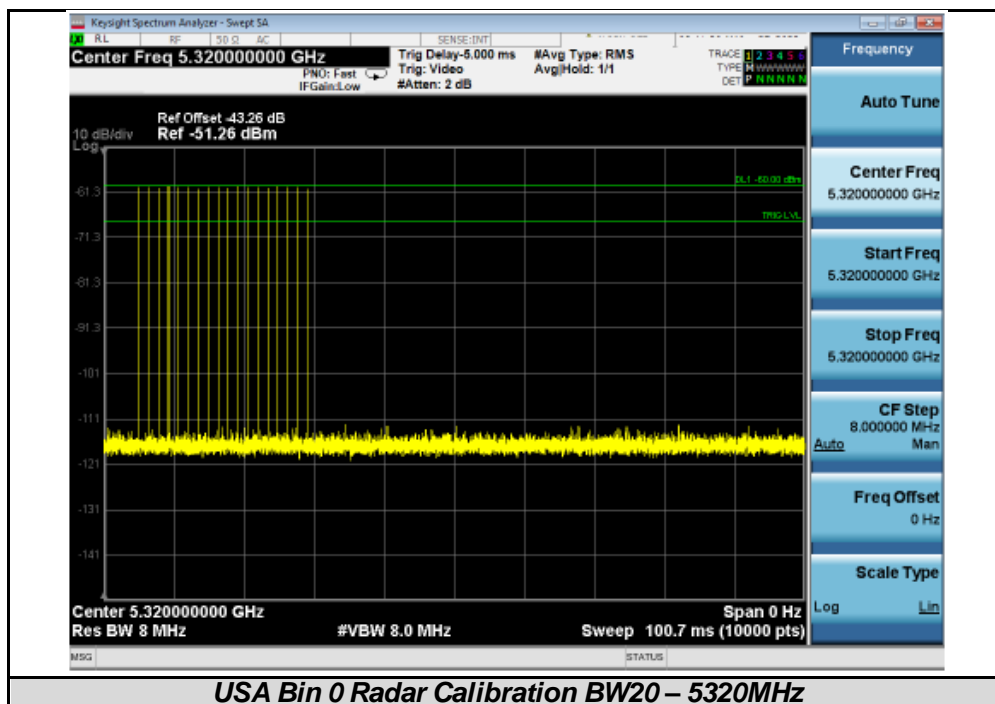
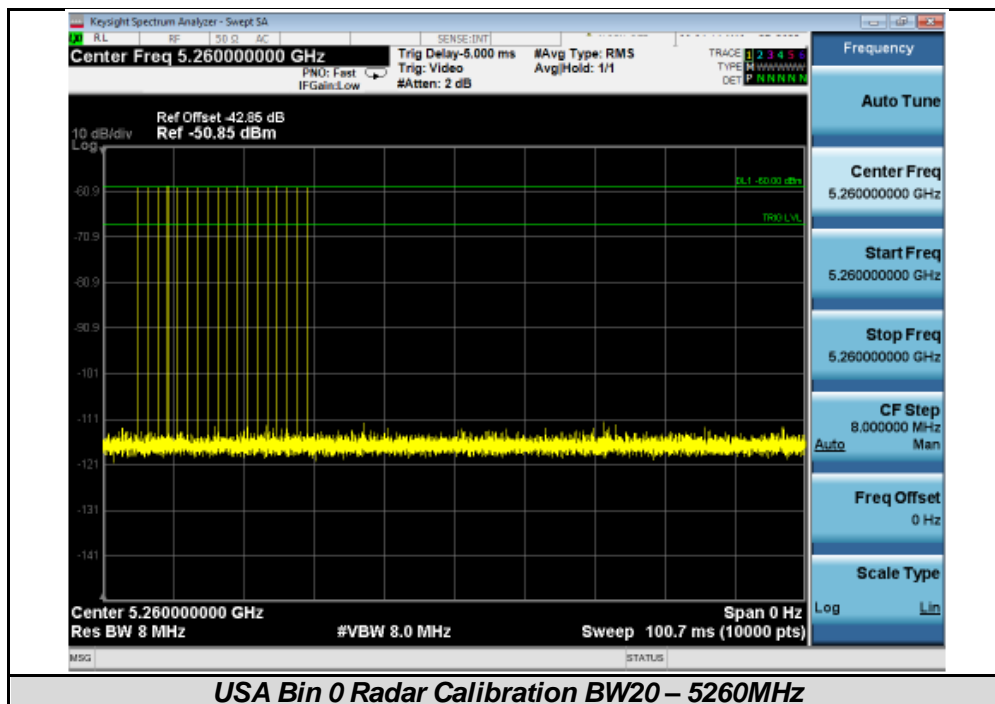

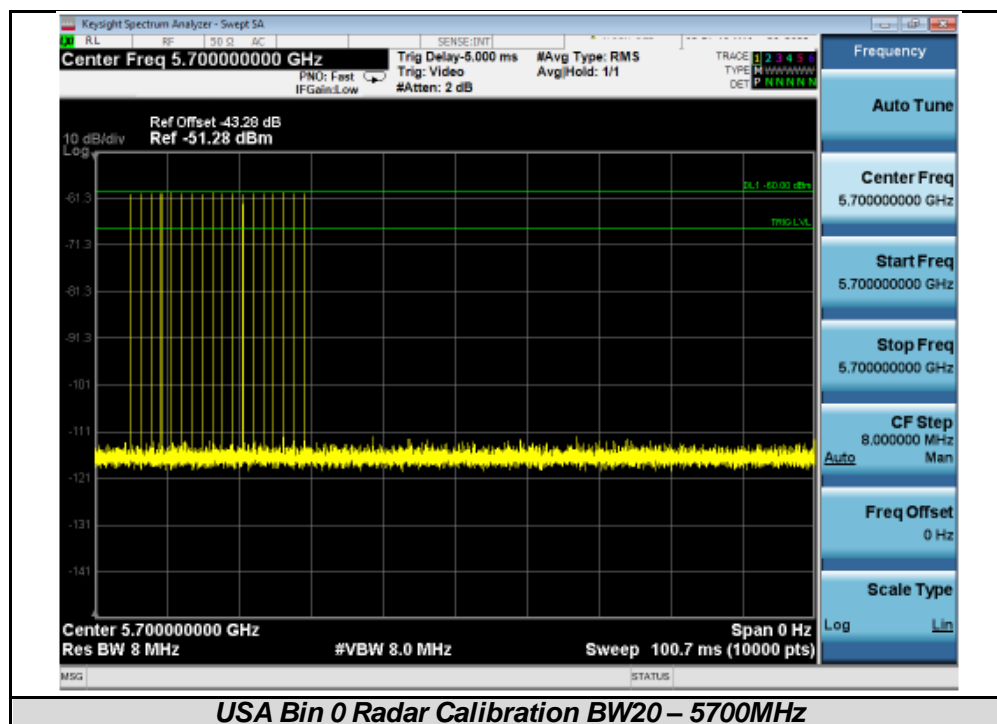
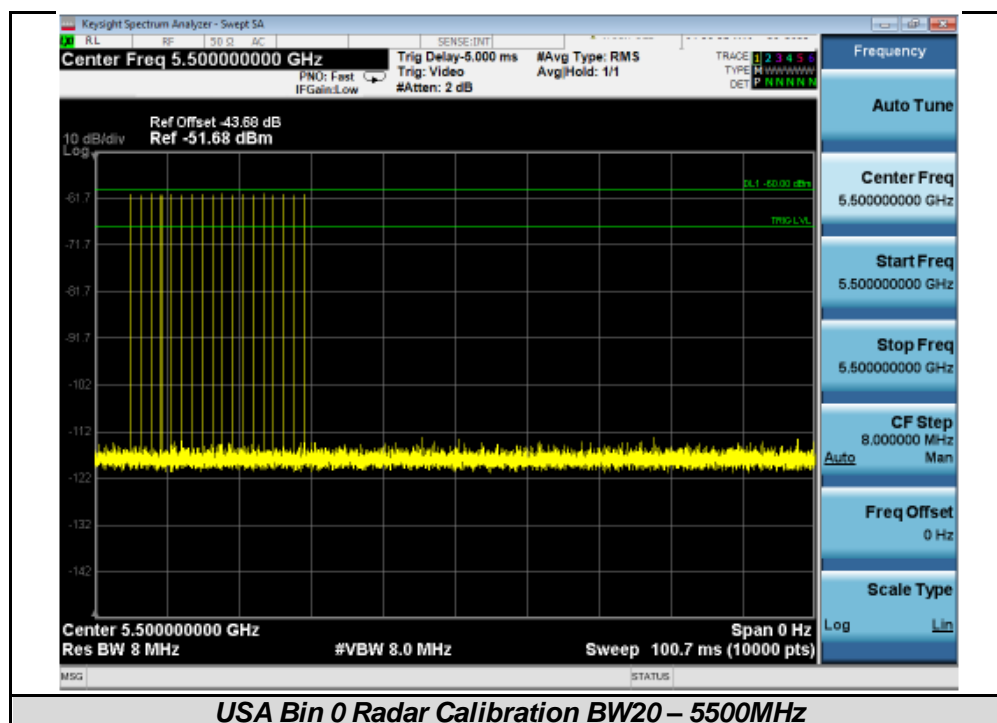

**Calibration Plots – Zero Wait DFS - Bandwidth 80**

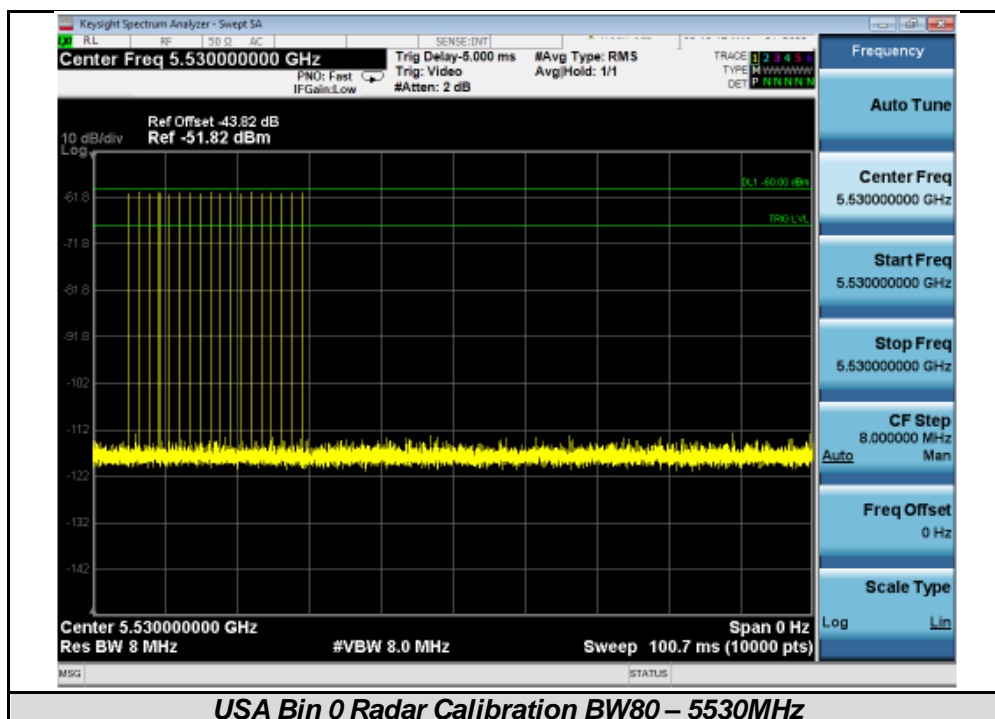
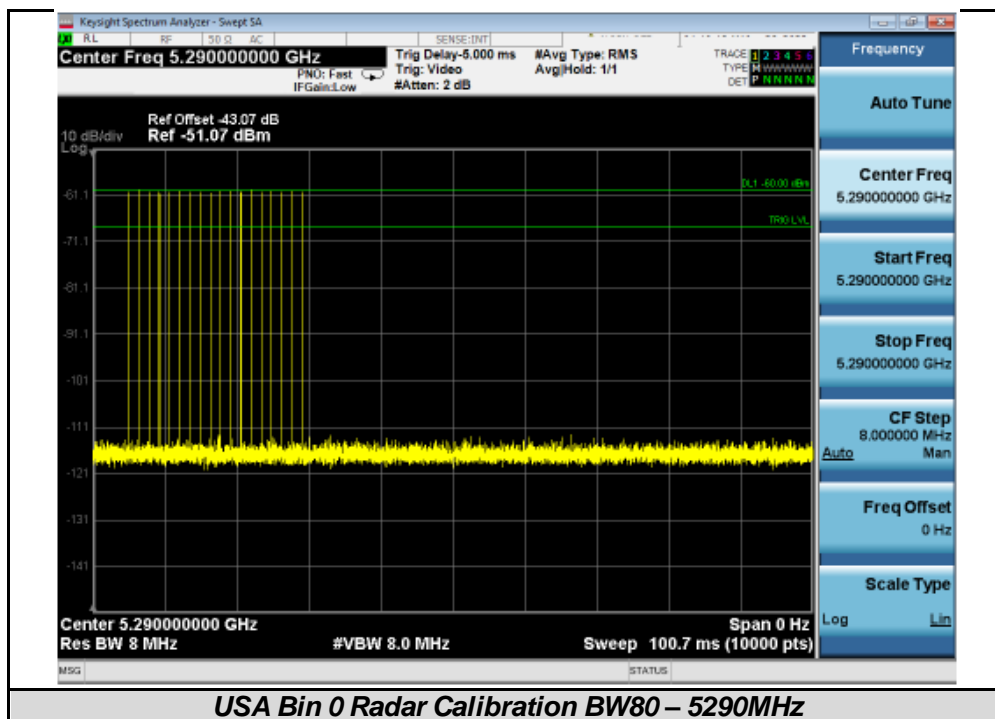

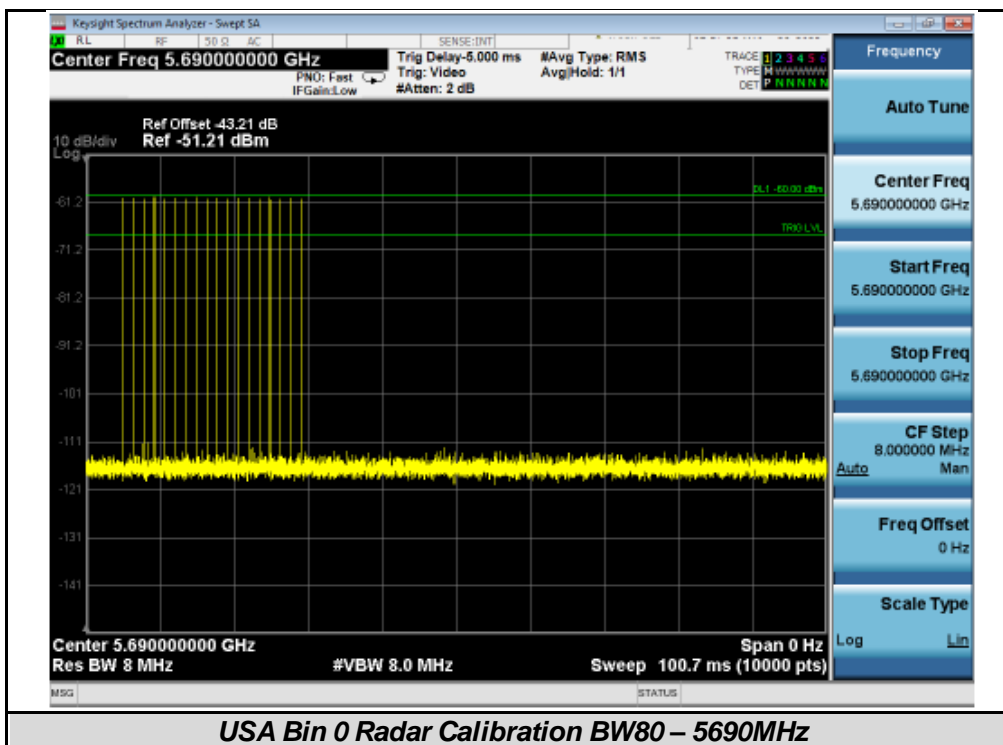

**B.1 Test Procedure/Results**

A spectrum analyzer is used as a monitor to verify that the UUT has vacated the Channel within the (Channel Closing Transmission Time and Channel Move Time) and does not transmit on a Channel during the Non-Occupancy Period after the detection and Channel move. It is also used to monitor UUT transmissions during the Channel Availability Check Time.

Following is the test setup used to generate the Radar Waveforms, and for all DFS tests described herein.

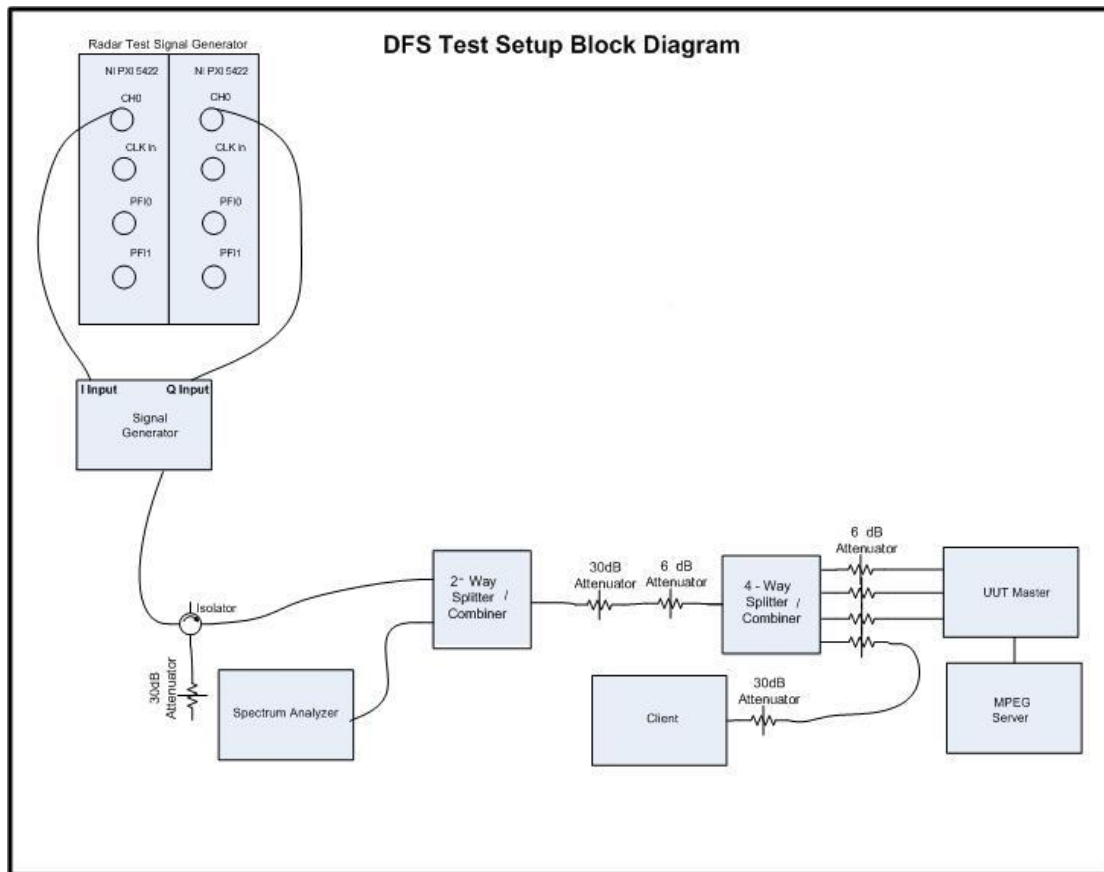

**Conducted Setup: Radar Test Waveforms are injected into the Master**

**B.2 UNII Detection Bandwidth**

Covered in EDCS# 22709517

**B.3 Initial Channel Availability Check Time**

Covered in EDCS# 22709517

**B.4 Radar Burst at the Beginning of the Channel Availability Check Time**

Covered in EDCS# 22709517



**B.5 Radar Burst at the End of the Channel Availability Check Time**

Covered in EDCS# 22709517



**B.6 In-Service Monitoring for Channel Move Time, Channel Closing Transmission Time and Non-Occupancy Period**

Covered in EDCS# 22709517

**B.7 Statistical Performance Check**

Covered in EDCS# 22709517

### **B.8 Statistical Performance Check – CAC Detection (Zero Wait DFS)**

C9136I-B supports Zero-Wait-DFS through Rolling CAC. Refer also to the Radio Theory of Operation.

#### Procedure

Brief summary of the steps:

1. Configure the EUT for current channel with downlink traffic (greater than 17% duty cycle) to the client
2. Send the pre-CAC command for the future channel
3. Start statistics test on future channel (without configuring the EUT to the future channel), while data is transmitting on the current channel. Use Bin 0 radar.
  - a. Monitor console communications for detection messages on the future channel
4. Run 30 trials
5. Record the results

The steps below define the procedure to determine the minimum percentage of detection when a radar burst with a level equal to the DFS Detection Threshold + 1dB (-62dBm) is generated on the Operating Channel of the U-NII device. The radar level was increased by the amount of the antenna gain, resulting in a level of -60dBm.

A U-NII device operating as a Client Device will associate with the UUT (Master). Send traffic from the Master Device to the Client Device on the selected Channel for the entire period of the test.

The Radar Waveform generator sends the individual waveform for radar type 0 at -60dBm. Statistical data will be gathered to determine the ability of the device to detect the radar test waveforms. The device can utilize a test mode to demonstrate when detection occurs to prevent the need to reset the device between trial runs.

The percentage of successful detection is calculated by:

$$\frac{\text{TotalWaveformDetections}}{\text{TotalWaveformTrials}} \times 100 = \text{Probability of Detection Radar Waveform}$$

The Minimum number of trails, minimum percentage of successful detection and the average minimum percentage of successful detection are found in the *Radar Test Waveforms* section. The data represents the worst-case detection for 20 MHz and 80 MHz signal bandwidths.

**D1 Radio - Statistical Performance – Results Tables**

**Test Case 1 - USA Bin 0 – 20MHz – Current Channel 5260MHz/Future Channel 5320MHz**

Trial	Frequency	Pulses	PW (uS)	PRI (uS)	1=Detection 0=No Detection	Detection Percentage	Limit
1	5311.8	18	1	1428	0	93.3%	60.0%
2	5311.8	18	1	1428	1		
3	5311.8	18	1	1428	1		
4	5311.8	18	1	1428	1		
5	5314	18	1	1428	1		
6	5314	18	1	1428	1		
7	5314	18	1	1428	1		
8	5316	18	1	1428	1		
9	5316	18	1	1428	1		
10	5316	18	1	1428	1		
11	5318	18	1	1428	1		
12	5318	18	1	1428	1		
13	5318	18	1	1428	1		
14	5318	18	1	1428	1		
15	5320	18	1	1428	1		
16	5320	18	1	1428	1		
17	5320	18	1	1428	1		
18	5322	18	1	1428	0		
19	5322	18	1	1428	1		
20	5322	18	1	1428	1		
21	5324	18	1	1428	1		
22	5324	18	1	1428	1		
23	5324	18	1	1428	1		
24	5324	18	1	1428	1		
25	5326	18	1	1428	1		
26	5326	18	1	1428	1		
27	5326	18	1	1428	1		
28	5328.2	18	1	1428	1		
29	5328.2	18	1	1428	1		
30	5328.2	18	1	1428	1		

**Test Case 2 - USA Bin 0 – 20MHz – Current Channel 5320MHz/Future Channel 5260MHz**

Trial	Frequency	Pulses	PW (uS)	PRI (uS)	1=Detection 0=No Detection	Detection Percentage	Limit
1	5251.8	18	1	1428	1	76.7%	60.0%
2	5251.8	18	1	1428	1		
3	5251.8	18	1	1428	0		
4	5251.8	18	1	1428	0		
5	5254	18	1	1428	0		
6	5254	18	1	1428	0		
7	5254	18	1	1428	0		
8	5256	18	1	1428	0		
9	5256	18	1	1428	0		
10	5256	18	1	1428	1		
11	5258	18	1	1428	1		
12	5258	18	1	1428	1		
13	5258	18	1	1428	1		
14	5258	18	1	1428	1		
15	5260	18	1	1428	1		
16	5260	18	1	1428	1		
17	5260	18	1	1428	1		
18	5262	18	1	1428	1		
19	5262	18	1	1428	1		
20	5262	18	1	1428	1		
21	5264	18	1	1428	1		
22	5264	18	1	1428	1		
23	5264	18	1	1428	1		
24	5264	18	1	1428	1		
25	5266	18	1	1428	1		
26	5266	18	1	1428	1		
27	5266	18	1	1428	1		
28	5268.2	18	1	1428	1		
29	5268.2	18	1	1428	1		
30	5268.2	18	1	1428	1		

**Test Case 3 - USA Bin 0 – 20MHz – Current Channel 5500MHz/Future Channel 5700MHz**

Trial	Frequency	Pulses	PW (uS)	PRI (uS)	1=Detection 0=No Detection	Detection Percentage	Limit
1	5691.8	18	1	1428	1	96.7%	60.0%
2	5691.8	18	1	1428	1		
3	5691.8	18	1	1428	1		
4	5691.8	18	1	1428	1		
5	5694	18	1	1428	1		
6	5694	18	1	1428	1		
7	5694	18	1	1428	1		
8	5696	18	1	1428	1		
9	5696	18	1	1428	0		
10	5696	18	1	1428	1		
11	5698	18	1	1428	1		
12	5698	18	1	1428	1		
13	5698	18	1	1428	1		
14	5698	18	1	1428	1		
15	5700	18	1	1428	1		
16	5700	18	1	1428	1		
17	5700	18	1	1428	1		
18	5702	18	1	1428	1		
19	5702	18	1	1428	1		
20	5702	18	1	1428	1		
21	5704	18	1	1428	1		
22	5704	18	1	1428	1		
23	5704	18	1	1428	1		
24	5704	18	1	1428	1		
25	5706	18	1	1428	1		
26	5706	18	1	1428	1		
27	5706	18	1	1428	1		
28	5708.2	18	1	1428	1		
29	5708.2	18	1	1428	1		
30	5708.2	18	1	1428	1		

**Test Case 4 - USA Bin 0 – 20MHz – Current Channel 5700MHz/Future Channel 5500MHz**

Trial	Frequency	Pulses	PW (uS)	PRI (uS)	1=Detection 0=No Detection	Detection Percentage	Limit
1	5491.8	18	1	1428	1	93.3%	60.0%
2	5491.8	18	1	1428	1		
3	5491.8	18	1	1428	1		
4	5491.8	18	1	1428	1		
5	5494	18	1	1428	1		
6	5494	18	1	1428	1		
7	5494	18	1	1428	1		
8	5496	18	1	1428	1		
9	5496	18	1	1428	1		
10	5496	18	1	1428	1		
11	5498	18	1	1428	1		
12	5498	18	1	1428	1		
13	5498	18	1	1428	1		
14	5498	18	1	1428	1		
15	5500	18	1	1428	1		
16	5500	18	1	1428	1		
17	5500	18	1	1428	1		
18	5502	18	1	1428	1		
19	5502	18	1	1428	0		
20	5502	18	1	1428	1		
21	5504	18	1	1428	1		
22	5504	18	1	1428	0		
23	5504	18	1	1428	1		
24	5504	18	1	1428	1		
25	5506	18	1	1428	1		
26	5506	18	1	1428	1		
27	5506	18	1	1428	1		
28	5508.2	18	1	1428	1		
29	5508.2	18	1	1428	1		
30	5508.2	18	1	1428	1		



**Test Case 5 - USA Bin 0 – 80MHz – Current Channel 5690MHz/Future Channel 5290MHz**

Trial	Frequency	Pulses	PW (uS)	PRI (uS)	1=Detection 0=No Detection	Detection Percentage	Limit
1	5251.3	18	1	1428	0	80.0%	60.0%
2	5251.3	18	1	1428	1		
3	5256	18	1	1428	1		
4	5256	18	1	1428	1		
5	5262	18	1	1428	1		
6	5262	18	1	1428	1		
7	5268	18	1	1428	1		
8	5268	18	1	1428	0		
9	5274	18	1	1428	0		
10	5274	18	1	1428	1		
11	5280	18	1	1428	1		
12	5280	18	1	1428	1		
13	5286	18	1	1428	1		
14	5286	18	1	1428	1		
15	5290	18	1	1428	0		
16	5290	18	1	1428	0		
17	5294	18	1	1428	1		
18	5294	18	1	1428	1		
19	5300	18	1	1428	1		
20	5300	18	1	1428	0		
21	5306	18	1	1428	1		
22	5306	18	1	1428	1		
23	5312	18	1	1428	1		
24	5312	18	1	1428	1		
25	5318	18	1	1428	1		
26	5318	18	1	1428	1		
27	5324	18	1	1428	1		
28	5324	18	1	1428	1		
29	5328.7	18	1	1428	1		
30	5328.7	18	1	1428	1		

**Test Case 6 - USA Bin 0 – 80MHz – Current Channel 5530MHz/Future Channel 5690MHz**

Trial	Frequency	Pulses	PW (uS)	PRI (uS)	1=Detection 0=No Detection	Detection Percentage	Limit
1	5651.2	18	1	1428	1	73.3%	60.0%
2	5651.2	18	1	1428	0		
3	5656	18	1	1428	1		
4	5656	18	1	1428	1		
5	5662	18	1	1428	1		
6	5662	18	1	1428	1		
7	5668	18	1	1428	0		
8	5668	18	1	1428	1		
9	5674	18	1	1428	1		
10	5674	18	1	1428	1		
11	5680	18	1	1428	1		
12	5680	18	1	1428	0		
13	5686	18	1	1428	1		
14	5686	18	1	1428	1		
15	5690	18	1	1428	1		
16	5690	18	1	1428	1		
17	5694	18	1	1428	1		
18	5694	18	1	1428	0		
19	5700	18	1	1428	1		
20	5700	18	1	1428	1		
21	5706	18	1	1428	1		
22	5706	18	1	1428	1		
23	5712	18	1	1428	0		
24	5712	18	1	1428	1		
25	5718	18	1	1428	0		
26	5718	18	1	1428	0		
27	5724	18	1	1428	0		
28	5724	18	1	1428	1		
29	5728.8	18	1	1428	1		
30	5728.8	18	1	1428	1		

**Test Case 7 - USA Bin 0 – 80MHz – Current Channel 5690MHz/Future Channel 5530MHz**

Trial	Frequency	Pulses	PW (uS)	PRI (uS)	1=Detection 0=No Detection	Detection Percentage	Limit
1	5491.2	18	1	1428	1	83.3%	60.0%
2	5491.2	18	1	1428	0		
3	5496	18	1	1428	0		
4	5496	18	1	1428	1		
5	5502	18	1	1428	1		
6	5502	18	1	1428	0		
7	5508	18	1	1428	1		
8	5508	18	1	1428	1		
9	5514	18	1	1428	1		
10	5514	18	1	1428	1		
11	5520	18	1	1428	1		
12	5520	18	1	1428	1		
13	5526	18	1	1428	1		
14	5526	18	1	1428	1		
15	5530	18	1	1428	1		
16	5530	18	1	1428	1		
17	5534	18	1	1428	1		
18	5534	18	1	1428	1		
19	5540	18	1	1428	1		
20	5540	18	1	1428	1		
21	5546	18	1	1428	1		
22	5546	18	1	1428	1		
23	5552	18	1	1428	1		
24	5552	18	1	1428	1		
25	5558	18	1	1428	1		
26	5558	18	1	1428	1		
27	5564	18	1	1428	0		
28	5564	18	1	1428	0		
29	5568.8	18	1	1428	1		
30	5568.8	18	1	1428	1		

**D1 Radio - Statistical Performance – Plots**

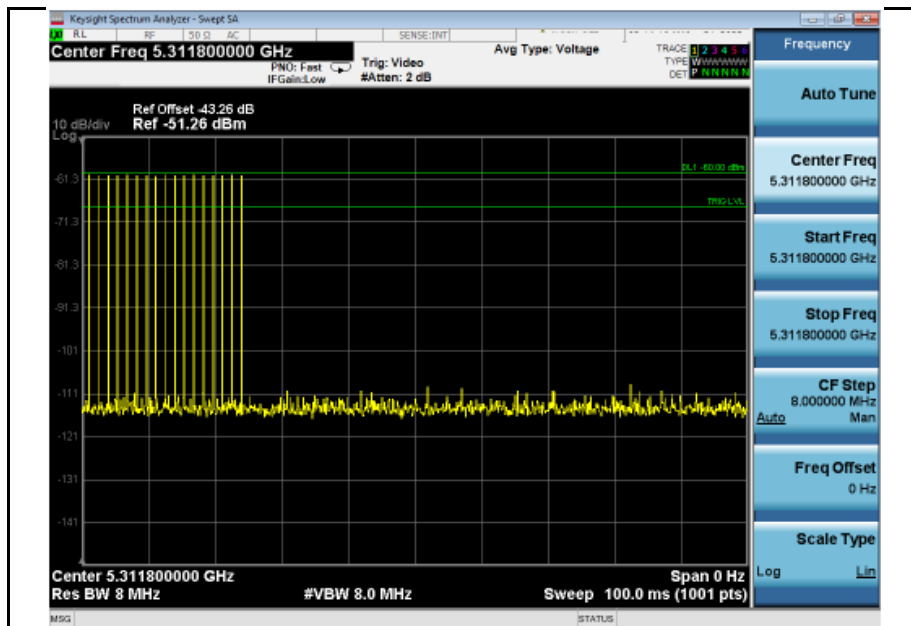

**Test Case 1 - USA Bin 0 – 20MHz  
 Current Channel 5260MHz / Future Channel 5320MHz**

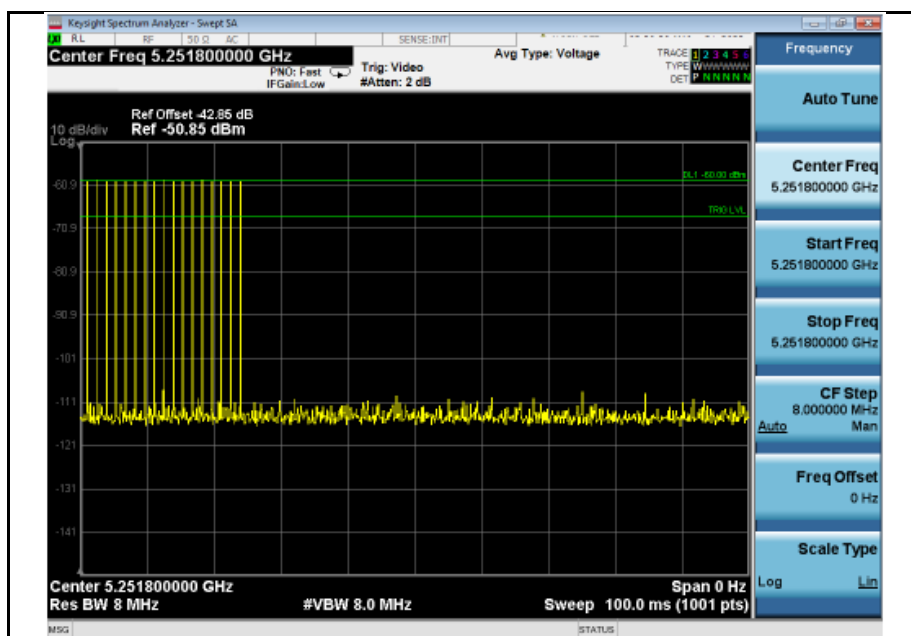

**Test Case 2 - USA Bin 0 – 20MHz  
 Current Channel 5320MHz / Future Channel 5260MHz**

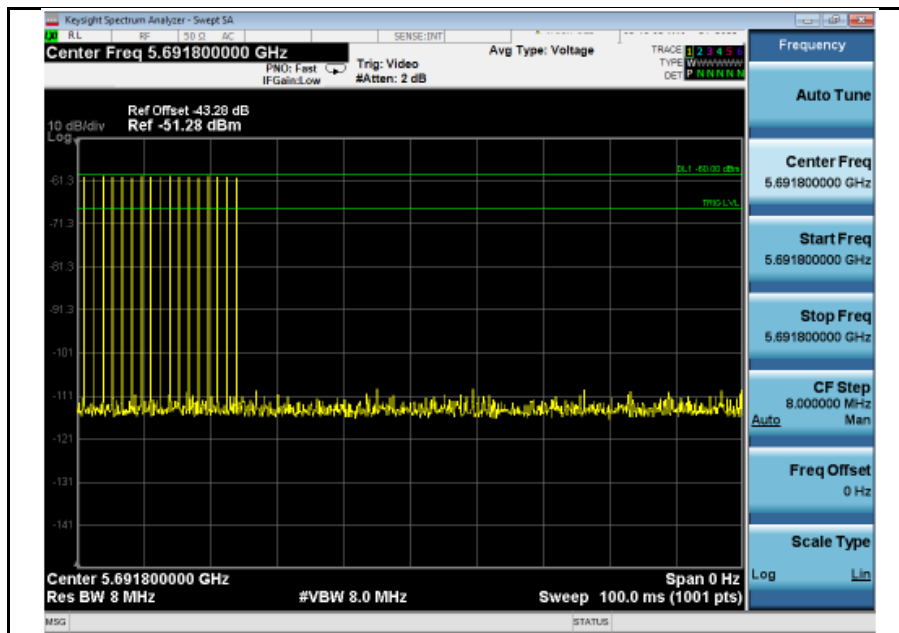

**Test Case 3 - USA Bin 0 – 20MHz**  
**Current Channel 5500MHz / Future Channel 5700MHz**

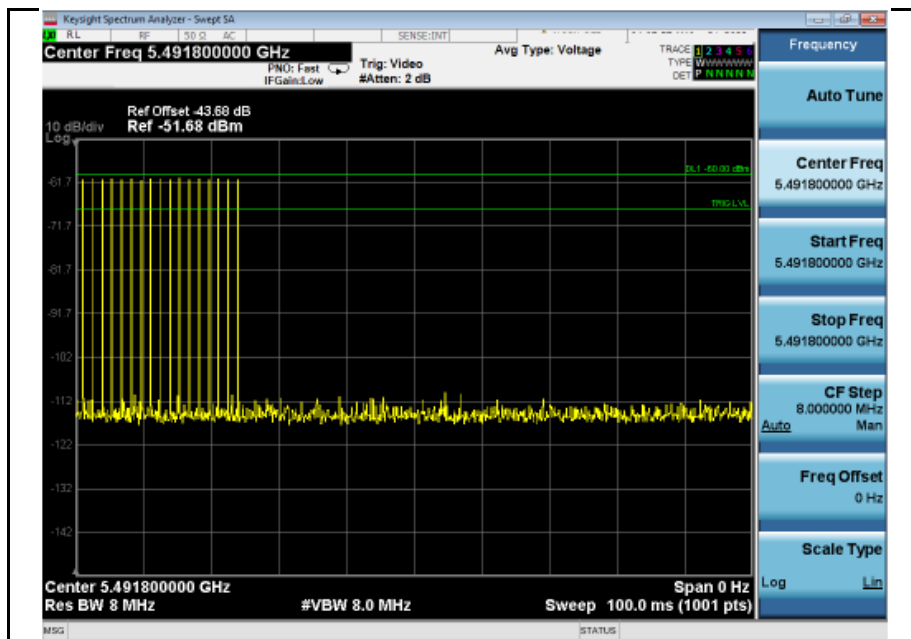

**Test Case 4 - USA Bin 0 – 20MHz**  
**Current Channel 5700MHz / Future Channel 5500MHz**

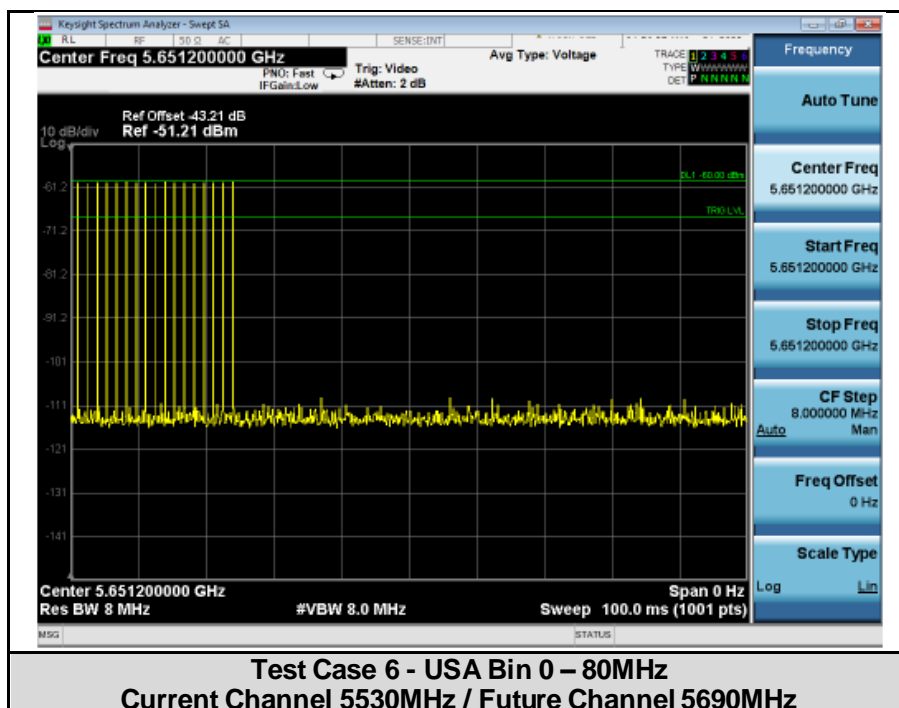
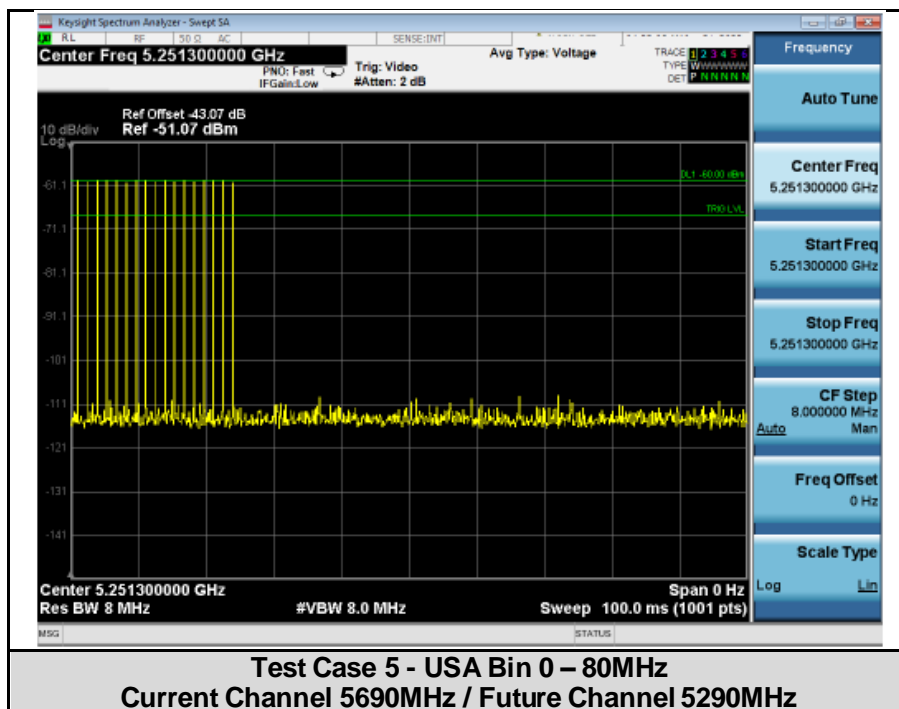

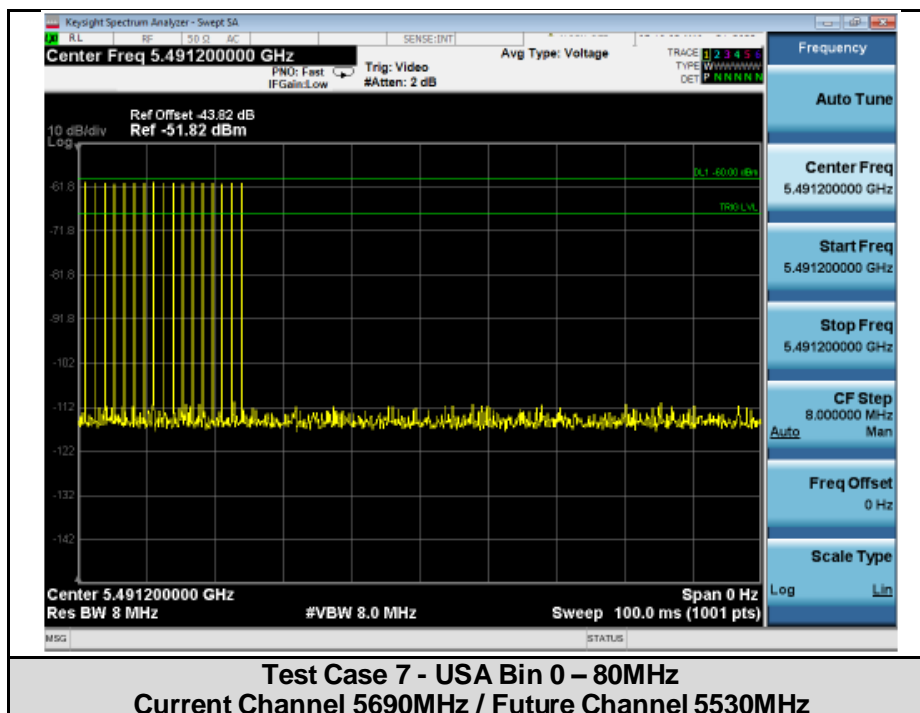

**D2 Radio - Statistical Performance – Results Tables**

**Test Case 1 - USA Bin 0 – 20MHz – Current Channel 5260MHz/Future Channel 5320MHz**

Trial	Frequency	Pulses	PW (uS)	PRI (uS)	1=Detection 0=No Detection	Detection Percentage	Limit
1	5311.6	18	1	1428	1	100.0%	60.0%
2	5311.6	18	1	1428	1		
3	5311.6	18	1	1428	1		
4	5311.6	18	1	1428	1		
5	5314	18	1	1428	1		
6	5314	18	1	1428	1		
7	5314	18	1	1428	1		
8	5316	18	1	1428	1		
9	5316	18	1	1428	1		
10	5316	18	1	1428	1		
11	5318	18	1	1428	1		
12	5318	18	1	1428	1		
13	5318	18	1	1428	1		
14	5318	18	1	1428	1		
15	5320	18	1	1428	1		
16	5320	18	1	1428	1		
17	5320	18	1	1428	1		
18	5322	18	1	1428	1		
19	5322	18	1	1428	1		
20	5322	18	1	1428	1		
21	5324	18	1	1428	1		
22	5324	18	1	1428	1		
23	5324	18	1	1428	1		
24	5324	18	1	1428	1		
25	5326	18	1	1428	1		
26	5326	18	1	1428	1		
27	5326	18	1	1428	1		
28	5328.4	18	1	1428	1		
29	5328.4	18	1	1428	1		
30	5328.4	18	1	1428	1		



**Test Case 2 - USA Bin 0 – 20MHz – Current Channel 5320MHz/Future Channel 5260MHz**

Trial	Frequency	Pulses	PW (uS)	PRI (uS)	1=Detection 0=No Detection	Detection Percentage	Limit
1	5251.6	18	1	1428	1	93.3%	60.0%
2	5251.6	18	1	1428	1		
3	5251.6	18	1	1428	1		
4	5251.6	18	1	1428	1		
5	5254	18	1	1428	1		
6	5254	18	1	1428	1		
7	5254	18	1	1428	1		
8	5256	18	1	1428	1		
9	5256	18	1	1428	1		
10	5256	18	1	1428	1		
11	5258	18	1	1428	0		
12	5258	18	1	1428	1		
13	5258	18	1	1428	1		
14	5258	18	1	1428	1		
15	5260	18	1	1428	1		
16	5260	18	1	1428	1		
17	5260	18	1	1428	1		
18	5262	18	1	1428	1		
19	5262	18	1	1428	1		
20	5262	18	1	1428	1		
21	5264	18	1	1428	1		
22	5264	18	1	1428	1		
23	5264	18	1	1428	1		
24	5264	18	1	1428	1		
25	5266	18	1	1428	1		
26	5266	18	1	1428	1		
27	5266	18	1	1428	1		
28	5268.4	18	1	1428	1		
29	5268.4	18	1	1428	1		
30	5268.4	18	1	1428	0		

**Test Case 3 - USA Bin 0 – 20MHz – Current Channel 5500MHz/Future Channel 5700MHz**

Trial	Frequency	Pulses	PW (uS)	PRI (uS)	1=Detection 0=No Detection	Detection Percentage	Limit
1	5691.6	18	1	1428	1	90.0%	60.0%
2	5691.6	18	1	1428	0		
3	5691.6	18	1	1428	1		
4	5691.6	18	1	1428	1		
5	5694	18	1	1428	1		
6	5694	18	1	1428	1		
7	5694	18	1	1428	1		
8	5696	18	1	1428	1		
9	5696	18	1	1428	1		
10	5696	18	1	1428	1		
11	5698	18	1	1428	1		
12	5698	18	1	1428	1		
13	5698	18	1	1428	1		
14	5698	18	1	1428	1		
15	5700	18	1	1428	0		
16	5700	18	1	1428	1		
17	5700	18	1	1428	1		
18	5702	18	1	1428	1		
19	5702	18	1	1428	1		
20	5702	18	1	1428	1		
21	5704	18	1	1428	1		
22	5704	18	1	1428	1		
23	5704	18	1	1428	1		
24	5704	18	1	1428	1		
25	5706	18	1	1428	1		
26	5706	18	1	1428	1		
27	5706	18	1	1428	0		
28	5708.4	18	1	1428	1		
29	5708.4	18	1	1428	1		
30	5708.4	18	1	1428	1		

**Test Case 4 - USA Bin 0 – 20MHz – Current Channel 5700MHz/Future Channel 5500MHz**

Trial	Frequency	Pulses	PW (uS)	PRI (uS)	1=Detection 0=No Detection	Detection Percentage	Limit
1	5491.6	18	1	1428	1	93.3%	60.0%
2	5491.6	18	1	1428	1		
3	5491.6	18	1	1428	1		
4	5491.6	18	1	1428	1		
5	5494	18	1	1428	1		
6	5494	18	1	1428	1		
7	5494	18	1	1428	1		
8	5496	18	1	1428	1		
9	5496	18	1	1428	1		
10	5496	18	1	1428	1		
11	5498	18	1	1428	1		
12	5498	18	1	1428	1		
13	5498	18	1	1428	1		
14	5498	18	1	1428	1		
15	5500	18	1	1428	1		
16	5500	18	1	1428	1		
17	5500	18	1	1428	1		
18	5502	18	1	1428	1		
19	5502	18	1	1428	1		
20	5502	18	1	1428	1		
21	5504	18	1	1428	1		
22	5504	18	1	1428	0		
23	5504	18	1	1428	1		
24	5504	18	1	1428	1		
25	5506	18	1	1428	1		
26	5506	18	1	1428	0		
27	5506	18	1	1428	1		
28	5508.4	18	1	1428	1		
29	5508.4	18	1	1428	1		
30	5508.4	18	1	1428	1		

**Test Case 5 - USA Bin 0 – 80MHz – Current Channel 5690MHz/Future Channel 5290MHz**

Trial	Frequency	Pulses	PW (uS)	PRI (uS)	1=Detection 0=No Detection	Detection Percentage	Limit
1	5250.9	18	1	1428	1	90.0%	60.0%
2	5250.9	18	1	1428	1		
3	5256	18	1	1428	1		
4	5256	18	1	1428	1		
5	5262	18	1	1428	1		
6	5262	18	1	1428	1		
7	5268	18	1	1428	1		
8	5268	18	1	1428	1		
9	5274	18	1	1428	1		
10	5274	18	1	1428	1		
11	5280	18	1	1428	1		
12	5280	18	1	1428	1		
13	5286	18	1	1428	0		
14	5286	18	1	1428	1		
15	5290	18	1	1428	1		
16	5290	18	1	1428	1		
17	5294	18	1	1428	1		
18	5294	18	1	1428	1		
19	5300	18	1	1428	0		
20	5300	18	1	1428	0		
21	5306	18	1	1428	1		
22	5306	18	1	1428	1		
23	5312	18	1	1428	1		
24	5312	18	1	1428	1		
25	5318	18	1	1428	1		
26	5318	18	1	1428	1		
27	5324	18	1	1428	1		
28	5324	18	1	1428	1		
29	5329.1	18	1	1428	1		
30	5329.1	18	1	1428	1		

**Test Case 6 - USA Bin 0 – 80MHz – Current Channel 5530MHz/Future Channel 5690MHz**

Trial	Frequency	Pulses	PW (uS)	PRI (uS)	1=Detection 0=No Detection	Detection Percentage	Limit
1	5650.9	18	1	1428	1	73.3%	60.0%
2	5650.9	18	1	1428	1		
3	5656	18	1	1428	1		
4	5656	18	1	1428	1		
5	5662	18	1	1428	1		
6	5662	18	1	1428	1		
7	5668	18	1	1428	1		
8	5668	18	1	1428	1		
9	5674	18	1	1428	0		
10	5674	18	1	1428	0		
11	5680	18	1	1428	0		
12	5680	18	1	1428	1		
13	5686	18	1	1428	0		
14	5686	18	1	1428	1		
15	5690	18	1	1428	1		
16	5690	18	1	1428	1		
17	5694	18	1	1428	1		
18	5694	18	1	1428	1		
19	5700	18	1	1428	0		
20	5700	18	1	1428	1		
21	5706	18	1	1428	1		
22	5706	18	1	1428	1		
23	5712	18	1	1428	1		
24	5712	18	1	1428	0		
25	5718	18	1	1428	1		
26	5718	18	1	1428	1		
27	5724	18	1	1428	0		
28	5724	18	1	1428	1		
29	5729.1	18	1	1428	0		
30	5729.1	18	1	1428	1		

**Test Case 7 - USA Bin 0 – 80MHz – Current Channel 5690MHz/Future Channel 5530MHz**

Trial	Frequency	Pulses	PW (uS)	PRI (uS)	1=Detection 0=No Detection	Detection Percentage	Limit
1	5490.9	18	1	1428	1	90.0%	60.0%
2	5490.9	18	1	1428	1		
3	5496	18	1	1428	1		
4	5496	18	1	1428	1		
5	5502	18	1	1428	1		
6	5502	18	1	1428	1		
7	5508	18	1	1428	1		
8	5508	18	1	1428	0		
9	5514	18	1	1428	1		
10	5514	18	1	1428	1		
11	5520	18	1	1428	1		
12	5520	18	1	1428	1		
13	5526	18	1	1428	1		
14	5526	18	1	1428	1		
15	5530	18	1	1428	1		
16	5530	18	1	1428	1		
17	5534	18	1	1428	1		
18	5534	18	1	1428	1		
19	5540	18	1	1428	1		
20	5540	18	1	1428	0		
21	5546	18	1	1428	1		
22	5546	18	1	1428	1		
23	5552	18	1	1428	1		
24	5552	18	1	1428	1		
25	5558	18	1	1428	1		
26	5558	18	1	1428	1		
27	5564	18	1	1428	1		
28	5564	18	1	1428	1		
29	5569.1	18	1	1428	1		
30	5569.1	18	1	1428	0		

**D2 Radio - Statistical Performance – Plots**

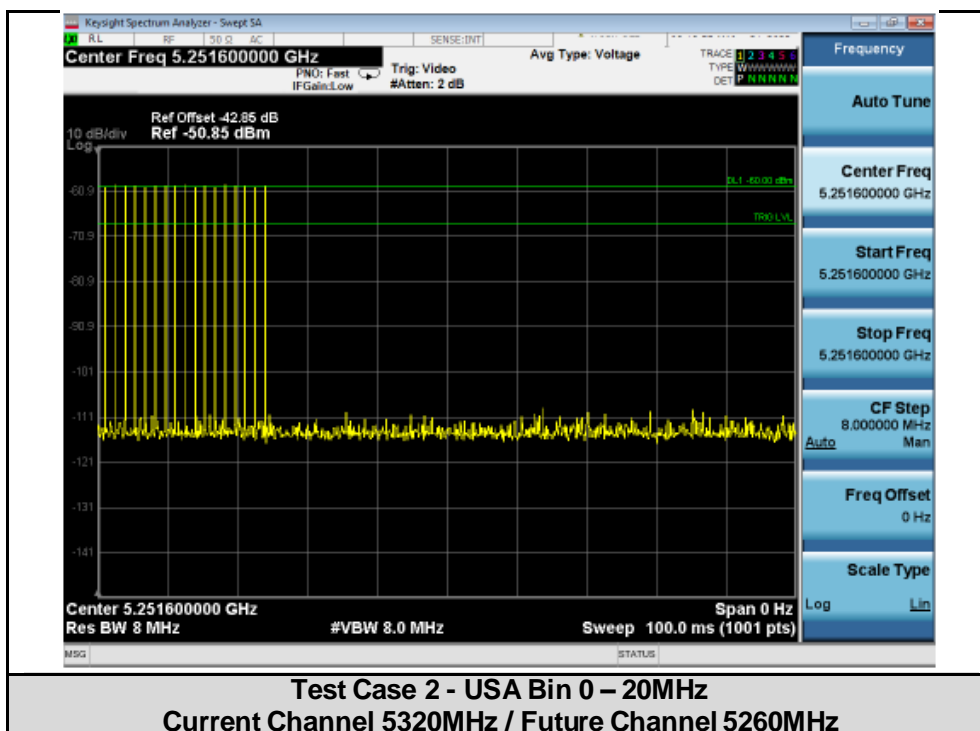
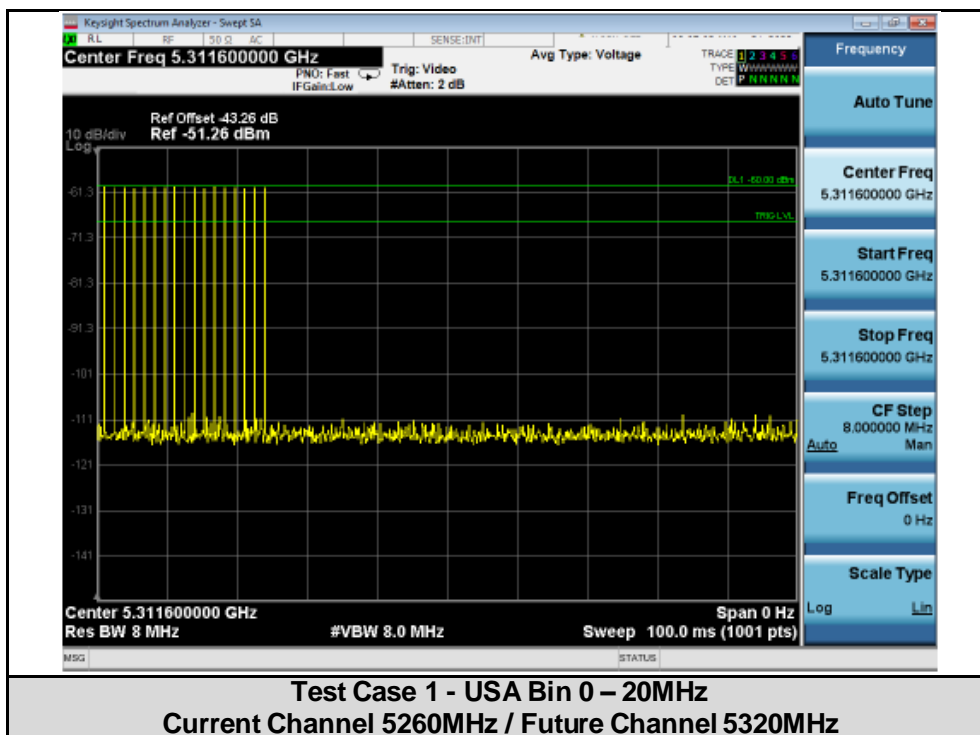

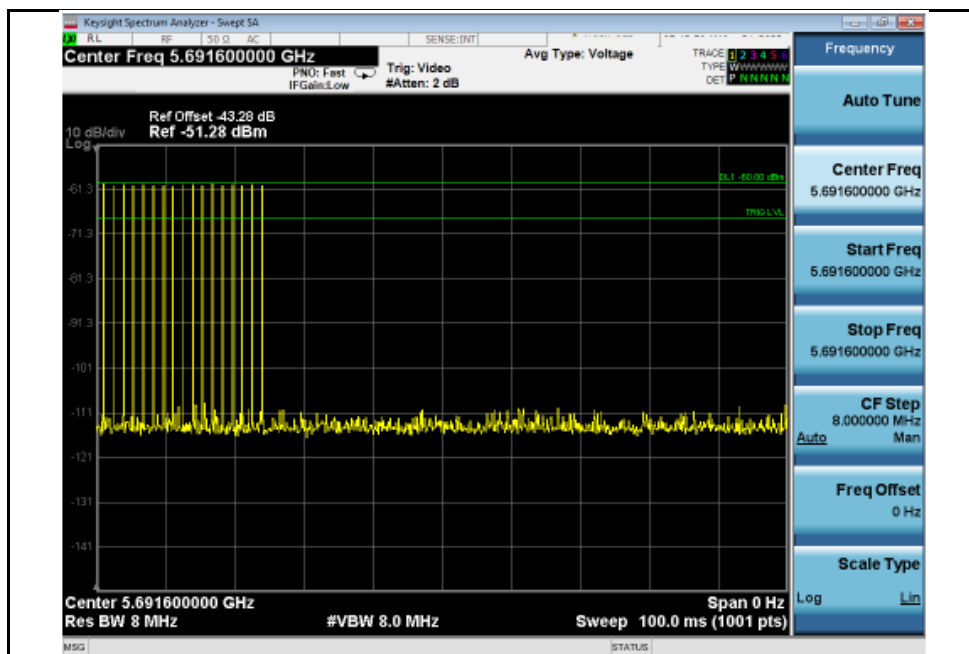

**Test Case 3 - USA Bin 0 – 20MHz  
Current Channel 5500MHz / Future Channel 5700MHz**

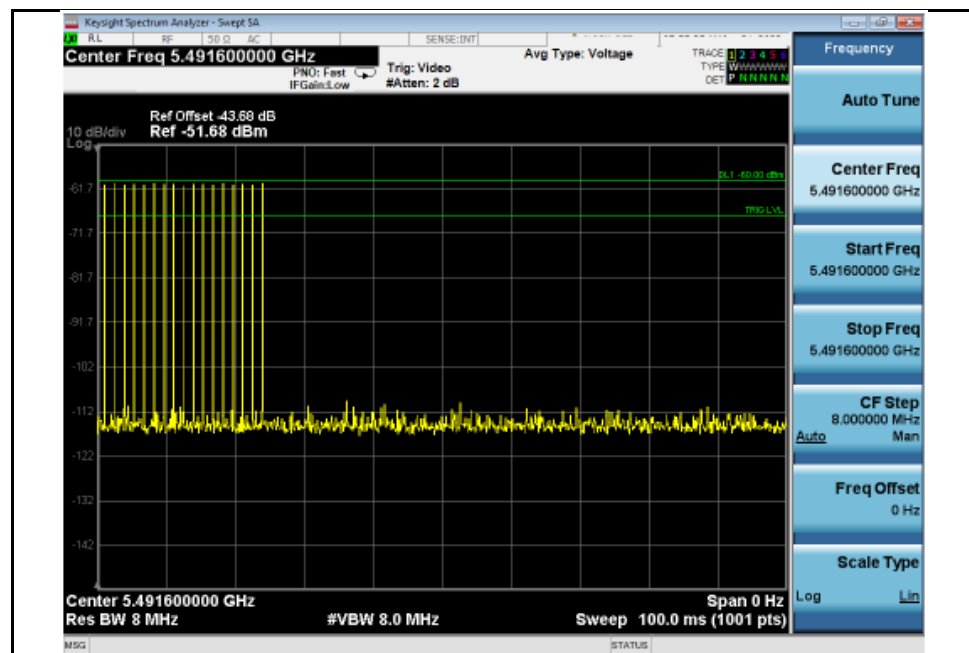

**Test Case 4 - USA Bin 0 – 20MHz  
Current Channel 5700MHz / Future Channel 5500MHz**



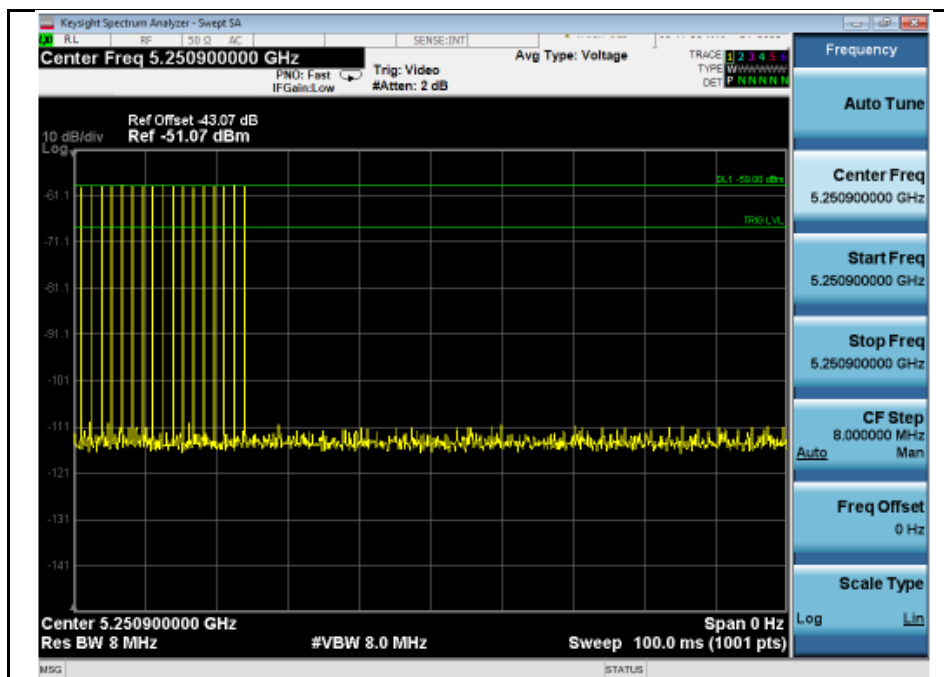

**Test Case 5 - USA Bin 0 – 80MHz  
Current Channel 5690MHz / Future Channel 5290MHz**

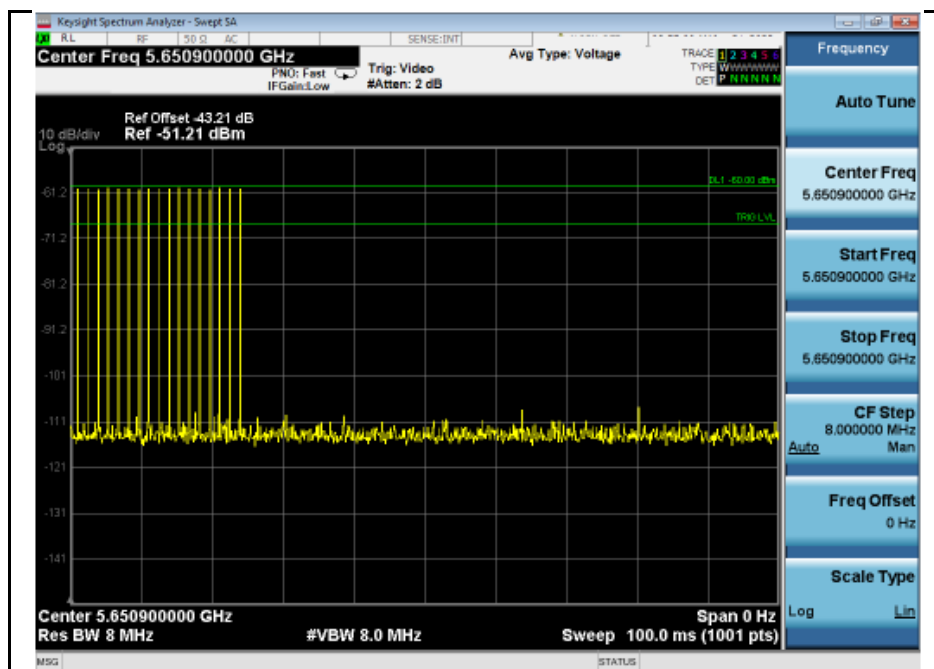

**Test Case 6 - USA Bin 0 – 80MHz  
Current Channel 5530MHz / Future Channel 5690MHz**

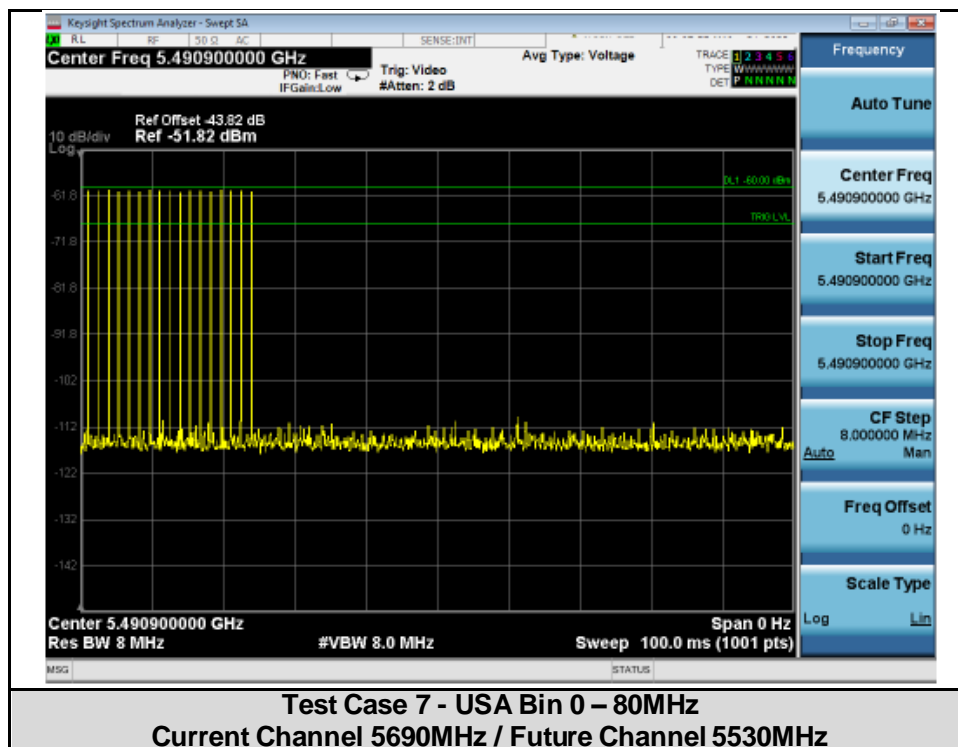

**Dual Radio - Statistical Performance – Results Tables**

**Test Case 1 - USA Bin 0 – 20MHz – Current Channel 5260MHz/Future Channel 5320MHz**

Trial	Frequency	Pulses	PW (uS)	PRI (uS)	1=Detection 0=No Detection	Detection Percentage	Limit
1	5311.7	18	1	1428	1	90.0%	60.0%
2	5311.7	18	1	1428	1		
3	5311.7	18	1	1428	1		
4	5311.7	18	1	1428	1		
5	5314	18	1	1428	1		
6	5314	18	1	1428	1		
7	5314	18	1	1428	1		
8	5316	18	1	1428	1		
9	5316	18	1	1428	0		
10	5316	18	1	1428	1		
11	5318	18	1	1428	1		
12	5318	18	1	1428	1		
13	5318	18	1	1428	1		
14	5318	18	1	1428	1		
15	5320	18	1	1428	1		
16	5320	18	1	1428	1		
17	5320	18	1	1428	1		
18	5322	18	1	1428	1		
19	5322	18	1	1428	1		
20	5322	18	1	1428	1		
21	5324	18	1	1428	1		
22	5324	18	1	1428	1		
23	5324	18	1	1428	1		
24	5324	18	1	1428	1		
25	5326	18	1	1428	1		
26	5326	18	1	1428	0		
27	5326	18	1	1428	0		
28	5328.3	18	1	1428	1		
29	5328.3	18	1	1428	1		
30	5328.3	18	1	1428	1		

**Test Case 2 - USA Bin 0 – 20MHz – Current Channel 5320MHz/Future Channel 5260MHz**

Trial	Frequency	Pulses	PW (uS)	PRI (uS)	1=Detection 0=No Detection	Detection Percentage	Limit
1	5251.7	18	1	1428	1	80.0%	60.0%
2	5251.7	18	1	1428	1		
3	5251.7	18	1	1428	0		
4	5251.7	18	1	1428	1		
5	5254	18	1	1428	1		
6	5254	18	1	1428	1		
7	5254	18	1	1428	1		
8	5256	18	1	1428	0		
9	5256	18	1	1428	1		
10	5256	18	1	1428	1		
11	5258	18	1	1428	1		
12	5258	18	1	1428	0		
13	5258	18	1	1428	0		
14	5258	18	1	1428	1		
15	5260	18	1	1428	1		
16	5260	18	1	1428	1		
17	5260	18	1	1428	1		
18	5262	18	1	1428	1		
19	5262	18	1	1428	1		
20	5262	18	1	1428	1		
21	5264	18	1	1428	1		
22	5264	18	1	1428	1		
23	5264	18	1	1428	1		
24	5264	18	1	1428	1		
25	5266	18	1	1428	0		
26	5266	18	1	1428	1		
27	5266	18	1	1428	1		
28	5268.3	18	1	1428	1		
29	5268.3	18	1	1428	0		
30	5268.3	18	1	1428	1		

**Test Case 3 - USA Bin 0 – 20MHz – Current Channel 5500MHz/Future Channel 5700MHz**

Trial	Frequency	Pulses	PW (uS)	PRI (uS)	1=Detection 0=No Detection	Detection Percentage	Limit
1	5691.7	18	1	1428	1	90.0%	60.0%
2	5691.7	18	1	1428	1		
3	5691.7	18	1	1428	1		
4	5691.7	18	1	1428	1		
5	5694	18	1	1428	1		
6	5694	18	1	1428	1		
7	5694	18	1	1428	1		
8	5696	18	1	1428	1		
9	5696	18	1	1428	1		
10	5696	18	1	1428	1		
11	5698	18	1	1428	1		
12	5698	18	1	1428	0		
13	5698	18	1	1428	1		
14	5698	18	1	1428	1		
15	5700	18	1	1428	1		
16	5700	18	1	1428	1		
17	5700	18	1	1428	1		
18	5702	18	1	1428	1		
19	5702	18	1	1428	1		
20	5702	18	1	1428	1		
21	5704	18	1	1428	1		
22	5704	18	1	1428	1		
23	5704	18	1	1428	0		
24	5704	18	1	1428	1		
25	5706	18	1	1428	1		
26	5706	18	1	1428	1		
27	5706	18	1	1428	1		
28	5708.3	18	1	1428	1		
29	5708.3	18	1	1428	0		
30	5708.3	18	1	1428	1		

**Test Case 4 - USA Bin 0 – 20MHz – Current Channel 5700MHz/Future Channel 5500MHz**

Trial	Frequency	Pulses	PW (uS)	PRI (uS)	1=Detection 0=No Detection	Detection Percentage	Limit
1	5491.7	18	1	1428	1	100.0%	60.0%
2	5491.7	18	1	1428	1		
3	5491.7	18	1	1428	1		
4	5491.7	18	1	1428	1		
5	5494	18	1	1428	1		
6	5494	18	1	1428	1		
7	5494	18	1	1428	1		
8	5496	18	1	1428	1		
9	5496	18	1	1428	1		
10	5496	18	1	1428	1		
11	5498	18	1	1428	1		
12	5498	18	1	1428	1		
13	5498	18	1	1428	1		
14	5498	18	1	1428	1		
15	5500	18	1	1428	1		
16	5500	18	1	1428	1		
17	5500	18	1	1428	1		
18	5502	18	1	1428	1		
19	5502	18	1	1428	1		
20	5502	18	1	1428	1		
21	5504	18	1	1428	1		
22	5504	18	1	1428	1		
23	5504	18	1	1428	1		
24	5504	18	1	1428	1		
25	5506	18	1	1428	1		
26	5506	18	1	1428	1		
27	5506	18	1	1428	1		
28	5508.3	18	1	1428	1		
29	5508.3	18	1	1428	1		
30	5508.3	18	1	1428	1		

**Test Case 5 - USA Bin 0 – 80MHz – Current Channel 5690MHz/Future Channel 5290MHz**

Trial	Frequency	Pulses	PW (uS)	PRI (uS)	1=Detection 0=No Detection	Detection Percentage	Limit
1	5251.4	18	1	1428	1	90.0%	60.0%
2	5251.4	18	1	1428	1		
3	5256	18	1	1428	1		
4	5256	18	1	1428	1		
5	5262	18	1	1428	1		
6	5262	18	1	1428	1		
7	5268	18	1	1428	1		
8	5268	18	1	1428	1		
9	5274	18	1	1428	1		
10	5274	18	1	1428	0		
11	5280	18	1	1428	1		
12	5280	18	1	1428	0		
13	5286	18	1	1428	1		
14	5286	18	1	1428	1		
15	5290	18	1	1428	1		
16	5290	18	1	1428	1		
17	5294	18	1	1428	1		
18	5294	18	1	1428	1		
19	5300	18	1	1428	1		
20	5300	18	1	1428	1		
21	5306	18	1	1428	1		
22	5306	18	1	1428	1		
23	5312	18	1	1428	1		
24	5312	18	1	1428	1		
25	5318	18	1	1428	1		
26	5318	18	1	1428	0		
27	5324	18	1	1428	1		
28	5324	18	1	1428	1		
29	5328.6	18	1	1428	1		
30	5328.6	18	1	1428	1		

**Test Case 6 - USA Bin 0 – 80MHz – Current Channel 5530MHz/Future Channel 5690MHz**

Trial	Frequency	Pulses	PW (uS)	PRI (uS)	1=Detection 0=No Detection	Detection Percentage	Limit
1	5651	18	1	1428	1	83.3%	60.0%
2	5651	18	1	1428	0		
3	5656	18	1	1428	1		
4	5656	18	1	1428	1		
5	5662	18	1	1428	1		
6	5662	18	1	1428	1		
7	5668	18	1	1428	1		
8	5668	18	1	1428	1		
9	5674	18	1	1428	1		
10	5674	18	1	1428	1		
11	5680	18	1	1428	1		
12	5680	18	1	1428	1		
13	5686	18	1	1428	1		
14	5686	18	1	1428	1		
15	5690	18	1	1428	0		
16	5690	18	1	1428	1		
17	5694	18	1	1428	1		
18	5694	18	1	1428	1		
19	5700	18	1	1428	1		
20	5700	18	1	1428	1		
21	5706	18	1	1428	1		
22	5706	18	1	1428	1		
23	5712	18	1	1428	1		
24	5712	18	1	1428	1		
25	5718	18	1	1428	1		
26	5718	18	1	1428	1		
27	5724	18	1	1428	0		
28	5724	18	1	1428	0		
29	5729	18	1	1428	0		
30	5729	18	1	1428	1		



**Test Case 7 - USA Bin 0 – 80MHz – Current Channel 5690MHz/Future Channel 5530MHz**

Trial	Frequency	Pulses	PW (uS)	PRI (uS)	1=Detection 0=No Detection	Detection Percentage	Limit
1	5491	18	1	1428	1	80.0%	60.0%
2	5491	18	1	1428	0		
3	5496	18	1	1428	1		
4	5496	18	1	1428	1		
5	5502	18	1	1428	1		
6	5502	18	1	1428	1		
7	5508	18	1	1428	0		
8	5508	18	1	1428	1		
9	5514	18	1	1428	1		
10	5514	18	1	1428	1		
11	5520	18	1	1428	1		
12	5520	18	1	1428	1		
13	5526	18	1	1428	1		
14	5526	18	1	1428	0		
15	5530	18	1	1428	0		
16	5530	18	1	1428	1		
17	5534	18	1	1428	1		
18	5534	18	1	1428	1		
19	5540	18	1	1428	1		
20	5540	18	1	1428	1		
21	5546	18	1	1428	0		
22	5546	18	1	1428	1		
23	5552	18	1	1428	1		
24	5552	18	1	1428	1		
25	5558	18	1	1428	1		
26	5558	18	1	1428	0		
27	5564	18	1	1428	1		
28	5564	18	1	1428	1		
29	5569	18	1	1428	1		
30	5569	18	1	1428	1		

**Dual Radio - Statistical Performance – Plots**

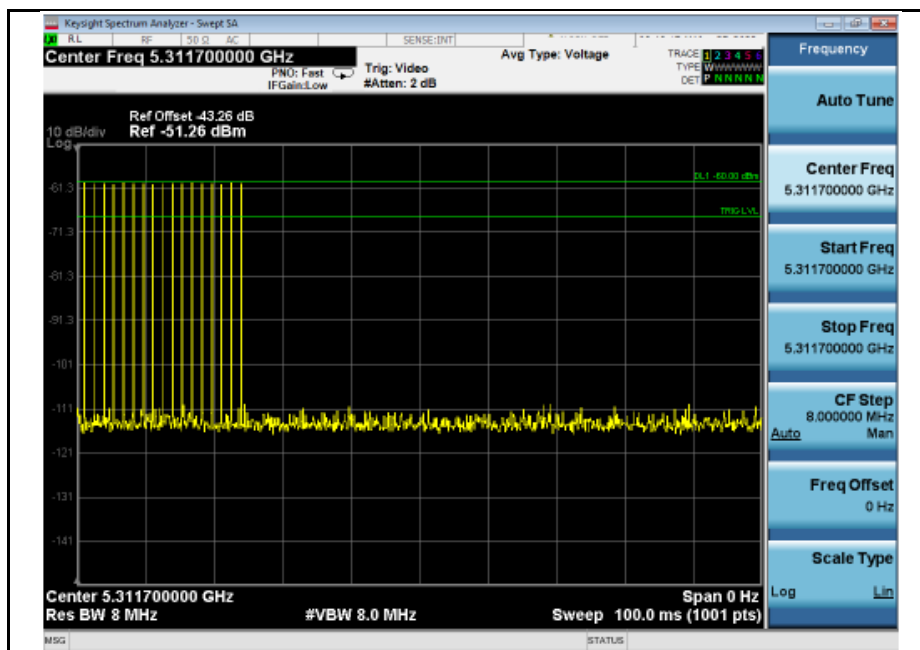

**Test Case 1 - USA Bin 0 – 20MHz  
 Current Channel 5260MHz / Future Channel 5320MHz**

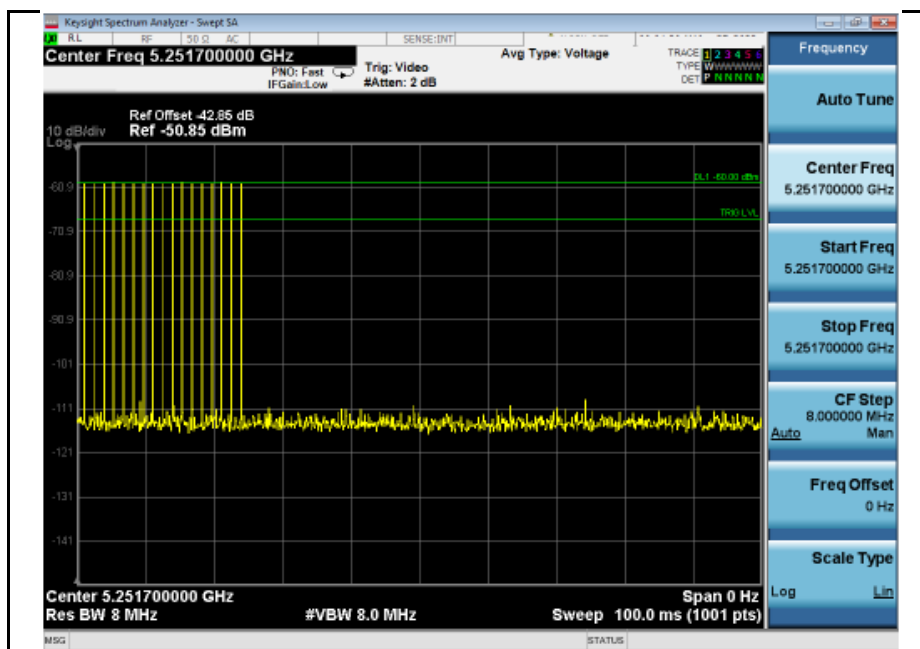

**Test Case 2 - USA Bin 0 – 20MHz  
 Current Channel 5320MHz / Future Channel 5260MHz**

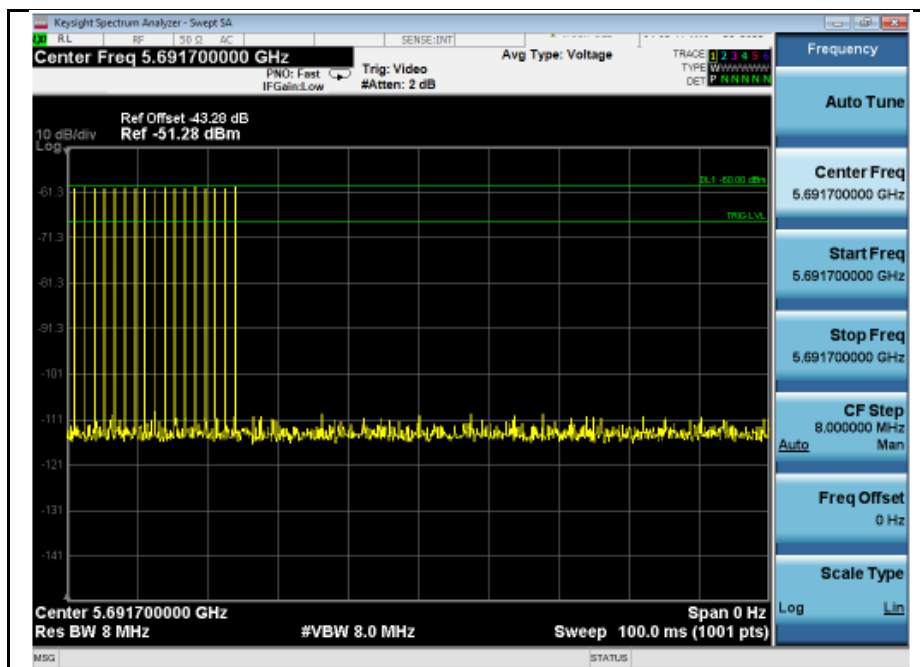

**Test Case 3 - USA Bin 0 – 20MHz  
Current Channel 5500MHz / Future Channel 5700MHz**

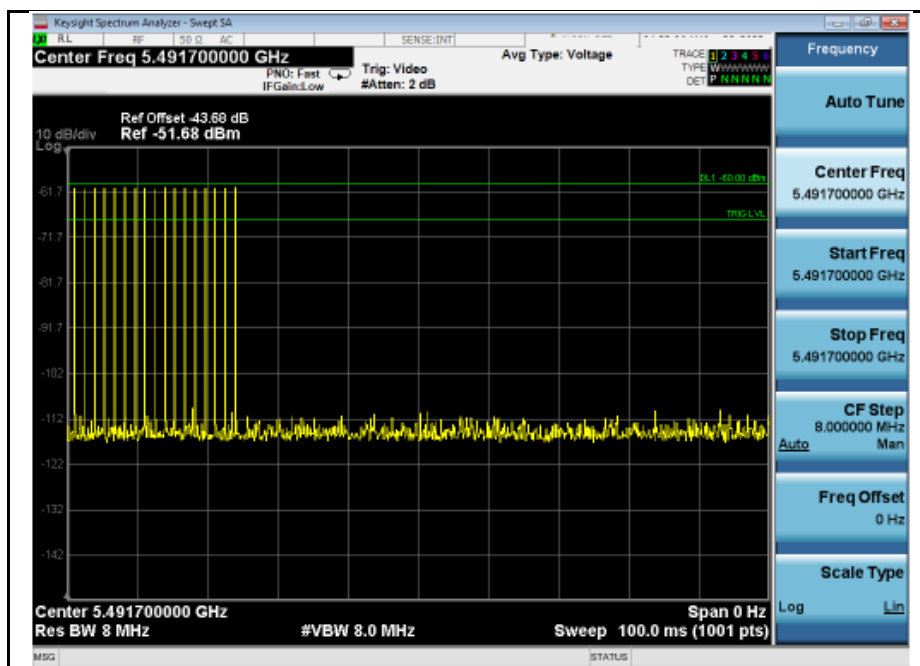

**Test Case 4 - USA Bin 0 – 20MHz  
Current Channel 5700MHz / Future Channel 5500MHz**

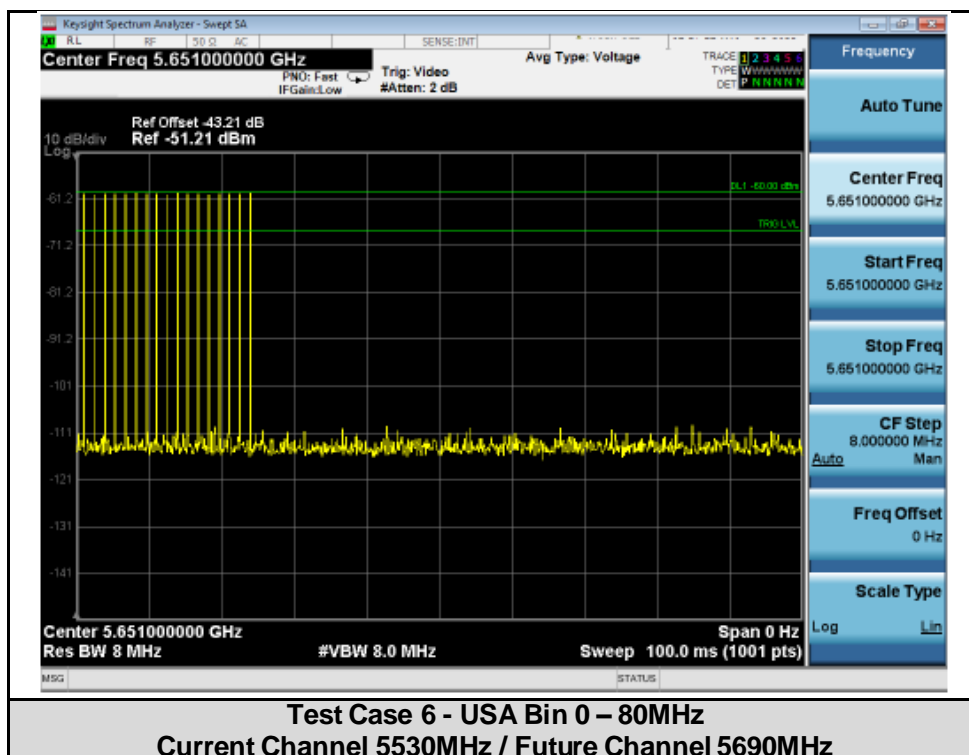
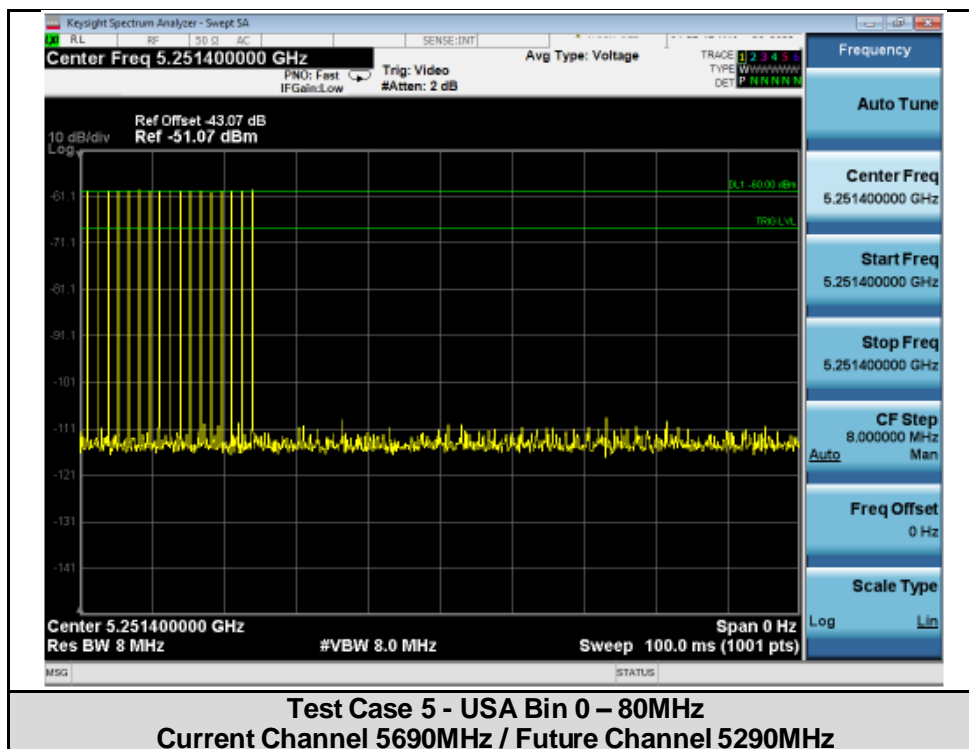

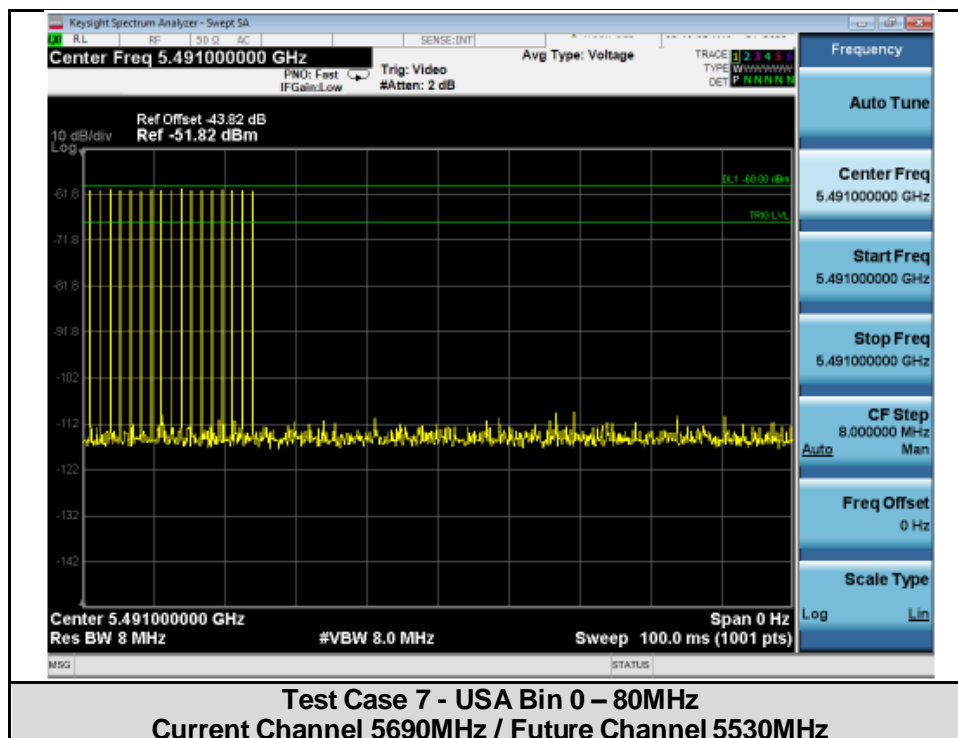

**Traffic Plots**

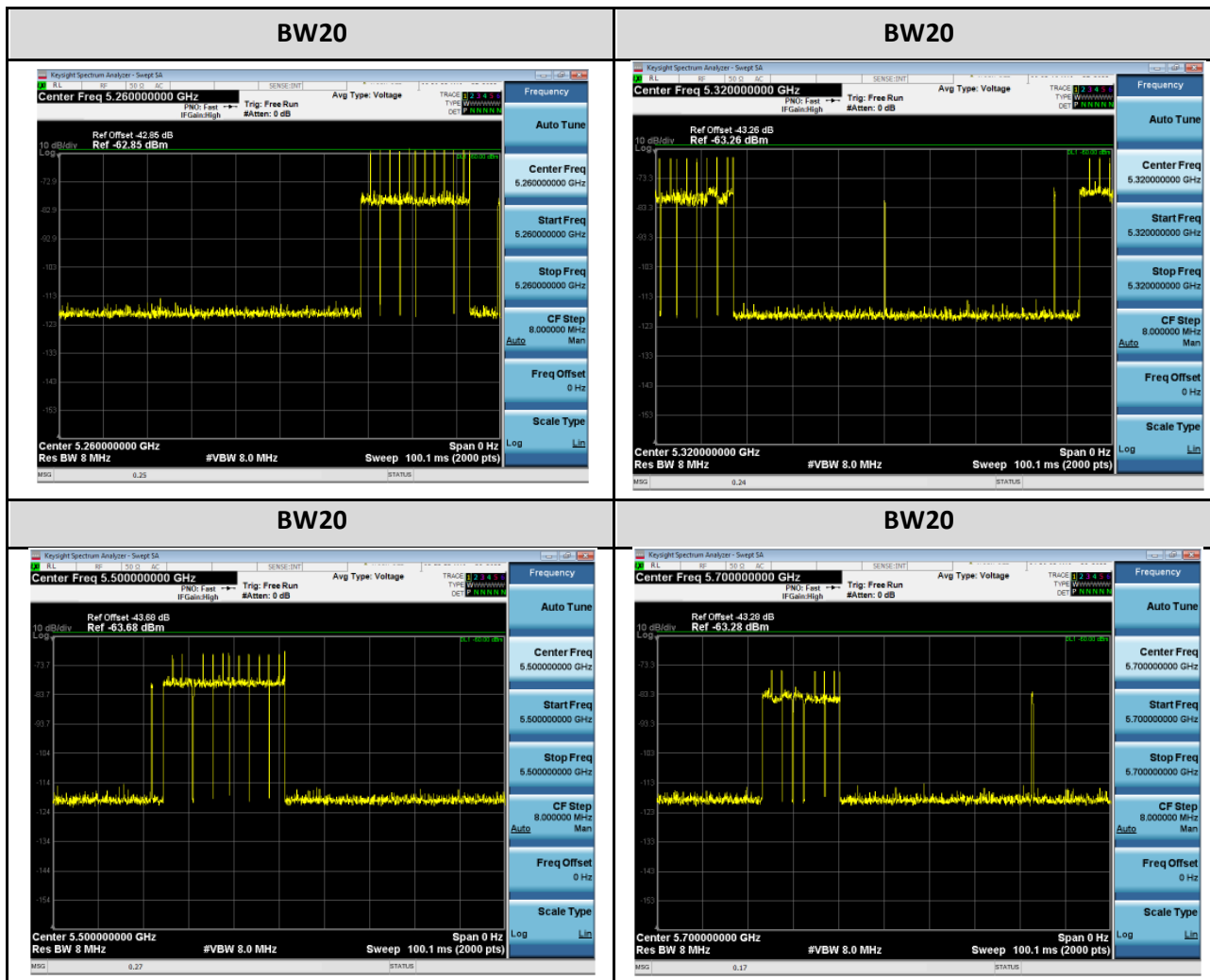

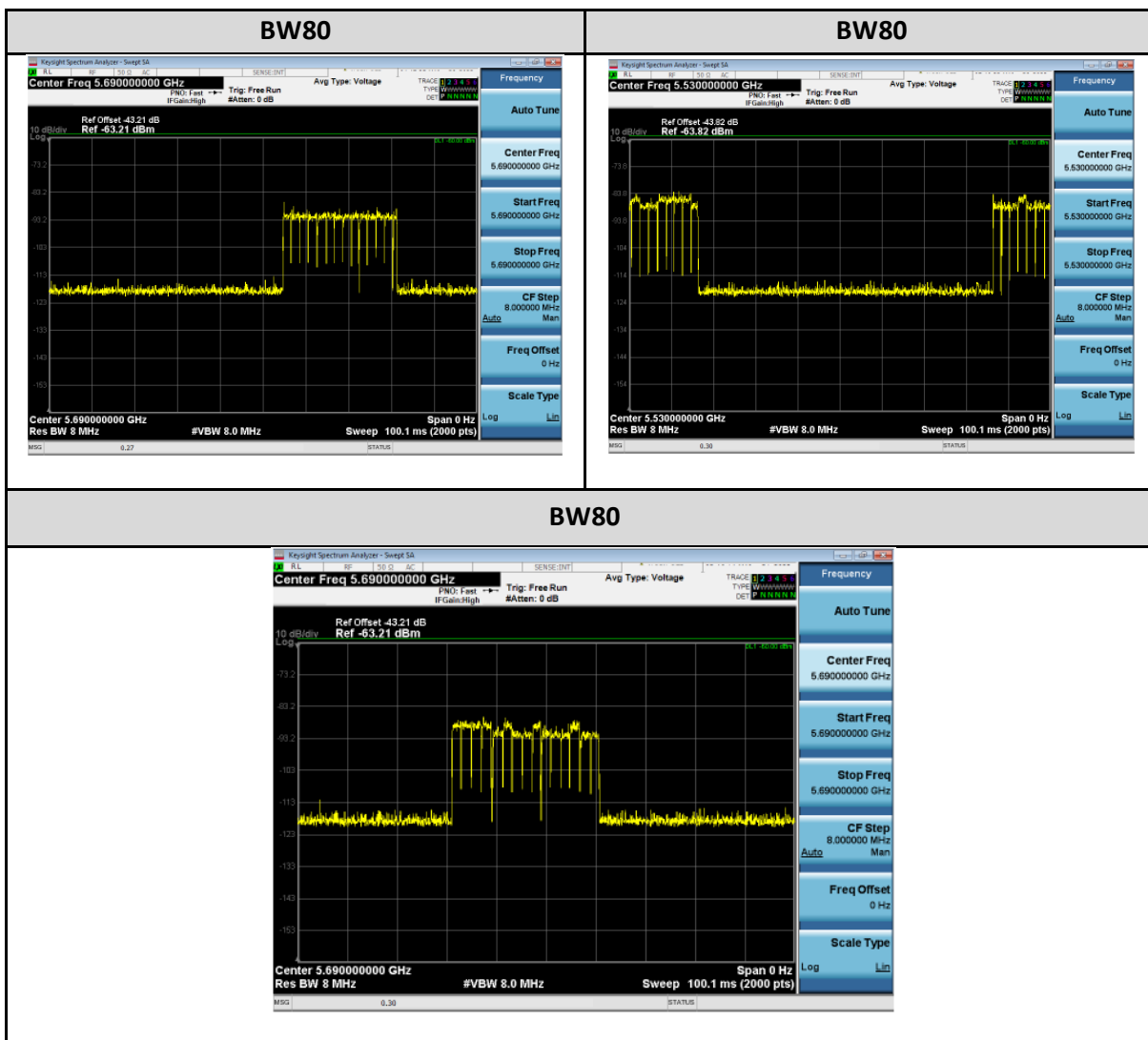

**Appendix C: List of Test Equipment Used to perform the test**

Equip#	Manufacturer/ Model	Description	Last Cal	Next Cal
42003	MINI-CIRCUITS/ BW-S30W2 +	30dB SMA Attenuator	24-Mar-22	24-Mar-23
42625	PASTERNAK/ PE6072	SMA 50 ohm termination	18-Mar-22	18-Mar-23
42628	PASTERNAK/ PE6072	SMA 50 ohm termination	01-Sep-22	01-Sep-23
42638	PASTERNAK/ PE6072	SMA 50 ohm termination	18-Mar-22	18-Mar-23
45066	MINI-CIRCUITS/ ZFSC-2-10G	SPLITTER, 2-10GHZ	11-Aug-22	11-Aug-23
49429	MINI-CIRCUITS/ ZFSC-2-10G	SPLITTER, 2-10GHZ	11-Aug-22	11-Aug-23
49514	NATIONAL INSTRUMENTS/ PXI-1042	PXI chassis	Cal Not Req'd	N/A
54303	Keysight (Agilent/HP)/N5182B	MXG X-Series RF Vector Signal Generator	23-Feb-22	23-Feb-23
54369	AEROFLEX/INMET/ 40AH2W-30	Attenuator 30dB 2.92mm 40GHz	28-Mar-22	28-Mar-23
54370	AEROFLEX/INMET/ 40AH2W-30	Attenuator 30dB 2.92mm 40GHz	28-Mar-22	28-Mar-23
54372	AEROFLEX/INMET/ 40AH2W-30	Attenuator 30dB 2.92mm 40GHz	28-Mar-22	28-Mar-23
54392	HUBER + SUHNER/ Sucoflex 102	K Type 40 GHz Cable	08-Feb-22	08-Feb-23
54394	HUBER + SUHNER/ Sucoflex 102	K Type 40 GHz Cable	08-Feb-22	08-Feb-23
54398	HUBER + SUHNER/ Sucoflex 102	K Type 40 GHz Cable	08-Feb-22	08-Feb-23
54408	HUBER + SUHNER/ Sucoflex 102E	40GHz Cable K Connector	09-Feb-22	09-Feb-23
54415	HUBER + SUHNER/ Sucoflex 102E	40GHz Cable K Connector	11-Feb-22	11-Feb-23
54628	MEGAPHASE/RA08-S1S1-36	SMA Cable	15-Feb-22	15-Feb-23
54637	MINI-CIRCUITS/ BW-S30W2 +	30dB SMA Attenuator	25-Mar-22	25-Mar-23
54661	MINI-CIRCUITS/ BW-S30W2 +	30dB SMA Attenuator	25-Mar-22	25-Mar-23
54695	DITOM/ D3C2060	Circulator	08-Mar-22	08-Mar-23
55365	PULSAR/ PS4-09-452/4S	4-way Splitter	16-Sep-22	16-Sep-23
55582	MINI-CIRCUITS/ BW-S30W2 +	30dB SMA Attenuator	25-Mar-22	25-Mar-23
55584	MINI-CIRCUITS/ BW-S30W2 +	30dB SMA Attenuator	25-Mar-22	25-Mar-23
56330	Pasternack/ PE5019-1	Torque Wrench	06-May-22	06-May-23
57224	NATIONAL INSTRUMENTS/ PXI-5422	DFS card	28-Nov-22	28-Nov-23
57240	NATIONAL INSTRUMENTS/ PXI-8115	Embedded controller	Cal Not Req'd	N/A
57271	NATIONAL INSTRUMENTS/ PXI-5422	DFS card	28-Nov-22	28-Nov-23
58223	Comet/T7611-4	WEB SENSOR FOR REMOTE THERMOMETER HYGROMETER	11-Aug-22	11-Aug-23
58272	KRYTAR/ 1850	500MHz to 18.5 GHz SMA Directional Coupler	16-Sep-22	16-Sep-23
58282	PULSAR/ PS4-09-452/4S	4-way Splitter	16-Sep-22	16-Sep-23
62403	HUBER + SUHNER/ SF102E	RF Coaxial Cable to 40GHz, 0.457m	08-Feb-22	08-Feb-23
62404	HUBER + SUHNER/ SF102E	RF Coaxial Cable to 40GHz, 0.457m	08-Feb-22	08-Feb-23
62405	HUBER + SUHNER/ SF102E	RF Coaxial Cable to 40GHz, 0.457m	08-Feb-22	08-Feb-23
62406	HUBER + SUHNER/ SF102E	RF Coaxial Cable to 40GHz, 0.457m	08-Feb-22	08-Feb-23
62407	HUBER + SUHNER/ SF102E	RF Coaxial Cable to 40GHz, 0.457m	07-Feb-22	07-Feb-23
62408	HUBER + SUHNER/ SF102E	RF Coaxial Cable to 40GHz, 0.457m	08-Feb-22	08-Feb-23
62409	HUBER + SUHNER/ SF102E	RF Coaxial Cable to 40GHz, 0.457m	07-Feb-22	07-Feb-23
62410	HUBER + SUHNER/ SF102E	RF Coaxial Cable to 40GHz, 0.457m	08-Feb-22	08-Feb-23



## Appendix D: Photographs of Test Setups

Please refer to Photo Exhibit (EDCS#23938748)

## Appendix E: Software Used to Perform Testing

Cisco Internal LabView Radio Test Automation Software – DFS Automation Main rev 168 (Zero Wait DFS)

## Appendix F: Test Procedures

Measurements were made in accordance with:

- KDB 905462 D02 UNII DFS Compliance Procedures New Rules v02

Test procedures are summarized below:

FCC DFS Test Procedures	EDCS # 1445052
Zero Wait DFS (CAC detection)	TCB Workshop Guidance April 11, 2018 presentation covering "Zero Wait DFS" presented by Dusmantha Tennakoon. See slide 3.

## Appendix G: Scope of Accreditation (A2LA certificate number 1178-01)

The scope of accreditation of Cisco Systems, Inc. can be found on the A2LA web page at:

<http://www.a2la.org/scopepdf/1178-01.pdf>

## Appendix H: Test Assessment Plan

Compliance Test Plan (Excel) EDCS# 20045966

Radio Test Plan: EDCS# 23497693

## Appendix I: Worst Case Justification

N/A

## Appendix J: UUT Software Info

Cisco AP Software, (ap1g6a), [cheetah-build9:/san1/BUILD/workspace/master-cisco\_mfg/label/mfg-ap1g6a]

Technical Support: <http://www.cisco.com/techsupport>

Copyright (c) 1986-2022 by Cisco Systems, Inc.

Compiled Sat Nov 26 00:25:58 GMT 2022

ROM: Bootstrap program is U-Boot boot loader

BOOTLDR: U-Boot boot loader Version U-Boot DEV 2016.01 (btldr release 36) (Oct 17 2022 - 16:38:49 -0700)