

5925-6425MHz Formal Test Report for IW9165DH-B & IW9165DH-ROW

Supports

BLE/4.9GHz/ 5GHz 802.11 a/ac/ax/n and 6 GHz Wi-Fi radio

FCC ID: LDKIW9165DH

Against the following Specifications:



47 CFR 15.205

47 CFR 15.209

47 CFR 15.407

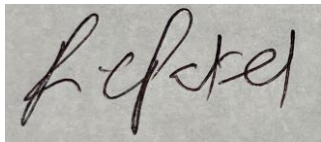

Cisco Systems, Inc.
170 West Tasman Drive
San Jose, CA 95134

	
Author: Ronak Patel Tested By: Ronak Patel	Approved By: Adam Walb Title: Compliance Manager Revision: 1.0

This report replaces any previously entered test report under **EDCS # 24733417**. This test report has been electronically authorized and archived using the CISCO Engineering Document Control system. Test Report Template EDCS# 11644120.

SECTION 1: OVERVIEW	3
SECTION 2: ASSESSMENT INFORMATION	4
2.1: GENERAL.....	4
2.2: DATE OF TESTING	5
2.3: REPORT ISSUE DATE	5
2.4: TESTING FACILITIES	5
2.5: EQUIPMENT ASSESSED (EUT).....	6
2.6: EUT DESCRIPTION	6
SECTION 3: RESULT SUMMARY	8
3.1: RESULTS SUMMARY TABLE.....	8
SECTION 4: SAMPLE DETAILS	10
4.1: SAMPLE DETAILS.....	10
4.2: SYSTEM DETAILS.....	10
4.3: MODE OF OPERATION DETAILS	10
APPENDIX A: EMISSION TEST RESULTS	11
A.1: DUTY CYCLE	12
A.2: 99% AND 26DB BANDWIDTH	16
A.3: MAXIMUM CONDUCTED OUTPUT POWER	24
A.4: POWER SPECTRAL DENSITY.....	41
A.5: CONDUCTED SPURIOUS EMISSIONS	48
A.6: CONDUCTED BAND EDGE (IN-BAND EMISSIONS)	63
APPENDIX B: EMISSION TEST RESULTS	78
B.1: RADIATED SPURIOUS EMISSIONS.....	79
B.2: RADIATED EMISSIONS 30MHZ TO 1GHZ	79
B.3: AC CONDUCTED EMISSIONS	80
APPENDIX C: LIST OF TEST EQUIPMENT USED TO PERFORM THE TEST	85
APPENDIX D: ABBREVIATION KEY AND DEFINITIONS	87
APPENDIX E: PHOTOGRAPHS OF TEST SETUPS	88
APPENDIX F: SOFTWARE USED TO PERFORM TESTING	88
APPENDIX G: TEST PROCEDURES	88
APPENDIX H: SCOPE OF ACCREDITATION (A2LA CERTIFICATE NUMBER 1178-01)	88
APPENDIX I: TEST ASSESSMENT PLAN	88
APPENDIX J: WORST CASE JUSTIFICATION	88

Section 1: Overview

The samples were assessed against the tests detailed in section 3 under the requirements of the following specifications:

Specifications:
CFR47 Part 15.407

Section 2: Assessment Information

2.1: General

This report contains an assessment of an apparatus against Electromagnetic Compatibility Standards based upon tests carried out on the samples submitted. The testing was performed by and for the use of Cisco systems Inc:

With regard to this assessment, the following points should be noted:

- a) The results contained in this report relate only to the items tested and were obtained in the period between the date of the initial assessment and the date of issue of the report. Manufactured products will not necessarily give identical results due to production and measurement tolerances.
- b) The apparatus was set up and exercised using the configuration and modes of operation defined in this report only.
- c) Where relevant, the apparatus was only assessed using the susceptibility criteria defined in this report and the Test Assessment Plan (TAP).
- d) All testing was performed under the following environmental conditions:

Temperature	15 °C to 35 °C (54 °F to 95 °F)
Atmospheric Pressure	860 mbar to 1060 mbar (25.4" to 31.3")
Humidity	10% to 75*%

- e) All AC testing was performed at one or more of the following supply voltages:

110V 60 Hz (+/-20%)

Units of Measurement

The units of measurements defined in the appendices are reported in specific terms, which are test dependent. Where radiated measurements are concerned these are defined at a particular distance. Basic voltage measurements are defined in units of [dBuV]

As an example, the basic calculation for all measurements is as follows:

$$\text{Emission level [dBuV]} = \text{Indicated voltage level [dBuV]} + \text{Cable Loss [dB]} + \text{Other correction factors [dB]}$$

The combinations of correction factors are dependent upon the exact test configurations [see test equipment lists for further details] and may include:

Antenna Factors, Pre-Amplifier Gain, LISN Loss, Pulse Limiter Loss and Filter Insertion Loss

Note: To convert the results from dBuV/m to uV/m use the following formula:

$$\text{Level in uV/m} = \text{Common Antilogarithm} [(X \text{ dBuV/m})/20] = Y \text{ uV/m}$$

Measurement Uncertainty Values

voltage and power measurements	± 2 dB
conducted EIRP measurements	± 1.4 dB
radiated measurements	± 3.2 dB
frequency measurements	± 2.4 10 ⁻⁷
temperature measurements	± 0.54°
humidity measurements	± 2.3%
DC and low frequency measurements	± 2.5%

Where relevant measurement uncertainty levels have been estimated for tests performed on the apparatus. This uncertainty represents an expanded uncertainty expressed at approximately the 95% confidence level using a coverage factor of $k=2$.

Radiated emissions (expanded uncertainty, confidence interval 95%)

30 MHz – 300 MHz	± 3.8 dB
300 MHz – 1000 MHz	± 4.3 dB
1 GHz – 10 GHz	± 4.0 dB
10 GHz – 18GHz	± 8.2 dB
18GHz – 26.5GHz	± 4.1 dB
26.5GHz – 40GHz	± 3.9 dB

Conducted emissions (expanded uncertainty, confidence interval 95%)

30 MHz – 40 GHz	± 0.38 dB
-----------------	-----------

A product is considered to comply with a requirement if the nominal measured value is below the limit line. The product is considered to not be in compliance in case the nominal measured value is above the limit line.

This report must not be reproduced except in full, without written approval of Cisco Systems.

2.2: Date of testing

11/28/2023 – 12/01/2023

2.3: Report Issue Date

1/19/2024

Cisco uses an electronic system to issue, store and control the revision of test reports. This system is called the Engineering Document Control System (EDCS). The actual report issue date is embedded into the original file on EDCS. Any copies of this report, either electronic or paper, that are not on EDCS must be considered uncontrolled.

2.4: Testing facilities

This assessment was performed by: NIST Designated Phase-I and Phase-II Conformity Assessment Body (CAB) for the following economies and regulatory authorities under the terms of the stated MRAs/Treaties: NCC (National Communications Commission) APEC Tel MRA – Phase I.

Testing Laboratory
Cisco Systems, Inc.
125 West Tasman Drive (Building P)
San Jose, CA 95134
USA

Headquarters
Cisco Systems, Inc.,
170 West Tasman Drive
San Jose, CA 95134,
USA

Registration Number

Cisco System Site	Address	Site Identifier
Building P, 10m Chamber	125 West Tasman Dr San Jose, CA 95134	Company #: 2461A

Test Engineer(s):

Ronak Patel

2.5: Equipment Assessed (EUT)

IW9165DH-B

2.6: EUT Description

RF General Information			
Evaluation Mode	Frequency Range (MHz)	Operating Frequency (MHz)	Modulation Type
5GHz WLAN	5150-5250 5250-5350 5470-5725 5725-5850	5180-5250 5250-5320 5500-5720 5745-5825	802.11a/n: OFDM (BPSK, QPSK, 16QAM, 64QAM) 802.11ac: OFDM (BPSK, QPSK, 16QAM, 64QAM, 256QAM) 802.11ax: OFDMA (BPSK, QPSK, 16QAM, 64QAM, 256QAM, 1024QAM)
4.9GHz WLAN	4940-4990	4945-4985	OFDM (BPSK, QPSK, 16QAM, 64QAM)
Bluetooth	2400-2483.5	2402-2480	LE: GFSK
6GHz WLAN	5925-6425MHz 6525-6875MHz	5925-6425MHz 6525-6875MHz	802.11ax: OFDMA (BPSK, QPSK, 16QAM, 64QAM, 256QAM, 1024QAM)

R1	-	V (AP: 20/40/80) (P2P/P2MP: 20/40/80)	V	-	-	-
R2	-	V (AP: 20/40/80/160) (P2P/P2MP: 20/40/80/160)	V	-	-	-
R3	-	-	-	-	V	-
R4	-	-	-	-	-	V

For Radio1 - 5GHz UNII 1~UNII 3 and 4.9GHz:**For IEEE 802.11a/n/ac/ax mode (1TX, 2TX/2RX):****1TX**

Only Port 1 can be use as transmitting antenna.

2TX

Port 1, Port 2 can be use as transmitting antenna. Port 1, Port 2 could transmit simultaneously.

2RX

Port 1, Port 2, Port 3, Port 4 can be used as receiving antennas. Port 1 and Port 2 could receive simultaneously.

For Radio 2 - 5GHz UNII 1~UNII 3, 4.9GHz & UNI 5 ~ UNII 7:**For IEEE 802.11a/n/ac/ax mode (1TX, 2TX/2RX):****1TX**

Only Port 1 can be use as transmitting antenna.

2TX

Port 1, Port 2 can be use as transmitting antenna. Port 1, Port 2 could transmit simultaneously.

2RX

Port 1, Port 2, Port 3, Port 4 can be used as receiving antennas. Port 1 and Port 2 could receive simultaneously.

For Radio 3 - BLE**Bluetooth(1TX):**

Only Port 1 can be used as transmitting/receiving antenna.

For Radio 4 – GNSS (1Rx)

Only Port 1 can be used as receiving antenna.

The following antennas are supported by this product series. Please note, the antenna information has been provided by the customer (the Cisco business unit). The data included in this report represent the worst-case data for all antennas.

Magnum IW9165 Supported External Antenna List

Product ID	Family	Description	Supported by IW9165DHD?	Supported by IW9165E?	Peak Gain 2.4 GHz (dBi)	Peak Gain 4.9 GHz (dBi)	Peak Gain 5 GHz (dBi)	Gain > 30° Elevation UNII-1 (dBi)	Peak Gain 6 GHz (dBi)	Gain > 30° Elevation UNII-5 & 7	5 GHz Fixed Point-to-Point?	5 GHz Point-to-Multipoint?
IW-ANT-OMM-53-N=	Legacy	5 GHz 3 dBi Omnidirectional Antenna, Multi-polarized, N Female Connector	No	Yes	N/A	3	3	0	N/A	N/A	No	Yes
AIR-ANT5180V-N=	Legacy	5 GHz 8 dBi Omnidirectional Colinear Array Antenna, N Male Connector	Yes	Yes	N/A	8	8	-3	N/A	N/A	No	Yes
IW-ANT-PNL-59-N=	Legacy	5 GHz 9 dBi 2-Element Patch Array Antenna, Slant ±45 Polarized, N Female Connectors	Yes	Yes	N/A	N/A	10	7	N/A	N/A	Yes	Yes
AIR-ANT5114P2M-N=	Legacy	5 GHz 13 dBi 2-Element Patch Array Antenna, N Male Connectors	Yes	Yes	N/A	N/A	13	4	N/A	N/A	Yes	Yes
AIR-ANT5114P2M-NS=	SIA	5 GHz 13 dBi 2-Element Patch Array Antenna, N Male Connectors	Yes	Yes	N/A	N/A	13	3	N/A	N/A	Yes	Yes
IW-ANT-SKD-513-Q=	Legacy	5 GHz 14 dBi 2-Element Shark Antenna, Slant ±45 Polarized, QMA Female Connectors	No	Yes	N/A	13	13	8	N/A	N/A	No	Yes
IW-ANT-SKS-514-Q=	Legacy	5 GHz 14 dBi 2-Element Shark Antenna, Slant ±45 Polarized, QMA Female Connectors	No	Yes	N/A	13	13	8	N/A	N/A	No	Yes
AIR-ANT2547V-N=	Legacy	2.4 GHz 4 dBi / 5 GHz 7 dBi Omnidirectional Colinear Array Antenna, N male connector	Yes	Yes	4	N/A	7	-3	N/A	N/A	No	Yes
AIR-ANT2547VG-N=	Legacy	2.4 GHz 4 dBi / 5 GHz 7 dBi Omnidirectional Colinear Array	Yes	Yes	4	N/A	7	-3	N/A	N/A	No	Yes
AIR-ANT2547VG-NS=	SIA	2.4 GHz 4 dBi / 5 GHz 7 dBi Omnidirectional Colinear Array	Yes	Yes	4	N/A	7	-3	N/A	N/A	No	Yes
AIR-ANT2588VG-N=	Legacy	2.4 GHz 6 dBi / 5 GHz 8 dBi Omnidirectional Antenna, N Male	Yes	Yes	6	N/A	8	3	N/A	N/A	No	Yes
AIR-ANT2588VG-NS=	SIA	2.4 GHz 6 dBi / 5 GHz 8 dBi Omnidirectional Antenna, N Male	Yes	Yes	6	N/A	8	3	N/A	N/A	No	Yes
AIR-ANT2588P4M-NS=	SIA	2.4 GHz 8 dBi / 5 GHz 8 dBi 4-Element Dual-Polarized Patch Antenna, N	No	Yes	8	N/A	8	-2	N/A	N/A	No	Yes
AIR-ANT2513P4M-N=	Legacy	2.4 GHz 13 dBi / 5 GHz 13 dBi Polarization Diverse Patch Array	No	Yes	13	N/A	13	1	N/A	N/A	Yes	Yes
AIR-ANT2513P4M-NS=	SIA	2.4 GHz 13 dBi / 5 GHz 13 dBi Polarization Diverse Patch Array	No	Yes	13	N/A	13	1	N/A	N/A	Yes	Yes
IW-ANT-OMV-2567-N	SIA	Tri-band 2.4 GHz 4 dBi, 5/6 GHz 7 dBi Omnidirectional Colinear Array Antenna, Vertically Polarized, N Male Connector	Yes	Yes	4	7	7	-7	7	-6	No	Yes
IW-ANT-OMH-2567-N	SIA	Tri-band 2.4 GHz 4 dBi, 5/6 GHz 7 dBi Omnidirectional Colinear Array Antenna, Horizontally Polarized, N Male Connector	Yes	Yes	4	7	7	-6	7	-4	No	Yes
IW-ANT-PNL-515-N=	SIA	Tri-band 5 GHz 15dBi Panel Antenna	Yes	Yes		15	15	3			Yes	Yes

Section 3: Result Summary

3.1: Results Summary Table

Conducted test summary.

Basic Standard	Technical Requirements / Details	Result
FCC 15.407 Clause (a)(10)	<p>99%- & 26-dB Bandwidth: The 99% occupied bandwidth is the frequency bandwidth such that, below its lower and above its upper frequency limits, the mean powers are each equal to 0.5% of the total mean power of the given emission. There is no limit for 99% OBW.</p> <p>The 26 dB emission is the width of the emission that is constrained by the frequencies associated with the two outermost amplitude points (upper and lower frequencies) that are attenuated by 26 dB relative to the maximum level measured in the fundamental emission.</p> <p>The maximum transmitter channel bandwidth for U-NII devices in the 5.925–7.125 GHz band is 320 megahertz.</p>	Pass
FCC 15.407 Clause (a)(4)	<p>Output Power: For a standard power access point and fixed client device operating in the 5.925–6.425 GHz and 6.525–6.875 GHz bands, the maximum e.i.r.p. over the frequency band of operation must not exceed 36 dBm. For outdoor devices, the maximum e.i.r.p. at any elevation angle above 30 degrees as measured from the horizon must not exceed 125 mW (21 dBm)</p>	Pass
15.407 Clause (a)(4)	<p>Power Spectral Density: For a standard power access point and fixed client device operating in the 5.925–6.425 GHz and 6.525–6.875 GHz bands, the maximum power spectral density must not exceed 23 dBm e.i.r.p in any 1-megahertz band</p>	Pass
15.407 Clause (b)(6)	<p>Conducted Spurious Emissions: For transmitters operating within the 5.925–7.125 GHz band: Any emissions outside of the 5.925–7.125 GHz band must not exceed an e.i.r.p. of –27 dBm/MHz</p>	Pass
15.407 Clause (b)(7)	<p>Conducted Band Edge/ Spectral Mask: For transmitters operating within the 5.925–7.125 GHz bands: Power spectral density must be suppressed by 20 dB at 1 MHz outside of channel edge, by 28 dB at one channel bandwidth from the channel center, and by 40 dB at one- and one-half times the channel bandwidth away from channel center. At frequencies between one megahertz outside an unlicensed device's channel edge and one channel bandwidth from the center of the channel, the limits must be linearly interpolated between 20 dB and 28 dB suppression, and at frequencies between one and one- and one-half times an unlicensed device's channel bandwidth, the limits must be linearly interpolated between 28 dB and 40 dB suppression. Emissions removed from the channel center by more than one- and one-half times the channel bandwidth must be suppressed by at least 40 dB</p>	
FCC 15.407 FCC 15.209 FCC 15.205 Clause (b)(9)(10)	<p>Restricted band: Unwanted emissions falling within the restricted bands, as defined in FCC 15.205 (a) must also comply with the radiated emission limits specified in FCC 15.209 (a).</p>	Pass

Radiated Emissions (General requirements)

Basic Standard	Technical Requirements / Details	Result
FCC 15.407 FCC 15.205 FCC 15.209 Clause (b)(9)(10)	TX Spurious Emissions: Unwanted emissions must comply with the general field strength limits set forth in §15.209. (7) The provisions of §15.205 apply to intentional radiators operating under this section.	[EDCS # 24733400]
FCC 15.207 Clause (b)(9)	AC conducted Emissions: Except when the requirements applicable to a given device state otherwise, for any radio apparatus equipped to operate from the public utility AC power supply, either directly or indirectly (such as with a battery charger), the radio frequency voltage of emissions conducted back onto the AC power lines in the frequency range of 0.15 MHz to 30 MHz shall not exceed the limits shown in the table in these sections. The more stringent limit applies at the frequency range boundaries.	Pass

* MPE calculation is recorded in a separate report

Section 4: Sample Details

Note: Each sample was evaluated to ensure that its condition was suitable to be used as a test sample prior to the commencement of testing.

4.1: Sample Details

Sample No.	Equipment Details	Manufacturer	Hardware Rev.	Firmware Rev.	Software Rev.	Serial Number
S01	IW9165DH-B	Cisco Systems	PILOT	QC_IMAGE_VERSION_STRING=WLAN.HK.2.4-02142-QCAHKSWPL_SILICONZ-1	[sjc-ads-5692:/nobackup/zhiyin/m22-ws]	FOC27095C9Z
S02	IW-PWRADPT-MFIT4P	Cisco Systems	V00	-	-	LIN264450C6

4.2: System Details

System #	Description	Samples
1	IW9165DH-B	S01
2	IW-PWRADPT-MFIT4P	S02

4.3: Mode of Operation Details

Mode#	Description	Comments
1	Continuous Transmitting	

Function	Support Band
AP	BLE,5GHz,6GHz & 4.9GHz
P2P/P2MP	5GHz, 6GHz and 4.9GHz

Appendix A: Emission Test Results

Conducted Test Setup Diagram

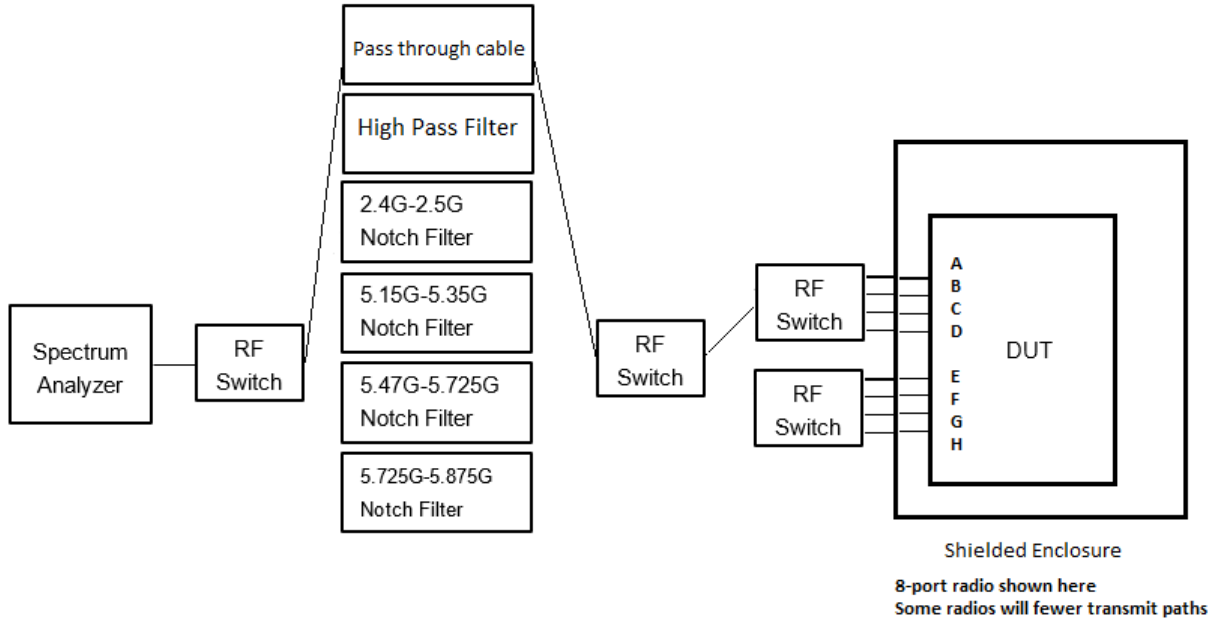

Test Setup Description

The EUT was placed inside an RF shielded enclosure. RF cables connect to each antenna port on the EUT inside the enclosure. Those cables are routed to RF switch cards in a National Instruments chassis. There are different paths, some paths contain a notch filter or high pass filter as shown above. The signal is then routed to the spectrum analyzer where measurements are made.

Plots listed herein represent the measured worst-case per antenna, frequency, and modulation.

A.1: Duty Cycle

Duty Cycle Test Requirement

987594 D02 U-NII 6 GHz EMC Measurement v02r01 II (B)

From KDB 789033 D02 General UNII Test Procedures New Rules v02r01

B. Duty Cycle (x), Transmission Duration (T), and Maximum Power Control Level

1. All measurements are to be performed with the EUT transmitting at 100 percent duty cycle at its maximum power control level; however, if 100 percent duty cycle cannot be achieved, measurements of duty cycle, x , and maximum-power transmission duration, T , are required for each tested mode of operation.

Duty Cycle Test Method

From KDB 789033 D02 General UNII Test Procedures New Rules v02r01:

B. Duty Cycle (x), Transmission Duration (T), and Maximum Power Control Level

The zero-span mode on a spectrum analyzer or EMI receiver, if the response time and spacing between bins on the sweep are sufficient to permit accurate measurements of the on and off times of the transmitted signal. Set the center frequency of the instrument to the center frequency of the transmission. Set $RBW \geq EBW$ if possible; otherwise, set RBW to the largest available value. Set $VBW \geq RBW$. Set detector = peak or average. The zero-span measurement method shall not be used unless both RBW and VBW are $> 50/T$, where T is defined in section II.B.1.a), and the number of sweep points across duration T exceeds 100. (For example, if VBW and/or RBW are limited to 3 MHz, then the zero-span method of measuring duty cycle shall not be used if $T \leq 16.7$ microseconds.)

Duty Cycle Test Information

Tested By: Ronak Patel	Date of testing: 11/28/2023 – 12/01/2023
Test Result: PASS	

Test Equipment

See Appendix C for list of test equipment.

Duty Cycle Data Table

Duty Cycle table and screen captures are shown below for Power/PSD modes.

Frequency (MHz)	Mode	Data Rate (Mbps)	Duty Cycle (dB)
5955	HE20, M0 to M11 1ss	m0h1	0.12
5965	HE40, M0 to M11 1ss	m0h1	0.19
5985	HE80, M0 to M11 1ss	m0h1	0.25
6025	HE160, M0 to M11 1ss	m0h1	0.32
6175	HE20, M0 to M11 1ss	m0h1	0.12
6185	HE160, M0 to M11 1ss	m0h1	0.32
6205	HE40, M0 to M11 1ss	m0h1	0.19
6225	HE80, M0 to M11 1ss	m0h1	0.25
6345	HE160, M0 to M11 1ss	m0h1	0.32
6385	HE80, M0 to M11 1ss	m0h1	0.25
6405	HE40, M0 to M11 1ss	m0h1	0.19
6415	HE20, M0 to M11 1ss	m0h1	0.12

Data Screenshots

5955 MHz: HE20, M0 to M11 1ss - Antenna A

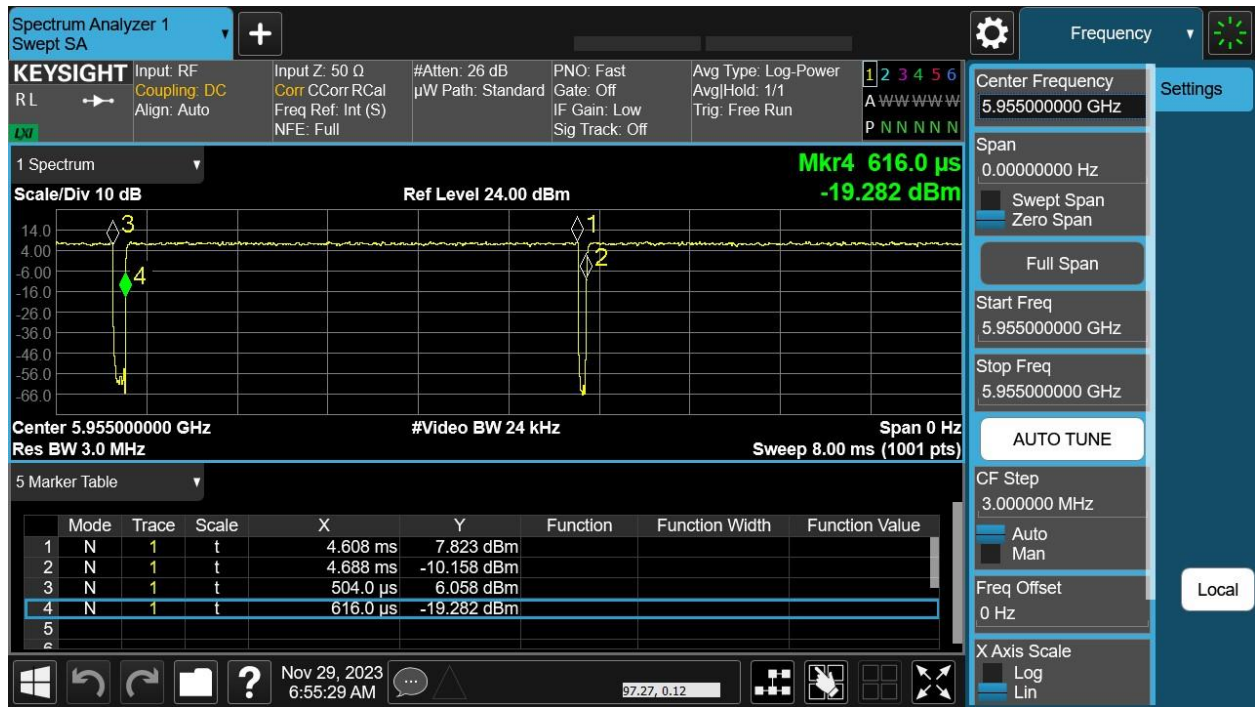

5965 MHz: HE40, M0 to M11 1ss - Antenna A

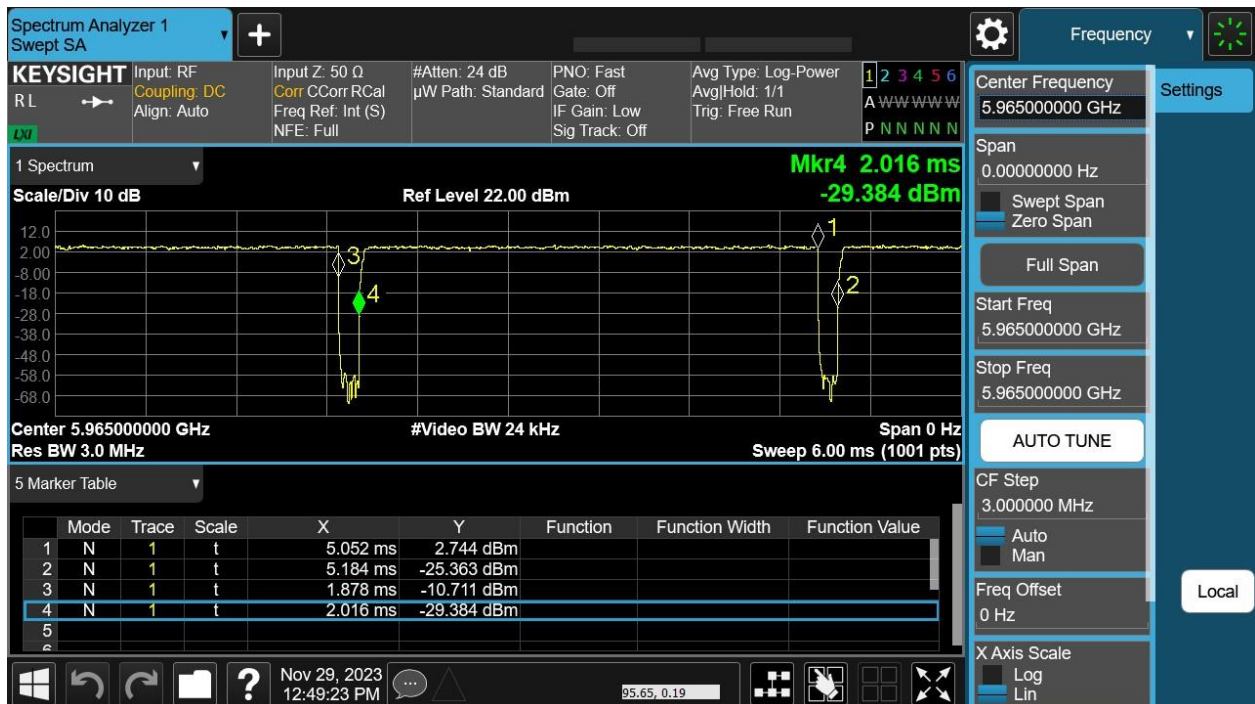

5985 MHz: HE80, M0 to M11 1ss – Antenna A

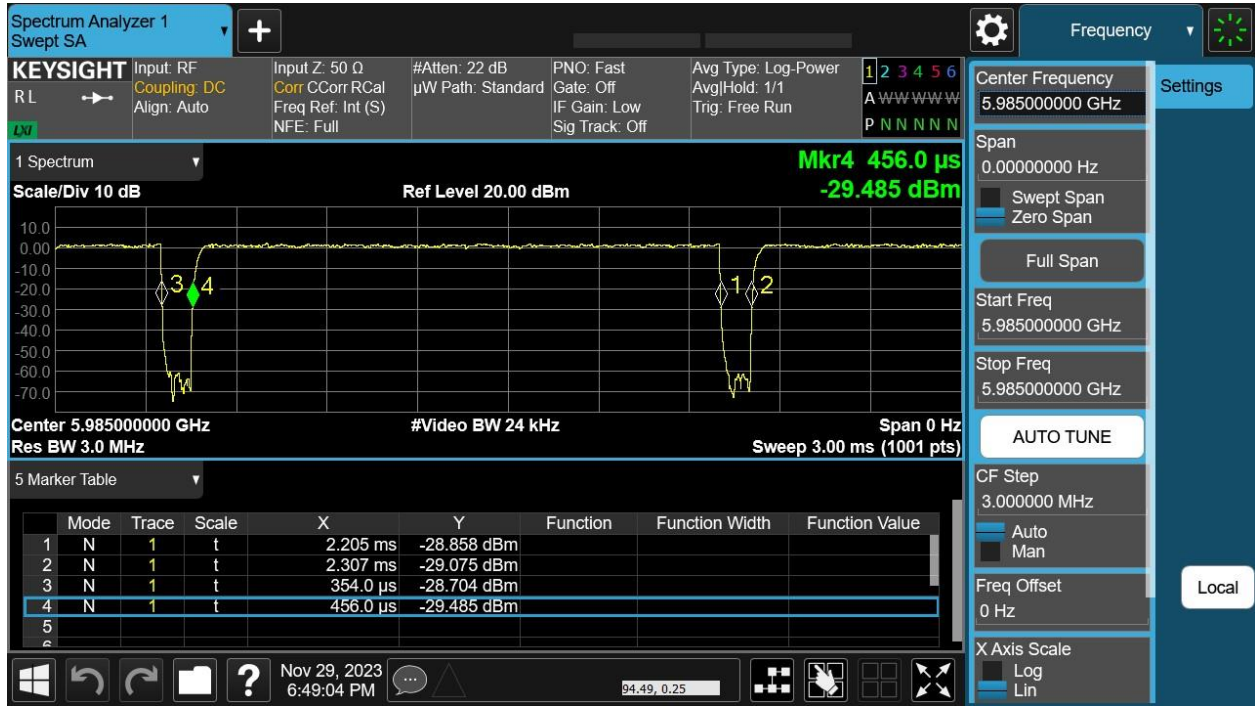

6025 MHz: HE160, M0 to M11 1ss – Antenna A

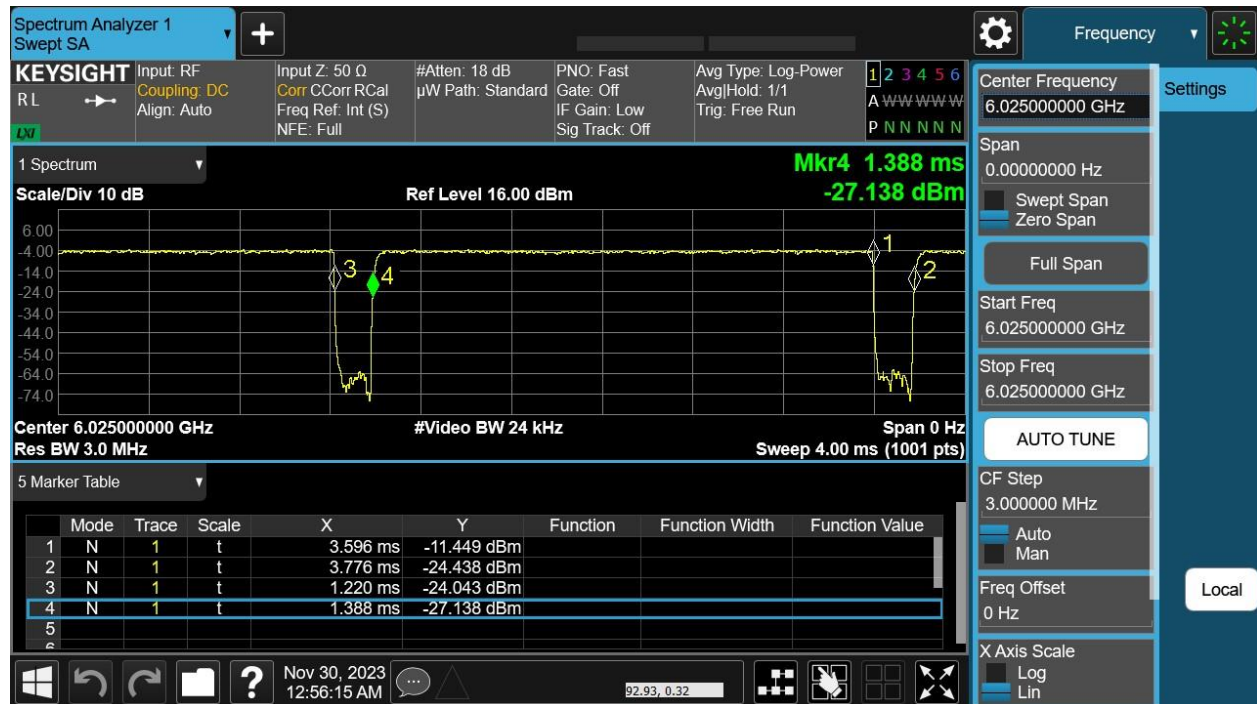

A.2: 99% and 26dB Bandwidth**99% and 26dB Bandwidth Test Requirement**

For the FCC:

There is no requirement for the value of bandwidth.

Power measurements are made using the 99% Bandwidth as the integration bandwidth.

99% and 26dB Bandwidth Test Procedure

The 99-percent occupied bandwidth is the frequency bandwidth such that, below its lower and above its upper frequency limits, the mean powers are each equal to 0.5 % of the total mean power of the given emission. Measurement of the 99-percent occupied bandwidth is required only as a condition for using the optional band-edge measurement techniques described in section II.G.3.d). Measurements of 99-percent occupied bandwidth may also optionally be used in lieu of the EBW to define the minimum frequency range over which the spectrum is integrated when measuring maximum conducted output power as described in section II.E. However, the EBW must be measured to determine bandwidth dependent limits on maximum conducted output power in accordance with 15.407(a).

Ref. KDB 789033 Section D. 99 Percent Occupied Bandwidth

99% BW
Test Parameters
<ol style="list-style-type: none"> 1. Set center frequency to the nominal EUT channel center frequency. 2. Set span = 1.5 times to 5.0 times the OBW. 3. Set RBW = 1 % to 5 % of the OBW 4. Set VBW $\geq 3 \cdot$ RBW. Video averaging is not permitted. Where practical, a sample detection and single sweep mode shall be used. Otherwise, peak detection and max hold mode (until the trace stabilizes) shall be used. 6. Use the 99 % power bandwidth function of the instrument (if available).

Ref KDB 789033 in Section C. Measurement Bandwidth, Section 1

26 BW
Test parameters
<p>X dB BW = -26dB (using the OBW function of the spectrum analyzer)</p> <p>Emission Bandwidth (EBW)</p> <ol style="list-style-type: none"> a) Set RBW = approximately 1% of the emission bandwidth. b) Set the VBW > RBW. c) Detector = Peak. d) Trace mode = max hold. e) Measure the maximum width of the emission that is 26 dB down from the maximum of the emission. Compare this with the RBW setting of the analyzer. Readjust RBW and repeat measurement as needed until the RBW/EBW ratio is approximately 1%.

Tested By: Ronak Patel	Date of testing: 11/28/2023 – 12/01/2023
Test Result: PASS	

Test Equipment

See Appendix C for list of test equipment.

99% and 26dB Bandwidth Table

Frequency (MHz)	Mode	Data Rate (Mbps)	26dB BW (MHz)	99% BW (MHz)
5955	HE20, M0 to M11 1ss	m0h1	21.50	18.95
5965	HE40, M0 to M11 1ss	m0h1	40.90	37.74
5985	HE80, M0 to M11 1ss	m0h1	84.00	77.14
6025	HE160, M0 to M11 1ss	m0h1	166.40	154.83
6175	HE20, M0 to M11 1ss	m0h1	21.30	18.94
6185	HE160, M0 to M11 1ss	m0h1	167.00	155.13
6205	HE40, M0 to M11 1ss	m0h1	41.00	37.78
6225	HE80, M0 to M11 1ss	m0h1	83.90	77.24
6345	HE160, M0 to M11 1ss	m0h1	166.60	154.82
6385	HE80, M0 to M11 1ss	m0h1	83.70	77.18
6405	HE40, M0 to M11 1ss	m0h1	40.80	37.71
6415	HE20, M0 to M11 1ss	m0h1	21.40	18.95

Data Screenshots

5955 MHz: HE20, M0 to M11 1ss – Antenna A

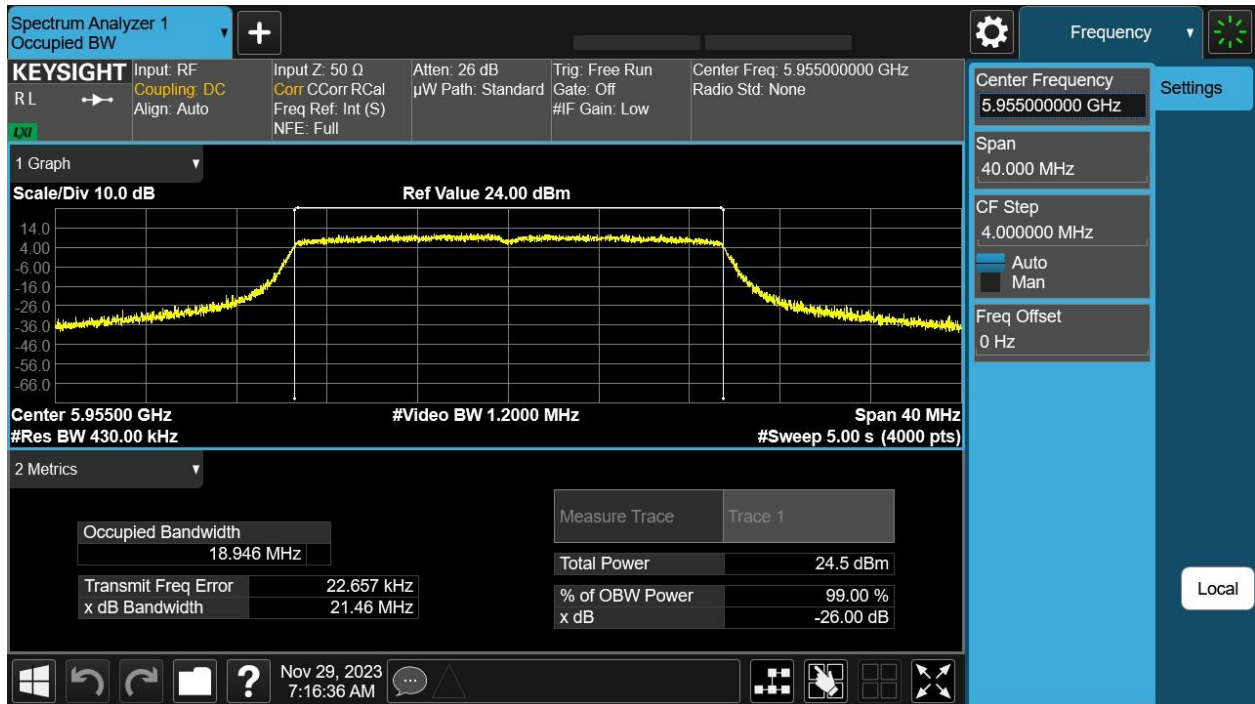

6175 MHz: HE20, M0 to M11 1ss - Antenna A

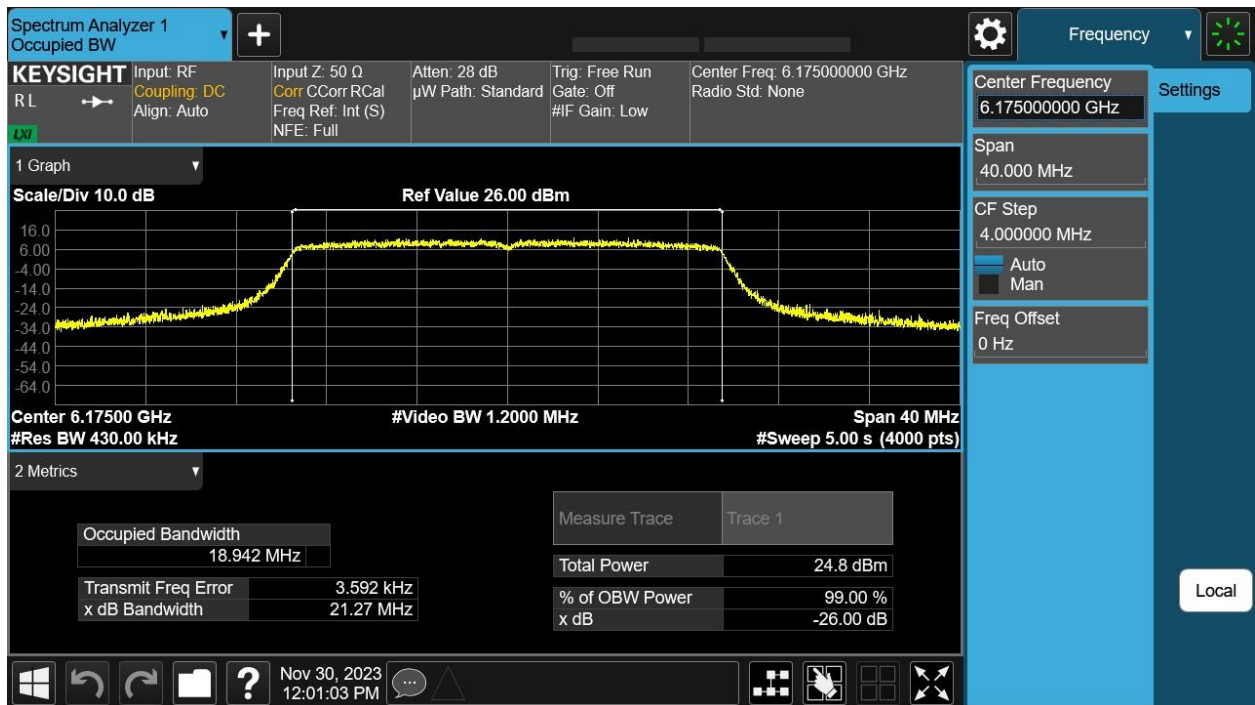

6415 MHz: HE20, M0 to M11 1ss - Antenna A

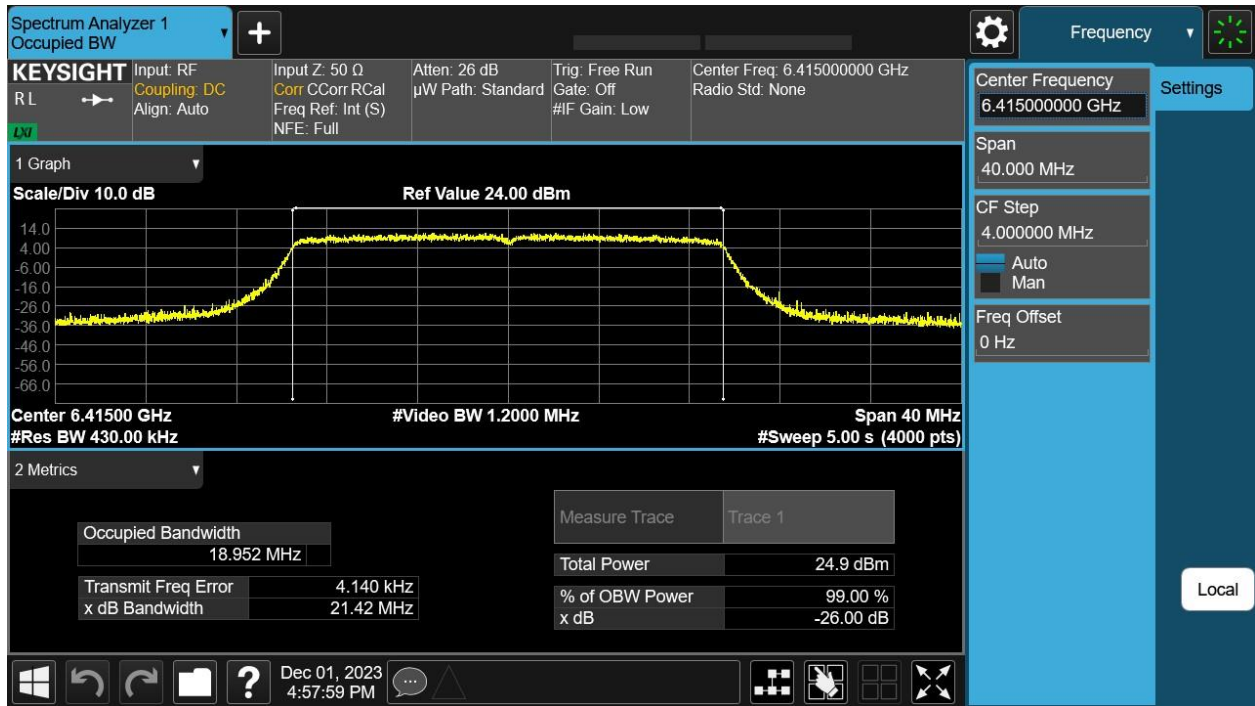

5965 MHz: HE40, M0 to M11 1ss – Antenna A

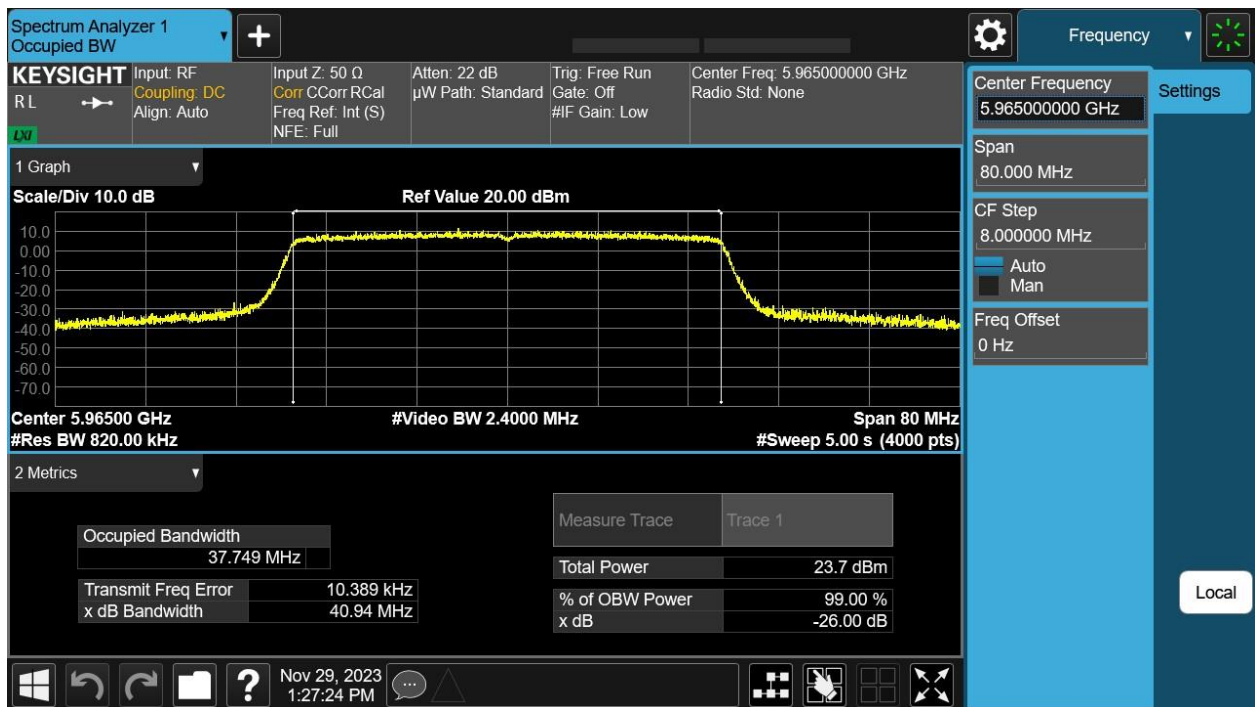

6205 MHz: HE40, M0 to M11 1ss – Antenna A



6405 MHz: HE40, M0 to M11 1ss – Antenna A

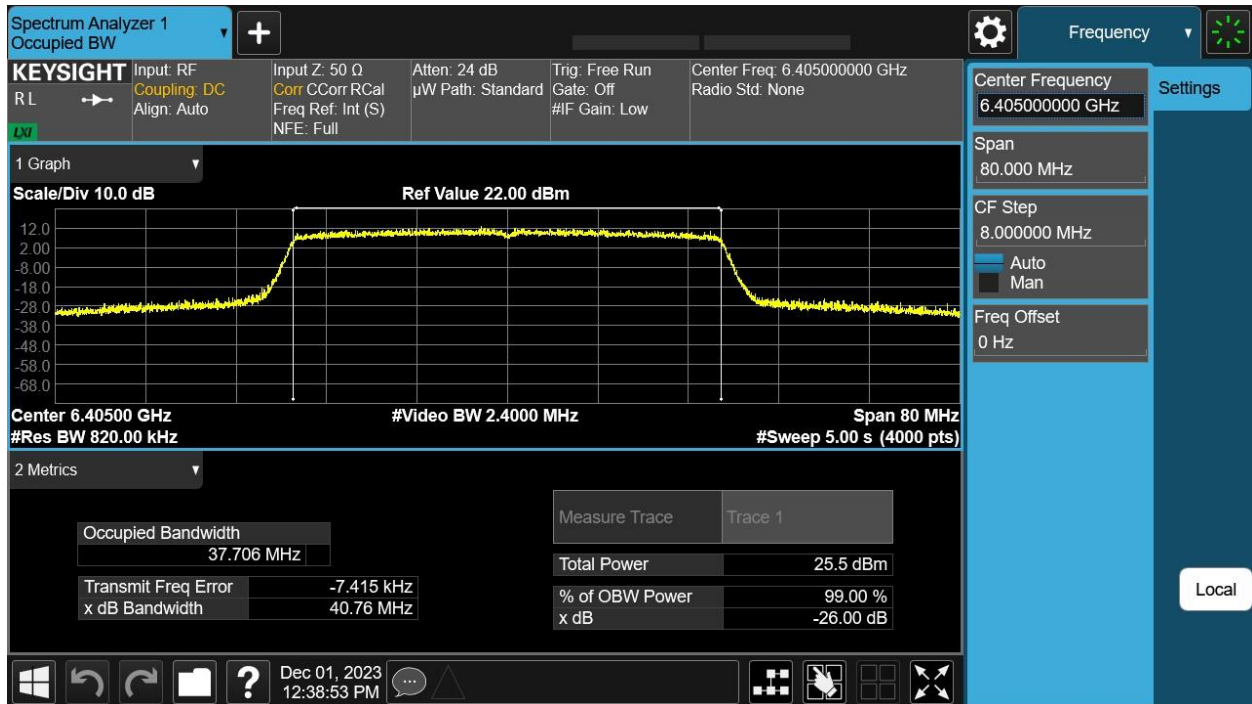

5985 MHz: HE80, M0 to M11 1ss - Antenna A

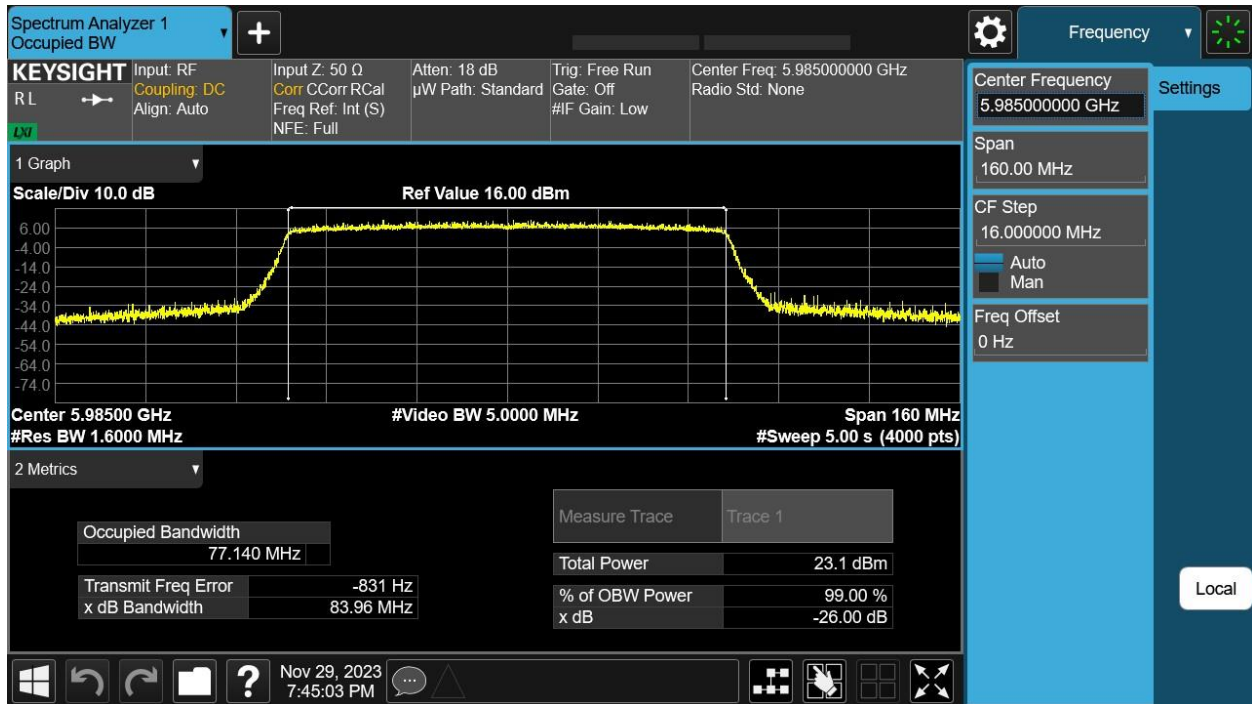

6225 MHz: HE80, M0 to M11 1ss – Antenna A



6385 MHz: HE80, M0 to M11 1ss – Antenna A

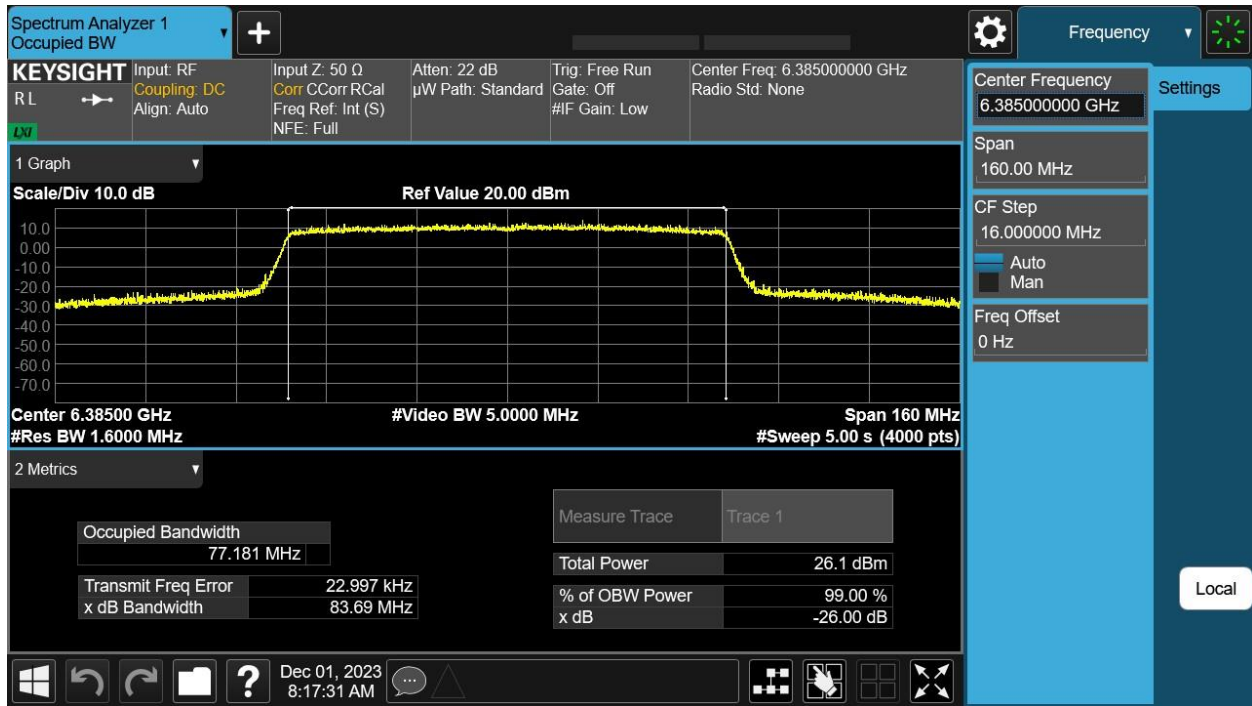

6025 MHz: HE160, M0 to M11 1ss - Antenna A

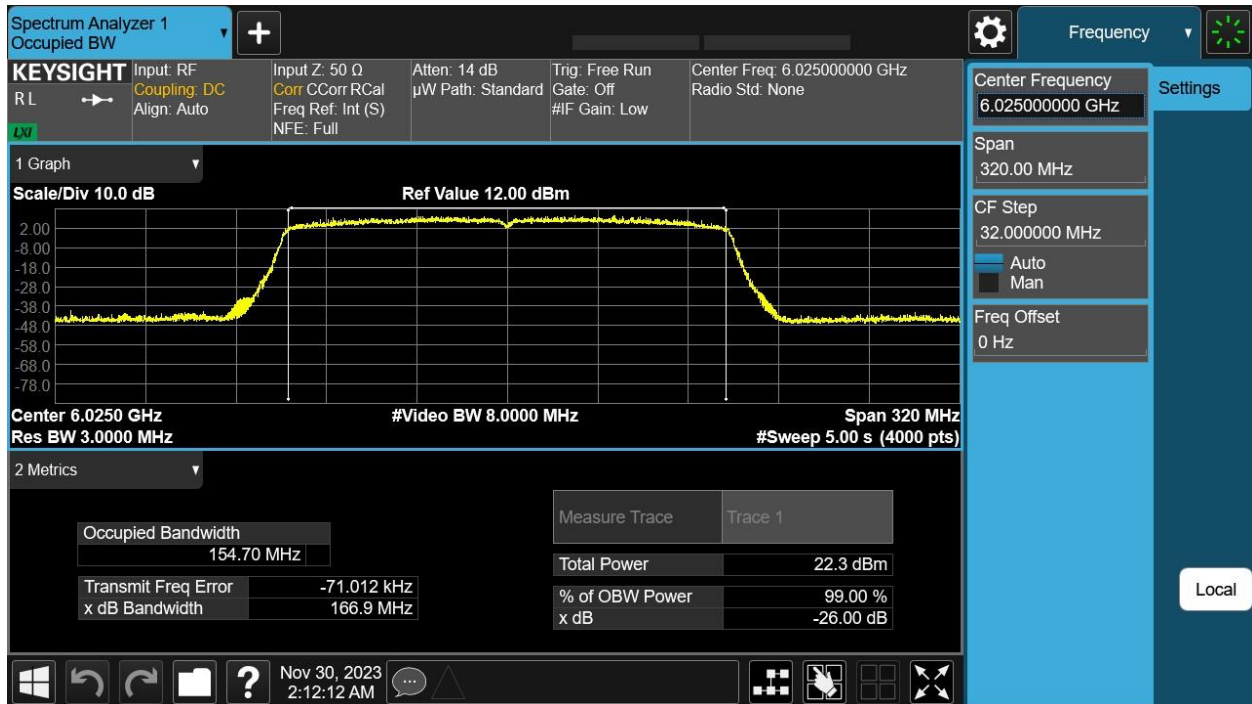

6185 MHz: HE160, M0 to M11 1ss - Antenna A

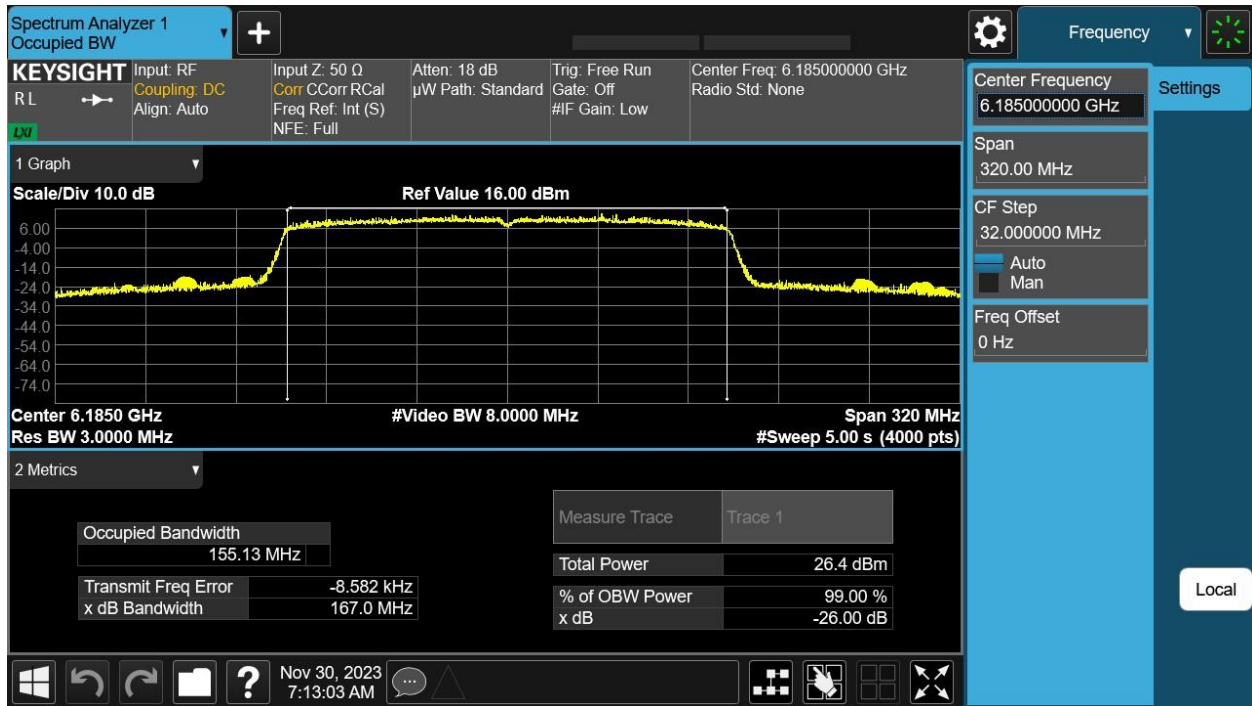

6345 MHz: HE160, M0 to M11 1ss - Antenna A

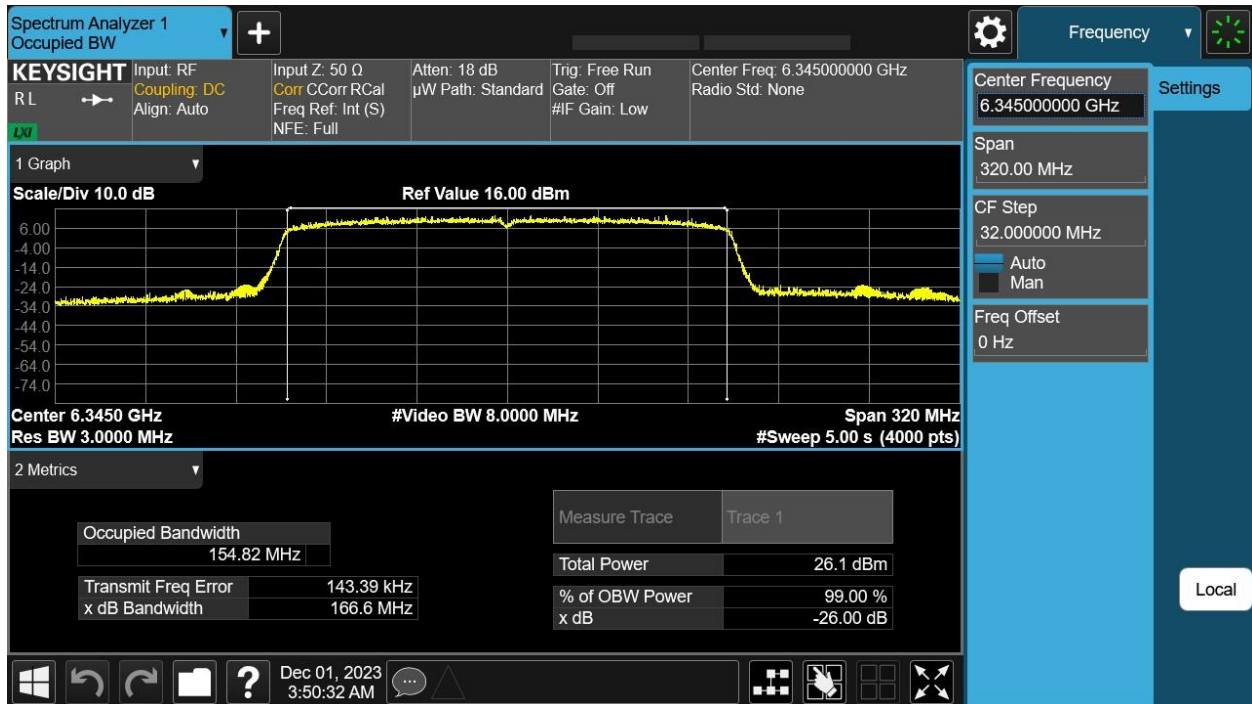

A.3: Maximum Conducted Output Power

Maximum Conducted Output Power Test Requirement

15.407 General technical requirements, (a) Power limits: (4) For the bands 5.925–6.425 GHz and 6.525–6.875 GHz bands.

For a standard power access point and fixed client device operating in the 5.925–6.425 GHz and 6.525–6.875 GHz bands, the maximum power spectral density must not exceed 23 dBm e.i.r.p in any 1-megahertz band. In addition, the maximum e.i.r.p. over the frequency band of operation must not exceed 36 dBm. For outdoor devices, the maximum e.i.r.p. at any elevation angle above 30 degrees as measured from the horizon must not exceed 125 mW (21 dBm).

Maximum Conducted Output Power Test Procedure

987594 D02 U-NII 6 GHz EMC Measurement v02r01 Clause II (E).

Ref. KDB 789033 D02 General UNII Test Procedures New Rules v02r01 ANSI C63.10: 2013

Maximum Conducted Output Power Test Procedure
1. Set the radio in the continuous transmitting mode at full power 2. Compute power by integrating the spectrum across the EBW (or alternatively entire 99% OBW) of the signal using the instrument's band power measurement function. The integration shall be performed using the spectrum analyzer band-power measurement function with band limits set equal to the EBW or the OBW band edges. 3. Capture graphs and record pertinent measurement data.

Ref. KDB 789033 D02 General UNII Test Procedures New Rules v02r01

2. Measurement using a Spectrum Analyzer or EMI Receiver (SA), (d) Method SA-2

Maximum Conducted Output Power Test parameters
Method SA-2 (trace averaging across on and off times of the EUT transmissions, followed by duty cycle correction). (i) Measure the duty cycle, x , of the transmitter output signal as described in section II.B. (ii) Set span to encompass the EBW (or, alternatively, the entire 99% occupied bandwidth) of the signal. (iii) Set RBW = 1 MHz. (iv) Set VBW \geq 3 MHz. (v) Number of points in sweep \geq 2 Span / RBW. (This ensures that bin-to-bin spacing is \leq RBW/2, so that narrowband signals are not lost between frequency bins.) (vi) Sweep time = auto. (vii) Detector = RMS (i.e., power averaging), if available. Otherwise, use sample detector mode. (viii) Do not use sweep triggering. Allow the sweep to "free run". (ix) Trace average at least 100 traces in power averaging (i.e., RMS) mode; however, the number of traces to be averaged shall be increased above 100 as needed to ensure that the average accurately represents the true average over the on and off periods of the transmitter. (x) Compute power by integrating the spectrum across the EBW (or, alternatively, the entire 99% occupied bandwidth) of the signal using the instrument's band power measurement function with band limits set equal to the EBW (or occupied bandwidth)

The "measure-and-sum technique" is used for measuring in-band transmit power of a device. In the measure-and-sum approach, the conducted emission level is measured at each antenna port. The measured results at the various antenna ports are then summed mathematically to determine the total emission level from the device. Summing is performed in linear power units. ANSI C63.10 section 14.3.2.2

Tested By: Ronak Patel	Date of testing: 11/28/2023 – 12/01/2023
Test Result: PASS	

Test Equipment

See Appendix C for list of test equipment.

Maximum EIRP – Antenna gain 7dBi – 20MHz.
5955 MHz

Mode	Tx Paths	Correlated Antenna Gain (dBi)	Tx 1 Max Power (dBm)	Tx 2 Max Power (dBm)	Duty Cycle (dB)	Total Channel Power (dBm)	Limit (dBm)	Margin (dB)
HE20, M0 to M11 1ss	1	7.00	15.60		0.12	22.69	36.00	13.31
HE20, M0 to M11 1ss	2	7.00	15.60	15.70	0.12	25.75	36.00	10.25
HE20, M0 to M11 2ss	2	7.00	15.60	15.70	0.12	25.75	36.00	10.25
HE20 Beam Forming, M0 to M11 1ss	2	10.00	14.40	14.40	0.12	27.54	36.00	8.46
HE20 Beam Forming, M0 to M11 2ss	2	7.00	15.60	15.70	0.12	25.75	36.00	10.25
HE20 STBC, M0 to M11 2ss	2	7.00	15.60	15.70	0.12	25.75	36.00	10.25

6175 MHz

Mode	Tx Paths	Correlated Antenna Gain (dBi)	Tx 1 Max Power (dBm)	Tx 2 Max Power (dBm)	Duty Cycle (dB)	Total Channel Power (dBm)	Limit (dBm)	Margin (dB)
HE20, M0 to M11 1ss	1	7.00	16.00		0.12	23.08	36.00	12.92
HE20, M0 to M11 1ss	2	7.00	16.00	16.20	0.12	26.21	36.00	9.79
HE20, M0 to M11 2ss	2	7.00	16.00	16.20	0.12	26.21	36.00	9.79
HE20 Beam Forming, M0 to M11 1ss	2	10.00	16.00	16.20	0.12	29.21	36.00	6.79
HE20 Beam Forming, M0 to M11 2ss	2	7.00	16.00	16.20	0.12	26.21	36.00	9.79
HE20 STBC, M0 to M11 2ss	2	7.00	16.00	16.20	0.12	26.21	36.00	9.79

6415 MHz

Mode	Tx Paths	Correlated Antenna Gain (dBi)	Tx 1 Max Power (dBm)	Tx 2 Max Power (dBm)	Duty Cycle (dB)	Total Channel Power (dBm)	Limit (dBm)	Margin (dB)
HE20, M0 to M11 1ss	1	7.00	16.10		0.12	23.18	36.00	12.82
HE20, M0 to M11 1ss	2	7.00	16.10	16.20	0.12	26.25	36.00	9.75
HE20, M0 to M11 2ss	2	7.00	16.10	16.20	0.12	26.25	36.00	9.75
HE20 Beam Forming, M0 to M11 1ss	2	10.00	16.10	16.20	0.12	29.25	36.00	6.75
HE20 Beam Forming, M0 to M11 2ss	2	7.00	16.10	16.20	0.12	26.25	36.00	9.75
HE20 STBC, M0 to M11 2ss	2	7.00	16.10	16.20	0.12	26.25	36.00	9.75

Maximum EIRP – Antenna gain 7dBi – 40MHz.
5965 MHz

Mode	Tx Paths	Correlated Antenna Gain (dBi)	Tx 1 Max Power (dBm)	Tx 2 Max Power (dBm)	Duty Cycle (dB)	Total Channel Power (dBm)	Limit (dBm)	Margin (dB)
HE40, M0 to M11 1ss	1	7.00	14.70		0.19	21.85	36.00	14.15
HE40, M0 to M11 1ss	2	7.00	13.50	13.60	0.19	23.80	36.00	12.20
HE40, M0 to M11 2ss	2	7.00	13.50	13.60	0.19	23.80	36.00	12.20
HE40 Beam Forming, M0 to M11 1ss	2	10.00	12.40	12.60	0.19	25.70	36.00	10.30
HE40 Beam Forming, M0 to M11 2ss	2	7.00	13.50	13.60	0.19	23.80	36.00	12.20
HE40 STBC, M0 to M11 2ss	2	7.00	13.50	13.60	0.19	23.80	36.00	12.20

6205 MHz

Mode	Tx Paths	Correlated Antenna Gain (dBi)	Tx 1 Max Power (dBm)	Tx 2 Max Power (dBm)	Duty Cycle (dB)	Total Channel Power (dBm)	Limit (dBm)	Margin (dB)
HE40, M0 to M11 1ss	1	7.00	16.00		0.19	23.23	36.00	12.77
HE40, M0 to M11 1ss	2	7.00	16.00	16.20	0.19	26.30	36.00	9.70
HE40, M0 to M11 2ss	2	7.00	16.00	16.20	0.19	26.30	36.00	9.70
HE40 Beam Forming, M0 to M11 1ss	2	10.00	16.00	16.20	0.19	29.30	36.00	6.70
HE40 Beam Forming, M0 to M11 2ss	2	7.00	16.00	16.20	0.19	26.30	36.00	9.70
HE40 STBC, M0 to M11 2ss	2	7.00	16.00	16.20	0.19	26.30	36.00	9.70

6405 MHz

Mode	Tx Paths	Correlated Antenna Gain (dBi)	Tx 1 Max Power (dBm)	Tx 2 Max Power (dBm)	Duty Cycle (dB)	Total Channel Power (dBm)	Limit (dBm)	Margin (dB)
HE40, M0 to M11 1ss	1	7.00	16.30		0.19	23.54	36.00	12.46
HE40, M0 to M11 1ss	2	7.00	16.30	16.40	0.19	26.57	36.00	9.43
HE40, M0 to M11 2ss	2	7.00	16.30	16.40	0.19	26.57	36.00	9.43
HE40 Beam Forming, M0 to M11 1ss	2	10.00	16.30	16.40	0.19	29.57	36.00	6.43
HE40 Beam Forming, M0 to M11 2ss	2	7.00	16.30	16.40	0.19	26.57	36.00	9.43
HE40 STBC, M0 to M11 2ss	2	7.00	16.30	16.40	0.19	26.57	36.00	9.43

Maximum EIRP – Antenna gain 7dBi – 80MHz.
 5985 MHz

Mode	Tx Paths	Correlated Antenna Gain (dBi)	Tx 1 Max Power (dBm)	Tx 2 Max Power (dBm)	Duty Cycle (dB)	Total Channel Power (dBm)	Limit (dBm)	Margin (dB)
HE80, M0 to M11 1ss	1	7.00	13.50		0.25	20.78	36.00	15.22
HE80, M0 to M11 1ss	2	7.00	13.50	13.70	0.25	23.87	36.00	12.13
HE80, M0 to M11 2ss	2	7.00	13.50	13.70	0.25	23.87	36.00	12.13
HE80 Beam Forming, M0 to M11 1ss	2	10.00	12.40	12.70	0.25	25.81	36.00	10.19
HE80 Beam Forming, M0 to M11 2ss	2	7.00	13.50	13.70	0.25	23.87	36.00	12.13
HE80 STBC, M0 to M11 2ss	2	7.00	13.50	13.70	0.25	23.87	36.00	12.13

6225 MHz

Mode	Tx Paths	Correlated Antenna Gain (dBi)	Tx 1 Max Power (dBm)	Tx 2 Max Power (dBm)	Duty Cycle (dB)	Total Channel Power (dBm)	Limit (dBm)	Margin (dB)
HE80, M0 to M11 1ss	1	7.00	16.20		0.25	23.49	36.00	12.51
HE80, M0 to M11 1ss	2	7.00	16.20	16.40	0.25	26.56	36.00	9.44
HE80, M0 to M11 2ss	2	7.00	16.20	16.40	0.25	26.56	36.00	9.44
HE80 Beam Forming, M0 to M11 1ss	2	10.00	16.20	16.40	0.25	29.56	36.00	6.44
HE80 Beam Forming, M0 to M11 2ss	2	7.00	16.20	16.40	0.25	26.56	36.00	9.44
HE80 STBC, M0 to M11 2ss	2	7.00	16.20	16.40	0.25	26.56	36.00	9.44

6385 MHz

Mode	Tx Paths	Correlated Antenna Gain (dBi)	Tx 1 Max Power (dBm)	Tx 2 Max Power (dBm)	Duty Cycle (dB)	Total Channel Power (dBm)	Limit (dBm)	Margin (dB)
HE80, M0 to M11 1ss	1	7.00	16.30		0.25	23.55	36.00	12.45
HE80, M0 to M11 1ss	2	7.00	16.30	16.40	0.25	26.62	36.00	9.38
HE80, M0 to M11 2ss	2	7.00	16.30	16.40	0.25	26.62	36.00	9.38
HE80 Beam Forming, M0 to M11 1ss	2	10.00	16.30	16.40	0.25	29.62	36.00	6.38
HE80 Beam Forming, M0 to M11 2ss	2	7.00	16.30	16.40	0.25	26.62	36.00	9.38
HE80 STBC, M0 to M11 2ss	2	7.00	16.30	16.40	0.25	26.62	36.00	9.38

Maximum EIRP – Antenna gain 7dBi – 160MHz.
6025 MHz

Mode	Tx Paths	Correlated Antenna Gain (dBi)	Tx 1 Max Power (dBm)	Tx 2 Max Power (dBm)	Duty Cycle (dB)	Total Channel Power (dBm)	Limit (dBm)	Margin (dB)
HE160, M0 to M11 1ss	1	7.00	14.50		0.32	21.80	36.00	14.20
HE160, M0 to M11 1ss	2	7.00	14.50	14.40	0.32	24.79	36.00	11.21
HE160, M0 to M11 2ss	2	7.00	14.50	14.40	0.32	24.79	36.00	11.21
HE160 Beam Forming, M0 to M11 1ss	2	10.00	12.30	12.30	0.32	25.64	36.00	10.36
HE160 Beam Forming, M0 to M11 2ss	2	7.00	14.50	14.40	0.32	24.79	36.00	11.21
HE160 STBC, M0 to M11 2ss	2	7.00	14.50	14.40	0.32	24.79	36.00	11.21

6185 MHz

Mode	Tx Paths	Correlated Antenna Gain (dBi)	Tx 1 Max Power (dBm)	Tx 2 Max Power (dBm)	Duty Cycle (dB)	Total Channel Power (dBm)	Limit (dBm)	Margin (dB)
HE160, M0 to M11 1ss	1	7.00	16.30		0.32	23.64	36.00	12.36
HE160, M0 to M11 1ss	2	7.00	16.30	16.60	0.32	26.78	36.00	9.22
HE160, M0 to M11 2ss	2	7.00	16.30	16.60	0.32	26.78	36.00	9.22
HE160 Beam Forming, M0 to M11 1ss	2	10.00	16.30	16.60	0.32	29.78	36.00	6.22
HE160 Beam Forming, M0 to M11 2ss	2	7.00	16.30	16.60	0.32	26.78	36.00	9.22
HE160 STBC, M0 to M11 2ss	2	7.00	16.30	16.60	0.32	26.78	36.00	9.22

6345 MHz

Mode	Tx Paths	Correlated Antenna Gain (dBi)	Tx 1 Max Power (dBm)	Tx 2 Max Power (dBm)	Duty Cycle (dB)	Total Channel Power (dBm)	Limit (dBm)	Margin (dB)
HE160, M0 to M11 1ss	1	7.00	16.20		0.32	23.53	36.00	12.47
HE160, M0 to M11 1ss	2	7.00	16.20	16.40	0.32	26.64	36.00	9.36
HE160, M0 to M11 2ss	2	7.00	16.20	16.40	0.32	26.64	36.00	9.36
HE160 Beam Forming, M0 to M11 1ss	2	10.00	16.20	16.40	0.32	29.64	36.00	6.36
HE160 Beam Forming, M0 to M11 2ss	2	7.00	16.20	16.40	0.32	26.64	36.00	9.36
HE160 STBC, M0 to M11 2ss	2	7.00	16.20	16.40	0.32	26.64	36.00	9.36

Data Screenshots – Antenna gain 7dBi – 20MHz.

6175 MHz: HE20 Beam Forming, M0 to M11 1ss – Antenna A

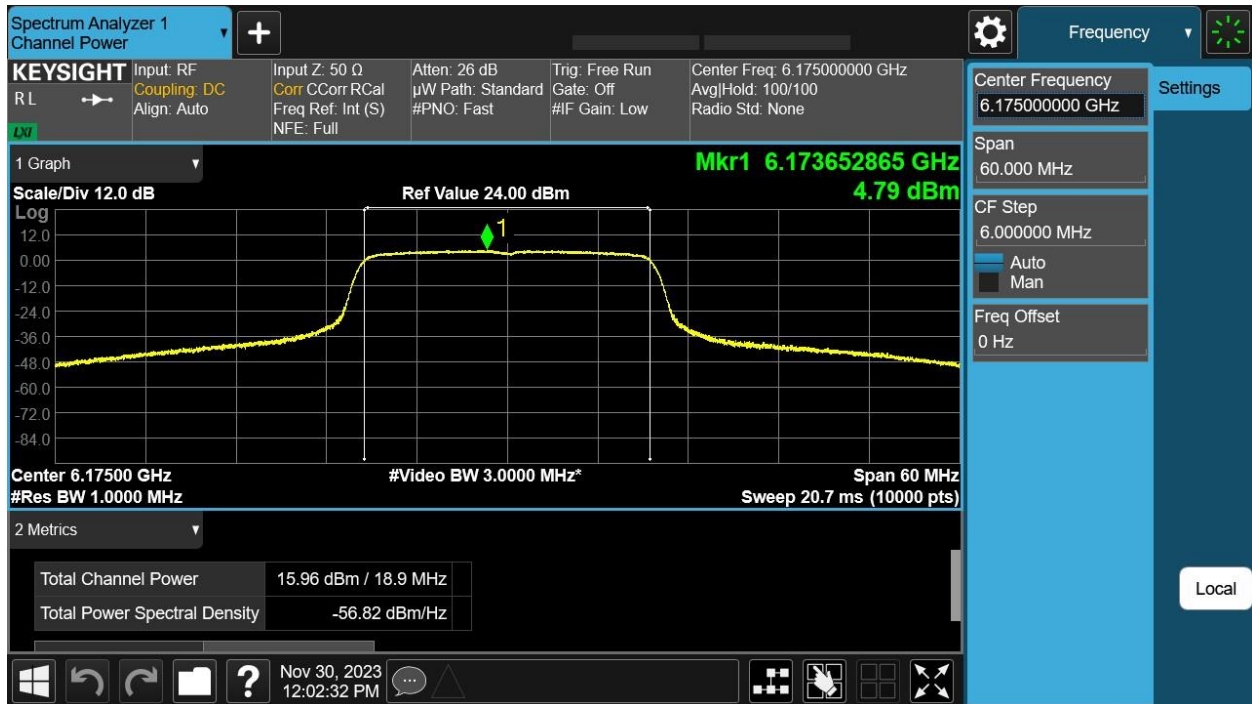

6175 MHz: HE20 Beam Forming, M0 to M11 1ss – Antenna B

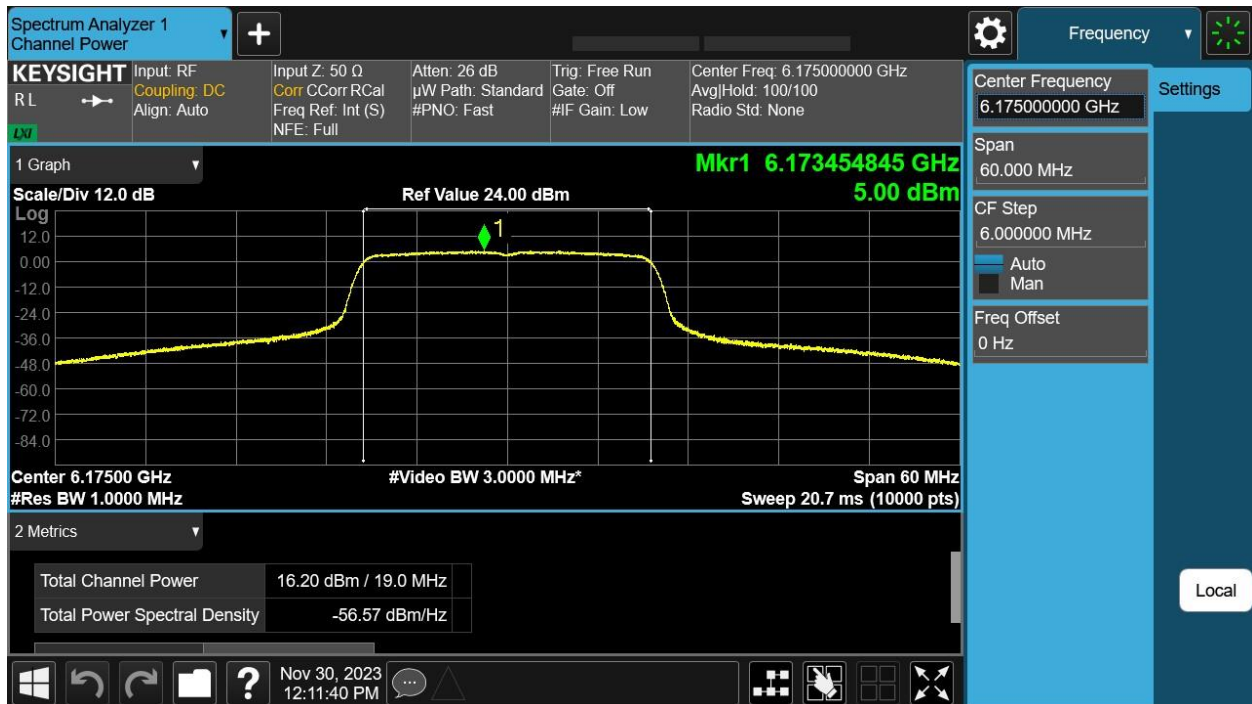

6415 MHz: HE20 Beam Forming, M0 to M11 1ss – Antenna A

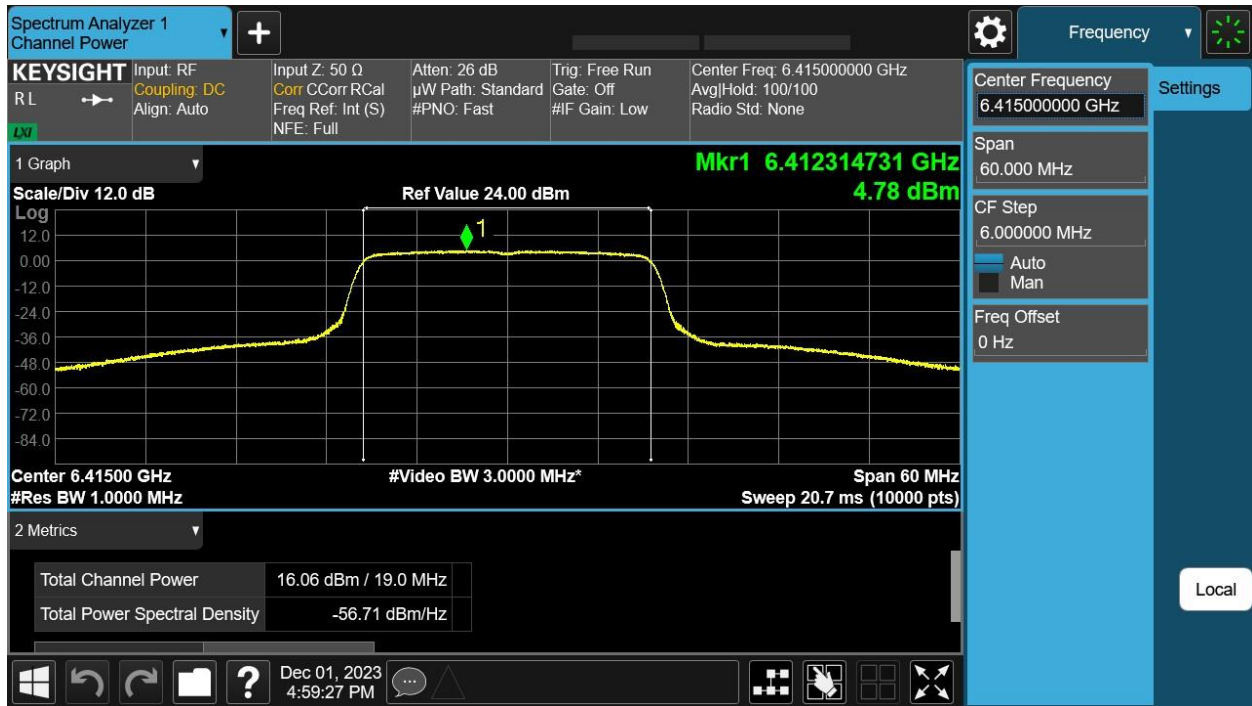

6415 MHz: HE20 Beam Forming, M0 to M11 1ss – Antenna B

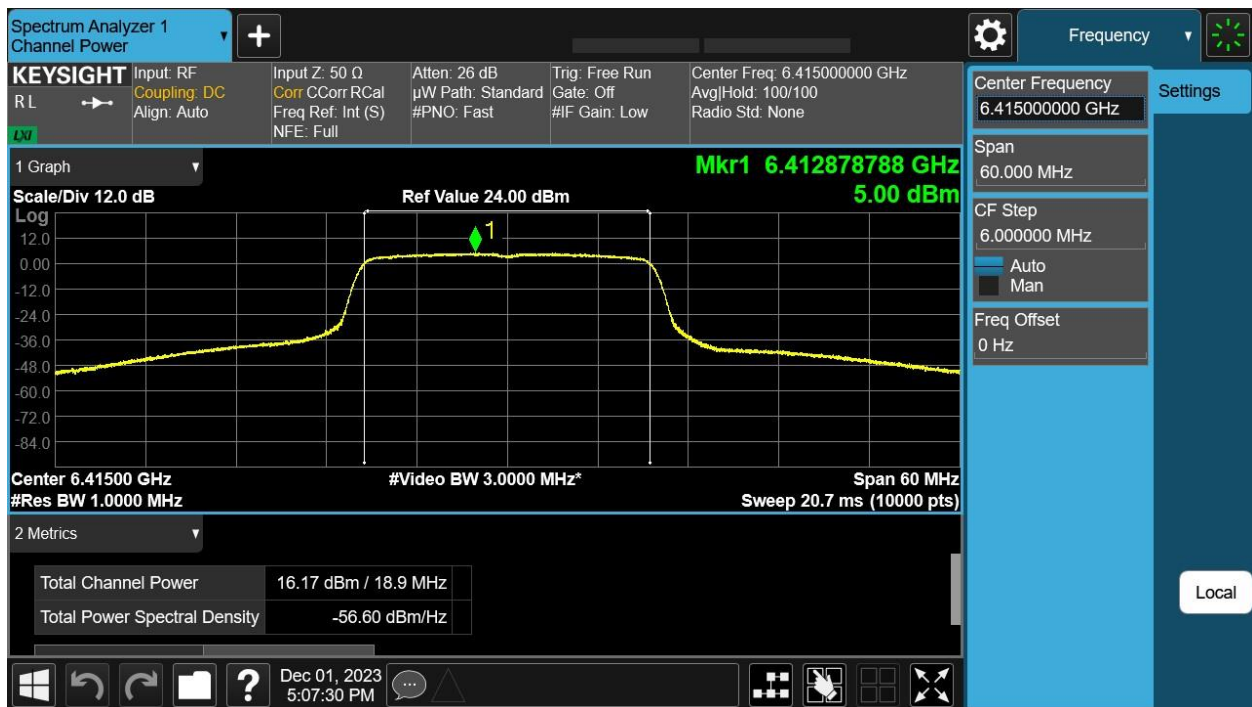

Data Screenshots – Antenna gain 7dBi – 40MHz.

6205 MHz: HE40 Beam Forming, M0 to M11 1ss – Antenna A

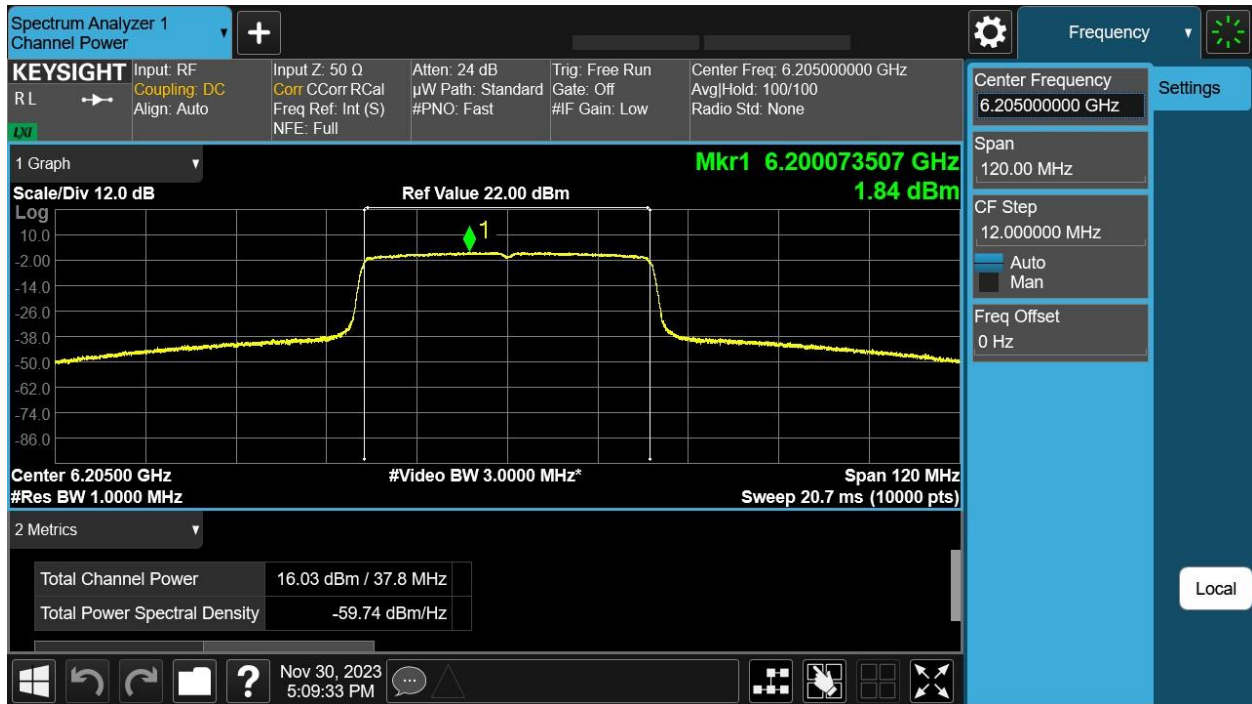

6205 MHz: HE40 Beam Forming, M0 to M11 1ss – Antenna B

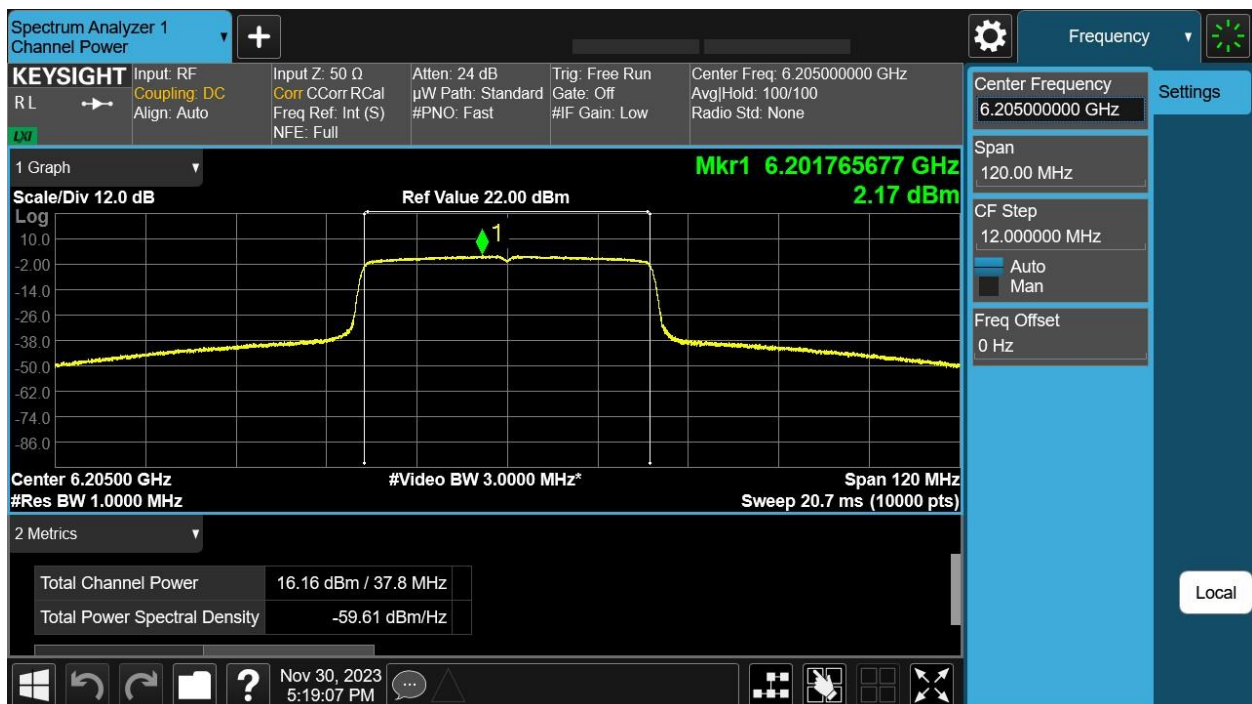

6405 MHz: HE40 Beam Forming, M0 to M11 1ss – Antenna A

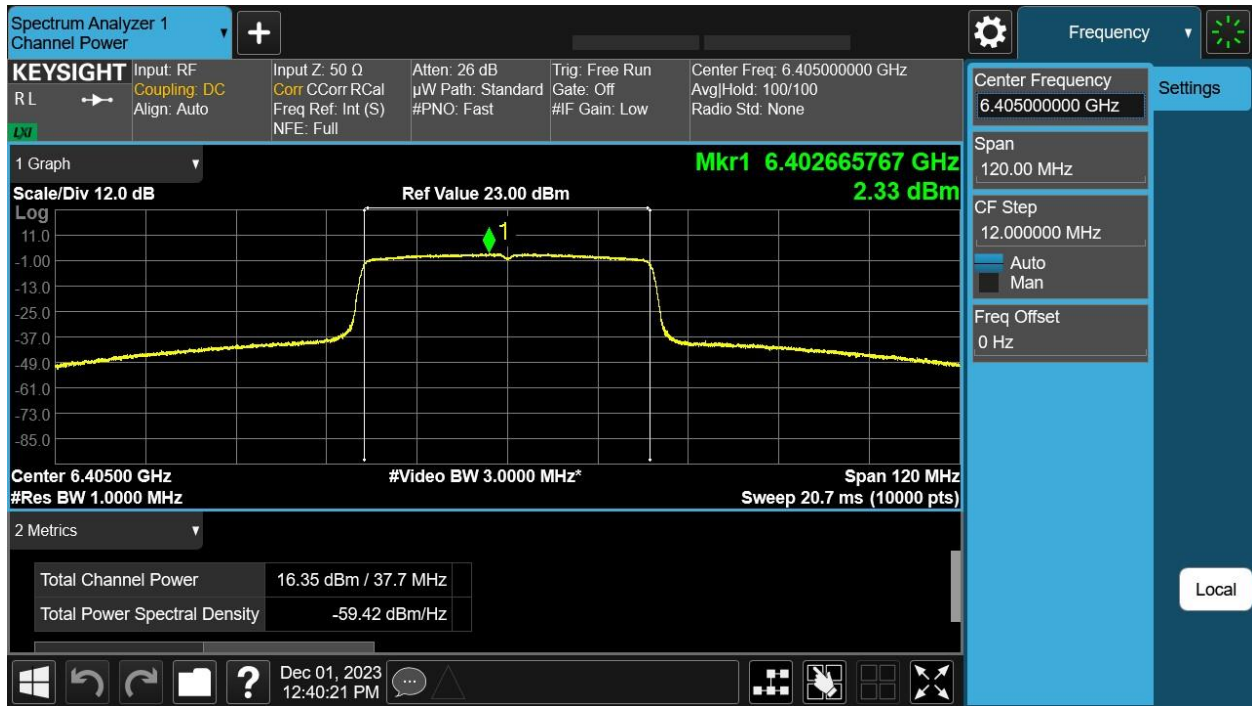

6405 MHz: HE40 Beam Forming, M0 to M11 1ss – Antenna B

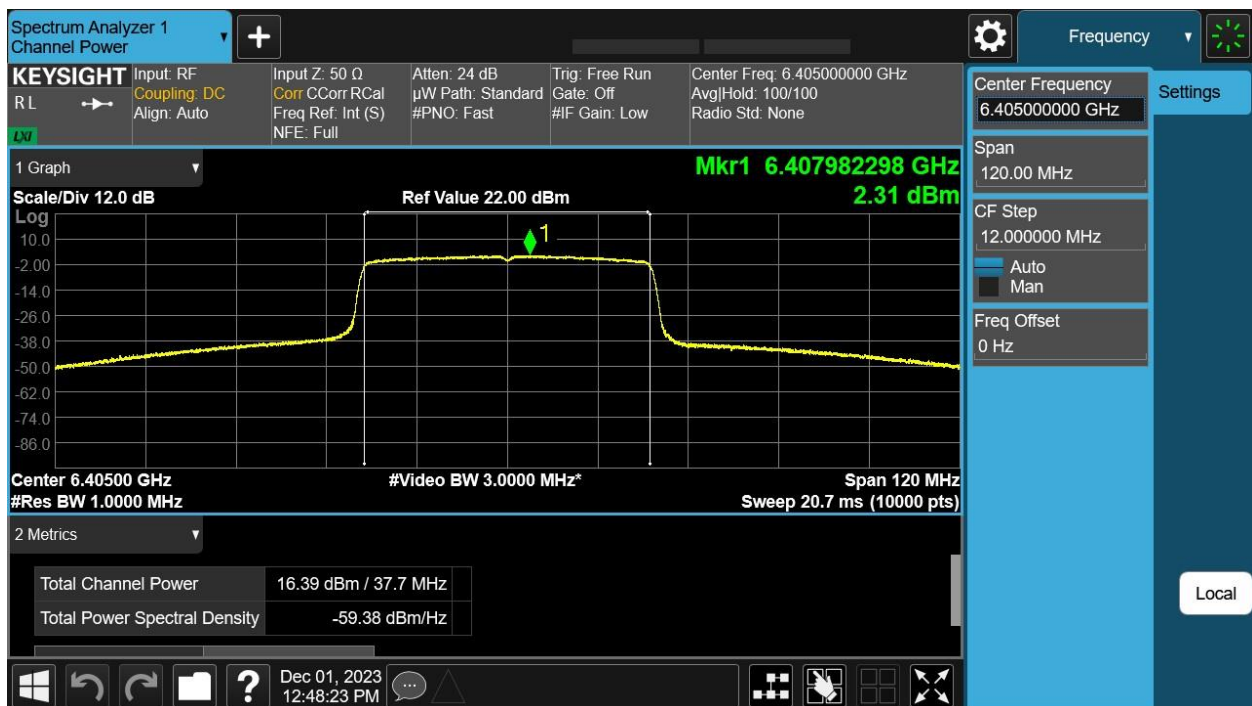

Data Screenshots – Antenna gain 7dBi – 80MHz.

6225 MHz: HE80 Beam Forming, M0 to M11 1ss – Antenna A

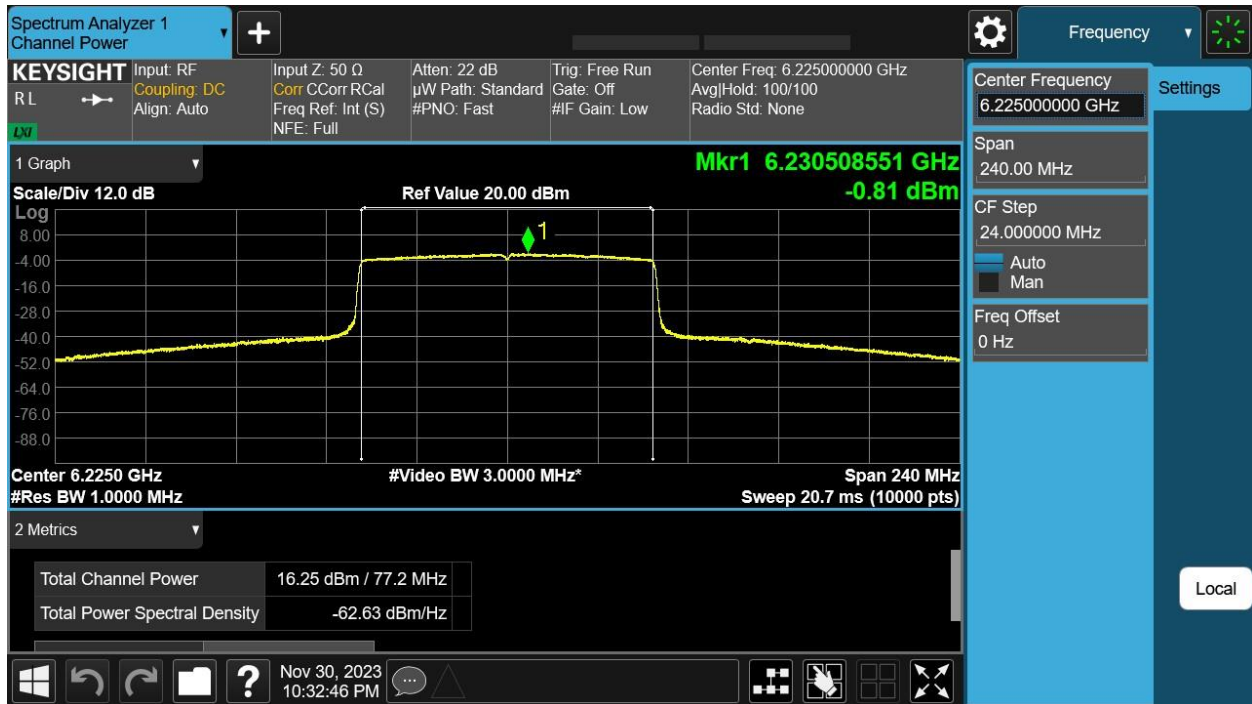

6225 MHz: HE80 Beam Forming, M0 to M11 1ss – Antenna B

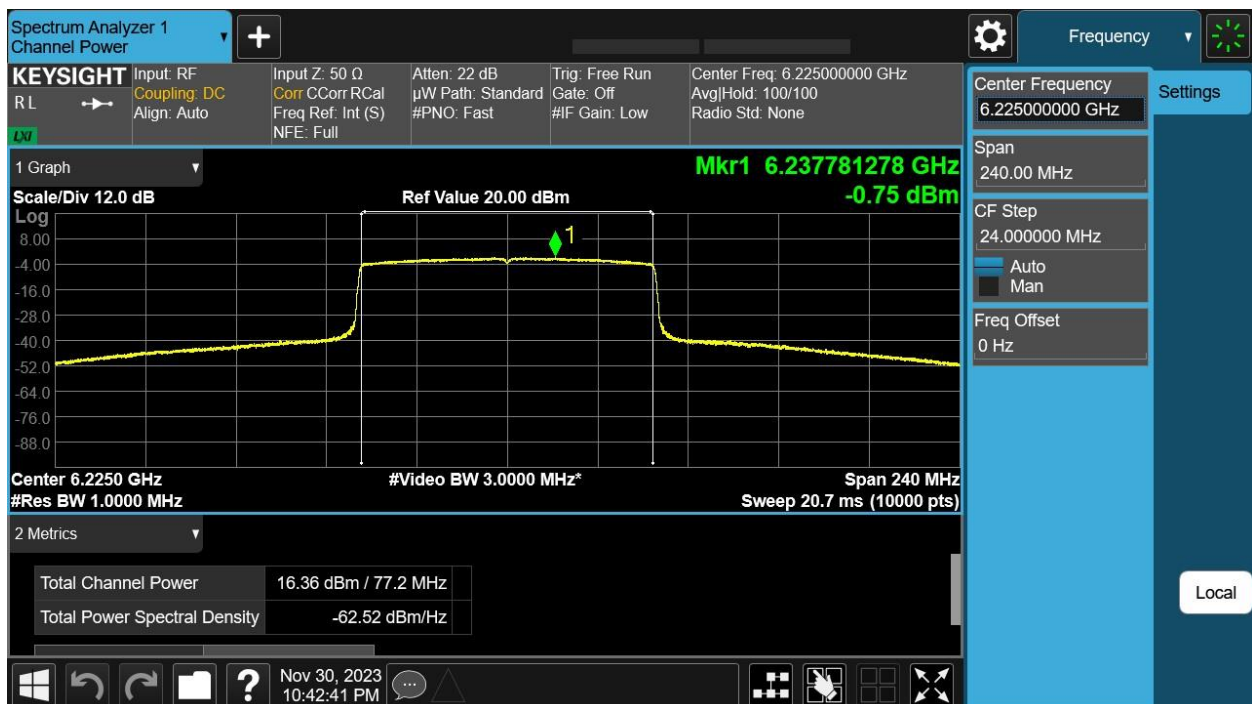

6385 MHz: HE80 Beam Forming, M0 to M11 1ss – Antenna A

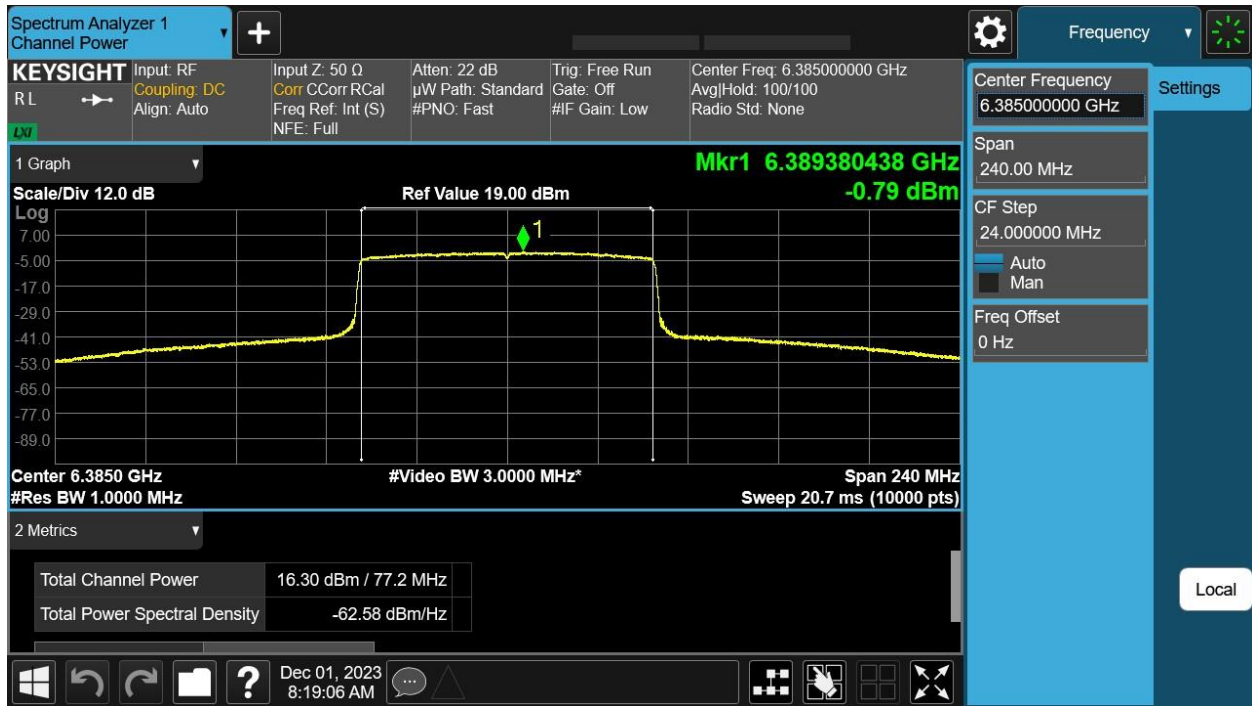

6385 MHz: HE80 Beam Forming, M0 to M11 1ss – Antenna B

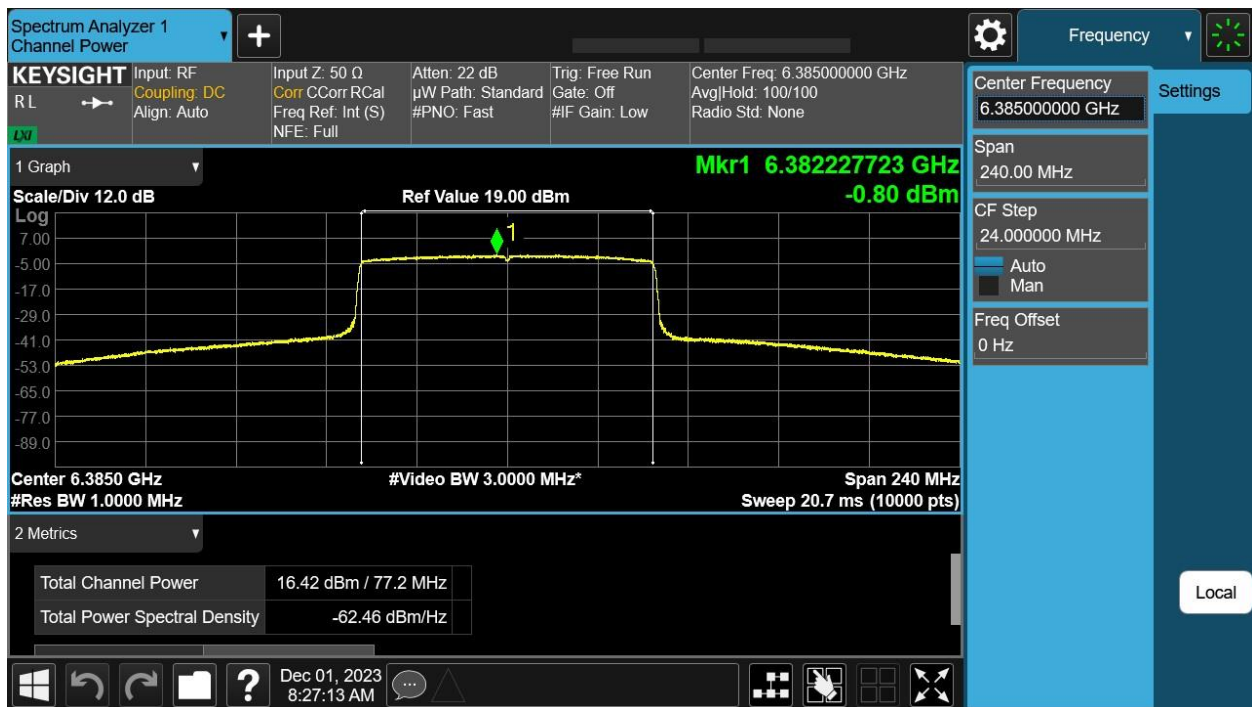

Data Screenshots – Antenna gain 7dBi – 160MHz.

6185 MHz: HE160 Beam Forming, M0 to M11 1ss – Antenna A

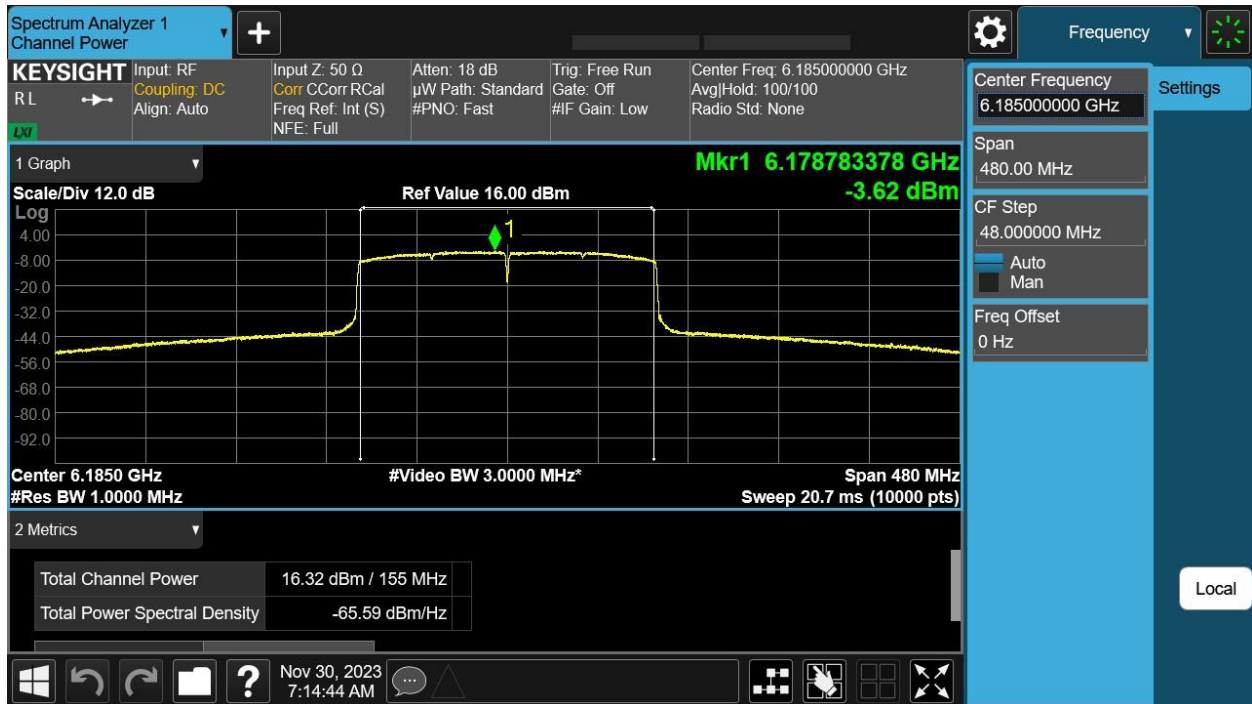

6185 MHz: HE160 Beam Forming, M0 to M11 1ss – Antenna B

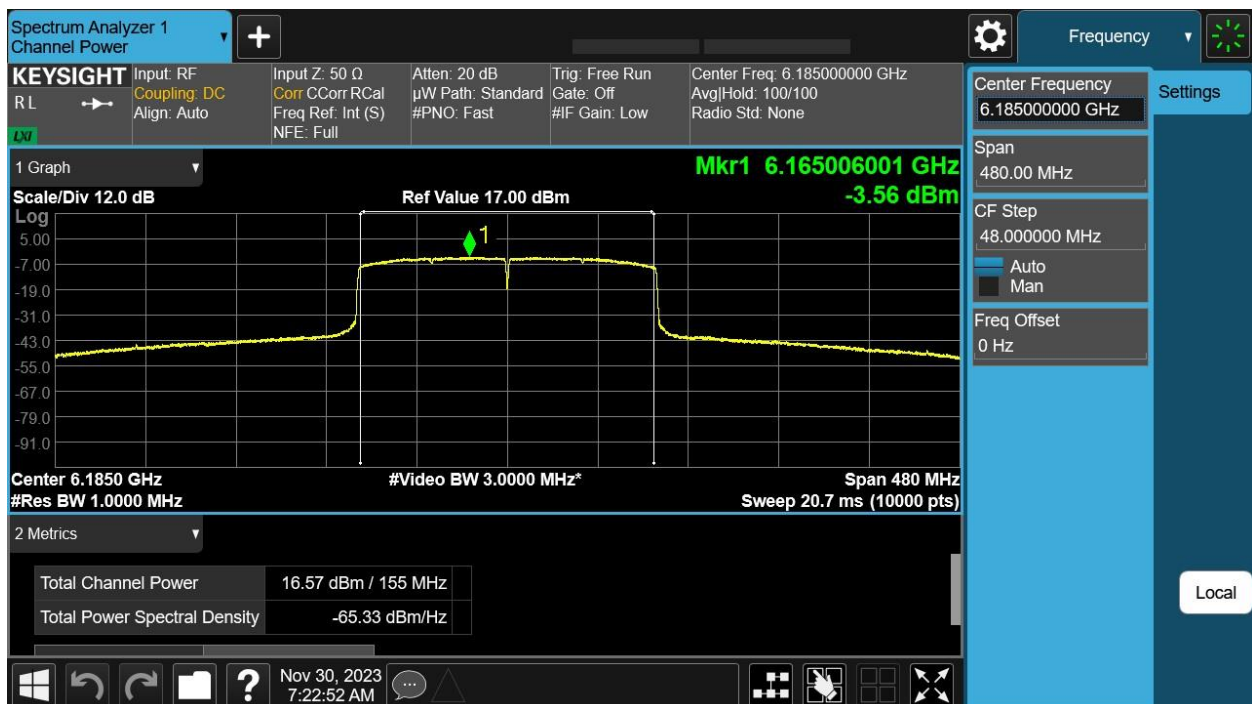

6345 MHz: HE160 Beam Forming, M0 to M11 1ss – Antenna A

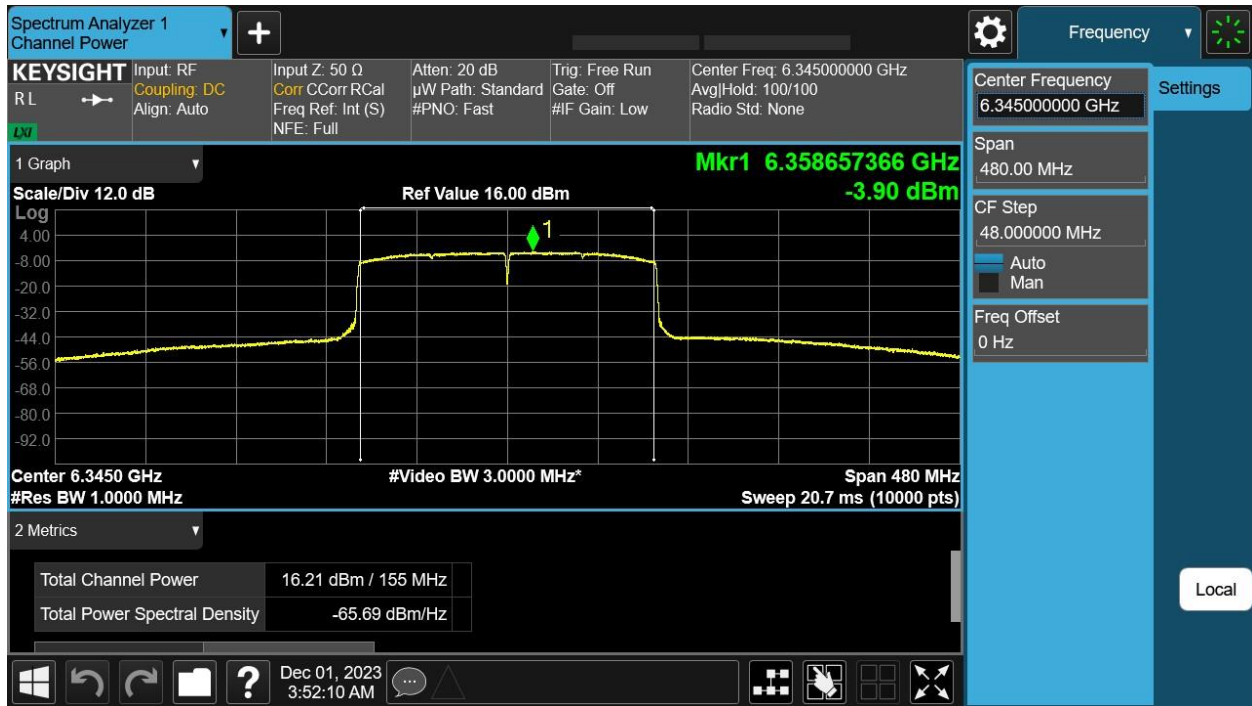

6345 MHz: HE160 Beam Forming, M0 to M11 1ss – Antenna B

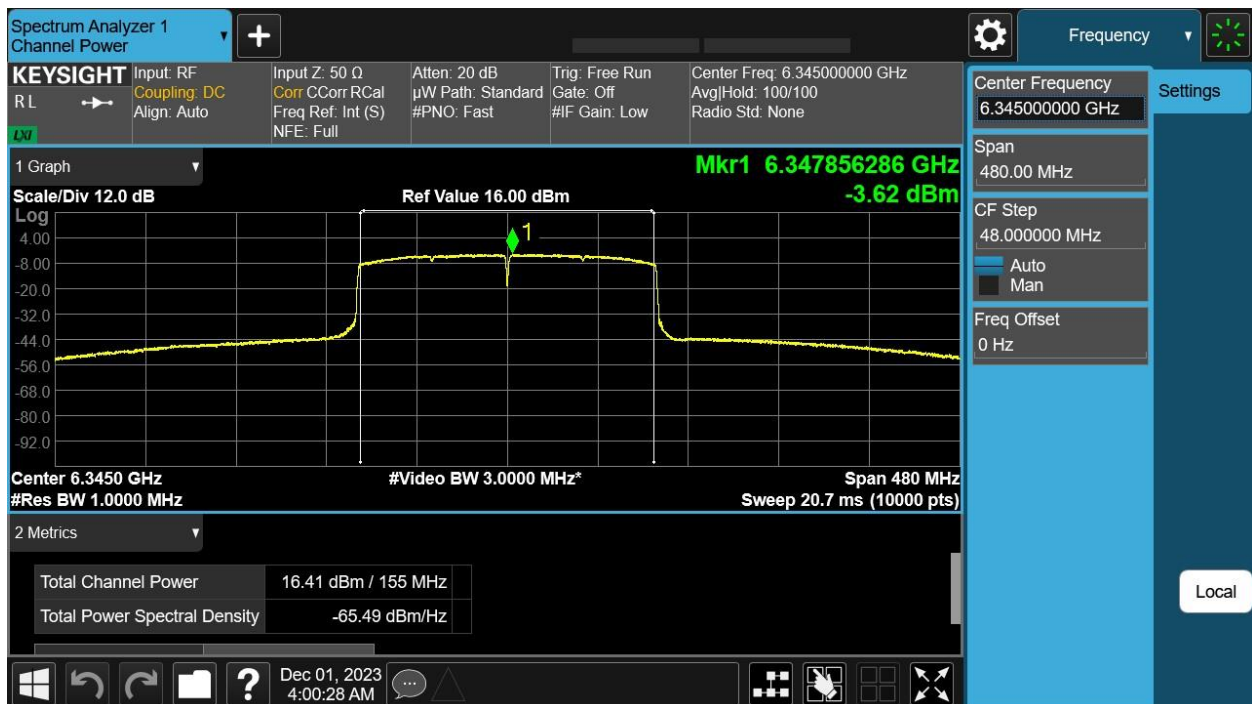

Maximum Transmit Power > 30° - Antenna gain 7dBi (-4dBi) – 20MHz.

5955 MHz

Mode	Tx Paths	Correlated Antenna Gain (dBi)	Tx 1 Max Power (dBm)	Tx 2 Max Power (dBm)	Duty Cycle (dB)	Total Channel Power (dBm)	Limit (dBm)	Margin (dB)
HE20, M0 to M11 1ss	1	-4.00	15.60		0.12	11.69	21.00	9.31
HE20, M0 to M11 1ss	2	-4.00	15.60	15.70	0.12	14.75	21.00	6.25
HE20, M0 to M11 2ss	2	-4.00	15.60	15.70	0.12	14.75	21.00	6.25
HE20 Beam Forming, M0 to M11 1ss	2	-1.00	14.40	14.40	0.12	16.54	21.00	4.46
HE20 Beam Forming, M0 to M11 2ss	2	-4.00	15.60	15.70	0.12	14.75	21.00	6.25
HE20 STBC, M0 to M11 2ss	2	-4.00	15.60	15.70	0.12	14.75	21.00	6.25

6175 MHz

Mode	Tx Paths	Correlated Antenna Gain (dBi)	Tx 1 Max Power (dBm)	Tx 2 Max Power (dBm)	Duty Cycle (dB)	Total Channel Power (dBm)	Limit (dBm)	Margin (dB)
HE20, M0 to M11 1ss	1	-4.00	16.00		0.12	12.08	21.00	8.92
HE20, M0 to M11 1ss	2	-4.00	16.00	16.20	0.12	15.21	21.00	5.79
HE20, M0 to M11 2ss	2	-4.00	16.00	16.20	0.12	15.21	21.00	5.79
HE20 Beam Forming, M0 to M11 1ss	2	-1.00	16.00	16.20	0.12	18.21	21.00	2.79
HE20 Beam Forming, M0 to M11 2ss	2	-4.00	16.00	16.20	0.12	15.21	21.00	5.79
HE20 STBC, M0 to M11 2ss	2	-4.00	16.00	16.20	0.12	15.21	21.00	5.79

6415 MHz

Mode	Tx Paths	Correlated Antenna Gain (dBi)	Tx 1 Max Power (dBm)	Tx 2 Max Power (dBm)	Duty Cycle (dB)	Total Channel Power (dBm)	Limit (dBm)	Margin (dB)
HE20, M0 to M11 1ss	1	-4.00	16.10		0.12	12.18	21.00	8.82
HE20, M0 to M11 1ss	2	-4.00	16.10	16.20	0.12	15.25	21.00	5.75
HE20, M0 to M11 2ss	2	-4.00	16.10	16.20	0.12	15.25	21.00	5.75
HE20 Beam Forming, M0 to M11 1ss	2	-1.00	16.10	16.20	0.12	18.25	21.00	2.75
HE20 Beam Forming, M0 to M11 2ss	2	-4.00	16.10	16.20	0.12	15.25	21.00	5.75
HE20 STBC, M0 to M11 2ss	2	-4.00	16.10	16.20	0.12	15.25	21.00	5.75

Maximum Transmit Power > 30° - Antenna gain 7dBi (-4dBi) – 40MHz.

5965 MHz

Mode	Tx Paths	Correlated Antenna Gain (dBi)	Tx 1 Max Power (dBm)	Tx 2 Max Power (dBm)	Duty Cycle (dB)	Total Channel Power (dBm)	Limit (dBm)	Margin (dB)
HE40, M0 to M11 1ss	1	-4.00	14.70		0.19	10.85	21.00	10.15
HE40, M0 to M11 1ss	2	-4.00	13.50	13.60	0.19	12.80	21.00	8.20
HE40, M0 to M11 2ss	2	-4.00	13.50	13.60	0.19	12.80	21.00	8.20
HE40 Beam Forming, M0 to M11 1ss	2	-1.00	12.40	12.60	0.19	14.70	21.00	6.30
HE40 Beam Forming, M0 to M11 2ss	2	-4.00	13.50	13.60	0.19	12.80	21.00	8.20
HE40 STBC, M0 to M11 2ss	2	-4.00	13.50	13.60	0.19	12.80	21.00	8.20

6205 MHz

Mode	Tx Paths	Correlated Antenna Gain (dBi)	Tx 1 Max Power (dBm)	Tx 2 Max Power (dBm)	Duty Cycle (dB)	Total Channel Power (dBm)	Limit (dBm)	Margin (dB)
HE40, M0 to M11 1ss	1	-4.00	16.00		0.19	12.23	21.00	8.77
HE40, M0 to M11 1ss	2	-4.00	16.00	16.20	0.19	15.30	21.00	5.70
HE40, M0 to M11 2ss	2	-4.00	16.00	16.20	0.19	15.30	21.00	5.70
HE40 Beam Forming, M0 to M11 1ss	2	-1.00	16.00	16.20	0.19	18.30	21.00	2.70
HE40 Beam Forming, M0 to M11 2ss	2	-4.00	16.00	16.20	0.19	15.30	21.00	5.70
HE40 STBC, M0 to M11 2ss	2	-4.00	16.00	16.20	0.19	15.30	21.00	5.70

6405 MHz

Mode	Tx Paths	Correlated Antenna Gain (dBi)	Tx 1 Max Power (dBm)	Tx 2 Max Power (dBm)	Duty Cycle (dB)	Total Channel Power (dBm)	Limit (dBm)	Margin (dB)
HE40, M0 to M11 1ss	1	-4.00	16.30		0.19	12.54	21.00	8.46
HE40, M0 to M11 1ss	2	-4.00	16.30	16.40	0.19	15.57	21.00	5.43
HE40, M0 to M11 2ss	2	-4.00	16.30	16.40	0.19	15.57	21.00	5.43
HE40 Beam Forming, M0 to M11 1ss	2	-1.00	16.30	16.40	0.19	18.57	21.00	2.43
HE40 Beam Forming, M0 to M11 2ss	2	-4.00	16.30	16.40	0.19	15.57	21.00	5.43
HE40 STBC, M0 to M11 2ss	2	-4.00	16.30	16.40	0.19	15.57	21.00	5.43

Maximum Transmit Power > 30° - Antenna gain 7dBi (-4dBi) – 80MHz.

5985 MHz

Mode	Tx Paths	Correlated Antenna Gain (dBi)	Tx 1 Max Power (dBm)	Tx 2 Max Power (dBm)	Duty Cycle (dB)	Total Channel Power (dBm)	Limit (dBm)	Margin (dB)
HE80, M0 to M11 1ss	1	-4.00	13.50		0.25	9.78	21.00	11.22
HE80, M0 to M11 1ss	2	-4.00	13.50	13.70	0.25	12.87	21.00	8.13
HE80, M0 to M11 2ss	2	-4.00	13.50	13.70	0.25	12.87	21.00	8.13
HE80 Beam Forming, M0 to M11 1ss	2	-1.00	12.40	12.70	0.25	14.81	21.00	6.19
HE80 Beam Forming, M0 to M11 2ss	2	-4.00	13.50	13.70	0.25	12.87	21.00	8.13
HE80 STBC, M0 to M11 2ss	2	-4.00	13.50	13.70	0.25	12.87	21.00	8.13

6225 MHz

Mode	Tx Paths	Correlated Antenna Gain (dBi)	Tx 1 Max Power (dBm)	Tx 2 Max Power (dBm)	Duty Cycle (dB)	Total Channel Power (dBm)	Limit (dBm)	Margin (dB)
HE80, M0 to M11 1ss	1	-4.00	16.20		0.25	12.49	21.00	8.51
HE80, M0 to M11 1ss	2	-4.00	16.20	16.40	0.25	15.56	21.00	5.44
HE80, M0 to M11 2ss	2	-4.00	16.20	16.40	0.25	15.56	21.00	5.44
HE80 Beam Forming, M0 to M11 1ss	2	-1.00	16.20	16.40	0.25	18.56	21.00	2.44
HE80 Beam Forming, M0 to M11 2ss	2	-4.00	16.20	16.40	0.25	15.56	21.00	5.44
HE80 STBC, M0 to M11 2ss	2	-4.00	16.20	16.40	0.25	15.56	21.00	5.44

6385 MHz

Mode	Tx Paths	Correlated Antenna Gain (dBi)	Tx 1 Max Power (dBm)	Tx 2 Max Power (dBm)	Duty Cycle (dB)	Total Channel Power (dBm)	Limit (dBm)	Margin (dB)
HE80, M0 to M11 1ss	1	-4.00	16.30		0.25	12.55	21.00	8.45
HE80, M0 to M11 1ss	2	-4.00	16.30	16.40	0.25	15.62	21.00	5.38
HE80, M0 to M11 2ss	2	-4.00	16.30	16.40	0.25	15.62	21.00	5.38
HE80 Beam Forming, M0 to M11 1ss	2	-1.00	16.30	16.40	0.25	18.62	21.00	2.38
HE80 Beam Forming, M0 to M11 2ss	2	-4.00	16.30	16.40	0.25	15.62	21.00	5.38
HE80 STBC, M0 to M11 2ss	2	-4.00	16.30	16.40	0.25	15.62	21.00	5.38

Maximum Transmit Power > 30° - Antenna gain 7dBi (-4dBi) – 160MHz.

6025 MHz

Mode	Tx Paths	Correlated Antenna Gain (dBi)	Tx 1 Max Power (dBm)	Tx 2 Max Power (dBm)	Duty Cycle (dB)	Total Channel Power (dBm)	Limit (dBm)	Margin (dB)
HE160, M0 to M11 1ss	1	-4.00	14.50		0.32	10.80	21.00	10.20
HE160, M0 to M11 1ss	2	-4.00	14.50	14.40	0.32	13.79	21.00	7.21
HE160, M0 to M11 2ss	2	-4.00	14.50	14.40	0.32	13.79	21.00	7.21
HE160 Beam Forming, M0 to M11 1ss	2	-1.00	12.30	12.30	0.32	14.64	21.00	6.36
HE160 Beam Forming, M0 to M11 2ss	2	-4.00	14.50	14.40	0.32	13.79	21.00	7.21
HE160 STBC, M0 to M11 2ss	2	-4.00	14.50	14.40	0.32	13.79	21.00	7.21

6185 MHz

Mode	Tx Paths	Correlated Antenna Gain (dBi)	Tx 1 Max Power (dBm)	Tx 2 Max Power (dBm)	Duty Cycle (dB)	Total Channel Power (dBm)	Limit (dBm)	Margin (dB)
HE160, M0 to M11 1ss	1	-4.00	16.30		0.32	12.64	21.00	8.36
HE160, M0 to M11 1ss	2	-4.00	16.30	16.60	0.32	15.78	21.00	5.22
HE160, M0 to M11 2ss	2	-4.00	16.30	16.60	0.32	15.78	21.00	5.22
HE160 Beam Forming, M0 to M11 1ss	2	-1.00	16.30	16.60	0.32	18.78	21.00	2.22
HE160 Beam Forming, M0 to M11 2ss	2	-4.00	16.30	16.60	0.32	15.78	21.00	5.22
HE160 STBC, M0 to M11 2ss	2	-4.00	16.30	16.60	0.32	15.78	21.00	5.22

6345 MHz

Mode	Tx Paths	Correlated Antenna Gain (dBi)	Tx 1 Max Power (dBm)	Tx 2 Max Power (dBm)	Duty Cycle (dB)	Total Channel Power (dBm)	Limit (dBm)	Margin (dB)
HE160, M0 to M11 1ss	1	-4.00	16.20		0.32	12.53	21.00	8.47
HE160, M0 to M11 1ss	2	-4.00	16.20	16.40	0.32	15.64	21.00	5.36
HE160, M0 to M11 2ss	2	-4.00	16.20	16.40	0.32	15.64	21.00	5.36
HE160 Beam Forming, M0 to M11 1ss	2	-1.00	16.20	16.40	0.32	18.64	21.00	2.36
HE160 Beam Forming, M0 to M11 2ss	2	-4.00	16.20	16.40	0.32	15.64	21.00	5.36
HE160 STBC, M0 to M11 2ss	2	-4.00	16.20	16.40	0.32	15.64	21.00	5.36