



FCC PART 15.407
 ISED RSS-247, ISSUE 2, FEBRUARY 2017
 DYNAMIC FREQUENCY SELECTION
 TEST REPORT



For

Cisco Systems, Inc.

125 West Tasman Drive,

San Jose, CA 95134, USA

FCC ID: LDKHDGWI1903
IC: 2461N-HDGWI1903

Report Type: Original Report	Product type: Cisco Catalyst C9117AX Series
Prepared By: Zhao Zhao Test Engineer	
Report Number: R1811136-DFS RevA	
Report Date: 2018-02-21	
Reviewed By: Xiao Lin RF Engineer	
Bay Area Compliance Laboratories Corporation (BACL) 1274 Anvilwood Avenue, Sunnyvale, CA 94089, USA Tel: 1 (408) 732-9162 Fax: 1 (408) 732-9164	

Note: This test report is prepared for the customer shown above and for the device described herein. It may not be duplicated or used in part without prior written consent from Bay Area Compliance Laboratories Corp. This report **must not** be used by the customer to claim product certification, approval, or endorsement by A2LA* or any agency of the Federal Government.

* This report may contain data that are not covered by the A2LA accreditation and are marked with an asterisk “*”

TABLE OF CONTENTS

1	GENERAL DESCRIPTION.....	4
1.1	PRODUCT DESCRIPTION FOR EQUIPMENT UNDER TEST (EUT).....	4
1.2	OBJECTIVE.....	4
1.3	RELATED SUBMITTAL(S)/GRANT(S)	4
1.4	TEST METHODOLOGY	4
1.5	MEASUREMENT UNCERTAINTY	5
1.6	TEST FACILITY REGISTRATIONS	5
1.7	TEST FACILITY ACCREDITATIONS.....	5
2	EUT TEST CONFIGURATION.....	8
2.1	JUSTIFICATION.....	8
2.2	EUT EXERCISE SOFTWARE.....	8
2.3	EQUIPMENT MODIFICATIONS.....	8
2.4	LOCAL SUPPORT EQUIPMENT	8
2.5	SUPPORT EQUIPMENT	9
2.6	INTERFACE PORTS AND CABLES	9
3	SUMMARY OF TEST RESULTS.....	10
4	APPLICABLE STANDARDS.....	11
4.1	DFS REQUIREMENT.....	11
4.2	DFS MEASUREMENT SYSTEM	14
4.3	SYSTEM BLOCK DIAGRAM.....	14
4.4	CONDUCTED METHOD.....	14
4.5	RADIATED METHOD	16
4.6	TEST PROCEDURE	16
5	TEST RESULTS.....	17
5.1	DESCRIPTION OF EUT.....	17
5.2	ANTENNA DESCRIPTION	17
5.3	TEST EQUIPMENT LIST AND DETAILS	17
5.4	RADAR WAVEFORM CALIBRATION.....	18
5.5	TEST ENVIRONMENTAL CONDITIONS.....	18
6	CHANNEL AVAILABILITY CHECK TIME (CAC).....	23
6.1	TEST PROCEDURE	23
7	CHANNEL MOVE TIME AND CHANNEL CLOSING TRANSMISSION TIME.....	26
7.1	TEST PROCEDURE	26
7.2	TEST RESULTS	26
8	NON-OCCUPANCY PERIOD.....	30
8.1	TEST PROCEDURE	30
8.2	TEST RESULTS	30
9	RADAR DETECTION BANDWIDTH & RADAR DETECTION PERFORMANCE CHECK.....	32
9.1	DETECTION BANDWIDTH.....	32
9.2	RADAR DETECTION PERFORMANCE CHECK.....	40
10	APPENDIX A (NORMATIVE) - U-NII-2A RADAR PARAMETER DATA SHEET.....	45
11	APPENDIX B (NORMATIVE) - U-NII-2C RADAR PARAMETER DATA SHEET.....	46
12	APPENDIX C (NORMATIVE) - DFS TEST SETUP PHOTO.....	47
13	APPENDIX D (NORMATIVE) - A2LA ELECTRICAL TESTING CERTIFICATE.....	48

DOCUMENT REVISION HISTORY

Revision Number	Report Number	Description of Revision	Date of Revision
0	R1811136-DFS	Original Report	2018-01-21
1	R1811136-DFS RevA	Adding EUT operating frequency bands for FCC and IC in Section 2.2. Revise 802.11 mode from ac to ax in Section 2.2. Correct editing error in Section A.1.	2018-02-21

1 General Description

1.1 Product Description for Equipment under Test (EUT)

This test and measurement report was prepared on behalf of *Cisco Systems, Inc.*, and their product model: *C9117AXI-B (US)*, *C9117AXI-A (Canada)*, FCC ID: LDKHDGWI1903; IC: 2461N- HDGWI1903 or the “EUT” as referred to in this report. The product is an 802.11ax Access Point.

1.2 Objective

This report is prepared on behalf of *Cisco Systems, Inc.* in accordance with FCC CFR47 §15.407 (h) & RSS 247 §6.3 and KDB: 905462 D02 UNII DFS Compliance Procedures New Rules v02.

The objective is to determine compliance with FCC rules for DFS Detection Threshold, Channel Availability Check Time, Uniform Spreading U-NII Detection Bandwidth, Channel Closing Transmission Time, and Channel Move time in Master Mode.

1.3 Related Submittal(s)/Grant(s)

R1811136-407.

1.4 Test Methodology

FCC CFR 47 Part2, Part15.407 (h)

RSS 247 §6.3

KDB: 905462 D02 UNII DFS Compliance Procedures New Rules v02.

COMPLIANCE MEASUREMENT PROCEDURES FOR UNLICENSED-NATIONAL INFORMATION INFRASTRUCTURE DEVICES OPERATING IN THE 5250-5350 MHz AND 5470-5725 MHz BANDS INCORPORATING DYNAMIC FREQUENCY SELECTION

1.5 Measurement Uncertainty

All measurements involve certain levels of uncertainties, especially in the field of EMC. The factors contributing to uncertainties are spectrum analyzer, cable loss, antenna factor calibration, antenna directivity, antenna factor variation with height, antenna phase center variation, antenna factor frequency interpolation, measurement distance variation, site imperfections, mismatch (average), and system repeatability.

Parameter	Measurement uncertainty
Occupied Channel Bandwidth	±5 %
RF output power, conducted	±0.57 dB
Power Spectral Density, conducted	±1.48dB
Unwanted Emissions, conducted	±1.57dB
All emissions, radiated	±4.0 dB
AC power line Conducted Emission	±2.0 dB
Temperature	±2 ° C
Humidity	±5 %
DC and low frequency voltages	±1.0 %
Time	±2 %
Duty Cycle	±3 %

1.6 Test Facility Registrations

BACL's test facilities that are used to perform Radiated and Conducted Emissions tests are currently recognized by the Federal Communications Commission as Accredited with NIST Designation Number US1129.

BACL's test facilities that are used to perform Radiated and Conducted Emissions tests are currently registered with Industry Canada under Registration Numbers: 3062A-1, 3062A-2, and 3062A-3.

BACL is a Chinese Taipei Bureau of Standards Metrology and Inspection (BSMI) validated Conformity Assessment Body (CAB), under Annex B, Phase I Procedures of the APEC Mutual Recognition Arrangement (MRA). BACL's BSMI Lab Code Number is: SL2-IN-E-1002R

BACL's test facilities that are used to perform AC Line Conducted Emissions, Telecommunications Line Conducted Emissions, Radiated Emissions from 30 MHz to 1 GHz, and Radiated Emissions from 1 GHz to 6 GHz are currently recognized as Accredited in accordance with the Voluntary Control Council for Interference [VCCI] Article 15 procedures under Registration Number A-0027.

1.7 Test Facility Accreditations

Bay Area Compliance Laboratories Corp. (BACL) is:

A- An independent, 3rd-Party, Commercial Test Laboratory accredited to ISO/IEC 17025:2005 by A2LA (Test Laboratory Accreditation Certificate Number 3279.02), in the fields of: Electromagnetic Compatibility and Telecommunications. Unless noted by an Asterisk (*) in the Compliance Matrix (See Section 3 of this Test Report), BACL's ISO/IEC 17025:2005 Scope of Accreditation includes all of the Test Method Standards and/or the Product Family Standards detailed in this Test Report..

BACL's ISO/IEC 17025:2005 Scope of Accreditation includes a comprehensive suite of EMC Emissions, EMC Immunity, Radio, RF Exposure, Safety and wireline Telecommunications test methods applicable to a wide range of product categories. These product categories include Central Office Telecommunications Equipment [including NEBS - Network Equipment Building Systems], Unlicensed and Licensed Wireless and RF devices, Information Technology Equipment (ITE); Telecommunications Terminal Equipment (TTE); Medical Electrical

Equipment; Industrial, Scientific and Medical Test Equipment; Professional Audio and Video Equipment; Industrial and Scientific Instruments and Laboratory Apparatus; Cable Distribution Systems, and Energy Efficient Lighting.

B- A Product Certification Body accredited to ISO/IEC 17065:2012 by A2LA (Product Certification Body Accreditation Certificate Number 3279.03) to certify

- For the USA (Federal Communications Commission):
 - 1- All Unlicensed radio frequency devices within FCC Scopes A1, A2, A3, and A4;
 - 2- All Licensed radio frequency devices within FCC Scopes B1, B2, B3, and B4;
 - 3- All Telephone Terminal Equipment within FCC Scope C.
- For the Canada (Industry Canada):
 - 1 All Scope 1-Licence-Exempt Radio Frequency Devices;
 - 2 All Scope 2-Licensed Personal Mobile Radio Services;
 - 3 All Scope 3-Licensed General Mobile & Fixed Radio Services;
 - 4 All Scope 4-Licensed Maritime & Aviation Radio Services;
 - 5 All Scope 5-Licensed Fixed Microwave Radio Services
 - 6 All Broadcasting Technical Standards (BETS) in the Category I Equipment Standards List.
- For Singapore (Info-Communications Development Authority (IDA)):
 - 1 All Line Terminal Equipment: All Technical Specifications for Line Terminal Equipment – Table 1 of IDA MRA Recognition Scheme: 2011, Annex 2
 2. All Radio-Communication Equipment: All Technical Specifications for Radio-Communication Equipment – Table 2 of IDA MRA Recognition Scheme: 2011, Annex 2
- For the Hong Kong Special Administrative Region:
 - 1 All Radio Equipment, per KHCA 10XX-series Specifications;
 - 2 All GMDSS Marine Radio Equipment, per HKCA 12XX-series Specifications;
 - 3 All Fixed Network Equipment, per HKCA 20XX-series Specifications.
- For Japan:
 - 1 MIC Telecommunication Business Law (Terminal Equipment):
 - All Scope A1 - Terminal Equipment for the Purpose of Calls;
 - All Scope A2 - Other Terminal Equipment
 - 2 Radio Law (Radio Equipment):
 - All Scope B1 - Specified Radio Equipment specified in Article 38-2-2, paragraph 1, item 1 of the Radio Law
 - All Scope B2 - Specified Radio Equipment specified in Article 38-2-2, paragraph 1, item 2 of the Radio Law
 - All Scope B3 - Specified Radio Equipment specified in Article 38-2-2, paragraph 1, item 3 of the Radio Law

C- A Product Certification Body accredited to ISO/IEC 17065:2012 by A2LA (Product Certification Body Accreditation Certificate Number 3279.01) to certify Products to USA's Environmental Protection Agency (EPA) ENERGY STAR Product Specifications for:

- 1 Electronics and Office Equipment:
 - for Telephony (ver. 3.0)
 - for Audio/Video (ver. 3.0)
 - for Battery Charging Systems (ver. 1.1)
 - for Set-top Boxes & Cable Boxes (ver. 4.1)
 - for Televisions (ver. 6.1)
 - for Computers (ver. 6.0)
 - for Displays (ver. 6.0)
 - for Imaging Equipment (ver. 2.0)
 - for Computer Servers (ver. 2.0)
- 2 Commercial Food Service Equipment
 - for Commercial Dishwashers (ver. 2.0)

- for Commercial Ice Machines (ver. 2.0)
- for Commercial Ovens (ver. 2.1)
- for Commercial Refrigerators and Freezers
- 3 Lighting Products
 - For Decorative Light Strings (ver. 1.5)
 - For Luminaires (including sub-components) and Lamps (ver. 1.2)
 - For Compact Fluorescent Lamps (CFLs) (ver. 4.3)
 - For Integral LED Lamps (ver. 1.4)
- 4 Heating, Ventilation, and AC Products
 - for Residential Ceiling Fans (ver. 3.0)
 - for Residential Ventilating Fans (ver. 3.2)
- 5 Other
 - For Water Coolers (ver. 3.0)

D- A NIST Designated Phase-I and Phase-II Conformity Assessment Body (CAB) for the following economies and regulatory authorities under the terms of the stated MRAs/Treaties:

- Australia: ACMA (Australian Communication and Media Authority) – APEC Tel MRA -Phase I;
- Canada: (Innovation, Science and Economic development Canada - ISEDC) Foreign Certification Body – FCB – APEC Tel MRA -Phase I & Phase II;
- Chinese Taipei (Republic of China – Taiwan):
 - o BSMI (Bureau of Standards, Metrology and Inspection) APEC Tel MRA -Phase I;
 - o NCC (National Communications Commission) APEC Tel MRA -Phase I;
- European Union:
 - o EMC Directive 2014/30/EU US-EU EMC & Telecom MRA CAB (NB)
 - o Radio Equipment (RE) Directive 2014/53/EU US-EU EMC & Telecom MRA CAB (NB)
 - o Low Voltage Directive (LVD) 2014/35/EU
- Hong Kong Special Administrative Region: (Office of the Telecommunications Authority – OFTA) APEC Tel MRA -Phase I & Phase II
- Israel – US-Israel MRA Phase I
- Republic of Korea (Ministry of Communications - Radio Research Laboratory) APEC Tel MRA -Phase I
- Singapore: (Infocomm Media Development Authority - IMDA) APEC Tel MRA -Phase I & Phase II;
- Japan: VCCI - Voluntary Control Council for Interference US-Japan Telecom Treaty VCCI Side Letter-
- USA:
 - o ENERGY STAR Recognized Test Laboratory – US EPA
 - o Telecommunications Certification Body (TCB) – US FCC;
 - o Nationally Recognized Test Laboratory (NRTL) – US OSHA

Vietnam: APEC Tel MRA -Phase I;

2 EUT Test Configuration

2.1 Justification

The EUT was configured for testing according to FCC CFR47 §15.407 (h) & RSS 247 §6.3, and KDB: 905462 D02 UNII DFS Compliance Procedures New Rules v02.

2.2 EUT Exercise Software

The custom DFS SW was provided by Cisco Systems, Inc., and was verified by *Chin Ming Lui* and *Zhao Zhao* to comply with the standard requirements being tested against.

The EUT operates in the following DFS frequency bands:

FCC: 5260-5320/5270-5310/5290/5250 MHz, 5500-5720/5510-5710/5530-5690/5570 MHz

ISED: 5260-5320/5270-5310/5290/5250 MHz, 5500-5700/5510-5670/5530 MHz

Note: EUT does not support any channels fall into 5600-5650 MHz band in Canada.

The following channels were selected for testing.

Modulation	Band	Channel	Frequency (MHz)
802.11ax20 mode	U-NII-2A	56	5280
	U-NII-2C	100	5500
802.11ax40 mode	U-NII-2A	54	5270
	U-NII-2C	102	5510
802.11ax80 mode	U-NII-2A	58	5290
	U-NII-2C	106	5530
802.11ax160 mode	U-NII-2A	50	5250
	U-NII-2C	114 (FCC only)	5570

2.3 Equipment Modifications

N/A

2.4 Local Support Equipment

Manufacturer	Description	Model
Dell	Laptop	Latitude E6410
Dell	Laptop	Latitude E5420

2.5 Support Equipment

Manufacturer	Description	Model
Cisco	Cisco Gigabit Power over Ethernet Injector	SB-PWR-INJ2
Cisco	AP (Uses as client)	AP3800

2.6 Interface Ports and Cables

Cable Description	Length (m)	To	From
USB to RS232 (Male)	0.5	Laptop	RS232 (Female)
RS232 (Female) to Ethernet Port	1	EUT	RS232 (Male)
Cat5e	~5	EUT	Cisco Gigabit Power over Ethernet Injector

3 Summary of Test Results

The following result table represents the list of measurements required under the FCC CFR47 §15.407 (h) & RSS 247 §6.3, and KDB: 905462 D02 UNII DFS Compliance Procedures New Rules v02.

Items	Description of Test (Master)	Results
Detection Bandwidth	UNII Detection Bandwidth	Compliant
Performance Requirements Check	Initial Channel Availability Check Time (CAC)	Compliant
	Radar Burst at the Beginning of the CAC	Compliant
	Radar Burst at the End of the CAC	Compliant
In-Service Monitoring	Channel Move Time	Compliant
	Channel Closing Transmission Time	Compliant
	Non-Occupancy Period	Compliant
Radar Detection	Statistical Performance Check	Compliant

4 Applicable Standards

4.1 DFS Requirement

FCC CFR47 §15.407 (h) & RSS 247 §6.3, and KDB: 905462 D02 UNII DFS Compliance Procedures New Rules v02.

Table 1: Applicability of DFS requirements prior to use of a channel

Requirement	Operational Mode		
	Master	Client (Without radar detection)	Client (With radar detection)
Non-Occupancy Period	Yes	Not Required	Yes
DFS Detection Threshold	Yes	Not Required	Yes
Channel Availability Check Time	Yes	Not Required	Not Required
U-NII Detection Bandwidth	Yes	Not Required	Yes

Table 2: Applicability of DFS requirements during normal operation

Requirement	Operational Mode	
	Master Device or Client with Radar Detection	Client Without Radar Detection
DFS Detection Threshold	Yes	Not Required
Channel Closing Transmission Time	Yes	Yes
Channel Move Time	Yes	Yes
U-NII Detection Bandwidth	Yes	Not Required

Additional requirements for devices with multiple bandwidth modes	Master Device or Client with Radar Detection	Client Without Radar Detection
U-NII Detection Bandwidth and Statistical Performance Check	All BW modes must be tested	Not required
Channel Move Time and Channel Closing Transmission Time	Test using widest BW mode available	Test using the widest BW mode available for the link
All other tests	Any single BW mode	Not required

Note: Frequencies selected for statistical performance check (Section 7.8.4) should include several frequencies within the radar detection bandwidth and frequencies near the edge of the radar detection bandwidth. For 802.11 devices it is suggested to select frequencies in each of the bonded 20 MHz channels and the channel center frequency.

Table 3: Interference Threshold for Master and Client with Radar Detection

Maximum Transmit Power	Value (See Notes 1, 2 and 3)
EIRP \geq 200 milliwatt	-64 dBm
EIRP< 200 milliwatt and power spectral density < 10dBm/MHz	-62 dBm
EIRP< 200 milliwatt that do not meet the power spectral density requirement	-64 dBm

Note 1: This is the level at the input of the receiver assuming a 0 dBi receive antenna.
Note 2: Throughout these test procedures an additional 1 dB has been added to the amplitude of the test transmission waveforms to account for variations in measurement equipment. This will ensure that the test signal is at or above the detection threshold level to trigger a DFS response.
Note3: EIRP is based on the highest antenna gain. For MIMO devices refer to KDB Publication 662911 D01.

Table 4: DFS Response Requirement Values

Parameter	Value
Non-occupancy period	Minimum 30 minutes
Channel Availability Check Time	60 seconds
Channel Move Time	10 seconds <i>See Note 1.</i>
Channel Closing Transmission Time	200 milliseconds + an aggregate of 60 milliseconds over remaining 10 second period. <i>See Notes 1 and 2.</i>
U-NII Detection Bandwidth	Minimum 100% of the UNII 99% transmission power bandwidth. <i>See Note 3.</i>

Note 1: Channel Move Time and the Channel Closing Transmission Time should be performed with Radar Type 0. The measurement timing begins at the end of the Radar Type 0 burst.

Note 2: The Channel Closing Transmission Time is comprised of 200 milliseconds starting at the beginning of the Channel Move Time plus any additional intermittent control signals required to facilitate a Channel move (an aggregate of 60 milliseconds) during the remainder of the 10 second period. The aggregate duration of control signals will not count quiet periods in between transmissions.

Note 3: During the U-NII Detection Bandwidth detection test, radar type 0 should be used. For each frequency step the minimum percentage of detection is 90 percent. Measurements are performed with no data traffic.

Table 5: Short Pulse Radar Test Waveforms

Radar Type	Pulse Width (Microseconds)	PRI (Microseconds)	Pulses	Minimum Percentage of Successful Detection	Minimum Number of Trials
0	1	1428	18	See Note 1	See Note 1
1	1	Test A: 15 unique PRI values randomly selected from the list of 23 PRI values in Table 5a Test B: 15 unique PRI values randomly selected within the range of 518-3066 μ sec, with a minimum increment of 1 μ sec, excluding PRI values selected in Test A	$\text{Roundup} \left\{ \begin{array}{l} \left(\frac{1}{360} \right) \\ \left(\frac{19 \cdot 10^6}{\text{PRI}_{\mu\text{sec}}} \right) \end{array} \right.$	60%	30
2	1-5	150-230	23-29	60%	30
3	6-10	200-500	16-18	60%	30
4	11-20	200-500	12-16	60%	30
Aggregate (Radar Types 1-4)				80%	120
Note 1: Short Pulse Radar Type 0 should be used for the detection bandwidth test, channel move time, and channel closing time tests.					

Table 6: Long Pulse Radar Test Signal

Radar Type	Bursts	Chirp Width (MHz)	PRI (usec)	Number of Pulses per Burst	Number of Bursts	Minimum Percentage of Successful Detection	Minimum Number of Trials
5	50-100	5-20	1000-2000	1-3	8-20	80%	30

Table 7: Frequency Hopping Radar Test Signal

Radar Type	Pulse Width (usec)	PRI (usec)	Pulses per Hop	Hopping Rate (kHz)	Hopping Sequence Length (msec)	Minimum Percentage of Successful Detection	Minimum Number of Trials
6	1	333	9	0.333	300	70%	30

4.2 DFS Measurement System

BACL DFS measurement system consists of two subsystems: (1) The radar signal generating subsystem and (2) the traffic monitoring subsystem.

4.3 System Block Diagram

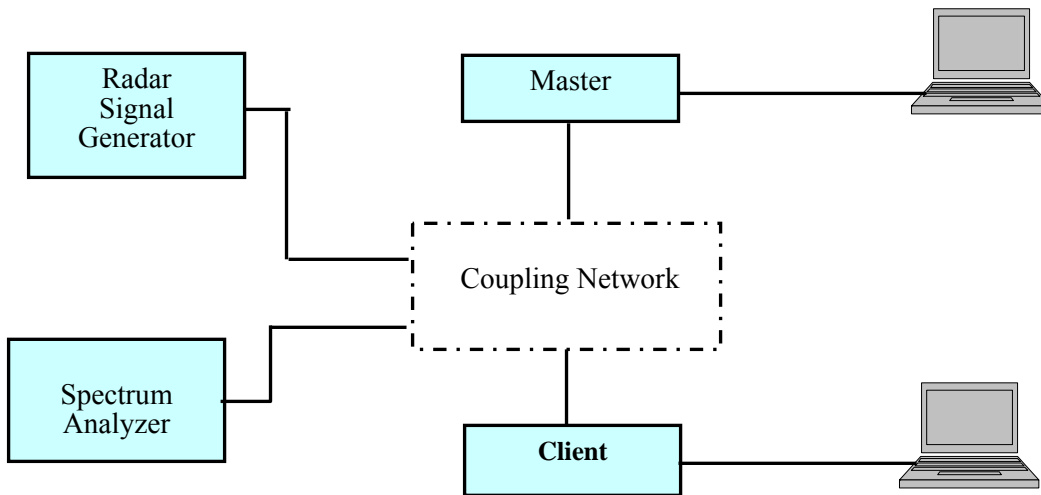

4.4 Conducted Method

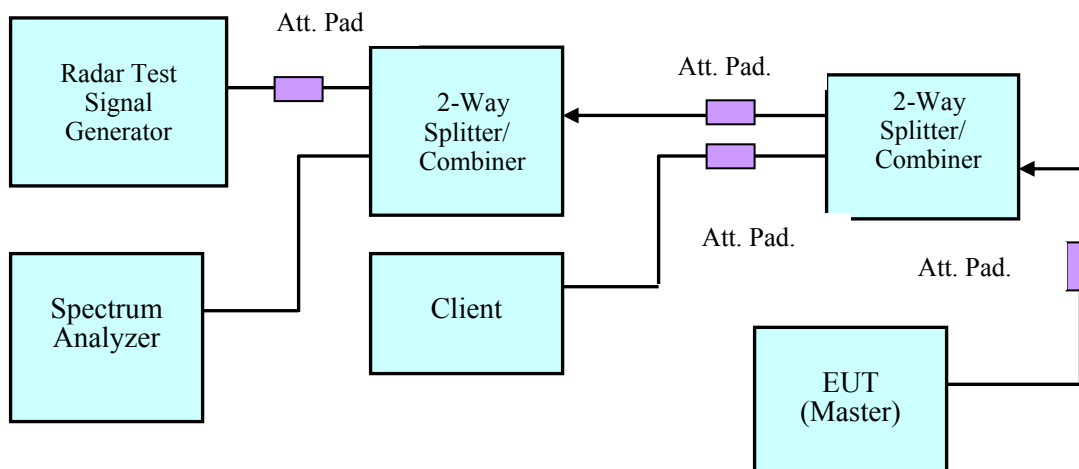

Setup for Master with injection at the Master

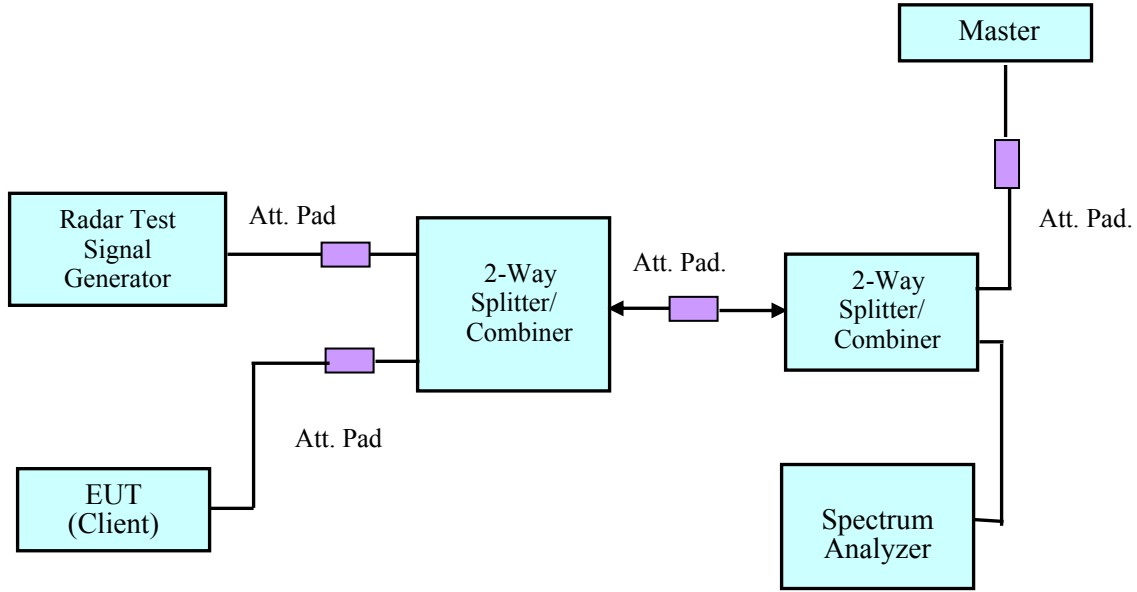

Setup for Client with injection at the Master

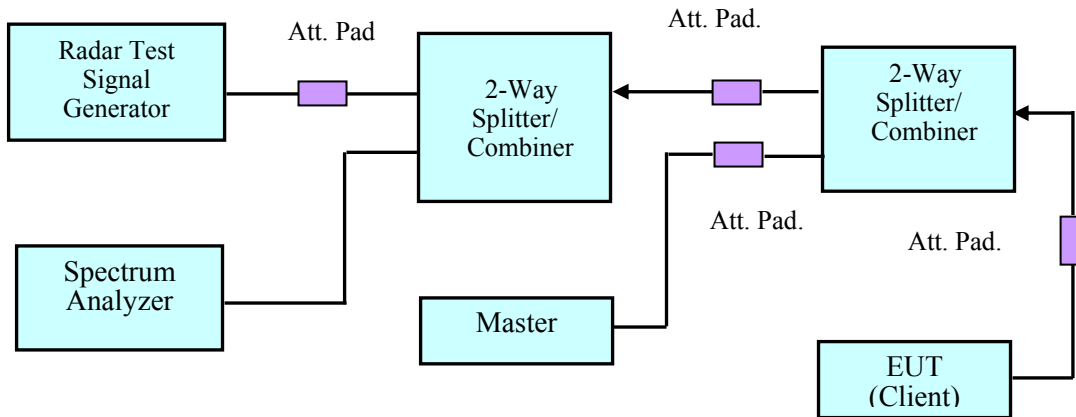

Setup for Client with injection at the Client

4.5 Radiated Method

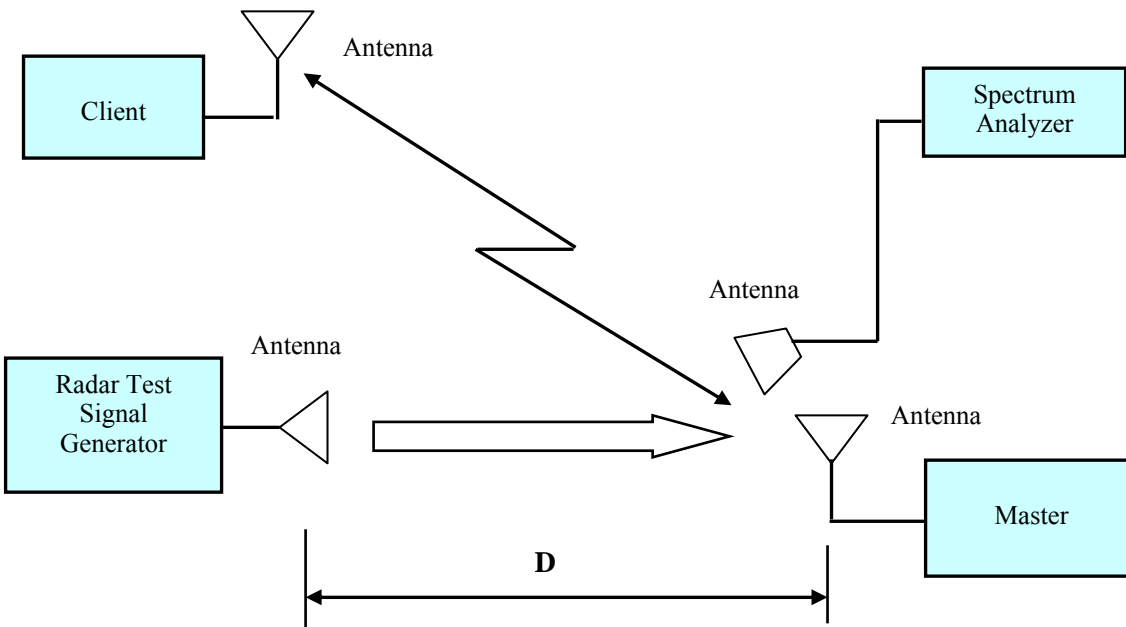

4.6 Test Procedure

A spectrum analyzer is used as a monitor that verifies the EUT's status, which includes the Channel Closing Transmission Time and the Channel Move Time. The Spectrum analyzer is used to monitor the equipment under test (EUT) does not transmit on the same channel during the Non-Occupied Period after the radar detection. It is also used to monitor EUT transmissions during the Channel Availability Check Time.

5 Test Results

5.1 Description of EUT

The EUT operates in 5250-5350 MHz and 5470-5725 MHz range in Master and Client with radar detection Mode.

The rated output power of EUT is > 23 dBm (EIRP), Therefore the required interference threshold level is -64 dBm, the required radiated threshold at antenna port is -64 dBm.

The calibrated radiated DFS detection threshold level is set to -64 dBm.

WLAN traffic was generated by using Iperf. The EUT can be configured to Master mode or Client Mode by using Mimoso UI.

5.2 Antenna Description

Antenna usage	Band of Operation (MHz)	Maximum Antenna Gain (dBi)
Wi-Fi	5000-6000	6
Wi-Fi	2400-2500	4
BLE	2400-2500	2

5.3 Test Equipment List and Details

Manufacturer	Equipment Description	Model	S/N	Calibration Date	Calibration Interval
National Instruments	NI PXI-1042 8-Slot chassis	PXI-1042	V08X01EE1	N/A	N/A
National Instruments	Arbitrary Waveform Generator	PXI-5421	N/A	N/A	N/A
National Instruments	RF Upconverter	PXI-5610	N/A	N/A	N/A
ASCOR	Upconverter	AS-7206	N/A	N/A	N/A
Agilent	Analyzer, Spectrum	E4446A	MY45303156	2018-02-26	1 year
Mini-Circuits	Splitter/Combiner	2FSC-2-9G+	N/A	N/A	N/A
Pulsar	Splitter/Combiner	PS4-09-452/4S	N/A	N/A	N/A
-	RF Cables	C00011	N/A	Each Time	N/A
Mini-Circuits	Attenuator	BW-S30W2	N/A	N/A	N/A

Statement of Traceability: *BACL Corp.* attests that all of the calibrations on the equipment items listed above were traceable to NIST or to another internationally recognized National Metrology Institute (NMI), and were compliant with A2LA Policy P102 (dated 09 June 2016) "A2LA Policy on Metrological Traceability".

5.4 Radar Waveform Calibration

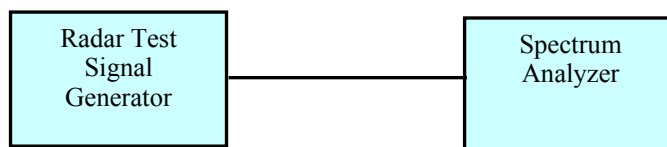

Conducted Calibration Setup Block Diagram

5.5 Test Environmental Conditions

Temperature:	22-25 °C
Relative Humidity:	33-37 %
ATM Pressure:	101.7-102.4 kPa

Testing was performed by Chin Ming Lui from 2018-12-12 to 2018-12-31, and Zhao Zhao from 2019-01-16 to 2019-01-21 at the DFS site.

Plots of Radar Waveforms

5570 MHz

Radar Type 0

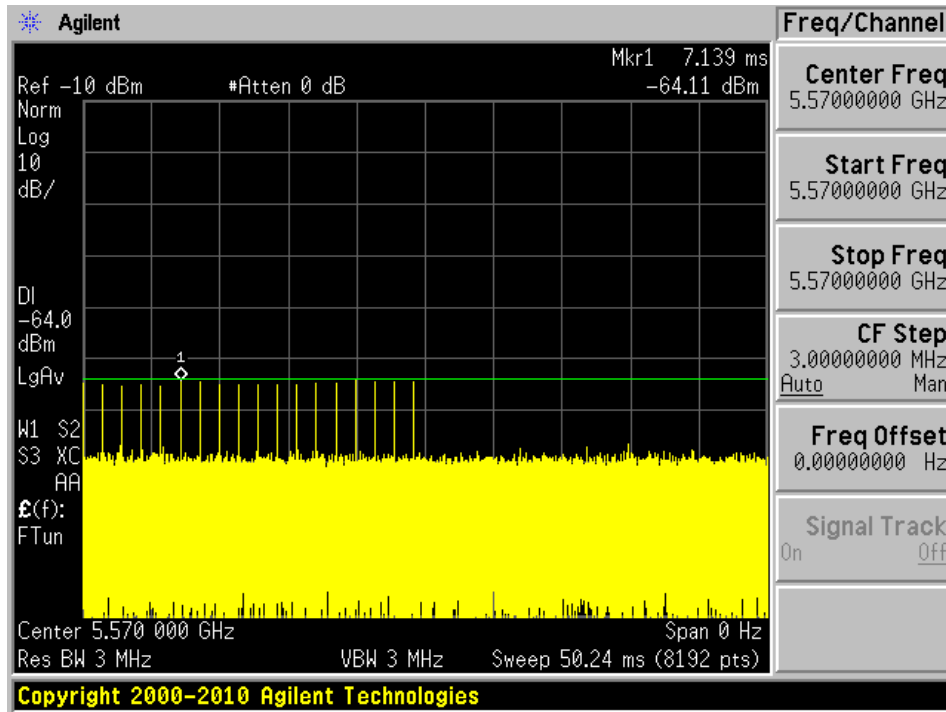

Radar Type 1A

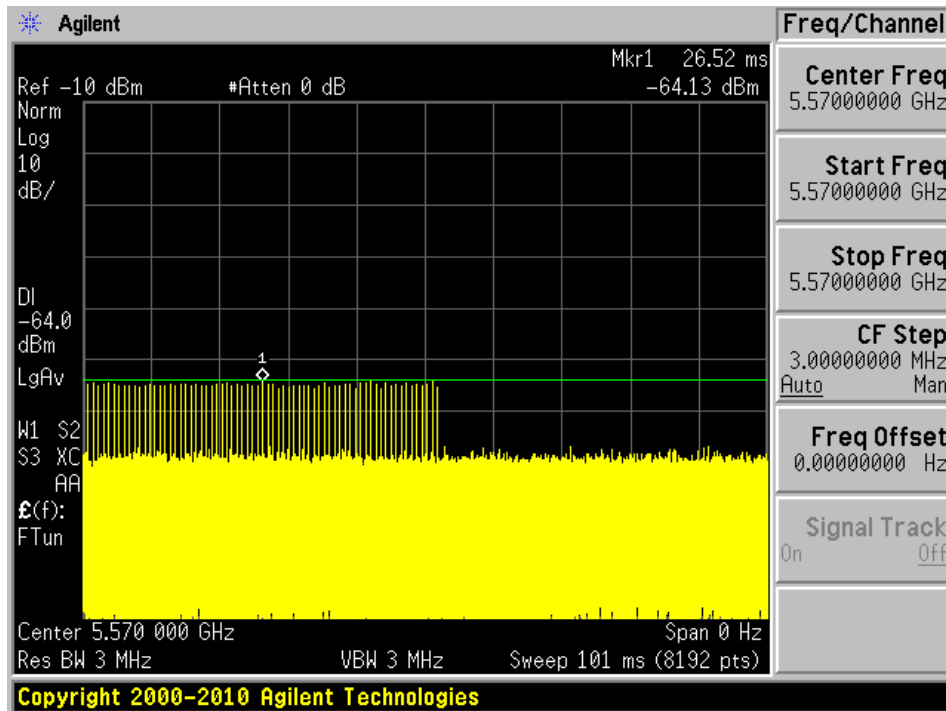

Radar Type 1B

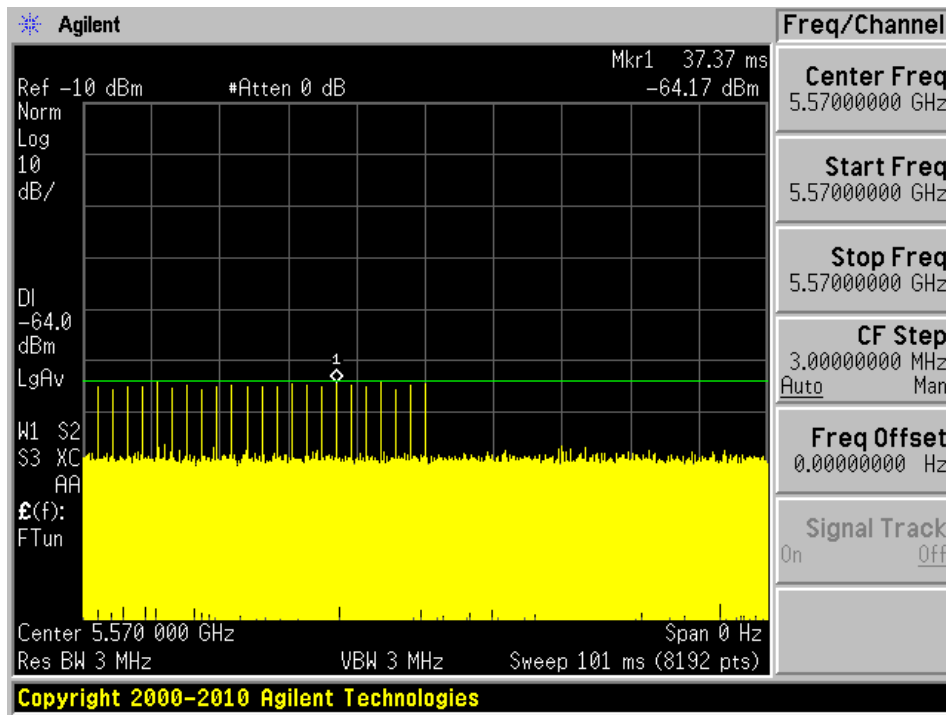

Radar Type 2

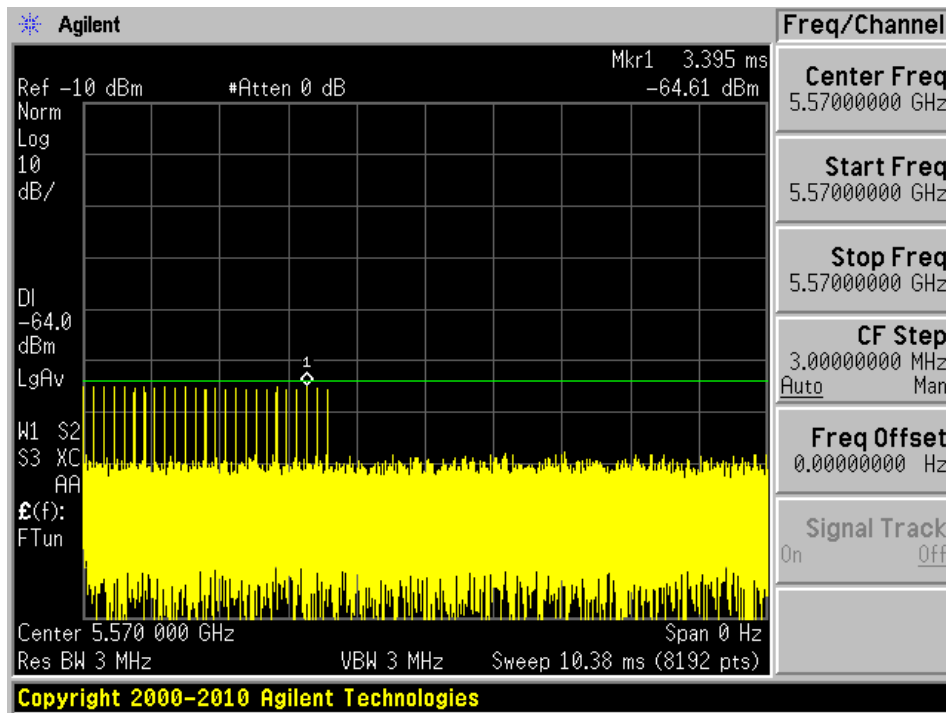

Radar Type 3

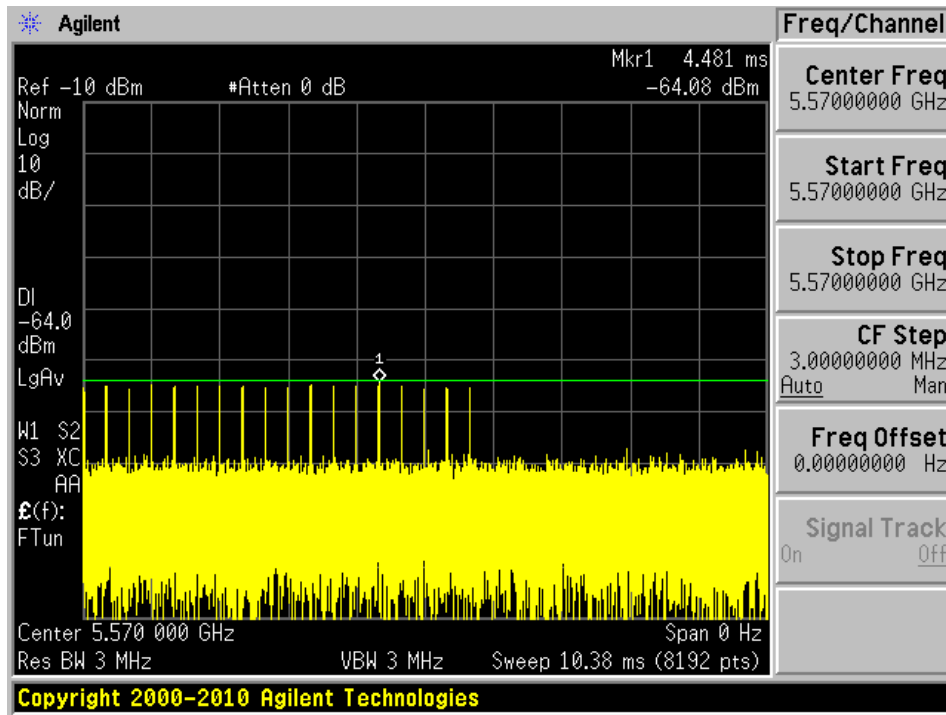

Radar Type 4

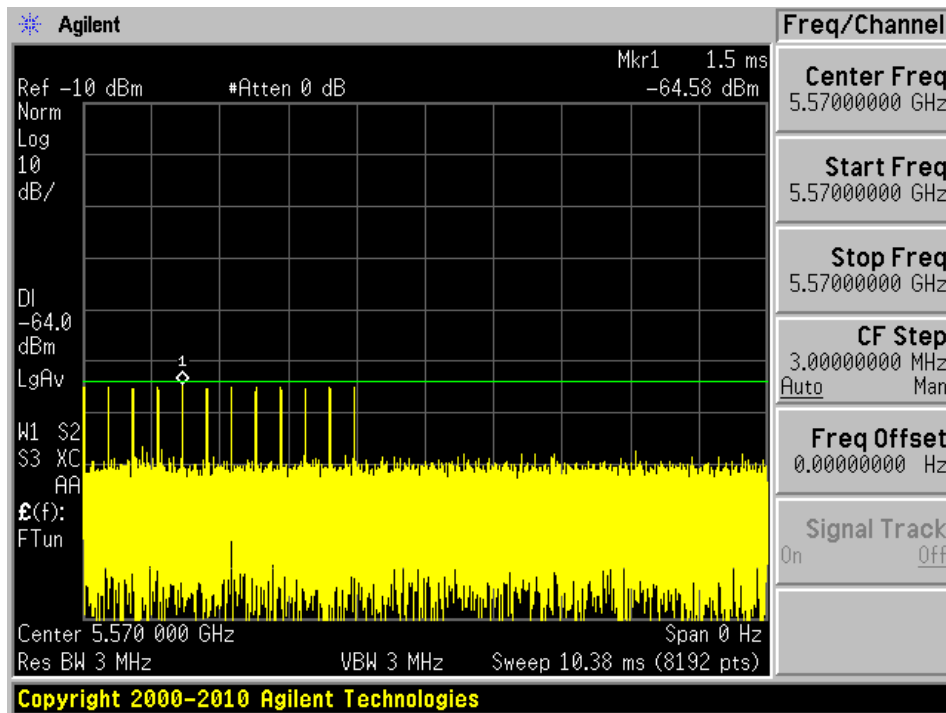

Radar Type 5

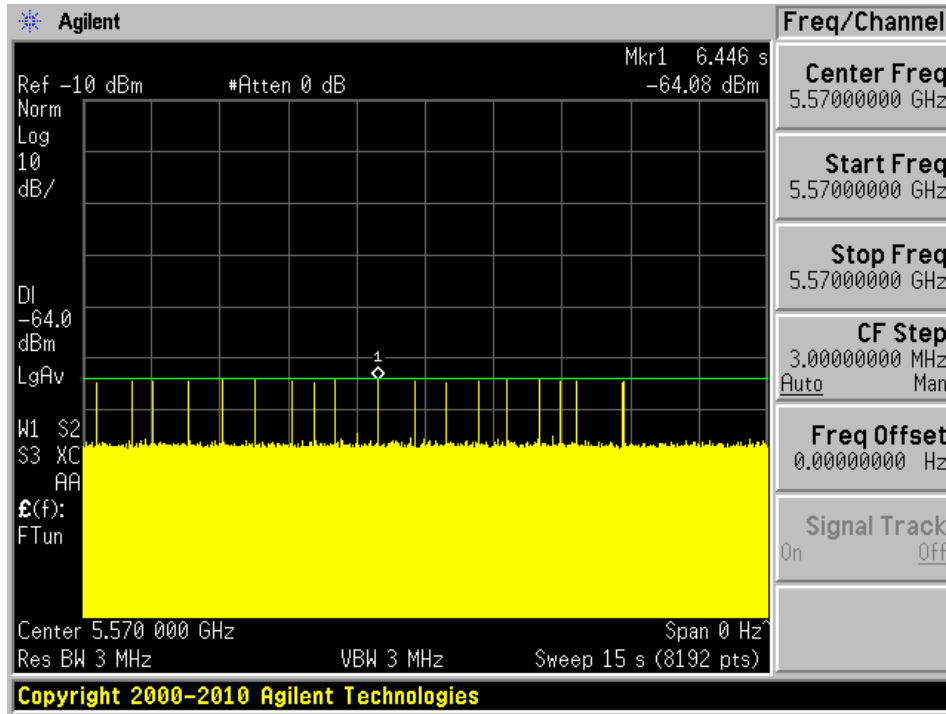

Radar Type 6

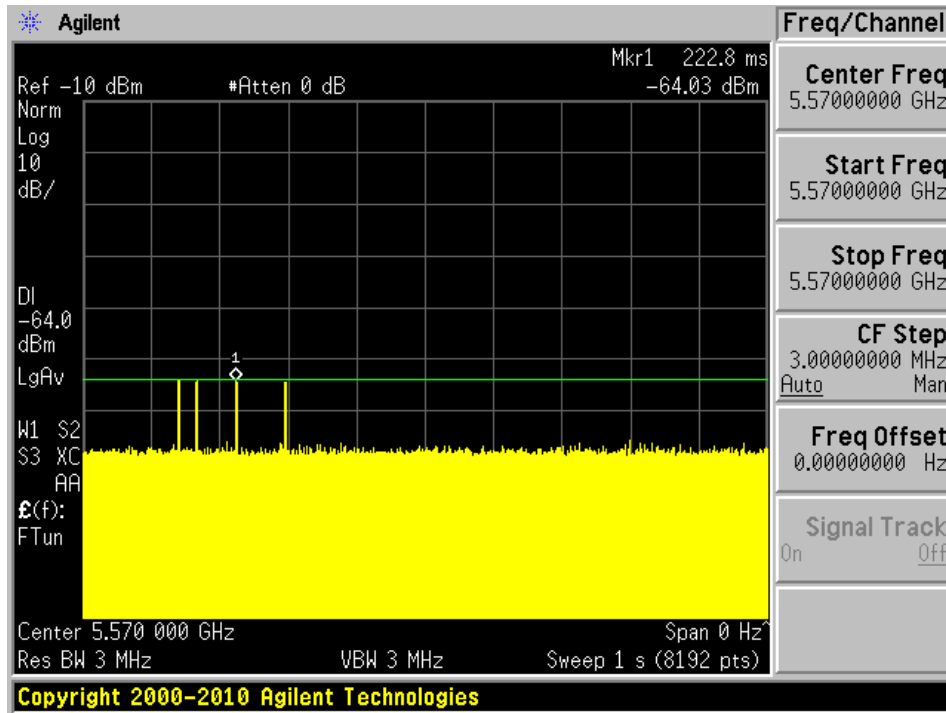

6 Channel Availability Check Time (CAC)

6.1 Test Procedure

- 1) Use the command to turn on the Channel, meanwhile, press the timer to record until the CAC expired. There are commands popping up in the command window indicates that the CAC Time has expired.
- 2) With link established on channel, apply a radar signal within 0~6 seconds after using the Channel turning on commands; monitor the transmissions on channel from the spectrum analyzer.
- 3) Reboot EUT, with a link established on channel, apply a radar signal within 56~62 seconds after the after using the Channel turning on commands, and monitor the transmission on channel from the spectrum analyzer.

Results:

CAC Total Time: 62 Seconds

Timing of Radar Burst	Spectrum Analyzer Display	Result
No Radar Triggered	Transmission begin after power-up cycle 62 seconds CAC	Pass
Within 6 seconds of the CAC starting	No transmission	Pass
Within the last 6 seconds of the CAC	No transmission	Pass

Note: The CAC test is with the Radar type 0.

5280 MHz

Plot of Radar signal applied within 6 seconds of start of CAC

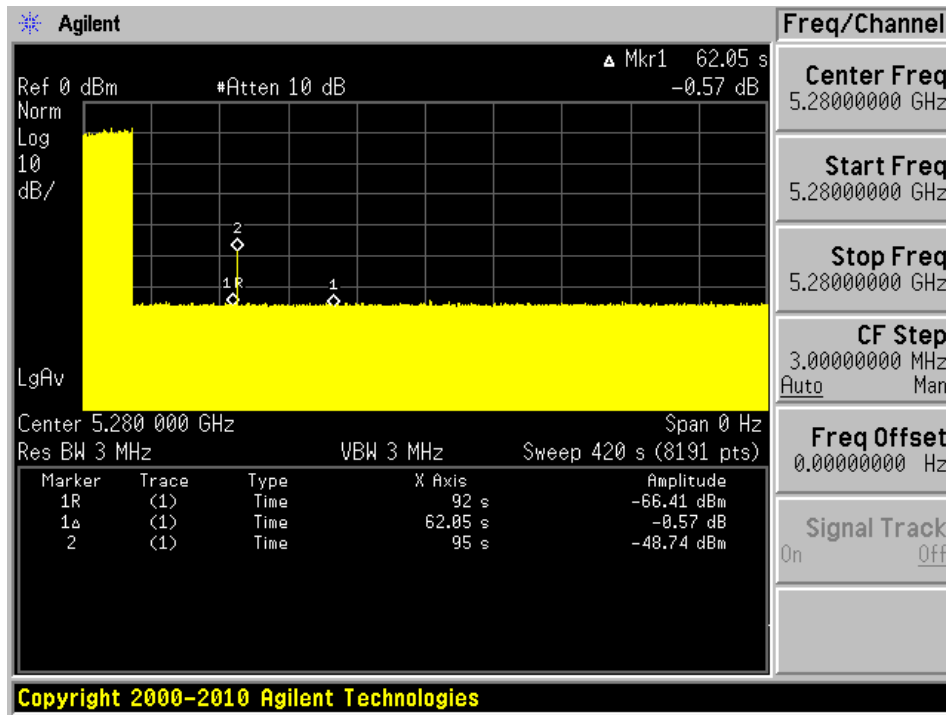

No transmissions found after radar signal applied.

Plot of Radar signal applied at the end of 6 seconds of CAC

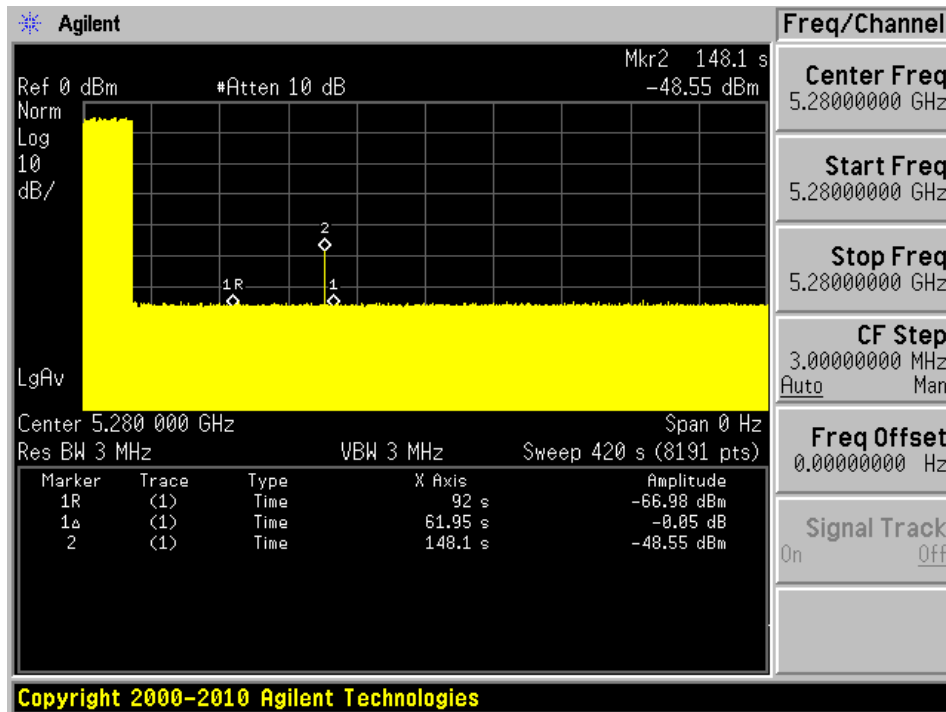

No transmissions found after radar signal applied.

5500 MHz

Plot of Radar signal applied within 6 seconds of start of CAC

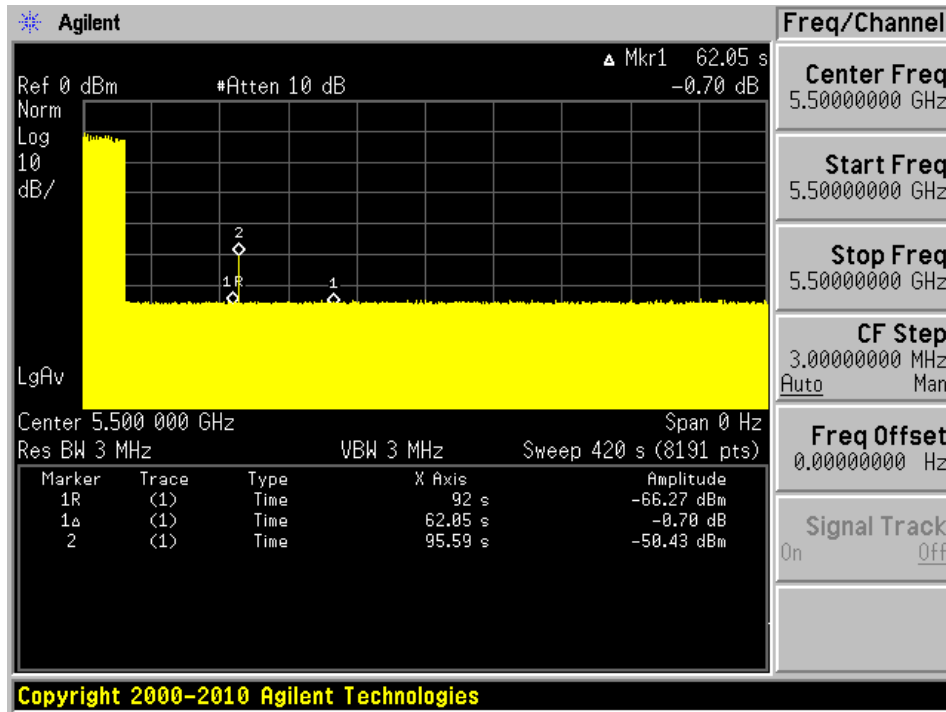

No transmissions found after radar signal applied.

Plot of Radar signal applied at the end of 6 seconds of CAC

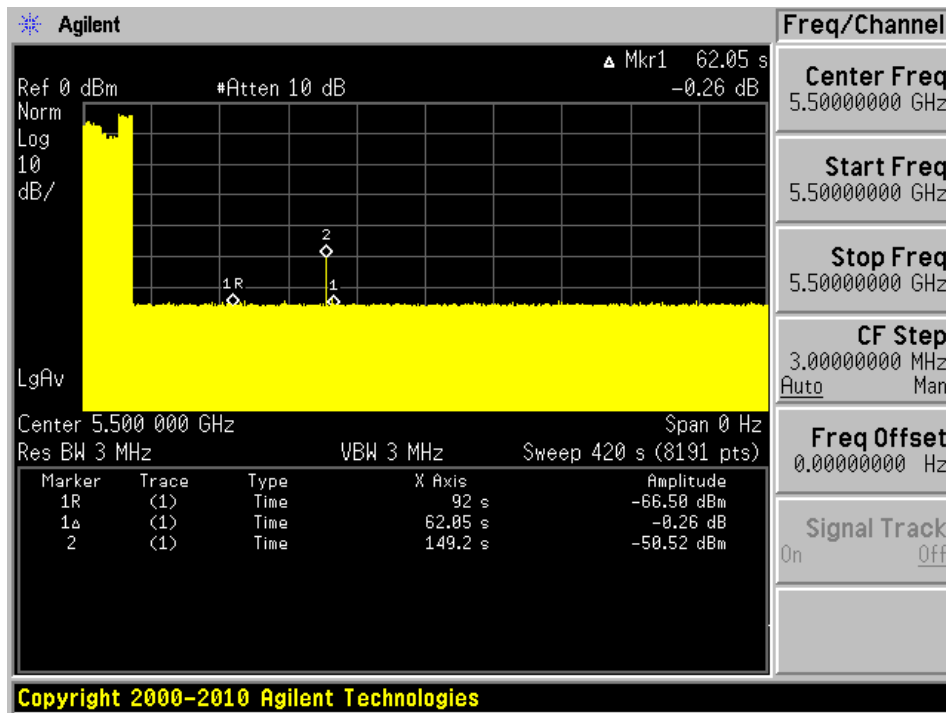

No transmissions found after radar signal applied.

7 Channel Move Time and Channel Closing Transmission Time

7.1 Test Procedure

BACL use type 0 radar signal to test the channel move time and channel closing transmission time.

The aggregate channel closing transmission time is calculated as follows:

Aggregate Transmission Time = N * Dwell Time

N is the number of spectrum analyzer bins showing a device transmission

Dwell Time is the dwell time per bin (i.e. Dwell Time = S/B, S is the sweep time and B is the number of bin, i.e. 8192)

7.2 Test Results

FCC:

Frequency (MHz)	Bandwidth (MHz)	Radar Type	Results
5250	160	Type 0	Compliant
5570	160	Type 0	Compliant

ISED:

Frequency (MHz)	Bandwidth (MHz)	Radar Type	Results
5250	160	Type 0	Compliant
5530	80	Type 0	Compliant

Please refer to the following tables and plots.

5250 MHz, Bandwidth 160 MHz

Type 0 radar channel move time and channel closing transmission time result:

Channel closing transmitting time (ms)	Limit (ms)	Result
21.98	200+60	Pass
7.325	60	Pass

Channel move time (s)	Limit (s)	Result
< 10	10	Pass

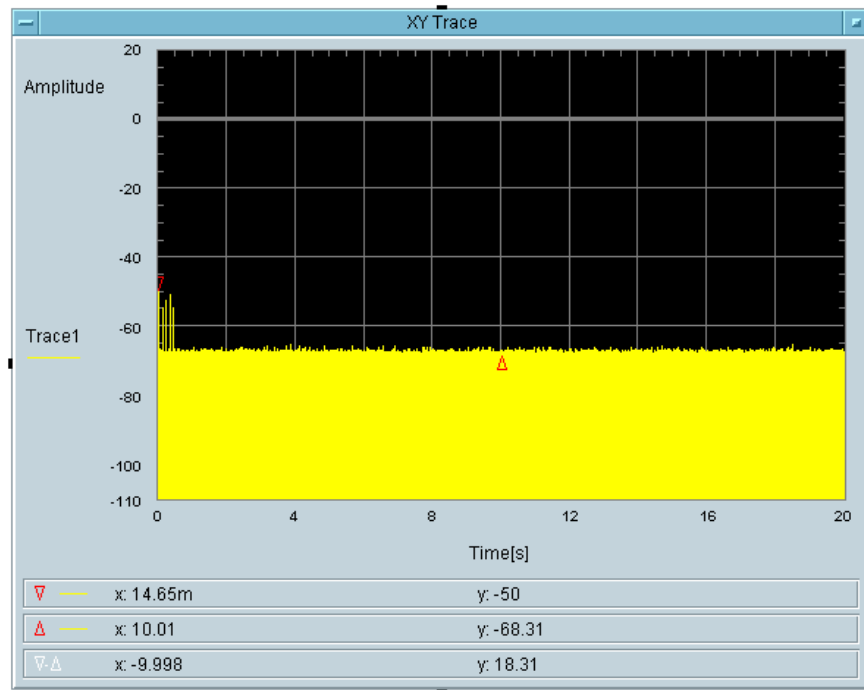

— Total On Time [s] —
21.98m

— Total On Time After Delay [s] —
7.325m

5570 MHz, Bandwidth 160 MHz

Type 0 radar channel move time and channel closing transmission time result:

Channel closing transmitting time (ms)	Limit (ms)	Result
21.98	200+60	Pass
4.884	60	Pass

Channel move time (s)	Limit (s)	Result
< 10	10	Pass

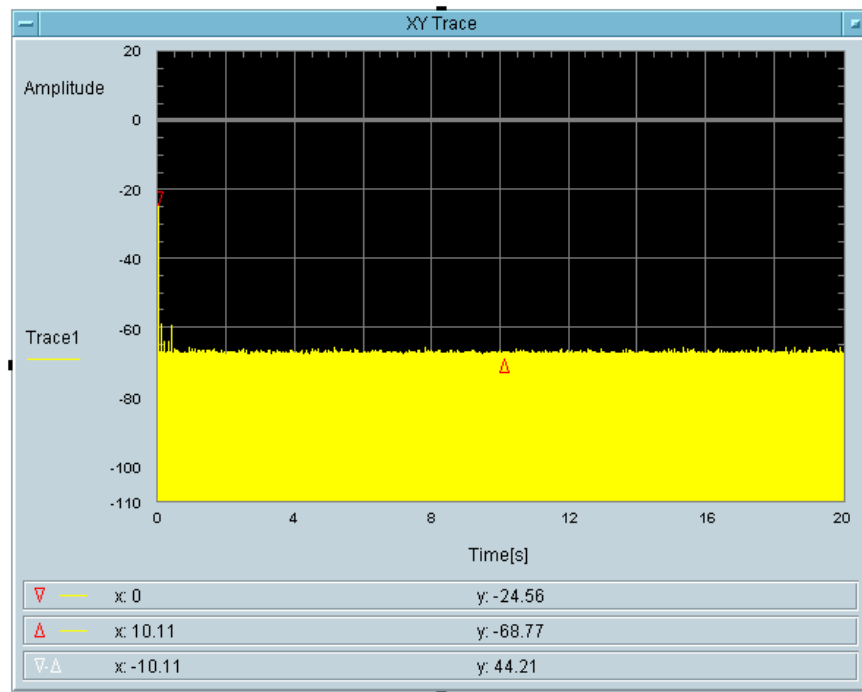

Total On Time [s]
21.98m

Total On Time After Delay [s]
4.884m

5530 MHz, Bandwidth 80 MHz

Type 0 radar channel move time and channel closing transmission time result:

Channel closing transmitting time (ms)	Limit (ms)	Result
14.65	200+60	Pass
7.324	60	Pass

Channel move time (s)	Limit (s)	Result
< 10	10	Pass

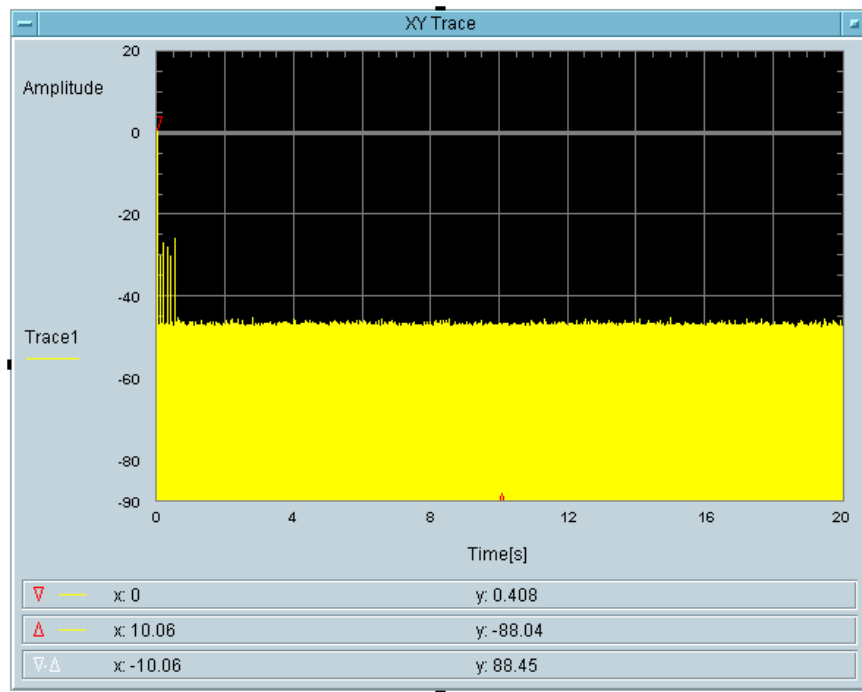

Total On Time [s]
14.65m

Total On Time After Delay [s]
7.324m

8 Non-Occupancy Period

8.1 Test Procedure

Measure the EUT for more than 30 minutes following the channel close/move time to verify that the EUT does not resume any transmissions on this channel. Provide one plot to demonstrate no transmission on the channel for the non-occupancy period (30 minutes observation time)

8.2 Test Results

Frequency (MHz)	Bandwidth (MHz)	Spectrum Analyzer Display
5280	20	No transmission within 30 minutes
5500	20	No transmission within 30 minutes

Please refer to the following plots.

5280 MHz, Bandwidth 20 MHz

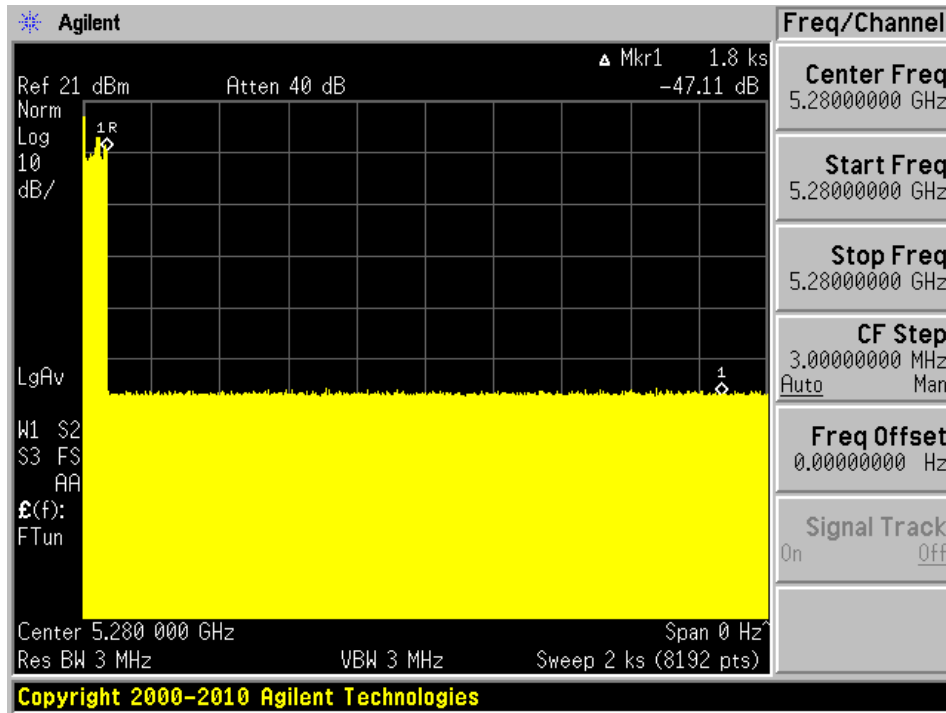

5500 MHz, Bandwidth 20 MHz

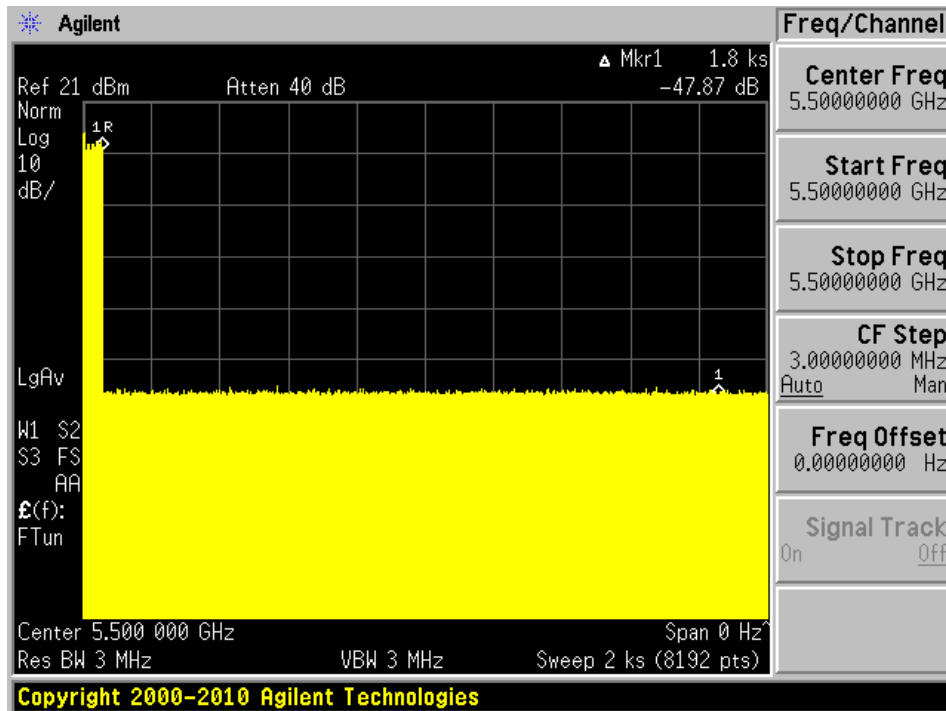

9 Radar Detection Bandwidth & Radar Detection Performance Check

9.1 Detection Bandwidth

Procedure:

Performed with any one of the short pulse radar waveforms type 0

Starting at the center frequency of the UUT operating Channel, increase the radar frequency in 5 MHz steps, repeating the above test sequence, until the detection rate falls below the U-NII Detection Bandwidth criterion specified in Table 4. Repeat this measurement in 1MHz steps at frequencies 5 MHz below where the detection rate begins to fall. Record the highest frequency (denote as FH) at which detection is greater than or equal to the U-NII Detection Bandwidth criterion. Recording the detection rate at frequencies above FH is not required to demonstrate compliance.

Starting at the center frequency of the UUT operating Channel, decrease the radar frequency in 5 MHz steps, repeating the above test sequence, until the detection rate falls below the U-NII Detection Bandwidth criterion specified in Table 4. Repeat this measurement in 1MHz steps at frequencies 5 MHz above where the detection rate begins to fall. Record the lowest frequency (denote as FL) at which detection is greater than or equal to the U-NII Detection Bandwidth criterion. Recording the detection rate at frequencies below FL is not required to demonstrate compliance.

The U-NII Detection Bandwidth is calculated as follows: $\text{U-NII Detection Bandwidth} = \text{FH} - \text{FL}$

Test Results

Frequency (MHz)	F _L (MHz)	F _H (MHz)	Detection Bandwidth (MHz)	Minimum Limit	Result
5280	5270	5290	20	100%	Compliance
5270	5251	5290	39	100%	Compliance
5290	5251	5330	79	100%	Compliance
5250	5250	5330	80	100%	Compliance
5500	5490	5510	20	100%	Compliance
5510	5491	5530	40	100%	Compliance
5530	5490	5570	80	100%	Compliance
5570	5490	5650	160	100%	Compliance

Note: for Channel 5250MHz Bandwidth 160 MHz, the tests performed for transmissions fall within the band 5250MHz to 5350MHz

Please refer to the following tables.

Results of Detection Bandwidth:

EUT Frequency = 5280 MHz											
DFS Detection Trials (1 = Detected, 0 = No Detected)											
Radar Frequency (MHz)	1	2	3	4	5	6	7	8	9	10	Detection Rate (%)
5249	0	0	0	0	0	0	0	0	0	0	0 %
5270(F_L)	1	1	1	1	1	1	1	1	1	1	100 %
5275	1	1	1	1	1	1	1	1	1	1	100 %
5280(F _c)	1	1	1	1	1	1	1	1	1	1	100 %
5285	1	1	1	1	1	1	1	1	1	1	100 %
5290(F_H)	1	1	1	1	1	1	1	1	1	1	100 %
5291	0	0	0	0	0	0	0	0	0	0	0 %
Detection Bandwidth = F_H - F_L=5290-5270=20 MHz											
EUT 99% OBW = 18 MHz; 18 x 100% = 18 MHz						Result:		Pass			

EUT Frequency = 5500 MHz											
DFS Detection Trials (1 = Detected, 0 = No Detected)											
Radar Frequency (MHz)	1	2	3	4	5	6	7	8	9	10	Detection Rate (%)
5489	0	0	0	0	0	0	0	0	0	0	0 %
5490(F_L)	1	1	1	1	1	1	1	1	1	1	100 %
5495	1	1	1	1	1	1	1	1	1	1	100 %
5500(F _c)	1	1	1	1	1	1	1	1	1	1	100 %
5505	1	1	1	1	1	1	1	1	1	1	100 %
5510 (F_H)	1	1	1	1	1	1	1	1	1	1	100 %
5511	0	0	0	0	0	0	0	0	0	0	0 %
Detection Bandwidth = F_H - F_L=5510-5490=20 MHz											
EUT 99% OBW = 18 MHz; 18 x 100% = 18 MHz						Result:		Pass			

Results of Detection Bandwidth:

EUT Frequency = 5270 MHz											
DFS Detection Trials (1 = Detected, 0 = No Detected)											
Radar Frequency (MHz)	1	2	3	4	5	6	7	8	9	10	Detection Rate (%)
5249	0	0	0	0	0	0	0	0	0	0	0 %
5250(F _L)	1	1	1	0	1	0	1	0	0	0	50 %
5251(F_L)	1	1	1	1	1	1	1	1	1	1	100%
5255	1	1	1	1	1	1	1	1	1	1	100 %
5260	1	1	1	1	1	1	1	1	1	1	100 %
5265	1	1	1	1	1	1	1	1	1	1	100 %
5270(F _C)	1	1	1	1	1	1	1	1	1	1	100 %
5275	1	1	1	1	1	1	1	1	1	1	100 %
5280	1	1	1	1	1	1	1	1	1	1	100 %
5285	1	1	1	1	1	1	1	1	1	1	100 %
5290(F_H)	1	1	1	1	1	1	1	1	1	1	100 %
5291	0	0	0	0	0	0	0	0	0	0	0 %
Detection Bandwidth = F_H - F_L=5290-5251=39 MHz											
EUT 99% OBW = 37 MHz; 37 x 100% = 37 MHz						Result:		Pass			

EUT Frequency = 5510 MHz											
DFS Detection Trials (1 = Detected, 0 = No Detected)											
Radar Frequency (MHz)	1	2	3	4	5	6	7	8	9	10	Detection Rate (%)
5489	0	0	0	0	0	0	0	0	0	0	0 %
5490(F_L)	1	1	1	0	1	1	1	1	1	1	90 %
5495	1	1	1	1	1	1	1	1	1	1	100 %
5500	1	1	1	1	1	1	1	1	1	1	100 %
5505	1	1	1	1	1	1	1	1	1	1	100 %
5510(F _C)	1	1	1	1	1	1	1	1	1	1	100 %
5515	1	1	1	1	1	1	1	1	1	1	100 %
5520	1	1	1	1	1	1	1	1	1	1	100 %
5525	1	1	1	1	1	1	1	1	1	1	100 %
5530(F_H)	1	1	1	1	1	1	1	1	1	1	100 %
5531	0	0	0	0	0	0	0	0	0	0	0 %
Detection Bandwidth = F_H - F_L=5530-5490=40 MHz											
EUT 99% OBW = 37 MHz; 37 x 100% = 37 MHz						Result:		Pass			

Results of Detection Bandwidth:

EUT Frequency = 5290 MHz											
DFS Detection Trials (1 = Detected, 0 = No Detected)											
Radar Frequency (MHz)	1	2	3	4	5	6	7	8	9	10	Detection Rate (%)
5249	0	0	0	0	0	0	0	0	0	0	0 %
5250	0	1	1	0	0	0	1	0	0	0	30 %
5251(F_L)	1	1	1	1	1	1	1	1	1	1	100 %
5255	1	1	1	1	1	1	1	1	1	1	100 %
5260	1	1	1	1	1	1	1	1	1	1	100 %
5265	1	1	1	1	1	1	1	1	1	1	100 %
5270	1	1	1	1	1	1	1	1	1	1	100 %
5275	1	1	1	1	1	1	1	1	1	1	100 %
5280	1	1	1	1	1	1	1	1	1	1	100 %
5285	1	1	1	1	1	1	1	1	1	1	100 %
5290(F _C)	1	1	1	1	1	1	1	1	1	1	100 %
5295	1	1	1	1	1	1	1	1	1	1	100 %
5300	1	1	1	1	1	1	1	1	1	1	100 %
5305	1	1	1	1	1	1	1	1	1	1	100 %
5310	1	1	1	1	1	1	1	1	1	1	100 %
5315	1	1	1	1	1	1	1	1	1	1	100 %
5320	1	1	1	1	1	1	1	1	1	1	100 %
5325	1	1	1	1	1	1	1	1	1	1	100 %
5330(F_H)	1	1	1	1	1	1	1	1	1	1	100 %
5331	0	0	0	0	0	0	0	0	0	0	0 %
Detection Bandwidth = F_H – F_L=5330-5251=79 MHz											
EUT 99% OBW = 76 MHz; 76 x 100% = 76 MHz						Result:		Pass			

EUT Frequency = 5530 MHz											
DFS Detection Trials (1 = Detected, 0 = No Detected)											
Radar Frequency (MHz)	1	2	3	4	5	6	7	8	9	10	Detection Rate (%)
5489	0	0	0	0	0	0	0	0	0	0	0 %
5490(F_L)	1	1	1	1	1	1	1	1	1	1	100 %
5495	1	1	1	1	1	1	1	1	1	1	100 %
5500	1	1	1	1	1	1	1	1	1	1	100 %
5505	1	1	1	1	1	1	1	1	1	1	100 %
5510	1	1	1	1	1	1	1	1	1	1	100 %
5515	1	1	1	1	1	1	1	1	1	1	100 %
5520	1	1	1	1	1	1	1	1	1	1	100 %
5525	1	1	1	1	1	1	1	1	1	1	100 %
5530(F _c)	1	1	1	1	1	1	1	1	1	1	100 %
5535	1	1	1	1	1	1	1	1	1	1	100 %
5540	1	1	1	1	1	1	1	1	1	1	100 %
5545	1	1	1	1	1	1	1	1	1	1	100 %
5550	1	1	1	1	1	1	1	1	1	1	100 %
5555	1	1	1	1	1	1	1	1	1	1	100 %
5560	1	1	1	1	1	1	1	1	1	1	100 %
5565	1	1	1	1	1	1	1	1	1	1	100 %
5570(F_H)	1	1	1	1	1	1	1	1	1	1	100 %
5571	0	0	0	0	0	0	0	0	0	0	0 %
Detection Bandwidth = F_H - F_L = 5570 - 5490 = 80 MHz											
EUT 99% OBW = 76 MHz; 76 x 100% = 76 MHz						Result:		Pass			

Results of Detection Bandwidth:

EUT Frequency = 5250 MHz											
DFS Detection Trials (1 = Detected, 0 = No Detected)											
Radar Frequency (MHz)	1	2	3	4	5	6	7	8	9	10	Detection Rate (%)
5249	0	0	0	0	0	0	0	0	0	0	0 %
5250(F_L)	1	1	1	1	1	1	1	1	1	1	100 %
5255	1	1	1	1	1	1	1	1	1	1	100 %
5260	1	1	1	1	1	1	1	1	1	1	100 %
5265	1	1	1	1	1	1	1	1	1	1	100 %
5270	1	1	1	1	1	1	1	1	1	1	100 %
5275	1	1	1	1	1	1	1	1	1	1	100 %
5280	1	1	1	1	1	1	1	1	1	1	100 %
5285	1	1	1	1	1	1	1	1	1	1	100 %
5290(F _C)	1	1	1	1	1	1	1	1	1	1	100 %
5295	1	1	1	1	1	1	1	1	1	1	100 %
5300	1	1	1	1	1	1	1	1	1	1	100 %
5305	1	1	1	1	1	1	1	1	1	1	100 %
5310	1	1	1	1	1	1	1	1	1	1	100 %
5315	1	1	1	1	1	1	1	1	1	1	100 %
5320	1	1	1	1	1	1	1	1	1	1	100 %
5325	1	1	1	1	1	1	1	1	1	1	100 %
5330(F_H)	1	1	1	1	1	1	1	1	1	1	100 %
5331	0	0	0	0	0	0	0	0	0	0	0 %
Detection Bandwidth = F_H - F_L = 5330 - 5250 = 80 MHz											
EUT 99% OBW = 76 MHz; 76 x 100% = 76 MHz Result: Pass											

Note: for Channel 5250MHz Bandwidth 160 MHz, the tests performed for transmissions fall within the band 5250MHz to 5350MHz

EUT Frequency = 5570 MHz											
DFS Detection Trials (1 = Detected, 0 = No Detected)											
Radar Frequency (MHz)	1	2	3	4	5	6	7	8	9	10	Detection Rate (%)
5489	0	0	0	0	0	0	0	0	0	0	0 %
5490(F_L)	1	1	1	1	1	1	0	1	1	1	90 %
5491	1	1	1	1	1	1	0	1	1	1	100 %
5495	1	1	1	1	1	1	1	1	1	1	100 %
5500	1	1	1	1	1	1	1	1	1	1	100 %
5505	1	1	1	1	1	1	1	1	1	1	100 %
5510	1	1	1	1	1	1	1	1	1	1	100 %
5515	1	1	1	1	1	1	1	1	1	1	100 %
5520	1	1	1	1	1	1	1	1	1	1	100 %
5525	1	1	1	1	1	1	1	1	1	1	100 %
5530	1	1	1	1	1	1	1	1	1	1	100 %
5535	1	1	1	1	1	0	1	1	1	1	90 %
5540	1	1	0	1	1	1	1	1	1	1	90 %
5545	1	1	1	1	1	1	1	1	1	1	100 %
5550	1	1	1	1	1	1	1	1	1	1	100 %
5555	1	1	1	1	1	1	1	1	1	1	100 %
5560	1	1	1	1	1	1	1	1	1	1	100 %
5565	1	1	1	1	1	1	1	1	1	1	100 %
5570(F _C)	1	1	1	1	1	1	1	1	1	1	100 %
5575	1	1	1	1	1	1	1	1	1	1	100 %
5580	1	1	1	1	1	1	1	1	1	1	100 %
5585	1	1	1	1	1	1	1	1	1	1	100 %
5590	1	1	1	1	1	1	1	1	1	1	100 %
5595	1	1	1	1	1	1	1	1	1	1	100 %
5600	1	1	1	1	1	1	1	1	1	1	100 %
5605	1	1	1	1	1	1	1	1	1	1	100 %
5610	1	1	1	1	1	1	1	1	1	1	100 %
5615	1	1	1	1	1	1	1	1	1	1	100 %
5620	1	1	1	1	1	1	1	1	1	1	100 %
5625	1	1	1	1	1	1	1	1	1	1	100 %
5630	1	1	1	1	1	1	1	1	1	1	100 %
5635	1	1	1	1	1	1	1	1	1	1	100 %
5640	1	1	1	1	1	1	1	1	1	1	100 %
5645	1	1	1	1	1	1	1	1	1	1	100 %
5650(F_H)	1	1	1	1	1	1	1	1	1	1	100 %
5651	0	0	0	0	0	0	0	0	0	0	0 %
Detection Bandwidth = F_H - F_L=5650-5490=160 MHz											
EUT 99% OBW = 152 MHz; 152 x 100% = 156 MHz						Result:		Pass			

9.2 Radar Detection Performance Check

Procedure:

Stream MPEG file from master to slave

Generate radar waveform

Record whether or not the waveform was detected

At least 30 trials are applied for each radar type

For radar types with randomized parameters, each trial uses a unique waveform

Perform with each of the radar types 1-6

Confirm that the detection rate for each radar type meets the minimum requirement

Type 1A&1B, 2, 3, 4: 60% each

Type 5: 80%

Type 6: 70%

Confirm that the mean of the rates for radar types 1 through 4 meets the requirement of 80%

$$\text{Detection Ratio} = \frac{\text{Total Waveform Detections}}{\text{Total Waveform Trials}} \times 100$$

Test Results:

Please refer to the following summary table.

5280 MHz, 20 MHz Bandwidth

Radar Signal Type	Waveform/Trial Number	Detection (%)	Limit (%)	Pass/Fail
Type 1A/1B	30	96.67	60%	Pass
Type 2	30	100	60%	Pass
Type 3	30	100	60%	Pass
Type 4	30	96.67	60%	Pass
Aggregate (Type1 to 4)	120	98.33	80%	Pass
Type 5	30	90	80%	Pass
Type 6	30	86.67	70%	Pass

Please refer to Section A.1 of Appendix A for the radar parameter data sheet.

5270 MHz, 40 MHz Bandwidth

Radar Signal Type	Waveform/Trial Number	Detection (%)	Limit (%)	Pass/Fail
Type 1A/1B	30	90	60%	Pass
Type 2	30	100	60%	Pass
Type 3	30	93.33	60%	Pass
Type 4	30	100	60%	Pass
Aggregate (Type1 to 4)	120	95.83	80%	Pass
Type 5	30	86.67	80%	Pass
Type 6	30	100	70%	Pass

Please refer to Section A.2 of Appendix A for the radar parameter data sheet.

5290 MHz, 80 MHz Bandwidth

Radar Signal Type	Waveform/Trial Number	Detection (%)	Limit (%)	Pass/Fail
Type 1A/1B	30	96.67	60%	Pass
Type 2	30	90	60%	Pass
Type 3	30	96.67	60%	Pass
Type 4	30	96.67	60%	Pass
Aggregate (Type1 to 4)	120	95	80%	Pass
Type 5	30	90	80%	Pass
Type 6	30	96.67	70%	Pass

Please refer to Section A.3 of Appendix A for the radar parameter data sheet.

5250 MHz, 160 MHz Bandwidth

Radar Signal Type	Waveform/Trial Number	Detection (%)	Limit (%)	Pass/Fail
Type 1A/1B	30	100	60%	Pass
Type 2	30	100	60%	Pass
Type 3	30	100	60%	Pass
Type 4	30	100	60%	Pass
Aggregate (Type1 to 4)	120	100	80%	Pass
Type 5	30	93.33	80%	Pass
Type 6	30	96.67	70%	Pass

Note: for Channel 5250MHz Bandwidth 160 MHz, the tests performed for transmissions fall within the band 5250MHz to 5350MHz

Please refer to Section A.4 of Appendix A for the radar parameter data sheet.

5500 MHz, 20 MHz Bandwidth

Radar Signal Type	Waveform/Trial Number	Detection (%)	Limit (%)	Pass/Fail
Type 1A/1B	30	93.33	60%	Pass
Type 2	30	96.67	60%	Pass
Type 3	30	93.33	60%	Pass
Type 4	30	96.67	60%	Pass
Aggregate (Type1 to 4)	120	95	80%	Pass
Type 5	30	93.33	80%	Pass
Type 6	30	96.67	70%	Pass

Please refer to Section B.1 of Appendix B for the radar parameter data sheet.

5510 MHz, 40 MHz Bandwidth

Radar Signal Type	Waveform/Trial Number	Detection (%)	Limit (%)	Pass/Fail
Type 1A/1B	30	96.67	60%	Pass
Type 2	30	100	60%	Pass
Type 3	30	100	60%	Pass
Type 4	30	100	60%	Pass
Aggregate (Type1 to 4)	120	99.17	80%	Pass
Type 5	30	100	80%	Pass
Type 6	30	100	70%	Pass

Please refer to Section B.2 of Appendix B for the radar parameter data sheet.

5530 MHz, 80 MHz Bandwidth

Radar Signal Type	Waveform/Trial Number	Detection (%)	Limit (%)	Pass/Fail
Type 1A/1B	30	100	60%	Pass
Type 2	30	93.33	60%	Pass
Type 3	30	93.33	60%	Pass
Type 4	30	96.67	60%	Pass
Aggregate (Type1 to 4)	120	95.83	80%	Pass
Type 5	30	100	80%	Pass
Type 6	30	100	70%	Pass

Please refer to Section B.3 of Appendix B for the radar parameter data sheet.

5570 MHz, 160 MHz Bandwidth

Radar Signal Type	Waveform/Trial Number	Detection (%)	Limit (%)	Pass/Fail
Type 1A/1B	30	100	60%	Pass
Type 2	30	100	60%	Pass
Type 3	30	83.33	60%	Pass
Type 4	30	80	60%	Pass
Aggregate (Type1 to 4)	120	90.83	80%	Pass
Type 5	30	100	80%	Pass
Type 6	30	100	70%	Pass

Please refer to Section B.4 of Appendix B for the radar parameter data sheet.

10 Appendix A (Normative) - U-NII-2A Radar Parameter Data Sheet

Please refer to the attachment.

11 Appendix B (Normative) - U-NII-2C Radar Parameter Data Sheet

Please refer to the attachment.

12 Appendix C (Normative) - DFS Test Setup Photo

Please refer to the attachment.

13 Appendix D (Normative) - A2LA Electrical Testing Certificate



Accredited Laboratory

A2LA has accredited

BAY AREA COMPLIANCE LABORATORIES CORP.

Sunnyvale, CA

for technical competence in the field of

Electrical Testing

This laboratory is accredited in accordance with the recognized International Standard ISO/IEC 17025:2005 General requirements for the competence of testing and calibration laboratories. This laboratory also meets A2LA R222 - Specific Requirements EPA ENERGY STAR Accreditation Program. This accreditation demonstrates technical competence for a defined scope and the operation of a laboratory quality management system (refer to joint ISO-ILAC-IAF Communiqué dated April 2017).



Presented this 2nd day of October 2018.

President and CEO
For the Accreditation Council
Certificate Number 3297.02
Valid to September 30, 2020

For the tests to which this accreditation applies, please refer to the laboratory's Electrical Scope of Accreditation.

Please follow the web link below for a full ISO 17025 scope

<https://portal.a2la.org/scopepdf/3297-02.pdf>

--- END OF REPORT ---

Appendix A – U-NII-2A Radar Parameter Data Sheet

A.1 20 MHz Bandwidth @ 5280 MHz

Table-1A/1B Radar Type 1A/1B Statistical Performance

Trial #	Fc (MHz)	Pulse/Burst	Pulse Width (μS)	PRI (μs)	Detection (1:yes; 0:no)
1	5270	59	1	898	1
2	5270	95	1	558	1
3	5270	58	1	918	1
4	5270	61	1	878	1
5	5270	72	1	738	1
6	5280	74	1	718	1
7	5280	57	1	938	1
8	5280	81	1	658	1
9	5280	62	1	858	1
10	5280	102	1	518	1
11	5290	65	1	818	1
12	5290	83	1	638	1
13	5290	89	1	598	1
14	5290	63	1	838	1
15	5290	68	1	778	1
16	5270	21	1	2542	1
17	5270	22	1	2435	1
18	5270	25	1	2128	1
19	5270	20	1	2650	1
20	5270	21	1	2526	0
21	5280	29	1	1883	1
22	5280	18	1	3058	1
23	5280	19	1	2836	1
24	5280	18	1	3015	1
25	5280	28	1	1894	1
26	5290	19	1	2911	1
27	5290	51	1	1045	1
28	5290	33	1	1627	1
29	5290	42	1	1260	1
30	5290	23	1	2333	1
Detection Percentage: 96.67 % (>60%)					

Table-2 Radar Type 2 Statistical Performance

Trial #	Fc (MHz)	Pulse/Burst	Pulse Width (μ S)	PRI (μ s)	Detection (1:yes; 0:no)
1	5270	24	2	168	1
2	5270	29	1.3	186	1
3	5270	23	3.8	186	1
4	5270	25	1.4	184	1
5	5270	23	2.2	155	1
6	5270	28	1.2	177	1
7	5270	25	4.3	205	1
8	5270	23	2.4	192	1
9	5270	24	3.6	223	1
10	5270	25	1.8	213	1
11	5280	23	1.9	161	1
12	5280	25	3.1	192	1
13	5280	27	1.7	160	1
14	5280	28	4.3	161	1
15	5280	28	4.9	226	1
16	5280	24	1.1	164	1
17	5280	27	4.9	180	1
18	5280	27	2.7	222	1
19	5280	29	2.6	175	1
20	5280	26	3.9	223	1
21	5290	25	3.4	227	1
22	5290	27	1.6	200	1
23	5290	27	2.2	225	1
24	5290	24	1.3	186	1
25	5290	29	2.9	207	1
26	5290	23	4.1	219	1
27	5290	28	5	202	1
28	5290	27	4.1	168	1
29	5290	29	2	211	1
30	5290	27	2.9	178	1
Detection Percentage: 100 % (>60%)					

Table-3 Radar Type 3 Statistical Performance

Trial #	Fc (MHz)	Pulse/Burst	Pulse Width (μS)	PRI (μs)	Detection (1:yes; 0:no)
1	5270	16	8.3	477	1
2	5270	16	6.5	240	1
3	5270	17	6.3	414	1
4	5270	16	9.4	282	1
5	5270	17	7.7	298	1
6	5270	16	6.1	249	1
7	5270	18	8.1	332	1
8	5270	18	8.6	287	1
9	5270	16	10	427	1
10	5270	17	6.2	399	1
11	5280	16	6.1	340	1
12	5280	17	6.6	279	1
13	5280	17	8.5	430	1
14	5280	17	9.2	228	1
15	5280	18	9.9	246	1
16	5280	16	7.8	329	1
17	5280	17	10	361	1
18	5280	16	10	478	1
19	5280	16	8.5	278	1
20	5280	18	9.5	299	1
21	5290	16	7.3	247	1
22	5290	18	6.1	216	1
23	5290	18	9.9	284	1
24	5290	18	8.3	451	1
25	5290	18	9	355	1
26	5290	16	9.2	305	1
27	5290	16	6	456	1
28	5290	18	8.8	345	1
29	5290	18	6.2	358	1
30	5290	18	6.8	283	1
Detection Percentage: 100 % (>60%)					

Table-4 Radar Type 4 Statistical Performance

Trial #	Fc (MHz)	Pulse/Burst	Pulse Width (µS)	PRI (µs)	Detection (1:yes; 0:no)
1	5270	16	18.1	287	1
2	5270	14	13.4	334	1
3	5270	12	14.6	247	1
4	5270	13	17.4	308	1
5	5270	12	12.4	407	1
6	5270	15	16.5	306	1
7	5270	13	16.9	336	1
8	5270	15	16	420	1
9	5270	14	13.3	239	1
10	5270	13	16	363	1
11	5280	12	17.1	316	1
12	5280	13	18.7	248	1
13	5280	13	18.7	277	1
14	5280	14	15.3	345	1
15	5280	16	13.6	366	1
16	5280	13	19.1	272	1
17	5280	16	16.5	432	1
18	5280	15	14.4	396	1
19	5280	14	12.8	219	1
20	5280	12	12.4	355	1
21	5290	16	19.4	451	1
22	5290	13	13.7	256	1
23	5290	14	18.5	464	0
24	5290	14	18.5	491	1
25	5290	15	12	222	1
26	5290	12	13.6	320	1
27	5290	13	11.3	419	1
28	5290	12	11.8	324	1
29	5290	14	17.7	247	1
30	5290	14	15.5	466	1
Detection Percentage: 96.67 % (>60%)					

Table-5 Radar Type 5 Statistical Performance

Trial #	Fc (MHz)	Detection (1:yes; 0:no)
1	5280	1
2	5280	1
3	5280	1
4	5280	1
5	5280	1
6	5280	1
7	5280	1
8	5280	1
9	5280	1
10	5280	1
11	5277.8	0
12	5273.4	1
13	5276.2	1
14	5274.2	1
15	5275.8	0
16	5273.4	1
17	5276.2	1
18	5275.0	1
19	5273.4	1
20	5277.4	0
21	5287.2	1
22	5284.0	1
23	5286.8	1
24	5282.8	1
25	5283.2	1
26	5283.6	1
27	5282.0	1
28	5282.4	1
29	5285.2	1
30	5283.6	1
Detection Percentage: 90 % (>80%)		

Bin5 Statistics 1

Trial #	Pulse	Chirp (MHz)	Pulse Width (µS)	Pulse 1-2 spacing (µS)	Pulse 2-3 spacing (µS)	Pulse Start(S)	Detection (1:yes; 0:no)
0	3	12	57.9	1504	1257	0.015809	1
1	2	12	64.7	1356		1.261577	
2	2	12	57.1	1369		2.059656	
3	2	12	98.2	1151		2.992105	
4	3	12	81.4	1315	1395	3.275026	
5	3	12	78.3	1431	1575	3.986453	
6	1	12	85.6			4.536644	
7	2	12	85.9	1089		5.325495	
8	2	12	51.8	1609		6.512832	
9	2	12	97	1830		7.038323	
10	2	12	78.5	1026		7.933653	
11	3	12	57.5	1942	1211	8.72416	
12	3	12	84.8	1707	1690	9.027488	
13	1	12	76.4			10.390056	
14	1	12	76.5			11.213038	
15	1	12	85.8			11.979937	

Bin5 Statistics 2

Trial #	Pulse	Chirp (MHz)	Pulse Width (µS)	Pulse 1-2 spacing (µS)	Pulse 2-3 spacing (µS)	Pulse Start(S)	Detection (1:yes; 0:no)
0	2	14	50.8	1533		0.534911	1
1	3	14	53.1	1334	1572	1.619589	
2	1	14	87.4			1.900886	
3	2	14	76.7	1407		2.918127	
4	2	14	60.7	1600		4.011408	
5	3	14	86.2	1900	1361	5.067464	
6	1	14	97.3			5.422982	
7	2	14	93.7	1061		6.490543	
8	3	14	91.7	1074	1756	7.343484	
9	3	14	66.4	1024	1217	8.335262	
10	2	14	91.4	1230		8.979538	
11	2	14	82.1	1685		9.796255	
12	1	14	89.4			10.662779	
13	2	14	76.2	1101		11.482744	

Bin5 Statistics 3

Trial #	Pulse	Chirp (MHz)	Pulse Width (µS)	Pulse 1-2 spacing (µS)	Pulse 2-3 spacing (µS)	Pulse Start(S)	Detection (1:yes; 0:no)
0	2	12	55.2	1780		1.159613	1
1	1	12	58.7			1.618673	
2	3	12	92.7	1264	1780	3.470628	
3	2	12	73.1	1812		4.493886	
4	2	12	59.1	1267		5.803152	
5	1	12	56.7			7.714587	
6	2	12	59.5	1068		8.803794	
7	3	12	72.9	1254	1559	10.653566	
8	2	12	94.7	1061		10.681022	

Bin5 Statistics 4

Trial #	Pulse	Chirp (MHz)	Pulse Width (µS)	Pulse 1-2 spacing (µS)	Pulse 2-3 spacing (µS)	Pulse Start(S)	Detection (1:yes; 0:no)
0	1	11	65.3			0.448083	1
1	2	11	65.9	1698		0.942497	
2	2	11	97.6	1017		1.576142	
3	2	11	60.2	1419		2.388992	
4	2	11	55.7	1414		2.961849	
5	1	11	72.4			3.894638	
6	1	11	54.1			4.595182	
7	3	11	98.6	1651	1287	4.896041	
8	1	11	98.8			5.387336	
9	1	11	55.5			6.077495	
10	2	11	79.3	1312		6.849961	
11	2	11	95.4	1532		7.472388	
12	2	11	93.6	1041		8.31806	
13	3	11	86.3	1125	1057	8.692336	
14	3	11	58	1023	1230	9.753792	
15	1	11	78.3			10.591461	
16	1	11	73.5			10.857642	
17	2	11	85.3	1065		11.62901	

Bin5 Statistics 5

Trial #	Pulse	Chirp (MHz)	Pulse Width (µS)	Pulse 1-2 spacing (uS)	Pulse 2-3 spacing (uS)	Pulse Start(S)	Detection (1:yes; 0:no)
0	2	8	67.4	1131		0.153579	1
1	2	8	60.2	1878		2.162808	
2	3	8	76.4	1725	1068	2.494025	
3	2	8	56.5	1863		3.644944	
4	2	8	88	1885		5.806165	
5	1	8	56.9			6.614299	
6	3	8	64.4	1057	1755	7.318325	
7	2	8	59.6	1065		8.432324	
8	3	8	59.7	1814	1003	10.324183	
9	2	8	95.2	1153		10.91763	

Bin5 Statistics 6

Trial #	Pulse	Chirp (MHz)	Pulse Width (µS)	Pulse 1-2 spacing (uS)	Pulse 2-3 spacing (uS)	Pulse Start(S)	Detection (1:yes; 0:no)
0	2	8	73	1065		0.556158	1
1	2	8	83.8	1449		1.779147	
2	1	8	67.5			2.391571	
3	2	8	58.5	1533		3.267607	
4	3	8	74.4	1111	1713	4.481591	
5	1	8	60.1			5.228603	
6	1	8	56.2			6.019013	
7	2	8	98	1153		7.318405	
8	2	8	95.4	1403		7.677229	
9	2	8	65.3	1305		9.071694	
10	3	8	79.9	1946	1443	9.361822	
11	3	8	67.4	1278	1138	10.533099	
12	2	8	57.2	1413		11.455716	

Bin5 Statistics 7

Trial #	Pulse	Chirp (MHz)	Pulse Width (µS)	Pulse 1-2 spacing (µS)	Pulse 2-3 spacing (µS)	Pulse Start(S)	Detection (1:yes; 0:no)
0	2	11	91.7	1186		0.090635	1
1	1	11	69.1			0.791579	
2	2	11	62.7	1082		1.460231	
3	3	11	82.9	1938	1379	2.360129	
4	1	11	74			3.170693	
5	2	11	79.7	1919		3.673139	
6	3	11	62.8	1847	1512	4.693801	
7	3	11	82.2	1947	1083	5.268552	
8	1	11	71			6.042191	
9	3	11	66.2	1321	1123	6.76166	
10	2	11	69	1225		7.64934	
11	1	11	96.4			8.126064	
12	3	11	74.9	1184	1259	9.054907	
13	1	11	83.1			9.833106	
14	3	11	67.7	1140	1934	9.891716	
15	1	11	90.1			10.951888	
16	2	11	93.2	1684		11.667484	

Bin5 Statistics 8

Trial #	Pulse	Chirp (MHz)	Pulse Width (µS)	Pulse 1-2 spacing (µS)	Pulse 2-3 spacing (µS)	Pulse Start(S)	Detection (1:yes; 0:no)
0	3	14	91.3	1325	1113	0.735943	1
1	1	14	71			1.390564	
2	2	14	71.1	1533		1.517118	
3	3	14	86.7	1012	1397	2.969048	
4	2	14	70.3	1013		3.451926	
5	3	14	63.5	1275	1079	4.157325	
6	1	14	57			4.520135	
7	1	14	71.7			5.534141	
8	1	14	86.9			6.028084	
9	2	14	80.4	1211		6.833898	
10	1	14	81.4			8.173773	
11	1	14	66.1			8.859864	
12	3	14	67.5	1610	1636	9.031597	
13	2	14	78.9	1541		10.023057	
14	2	14	88.4	1507		10.529107	
15	3	14	75.4	1555	1394	11.904106	

Bin5 Statistics 9

Trial #	Pulse	Chirp (MHz)	Pulse Width (µS)	Pulse 1-2 spacing (uS)	Pulse 2-3 spacing (uS)	Pulse Start(S)	Detection (1:yes; 0:no)
0	2	6	75.1	1425		0.703165	1
1	1	6	67.9			1.519827	
2	1	6	70.7			2.275239	
3	2	6	97.6	1111		2.796425	
4	1	6	92.4			3.861694	
5	2	6	72.2	1476		4.914299	
6	3	6	83.8	1741	1224	5.953166	
7	2	6	59	1602		7.160918	
8	1	6	81.3			8.067904	
9	1	6	56.9			9.116291	
10	2	6	64.9	1732		9.548481	
11	2	6	99.5	1836		10.63203	
12	2	6	80.3	1289		11.844075	

Bin5 Statistics 10

Trial #	Pulse	Chirp (MHz)	Pulse Width (µS)	Pulse 1-2 spacing (uS)	Pulse 2-3 spacing (uS)	Pulse Start(S)	Detection (1:yes; 0:no)
0	1	12	53.2			0.448737	1
1	3	12	87.7	1854	1943	0.985641	
2	1	12	75.9			1.56209	
3	3	12	69.4	1989	1901	2.193569	
4	1	12	93.2			3.029878	
5	2	12	67.3	1397		4.184411	
6	1	12	69.2			4.857445	
7	1	12	92.7			5.255867	
8	1	12	96.7			6.229534	
9	2	12	70.4	1851		6.980085	
10	2	12	83.9	1088		7.155245	
11	2	12	77	1132		7.823255	
12	3	12	76.5	1178	1796	9.163006	
13	2	12	82.4	1251		9.747263	
14	2	12	88.6	1130		10.329615	
15	2	12	88.8	1488		10.912854	
16	3	12	78	1119	1580	11.817488	

Bin5 Statistics 11

Trial #	Pulse	Chirp (MHz)	Pulse Width (µS)	Pulse 1-2 spacing (uS)	Pulse 2-3 spacing (uS)	Pulse Start(S)	Detection (1:yes; 0:no)
0	2	17	75.5	1152		0.075263	0
1	3	17	62.4	1426	1742	0.830958	
2	3	17	59.7	1516	1467	1.936474	
3	3	17	51.9	1394	1688	2.524031	
4	1	17	83.4			3.595815	
5	2	17	92.4	1563		4.022413	
6	3	17	53.7	1265	1344	5.128706	
7	3	17	59.6	1369	1856	5.882331	
8	2	17	99.6	1338		6.04881	
9	2	17	99.4	1271		7.028951	
10	2	17	51.4	1182		7.579702	
11	1	17	69.5			8.735958	
12	1	17	68			9.371644	
13	3	17	91.5	1111	1844	10.270757	
14	3	17	87.6	1050	1245	11.11686	
15	2	17	58.9	1025		11.881182	

Bin5 Statistics 12

Trial #	Pulse	Chirp (MHz)	Pulse Width (µS)	Pulse 1-2 spacing (uS)	Pulse 2-3 spacing (uS)	Pulse Start(S)	Detection (1:yes; 0:no)
0	2	6	59	1735		0.182171	1
1	2	6	67	1669		1.191174	
2	2	6	91.4	1524		1.699269	
3	1	6	61			2.371134	
4	2	6	94.7	1619		2.750977	
5	1	6	51.7			3.225184	
6	1	6	55.1			3.838268	
7	2	6	60.9	1864		4.734952	
8	2	6	69.4	1097		5.268255	
9	2	6	58.7	1626		5.707803	
10	3	6	88.1	1337	1427	6.533485	
11	2	6	94.3	1031		6.746659	
12	3	6	79.3	1899	1038	7.456365	
13	2	6	69.5	1338		8.154884	
14	1	6	69.8			8.792832	
15	2	6	51.8	1074		9.381911	
16	1	6	74.8			9.905288	
17	2	6	96.5	1411		10.362851	
18	1	6	92.9			10.91396	
19	1	6	78.9			11.752393	

Bin5 Statistics 13

Trial #	Pulse	Chirp (MHz)	Pulse Width (µS)	Pulse 1-2 spacing (uS)	Pulse 2-3 spacing (uS)	Pulse Start(S)	Detection (1:yes; 0:no)
0	1	13	57.4			0.015754	1
1	2	13	60.1	1054		1.350699	
2	3	13	60.1	1743	1937	2.772934	
3	2	13	87.5	1886		4.034761	
4	2	13	55.1	1895		5.114185	
5	3	13	57.6	1617	1146	6.4108	
6	3	13	74.4	1506	1032	8.002104	
7	2	13	81.4	1599		9.372758	
8	2	13	64.1	1687		9.686936	
9	2	13	87.5	1501		11.326653	

Bin5 Statistics 14

Trial #	Pulse	Chirp (MHz)	Pulse Width (µS)	Pulse 1-2 spacing (µS)	Pulse 2-3 spacing (µS)	Pulse Start(S)	Detection (1:yes; 0:no)
0	2	8	90.1	1980		0.123296	1
1	1	8	98			1.614999	
2	1	8	65.6			2.850108	
3	3	8	58.6	1127	1937	3.776121	
4	2	8	66.8	1709		4.560784	
5	2	8	93.7	1655		5.54374	
6	2	8	60.6	1239		6.472064	
7	2	8	95.9	1304		7.038755	
8	2	8	90.7	1972		8.41134	
9	3	8	62.8	1086	1357	9.388451	
10	1	8	95.4			10.766865	
11	1	8	90			11.677564	

Bin5 Statistics 15

Trial #	Pulse	Chirp (MHz)	Pulse Width (µS)	Pulse 1-2 spacing (µS)	Pulse 2-3 spacing (µS)	Pulse Start(S)	Detection (1:yes; 0:no)
0	2	12	51.9	1366		0.270828	0
1	3	12	83.2	1848	1042	0.671964	
2	3	12	85	1259	1068	1.644619	
3	1	12	78.4			1.964174	
4	1	12	51.9			3.149707	
5	2	12	72.3	1001		3.643535	
6	1	12	50.3			4.388086	
7	1	12	93.7			4.963049	
8	1	12	50.4			5.337024	
9	2	12	83.8	1450		6.052144	
10	2	12	55.9	1195		6.703049	
11	2	12	86.6	1844		7.059311	
12	1	12	94.8			8.129702	
13	3	12	58.6	1132	1347	8.796095	
14	3	12	76.6	1061	1019	9.189469	
15	2	12	56.6	1145		9.702783	
16	1	12	58.7			10.161677	
17	2	12	71.4	1319		11.20877	
18	2	12	78.5	1267		11.38031	

Bin5 Statistics 16

Trial #	Pulse	Chirp (MHz)	Pulse Width (µS)	Pulse 1-2 spacing (uS)	Pulse 2-3 spacing (uS)	Pulse Start(S)	Detection (1:yes; 0:no)
0	2	6	83.9	1079		0.659868	1
1	3	6	91.9	1445	1140	1.912892	
2	3	6	55.5	1202	1454	3.788626	
3	2	6	68.3	1179		4.126508	
4	2	6	66.2	1367		5.992566	
5	2	6	56.1	1149		7.96109	
6	2	6	76.9	1919		8.407417	
7	3	6	73.8	1617	1063	9.765561	
8	1	6	86.5			11.401623	

Bin5 Statistics 17

Trial #	Pulse	Chirp (MHz)	Pulse Width (µS)	Pulse 1-2 spacing (uS)	Pulse 2-3 spacing (uS)	Pulse Start(S)	Detection (1:yes; 0:no)
0	1	13	75.6			0.87461	1
1	3	13	93.1	1926	1048	1.475195	
2	2	13	97.9	1864		3.434095	
3	3	13	60.2	1750	1060	3.608222	
4	2	13	69.8	1151		5.447154	
5	1	13	73.2			6.495849	
6	2	13	83.3	1592		8.164151	
7	1	13	93.1			8.933353	
8	2	13	50.4	1597		9.917959	
9	3	13	81.9	1636	1970	11.894018	

Bin5 Statistics 18

Trial #	Pulse	Chirp (MHz)	Pulse Width (µS)	Pulse 1-2 spacing (µS)	Pulse 2-3 spacing (µS)	Pulse Start(S)	Detection (1:yes; 0:no)
0	3	10	73.5	1979	1261	0.057436	1
1	2	10	88.4	1282		1.144306	
2	2	10	61.4	1746		2.359478	
3	2	10	93.2	1096		2.558587	
4	2	10	50.4	1991		3.688859	
5	1	10	60			4.261726	
6	1	10	100			4.996295	
7	1	10	79.5			6.38999	
8	3	10	60.9	1039	1251	6.685857	
9	2	10	85.8	1016		7.381161	
10	2	10	67.2	1869		8.779679	
11	2	10	71	1210		9.472029	
12	2	10	99.4	1812		10.207429	
13	2	10	73.2	1993		11.190235	
14	2	10	61.8	1866		11.699328	

Bin5 Statistics 19

Trial #	Pulse	Chirp (MHz)	Pulse Width (µS)	Pulse 1-2 spacing (µS)	Pulse 2-3 spacing (µS)	Pulse Start(S)	Detection (1:yes; 0:no)
0	3	6	94.8	1785	1420	0.793507	1
1	2	6	75.5	1807		1.05986	
2	1	6	88.8			1.72584	
3	3	6	92.2	1055	1408	3.419593	
4	2	6	81.6	1378		4.190676	
5	2	6	70.6	1839		4.549782	
6	2	6	74.4	1041		5.907616	
7	2	6	53	1430		6.143769	
8	2	6	93.2	1652		7.205971	
9	2	6	66.7	1482		8.370804	
10	1	6	73.1			9.274992	
11	3	6	96.5	1906	1344	9.571909	
12	2	6	91	1711		10.309385	
13	1	6	75.9			11.218809	

Bin5 Statistics 20

Trial #	Pulse	Chirp (MHz)	Pulse Width (µS)	Pulse 1-2 spacing (uS)	Pulse 2-3 spacing (uS)	Pulse Start(S)	Detection (1:yes; 0:no)
0	1	16	74.3			0.682412	0
1	2	16	70.3	1554		1.419139	
2	1	16	59.5			2.251198	
3	2	16	59.4	1058		3.619705	
4	3	16	98	1446	1519	4.017059	
5	1	16	92.8			5.084059	
6	2	16	60.2	1363		5.974949	
7	2	16	85.4	1812		6.712924	
8	3	16	76.6	1971	1586	7.571433	
9	1	16	86.2			8.524803	
10	1	16	58.2			9.754415	
11	2	16	54.1	1316		10.510734	
12	2	16	56.3	1500		11.907376	

Bin5 Statistics 21

Trial #	Pulse	Chirp (MHz)	Pulse Width (µS)	Pulse 1-2 spacing (uS)	Pulse 2-3 spacing (uS)	Pulse Start(S)	Detection (1:yes; 0:no)
0	2	7	95.5	1647		1.063286	1
1	2	7	68.2	1487		2.91473	
2	2	7	50.8	1482		3.123951	
3	1	7	73.4			5.926736	
4	2	7	86.6	1032		6.82955	
5	3	7	98.9	1794	1119	8.253279	
6	1	7	77.6			9.588427	
7	1	7	98.8			11.735555	

Bin5 Statistics 22

Trial #	Pulse	Chirp (MHz)	Pulse Width (µS)	Pulse 1-2 spacing (µS)	Pulse 2-3 spacing (µS)	Pulse Start(S)	Detection (1:yes; 0:no)
0	1	15	85.4			0.720275	1
1	1	15	51.2			1.418686	
2	3	15	54.7	1305	1291	2.293707	
3	2	15	50.9	1192		3.945714	
4	2	15	51.5	1373		4.398339	
5	2	15	83.5	1747		5.248163	
6	2	15	70.3	1014		6.034334	
7	2	15	74.1	1559		7.460915	
8	3	15	57.2	1475	1155	8.692691	
9	2	15	64.8	1331		9.165827	
10	2	15	79.2	1661		10.596456	
11	3	15	93.2	1037	1710	11.047544	

Bin5 Statistics 23

Trial #	Pulse	Chirp (MHz)	Pulse Width (µS)	Pulse 1-2 spacing (µS)	Pulse 2-3 spacing (µS)	Pulse Start(S)	Detection (1:yes; 0:no)
0	3	8	74.2	1316	1198	0.07793	1
1	2	8	75.2	1448		1.279918	
2	2	8	53	1008		1.991505	
3	3	8	79.1	1895	1147	2.609964	
4	2	8	59.5	1863		3.273305	
5	1	8	94			4.156565	
6	1	8	80			4.538602	
7	2	8	55.4	1110		5.49667	
8	2	8	50.2	1175		5.989609	
9	2	8	52.5	1313		6.615572	
10	2	8	86.9	1460		7.076418	
11	3	8	52.6	1451	1401	8.384774	
12	2	8	60.6	1878		8.641347	
13	2	8	85.6	1826		9.183314	
14	1	8	57.7			10.11272	
15	2	8	75.3	1761		11.251871	
16	3	8	79.9	1476	1599	11.305114	

Bin5 Statistics 24

Trial #	Pulse	Chirp (MHz)	Pulse Width (µS)	Pulse 1-2 spacing (µS)	Pulse 2-3 spacing (µS)	Pulse Start(S)	Detection (1:yes; 0:no)
0	3	18	51	1249	1127	0.402937	1
1	2	18	77.7	1021		1.110154	
2	1	18	74.2			1.366336	
3	3	18	75.4	1539	1749	2.478502	
4	2	18	98	1217		3.211718	
5	3	18	69.5	1723	1673	3.727895	
6	2	18	53.7	1286		4.176288	
7	1	18	84			5.032341	
8	3	18	58.4	1364	1231	5.882498	
9	3	18	99.5	1914	1478	6.3374	
10	2	18	86.7	1949		7.048471	
11	2	18	99.2	1468		7.497768	
12	2	18	68	1230		8.275091	
13	2	18	56.7	1920		8.907183	
14	2	18	56.2	1768		9.586354	
15	2	18	84.6	1876		10.352676	
16	3	18	70.9	1097	1574	11.223028	
17	2	18	76.8	1401		11.820288	

Bin5 Statistics 25

Trial #	Pulse	Chirp (MHz)	Pulse Width (µS)	Pulse 1-2 spacing (µS)	Pulse 2-3 spacing (µS)	Pulse Start(S)	Detection (1:yes; 0:no)
0	2	17	71	1375		0.212175	1
1	1	17	96.9			0.864869	
2	3	17	74.3	1055	1077	1.283741	
3	2	17	55.4	1966		2.050908	
4	1	17	82.7			2.705701	
5	1	17	56.2			3.340782	
6	2	17	90.2	1071		4.016557	
7	2	17	87.8	1119		4.565663	
8	2	17	77.4	1793		5.131968	
9	3	17	68.9	1017	1670	5.603039	
10	2	17	96	1767		6.124612	
11	2	17	52.7	1838		7.143835	
12	1	17	69.8			7.758628	
13	2	17	79.1	1953		8.373292	
14	1	17	98.5			8.429816	
15	2	17	97.2	1887		9.533482	
16	1	17	67.9			10.057325	
17	2	17	52.9	1462		10.602347	
18	1	17	83.8			11.210313	
19	2	17	99.2	1202		11.485783	

Bin5 Statistics 26

Trial #	Pulse	Chirp (MHz)	Pulse Width (µS)	Pulse 1-2 spacing (µS)	Pulse 2-3 spacing (µS)	Pulse Start(S)	Detection (1:yes; 0:no)
0	3	16	97.7	1243	1415	0.25324	1
1	3	16	56.3	1187	1470	1.410317	
2	2	16	56.3	1167		1.611875	
3	2	16	88.6	1924		2.744226	
4	1	16	55.7			3.923528	
5	3	16	82.2	1635	1150	4.30869	
6	3	16	58.9	1916	1287	4.980324	
7	3	16	96.3	1317	1084	5.704924	
8	1	16	67.5			6.890469	
9	2	16	77.6	1858		7.710142	
10	2	16	94.7	1203		8.413809	
11	3	16	78.4	1740	1814	9.155191	
12	1	16	69.8			10.388403	
13	1	16	78.2			10.827183	
14	1	16	90			11.331693	

Bin5 Statistics 27

Trial #	Pulse	Chirp (MHz)	Pulse Width (µS)	Pulse 1-2 spacing (µS)	Pulse 2-3 spacing (µS)	Pulse Start(S)	Detection (1:yes; 0:no)
0	3	20	90.7	1107	1792	0.249481	1
1	3	20	86.1	1493	1222	1.303457	
2	1	20	93.6			1.766836	
3	2	20	81.8	1179		2.175092	
4	1	20	73.3			3.193805	
5	2	20	76.3	1850		3.910266	
6	2	20	65.3	1659		4.389516	
7	2	20	62.3	1554		4.838489	
8	1	20	96.3			5.697184	
9	2	20	58.6	1677		6.499607	
10	2	20	92.4	1497		6.753851	
11	2	20	60.3	1044		7.626832	
12	2	20	55	1909		8.625026	
13	2	20	99	1660		8.838836	
14	2	20	81.8	1909		9.656367	
15	3	20	83.8	1775	1022	10.274061	
16	3	20	66.2	1254	1837	10.844128	
17	3	20	86.6	1529	1242	11.902452	

Bin5 Statistics 28

Trial #	Pulse	Chirp (MHz)	Pulse Width (µS)	Pulse 1-2 spacing (uS)	Pulse 2-3 spacing (uS)	Pulse Start(S)	Detection (1:yes; 0:no)
0	2	19	54.6	1087		0.647258	1
1	1	19	79.2			1.093491	
2	1	19	83.6			1.792644	
3	2	19	95.4	1246		2.818173	
4	3	19	81.7	1082	1431	3.936095	
5	2	19	71.7	1120		4.523489	
6	2	19	69.8	1934		5.628791	
7	2	19	96.2	1324		6.784948	
8	2	19	64.6	1726		7.68239	
9	2	19	96.7	1717		8.110611	
10	1	19	71.3			8.832467	
11	2	19	61	1366		9.662805	
12	2	19	53.5	1214		10.7087	
13	3	19	87.9	1139	1975	11.377983	

Bin5 Statistics 29

Trial #	Pulse	Chirp (MHz)	Pulse Width (µS)	Pulse 1-2 spacing (uS)	Pulse 2-3 spacing (uS)	Pulse Start(S)	Detection (1:yes; 0:no)
0	2	12	76.1	1833		0.567584	1
1	2	12	71.7	1033		1.00348	
2	3	12	77.9	1815	1250	2.736157	
3	1	12	99.5			2.962097	
4	3	12	87.6	1421	1747	4.198758	
5	3	12	73.1	1125	1412	4.626761	
6	2	12	95	1424		5.870881	
7	1	12	87.7			7.006996	
8	3	12	79.9	1005	1085	7.949031	
9	2	12	97.2	1229		8.481643	
10	1	12	53.4			9.897165	
11	2	12	52.3	1453		10.944866	
12	1	12	77.9			11.277805	

Bin5 Statistics 30

Trial #	Pulse	Chirp (MHz)	Pulse Width (µS)	Pulse 1-2 spacing (µS)	Pulse 2-3 spacing (µS)	Pulse Start(S)	Detection (1:yes; 0:no)
0	2	16	89.3	1280		0.348373	1
1	1	16	68.8			1.952132	
2	2	16	83.7	1329		2.429008	
3	2	16	75.7	1099		3.412344	
4	1	16	68.8			4.973589	
5	3	16	99.3	1190	1079	5.351257	
6	2	16	90.2	1176		6.34113	
7	2	16	69.1	1050		7.74747	
8	1	16	77.4			8.261613	
9	2	16	62.2	1848		9.145737	
10	1	16	86.1			10.316586	
11	2	16	94.7	1121		11.814482	

Table-6 Radar Type 6 Statistical Performance

Trial #	Fc (MHz)	Pulse /Burst	Pulse Width (µS)	PRI (µs)	Detection (1:yes; 0:no)	Hopping Sequence
1	5270	9	1	333	1	5666.0, 5470.0, 5422.0, 5509.0, 5309.0, 5264.0, 5519.0, 5262.0, 5359.0, 5252.0, 5609.0, 5360.0, 5415.0, 5703.0, 5537.0, 5418.0, 5524.0, 5503.0, 5400.0, 5485.0, 5310.0, 5492.0, 5466.0, 5354.0, 5283.0, 5500.0, 5496.0, 5346.0, 5711.0, 5622.0, 5565.0, 5323.0, 5355.0, 5303.0, 5630.0, 5342.0, 5285.0, 5478.0, 5263.0, 5431.0, 5258.0, 5675.0, 5632.0, 5504.0, 5396.0, 5456.0, 5316.0, 5620.0, 5533.0, 5278.0, 5370.0, 5461.0, 5598.0, 5595.0, 5408.0, 5719.0, 5364.0, 5557.0, 5571.0, 5676.0, 5441.0, 5624.0, 5627.0, 5260.0, 5407.0, 5351.0, 5379.0, 5556.0, 5319.0, 5382.0, 5486.0, 5405.0, 5287.0, 5314.0, 5444.0, 5411.0, 5474.0, 5383.0, 5633.0, 5552.0, 5430.0, 5642.0, 5682.0, 5508.0, 5445.0, 5469.0, 5626.0, 5409.0, 5715.0, 5290.0, 5381.0, 5699.0, 5380.0, 5694.0, 5495.0, 5637.0, 5452.0, 5352.0, 5649.0, 5306.0 (number of hits: 5)
2	5270	9	1	333	0	0
3	5270	9	1	333	1	5287.0, 5669.0, 5512.0, 5639.0, 5447.0, 5451.0, 5518.0, 5708.0, 5415.0, 5429.0, 5622.0, 5306.0, 5458.0, 5706.0, 5348.0, 5409.0, 5584.0, 5427.0, 5644.0, 5564.0, 5693.0, 5689.0, 5360.0, 5253.0, 5587.0, 5715.0, 5483.0, 5641.0, 5318.0, 5467.0, 5481.0, 5619.0, 5355.0, 5713.0, 5394.0, 5698.0, 5678.0, 5262.0, 5660.0, 5387.0, 5704.0, 5616.0, 5531.0, 5697.0, 5572.0, 5430.0, 5325.0, 5335.0, 5300.0, 5523.0, 5602.0, 5666.0, 5617.0, 5403.0, 5648.0, 5516.0, 5286.0, 5442.0, 5557.0, 5330.0, 5448.0, 5362.0, 5594.0, 5333.0, 5367.0, 5263.0, 5599.0, 5528.0, 5595.0, 5521.0, 5614.0, 5571.0, 5548.0, 5356.0, 5284.0, 5336.0, 5370.0, 5480.0, 5524.0, 5724.0, 5373.0, 5418.0, 5640.0, 5582.0, 5270.0, 5600.0, 5592.0, 5260.0, 5559.0, 5513.0, 5504.0, 5650.0, 5551.0, 5305.0, 5303.0, 5542.0, 5658.0, 5416.0, 5590.0, 5565.0 (number of hits: 4)
4	5270	9	1	333	1	5251.0, 5605.0, 5359.0, 5355.0, 5488.0, 5464.0, 5299.0, 5678.0, 5328.0, 5713.0, 5591.0, 5623.0, 5342.0, 5298.0, 5257.0, 5548.0, 5379.0, 5358.0, 5570.0, 5459.0, 5324.0, 5519.0, 5253.0, 5337.0, 5534.0, 5566.0, 5439.0, 5397.0, 5568.0, 5712.0, 5641.0, 5506.0, 5586.0, 5281.0, 5318.0, 5429.0, 5356.0, 5595.0, 5551.0, 5652.0, 5481.0, 5461.0, 5535.0, 5331.0, 5420.0, 5458.0, 5637.0, 5571.0, 5367.0, 5505.0, 5300.0, 5333.0, 5280.0, 5648.0, 5339.0, 5384.0, 5584.0, 5466.0, 5270.0, 5684.0, 5357.0, 5377.0, 5423.0, 5386.0, 5292.0,

						5670.0, 5612.0, 5259.0, 5643.0, 5302.0, 5672.0, 5413.0, 5543.0, 5325.0, 5363.0, 5462.0, 5514.0, 5409.0, 5695.0, 5282.0, 5317.0, 5453.0, 5563.0, 5610.0, 5618.0, 5516.0, 5677.0, 5452.0, 5541.0, 5700.0, 5693.0, 5659.0, 5279.0, 5661.0, 5558.0, 5370.0, 5445.0, 5536.0, 5579.0, 5630.0 (number of hits: 2)
5	5270	9	1	333	1	5411.0, 5628.0, 5456.0, 5381.0, 5295.0, 5663.0, 5391.0, 5298.0, 5529.0, 5608.0, 5482.0, 5343.0, 5477.0, 5380.0, 5564.0, 5346.0, 5331.0, 5550.0, 5592.0, 5557.0, 5336.0, 5367.0, 5501.0, 5252.0, 5469.0, 5302.0, 5447.0, 5623.0, 5277.0, 5600.0, 5681.0, 5573.0, 5495.0, 5561.0, 5547.0, 5263.0, 5342.0, 5709.0, 5341.0, 5353.0, 5719.0, 5625.0, 5308.0, 5385.0, 5525.0, 5540.0, 5684.0, 5421.0, 5289.0, 5637.0, 5649.0, 5539.0, 5630.0, 5386.0, 5290.0, 5588.0, 5387.0, 5388.0, 5634.0, 5475.0, 5711.0, 5605.0, 5690.0, 5549.0, 5518.0, 5441.0, 5339.0, 5497.0, 5399.0, 5660.0, 5698.0, 5615.0, 5347.0, 5656.0, 5337.0, 5472.0, 5597.0, 5376.0, 5271.0, 5432.0, 5568.0, 5265.0, 5430.0, 5465.0, 5258.0, 5654.0, 5624.0, 5619.0, 5514.0, 5640.0, 5556.0, 5492.0, 5506.0, 5419.0, 5431.0, 5541.0, 5673.0, 5516.0, 5454.0, 5251.0 (number of hits: 4)
6	5270	9	1	333	1	5301.0, 5689.0, 5488.0, 5603.0, 5439.0, 5574.0, 5668.0, 5687.0, 5266.0, 5264.0, 5711.0, 5555.0, 5444.0, 5694.0, 5512.0, 5533.0, 5570.0, 5334.0, 5422.0, 5261.0, 5647.0, 5586.0, 5559.0, 5348.0, 5613.0, 5719.0, 5532.0, 5550.0, 5589.0, 5281.0, 5514.0, 5426.0, 5710.0, 5643.0, 5496.0, 5675.0, 5343.0, 5680.0, 5253.0, 5453.0, 5638.0, 5457.0, 5342.0, 5397.0, 5275.0, 5378.0, 5541.0, 5419.0, 5462.0, 5526.0, 5333.0, 5344.0, 5498.0, 5718.0, 5425.0, 5429.0, 5418.0, 5393.0, 5272.0, 5584.0, 5298.0, 5361.0, 5564.0, 5502.0, 5635.0, 5618.0, 5340.0, 5404.0, 5521.0, 5376.0, 5484.0, 5410.0, 5308.0, 5285.0, 5621.0, 5604.0, 5471.0, 5708.0, 5396.0, 5676.0, 5656.0, 5530.0, 5568.0, 5628.0, 5518.0, 5706.0, 5609.0, 5311.0, 5297.0, 5466.0, 5282.0, 5724.0, 5276.0, 5337.0, 5651.0, 5477.0, 5310.0, 5686.0, 5399.0, 5271.0 (number of hits: 7)
7	5270	9	1	333	1	5369.0, 5517.0, 5471.0, 5364.0, 5283.0, 5400.0, 5668.0, 5624.0, 5385.0, 5365.0, 5572.0, 5619.0, 5345.0, 5372.0, 5593.0, 5284.0, 5640.0, 5384.0, 5397.0, 5381.0, 5599.0, 5431.0, 5509.0, 5579.0, 5464.0, 5377.0, 5447.0, 5715.0, 5500.0, 5616.0, 5537.0, 5642.0, 5412.0, 5631.0, 5558.0, 5660.0, 5379.0, 5708.0, 5644.0, 5649.0, 5602.0, 5277.0, 5436.0, 5429.0, 5360.0, 5674.0, 5532.0, 5506.0, 5515.0, 5432.0, 5414.0, 5294.0, 5585.0, 5281.0, 5353.0,

						5334.0, 5454.0, 5693.0, 5661.0, 5481.0, 5268.0, 5528.0, 5463.0, 5694.0, 5698.0, 5672.0, 5503.0, 5298.0, 5373.0, 5324.0, 5346.0, 5382.0, 5406.0, 5566.0, 5598.0, 5622.0, 5498.0, 5371.0, 5604.0, 5267.0, 5458.0, 5690.0, 5529.0, 5327.0, 5435.0, 5321.0, 5652.0, 5623.0, 5314.0, 5635.0, 5292.0, 5383.0, 5265.0, 5273.0, 5710.0, 5405.0, 5450.0, 5545.0, 5714.0, 5387.0 (number of hits: 5)
8	5270	9	1	333	1	5638.0, 5365.0, 5286.0, 5606.0, 5364.0, 5320.0, 5586.0, 5423.0, 5408.0, 5278.0, 5387.0, 5722.0, 5520.0, 5287.0, 5589.0, 5443.0, 5273.0, 5549.0, 5502.0, 5318.0, 5342.0, 5291.0, 5428.0, 5346.0, 5426.0, 5542.0, 5570.0, 5637.0, 5600.0, 5602.0, 5623.0, 5324.0, 5557.0, 5655.0, 5708.0, 5327.0, 5306.0, 5276.0, 5256.0, 5564.0, 5339.0, 5530.0, 5707.0, 5263.0, 5609.0, 5627.0, 5485.0, 5517.0, 5482.0, 5679.0, 5645.0, 5349.0, 5677.0, 5344.0, 5412.0, 5394.0, 5568.0, 5296.0, 5573.0, 5311.0, 5595.0, 5533.0, 5663.0, 5519.0, 5255.0, 5337.0, 5632.0, 5317.0, 5499.0, 5257.0, 5427.0, 5636.0, 5461.0, 5381.0, 5468.0, 5336.0, 5439.0, 5355.0, 5674.0, 5705.0, 5684.0, 5646.0, 5697.0, 5274.0, 5266.0, 5469.0, 5492.0, 5553.0, 5644.0, 5338.0, 5706.0, 5396.0, 5635.0, 5401.0, 5389.0, 5253.0, 5603.0, 5524.0, 5611.0, 5458.0 (number of hits: 6)
9	5270	9	1	333	1	5708.0, 5264.0, 5499.0, 5610.0, 5332.0, 5516.0, 5647.0, 5491.0, 5596.0, 5595.0, 5458.0, 5721.0, 5678.0, 5570.0, 5325.0, 5377.0, 5664.0, 5315.0, 5707.0, 5701.0, 5558.0, 5672.0, 5473.0, 5663.0, 5295.0, 5642.0, 5346.0, 5486.0, 5498.0, 5631.0, 5439.0, 5700.0, 5553.0, 5280.0, 5537.0, 5416.0, 5318.0, 5680.0, 5523.0, 5400.0, 5463.0, 5562.0, 5555.0, 5674.0, 5358.0, 5294.0, 5317.0, 5327.0, 5696.0, 5671.0, 5669.0, 5650.0, 5526.0, 5470.0, 5259.0, 5693.0, 5468.0, 5535.0, 5522.0, 5684.0, 5380.0, 5258.0, 5489.0, 5363.0, 5419.0, 5705.0, 5654.0, 5580.0, 5607.0, 5572.0, 5511.0, 5602.0, 5456.0, 5372.0, 5640.0, 5600.0, 5686.0, 5593.0, 5591.0, 5326.0, 5716.0, 5374.0, 5589.0, 5510.0, 5432.0, 5697.0, 5635.0, 5561.0, 5393.0, 5661.0, 5388.0, 5347.0, 5490.0, 5567.0, 5289.0, 5639.0, 5585.0, 5436.0, 5447.0, 5273.0 (number of hits: 2)
10	5270	9	1	333	1	5641.0, 5545.0, 5411.0, 5688.0, 5589.0, 5640.0, 5388.0, 5600.0, 5278.0, 5667.0, 5626.0, 5476.0, 5437.0, 5254.0, 5639.0, 5523.0, 5468.0, 5285.0, 5327.0, 5365.0, 5530.0, 5336.0, 5269.0, 5670.0, 5671.0, 5544.0, 5638.0, 5511.0, 5338.0, 5342.0, 5713.0, 5664.0, 5653.0, 5301.0, 5615.0, 5347.0, 5541.0, 5261.0, 5363.0, 5577.0, 5418.0, 5271.0, 5457.0, 5435.0, 5348.0

						5287.0, 5644.0, 5629.0, 5308.0, 5317.0, 5417.0, 5450.0, 5355.0, 5699.0, 5377.0, 5252.0, 5391.0, 5447.0, 5512.0, 5633.0, 5535.0, 5322.0, 5619.0, 5406.0, 5469.0, 5515.0, 5529.0, 5623.0, 5543.0, 5646.0, 5715.0, 5719.0, 5693.0, 5697.0, 5359.0, 5473.0, 5380.0, 5280.0, 5309.0, 5303.0, 5381.0, 5591.0, 5493.0, 5262.0, 5632.0, 5655.0, 5403.0, 5394.0, 5679.0, 5620.0, 5396.0, 5488.0, 5284.0, 5306.0, 5560.0, 5442.0, 5386.0, 5692.0, 5371.0, 5695.0 (number of hits: 5)
11	5280	9	1	333	1	5509.0, 5593.0, 5570.0, 5271.0, 5615.0, 5328.0, 5258.0, 5657.0, 5381.0, 5647.0, 5540.0, 5560.0, 5525.0, 5354.0, 5518.0, 5386.0, 5707.0, 5441.0, 5721.0, 5516.0, 5532.0, 5553.0, 5621.0, 5369.0, 5277.0, 5517.0, 5689.0, 5413.0, 5499.0, 5718.0, 5631.0, 5260.0, 5427.0, 5255.0, 5335.0, 5409.0, 5342.0, 5270.0, 5266.0, 5580.0, 5263.0, 5397.0, 5503.0, 5300.0, 5273.0, 5708.0, 5356.0, 5534.0, 5680.0, 5470.0, 5596.0, 5324.0, 5308.0, 5603.0, 5402.0, 5290.0, 5444.0, 5538.0, 5378.0, 5513.0, 5419.0, 5469.0, 5480.0, 5660.0, 5350.0, 5598.0, 5619.0, 5537.0, 5366.0, 5399.0, 5303.0, 5360.0, 5482.0, 5608.0, 5388.0, 5412.0, 5276.0, 5620.0, 5334.0, 5357.0, 5637.0, 5337.0, 5423.0, 5556.0, 5506.0, 5452.0, 5346.0, 5609.0, 5655.0, 5668.0, 5644.0, 5521.0, 5341.0, 5355.0, 5477.0, 5251.0, 5611.0, 5368.0, 5504.0, 5543.0 (number of hits: 5)
12	5280	9	1	333	1	5519.0, 5559.0, 5524.0, 5298.0, 5651.0, 5596.0, 5642.0, 5277.0, 5399.0, 5385.0, 5690.0, 5383.0, 5708.0, 5582.0, 5506.0, 5478.0, 5630.0, 5683.0, 5430.0, 5655.0, 5590.0, 5333.0, 5652.0, 5376.0, 5586.0, 5299.0, 5255.0, 5633.0, 5530.0, 5606.0, 5449.0, 5351.0, 5309.0, 5647.0, 5318.0, 5551.0, 5532.0, 5479.0, 5464.0, 5640.0, 5307.0, 5272.0, 5627.0, 5265.0, 5579.0, 5256.0, 5313.0, 5645.0, 5428.0, 5542.0, 5712.0, 5635.0, 5560.0, 5615.0, 5686.0, 5349.0, 5482.0, 5460.0, 5662.0, 5331.0, 5562.0, 5523.0, 5624.0, 5696.0, 5360.0, 5695.0, 5553.0, 5618.0, 5456.0, 5346.0, 5296.0, 5257.0, 5567.0, 5448.0, 5598.0, 5589.0, 5566.0, 5282.0, 5347.0, 5337.0, 5379.0, 5581.0, 5301.0, 5688.0, 5620.0, 5493.0, 5491.0, 5634.0, 5537.0, 5623.0, 5511.0, 5280.0, 5715.0, 5561.0, 5545.0, 5539.0, 5454.0, 5476.0, 5320.0, 5427.0 (number of hits: 4)
13	5280	9	1	333	1	5526.0, 5718.0, 5600.0, 5333.0, 5588.0, 5549.0, 5513.0, 5677.0, 5339.0, 5619.0, 5420.0, 5402.0, 5523.0, 5484.0, 5605.0, 5413.0, 5723.0, 5562.0, 5264.0, 5581.0, 5556.0, 5696.0, 5698.0, 5546.0, 5464.0, 5424.0, 5622.0, 5394.0, 5711.0, 5428.0, 5476.0, 5326.0, 5701.0, 5652.0, 5485.0

						5405.0, 5482.0, 5567.0, 5710.0, 5383.0, 5719.0, 5426.0, 5467.0, 5525.0, 5545.0, 5675.0, 5345.0, 5456.0, 5515.0, 5281.0, 5649.0, 5520.0, 5679.0, 5672.0, 5630.0, 5432.0, 5595.0, 5521.0, 5397.0, 5571.0, 5627.0, 5273.0, 5322.0, 5466.0, 5330.0, 5637.0, 5470.0, 5558.0, 5498.0, 5294.0, 5348.0, 5460.0, 5621.0, 5321.0, 5449.0, 5663.0, 5332.0, 5477.0, 5423.0, 5716.0, 5536.0, 5659.0, 5481.0, 5415.0, 5441.0, 5318.0, 5618.0, 5299.0, 5421.0, 5419.0, 5642.0, 5486.0, 5706.0, 5269.0, 5452.0, 5559.0, 5714.0, 5493.0, 5358.0, 5285.0 (number of hits: 3)
14	5280	9	1	333	1	5723.0, 5455.0, 5504.0, 5318.0, 5539.0, 5312.0, 5257.0, 5360.0, 5687.0, 5414.0, 5614.0, 5695.0, 5292.0, 5704.0, 5269.0, 5675.0, 5398.0, 5587.0, 5275.0, 5534.0, 5288.0, 5340.0, 5441.0, 5378.0, 5404.0, 5272.0, 5430.0, 5250.0, 5397.0, 5713.0, 5601.0, 5410.0, 5586.0, 5357.0, 5266.0, 5656.0, 5638.0, 5324.0, 5673.0, 5279.0, 5300.0, 5314.0, 5370.0, 5477.0, 5253.0, 5445.0, 5328.0, 5577.0, 5629.0, 5607.0, 5682.0, 5457.0, 5528.0, 5282.0, 5418.0, 5345.0, 5442.0, 5612.0, 5402.0, 5573.0, 5699.0, 5423.0, 5373.0, 5449.0, 5276.0, 5256.0, 5532.0, 5287.0, 5271.0, 5660.0, 5493.0, 5618.0, 5566.0, 5631.0, 5382.0, 5316.0, 5609.0, 5290.0, 5416.0, 5599.0, 5291.0, 5470.0, 5463.0, 5437.0, 5305.0, 5692.0, 5377.0, 5298.0, 5688.0, 5583.0, 5343.0, 5451.0, 5667.0, 5722.0, 5472.0, 5284.0, 5335.0, 5412.0, 5299.0, 5396.0 (number of hits: 9)
15	5280	9	1	333	1	5294.0, 5697.0, 5664.0, 5538.0, 5330.0, 5283.0, 5379.0, 5576.0, 5575.0, 5307.0, 5377.0, 5532.0, 5506.0, 5583.0, 5688.0, 5641.0, 5273.0, 5623.0, 5625.0, 5400.0, 5663.0, 5401.0, 5280.0, 5309.0, 5610.0, 5695.0, 5621.0, 5633.0, 5673.0, 5720.0, 5686.0, 5375.0, 5277.0, 5515.0, 5361.0, 5622.0, 5387.0, 5389.0, 5324.0, 5665.0, 5565.0, 5518.0, 5472.0, 5320.0, 5524.0, 5264.0, 5605.0, 5323.0, 5467.0, 5718.0, 5549.0, 5287.0, 5643.0, 5716.0, 5638.0, 5490.0, 5500.0, 5627.0, 5577.0, 5574.0, 5327.0, 5614.0, 5310.0, 5457.0, 5470.0, 5426.0, 5562.0, 5619.0, 5578.0, 5271.0, 5251.0, 5715.0, 5474.0, 5653.0, 5634.0, 5296.0, 5333.0, 5585.0, 5675.0, 5399.0, 5364.0, 5406.0, 5620.0, 5590.0, 5274.0, 5357.0, 5510.0, 5704.0, 5706.0, 5291.0, 5409.0, 5618.0, 5316.0, 5373.0, 5300.0, 5690.0, 5395.0, 5598.0, 5555.0, 5712.0 (number of hits: 7)
16	5280	9	1	333	0	0
17	5280	9	1	333	1	5469.0, 5367.0, 5455.0, 5557.0, 5313.0, 5646.0, 5587.0, 5685.0, 5717.0, 5262.0, 5307.0, 5381.0, 5330.0, 5621.0, 5397.0, 5500.0, 5252.0, 5414.0, 5346.0, 5320.0,

						5629.0, 5420.0, 5487.0, 5386.0, 5308.0, 5548.0, 5325.0, 5665.0, 5555.0, 5553.0, 5508.0, 5705.0, 5589.0, 5582.0, 5284.0, 5591.0, 5480.0, 5373.0, 5584.0, 5490.0, 5638.0, 5543.0, 5461.0, 5299.0, 5512.0, 5496.0, 5280.0, 5354.0, 5278.0, 5637.0, 5394.0, 5305.0, 5344.0, 5303.0, 5453.0, 5451.0, 5485.0, 5288.0, 5443.0, 5402.0, 5372.0, 5619.0, 5301.0, 5257.0, 5588.0, 5690.0, 5468.0, 5383.0, 5688.0, 5276.0, 5333.0, 5396.0, 5651.0, 5706.0, 5403.0, 5600.0, 5520.0, 5569.0, 5631.0, 5648.0, 5382.0, 5570.0, 5523.0, 5294.0, 5454.0, 5532.0, 5462.0, 5337.0, 5312.0, 5360.0, 5713.0, 5615.0, 5272.0, 5481.0, 5563.0, 5422.0, 5689.0, 5425.0, 5366.0, 5466.0 (number of hits: 6)
18	5280	9	1	333	1	5704.0, 5302.0, 5307.0, 5268.0, 5556.0, 5511.0, 5702.0, 5638.0, 5536.0, 5385.0, 5549.0, 5396.0, 5419.0, 5251.0, 5590.0, 5608.0, 5513.0, 5438.0, 5468.0, 5332.0, 5517.0, 5478.0, 5641.0, 5558.0, 5448.0, 5387.0, 5633.0, 5697.0, 5689.0, 5658.0, 5580.0, 5460.0, 5642.0, 5667.0, 5565.0, 5612.0, 5644.0, 5711.0, 5397.0, 5292.0, 5272.0, 5304.0, 5579.0, 5668.0, 5601.0, 5596.0, 5592.0, 5690.0, 5458.0, 5614.0, 5322.0, 5606.0, 5279.0, 5333.0, 5323.0, 5355.0, 5680.0, 5340.0, 5329.0, 5281.0, 5424.0, 5712.0, 5595.0, 5408.0, 5635.0, 5477.0, 5432.0, 5499.0, 5476.0, 5585.0, 5309.0, 5466.0, 5391.0, 5310.0, 5377.0, 5522.0, 5376.0, 5414.0, 5305.0, 5349.0, 5485.0, 5277.0, 5264.0, 5335.0, 5532.0, 5260.0, 5357.0, 5406.0, 5328.0, 5543.0, 5306.0, 5297.0, 5719.0, 5373.0, 5274.0, 5428.0, 5261.0, 5617.0, 5463.0, 5325.0 (number of hits: 5)
19	5280	9	1	333	1	5289.0, 5565.0, 5340.0, 5552.0, 5707.0, 5346.0, 5582.0, 5407.0, 5688.0, 5300.0, 5610.0, 5493.0, 5306.0, 5450.0, 5706.0, 5708.0, 5536.0, 5597.0, 5322.0, 5497.0, 5290.0, 5526.0, 5555.0, 5576.0, 5635.0, 5315.0, 5650.0, 5626.0, 5495.0, 5531.0, 5679.0, 5545.0, 5321.0, 5530.0, 5455.0, 5634.0, 5514.0, 5298.0, 5594.0, 5605.0, 5489.0, 5351.0, 5405.0, 5304.0, 5413.0, 5257.0, 5673.0, 5292.0, 5515.0, 5644.0, 5683.0, 5642.0, 5499.0, 5318.0, 5553.0, 5701.0, 5672.0, 5558.0, 5280.0, 5443.0, 5333.0, 5641.0, 5551.0, 5541.0, 5587.0, 5433.0, 5586.0, 5288.0, 5722.0, 5445.0, 5592.0, 5374.0, 5625.0, 5694.0, 5467.0, 5676.0, 5664.0, 5412.0, 5251.0, 5599.0, 5720.0, 5403.0, 5279.0, 5636.0, 5564.0, 5465.0, 5652.0, 5286.0, 5645.0, 5615.0, 5629.0, 5456.0, 5547.0, 5607.0, 5368.0, 5331.0, 5663.0, 5406.0, 5404.0, 5395.0 (number of hits: 5)
20	5280	9	1	333	1	5331.0, 5323.0, 5654.0, 5707.0, 5461.0, 5601.0, 5321.0, 5292.0, 5668.0, 5498.0

						5720.0, 5666.0, 5286.0, 5284.0, 5562.0, 5300.0, 5629.0, 5656.0, 5567.0, 5325.0, 5346.0, 5285.0, 5472.0, 5582.0, 5678.0, 5610.0, 5499.0, 5685.0, 5314.0, 5437.0, 5524.0, 5262.0, 5403.0, 5419.0, 5709.0, 5456.0, 5677.0, 5490.0, 5615.0, 5455.0, 5660.0, 5519.0, 5486.0, 5451.0, 5663.0, 5602.0, 5305.0, 5378.0, 5384.0, 5250.0, 5705.0, 5597.0, 5651.0, 5612.0, 5550.0, 5409.0, 5537.0, 5459.0, 5715.0, 5402.0, 5648.0, 5568.0, 5671.0, 5688.0, 5298.0, 5334.0, 5662.0, 5328.0, 5515.0, 5639.0, 5698.0, 5590.0, 5337.0, 5557.0, 5449.0, 5452.0, 5473.0, 5509.0, 5436.0, 5496.0, 5631.0, 5683.0, 5703.0, 5338.0, 5632.0, 5324.0, 5627.0, 5609.0, 5642.0, 5309.0, 5330.0, 5356.0, 5434.0, 5383.0, 5684.0, 5565.0, 5381.0, 5370.0, 5428.0, 5351.0 (number of hits: 3)
21	5290	9	1	333	1	5495.0, 5625.0, 5412.0, 5292.0, 5592.0, 5558.0, 5669.0, 5373.0, 5599.0, 5269.0, 5651.0, 5489.0, 5652.0, 5338.0, 5699.0, 5297.0, 5564.0, 5514.0, 5485.0, 5454.0, 5640.0, 5335.0, 5577.0, 5452.0, 5478.0, 5407.0, 5404.0, 5481.0, 5266.0, 5716.0, 5273.0, 5325.0, 5562.0, 5354.0, 5386.0, 5706.0, 5468.0, 5627.0, 5528.0, 5634.0, 5398.0, 5498.0, 5289.0, 5445.0, 5456.0, 5694.0, 5569.0, 5527.0, 5420.0, 5334.0, 5548.0, 5646.0, 5695.0, 5647.0, 5611.0, 5600.0, 5602.0, 5447.0, 5377.0, 5263.0, 5605.0, 5283.0, 5682.0, 5305.0, 5512.0, 5308.0, 5475.0, 5433.0, 5304.0, 5581.0, 5721.0, 5643.0, 5486.0, 5572.0, 5339.0, 5428.0, 5307.0, 5623.0, 5351.0, 5637.0, 5516.0, 5596.0, 5465.0, 5265.0, 5567.0, 5610.0, 5389.0, 5507.0, 5681.0, 5612.0, 5616.0, 5295.0, 5617.0, 5343.0, 5636.0, 5460.0, 5619.0, 5476.0, 5678.0, 5288.0 (number of hits: 6)
22	5290	9	1	333	1	5414.0, 5485.0, 5328.0, 5260.0, 5503.0, 5375.0, 5668.0, 5481.0, 5263.0, 5662.0, 5717.0, 5315.0, 5270.0, 5698.0, 5432.0, 5577.0, 5697.0, 5712.0, 5646.0, 5324.0, 5346.0, 5374.0, 5608.0, 5564.0, 5292.0, 5410.0, 5692.0, 5583.0, 5261.0, 5476.0, 5454.0, 5426.0, 5445.0, 5280.0, 5589.0, 5704.0, 5458.0, 5291.0, 5372.0, 5587.0, 5711.0, 5501.0, 5394.0, 5469.0, 5382.0, 5401.0, 5483.0, 5262.0, 5648.0, 5566.0, 5613.0, 5295.0, 5361.0, 5553.0, 5606.0, 5559.0, 5447.0, 5331.0, 5342.0, 5499.0, 5667.0, 5441.0, 5383.0, 5524.0, 5643.0, 5462.0, 5385.0, 5435.0, 5300.0, 5370.0, 5475.0, 5660.0, 5548.0, 5670.0, 5297.0, 5309.0, 5287.0, 5618.0, 5491.0, 5701.0, 5594.0, 5349.0, 5597.0, 5347.0, 5569.0, 5551.0, 5655.0, 5681.0, 5705.0, 5555.0, 5411.0, 5307.0, 5449.0, 5637.0, 5380.0, 5305.0, 5264.0, 5320.0, 5702.0, 5537.0 (number of hits: 6)

23	5290	9	1	333	1	5721.0, 5489.0, 5405.0, 5363.0, 5262.0, 5670.0, 5578.0, 5329.0, 5589.0, 5706.0, 5457.0, 5672.0, 5382.0, 5634.0, 5586.0, 5479.0, 5570.0, 5647.0, 5698.0, 5325.0, 5599.0, 5255.0, 5583.0, 5705.0, 5467.0, 5252.0, 5509.0, 5407.0, 5314.0, 5369.0, 5269.0, 5540.0, 5401.0, 5697.0, 5519.0, 5331.0, 5618.0, 5282.0, 5353.0, 5535.0, 5518.0, 5633.0, 5250.0, 5668.0, 5343.0, 5323.0, 5607.0, 5267.0, 5526.0, 5277.0, 5674.0, 5312.0, 5420.0, 5655.0, 5272.0, 5520.0, 5419.0, 5691.0, 5422.0, 5309.0, 5271.0, 5688.0, 5582.0, 5587.0, 5598.0, 5532.0, 5391.0, 5521.0, 5660.0, 5324.0, 5702.0, 5426.0, 5717.0, 5624.0, 5511.0, 5320.0, 5288.0, 5555.0, 5601.0, 5628.0, 5400.0, 5690.0, 5710.0, 5718.0, 5377.0, 5310.0, 5402.0, 5454.0, 5335.0, 5646.0, 5666.0, 5609.0, 5439.0, 5399.0, 5592.0, 5332.0, 5529.0, 5503.0, 5408.0, 5669.0 (number of hits: 2)
24	5290	9	1	333	1	5346.0, 5496.0, 5412.0, 5603.0, 5619.0, 5549.0, 5621.0, 5498.0, 5635.0, 5273.0, 5293.0, 5705.0, 5501.0, 5670.0, 5281.0, 5308.0, 5562.0, 5424.0, 5680.0, 5278.0, 5435.0, 5651.0, 5343.0, 5638.0, 5266.0, 5381.0, 5531.0, 5301.0, 5493.0, 5299.0, 5314.0, 5578.0, 5462.0, 5433.0, 5704.0, 5265.0, 5543.0, 5681.0, 5618.0, 5508.0, 5602.0, 5408.0, 5624.0, 5520.0, 5659.0, 5256.0, 5268.0, 5669.0, 5582.0, 5478.0, 5614.0, 5652.0, 5555.0, 5321.0, 5368.0, 5682.0, 5722.0, 5395.0, 5702.0, 5530.0, 5544.0, 5328.0, 5364.0, 5673.0, 5404.0, 5668.0, 5575.0, 5541.0, 5688.0, 5567.0, 5295.0, 5302.0, 5526.0, 5441.0, 5450.0, 5379.0, 5620.0, 5641.0, 5476.0, 5377.0, 5347.0, 5437.0, 5417.0, 5539.0, 5589.0, 5716.0, 5502.0, 5580.0, 5405.0, 5667.0, 5654.0, 5715.0, 5298.0, 5251.0, 5490.0, 5535.0, 5671.0, 5653.0, 5279.0, 5701.0 (number of hits: 5)
25	5290	9	1	333	1	5690.0, 5683.0, 5283.0, 5301.0, 5291.0, 5621.0, 5513.0, 5275.0, 5606.0, 5355.0, 5481.0, 5536.0, 5512.0, 5419.0, 5630.0, 5535.0, 5663.0, 5411.0, 5478.0, 5529.0, 5483.0, 5550.0, 5416.0, 5384.0, 5695.0, 5689.0, 5491.0, 5336.0, 5327.0, 5274.0, 5455.0, 5646.0, 5534.0, 5494.0, 5323.0, 5637.0, 5622.0, 5393.0, 5375.0, 5643.0, 5312.0, 5458.0, 5576.0, 5490.0, 5430.0, 5507.0, 5386.0, 5477.0, 5555.0, 5302.0, 5638.0, 5554.0, 5307.0, 5640.0, 5395.0, 5334.0, 5449.0, 5250.0, 5706.0, 5680.0, 5659.0, 5441.0, 5700.0, 5311.0, 5440.0, 5678.0, 5448.0, 5506.0, 5313.0, 5261.0, 5282.0, 5664.0, 5654.0, 5607.0, 5288.0, 5271.0, 5644.0, 5267.0, 5408.0, 5322.0, 5296.0, 5379.0, 5337.0, 5546.0, 5565.0, 5310.0, 5272.0, 5669.0, 5526.0, 5492.0, 5470.0, 5376.0, 5292.0, 5451.0, 5542.0,

						5456.0, 5260.0, 5418.0, 5480.0, 5497.0 (number of hits: 6)
26	5290	9	1	333	1	5422.0, 5710.0, 5373.0, 5439.0, 5650.0, 5389.0, 5296.0, 5486.0, 5661.0, 5429.0, 5534.0, 5609.0, 5368.0, 5391.0, 5372.0, 5545.0, 5610.0, 5625.0, 5487.0, 5403.0, 5574.0, 5308.0, 5350.0, 5364.0, 5535.0, 5705.0, 5467.0, 5617.0, 5660.0, 5509.0, 5261.0, 5332.0, 5654.0, 5407.0, 5426.0, 5375.0, 5257.0, 5578.0, 5690.0, 5538.0, 5693.0, 5449.0, 5644.0, 5354.0, 5615.0, 5500.0, 5602.0, 5430.0, 5306.0, 5379.0, 5312.0, 5627.0, 5566.0, 5586.0, 5323.0, 5436.0, 5299.0, 5583.0, 5658.0, 5371.0, 5273.0, 5616.0, 5327.0, 5289.0, 5648.0, 5592.0, 5630.0, 5383.0, 5441.0, 5344.0, 5642.0, 5501.0, 5516.0, 5356.0, 5488.0, 5395.0, 5519.0, 5361.0, 5359.0, 5685.0, 5347.0, 5623.0, 5438.0, 5651.0, 5466.0, 5448.0, 5260.0, 5498.0, 5386.0, 5476.0, 5345.0, 5708.0, 5525.0, 5679.0, 5394.0, 5367.0, 5264.0, 5290.0, 5268.0, 5278.0 (number of hits: 4)
27	5290	9	1	333	1	5557.0, 5527.0, 5549.0, 5611.0, 5414.0, 5387.0, 5673.0, 5372.0, 5452.0, 5639.0, 5597.0, 5422.0, 5428.0, 5534.0, 5362.0, 5537.0, 5508.0, 5723.0, 5536.0, 5339.0, 5606.0, 5665.0, 5690.0, 5579.0, 5564.0, 5678.0, 5342.0, 5421.0, 5281.0, 5469.0, 5548.0, 5290.0, 5423.0, 5399.0, 5502.0, 5486.0, 5350.0, 5650.0, 5445.0, 5674.0, 5265.0, 5624.0, 5466.0, 5394.0, 5599.0, 5576.0, 5716.0, 5374.0, 5336.0, 5395.0, 5404.0, 5686.0, 5696.0, 5543.0, 5277.0, 5618.0, 5680.0, 5711.0, 5620.0, 5360.0, 5525.0, 5416.0, 5431.0, 5590.0, 5467.0, 5313.0, 5607.0, 5600.0, 5357.0, 5694.0, 5681.0, 5506.0, 5500.0, 5656.0, 5634.0, 5286.0, 5283.0, 5460.0, 5274.0, 5482.0, 5268.0, 5715.0, 5684.0, 5415.0, 5676.0, 5386.0, 5320.0, 5698.0, 5254.0, 5490.0, 5255.0, 5288.0, 5381.0, 5312.0, 5480.0, 5471.0, 5333.0, 5484.0, 5481.0, 5341.0 (number of hits: 5)
28	5290	9	1	333	0	0
29	5290	9	1	333	1	5395.0, 5465.0, 5346.0, 5282.0, 5687.0, 5511.0, 5495.0, 5717.0, 5676.0, 5273.0, 5654.0, 5453.0, 5646.0, 5692.0, 5720.0, 5614.0, 5500.0, 5307.0, 5651.0, 5377.0, 5470.0, 5557.0, 5629.0, 5681.0, 5456.0, 5620.0, 5281.0, 5412.0, 5344.0, 5263.0, 5621.0, 5625.0, 5426.0, 5363.0, 5303.0, 5702.0, 5337.0, 5416.0, 5559.0, 5569.0, 5427.0, 5644.0, 5686.0, 5401.0, 5564.0, 5512.0, 5434.0, 5343.0, 5369.0, 5623.0, 5581.0, 5266.0, 5682.0, 5364.0, 5505.0, 5295.0, 5688.0, 5604.0, 5520.0, 5518.0, 5462.0, 5291.0, 5723.0, 5671.0, 5673.0, 5376.0, 5531.0, 5635.0, 5529.0, 5271.0, 5336.0, 5693.0, 5339.0, 5370.0, 5406.0, 5534.0, 5322.0, 5477.0, 5609.0, 5439.0,

						5353.0, 5331.0, 5299.0, 5443.0, 5510.0, 5368.0, 5262.0, 5710.0, 5479.0, 5668.0, 5442.0, 5709.0, 5574.0, 5325.0, 5454.0, 5656.0, 5606.0, 5558.0, 5330.0, 5398.0 (number of hits: 5)
30	5290	9	1	333	0	0

A.2 40 MHz Bandwidth @ 5270 MHz

Table-1A/1B Radar Type 1A/1B Statistical Performance

Trial #	Fc (MHz)	Pulse/Burst	Pulse Width (μS)	PRI (μs)	Detection (1:yes; 0:no)
1	5251	83	1	638	1
2	5251	70	1	758	1
3	5251	89	1	598	1
4	5251	62	1	858	1
5	5251	78	1	678	1
6	5270	68	1	778	1
7	5270	61	1	878	1
8	5270	95	1	558	1
9	5270	57	1	938	1
10	5270	18	1	3066	1
11	5289	59	1	898	1
12	5289	74	1	718	0
13	5289	99	1	538	1
14	5289	67	1	798	1
15	5289	92	1	578	1
16	5251	45	1	1191	1
17	5251	68	1	783	1
18	5251	55	1	962	1
19	5251	44	1	1202	1
20	5251	18	1	2953	1
21	5270	33	1	1649	1
22	5270	36	1	1505	1
23	5270	20	1	2690	1
24	5270	19	1	2890	0
25	5270	77	1	690	1
26	5289	18	1	3060	0
27	5289	21	1	2521	1
28	5289	18	1	3049	1
29	5289	28	1	1885	1
30	5289	29	1	1866	1
Detection Percentage: 90 % (>60%)					

Table-2 Radar Type 2 Statistical Performance

Trial #	Fc (MHz)	Pulse/Burst	Pulse Width (μS)	PRI (μs)	Detection (1:yes; 0:no)
1	5251	27	3.2	222	1
2	5251	26	2.6	155	1
3	5251	27	5	184	1
4	5251	28	2.6	213	1
5	5251	27	2.9	168	1
6	5251	23	2	203	1
7	5251	26	3.4	176	1
8	5251	23	1.5	197	1
9	5251	27	2.5	185	1
10	5251	25	1.7	223	1
11	5270	23	3.3	199	1
12	5270	23	2.8	168	1
13	5270	25	1.1	170	1
14	5270	26	4.6	163	1
15	5270	28	3	198	1
16	5270	29	3.4	224	1
17	5270	26	3.3	202	1
18	5270	27	3.1	180	1
19	5270	29	3.8	173	1
20	5270	28	1.7	174	1
21	5289	23	2.1	164	1
22	5289	27	3.4	150	1
23	5289	26	1.8	206	1
24	5289	24	3.6	229	1
25	5289	28	3.4	183	1
26	5289	28	1.6	176	1
27	5289	28	4.5	172	1
28	5289	24	1.4	200	1
29	5289	24	1.5	171	1
30	5289	27	3	211	1
Detection Percentage: 100 % (>60%)					

Table-3 Radar Type 3 Statistical Performance

Trial #	Fc (MHz)	Pulse/Burst	Pulse Width (μS)	PRI (μs)	Detection (1:yes; 0:no)
1	5251	16	9.2	435	1
2	5251	18	7.4	247	1
3	5251	18	9.4	222	1
4	5251	18	8.7	485	1
5	5251	17	7.5	419	1
6	5251	18	6.2	306	1
7	5251	16	8.9	423	1
8	5251	18	8.2	390	1
9	5251	17	9.3	343	1
10	5251	18	8.9	424	0
11	5270	18	9.5	229	1
12	5270	16	9.1	333	1
13	5270	16	8.7	315	1
14	5270	17	9.8	439	1
15	5270	16	9.6	262	1
16	5270	16	6.8	239	1
17	5270	17	6.3	202	1
18	5270	17	7.6	398	1
19	5270	18	6.4	350	1
20	5270	16	7.8	390	1
21	5289	16	9.7	204	1
22	5289	16	8.9	428	1
23	5289	18	6.8	371	1
24	5289	17	7.2	371	1
25	5289	18	6.1	375	1
26	5289	17	6.5	325	1
27	5289	16	7.4	401	1
28	5289	17	6.6	422	0
29	5289	18	8.6	251	1
30	5289	16	7.1	379	1
Detection Percentage: 93.33 % (>60%)					

Table-4 Radar Type 4 Statistical Performance

Trial #	Fc (MHz)	Pulse/Burst	Pulse Width (μS)	PRI (μs)	Detection (1:yes; 0:no)
1	5251	15	15.5	352	1
2	5251	12	12.3	416	1
3	5251	14	16.3	460	1
4	5251	14	19.7	378	1
5	5251	16	18.5	323	1
6	5251	13	12.5	266	1
7	5251	16	11.1	465	1
8	5251	12	11.1	484	1
9	5251	13	15.7	468	1
10	5251	12	19.7	368	1
11	5270	12	13.4	278	1
12	5270	15	16	382	1
13	5270	14	15.2	479	1
14	5270	12	19	206	1
15	5270	13	13.3	499	1
16	5270	16	16	405	1
17	5270	15	16.4	437	1
18	5270	12	20	248	1
19	5270	16	17.9	226	1
20	5270	15	19.8	231	1
21	5289	15	18.3	318	1
22	5289	12	14	360	1
23	5289	15	15.8	367	1
24	5289	16	13.6	468	1
25	5289	12	12	408	1
26	5289	12	19.7	314	1
27	5289	12	12.4	240	1
28	5289	16	12	335	1
29	5289	12	18	293	1
30	5289	12	12.1	268	1
Detection Percentage: 100 % (>60%)					

Table-5 Radar Type 5 Statistical Performance

Trial #	Fc (MHz)	Detection (1:yes; 0:no)
1	5270	1
2	5270	1
3	5270	1
4	5270	1
5	5270	1
6	5270	1
7	5270	1
8	5270	1
9	5270	1
10	5270	1
11	5256.2	1
12	5255.4	1
13	5256.6	1
14	5257.8	0
15	5257.4	1
16	5258.6	0
17	5257.8	0
18	5258.6	0
19	5255.0	1
20	5257.4	1
21	5284.2	1
22	8283.8	1
23	5283.0	1
24	5281.8	1
25	5287.0	1
26	5281.4	1
27	5284.2	1
28	5284.2	1
29	5281.4	1
30	5284.2	1
Detection Percentage: 86.67 % (>80%)		

Bin5 Statistics 1

Trial #	Pulse	Chirp (MHz)	Pulse Width (µS)	Pulse 1-2 spacing (uS)	Pulse 2-3 spacing (uS)	Pulse Start(S)	Detection (1:yes; 0:no)
0	3	12	68.4	1953	1397	0.223832	1
1	2	12	82.8	1741		0.920832	
2	2	12	68.6	1489		2.146111	
3	1	12	65.5			3.159292	
4	3	12	64.1	1660	1055	3.527866	
5	2	12	87.3	1992		4.490522	
6	2	12	77.7	1799		5.279768	
7	1	12	99.7			5.817789	
8	1	12	91.5			6.414698	
9	2	12	84.3	1409		7.50104	
10	3	12	93.3	1042	1048	8.375149	
11	2	12	76.3	1103		8.907617	
12	3	12	86.2	1483	1187	9.924365	
13	2	12	59.5	1296		10.517097	
14	2	12	56.2	1422		11.953973	

Bin5 Statistics 2

Trial #	Pulse	Chirp (MHz)	Pulse Width (µS)	Pulse 1-2 spacing (uS)	Pulse 2-3 spacing (uS)	Pulse Start(S)	Detection (1:yes; 0:no)
0	1	15	86.6			0.597203	1
1	3	15	85.2	1368	1688	1.620976	
2	2	15	92.9	1325		2.718276	
3	2	15	53.2	1493		3.091321	
4	3	15	64.4	1411	1306	3.847008	
5	3	15	93.7	1147	1941	4.8164	
6	3	15	86.5	1816	1143	5.896487	
7	2	15	50.2	1298		7.237553	
8	3	15	73	1878	1518	7.512634	
9	2	15	99.5	1180		8.727477	
10	1	15	63.4			9.249465	
11	2	15	55.2	1477		10.816608	
12	3	15	68.8	1445	1435	11.833028	

Bin5 Statistics 3

Trial #	Pulse	Chirp (MHz)	Pulse Width (µS)	Pulse 1-2 spacing (uS)	Pulse 2-3 spacing (uS)	Pulse Start(S)	Detection (1:yes; 0:no)
0	1	6	73.8			0.310533	1
1	2	6	70.7	1028		0.939409	
2	2	6	93.3	1089		1.820849	
3	2	6	76.4	1864		2.367842	
4	2	6	87.3	1298		3.720303	
5	1	6	63.7			3.867829	
6	2	6	61	1223		5.201299	
7	3	6	75.2	1464	1407	5.856982	
8	2	6	68.3	1319		6.228976	
9	3	6	61.9	1064	1317	6.757223	
10	2	6	63.5	1106		7.548937	
11	2	6	74.3	1641		8.310906	
12	2	6	52.4	1894		9.67955	
13	2	6	62.6	1876		10.180564	
14	2	6	59.5	1755		11.071871	
15	2	6	79.2	1625		11.945529	

Bin5 Statistics 4

Trial #	Pulse	Chirp (MHz)	Pulse Width (µS)	Pulse 1-2 spacing (uS)	Pulse 2-3 spacing (uS)	Pulse Start(S)	Detection (1:yes; 0:no)
0	2	14	97.7	1902		0.235182	1
1	2	14	75.7	1781		0.984826	
2	1	14	81			2.111703	
3	3	14	73.9	1676	1206	2.25864	
4	2	14	96.7	1864		3.052651	
5	3	14	81.3	1461	1876	3.819205	
6	2	14	54	1838		4.665366	
7	3	14	58.1	1042	1315	5.681523	
8	3	14	86.6	1361	1052	6.225538	
9	2	14	57.8	1455		7.220365	
10	2	14	53.8	1976		7.887401	
11	1	14	81.7			8.368701	
12	3	14	86.6	1572	1346	9.347846	
13	1	14	93.1			9.867868	
14	2	14	89.1	1682		10.744484	
15	2	14	82.9	1963		11.786428	

Bin5 Statistics 5

Trial #	Pulse	Chirp (MHz)	Pulse Width (μS)	Pulse 1-2 spacing (uS)	Pulse 2-3 spacing (uS)	Pulse Start(S)	Detection (1:yes; 0:no)
0	2	9	68.3	1178		0.607313	1
1	2	9	52.1	1952		0.988912	
2	1	9	78.1			1.927347	
3	3	9	75.2	1627	1931	2.605883	
4	2	9	77	1911		2.715657	
5	2	9	60.4	1639		3.867521	
6	2	9	89.4	1670		4.116533	
7	2	9	98.7	1243		5.025363	
8	2	9	75.5	1093		5.744965	
9	3	9	98.6	1201	1450	6.458949	
10	2	9	59.6	1287		6.787985	
11	2	9	61.7	1783		7.38909	
12	2	9	77.9	1041		8.459113	
13	2	9	97	1502		9.287694	
14	2	9	75.5	1569		9.937925	
15	2	9	64.9	1183		10.553249	
16	2	9	79.1	1875		10.703324	
17	1	9	64.4			11.417728	

Bin5 Statistics 6

Trial #	Pulse	Chirp (MHz)	Pulse Width (µS)	Pulse 1-2 spacing (uS)	Pulse 2-3 spacing (uS)	Pulse Start(S)	Detection (1:yes; 0:no)
0	1	6	99.5			0.577416	1
1	3	6	73.7	1892	1580	1.17577	
2	2	6	77.5	1460		1.794405	
3	2	6	83.5	1095		2.166615	
4	2	6	76.9	1918		3.25907	
5	2	6	59.8	1794		3.679499	
6	2	6	80.9	1618		4.900365	
7	2	6	88.5	1320		5.31142	
8	2	6	57.1	1871		5.851111	
9	2	6	79.9	1134		6.918424	
10	2	6	70.6	1932		7.630629	
11	3	6	95.5	1664	1862	8.357989	
12	2	6	66.8	1279		9.111972	
13	2	6	97	1135		9.508587	
14	1	6	55.8			10.134798	
15	2	6	56.1	1966		11.149752	
16	2	6	94.2	1344		11.42443	

Bin5 Statistics 7

Trial #	Pulse	Chirp (MHz)	Pulse Width (µS)	Pulse 1-2 spacing (uS)	Pulse 2-3 spacing (uS)	Pulse Start(S)	Detection (1:yes; 0:no)
0	2	15	96.2	1297		0.49279	1
1	2	15	55.6	1315		1.310662	
2	3	15	99.4	1794	1547	2.888735	
3	3	15	96.9	1401	1104	3.556212	
4	3	15	84.1	1330	1695	4.625516	
5	1	15	96.3			5.1704	
6	2	15	87.5	1634		6.962771	
7	3	15	94.5	1017	1146	7.14722	
8	2	15	70.9	1628		8.464176	
9	1	15	64.4			9.109111	
10	3	15	81.4	1441	1198	10.763658	
11	2	15	93.4	1806		11.953631	

Bin5 Statistics 8

Trial #	Pulse	Chirp (MHz)	Pulse Width (µS)	Pulse 1-2 spacing (uS)	Pulse 2-3 spacing (uS)	Pulse Start(S)	Detection (1:yes; 0:no)
0	1	7	75.7			0.237081	1
1	2	7	65.9	1381		1.129227	
2	2	7	94.8	1645		2.238227	
3	2	7	61	1586		2.52275	
4	2	7	79.5	1152		3.141931	
5	3	7	71.6	1754	1016	4.023209	
6	2	7	52.2	1075		4.574576	
7	2	7	78.1	1575		5.392058	
8	2	7	85.8	1968		6.4902	
9	3	7	59.5	1450	1733	6.899045	
10	3	7	61.5	1352	1915	7.572777	
11	2	7	77.1	1537		8.739885	
12	3	7	99.4	1466	1024	9.509054	
13	1	7	97			10.483409	
14	3	7	86.2	1600	1250	10.800534	
15	1	7	99.9			11.807727	

Bin5 Statistics 9

Trial #	Pulse	Chirp (MHz)	Pulse Width (µS)	Pulse 1-2 spacing (uS)	Pulse 2-3 spacing (uS)	Pulse Start(S)	Detection (1:yes; 0:no)
0	2	15	72.8	1044		0.650677	1
1	3	15	56.3	1795	1280	0.930804	
2	3	15	85.1	1611	1355	2.045356	
3	3	15	62.4	1361	1737	3.333682	
4	3	15	86.8	1817	1411	3.455656	
5	3	15	88.4	1007	1751	4.440258	
6	2	15	69.1	1894		5.396986	
7	3	15	76.5	1953	1206	6.467394	
8	2	15	94.8	1135		7.409016	
9	1	15	69.1			7.905033	
10	2	15	89.7	1091		9.287766	
11	2	15	61.7	1492		9.633966	
12	2	15	92.4	1685		10.950606	
13	2	15	94.4	1127		11.538056	

Bin5 Statistics 10

Trial #	Pulse	Chirp (MHz)	Pulse Width (µS)	Pulse 1-2 spacing (uS)	Pulse 2-3 spacing (uS)	Pulse Start(S)	Detection (1:yes; 0:no)
0	2	10	86.9	1247		0.759927	1
1	2	10	79.4	1932		1.717684	
2	1	10	98			2.641792	
3	1	10	84.7			3.686498	
4	2	10	92.8	1324		4.216483	
5	1	10	88.5			5.310535	
6	3	10	52.2	1261	1184	6.338204	
7	2	10	70.7	1645		6.479785	
8	3	10	56.1	1859	1754	8.127162	
9	2	10	68.7	1768		8.859569	
10	3	10	50.6	1514	1013	9.760484	
11	2	10	79.6	1628		11.012008	
12	2	10	89.7	1165		11.637238	

Bin5 Statistics 11

Trial #	Pulse	Chirp (MHz)	Pulse Width (µS)	Pulse 1-2 spacing (uS)	Pulse 2-3 spacing (uS)	Pulse Start(S)	Detection (1:yes; 0:no)
0	2	13	82.4	1376		0.477325	1
1	2	13	99.7	1969		1.979985	
2	2	13	55.2	1663		3.077769	
3	1	13	86.8			4.721529	
4	2	13	65.9	1080		5.755217	
5	2	13	57.8	1265		6.465801	
6	1	13	54.2			8.293627	
7	2	13	84.4	1545		9.16294	
8	3	13	64.8	1449	1744	9.61117	
9	1	13	52.1			11.990168	

Bin5 Statistics 12

Trial #	Pulse	Chirp (MHz)	Pulse Width (µS)	Pulse 1-2 spacing (uS)	Pulse 2-3 spacing (uS)	Pulse Start(S)	Detection (1:yes; 0:no)
0	2	11	83.6	1012		0.424469	1
1	1	11	69.7			1.562589	
2	3	11	95.3	1167	1285	2.385494	
3	1	11	74.8			2.578332	
4	2	11	66.4	1293		3.583345	
5	2	11	75	1083		4.290325	
6	3	11	99.8	1114	1142	5.499595	
7	1	11	90.2			6.17947	
8	2	11	65.7	1951		6.404033	
9	2	11	59.2	1847		7.956041	
10	1	11	84.6			8.277001	
11	3	11	70.1	1854	1176	9.509319	
12	2	11	81	1045		10.384789	
13	2	11	64.2	1451		10.411676	
14	2	11	93.2	1967		11.63089	

Bin5 Statistics 13

Trial #	Pulse	Chirp (MHz)	Pulse Width (uS)	Pulse 1-2 spacing (uS)	Pulse 2-3 spacing (uS)	Pulse Start(S)	Detection (1:yes; 0:no)
0	2	14	94	1560		0.078593	1
1	3	14	70.1	1577	1336	0.965059	
2	2	14	66.3	1540		1.43309	
3	2	14	95.8	1960		1.928542	
4	2	14	69.3	1287		2.782184	
5	3	14	66.8	1251	1694	3.369254	
6	1	14	58.9			4.000824	
7	3	14	64.3	1319	1198	4.603588	
8	1	14	54.5			5.227308	
9	1	14	62.6			5.461115	
10	1	14	98.6			6.416982	
11	1	14	61			6.891844	
12	2	14	97.6	1995		7.746154	
13	1	14	86.2			8.246101	
14	3	14	66.9	1493	1224	8.486984	
15	2	14	82	1989		9.528612	
16	2	14	87	1079		9.719354	
17	2	14	79.1	1528		10.616298	
18	2	14	60.5	1509		10.835533	
19	2	14	93.2	1117		11.892455	

Bin5 Statistics 14

Trial #	Pulse	Chirp (MHz)	Pulse Width (µS)	Pulse 1-2 spacing (uS)	Pulse 2-3 spacing (uS)	Pulse Start(S)	Detection (1:yes; 0:no)
0	2	17	78.2	1940		0.415966	0
1	2	17	57.7	1672		0.905228	
2	1	17	90.2			1.924103	
3	2	17	54.7	1585		2.74057	
4	3	17	88	1866	1434	3.906468	
5	2	17	77.8	1119		4.126032	
6	1	17	98.6			5.126396	
7	2	17	94.6	1691		5.686564	
8	2	17	95	1730		6.582111	
9	1	17	69.4			7.576634	
10	1	17	68.6			8.04094	
11	2	17	86.9	1911		8.8741	
12	2	17	65.1	1094		9.751214	
13	2	17	68.2	1776		10.557397	
14	2	17	81.9	1854		11.826984	

Bin5 Statistics 15

Trial #	Pulse	Chirp (MHz)	Pulse Width (µS)	Pulse 1-2 spacing (uS)	Pulse 2-3 spacing (uS)	Pulse Start(S)	Detection (1:yes; 0:no)
0	2	16	74.8	1911		0.566873	1
1	2	16	64.8	1466		1.825142	
2	2	16	98.7	1018		1.957287	
3	3	16	69.5	1567	1117	3.50112	
4	2	16	94.2	1045		4.188056	
5	2	16	81.5	1443		4.964058	
6	1	16	92.6			5.646797	
7	2	16	89	1779		6.463454	
8	1	16	91			8.273539	
9	3	16	90.2	1889	1270	8.961243	
10	3	16	98	1100	1060	9.388459	
11	1	16	86.7			10.521692	
12	2	16	72.7	1727		11.587649	

Bin5 Statistics 16

Trial #	Pulse	Chirp (MHz)	Pulse Width (µS)	Pulse 1-2 spacing (µS)	Pulse 2-3 spacing (µS)	Pulse Start(S)	Detection (1:yes; 0:no)
0	2	19	52.1	1904		0.547333	0
1	2	19	87.7	1314		1.112614	
2	1	19	92.7			1.820044	
3	3	19	70.8	1505	1261	2.379554	
4	2	19	97.4	1840		3.301221	
5	1	19	89.6			4.403613	
6	2	19	96	1780		5.23807	
7	3	19	86.1	1903	1786	5.327208	
8	1	19	62.4			6.648974	
9	2	19	89.9	1593		7.14674	
10	1	19	53.2			7.500355	
11	3	19	99.5	1663	1284	8.452338	
12	2	19	88.7	1536		9.438355	
13	2	19	88.6	1601		10.018494	
14	2	19	97.7	1159		10.634063	
15	2	19	91.1	1164		11.688106	

Bin5 Statistics 17

Trial #	Pulse	Chirp (MHz)	Pulse Width (µS)	Pulse 1-2 spacing (µS)	Pulse 2-3 spacing (µS)	Pulse Start(S)	Detection (1:yes; 0:no)
0	3	17	69.7	1397	1575	0.196716	0
1	3	17	66.6	1425	1377	1.395327	
2	1	17	71.7			2.366006	
3	2	17	61.8	1690		3.015007	
4	2	17	68.6	1621		3.899809	
5	1	17	97.4			5.128568	
6	3	17	97.2	1800	1320	5.361012	
7	3	17	69.3	1229	1571	6.358125	
8	2	17	60.2	1241		7.057391	
9	2	17	63	1648		8.089145	
10	3	17	71.8	1345	1981	8.845397	
11	3	17	88	1435	1529	10.088862	
12	2	17	60.8	1070		10.761884	
13	1	17	63.2			11.510961	

Bin5 Statistics 18

Trial #	Pulse	Chirp (MHz)	Pulse Width (µS)	Pulse 1-2 spacing (uS)	Pulse 2-3 spacing (uS)	Pulse Start(S)	Detection (1:yes; 0:no)
0	1	19	55.1			0.390895	0
1	3	19	74.5	1006	1775	2.169877	
2	3	19	82.5	1486	1781	2.890908	
3	1	19	74.3			4.307035	
4	1	19	92			5.379116	
5	2	19	95.9	1536		7.262487	
6	2	19	84.6	1102		9.285314	
7	2	19	64.3	1723		10.345502	
8	2	19	71.1	1233		10.67411	

Bin5 Statistics 19

Trial #	Pulse	Chirp (MHz)	Pulse Width (µS)	Pulse 1-2 spacing (uS)	Pulse 2-3 spacing (uS)	Pulse Start(S)	Detection (1:yes; 0:no)
0	2	10	62.4	1904		0.575437	1
1	1	10	90.3			0.663509	
2	3	10	91.5	1431	1595	1.333984	
3	3	10	69.6	1755	1859	1.936301	
4	2	10	81.7	1275		2.713206	
5	3	10	54.1	1277	1568	3.414736	
6	2	10	65.3	1313		3.818482	
7	2	10	58.8	1637		4.869721	
8	2	10	67	1801		5.323316	
9	1	10	96.7			5.761924	
10	1	10	72.9			6.88618	
11	1	10	60.3			7.419513	
12	2	10	51.8	1325		7.97078	
13	2	10	81.8	1550		8.499998	
14	2	10	65.8	1769		9.100741	
15	2	10	90	1578		9.730658	
16	1	10	51			10.349555	
17	2	10	66.1	1995		10.967683	
18	3	10	95.8	1553	1013	11.762269	

Bin5 Statistics 20

Trial #	Pulse	Chirp (MHz)	Pulse Width (µS)	Pulse 1-2 spacing (uS)	Pulse 2-3 spacing (uS)	Pulse Start(S)	Detection (1:yes; 0:no)
0	2	16	86.3	1159		0.83731	1
1	2	16	62	1300		2.016433	
2	3	16	58.5	1021	1499	2.836797	
3	1	16	82.4			4.511917	
4	2	16	86.4	1020		5.379916	
5	1	16	52.1			6.562701	
6	3	16	66.5	1826	1177	8.109339	
7	3	16	76.8	1478	1298	8.498735	
8	2	16	83.2	1398		9.810337	
9	3	16	90.8	1164	1295	11.148227	

Bin5 Statistics 21

Trial #	Pulse	Chirp (MHz)	Pulse Width (µS)	Pulse 1-2 spacing (uS)	Pulse 2-3 spacing (uS)	Pulse Start(S)	Detection (1:yes; 0:no)
0	1	12	63.8			1.055504	1
1	2	12	54.5	1715		1.328809	
2	2	12	90.1	1969		2.302427	
3	1	12	93.2			3.534254	
4	2	12	67	1540		4.76665	
5	3	12	75.8	1702	1682	5.724611	
6	3	12	70.3	1504	1933	6.812376	
7	2	12	95.6	1579		7.911472	
8	2	12	71.6	1874		9.104644	
9	2	12	71.9	1616		10.012671	
10	1	12	69.8			11.609621	

Bin5 Statistics 22

Trial #	Pulse	Chirp (MHz)	Pulse Width (µS)	Pulse 1-2 spacing (uS)	Pulse 2-3 spacing (uS)	Pulse Start(S)	Detection (1:yes; 0:no)
0	2	13	98.3	1068		0.007889	1
1	3	13	82.8	1255	1813	0.98812	
2	2	13	71.2	1534		1.805049	
3	2	13	89.8	1011		2.61044	
4	1	13	71.8			3.389773	
5	2	13	75.5	1389		3.712038	
6	2	13	68.9	1685		4.531526	
7	1	13	70.2			4.993419	
8	1	13	82.9			5.693643	
9	2	13	54.4	1294		6.874272	
10	1	13	72.8			7.523047	
11	3	13	91.4	1986	1370	8.042877	
12	1	13	71.5			9.075196	
13	1	13	83.3			9.414417	
14	2	13	83.6	1176		9.884746	
15	1	13	68.1			10.642166	
16	1	13	93			11.342634	

Bin5 Statistics 23

Trial #	Pulse	Chirp (MHz)	Pulse Width (uS)	Pulse 1-2 spacing (uS)	Pulse 2-3 spacing (uS)	Pulse Start(S)	Detection (1:yes; 0:no)
0	3	15	70.3	1859	1985	0.02046	1
1	3	15	97.4	1505	1493	0.75738	
2	2	15	67.2	1779		1.236727	
3	2	15	59.8	1051		1.820536	
4	1	15	79			2.940662	
5	2	15	95.4	1438		3.580688	
6	2	15	55.4	1617		4.083798	
7	1	15	82.5			4.228487	
8	3	15	71.1	1441	1949	5.208284	
9	2	15	86.4	1895		5.527779	
10	2	15	78.7	1203		6.309506	
11	3	15	77.3	1177	1860	7.153507	
12	1	15	96.9			7.601288	
13	1	15	67.6			8.139914	
14	2	15	89.2	1066		8.828212	
15	3	15	57.5	1771	1345	9.097499	
16	2	15	62.7	1258		9.623891	
17	2	15	89.1	1870		10.790086	
18	2	15	89.3	1986		11.293642	
19	1	15	82.2			11.760347	

Bin5 Statistics 24

Trial #	Pulse	Chirp (MHz)	Pulse Width (uS)	Pulse 1-2 spacing (uS)	Pulse 2-3 spacing (uS)	Pulse Start(S)	Detection (1:yes; 0:no)
0	2	18	64	1543		0.130756	1
1	3	18	71.7	1560	1564	1.04696	
2	2	18	74.1	1911		2.206002	
3	2	18	78.8	1004		3.975167	
4	2	18	86.1	1539		4.481821	
5	2	18	58.6	1776		5.606847	
6	3	18	54.8	1465	1869	6.902	
7	2	18	93.4	1117		7.75955	
8	1	18	87.7			8.705818	
9	3	18	51.8	1759	1320	9.852125	
10	2	18	81.8	1828		10.709415	
11	3	18	94.9	1222	1815	11.196385	

Bin5 Statistics 25

Trial #	Pulse	Chirp (MHz)	Pulse Width (µS)	Pulse 1-2 spacing (µS)	Pulse 2-3 spacing (µS)	Pulse Start(S)	Detection (1:yes; 0:no)
0	2	5	76.1	1006		0.06557	1
1	1	5	97.9			0.662428	
2	1	5	69.5			1.492468	
3	1	5	55.4			2.332234	
4	2	5	79.5	1141		3.079808	
5	2	5	61.8	1360		3.367992	
6	3	5	83.3	1487	1588	4.034179	
7	3	5	62.7	1394	1702	4.62135	
8	2	5	68	1444		5.650873	
9	2	5	63.8	1372		5.689606	
10	3	5	88.8	1811	1330	6.45911	
11	3	5	73.2	1487	1280	7.01813	
12	2	5	86.8	1587		7.775134	
13	1	5	70.7			8.588489	
14	2	5	85.7	1572		9.227503	
15	2	5	80.7	1034		9.973745	
16	2	5	80.6	1787		10.685139	
17	1	5	92.8			11.174237	
18	1	5	72.4			11.639028	

Bin5 Statistics 26

Trial #	Pulse	Chirp (MHz)	Pulse Width (µS)	Pulse 1-2 spacing (µS)	Pulse 2-3 spacing (µS)	Pulse Start(S)	Detection (1:yes; 0:no)
0	2	19	78.4	1576		0.459633	1
1	2	19	77.3	1923		0.885313	
2	2	19	84.4	1255		1.662021	
3	2	19	74.9	1831		2.592536	
4	2	19	60.4	1868		3.015926	
5	3	19	97.4	1345	1536	3.846021	
6	3	19	69.7	1518	1397	4.636882	
7	2	19	50.2	1941		4.768024	
8	1	19	66.8			5.361897	
9	2	19	89.2	1177		6.111223	
10	1	19	80.5			6.710699	
11	2	19	80.5	1576		7.562703	
12	2	19	90.4	1236		8.445853	
13	2	19	94	1747		8.696899	
14	1	19	73.5			9.546675	
15	2	19	52	1084		10.545796	
16	3	19	97.6	1384	1395	10.940933	
17	3	19	74	1962	1812	11.714911	

Bin5 Statistics 27

Trial #	Pulse	Chirp (MHz)	Pulse Width (µS)	Pulse 1-2 spacing (µS)	Pulse 2-3 spacing (µS)	Pulse Start(S)	Detection (1:yes; 0:no)
0	3	12	87.7	1697	1547	0.149939	1
1	2	12	88.2	1931		1.098098	
2	3	12	70.6	1076	1305	2.948182	
3	1	12	64.9			3.342628	
4	2	12	76.4	1579		4.835596	
5	1	12	74.8			5.012613	
6	2	12	68.8	1000		6.246597	
7	1	12	54			7.304107	
8	1	12	91.5			8.609028	
9	1	12	81.6			9.120385	
10	2	12	51.6	1420		10.495433	
11	1	12	97.6			11.348766	

Bin5 Statistics 28

Trial #	Pulse	Chirp (MHz)	Pulse Width (µS)	Pulse 1-2 spacing (uS)	Pulse 2-3 spacing (uS)	Pulse Start(S)	Detection (1:yes; 0:no)
0	2	12	93.1	1881		1.073653	1
1	2	12	89.3	1988		2.145566	
2	2	12	61.3	1609		2.438431	
3	3	12	93.4	1010	1836	3.731864	
4	3	12	53.8	1152	1308	5.189504	
5	2	12	87.6	1770		5.466479	
6	2	12	75.1	1133		7.439791	
7	2	12	60.7	1639		7.956251	
8	3	12	76.3	1688	1929	8.989585	
9	3	12	64.1	1551	1453	10.139283	
10	2	12	78.4	1936		11.564851	

Bin5 Statistics 29

Trial #	Pulse	Chirp (MHz)	Pulse Width (µS)	Pulse 1-2 spacing (uS)	Pulse 2-3 spacing (uS)	Pulse Start(S)	Detection (1:yes; 0:no)
0	2	19	65.1	1415		0.411894	1
1	2	19	90.4	1275		0.758224	
2	2	19	94.5	1689		1.71109	
3	2	19	61.1	1057		2.966132	
4	2	19	69.6	1332		3.643155	
5	1	19	74.3			4.374959	
6	1	19	77.9			4.859947	
7	1	19	52.7			5.39424	
8	3	19	61.1	1393	1069	6.403163	
9	1	19	69.4			7.282922	
10	1	19	65			7.934335	
11	2	19	64.2	1522		8.79495	
12	2	19	88.3	1258		9.468633	
13	2	19	68.5	1892		10.059101	
14	3	19	56.2	1428	1597	10.853642	
15	3	19	63.9	1369	1550	11.529632	

Bin5 Statistics 30

Trial #	Pulse	Chirp (MHz)	Pulse Width (µS)	Pulse 1-2 spacing (µS)	Pulse 2-3 spacing (µS)	Pulse Start(S)	Detection (1:yes; 0:no)
0	1	12	61.4			0.092864	1
1	1	12	71.6			1.105218	
2	3	12	72.8	1200	1506	2.097747	
3	2	12	96.9	1041		2.387303	
4	1	12	70.6			3.212376	
5	3	12	89.4	1057	1654	4.189882	
6	1	12	92.5			4.872214	
7	3	12	92.5	1847	1718	5.940129	
8	3	12	95.6	1557	1706	6.511739	
9	2	12	57.5	1010		7.310206	
10	2	12	72.7	1618		8.048668	
11	1	12	51.9			8.800645	
12	3	12	67.4	1445	1936	9.277122	
13	1	12	69.4			10.165719	
14	2	12	85.1	1373		10.636907	
15	2	12	76.4	1369		11.965298	

Table-6 Radar Type 6 Statistical Performance

Trial #	Fc (MHz)	Pulse /Burst	Pulse Width (µS)	PRI (µs)	Detection (1:yes; 0:no)	Hopping Sequence
1	5250	9	1	333	1	5419.0, 5599.0, 5666.0, 5384.0, 5549.0, 5606.0, 5254.0, 5325.0, 5704.0, 5359.0, 5336.0, 5268.0, 5667.0, 5429.0, 5618.0, 5560.0, 5574.0, 5381.0, 5455.0, 5364.0, 5432.0, 5469.0, 5625.0, 5578.0, 5323.0, 5344.0, 5573.0, 5411.0, 5303.0, 5401.0, 5483.0, 5522.0, 5613.0, 5277.0, 5520.0, 5513.0, 5689.0, 5592.0, 5373.0, 5375.0, 5367.0, 5476.0, 5492.0, 5572.0, 5525.0, 5504.0, 5440.0, 5340.0, 5569.0, 5421.0, 5427.0, 5491.0, 5535.0, 5383.0, 5449.0, 5537.0, 5539.0, 5350.0, 5289.0, 5434.0, 5256.0, 5292.0, 5272.0, 5423.0, 5602.0, 5282.0, 5697.0, 5612.0, 5593.0, 5632.0, 5283.0, 5402.0, 5415.0, 5614.0, 5685.0, 5400.0, 5598.0, 5403.0, 5428.0, 5302.0, 5315.0, 5284.0, 5259.0, 5687.0, 5720.0, 5597.0, 5516.0, 5370.0, 5335.0, 5589.0, 5524.0, 5588.0, 5404.0, 5371.0, 5683.0, 5626.0, 5459.0, 5681.0, 5548.0, 5454.0 (number of hits: 4)
2	5250	9	1	333	1	5292.0, 5294.0, 5512.0, 5596.0, 5570.0, 5676.0, 5462.0, 5367.0, 5447.0, 5620.0, 5254.0, 5562.0, 5365.0, 5345.0, 5452.0, 5428.0, 5601.0, 5420.0, 5318.0, 5473.0, 5355.0, 5671.0, 5668.0, 5485.0, 5675.0, 5395.0, 5507.0, 5628.0, 5565.0, 5409.0, 5267.0, 5559.0, 5677.0, 5317.0, 5310.0, 5372.0, 5286.0, 5717.0, 5378.0, 5404.0, 5536.0, 5479.0, 5713.0, 5466.0, 5382.0, 5642.0, 5261.0, 5401.0, 5719.0, 5492.0, 5288.0, 5302.0, 5321.0, 5282.0, 5690.0, 5283.0, 5396.0, 5636.0, 5656.0, 5301.0, 5592.0, 5674.0, 5362.0, 5718.0, 5341.0, 5567.0, 5389.0, 5597.0, 5711.0, 5319.0, 5438.0, 5631.0, 5681.0, 5581.0, 5263.0, 5418.0, 5577.0, 5521.0, 5693.0, 5460.0, 5411.0, 5669.0, 5439.0, 5440.0, 5453.0, 5673.0, 5347.0, 5361.0, 5595.0, 5400.0, 5699.0, 5380.0, 5359.0, 5271.0, 5437.0, 5701.0, 5307.0, 5563.0, 5304.0, 5687.0 (number of hits: 4)
3	5250	9	1	333	1	5336.0, 5260.0, 5686.0, 5703.0, 5684.0, 5307.0, 5403.0, 5382.0, 5633.0, 5553.0, 5723.0, 5540.0, 5524.0, 5606.0, 5566.0, 5557.0, 5679.0, 5724.0, 5519.0, 5448.0, 5333.0, 5322.0, 5280.0, 5688.0, 5472.0, 5439.0, 5665.0, 5445.0, 5303.0, 5484.0, 5348.0, 5527.0, 5502.0, 5278.0, 5668.0, 5385.0, 5528.0, 5693.0, 5368.0, 5496.0, 5419.0, 5671.0, 5428.0, 5590.0, 5437.0, 5538.0, 5681.0, 5361.0, 5663.0, 5486.0, 5593.0, 5455.0, 5701.0, 5400.0, 5379.0, 5252.0, 5506.0, 5625.0, 5343.0, 5284.0,

						5653.0, 5464.0, 5672.0, 5443.0, 5715.0, 5657.0, 5285.0, 5318.0, 5645.0, 5286.0, 5329.0, 5515.0, 5429.0, 5291.0, 5425.0, 5256.0, 5615.0, 5576.0, 5264.0, 5373.0, 5650.0, 5270.0, 5542.0, 5622.0, 5623.0, 5525.0, 5258.0, 5718.0, 5594.0, 5694.0, 5562.0, 5372.0, 5680.0, 5405.0, 5359.0, 5702.0, 5417.0, 5610.0, 5697.0, 5550.0 (number of hits: 5)
4	5250	9	1	333	1	5661.0, 5547.0, 5465.0, 5378.0, 5572.0, 5687.0, 5704.0, 5457.0, 5277.0, 5278.0, 5515.0, 5543.0, 5646.0, 5507.0, 5468.0, 5544.0, 5444.0, 5289.0, 5251.0, 5260.0, 5440.0, 5529.0, 5300.0, 5708.0, 5317.0, 5481.0, 5461.0, 5546.0, 5504.0, 5715.0, 5453.0, 5710.0, 5693.0, 5520.0, 5419.0, 5669.0, 5614.0, 5422.0, 5439.0, 5508.0, 5718.0, 5583.0, 5633.0, 5336.0, 5509.0, 5399.0, 5671.0, 5625.0, 5297.0, 5302.0, 5603.0, 5649.0, 5253.0, 5344.0, 5613.0, 5523.0, 5641.0, 5579.0, 5695.0, 5596.0, 5428.0, 5405.0, 5390.0, 5680.0, 5447.0, 5438.0, 5542.0, 5562.0, 5610.0, 5275.0, 5688.0, 5655.0, 5498.0, 5454.0, 5510.0, 5518.0, 5272.0, 5590.0, 5382.0, 5683.0, 5690.0, 5256.0, 5559.0, 5456.0, 5298.0, 5554.0, 5531.0, 5587.0, 5322.0, 5432.0, 5615.0, 5618.0, 5364.0, 5474.0, 5679.0, 5424.0, 5709.0, 5284.0, 5616.0, 5573.0 (number of hits: 4)
5	5250	9	1	333	1	5329.0, 5646.0, 5613.0, 5436.0, 5682.0, 5373.0, 5596.0, 5439.0, 5485.0, 5438.0, 5623.0, 5256.0, 5379.0, 5287.0, 5284.0, 5510.0, 5541.0, 5483.0, 5554.0, 5520.0, 5313.0, 5324.0, 5293.0, 5624.0, 5312.0, 5430.0, 5440.0, 5721.0, 5328.0, 5252.0, 5683.0, 5582.0, 5424.0, 5467.0, 5674.0, 5306.0, 5384.0, 5584.0, 5603.0, 5712.0, 5644.0, 5280.0, 5663.0, 5659.0, 5546.0, 5392.0, 5482.0, 5319.0, 5628.0, 5607.0, 5600.0, 5274.0, 5662.0, 5650.0, 5325.0, 5594.0, 5580.0, 5431.0, 5295.0, 5473.0, 5401.0, 5477.0, 5593.0, 5505.0, 5442.0, 5380.0, 5341.0, 5565.0, 5653.0, 5686.0, 5456.0, 5349.0, 5536.0, 5282.0, 5393.0, 5577.0, 5615.0, 5668.0, 5398.0, 5524.0, 5410.0, 5516.0, 5522.0, 5705.0, 5697.0, 5301.0, 5493.0, 5553.0, 5568.0, 5358.0, 5255.0, 5355.0, 5446.0, 5715.0, 5478.0, 5466.0, 5649.0, 5704.0, 5263.0, 5428.0 (number of hits: 4)
6	5250	9	1	333	1	5689.0, 5307.0, 5346.0, 5681.0, 5707.0, 5396.0, 5302.0, 5336.0, 5506.0, 5578.0, 5607.0, 5304.0, 5469.0, 5331.0, 5646.0, 5462.0, 5348.0, 5524.0, 5281.0, 5441.0, 5716.0, 5366.0, 5386.0, 5303.0, 5710.0, 5374.0, 5602.0, 5478.0, 5544.0, 5500.0, 5505.0, 5450.0, 5341.0, 5686.0, 5674.0, 5623.0, 5597.0, 5422.0, 5361.0, 5273.0, 5711.0, 5463.0, 5625.0, 5476.0, 5349.0, 5562.0, 5724.0, 5661.0, 5621.0, 5458.0

						5518.0, 5595.0, 5387.0, 5295.0, 5380.0, 5519.0, 5368.0, 5636.0, 5390.0, 5445.0, 5293.0, 5620.0, 5522.0, 5648.0, 5481.0, 5383.0, 5691.0, 5286.0, 5719.0, 5311.0, 5569.0, 5388.0, 5403.0, 5606.0, 5579.0, 5502.0, 5355.0, 5542.0, 5473.0, 5627.0, 5382.0, 5694.0, 5456.0, 5365.0, 5334.0, 5314.0, 5483.0, 5436.0, 5501.0, 5447.0, 5615.0, 5358.0, 5391.0, 5398.0, 5696.0, 5465.0, 5585.0, 5484.0, 5266.0, 5610.0 (number of hits: 1)
7	5250	9	1	333	1	5303.0, 5538.0, 5603.0, 5440.0, 5670.0, 5264.0, 5370.0, 5478.0, 5255.0, 5581.0, 5418.0, 5431.0, 5441.0, 5481.0, 5542.0, 5705.0, 5528.0, 5413.0, 5433.0, 5642.0, 5459.0, 5652.0, 5657.0, 5679.0, 5545.0, 5624.0, 5415.0, 5256.0, 5327.0, 5263.0, 5702.0, 5396.0, 5367.0, 5498.0, 5456.0, 5715.0, 5335.0, 5294.0, 5267.0, 5627.0, 5410.0, 5336.0, 5426.0, 5253.0, 5467.0, 5712.0, 5504.0, 5388.0, 5540.0, 5701.0, 5461.0, 5693.0, 5522.0, 5409.0, 5260.0, 5628.0, 5322.0, 5318.0, 5300.0, 5475.0, 5668.0, 5265.0, 5721.0, 5688.0, 5353.0, 5394.0, 5660.0, 5458.0, 5308.0, 5709.0, 5279.0, 5365.0, 5532.0, 5297.0, 5412.0, 5669.0, 5600.0, 5366.0, 5351.0, 5549.0, 5557.0, 5448.0, 5513.0, 5251.0, 5505.0, 5515.0, 5250.0, 5547.0, 5604.0, 5314.0, 5533.0, 5589.0, 5646.0, 5398.0, 5492.0, 5537.0, 5665.0, 5385.0, 5482.0, 5518.0 (number of hits: 10)
8	5250	9	1	333	1	5386.0, 5448.0, 5681.0, 5529.0, 5301.0, 5574.0, 5682.0, 5439.0, 5557.0, 5372.0, 5411.0, 5349.0, 5662.0, 5353.0, 5387.0, 5370.0, 5657.0, 5413.0, 5359.0, 5477.0, 5704.0, 5464.0, 5601.0, 5414.0, 5393.0, 5583.0, 5697.0, 5295.0, 5656.0, 5277.0, 5481.0, 5520.0, 5720.0, 5518.0, 5424.0, 5651.0, 5267.0, 5261.0, 5276.0, 5388.0, 5482.0, 5435.0, 5519.0, 5572.0, 5307.0, 5573.0, 5500.0, 5635.0, 5499.0, 5547.0, 5292.0, 5336.0, 5695.0, 5610.0, 5711.0, 5459.0, 5416.0, 5638.0, 5530.0, 5622.0, 5426.0, 5319.0, 5417.0, 5455.0, 5508.0, 5676.0, 5579.0, 5541.0, 5590.0, 5401.0, 5361.0, 5689.0, 5330.0, 5352.0, 5300.0, 5598.0, 5605.0, 5597.0, 5260.0, 5694.0, 5294.0, 5432.0, 5288.0, 5688.0, 5308.0, 5262.0, 5309.0, 5335.0, 5713.0, 5273.0, 5640.0, 5458.0, 5507.0, 5501.0, 5475.0, 5357.0, 5311.0, 5663.0, 5400.0, 5708.0 (number of hits: 4)
9	5250	9	1	333	1	5293.0, 5546.0, 5277.0, 5684.0, 5521.0, 5412.0, 5709.0, 5409.0, 5677.0, 5402.0, 5520.0, 5686.0, 5719.0, 5539.0, 5452.0, 5616.0, 5266.0, 5608.0, 5631.0, 5408.0, 5708.0, 5636.0, 5470.0, 5450.0, 5384.0, 5270.0, 5701.0, 5285.0, 5486.0, 5327.0, 5529.0, 5353.0, 5260.0, 5487.0, 5564.0, 5572.0, 5374.0, 5697.0, 5361.0, 5626.0,

						5414.0, 5682.0, 5671.0, 5399.0, 5676.0, 5705.0, 5575.0, 5338.0, 5657.0, 5619.0, 5551.0, 5534.0, 5456.0, 5598.0, 5557.0, 5313.0, 5369.0, 5581.0, 5580.0, 5423.0, 5536.0, 5640.0, 5589.0, 5349.0, 5279.0, 5256.0, 5615.0, 5289.0, 5464.0, 5308.0, 5330.0, 5498.0, 5299.0, 5548.0, 5401.0, 5517.0, 5340.0, 5508.0, 5635.0, 5656.0, 5347.0, 5691.0, 5291.0, 5621.0, 5400.0, 5364.0, 5422.0, 5613.0, 5604.0, 5360.0, 5319.0, 5395.0, 5397.0, 5269.0, 5392.0, 5296.0, 5390.0, 5610.0, 5541.0, 5484.0 (number of hits: 4)
10	5250	9	1	333	1	5654.0, 5304.0, 5254.0, 5478.0, 5468.0, 5561.0, 5648.0, 5345.0, 5656.0, 5352.0, 5562.0, 5435.0, 5566.0, 5267.0, 5418.0, 5533.0, 5361.0, 5515.0, 5346.0, 5392.0, 5260.0, 5625.0, 5582.0, 5259.0, 5509.0, 5398.0, 5718.0, 5404.0, 5559.0, 5342.0, 5299.0, 5567.0, 5451.0, 5526.0, 5334.0, 5476.0, 5624.0, 5292.0, 5660.0, 5318.0, 5285.0, 5554.0, 5416.0, 5644.0, 5426.0, 5695.0, 5325.0, 5700.0, 5543.0, 5569.0, 5356.0, 5475.0, 5615.0, 5289.0, 5442.0, 5699.0, 5620.0, 5483.0, 5596.0, 5555.0, 5372.0, 5330.0, 5464.0, 5723.0, 5702.0, 5336.0, 5692.0, 5359.0, 5523.0, 5363.0, 5264.0, 5681.0, 5708.0, 5331.0, 5393.0, 5394.0, 5572.0, 5628.0, 5472.0, 5473.0, 5711.0, 5594.0, 5339.0, 5590.0, 5546.0, 5368.0, 5310.0, 5680.0, 5581.0, 5529.0, 5542.0, 5482.0, 5365.0, 5634.0, 5496.0, 5298.0, 5494.0, 5653.0, 5490.0, 5611.0 (number of hits: 5)
11	5270	9	1	333	1	5298.0, 5605.0, 5558.0, 5418.0, 5722.0, 5346.0, 5399.0, 5652.0, 5556.0, 5422.0, 5488.0, 5520.0, 5631.0, 5654.0, 5375.0, 5717.0, 5569.0, 5395.0, 5278.0, 5344.0, 5701.0, 5522.0, 5354.0, 5321.0, 5601.0, 5590.0, 5540.0, 5650.0, 5680.0, 5535.0, 5610.0, 5524.0, 5436.0, 5705.0, 5360.0, 5376.0, 5506.0, 5670.0, 5536.0, 5297.0, 5361.0, 5264.0, 5509.0, 5303.0, 5567.0, 5438.0, 5286.0, 5542.0, 5573.0, 5551.0, 5686.0, 5711.0, 5427.0, 5284.0, 5672.0, 5611.0, 5602.0, 5359.0, 5491.0, 5476.0, 5580.0, 5667.0, 5272.0, 5543.0, 5703.0, 5581.0, 5534.0, 5434.0, 5252.0, 5407.0, 5607.0, 5285.0, 5279.0, 5671.0, 5498.0, 5594.0, 5697.0, 5499.0, 5505.0, 5465.0, 5662.0, 5370.0, 5458.0, 5368.0, 5358.0, 5442.0, 5560.0, 5664.0, 5342.0, 5318.0, 5443.0, 5599.0, 5634.0, 5250.0, 5723.0, 5347.0, 5521.0, 5402.0, 5547.0, 5302.0 (number of hits: 9)
12	5270	9	1	333	1	5419.0, 5358.0, 5468.0, 5697.0, 5602.0, 5585.0, 5343.0, 5695.0, 5259.0, 5407.0, 5701.0, 5442.0, 5307.0, 5571.0, 5428.0, 5500.0, 5582.0, 5454.0, 5286.0, 5370.0, 5675.0, 5528.0, 5561.0, 5603.0, 5345.0, 5644.0, 5504.0, 5676.0, 5443.0, 5482.0,

						5597.0, 5302.0, 5524.0, 5261.0, 5339.0, 5491.0, 5467.0, 5522.0, 5477.0, 5673.0, 5535.0, 5465.0, 5359.0, 5316.0, 5344.0, 5383.0, 5669.0, 5460.0, 5263.0, 5309.0, 5432.0, 5414.0, 5397.0, 5714.0, 5284.0, 5503.0, 5682.0, 5551.0, 5425.0, 5462.0, 5586.0, 5613.0, 5573.0, 5333.0, 5518.0, 5377.0, 5466.0, 5514.0, 5643.0, 5369.0, 5260.0, 5450.0, 5283.0, 5671.0, 5570.0, 5354.0, 5507.0, 5534.0, 5315.0, 5392.0, 5679.0, 5650.0, 5356.0, 5496.0, 5311.0, 5694.0, 5495.0, 5306.0, 5577.0, 5699.0, 5696.0, 5668.0, 5441.0, 5367.0, 5615.0, 5310.0, 5605.0, 5492.0, 5332.0, 5271.0 (number of hits: 8)
13	5270	9	1	333	1	5259.0, 5528.0, 5273.0, 5587.0, 5585.0, 5627.0, 5668.0, 5489.0, 5304.0, 5287.0, 5521.0, 5277.0, 5523.0, 5723.0, 5704.0, 5634.0, 5329.0, 5513.0, 5519.0, 5377.0, 5534.0, 5297.0, 5315.0, 5338.0, 5337.0, 5654.0, 5525.0, 5408.0, 5610.0, 5382.0, 5383.0, 5656.0, 5645.0, 5481.0, 5415.0, 5276.0, 5318.0, 5533.0, 5501.0, 5722.0, 5293.0, 5469.0, 5300.0, 5563.0, 5421.0, 5643.0, 5618.0, 5636.0, 5433.0, 5613.0, 5410.0, 5370.0, 5510.0, 5529.0, 5689.0, 5461.0, 5303.0, 5444.0, 5578.0, 5573.0, 5628.0, 5580.0, 5371.0, 5388.0, 5684.0, 5430.0, 5574.0, 5468.0, 5542.0, 5330.0, 5595.0, 5497.0, 5465.0, 5671.0, 5361.0, 5350.0, 5526.0, 5650.0, 5682.0, 5257.0, 5418.0, 5621.0, 5696.0, 5335.0, 5642.0, 5499.0, 5602.0, 5694.0, 5584.0, 5372.0, 5703.0, 5617.0, 5412.0, 5352.0, 5705.0, 5374.0, 5296.0, 5658.0, 5309.0, 5323.0 (number of hits: 6)
14	5270	9	1	333	1	5665.0, 5258.0, 5546.0, 5564.0, 5590.0, 5276.0, 5581.0, 5724.0, 5648.0, 5483.0, 5699.0, 5445.0, 5535.0, 5476.0, 5398.0, 5470.0, 5302.0, 5558.0, 5529.0, 5646.0, 5356.0, 5406.0, 5512.0, 5575.0, 5657.0, 5296.0, 5370.0, 5374.0, 5649.0, 5433.0, 5584.0, 5473.0, 5312.0, 5332.0, 5300.0, 5472.0, 5274.0, 5629.0, 5260.0, 5632.0, 5267.0, 5480.0, 5703.0, 5704.0, 5520.0, 5509.0, 5266.0, 5706.0, 5716.0, 5605.0, 5528.0, 5451.0, 5363.0, 5536.0, 5527.0, 5637.0, 5570.0, 5588.0, 5547.0, 5487.0, 5318.0, 5340.0, 5709.0, 5262.0, 5307.0, 5440.0, 5650.0, 5342.0, 5404.0, 5710.0, 5678.0, 5435.0, 5526.0, 5693.0, 5722.0, 5479.0, 5407.0, 5322.0, 5383.0, 5381.0, 5263.0, 5396.0, 5455.0, 5573.0, 5511.0, 5613.0, 5387.0, 5654.0, 5281.0, 5713.0, 5469.0, 5423.0, 5517.0, 5518.0, 5481.0, 5689.0, 5697.0, 5482.0, 5390.0, 5497.0 (number of hits: 9)
15	5270	9	1	333	1	5701.0, 5521.0, 5548.0, 5671.0, 5424.0, 5485.0, 5654.0, 5275.0, 5520.0, 5321.0, 5508.0, 5586.0, 5337.0, 5391.0, 5412.0, 5630.0, 5294.0, 5667.0, 5659.0, 5497.0,

						5482.0, 5289.0, 5609.0, 5434.0, 5309.0, 5644.0, 5553.0, 5679.0, 5265.0, 5650.0, 5706.0, 5379.0, 5381.0, 5546.0, 5355.0, 5419.0, 5359.0, 5695.0, 5581.0, 5529.0, 5495.0, 5356.0, 5280.0, 5369.0, 5328.0, 5610.0, 5333.0, 5348.0, 5460.0, 5677.0, 5710.0, 5722.0, 5559.0, 5563.0, 5483.0, 5702.0, 5592.0, 5312.0, 5302.0, 5587.0, 5450.0, 5295.0, 5398.0, 5567.0, 5561.0, 5432.0, 5344.0, 5400.0, 5433.0, 5422.0, 5290.0, 5392.0, 5500.0, 5277.0, 5459.0, 5375.0, 5335.0, 5718.0, 5651.0, 5279.0, 5489.0, 5620.0, 5315.0, 5388.0, 5490.0, 5427.0, 5604.0, 5550.0, 5704.0, 5478.0, 5652.0, 5600.0, 5318.0, 5643.0, 5394.0, 5504.0, 5269.0, 5404.0, 5316.0, 5635.0 (number of hits: 7)
16	5270	9	1	333	1	5278.0, 5469.0, 5603.0, 5367.0, 5454.0, 5277.0, 5668.0, 5472.0, 5563.0, 5285.0, 5705.0, 5633.0, 5598.0, 5529.0, 5561.0, 5445.0, 5315.0, 5437.0, 5425.0, 5449.0, 5413.0, 5709.0, 5373.0, 5322.0, 5579.0, 5625.0, 5307.0, 5693.0, 5510.0, 5686.0, 5710.0, 5661.0, 5593.0, 5332.0, 5708.0, 5677.0, 5723.0, 5418.0, 5455.0, 5366.0, 5443.0, 5276.0, 5343.0, 5299.0, 5364.0, 5341.0, 5556.0, 5698.0, 5286.0, 5648.0, 5432.0, 5599.0, 5715.0, 5370.0, 5501.0, 5567.0, 5320.0, 5340.0, 5374.0, 5601.0, 5252.0, 5527.0, 5251.0, 5565.0, 5526.0, 5571.0, 5617.0, 5540.0, 5706.0, 5355.0, 5460.0, 5507.0, 5267.0, 5344.0, 5266.0, 5649.0, 5596.0, 5421.0, 5664.0, 5478.0, 5271.0, 5586.0, 5484.0, 5407.0, 5365.0, 5415.0, 5614.0, 5619.0, 5359.0, 5290.0, 5539.0, 5427.0, 5336.0, 5666.0, 5489.0, 5536.0, 5476.0, 5646.0, 5509.0, 5584.0 (number of hits: 10)
17	5270	9	1	333	1	5344.0, 5307.0, 5454.0, 5449.0, 5341.0, 5328.0, 5468.0, 5410.0, 5325.0, 5497.0, 5413.0, 5318.0, 5372.0, 5490.0, 5722.0, 5562.0, 5354.0, 5509.0, 5336.0, 5434.0, 5262.0, 5556.0, 5668.0, 5594.0, 5398.0, 5390.0, 5512.0, 5287.0, 5618.0, 5526.0, 5452.0, 5679.0, 5715.0, 5537.0, 5494.0, 5544.0, 5522.0, 5702.0, 5323.0, 5437.0, 5476.0, 5317.0, 5442.0, 5689.0, 5620.0, 5275.0, 5256.0, 5296.0, 5368.0, 5415.0, 5531.0, 5649.0, 5376.0, 5400.0, 5581.0, 5403.0, 5720.0, 5532.0, 5673.0, 5570.0, 5553.0, 5574.0, 5624.0, 5635.0, 5505.0, 5306.0, 5713.0, 5557.0, 5591.0, 5406.0, 5701.0, 5457.0, 5626.0, 5351.0, 5254.0, 5298.0, 5609.0, 5334.0, 5477.0, 5358.0, 5339.0, 5564.0, 5373.0, 5547.0, 5342.0, 5615.0, 5697.0, 5267.0, 5389.0, 5365.0, 5534.0, 5332.0, 5266.0, 5527.0, 5664.0, 5253.0, 5273.0, 5686.0, 5380.0, 5560.0 (number of hits: 9)
18	5270	9	1	333	1	5427.0, 5685.0, 5370.0, 5666.0, 5389.0, 5358.0, 5278.0, 5365.0, 5521.0, 5698.0,

						5549.0, 5652.0, 5672.0, 5530.0, 5600.0, 5686.0, 5467.0, 5534.0, 5602.0, 5261.0, 5633.0, 5394.0, 5405.0, 5283.0, 5369.0, 5668.0, 5349.0, 5267.0, 5591.0, 5642.0, 5511.0, 5470.0, 5354.0, 5660.0, 5311.0, 5360.0, 5338.0, 5324.0, 5272.0, 5676.0, 5621.0, 5529.0, 5547.0, 5315.0, 5264.0, 5345.0, 5319.0, 5466.0, 5638.0, 5522.0, 5505.0, 5331.0, 5455.0, 5483.0, 5256.0, 5636.0, 5635.0, 5667.0, 5695.0, 5584.0, 5499.0, 5316.0, 5437.0, 5550.0, 5285.0, 5330.0, 5654.0, 5716.0, 5451.0, 5592.0, 5346.0, 5634.0, 5304.0, 5586.0, 5352.0, 5351.0, 5554.0, 5494.0, 5598.0, 5296.0, 5253.0, 5284.0, 5479.0, 5503.0, 5665.0, 5538.0, 5558.0, 5544.0, 5406.0, 5398.0, 5603.0, 5674.0, 5502.0, 5250.0, 5343.0, 5532.0, 5565.0, 5624.0, 5339.0, 5622.0 (number of hits: 11)
19	5270	9	1	333	1	5668.0, 5482.0, 5698.0, 5378.0, 5686.0, 5352.0, 5303.0, 5407.0, 5291.0, 5643.0, 5271.0, 5434.0, 5315.0, 5442.0, 5316.0, 5388.0, 5518.0, 5630.0, 5274.0, 5356.0, 5516.0, 5323.0, 5493.0, 5511.0, 5566.0, 5600.0, 5456.0, 5371.0, 5521.0, 5278.0, 5620.0, 5666.0, 5695.0, 5720.0, 5527.0, 5276.0, 5616.0, 5633.0, 5284.0, 5714.0, 5711.0, 5374.0, 5354.0, 5681.0, 5509.0, 5415.0, 5528.0, 5591.0, 5710.0, 5269.0, 5350.0, 5687.0, 5404.0, 5580.0, 5296.0, 5420.0, 5709.0, 5264.0, 5526.0, 5721.0, 5438.0, 5635.0, 5586.0, 5441.0, 5317.0, 5479.0, 5574.0, 5390.0, 5432.0, 5638.0, 5364.0, 5568.0, 5546.0, 5382.0, 5286.0, 5301.0, 5589.0, 5495.0, 5314.0, 5344.0, 5665.0, 5467.0, 5256.0, 5491.0, 5285.0, 5536.0, 5619.0, 5351.0, 5712.0, 5499.0, 5360.0, 5515.0, 5376.0, 5331.0, 5494.0, 5267.0, 5605.0, 5664.0, 5522.0, 5538.0 (number of hits: 11)
20	5270	9	1	333	1	5609.0, 5591.0, 5607.0, 5581.0, 5301.0, 5459.0, 5326.0, 5506.0, 5425.0, 5614.0, 5436.0, 5421.0, 5575.0, 5366.0, 5275.0, 5536.0, 5397.0, 5403.0, 5568.0, 5606.0, 5358.0, 5617.0, 5340.0, 5632.0, 5495.0, 5460.0, 5451.0, 5499.0, 5694.0, 5454.0, 5716.0, 5708.0, 5677.0, 5676.0, 5475.0, 5511.0, 5688.0, 5467.0, 5541.0, 5388.0, 5493.0, 5300.0, 5537.0, 5643.0, 5464.0, 5634.0, 5646.0, 5341.0, 5435.0, 5452.0, 5522.0, 5482.0, 5510.0, 5608.0, 5276.0, 5381.0, 5474.0, 5636.0, 5687.0, 5678.0, 5334.0, 5674.0, 5374.0, 5528.0, 5652.0, 5689.0, 5601.0, 5387.0, 5424.0, 5262.0, 5446.0, 5324.0, 5463.0, 5552.0, 5502.0, 5331.0, 5721.0, 5250.0, 5526.0, 5335.0, 5449.0, 5644.0, 5704.0, 5450.0, 5558.0, 5458.0, 5699.0, 5304.0, 5375.0, 5426.0, 5307.0, 5338.0, 5478.0, 5565.0, 5263.0, 5357.0, 5281.0, 5311.0, 5583.0, 5657.0 (number of hits: 6)

21	5290	9	1	333	1 5698.0, 5514.0, 5371.0, 5519.0, 5647.0, 5677.0, 5657.0, 5676.0, 5578.0, 5550.0, 5535.0, 5612.0, 5333.0, 5368.0, 5558.0, 5530.0, 5714.0, 5603.0, 5513.0, 5420.0, 5265.0, 5582.0, 5483.0, 5553.0, 5473.0, 5327.0, 5512.0, 5539.0, 5516.0, 5555.0, 5507.0, 5617.0, 5522.0, 5397.0, 5649.0, 5554.0, 5275.0, 5454.0, 5573.0, 5391.0, 5310.0, 5653.0, 5547.0, 5264.0, 5487.0, 5399.0, 5490.0, 5500.0, 5314.0, 5373.0, 5679.0, 5541.0, 5449.0, 5525.0, 5624.0, 5360.0, 5322.0, 5466.0, 5625.0, 5594.0, 5654.0, 5662.0, 5515.0, 5627.0, 5696.0, 5620.0, 5262.0, 5673.0, 5495.0, 5639.0, 5434.0, 5440.0, 5641.0, 5259.0, 5389.0, 5386.0, 5443.0, 5433.0, 5309.0, 5288.0, 5710.0, 5447.0, 5409.0, 5610.0, 5543.0, 5497.0, 5256.0, 5646.0, 5489.0, 5638.0, 5351.0, 5367.0, 5556.0, 5557.0, 5461.0, 5569.0, 5280.0, 5335.0, 5334.0, 5481.0 (number of hits: 4)
22	5290	9	1	333	1 5431.0, 5257.0, 5579.0, 5371.0, 5291.0, 5450.0, 5328.0, 5441.0, 5592.0, 5341.0, 5568.0, 5454.0, 5408.0, 5379.0, 5530.0, 5302.0, 5261.0, 5629.0, 5698.0, 5303.0, 5283.0, 5641.0, 5331.0, 5361.0, 5320.0, 5674.0, 5399.0, 5522.0, 5401.0, 5508.0, 5495.0, 5437.0, 5561.0, 5521.0, 5355.0, 5498.0, 5539.0, 5671.0, 5566.0, 5262.0, 5493.0, 5395.0, 5506.0, 5683.0, 5384.0, 5622.0, 5544.0, 5583.0, 5380.0, 5667.0, 5338.0, 5453.0, 5546.0, 5284.0, 5577.0, 5630.0, 5414.0, 5692.0, 5536.0, 5673.0, 5567.0, 5422.0, 5378.0, 5564.0, 5393.0, 5252.0, 5556.0, 5487.0, 5514.0, 5323.0, 5499.0, 5306.0, 5655.0, 5347.0, 5543.0, 5411.0, 5604.0, 5519.0, 5340.0, 5669.0, 5278.0, 5551.0, 5492.0, 5312.0, 5520.0, 5394.0, 5481.0, 5588.0, 5662.0, 5354.0, 5455.0, 5372.0, 5482.0, 5421.0, 5402.0, 5525.0, 5562.0, 5648.0, 5569.0, 5356.0 (number of hits: 7)
23	5290	9	1	333	1 5387.0, 5542.0, 5577.0, 5439.0, 5363.0, 5592.0, 5532.0, 5339.0, 5332.0, 5603.0, 5588.0, 5349.0, 5711.0, 5314.0, 5461.0, 5298.0, 5471.0, 5407.0, 5634.0, 5698.0, 5680.0, 5504.0, 5424.0, 5453.0, 5551.0, 5684.0, 5688.0, 5693.0, 5534.0, 5449.0, 5499.0, 5259.0, 5280.0, 5289.0, 5263.0, 5261.0, 5257.0, 5322.0, 5713.0, 5629.0, 5692.0, 5706.0, 5354.0, 5457.0, 5553.0, 5455.0, 5296.0, 5649.0, 5608.0, 5557.0, 5517.0, 5452.0, 5677.0, 5462.0, 5251.0, 5367.0, 5341.0, 5606.0, 5285.0, 5625.0, 5546.0, 5436.0, 5401.0, 5683.0, 5616.0, 5371.0, 5366.0, 5336.0, 5651.0, 5479.0, 5252.0, 5712.0, 5515.0, 5290.0, 5700.0, 5516.0, 5388.0, 5676.0, 5403.0, 5352.0, 5689.0, 5486.0, 5652.0, 5549.0, 5308.0, 5398.0, 5630.0, 5600.0, 5313.0, 5618.0, 5262.0, 5304.0, 5375.0, 5566.0, 5464.0,

						5519.0, 5545.0, 5642.0, 5390.0, 5343.0 (number of hits: 8)
24	5290	9	1	333	1	5390.0, 5324.0, 5509.0, 5466.0, 5641.0, 5373.0, 5548.0, 5437.0, 5404.0, 5676.0, 5395.0, 5597.0, 5449.0, 5644.0, 5627.0, 5334.0, 5634.0, 5400.0, 5377.0, 5286.0, 5305.0, 5479.0, 5491.0, 5415.0, 5618.0, 5434.0, 5547.0, 5410.0, 5596.0, 5432.0, 5512.0, 5472.0, 5606.0, 5310.0, 5563.0, 5530.0, 5632.0, 5686.0, 5516.0, 5442.0, 5301.0, 5418.0, 5444.0, 5672.0, 5610.0, 5378.0, 5306.0, 5608.0, 5684.0, 5478.0, 5458.0, 5303.0, 5716.0, 5482.0, 5545.0, 5555.0, 5664.0, 5710.0, 5344.0, 5700.0, 5486.0, 5469.0, 5372.0, 5342.0, 5707.0, 5507.0, 5583.0, 5544.0, 5431.0, 5679.0, 5518.0, 5279.0, 5480.0, 5623.0, 5687.0, 5253.0, 5609.0, 5721.0, 5590.0, 5697.0, 5468.0, 5339.0, 5361.0, 5593.0, 5693.0, 5677.0, 5453.0, 5671.0, 5322.0, 5723.0, 5341.0, 5706.0, 5309.0, 5251.0, 5375.0, 5592.0, 5459.0, 5358.0, 5502.0, 5631.0 (number of hits: 7)
25	5290	9	1	333	1	5561.0, 5575.0, 5719.0, 5554.0, 5306.0, 5587.0, 5337.0, 5574.0, 5488.0, 5461.0, 5593.0, 5407.0, 5387.0, 5566.0, 5715.0, 5614.0, 5330.0, 5640.0, 5571.0, 5395.0, 5702.0, 5622.0, 5326.0, 5652.0, 5482.0, 5348.0, 5547.0, 5661.0, 5521.0, 5260.0, 5658.0, 5378.0, 5356.0, 5532.0, 5689.0, 5335.0, 5721.0, 5406.0, 5537.0, 5651.0, 5549.0, 5280.0, 5452.0, 5390.0, 5685.0, 5501.0, 5261.0, 5660.0, 5360.0, 5530.0, 5504.0, 5414.0, 5271.0, 5588.0, 5298.0, 5471.0, 5419.0, 5676.0, 5538.0, 5610.0, 5611.0, 5379.0, 5514.0, 5513.0, 5275.0, 5374.0, 5403.0, 5557.0, 5346.0, 5259.0, 5603.0, 5667.0, 5420.0, 5424.0, 5262.0, 5473.0, 5369.0, 5503.0, 5391.0, 5470.0, 5633.0, 5615.0, 5641.0, 5706.0, 5568.0, 5444.0, 5382.0, 5389.0, 5656.0, 5638.0, 5400.0, 5717.0, 5632.0, 5316.0, 5597.0, 5319.0, 5367.0, 5724.0, 5312.0, 5709.0 (number of hits: 5)
26	5290	9	1	333	1	5540.0, 5251.0, 5582.0, 5535.0, 5280.0, 5503.0, 5273.0, 5277.0, 5349.0, 5634.0, 5584.0, 5647.0, 5459.0, 5689.0, 5308.0, 5515.0, 5315.0, 5387.0, 5406.0, 5323.0, 5458.0, 5666.0, 5305.0, 5609.0, 5372.0, 5285.0, 5403.0, 5366.0, 5440.0, 5371.0, 5348.0, 5580.0, 5402.0, 5599.0, 5282.0, 5682.0, 5517.0, 5417.0, 5345.0, 5619.0, 5338.0, 5671.0, 5391.0, 5590.0, 5546.0, 5692.0, 5312.0, 5485.0, 5642.0, 5392.0, 5600.0, 5493.0, 5504.0, 5717.0, 5432.0, 5444.0, 5413.0, 5495.0, 5497.0, 5437.0, 5513.0, 5250.0, 5705.0, 5610.0, 5616.0, 5390.0, 5719.0, 5304.0, 5608.0, 5662.0, 5643.0, 5534.0, 5347.0, 5629.0, 5591.0, 5351.0, 5471.0, 5295.0, 5516.0, 5640.0, 5341.0, 5680.0, 5449.0, 5438.0, 5314.0,

						5569.0, 5696.0, 5270.0, 5679.0, 5708.0, 5500.0, 5375.0, 5473.0, 5385.0, 5411.0, 5561.0, 5334.0, 5618.0, 5377.0, 5336.0 (number of hits: 10)
27	5290	9	1	333	1	5374.0, 5291.0, 5581.0, 5450.0, 5523.0, 5294.0, 5346.0, 5425.0, 5452.0, 5491.0, 5479.0, 5259.0, 5688.0, 5268.0, 5302.0, 5649.0, 5566.0, 5603.0, 5477.0, 5624.0, 5438.0, 5529.0, 5682.0, 5288.0, 5469.0, 5698.0, 5396.0, 5287.0, 5406.0, 5617.0, 5645.0, 5448.0, 5661.0, 5683.0, 5334.0, 5648.0, 5328.0, 5579.0, 5614.0, 5440.0, 5292.0, 5314.0, 5685.0, 5686.0, 5351.0, 5316.0, 5702.0, 5697.0, 5300.0, 5699.0, 5549.0, 5362.0, 5393.0, 5350.0, 5643.0, 5559.0, 5338.0, 5474.0, 5266.0, 5433.0, 5689.0, 5687.0, 5260.0, 5673.0, 5610.0, 5377.0, 5293.0, 5656.0, 5713.0, 5483.0, 5514.0, 5633.0, 5692.0, 5404.0, 5323.0, 5289.0, 5660.0, 5412.0, 5703.0, 5716.0, 5388.0, 5533.0, 5339.0, 5383.0, 5717.0, 5644.0, 5503.0, 5335.0, 5639.0, 5638.0, 5642.0, 5341.0, 5535.0, 5449.0, 5402.0, 5413.0, 5545.0, 5421.0, 5488.0, 5490.0 (number of hits: 9)
28	5290	9	1	333	1	5627.0, 5527.0, 5276.0, 5347.0, 5560.0, 5411.0, 5633.0, 5416.0, 5523.0, 5597.0, 5639.0, 5305.0, 5291.0, 5670.0, 5605.0, 5471.0, 5294.0, 5563.0, 5295.0, 5477.0, 5434.0, 5389.0, 5441.0, 5644.0, 5653.0, 5595.0, 5626.0, 5273.0, 5384.0, 5533.0, 5655.0, 5254.0, 5722.0, 5629.0, 5342.0, 5378.0, 5413.0, 5646.0, 5645.0, 5252.0, 5333.0, 5332.0, 5373.0, 5318.0, 5705.0, 5593.0, 5260.0, 5402.0, 5664.0, 5678.0, 5505.0, 5470.0, 5494.0, 5312.0, 5325.0, 5415.0, 5442.0, 5433.0, 5582.0, 5368.0, 5473.0, 5355.0, 5467.0, 5322.0, 5308.0, 5550.0, 5418.0, 5603.0, 5367.0, 5293.0, 5474.0, 5270.0, 5504.0, 5269.0, 5592.0, 5357.0, 5710.0, 5412.0, 5456.0, 5565.0, 5690.0, 5531.0, 5307.0, 5584.0, 5461.0, 5409.0, 5552.0, 5602.0, 5546.0, 5457.0, 5718.0, 5658.0, 5630.0, 5578.0, 5640.0, 5313.0, 5586.0, 5363.0, 5365.0, 5287.0 (number of hits: 11)
29	5290	9	1	333	1	5333.0, 5329.0, 5713.0, 5545.0, 5541.0, 5623.0, 5618.0, 5406.0, 5383.0, 5301.0, 5573.0, 5370.0, 5450.0, 5345.0, 5390.0, 5546.0, 5510.0, 5372.0, 5392.0, 5601.0, 5371.0, 5656.0, 5434.0, 5422.0, 5575.0, 5529.0, 5299.0, 5281.0, 5685.0, 5653.0, 5658.0, 5549.0, 5664.0, 5360.0, 5294.0, 5557.0, 5280.0, 5430.0, 5619.0, 5394.0, 5315.0, 5452.0, 5355.0, 5583.0, 5709.0, 5357.0, 5334.0, 5277.0, 5552.0, 5718.0, 5540.0, 5486.0, 5410.0, 5512.0, 5518.0, 5491.0, 5353.0, 5255.0, 5348.0, 5358.0, 5551.0, 5588.0, 5654.0, 5273.0, 5587.0, 5616.0, 5701.0, 5427.0, 5678.0, 5444.0, 5695.0, 5646.0, 5343.0, 5608.0, 5399.0,

						5256.0, 5323.0, 5283.0, 5279.0, 5420.0, 5723.0, 5435.0, 5611.0, 5703.0, 5714.0, 5503.0, 5598.0, 5655.0, 5313.0, 5702.0, 5570.0, 5291.0, 5251.0, 5487.0, 5648.0, 5495.0, 5571.0, 5706.0, 5316.0, 5593.0 (number of hits: 10)
30	5290	9	1	333	1	5477.0, 5581.0, 5449.0, 5634.0, 5436.0, 5674.0, 5693.0, 5323.0, 5348.0, 5528.0, 5322.0, 5562.0, 5639.0, 5370.0, 5334.0, 5289.0, 5362.0, 5432.0, 5293.0, 5298.0, 5471.0, 5288.0, 5468.0, 5645.0, 5662.0, 5352.0, 5502.0, 5643.0, 5369.0, 5413.0, 5673.0, 5364.0, 5547.0, 5418.0, 5691.0, 5302.0, 5272.0, 5536.0, 5628.0, 5563.0, 5524.0, 5577.0, 5380.0, 5254.0, 5573.0, 5610.0, 5274.0, 5472.0, 5345.0, 5452.0, 5392.0, 5612.0, 5285.0, 5251.0, 5476.0, 5465.0, 5257.0, 5615.0, 5270.0, 5586.0, 5376.0, 5590.0, 5286.0, 5606.0, 5637.0, 5467.0, 5679.0, 5281.0, 5658.0, 5558.0, 5567.0, 5480.0, 5711.0, 5556.0, 5698.0, 5629.0, 5478.0, 5530.0, 5481.0, 5493.0, 5587.0, 5678.0, 5341.0, 5320.0, 5291.0, 5346.0, 5574.0, 5414.0, 5397.0, 5313.0, 5488.0, 5464.0, 5578.0, 5256.0, 5595.0, 5417.0, 5383.0, 5368.0, 5444.0, 5647.0 (number of hits: 12)

A.3

80 MHz Bandwidth @ 5290 MHz

Table-1A/1B Radar Type 1A/1B Statistical Performance

Trial #	Fc (MHz)	Pulse/Burst	Pulse Width (µS)	PRI (µs)	Detection (1:yes; 0:no)
1	5251	65	1	818	1
2	5251	86	1	618	1
3	5251	95	1	558	1
4	5251	68	1	778	1
5	5251	67	1	798	1
6	5290	58	1	918	1
7	5290	78	1	678	1
8	5290	59	1	898	1
9	5290	61	1	878	1
10	5290	76	1	698	1
11	5329	57	1	938	1
12	5329	92	1	578	1
13	5329	18	1	3066	1
14	5329	89	1	598	1
15	5290	62	1	858	1
16	5251	38	1	1413	1
17	5251	19	1	2792	1
18	5251	24	1	2252	1
19	5251	30	1	1767	1
20	5251	40	1	1340	1
21	5290	29	1	1876	1
22	5290	39	1	1381	1
23	5290	21	1	2570	1
24	5290	46	1	1172	1
25	5290	31	1	1740	1
26	5329	39	1	1376	1
27	5329	20	1	2666	1
28	5329	19	1	2785	0
29	5329	21	1	2593	1
30	5290	18	1	3015	1
Detection Percentage: 96.67 % (>60%)					

Table-2 Radar Type 2 Statistical Performance

Trial #	Fc (MHz)	Pulse/Burst	Pulse Width (μS)	PRI (μs)	Detection (1:yes; 0:no)
1	5251	24	3.5	195	1
2	5251	24	1	223	1
3	5251	26	2.4	167	1
4	5251	29	3.4	215	1
5	5251	24	2.6	155	1
6	5251	26	1.3	170	1
7	5251	23	4.3	197	1
8	5251	26	3.8	227	1
9	5251	26	2.4	175	1
10	5251	29	3	163	1
11	5290	23	4.6	193	1
12	5290	25	1.9	225	1
13	5290	28	3.7	197	1
14	5290	28	2.7	176	1
15	5290	29	4	220	1
16	5290	26	1.7	150	1
17	5290	24	1.1	200	1
18	5290	26	4.6	197	1
19	5290	28	3.5	194	1
20	5290	24	4.9	222	1
21	5329	27	1.7	199	1
22	5329	28	4.6	220	1
23	5329	25	3.1	155	1
24	5329	29	4.3	163	0
25	5329	23	2.6	206	1
26	5329	28	4.5	221	1
27	5329	27	2.5	189	1
28	5329	24	1.3	223	1
29	5329	23	3.3	181	0
30	5329	27	4.3	226	0
Detection Percentage: 90 % (>60%)					

Table-3 Radar Type 3 Statistical Performance

Trial #	Fc (MHz)	Pulse/Burst	Pulse Width (μS)	PRI (μs)	Detection (1:yes; 0:no)
1	5251	16	8.7	336	1
2	5251	16	6.7	402	1
3	5251	16	7.8	260	1
4	5251	16	7.3	285	1
5	5251	16	9.7	226	1
6	5251	17	6.5	492	1
7	5251	17	6.8	250	1
8	5251	17	6.8	359	1
9	5251	18	9.8	258	1
10	5251	16	9.9	390	0
11	5290	16	7.6	416	1
12	5290	18	7	394	1
13	5290	17	9.2	433	1
14	5290	18	7	239	1
15	5290	17	9	237	1
16	5290	16	7.7	286	1
17	5290	18	9.4	444	1
18	5290	17	9.1	228	1
19	5290	17	7.5	266	1
20	5290	18	9.4	383	1
21	5329	18	9	461	1
22	5329	18	7.5	490	1
23	5329	18	9.2	434	1
24	5329	18	9.1	464	1
25	5329	16	6.7	495	1
26	5329	17	9.3	283	1
27	5329	17	9.4	486	1
28	5329	16	10	404	1
29	5329	18	7.1	357	1
30	5329	16	8.5	254	1
Detection Percentage: 96.67 % (>60%)					

Table-4 Radar Type 4 Statistical Performance

Trial #	Fc (MHz)	Pulse/Burst	Pulse Width (μS)	PRI (μs)	Detection (1:yes; 0:no)
1	5251	12	11	205	1
2	5251	12	17.9	219	1
3	5251	16	11.2	475	1
4	5251	15	16	224	1
5	5251	15	13.6	368	1
6	5251	16	13.1	325	1
7	5251	15	17	233	1
8	5251	16	19.7	409	1
9	5251	14	15.1	453	1
10	5251	13	13.1	251	1
11	5290	14	14.2	302	1
12	5290	16	12.4	317	1
13	5290	15	15.5	318	1
14	5290	12	17	287	1
15	5290	12	16.8	375	1
16	5290	12	16.4	241	1
17	5290	15	13.8	391	1
18	5290	16	16.3	495	1
19	5290	16	11.6	413	1
20	5290	13	15.9	417	1
21	5329	16	11.4	374	1
22	5329	13	17.5	239	1
23	5329	14	16.9	374	0
24	5329	15	11	482	1
25	5329	14	12.3	398	1
26	5329	14	18.7	285	1
27	5329	15	16.5	329	1
28	5329	16	15.2	292	1
29	5329	14	11.6	449	1
30	5329	13	18.8	368	1
Detection Percentage: 96.67 % (>60%)					

Table-5 Radar Type 5 Statistical Performance

Trial #	Fc (MHz)	Detection (1:yes; 0:no)
1	5290.0	1
2	5290.0	1
3	5290.0	1
4	5290.0	1
5	5290.0	1
6	5290.0	1
7	5290.0	1
8	5290.0	1
9	5290.0	1
10	5290.0	1
11	5253.4	1
12	5258.6	0
13	5256.6	1
14	5254.2	1
15	5255.0	1
16	5257.4	1
17	5256.2	0
18	5258.6	0
19	5256.6	1
20	5256.2	1
21	5326.2	1
22	5324.2	1
23	5326.2	1
24	5326.2	1
25	5326.2	1
26	5326.2	1
27	5321.8	1
28	5321.4	1
29	5325.0	1
30	5323.0	1
Detection Percentage: 90 % (>80%)		

Bin5 Statistics 1

Trial #	Pulse	Chirp (MHz)	Pulse Width (µS)	Pulse 1-2 spacing (µS)	Pulse 2-3 spacing (µS)	Pulse Start(S)	Detection (1:yes; 0:no)
0	3	11	67.1	1641	1217	0.733433	1
1	2	11	87.9	1399		1.451565	
2	2	11	73.5	1951		2.36831	
3	1	11	75			3.155464	
4	1	11	66.9			4.66584	
5	1	11	59.6			5.028811	
6	2	11	82.9	1659		6.157751	
7	1	11	63.1			7.784767	
8	2	11	68.3	1168		8.981671	
9	2	11	87.7	1544		9.552462	
10	3	11	71.3	1652	1077	10.119033	
11	3	11	71.1	1728	1788	11.475838	

Bin5 Statistics 2

Trial #	Pulse	Chirp (MHz)	Pulse Width (µS)	Pulse 1-2 spacing (µS)	Pulse 2-3 spacing (µS)	Pulse Start(S)	Detection (1:yes; 0:no)
0	2	6	98.4	1825		1.295464	1
1	2	6	77.7	1676		2.134692	
2	2	6	86.8	1447		4.086359	
3	3	6	54	1291	1255	5.08001	
4	3	6	56	1871	1303	6.794101	
5	2	6	61.7	1971		8.665206	
6	3	6	87.8	1692	1308	10.182373	
7	1	6	86.5			11.086024	

Bin5 Statistics 3

Trial #	Pulse	Chirp (MHz)	Pulse Width (µS)	Pulse 1-2 spacing (uS)	Pulse 2-3 spacing (uS)	Pulse Start(S)	Detection (1:yes; 0:no)
0	2	16	74.5	1947		0.665709	1
1	2	16	88.6	1657		1.856735	
2	3	16	74	1622	1097	2.197765	
3	3	16	78.4	1664	1063	3.0085	
4	3	16	98.7	1666	1819	4.51079	
5	2	16	79.2	1593		5.250163	
6	3	16	92.4	1408	1283	6.063601	
7	2	16	58.6	1002		7.165078	
8	2	16	72.8	1599		8.008508	
9	2	16	69.5	1507		9.030702	
10	1	16	60.8			10.298794	
11	3	16	67.5	1088	1477	11.486127	

Bin5 Statistics 4

Trial #	Pulse	Chirp (MHz)	Pulse Width (µS)	Pulse 1-2 spacing (uS)	Pulse 2-3 spacing (uS)	Pulse Start(S)	Detection (1:yes; 0:no)
0	2	8	57.7	1282		0.47354	1
1	2	8	72.8	1009		0.946385	
2	3	8	70.3	1628	1410	1.376226	
3	2	8	84.2	1705		2.254838	
4	2	8	89.3	1030		2.589018	
5	3	8	97.5	1150	1257	3.279683	
6	1	8	80.9			3.70127	
7	2	8	79.8	1798		4.778596	
8	2	8	90.6	1428		5.315188	
9	1	8	90.7			5.418245	
10	3	8	52.4	1003	1866	6.249844	
11	2	8	79.3	1999		7.016075	
12	1	8	85.2			7.686208	
13	2	8	72.2	1507		8.005104	
14	2	8	80.2	1387		8.74112	
15	1	8	82.1			9.223326	
16	2	8	50.7	1969		9.903524	
17	3	8	83.9	1832	1233	10.479311	
18	2	8	91.4	1356		10.914513	
19	1	8	57.3			11.570622	

Bin5 Statistics 5

Trial #	Pulse	Chirp (MHz)	Pulse Width (µS)	Pulse 1-2 spacing (uS)	Pulse 2-3 spacing (uS)	Pulse Start(S)	Detection (1:yes; 0:no)
0	1	9	69.4			0.47819	1
1	3	9	91.4	1970	1830	1.230214	
2	3	9	56.6	1597	1267	1.735597	
3	3	9	87.4	1175	1191	2.627878	
4	2	9	52.5	1652		3.032393	
5	3	9	73.8	1246	1276	3.456919	
6	3	9	78	1812	1693	4.201193	
7	2	9	91.4	1790		5.204903	
8	2	9	85.6	1560		5.734273	
9	2	9	69.8	1989		6.361472	
10	2	9	54.1	1063		6.828759	
11	3	9	59.5	1724	1785	7.733024	
12	2	9	57.9	1673		8.541693	
13	2	9	51	1961		8.901354	
14	2	9	73.9	1577		9.431452	
15	2	9	74.4	1326		10.063788	
16	2	9	62	1113		11.308129	
17	2	9	50.4	1251		11.732939	

Bin5 Statistics 6

Trial #	Pulse	Chirp (MHz)	Pulse Width (µS)	Pulse 1-2 spacing (uS)	Pulse 2-3 spacing (uS)	Pulse Start(S)	Detection (1:yes; 0:no)
0	1	8	51			0.388071	1
1	1	8	74.5			1.332946	
2	1	8	56.5			1.756082	
3	2	8	62.1	1807		2.294384	
4	2	8	67.7	1446		3.059148	
5	2	8	75.4	1878		3.897171	
6	2	8	69.2	1821		5.016895	
7	2	8	82.2	1772		5.753138	
8	1	8	70.7			6.492991	
9	1	8	74.3			7.327792	
10	2	8	86.2	1589		8.244635	
11	1	8	87.7			8.92213	
12	1	8	83.3			9.16834	
13	2	8	57.4	1182		9.925419	
14	2	8	80.8	1437		10.907992	
15	2	8	61.4	1335		11.901886	

Bin5 Statistics 7

Trial #	Pulse	Chirp (MHz)	Pulse Width (µS)	Pulse 1-2 spacing (uS)	Pulse 2-3 spacing (uS)	Pulse Start(S)	Detection (1:yes; 0:no)
0	2	15	79.1	1683		0.248555	1
1	2	15	75.4	1205		2.101334	
2	2	15	84	1219		3.094555	
3	2	15	82.6	1779		4.634704	
4	1	15	84.4			5.574756	
5	2	15	95.7	1674		6.888214	
6	3	15	53	1826	1774	8.595785	
7	3	15	99.2	1474	1993	9.67232	
8	1	15	60.8			11.721725	

Bin5 Statistics 8

Trial #	Pulse	Chirp (MHz)	Pulse Width (µS)	Pulse 1-2 spacing (uS)	Pulse 2-3 spacing (uS)	Pulse Start(S)	Detection (1:yes; 0:no)
0	3	8	70.7	1854	1467	0.159203	1
1	3	8	75.9	1136	1956	1.34118	
2	2	8	77.1	1913		1.976432	
3	3	8	75.8	1251	1150	2.329035	
4	2	8	82.1	1615		3.339071	
5	1	8	64.5			3.721854	
6	1	8	73.4			4.536875	
7	2	8	91.7	1539		5.575906	
8	2	8	81.7	1433		5.692457	
9	1	8	57.8			6.983122	
10	3	8	72.2	1781	1376	7.479793	
11	3	8	85.7	1393	1773	7.844897	
12	1	8	51.5			8.518759	
13	1	8	74.6			9.457738	
14	1	8	79.2			10.174822	
15	2	8	89.8	1693		10.975725	
16	1	8	72.7			11.710247	

Bin5 Statistics 9

Trial #	Pulse	Chirp (MHz)	Pulse Width (µS)	Pulse 1-2 spacing (uS)	Pulse 2-3 spacing (uS)	Pulse Start(S)	Detection (1:yes; 0:no)
0	2	13	64.2	1744		0.607943	1
1	1	13	62.3			1.464726	
2	3	13	55.2	1461	1167	2.406952	
3	2	13	58.3	1652		3.63985	
4	2	13	59.3	1402		4.661574	
5	2	13	67.7	1630		5.875098	
6	3	13	58.3	1040	1962	6.011793	
7	1	13	55.7			7.543048	
8	3	13	81.1	1332	1399	8.746756	
9	2	13	95.3	1047		9.469181	
10	2	13	94	1200		10.562463	
11	2	13	68.2	1005		11.26557	

Bin5 Statistics 10

Trial #	Pulse	Chirp (MHz)	Pulse Width (µS)	Pulse 1-2 spacing (uS)	Pulse 2-3 spacing (uS)	Pulse Start(S)	Detection (1:yes; 0:no)
0	2	9	84	1432		0.537348	1
1	3	9	87.1	1877	1234	2.793682	
2	2	9	91.5	1020		3.142178	
3	3	9	76.5	1594	1991	4.624511	
4	1	9	82			7.456766	
5	1	9	69.1			8.171119	
6	2	9	85.3	1419		9.608916	
7	1	9	81.8			10.995385	

Bin5 Statistics 11

Trial #	Pulse	Chirp (MHz)	Pulse Width (µS)	Pulse 1-2 spacing (µS)	Pulse 2-3 spacing (µS)	Pulse Start(S)	Detection (1:yes; 0:no)
0	2	6	91.3	1546		0.683231	1
1	2	6	60.9	1064		1.404097	
2	2	6	55	1050		2.36231	
3	2	6	74.9	1429		2.96801	
4	2	6	89	1107		3.777144	
5	2	6	96	1191		4.05537	
6	2	6	86.6	1711		4.883975	
7	3	6	89.2	1905	1505	6.0962	
8	2	6	70.3	1735		7.187694	
9	2	6	62	1788		7.489486	
10	1	6	87.9			8.456912	
11	1	6	57.6			9.417508	
12	1	6	63.4			9.902828	
13	2	6	79.4	1114		11.160988	
14	1	6	51.9			11.950383	

Bin5 Statistics 12

Trial #	Pulse	Chirp (MHz)	Pulse Width (µS)	Pulse 1-2 spacing (µS)	Pulse 2-3 spacing (µS)	Pulse Start(S)	Detection (1:yes; 0:no)
0	3	19	88.7	1788	1829	0.568977	0
1	1	19	82.8			1.472155	
2	3	19	68.6	1810	1659	2.153662	
3	2	19	65.4	1954		3.45334	
4	1	19	90.5			4.63063	
5	3	19	75.7	1538	1838	5.980654	
6	2	19	56.5	1514		6.627051	
7	2	19	72.7	1587		7.386704	
8	1	19	67.7			8.123524	
9	2	19	96.5	1181		9.315416	
10	1	19	92.7			10.711165	
11	3	19	83.8	1738	1849	11.23107	

Bin5 Statistics 13

Trial #	Pulse	Chirp (MHz)	Pulse Width (µS)	Pulse 1-2 spacing (µS)	Pulse 2-3 spacing (µS)	Pulse Start(S)	Detection (1:yes; 0:no)
0	2	14	79.9	1047		0.301602	1
1	3	14	84.1	1753	1905	1.279963	
2	2	14	87.1	1961		2.815387	
3	3	14	72.2	1187	1468	3.319969	
4	1	14	56.1			4.493236	
5	3	14	93.6	1502	1187	5.909962	
6	1	14	99.9			7.325152	
7	1	14	62.4			8.151572	
8	2	14	94.1	1098		9.215748	
9	2	14	80.1	1581		10.791071	
10	2	14	96.6	1907		11.692289	

Bin5 Statistics 14

Trial #	Pulse	Chirp (MHz)	Pulse Width (µS)	Pulse 1-2 spacing (µS)	Pulse 2-3 spacing (µS)	Pulse Start(S)	Detection (1:yes; 0:no)
0	2	8	68.6	1835		0.679423	1
1	2	8	87.8	1705		0.966236	
2	3	8	78.4	1988	1617	1.66108	
3	1	8	64.6			2.65535	
4	1	8	53.8			3.22863	
5	1	8	55.5			4.44429	
6	2	8	93.5	1097		5.493262	
7	2	8	59.6	1434		6.046354	
8	1	8	93			6.777568	
9	3	8	64.9	1077	1247	7.284109	
10	2	8	77.5	1172		8.328167	
11	3	8	97.9	1043	1328	9.04936	
12	1	8	82.7			10.172228	
13	2	8	51.1	1020		10.524442	
14	1	8	89			11.976473	

Bin5 Statistics 15

Trial #	Pulse	Chirp (MHz)	Pulse Width (µS)	Pulse 1-2 spacing (uS)	Pulse 2-3 spacing (uS)	Pulse Start(S)	Detection (1:yes; 0:no)
0	1	10	84.5			0.077504	1
1	2	10	94.2	1303		1.472847	
2	2	10	97.6	1599		2.323916	
3	3	10	72.4	1881	1151	3.06011	
4	3	10	89.4	1561	1724	3.751374	
5	2	10	91.9	1302		4.652573	
6	2	10	90.8	1879		5.583709	
7	2	10	96.6	1727		5.616624	
8	3	10	98.8	1895	1178	6.517343	
9	3	10	97.8	1762	1599	7.475926	
10	1	10	93.9			8.208853	
11	2	10	60.4	1500		8.838934	
12	3	10	51.9	1549	1624	9.907385	
13	2	10	74.9	1181		10.516498	
14	3	10	75.5	1025	1687	11.505835	

Bin5 Statistics 16

Trial #	Pulse	Chirp (MHz)	Pulse Width (µS)	Pulse 1-2 spacing (uS)	Pulse 2-3 spacing (uS)	Pulse Start(S)	Detection (1:yes; 0:no)
0	2	16	68.5	1244		0.033641	1
1	1	16	84			0.697414	
2	3	16	79.2	1636	1458	1.51404	
3	1	16	65.5			1.951859	
4	2	16	80.5	1585		2.795527	
5	2	16	65.4	1496		3.539165	
6	3	16	57.8	1386	1242	3.607447	
7	1	16	86			4.362684	
8	2	16	81.6	1196		4.843303	
9	2	16	67.7	1965		5.631616	
10	2	16	51.5	1127		6.246192	
11	3	16	74.1	1402	1951	6.800535	
12	2	16	78.4	1439		7.423093	
13	2	16	55.5	1643		8.098201	
14	2	16	69.6	1661		8.522032	
15	2	16	70	1375		9.502637	
16	3	16	75.6	1049	1205	9.642873	
17	2	16	60.7	1528		10.747037	
18	2	16	94.4	1333		11.022953	
19	1	16	55.3			11.851092	

Bin5 Statistics 17

Trial #	Pulse	Chirp (MHz)	Pulse Width (µS)	Pulse 1-2 spacing (uS)	Pulse 2-3 spacing (uS)	Pulse Start(S)	Detection (1:yes; 0:no)
0	3	13	98.8	1520	1873	0.829579	0
1	1	13	89			2.000469	
2	2	13	56.1	1519		3.668861	
3	3	13	85.1	1633	1129	5.22062	
4	1	13	63.3			5.589098	
5	2	13	61.6	1540		7.721548	
6	1	13	91.7			8.03386	
7	2	13	52.8	1236		9.531291	
8	2	13	80.1	1544		11.533254	

Bin5 Statistics 18

Trial #	Pulse	Chirp (MHz)	Pulse Width (µS)	Pulse 1-2 spacing (uS)	Pulse 2-3 spacing (uS)	Pulse Start(S)	Detection (1:yes; 0:no)
0	3	19	65.4	1641	1213	0.268834	0
1	1	19	55.5			1.685721	
2	2	19	62.2	1742		2.743122	
3	3	19	62.5	1683	1575	3.561545	
4	2	19	78.9	1172		5.093165	
5	2	19	60.3	1772		6.260373	
6	3	19	75.3	1462	1120	6.801734	
7	2	19	71.8	1422		8.178362	
8	2	19	59.2	1827		9.027296	
9	2	19	87	1189		10.809309	
10	3	19	84.1	1632	1088	11.54768	

Bin5 Statistics 19

Trial #	Pulse	Chirp (MHz)	Pulse Width (µS)	Pulse 1-2 spacing (uS)	Pulse 2-3 spacing (uS)	Pulse Start(S)	Detection (1:yes; 0:no)
0	2	14	92.3	1871		0.434395	1
1	1	14	90			1.139473	
2	3	14	87	1976	1418	1.706193	
3	3	14	89	1942	1302	3.149222	
4	2	14	63	1691		3.834275	
5	3	14	83	1153	1282	4.648981	
6	2	14	91.2	1517		5.354387	
7	3	14	99.8	1448	1436	5.617828	
8	1	14	98.9			6.894199	
9	2	14	57	1706		7.418709	
10	2	14	79.2	1822		8.401388	
11	3	14	84.1	1804	1822	9.254952	
12	2	14	78	1163		10.33457	
13	1	14	61.6			11.056605	
14	2	14	67	1425		11.208956	

Bin5 Statistics 20

Trial #	Pulse	Chirp (MHz)	Pulse Width (µS)	Pulse 1-2 spacing (uS)	Pulse 2-3 spacing (uS)	Pulse Start(S)	Detection (1:yes; 0:no)
0	1	13	52.4			0.604697	1
1	1	13	80.7			1.771301	
2	1	13	89.1			2.287139	
3	3	13	68.2	1687	1749	3.710174	
4	2	13	88.8	1041		4.691236	
5	1	13	84.3			5.48719	
6	3	13	55.2	1028	1702	6.140446	
7	2	13	68.2	1419		7.49961	
8	3	13	66.1	1305	1699	8.090287	
9	2	13	81.4	1118		9.618282	
10	1	13	82.4			10.806532	
11	1	13	74.3			11.72557	

Bin5 Statistics 21

Trial #	Pulse	Chirp (MHz)	Pulse Width (µS)	Pulse 1-2 spacing (uS)	Pulse 2-3 spacing (uS)	Pulse Start(S)	Detection (1:yes; 0:no)
0	3	7	59.5	1012	1793	0.284184	1
1	2	7	58.9	1120		1.367055	
2	2	7	63.9	1607		2.255636	
3	2	7	55.7	1462		3.948829	
4	3	7	97	1038	1380	4.410937	
5	2	7	90.6	1737		5.871907	
6	2	7	72	1091		6.80785	
7	3	7	84.8	1663	1019	7.228462	
8	2	7	51.2	1270		8.426952	
9	1	7	79.7			9.423906	
10	2	7	65	1087		10.599821	
11	1	7	68.8			11.647303	

Bin5 Statistics 22

Trial #	Pulse	Chirp (MHz)	Pulse Width (µS)	Pulse 1-2 spacing (uS)	Pulse 2-3 spacing (uS)	Pulse Start(S)	Detection (1:yes; 0:no)
0	1	12	61.4			0.947385	1
1	2	12	69.7	1096		1.792579	
2	2	12	75.6	1307		2.784826	
3	2	12	69.7	1314		4.724616	
4	3	12	50.4	1373	1708	6.240715	
5	3	12	97.6	1554	1078	6.701311	
6	3	12	66.2	1421	1406	8.133155	
7	2	12	77.3	1455		10.476528	
8	2	12	56.5	1331		11.105683	

Bin5 Statistics 23

Trial #	Pulse	Chirp (MHz)	Pulse Width (µS)	Pulse 1-2 spacing (uS)	Pulse 2-3 spacing (uS)	Pulse Start(S)	Detection (1:yes; 0:no)
0	2	7	97.8	1398		0.013242	1
1	2	7	66.9	1866		2.109083	
2	2	7	55.1	1170		3.631054	
3	3	7	83.8	1581	1109	4.666196	
4	2	7	73.2	1670		6.43416	
5	2	7	98.4	1704		7.027221	
6	1	7	65			9.262082	
7	3	7	50.7	1370	1738	10.026316	
8	2	7	68.5	1126		11.870417	

Bin5 Statistics 24

Trial #	Pulse	Chirp (MHz)	Pulse Width (µS)	Pulse 1-2 spacing (uS)	Pulse 2-3 spacing (uS)	Pulse Start(S)	Detection (1:yes; 0:no)
0	1	7	99.1			1.069985	1
1	3	7	89.9	1959	1476	1.178142	
2	3	7	99.8	1797	1773	2.234846	
3	2	7	99.7	1505		3.980488	
4	1	7	83.4			5.326553	
5	2	7	87.4	1775		5.780855	
6	2	7	83.1	1848		7.61421	
7	2	7	72.6	1236		8.393439	
8	2	7	67.9	1177		8.974968	
9	2	7	94.6	1975		10.392023	
10	2	7	59.6	1276		11.372087	

Bin5 Statistics 25

Trial #	Pulse	Chirp (MHz)	Pulse Width (µS)	Pulse 1-2 spacing (uS)	Pulse 2-3 spacing (uS)	Pulse Start(S)	Detection (1:yes; 0:no)
0	1	7	93			0.268459	1
1	1	7	92.8			0.73586	
2	1	7	68.9			1.362148	
3	3	7	82.6	1057	1003	2.214961	
4	2	7	79.8	1785		2.922942	
5	1	7	79.9			3.430368	
6	1	7	94.3			4.65157	
7	2	7	62.6	1022		5.002206	
8	3	7	98	1874	1200	5.380688	
9	2	7	78.7	1019		6.3593	
10	1	7	86.5			6.840217	
11	1	7	73.1			7.797412	
12	2	7	63.3	1838		8.594745	
13	2	7	94.9	1554		8.675329	
14	2	7	94.4	1002		9.335742	
15	2	7	85	1635		10.395681	
16	2	7	99.2	1980		11.129234	
17	3	7	87.5	1683	1313	11.751979	

Bin5 Statistics 26

Trial #	Pulse	Chirp (MHz)	Pulse Width (µS)	Pulse 1-2 spacing (uS)	Pulse 2-3 spacing (uS)	Pulse Start(S)	Detection (1:yes; 0:no)
0	2	7	75.1	1361		0.388378	1
1	3	7	87.5	1638	1487	1.167166	
2	2	7	83.9	1883		2.126484	
3	2	7	81.1	1035		3.192583	
4	1	7	95.3			3.937705	
5	3	7	72.1	1552	1883	4.356455	
6	1	7	55.3			5.582664	
7	2	7	97.3	1084		6.241402	
8	1	7	88.4			7.535234	
9	2	7	95.1	1031		8.110967	
10	2	7	81.4	1428		9.167621	
11	2	7	71.2	1752		10.201577	
12	1	7	92.5			10.550051	
13	2	7	71.9	1750		11.802863	

Bin5 Statistics 27

Trial #	Pulse	Chirp (MHz)	Pulse Width (µS)	Pulse 1-2 spacing (uS)	Pulse 2-3 spacing (uS)	Pulse Start(S)	Detection (1:yes; 0:no)
0	1	18	85.3			0.065268	1
1	2	18	91.9	1949		2.064881	
2	3	18	69.9	1635	1460	3.073138	
3	3	18	79.8	1304	1381	4.396408	
4	3	18	92.4	1382	1350	5.586125	
5	1	18	78.8			6.099971	
6	2	18	56.2	1009		7.671082	
7	2	18	59.1	1933		9.228915	
8	1	18	87.6			10.564631	
9	2	18	52.3	1554		11.798673	

Bin5 Statistics 28

Trial #	Pulse	Chirp (MHz)	Pulse Width (µS)	Pulse 1-2 spacing (uS)	Pulse 2-3 spacing (uS)	Pulse Start(S)	Detection (1:yes; 0:no)
0	3	19	58.5	1313	1271	0.51033	1
1	2	19	95.8	1666		1.747094	
2	3	19	85.6	1241	1190	3.348954	
3	2	19	77.1	1690		4.395236	
4	1	19	93			5.821158	
5	2	19	64.2	1589		7.025117	
6	1	19	65			8.957924	
7	2	19	72.1	1560		9.540894	
8	2	19	74.9	1556		11.953053	

Bin5 Statistics 29

Trial #	Pulse	Chirp (MHz)	Pulse Width (µS)	Pulse 1-2 spacing (µS)	Pulse 2-3 spacing (µS)	Pulse Start(S)	Detection (1:yes; 0:no)
0	1	10	62.6			0.241713	1
1	2	10	57.8	1980		0.95763	
2	1	10	51.6			2.026463	
3	1	10	90.2			2.726853	
4	3	10	78.2	1842	1368	2.832416	
5	2	10	64.7	1174		4.003982	
6	3	10	90.5	1310	1524	4.456948	
7	3	10	78.4	1339	1667	5.549164	
8	2	10	51.7	1575		5.894407	
9	1	10	65.7			6.797892	
10	2	10	80.4	1788		7.451815	
11	3	10	97.9	1908	1253	7.821903	
12	1	10	74.5			9.101293	
13	2	10	82.6	1704		9.61252	
14	1	10	87.3			10.23344	
15	2	10	55.6	1809		10.61333	
16	3	10	77.2	1838	1750	11.965966	

Bin5 Statistics 30

Trial #	Pulse	Chirp (MHz)	Pulse Width (µS)	Pulse 1-2 spacing (µS)	Pulse 2-3 spacing (µS)	Pulse Start(S)	Detection (1:yes; 0:no)
0	1	15	51.2			0.773206	1
1	3	15	59.2	1119	1101	1.682099	
2	2	15	97.9	1172		1.738031	
3	2	15	57.2	1290		3.313572	
4	3	15	58.9	1203	1002	4.202878	
5	3	15	78.6	1712	1445	4.390999	
6	3	15	63.9	1771	1745	5.668234	
7	2	15	62	1490		6.350707	
8	1	15	81.1			7.104752	
9	3	15	65.9	1148	1412	7.79755	
10	2	15	63.8	1038		9.224953	
11	3	15	73.6	1486	1024	10.169296	
12	3	15	69.4	1727	1228	10.795297	
13	2	15	94.1	1600		11.191952	

Table-6 Radar Type 6 Statistical Performance

Trial #	Fc (MHz)	Pulse /Burst	Pulse Width (µS)	PRI (µs)	Detection (1:yes; 0:no)	Hopping Sequence
1	5250	9	1	333	0	
2	5251	9	1	333	1	5660.0, 5327.0, 5345.0, 5347.0, 5652.0, 5588.0, 5280.0, 5402.0, 5389.0, 5620.0, 5473.0, 5442.0, 5264.0, 5640.0, 5709.0, 5423.0, 5421.0, 5519.0, 5698.0, 5706.0, 5262.0, 5404.0, 5689.0, 5673.0, 5536.0, 5679.0, 5343.0, 5503.0, 5615.0, 5625.0, 5410.0, 5668.0, 5416.0, 5714.0, 5672.0, 5297.0, 5360.0, 5411.0, 5677.0, 5270.0, 5471.0, 5605.0, 5670.0, 5687.0, 5276.0, 5484.0, 5696.0, 5666.0, 5482.0, 5453.0, 5372.0, 5477.0, 5355.0, 5686.0, 5323.0, 5475.0, 5342.0, 5550.0, 5434.0, 5534.0, 5391.0, 5662.0, 5649.0, 5378.0, 5306.0, 5491.0, 5340.0, 5623.0, 5332.0, 5544.0, 5576.0, 5712.0, 5533.0, 5639.0, 5334.0, 5300.0, 5283.0, 5448.0, 5287.0, 5631.0, 5647.0, 5701.0, 5571.0, 5505.0, 5575.0, 5392.0, 5337.0, 5721.0, 5427.0, 5493.0, 5470.0, 5653.0, 5468.0, 5369.0, 5359.0, 5549.0, 5711.0, 5676.0, 5400.0, 5485.0 (number of hits: 7)
3	5251	9	1	333	1	5653.0, 5455.0, 5268.0, 5557.0, 5667.0, 5424.0, 5621.0, 5602.0, 5305.0, 5587.0, 5683.0, 5466.0, 5408.0, 5702.0, 5493.0, 5375.0, 5365.0, 5534.0, 5574.0, 5275.0, 5516.0, 5398.0, 5562.0, 5638.0, 5716.0, 5384.0, 5487.0, 5658.0, 5583.0, 5253.0, 5302.0, 5663.0, 5717.0, 5578.0, 5586.0, 5499.0, 5444.0, 5279.0, 5274.0, 5344.0, 5554.0, 5640.0, 5685.0, 5603.0, 5449.0, 5529.0, 5259.0, 5549.0, 5378.0, 5719.0, 5428.0, 5706.0, 5601.0, 5672.0, 5256.0, 5280.0, 5359.0, 5695.0, 5533.0, 5591.0, 5448.0, 5490.0, 5651.0, 5363.0, 5486.0, 5417.0, 5458.0, 5324.0, 5628.0, 5314.0, 5656.0, 5382.0, 5327.0, 5522.0, 5331.0, 5401.0, 5290.0, 5686.0, 5311.0, 5460.0, 5615.0, 5463.0, 5623.0, 5252.0, 5299.0, 5298.0, 5399.0, 5504.0, 5475.0, 5584.0, 5540.0, 5550.0, 5425.0, 5606.0, 5680.0, 5531.0, 5484.0, 5530.0, 5617.0, 5452.0 (number of hits: 9)
4	5251	9	1	333	1	5364.0, 5463.0, 5440.0, 5494.0, 5474.0, 5271.0, 5713.0, 5720.0, 5354.0, 5453.0, 5592.0, 5379.0, 5531.0, 5360.0, 5406.0, 5626.0, 5724.0, 5649.0, 5417.0, 5421.0, 5594.0, 5254.0, 5643.0, 5434.0, 5470.0, 5471.0, 5602.0, 5630.0, 5399.0, 5429.0, 5297.0, 5666.0, 5670.0, 5578.0, 5628.0, 5377.0, 5491.0, 5478.0, 5684.0, 5328.0, 5517.0, 5584.0, 5527.0, 5250.0, 5569.0, 5458.0, 5703.0, 5604.0, 5642.0, 5663.0, 5286.0, 5705.0, 5355.0, 5621.0, 5344.0, 5322.0, 5613.0, 5568.0, 5714.0, 5444.0, 5479.0, 5331.0, 5640.0, 5587.0, 5717.0,

						5546.0, 5384.0, 5512.0, 5648.0, 5422.0, 5430.0, 5445.0, 5719.0, 5462.0, 5553.0, 5590.0, 5304.0, 5539.0, 5571.0, 5378.0, 5252.0, 5317.0, 5534.0, 5264.0, 5255.0, 5652.0, 5394.0, 5688.0, 5459.0, 5678.0, 5680.0, 5486.0, 5389.0, 5312.0, 5439.0, 5274.0, 5616.0, 5305.0, 5588.0, 5521.0 (number of hits: 8)
5	5251	9	1	333	1	5529.0, 5678.0, 5578.0, 5285.0, 5633.0, 5381.0, 5278.0, 5507.0, 5644.0, 5396.0, 5643.0, 5358.0, 5660.0, 5714.0, 5307.0, 5277.0, 5288.0, 5661.0, 5708.0, 5367.0, 5594.0, 5647.0, 5690.0, 5640.0, 5679.0, 5389.0, 5388.0, 5638.0, 5479.0, 5357.0, 5342.0, 5413.0, 5252.0, 5717.0, 5677.0, 5347.0, 5704.0, 5394.0, 5662.0, 5426.0, 5341.0, 5651.0, 5332.0, 5623.0, 5572.0, 5447.0, 5669.0, 5672.0, 5521.0, 5722.0, 5693.0, 5368.0, 5689.0, 5337.0, 5665.0, 5503.0, 5532.0, 5570.0, 5289.0, 5431.0, 5445.0, 5524.0, 5557.0, 5420.0, 5422.0, 5266.0, 5514.0, 5378.0, 5553.0, 5460.0, 5297.0, 5255.0, 5387.0, 5371.0, 5385.0, 5279.0, 5268.0, 5590.0, 5291.0, 5309.0, 5580.0, 5416.0, 5491.0, 5581.0, 5695.0, 5253.0, 5592.0, 5548.0, 5344.0, 5375.0, 5612.0, 5351.0, 5534.0, 5470.0, 5484.0, 5363.0, 5706.0, 5374.0, 5628.0, 5671.0 (number of hits: 11)
6	5251	9	1	333	1	5402.0, 5649.0, 5695.0, 5493.0, 5263.0, 5549.0, 5711.0, 5472.0, 5316.0, 5590.0, 5604.0, 5430.0, 5440.0, 5267.0, 5569.0, 5442.0, 5669.0, 5416.0, 5324.0, 5392.0, 5665.0, 5479.0, 5588.0, 5388.0, 5718.0, 5350.0, 5620.0, 5625.0, 5438.0, 5506.0, 5552.0, 5581.0, 5557.0, 5361.0, 5648.0, 5297.0, 5340.0, 5638.0, 5654.0, 5694.0, 5483.0, 5265.0, 5313.0, 5432.0, 5303.0, 5551.0, 5687.0, 5679.0, 5660.0, 5393.0, 5424.0, 5397.0, 5616.0, 5447.0, 5586.0, 5655.0, 5531.0, 5292.0, 5541.0, 5255.0, 5289.0, 5290.0, 5351.0, 5681.0, 5563.0, 5386.0, 5355.0, 5523.0, 5533.0, 5334.0, 5710.0, 5345.0, 5475.0, 5348.0, 5332.0, 5311.0, 5662.0, 5495.0, 5473.0, 5698.0, 5404.0, 5546.0, 5545.0, 5380.0, 5518.0, 5524.0, 5645.0, 5468.0, 5715.0, 5306.0, 5692.0, 5428.0, 5693.0, 5708.0, 5467.0, 5492.0, 5677.0, 5562.0, 5449.0, 5634.0 (number of hits: 5)
7	5251	9	1	333	1	5273.0, 5369.0, 5422.0, 5617.0, 5458.0, 5546.0, 5529.0, 5621.0, 5286.0, 5358.0, 5400.0, 5385.0, 5446.0, 5678.0, 5568.0, 5347.0, 5639.0, 5636.0, 5361.0, 5342.0, 5692.0, 5663.0, 5386.0, 5381.0, 5615.0, 5478.0, 5627.0, 5560.0, 5329.0, 5565.0, 5622.0, 5723.0, 5310.0, 5561.0, 5301.0, 5709.0, 5338.0, 5682.0, 5265.0, 5490.0, 5452.0, 5499.0, 5590.0, 5431.0, 5379.0, 5296.0, 5479.0, 5532.0, 5579.0, 5299.0, 5531.0, 5645.0, 5610.0, 5498.0, 5672.0,

						5262.0, 5465.0, 5599.0, 5608.0, 5470.0, 5702.0, 5295.0, 5662.0, 5416.0, 5563.0, 5656.0, 5476.0, 5511.0, 5650.0, 5533.0, 5705.0, 5382.0, 5487.0, 5276.0, 5684.0, 5432.0, 5710.0, 5517.0, 5474.0, 5482.0, 5494.0, 5354.0, 5433.0, 5308.0, 5652.0, 5580.0, 5625.0, 5584.0, 5360.0, 5508.0, 5305.0, 5606.0, 5649.0, 5302.0, 5260.0, 5706.0, 5394.0, 5459.0, 5628.0, 5550.0 (number of hits: 6)
8	5251	9	1	333	1	5411.0, 5326.0, 5327.0, 5273.0, 5297.0, 5595.0, 5713.0, 5699.0, 5569.0, 5594.0, 5299.0, 5591.0, 5323.0, 5306.0, 5422.0, 5378.0, 5313.0, 5472.0, 5259.0, 5616.0, 5629.0, 5661.0, 5382.0, 5374.0, 5477.0, 5393.0, 5651.0, 5642.0, 5476.0, 5291.0, 5495.0, 5719.0, 5397.0, 5335.0, 5414.0, 5330.0, 5688.0, 5311.0, 5286.0, 5463.0, 5559.0, 5475.0, 5588.0, 5506.0, 5438.0, 5685.0, 5353.0, 5359.0, 5421.0, 5494.0, 5308.0, 5439.0, 5320.0, 5443.0, 5610.0, 5551.0, 5272.0, 5474.0, 5548.0, 5396.0, 5711.0, 5471.0, 5723.0, 5657.0, 5254.0, 5390.0, 5363.0, 5448.0, 5561.0, 5716.0, 5681.0, 5418.0, 5296.0, 5447.0, 5434.0, 5507.0, 5607.0, 5497.0, 5294.0, 5640.0, 5431.0, 5667.0, 5293.0, 5665.0, 5285.0, 5343.0, 5341.0, 5368.0, 5643.0, 5704.0, 5511.0, 5366.0, 5697.0, 5400.0, 5355.0, 5532.0, 5385.0, 5580.0, 5399.0, 5666.0 (number of hits: 6)
9	5251	9	1	333	1	5353.0, 5349.0, 5271.0, 5366.0, 5254.0, 5451.0, 5337.0, 5639.0, 5672.0, 5713.0, 5686.0, 5710.0, 5363.0, 5604.0, 5413.0, 5481.0, 5316.0, 5448.0, 5555.0, 5697.0, 5318.0, 5443.0, 5286.0, 5537.0, 5557.0, 5474.0, 5688.0, 5470.0, 5562.0, 5669.0, 5690.0, 5378.0, 5655.0, 5346.0, 5490.0, 5429.0, 5684.0, 5332.0, 5317.0, 5566.0, 5450.0, 5304.0, 5552.0, 5510.0, 5663.0, 5498.0, 5499.0, 5651.0, 5568.0, 5362.0, 5419.0, 5405.0, 5591.0, 5657.0, 5262.0, 5634.0, 5426.0, 5475.0, 5305.0, 5545.0, 5578.0, 5680.0, 5685.0, 5629.0, 5605.0, 5289.0, 5372.0, 5526.0, 5632.0, 5653.0, 5295.0, 5467.0, 5471.0, 5445.0, 5438.0, 5330.0, 5625.0, 5462.0, 5319.0, 5311.0, 5712.0, 5277.0, 5371.0, 5344.0, 5601.0, 5548.0, 5563.0, 5393.0, 5508.0, 5379.0, 5592.0, 5502.0, 5482.0, 5329.0, 5497.0, 5705.0, 5439.0, 5618.0, 5321.0, 5480.0 (number of hits: 6)
10	5251	9	1	333	1	5339.0, 5506.0, 5710.0, 5598.0, 5715.0, 5529.0, 5627.0, 5660.0, 5261.0, 5314.0, 5478.0, 5394.0, 5301.0, 5266.0, 5420.0, 5483.0, 5311.0, 5285.0, 5297.0, 5693.0, 5476.0, 5296.0, 5722.0, 5604.0, 5332.0, 5564.0, 5692.0, 5616.0, 5274.0, 5465.0, 5449.0, 5492.0, 5336.0, 5454.0, 5721.0, 5393.0, 5491.0, 5560.0, 5708.0, 5673.0, 5278.0, 5377.0, 5502.0, 5568.0, 5516.0

						5317.0, 5594.0, 5433.0, 5648.0, 5583.0, 5510.0, 5620.0, 5340.0, 5355.0, 5360.0, 5577.0, 5703.0, 5452.0, 5521.0, 5424.0, 5375.0, 5695.0, 5520.0, 5482.0, 5458.0, 5388.0, 5366.0, 5498.0, 5410.0, 5256.0, 5629.0, 5512.0, 5530.0, 5571.0, 5651.0, 5415.0, 5554.0, 5645.0, 5523.0, 5615.0, 5603.0, 5713.0, 5460.0, 5359.0, 5423.0, 5619.0, 5599.0, 5455.0, 5544.0, 5623.0, 5680.0, 5411.0, 5255.0, 5412.0, 5504.0, 5299.0, 5702.0, 5405.0, 5635.0, 5437.0 (number of hits: 7)
11	5251	9	1	333	1	5251.0, 5338.0, 5425.0, 5601.0, 5325.0, 5691.0, 5358.0, 5270.0, 5695.0, 5569.0, 5327.0, 5697.0, 5717.0, 5711.0, 5473.0, 5493.0, 5373.0, 5402.0, 5319.0, 5605.0, 5401.0, 5572.0, 5337.0, 5555.0, 5471.0, 5653.0, 5422.0, 5372.0, 5257.0, 5672.0, 5648.0, 5591.0, 5528.0, 5397.0, 5388.0, 5693.0, 5599.0, 5666.0, 5436.0, 5407.0, 5508.0, 5266.0, 5307.0, 5671.0, 5328.0, 5562.0, 5567.0, 5657.0, 5492.0, 5495.0, 5540.0, 5682.0, 5331.0, 5504.0, 5332.0, 5558.0, 5638.0, 5724.0, 5609.0, 5675.0, 5640.0, 5623.0, 5458.0, 5454.0, 5658.0, 5429.0, 5340.0, 5343.0, 5519.0, 5593.0, 5286.0, 5606.0, 5392.0, 5351.0, 5263.0, 5712.0, 5649.0, 5557.0, 5580.0, 5624.0, 5614.0, 5355.0, 5400.0, 5451.0, 5427.0, 5574.0, 5703.0, 5291.0, 5334.0, 5305.0, 5527.0, 5576.0, 5356.0, 5617.0, 5406.0, 5536.0, 5466.0, 5464.0, 5588.0, 5313.0 (number of hits: 6)
12	5290	9	1	333	1	5430.0, 5701.0, 5275.0, 5717.0, 5577.0, 5627.0, 5589.0, 5502.0, 5593.0, 5294.0, 5702.0, 5254.0, 5342.0, 5352.0, 5425.0, 5320.0, 5424.0, 5379.0, 5605.0, 5418.0, 5642.0, 5601.0, 5458.0, 5279.0, 5270.0, 5295.0, 5552.0, 5462.0, 5675.0, 5536.0, 5273.0, 5637.0, 5333.0, 5281.0, 5447.0, 5341.0, 5550.0, 5661.0, 5651.0, 5325.0, 5388.0, 5274.0, 5439.0, 5297.0, 5682.0, 5620.0, 5521.0, 5258.0, 5415.0, 5397.0, 5697.0, 5530.0, 5360.0, 5567.0, 5489.0, 5545.0, 5636.0, 5478.0, 5586.0, 5338.0, 5655.0, 5643.0, 5340.0, 5372.0, 5623.0, 5463.0, 5713.0, 5514.0, 5658.0, 5724.0, 5483.0, 5568.0, 5496.0, 5324.0, 5503.0, 5569.0, 5374.0, 5582.0, 5632.0, 5468.0, 5500.0, 5555.0, 5452.0, 5405.0, 5359.0, 5252.0, 5613.0, 5698.0, 5420.0, 5302.0, 5557.0, 5519.0, 5435.0, 5349.0, 5527.0, 5621.0, 5351.0, 5553.0, 5381.0, 5547.0 (number of hits: 16)
13	5290	9	1	333	1	5687.0, 5372.0, 5709.0, 5456.0, 5535.0, 5563.0, 5683.0, 5265.0, 5357.0, 5495.0, 5354.0, 5390.0, 5370.0, 5712.0, 5636.0, 5629.0, 5561.0, 5454.0, 5348.0, 5264.0, 5639.0, 5680.0, 5327.0, 5303.0, 5429.0, 5457.0, 5632.0, 5661.0, 5351.0, 5638.0, 5418.0, 5704.0, 5706.0, 5602.0, 5538.0

						5421.0, 5320.0, 5274.0, 5254.0, 5690.0, 5525.0, 5267.0, 5494.0, 5560.0, 5286.0, 5443.0, 5594.0, 5283.0, 5300.0, 5384.0, 5637.0, 5258.0, 5526.0, 5310.0, 5714.0, 5367.0, 5318.0, 5471.0, 5427.0, 5414.0, 5592.0, 5251.0, 5686.0, 5608.0, 5601.0, 5411.0, 5362.0, 5257.0, 5720.0, 5341.0, 5616.0, 5588.0, 5640.0, 5694.0, 5658.0, 5470.0, 5459.0, 5582.0, 5500.0, 5296.0, 5359.0, 5282.0, 5307.0, 5568.0, 5450.0, 5497.0, 5611.0, 5648.0, 5386.0, 5665.0, 5657.0, 5624.0, 5424.0, 5614.0, 5338.0, 5556.0, 5605.0, 5425.0, 5294.0, 5600.0 (number of hits: 20)
14	5290	9	1	333	1	5668.0, 5538.0, 5695.0, 5651.0, 5685.0, 5617.0, 5632.0, 5605.0, 5500.0, 5501.0, 5723.0, 5323.0, 5516.0, 5589.0, 5441.0, 5677.0, 5520.0, 5412.0, 5498.0, 5644.0, 5682.0, 5664.0, 5641.0, 5543.0, 5354.0, 5687.0, 5647.0, 5254.0, 5282.0, 5424.0, 5362.0, 5564.0, 5476.0, 5380.0, 5368.0, 5484.0, 5418.0, 5676.0, 5607.0, 5654.0, 5563.0, 5350.0, 5652.0, 5471.0, 5264.0, 5521.0, 5601.0, 5489.0, 5604.0, 5381.0, 5431.0, 5591.0, 5548.0, 5274.0, 5318.0, 5334.0, 5321.0, 5394.0, 5545.0, 5329.0, 5357.0, 5283.0, 5602.0, 5446.0, 5556.0, 5355.0, 5320.0, 5370.0, 5405.0, 5524.0, 5452.0, 5473.0, 5495.0, 5686.0, 5307.0, 5456.0, 5462.0, 5423.0, 5615.0, 5457.0, 5430.0, 5327.0, 5627.0, 5255.0, 5557.0, 5609.0, 5410.0, 5600.0, 5541.0, 5328.0, 5487.0, 5621.0, 5544.0, 5552.0, 5704.0, 5656.0, 5649.0, 5384.0, 5657.0, 5482.0 (number of hits: 13)
15	5290	9	1	333	1	5397.0, 5639.0, 5361.0, 5575.0, 5647.0, 5256.0, 5470.0, 5476.0, 5720.0, 5590.0, 5679.0, 5313.0, 5473.0, 5475.0, 5557.0, 5619.0, 5588.0, 5636.0, 5301.0, 5467.0, 5524.0, 5359.0, 5501.0, 5419.0, 5459.0, 5561.0, 5713.0, 5274.0, 5637.0, 5546.0, 5691.0, 5519.0, 5438.0, 5309.0, 5354.0, 5296.0, 5358.0, 5257.0, 5509.0, 5589.0, 5345.0, 5318.0, 5696.0, 5462.0, 5710.0, 5279.0, 5417.0, 5719.0, 5718.0, 5700.0, 5699.0, 5599.0, 5341.0, 5367.0, 5712.0, 5400.0, 5401.0, 5660.0, 5630.0, 5513.0, 5431.0, 5294.0, 5443.0, 5697.0, 5709.0, 5402.0, 5570.0, 5366.0, 5628.0, 5641.0, 5529.0, 5332.0, 5586.0, 5625.0, 5340.0, 5484.0, 5512.0, 5435.0, 5265.0, 5463.0, 5618.0, 5527.0, 5442.0, 5368.0, 5425.0, 5569.0, 5398.0, 5278.0, 5289.0, 5483.0, 5414.0, 5461.0, 5338.0, 5685.0, 5640.0, 5460.0, 5571.0, 5550.0, 5648.0, 5495.0 (number of hits: 13)
16	5290	9	1	333	1	5258.0, 5668.0, 5305.0, 5319.0, 5375.0, 5407.0, 5376.0, 5335.0, 5657.0, 5612.0, 5321.0, 5385.0, 5688.0, 5287.0, 5707.0, 5511.0, 5268.0, 5350.0, 5476.0, 5622.0, 5499.0, 5574.0, 5274.0, 5325.0, 5630.0,

						5560.0, 5546.0, 5633.0, 5568.0, 5579.0, 5479.0, 5675.0, 5582.0, 5348.0, 5441.0, 5330.0, 5282.0, 5596.0, 5551.0, 5554.0, 5662.0, 5388.0, 5447.0, 5294.0, 5539.0, 5645.0, 5397.0, 5425.0, 5618.0, 5673.0, 5693.0, 5690.0, 5537.0, 5371.0, 5571.0, 5377.0, 5542.0, 5421.0, 5466.0, 5557.0, 5548.0, 5402.0, 5277.0, 5359.0, 5366.0, 5333.0, 5381.0, 5600.0, 5503.0, 5474.0, 5514.0, 5480.0, 5484.0, 5357.0, 5354.0, 5701.0, 5414.0, 5496.0, 5250.0, 5355.0, 5351.0, 5336.0, 5709.0, 5545.0, 5396.0, 5603.0, 5722.0, 5370.0, 5523.0, 5307.0, 5443.0, 5422.0, 5649.0, 5409.0, 5697.0, 5260.0, 5435.0, 5555.0, 5408.0, 5710.0 (number of hits: 13)
17	5290	9	1	333	1	5431.0, 5398.0, 5405.0, 5704.0, 5541.0, 5303.0, 5450.0, 5362.0, 5514.0, 5519.0, 5679.0, 5339.0, 5694.0, 5713.0, 5608.0, 5560.0, 5722.0, 5285.0, 5278.0, 5668.0, 5538.0, 5258.0, 5434.0, 5543.0, 5422.0, 5501.0, 5261.0, 5353.0, 5448.0, 5635.0, 5629.0, 5304.0, 5558.0, 5586.0, 5681.0, 5533.0, 5414.0, 5507.0, 5415.0, 5445.0, 5580.0, 5663.0, 5505.0, 5354.0, 5469.0, 5627.0, 5402.0, 5429.0, 5561.0, 5333.0, 5644.0, 5671.0, 5286.0, 5355.0, 5442.0, 5626.0, 5421.0, 5453.0, 5388.0, 5646.0, 5547.0, 5279.0, 5321.0, 5657.0, 5645.0, 5290.0, 5697.0, 5564.0, 5518.0, 5690.0, 5562.0, 5677.0, 5349.0, 5724.0, 5276.0, 5536.0, 5327.0, 5399.0, 5606.0, 5332.0, 5683.0, 5274.0, 5628.0, 5512.0, 5251.0, 5526.0, 5723.0, 5717.0, 5408.0, 5494.0, 5612.0, 5589.0, 5314.0, 5640.0, 5284.0, 5630.0, 5714.0, 5423.0, 5709.0, 5253.0 (number of hits: 17)
18	5290	9	1	333	1	5585.0, 5456.0, 5405.0, 5264.0, 5395.0, 5255.0, 5314.0, 5578.0, 5422.0, 5316.0, 5497.0, 5506.0, 5418.0, 5486.0, 5600.0, 5663.0, 5278.0, 5370.0, 5550.0, 5522.0, 5439.0, 5711.0, 5531.0, 5703.0, 5472.0, 5322.0, 5315.0, 5591.0, 5416.0, 5571.0, 5266.0, 5532.0, 5447.0, 5526.0, 5650.0, 5719.0, 5681.0, 5451.0, 5707.0, 5575.0, 5348.0, 5573.0, 5464.0, 5268.0, 5286.0, 5320.0, 5384.0, 5308.0, 5708.0, 5347.0, 5493.0, 5620.0, 5505.0, 5546.0, 5552.0, 5484.0, 5261.0, 5310.0, 5651.0, 5688.0, 5329.0, 5253.0, 5621.0, 5331.0, 5561.0, 5277.0, 5515.0, 5557.0, 5619.0, 5415.0, 5374.0, 5471.0, 5327.0, 5453.0, 5388.0, 5373.0, 5530.0, 5427.0, 5519.0, 5724.0, 5570.0, 5496.0, 5675.0, 5365.0, 5652.0, 5376.0, 5559.0, 5612.0, 5295.0, 5366.0, 5328.0, 5409.0, 5520.0, 5500.0, 5658.0, 5412.0, 5403.0, 5623.0, 5706.0, 5682.0 (number of hits: 19)
19	5290	9	1	333	1	5430.0, 5651.0, 5688.0, 5492.0, 5486.0, 5717.0, 5506.0, 5476.0, 5263.0, 5267.0, 5496.0, 5405.0, 5434.0, 5650.0, 5604.0,

						5617.0, 5258.0, 5336.0, 5427.0, 5440.0, 5619.0, 5503.0, 5419.0, 5471.0, 5719.0, 5400.0, 5441.0, 5692.0, 5261.0, 5721.0, 5654.0, 5706.0, 5646.0, 5510.0, 5353.0, 5682.0, 5703.0, 5355.0, 5660.0, 5504.0, 5270.0, 5269.0, 5550.0, 5611.0, 5555.0, 5601.0, 5339.0, 5602.0, 5608.0, 5468.0, 5629.0, 5624.0, 5635.0, 5685.0, 5708.0, 5372.0, 5403.0, 5565.0, 5438.0, 5695.0, 5473.0, 5514.0, 5632.0, 5305.0, 5618.0, 5712.0, 5323.0, 5252.0, 5377.0, 5483.0, 5568.0, 5605.0, 5522.0, 5404.0, 5319.0, 5410.0, 5367.0, 5527.0, 5569.0, 5672.0, 5683.0, 5378.0, 5541.0, 5533.0, 5414.0, 5562.0, 5328.0, 5343.0, 5298.0, 5399.0, 5545.0, 5679.0, 5591.0, 5509.0, 5668.0, 5560.0, 5449.0, 5498.0, 5475.0, 5576.0 (number of hits: 12)
20	5290	9	1	333	1	5492.0, 5270.0, 5550.0, 5402.0, 5265.0, 5317.0, 5608.0, 5649.0, 5308.0, 5255.0, 5413.0, 5353.0, 5597.0, 5544.0, 5700.0, 5484.0, 5660.0, 5542.0, 5536.0, 5639.0, 5543.0, 5522.0, 5403.0, 5259.0, 5290.0, 5310.0, 5339.0, 5681.0, 5674.0, 5348.0, 5478.0, 5312.0, 5396.0, 5275.0, 5556.0, 5611.0, 5457.0, 5422.0, 5313.0, 5439.0, 5405.0, 5510.0, 5589.0, 5701.0, 5343.0, 5630.0, 5716.0, 5291.0, 5627.0, 5318.0, 5429.0, 5328.0, 5303.0, 5690.0, 5350.0, 5599.0, 5397.0, 5376.0, 5504.0, 5338.0, 5274.0, 5387.0, 5495.0, 5475.0, 5520.0, 5465.0, 5683.0, 5333.0, 5423.0, 5366.0, 5445.0, 5612.0, 5252.0, 5371.0, 5253.0, 5444.0, 5354.0, 5625.0, 5383.0, 5285.0, 5561.0, 5524.0, 5515.0, 5469.0, 5379.0, 5335.0, 5378.0, 5629.0, 5707.0, 5715.0, 5558.0, 5666.0, 5531.0, 5659.0, 5591.0, 5363.0, 5574.0, 5250.0, 5584.0, 5605.0 (number of hits: 19)
21	5329	9	1	333	1	5499.0, 5718.0, 5473.0, 5474.0, 5440.0, 5352.0, 5598.0, 5483.0, 5253.0, 5686.0, 5278.0, 5569.0, 5413.0, 5523.0, 5369.0, 5418.0, 5536.0, 5293.0, 5443.0, 5389.0, 5561.0, 5403.0, 5355.0, 5448.0, 5505.0, 5274.0, 5608.0, 5300.0, 5373.0, 5378.0, 5401.0, 5540.0, 5504.0, 5417.0, 5564.0, 5422.0, 5638.0, 5715.0, 5365.0, 5691.0, 5510.0, 5279.0, 5357.0, 5447.0, 5377.0, 5335.0, 5639.0, 5535.0, 5268.0, 5423.0, 5298.0, 5486.0, 5612.0, 5478.0, 5286.0, 5350.0, 5424.0, 5400.0, 5711.0, 5336.0, 5672.0, 5272.0, 5339.0, 5567.0, 5705.0, 5255.0, 5328.0, 5363.0, 5566.0, 5558.0, 5469.0, 5465.0, 5250.0, 5415.0, 5554.0, 5634.0, 5618.0, 5599.0, 5462.0, 5539.0, 5441.0, 5463.0, 5479.0, 5723.0, 5284.0, 5497.0, 5472.0, 5395.0, 5679.0, 5586.0, 5475.0, 5368.0, 5435.0, 5519.0, 5322.0, 5260.0, 5391.0, 5508.0, 5258.0, 5661.0 (number of hits: 14)
22	5329	9	1	333	1	5322.0, 5703.0, 5368.0, 5620.0, 5550.0,

						5519.0, 5356.0, 5378.0, 5287.0, 5260.0, 5600.0, 5479.0, 5269.0, 5624.0, 5482.0, 5358.0, 5507.0, 5688.0, 5592.0, 5602.0, 5308.0, 5526.0, 5585.0, 5701.0, 5485.0, 5596.0, 5492.0, 5686.0, 5361.0, 5271.0, 5713.0, 5397.0, 5344.0, 5331.0, 5635.0, 5385.0, 5466.0, 5581.0, 5317.0, 5586.0, 5573.0, 5509.0, 5488.0, 5529.0, 5630.0, 5625.0, 5329.0, 5496.0, 5301.0, 5537.0, 5603.0, 5475.0, 5297.0, 5413.0, 5569.0, 5652.0, 5422.0, 5616.0, 5263.0, 5382.0, 5292.0, 5462.0, 5272.0, 5478.0, 5274.0, 5279.0, 5695.0, 5434.0, 5514.0, 5642.0, 5671.0, 5605.0, 5659.0, 5408.0, 5328.0, 5426.0, 5425.0, 5638.0, 5580.0, 5623.0, 5336.0, 5516.0, 5680.0, 5558.0, 5429.0, 5714.0, 5394.0, 5333.0, 5524.0, 5386.0, 5694.0, 5631.0, 5266.0, 5407.0, 5283.0, 5646.0, 5583.0, 5527.0, 5319.0, 5410.0 (number of hits: 16)
23	5329	9	1	333	1	5556.0, 5434.0, 5633.0, 5351.0, 5548.0, 5606.0, 5518.0, 5407.0, 5697.0, 5396.0, 5323.0, 5447.0, 5682.0, 5291.0, 5584.0, 5341.0, 5664.0, 5508.0, 5263.0, 5463.0, 5588.0, 5598.0, 5557.0, 5313.0, 5699.0, 5569.0, 5632.0, 5579.0, 5411.0, 5602.0, 5269.0, 5521.0, 5658.0, 5502.0, 5573.0, 5376.0, 5610.0, 5337.0, 5377.0, 5596.0, 5343.0, 5356.0, 5656.0, 5387.0, 5665.0, 5688.0, 5691.0, 5286.0, 5564.0, 5361.0, 5444.0, 5439.0, 5309.0, 5544.0, 5486.0, 5473.0, 5316.0, 5345.0, 5468.0, 5353.0, 5721.0, 5394.0, 5604.0, 5527.0, 5580.0, 5541.0, 5589.0, 5717.0, 5493.0, 5512.0, 5310.0, 5662.0, 5615.0, 5500.0, 5599.0, 5526.0, 5384.0, 5578.0, 5393.0, 5372.0, 5342.0, 5300.0, 5335.0, 5539.0, 5576.0, 5677.0, 5689.0, 5430.0, 5405.0, 5367.0, 5419.0, 5703.0, 5461.0, 5704.0, 5701.0, 5424.0, 5401.0, 5266.0, 5273.0, 5533.0 (number of hits: 18)
24	5329	9	1	333	1	5505.0, 5506.0, 5400.0, 5462.0, 5502.0, 5548.0, 5545.0, 5615.0, 5512.0, 5623.0, 5685.0, 5689.0, 5373.0, 5514.0, 5635.0, 5300.0, 5265.0, 5684.0, 5425.0, 5324.0, 5625.0, 5351.0, 5637.0, 5658.0, 5540.0, 5398.0, 5592.0, 5372.0, 5714.0, 5385.0, 5332.0, 5672.0, 5686.0, 5507.0, 5471.0, 5344.0, 5690.0, 5362.0, 5374.0, 5717.0, 5267.0, 5673.0, 5263.0, 5670.0, 5534.0, 5603.0, 5710.0, 5608.0, 5479.0, 5448.0, 5312.0, 5642.0, 5513.0, 5552.0, 5415.0, 5667.0, 5270.0, 5721.0, 5371.0, 5282.0, 5493.0, 5609.0, 5447.0, 5454.0, 5319.0, 5395.0, 5699.0, 5449.0, 5365.0, 5406.0, 5524.0, 5388.0, 5692.0, 5435.0, 5331.0, 5466.0, 5345.0, 5326.0, 5587.0, 5422.0, 5604.0, 5429.0, 5643.0, 5666.0, 5653.0, 5410.0, 5478.0, 5311.0, 5496.0, 5368.0, 5555.0, 5504.0, 5318.0, 5597.0, 5619.0, 5288.0, 5268.0, 5564.0, 5588.0, 5525.0

						(number of hits: 14)
25	5329	9	1	333	1	5459.0, 5330.0, 5430.0, 5571.0, 5626.0, 5602.0, 5561.0, 5556.0, 5491.0, 5320.0, 5311.0, 5686.0, 5586.0, 5478.0, 5593.0, 5519.0, 5398.0, 5289.0, 5432.0, 5659.0, 5623.0, 5492.0, 5522.0, 5636.0, 5692.0, 5329.0, 5638.0, 5305.0, 5268.0, 5371.0, 5531.0, 5670.0, 5275.0, 5325.0, 5468.0, 5709.0, 5645.0, 5409.0, 5447.0, 5504.0, 5475.0, 5263.0, 5589.0, 5343.0, 5595.0, 5526.0, 5576.0, 5503.0, 5462.0, 5333.0, 5534.0, 5359.0, 5381.0, 5684.0, 5304.0, 5567.0, 5557.0, 5540.0, 5612.0, 5592.0, 5477.0, 5382.0, 5278.0, 5517.0, 5307.0, 5584.0, 5683.0, 5580.0, 5642.0, 5426.0, 5510.0, 5698.0, 5570.0, 5708.0, 5253.0, 5414.0, 5666.0, 5482.0, 5628.0, 5308.0, 5396.0, 5679.0, 5453.0, 5663.0, 5303.0, 5639.0, 5450.0, 5317.0, 5489.0, 5282.0, 5310.0, 5658.0, 5367.0, 5591.0, 5380.0, 5549.0, 5397.0, 5344.0, 5597.0, 5587.0
						(number of hits: 17)
26	5329	9	1	333	1	5404.0, 5497.0, 5262.0, 5382.0, 5674.0, 5501.0, 5606.0, 5658.0, 5626.0, 5566.0, 5298.0, 5569.0, 5518.0, 5373.0, 5685.0, 5261.0, 5484.0, 5388.0, 5624.0, 5663.0, 5381.0, 5418.0, 5619.0, 5505.0, 5353.0, 5320.0, 5490.0, 5279.0, 5539.0, 5616.0, 5292.0, 5498.0, 5455.0, 5519.0, 5592.0, 5489.0, 5252.0, 5712.0, 5650.0, 5340.0, 5477.0, 5268.0, 5322.0, 5653.0, 5654.0, 5493.0, 5366.0, 5618.0, 5625.0, 5720.0, 5525.0, 5263.0, 5562.0, 5682.0, 5631.0, 5705.0, 5603.0, 5585.0, 5309.0, 5346.0, 5587.0, 5543.0, 5581.0, 5327.0, 5278.0, 5458.0, 5601.0, 5503.0, 5399.0, 5698.0, 5317.0, 5354.0, 5374.0, 5630.0, 5655.0, 5534.0, 5707.0, 5668.0, 5397.0, 5683.0, 5301.0, 5369.0, 5352.0, 5466.0, 5649.0, 5304.0, 5370.0, 5328.0, 5639.0, 5530.0, 5549.0, 5436.0, 5578.0, 5302.0, 5467.0, 5700.0, 5718.0, 5437.0, 5675.0, 5574.0
						(number of hits: 17)
27	5329	9	1	333	1	5352.0, 5466.0, 5624.0, 5714.0, 5311.0, 5553.0, 5469.0, 5441.0, 5333.0, 5481.0, 5503.0, 5722.0, 5516.0, 5613.0, 5629.0, 5521.0, 5584.0, 5334.0, 5257.0, 5606.0, 5335.0, 5487.0, 5305.0, 5422.0, 5365.0, 5418.0, 5316.0, 5594.0, 5549.0, 5344.0, 5632.0, 5679.0, 5357.0, 5321.0, 5661.0, 5672.0, 5269.0, 5630.0, 5399.0, 5539.0, 5671.0, 5685.0, 5319.0, 5379.0, 5581.0, 5374.0, 5482.0, 5571.0, 5534.0, 5313.0, 5639.0, 5378.0, 5479.0, 5449.0, 5266.0, 5586.0, 5437.0, 5511.0, 5673.0, 5636.0, 5718.0, 5391.0, 5301.0, 5544.0, 5568.0, 5265.0, 5389.0, 5253.0, 5377.0, 5645.0, 5489.0, 5658.0, 5616.0, 5403.0, 5545.0, 5522.0, 5330.0, 5387.0, 5518.0, 5473.0, 5289.0, 5647.0, 5543.0, 5306.0, 5338.0, 5709.0, 5590.0, 5439.0, 5328.0, 5446.0

						5447.0, 5327.0, 5455.0, 5258.0, 5589.0, 5448.0, 5274.0, 5263.0, 5483.0, 5612.0 (number of hits: 19)
28	5329	9	1	333	1	5344.0, 5349.0, 5505.0, 5452.0, 5558.0, 5259.0, 5690.0, 5476.0, 5510.0, 5651.0, 5710.0, 5556.0, 5562.0, 5482.0, 5693.0, 5685.0, 5576.0, 5492.0, 5687.0, 5258.0, 5560.0, 5661.0, 5432.0, 5295.0, 5342.0, 5303.0, 5345.0, 5418.0, 5457.0, 5281.0, 5509.0, 5673.0, 5373.0, 5493.0, 5555.0, 5631.0, 5611.0, 5697.0, 5644.0, 5625.0, 5350.0, 5470.0, 5377.0, 5627.0, 5288.0, 5495.0, 5268.0, 5549.0, 5397.0, 5532.0, 5635.0, 5277.0, 5507.0, 5501.0, 5566.0, 5545.0, 5660.0, 5286.0, 5652.0, 5347.0, 5533.0, 5594.0, 5634.0, 5368.0, 5604.0, 5376.0, 5273.0, 5464.0, 5250.0, 5628.0, 5694.0, 5255.0, 5559.0, 5450.0, 5610.0, 5297.0, 5317.0, 5707.0, 5553.0, 5514.0, 5708.0, 5455.0, 5567.0, 5721.0, 5683.0, 5396.0, 5479.0, 5292.0, 5600.0, 5280.0, 5260.0, 5353.0, 5536.0, 5527.0, 5469.0, 5438.0, 5504.0, 5380.0, 5498.0, 5699.0 (number of hits: 12)
29	5329	9	1	333	1	5284.0, 5298.0, 5413.0, 5267.0, 5261.0, 5311.0, 5282.0, 5518.0, 5312.0, 5658.0, 5692.0, 5500.0, 5355.0, 5440.0, 5607.0, 5484.0, 5339.0, 5454.0, 5506.0, 5664.0, 5508.0, 5447.0, 5610.0, 5465.0, 5532.0, 5597.0, 5255.0, 5321.0, 5653.0, 5539.0, 5371.0, 5722.0, 5534.0, 5505.0, 5681.0, 5598.0, 5319.0, 5365.0, 5536.0, 5472.0, 5498.0, 5631.0, 5332.0, 5427.0, 5377.0, 5590.0, 5396.0, 5708.0, 5676.0, 5429.0, 5446.0, 5567.0, 5360.0, 5520.0, 5275.0, 5280.0, 5585.0, 5417.0, 5619.0, 5577.0, 5503.0, 5512.0, 5353.0, 5480.0, 5555.0, 5481.0, 5501.0, 5448.0, 5288.0, 5289.0, 5714.0, 5504.0, 5537.0, 5666.0, 5475.0, 5260.0, 5434.0, 5663.0, 5263.0, 5551.0, 5442.0, 5596.0, 5391.0, 5499.0, 5449.0, 5513.0, 5587.0, 5538.0, 5336.0, 5317.0, 5646.0, 5296.0, 5639.0, 5424.0, 5271.0, 5388.0, 5299.0, 5713.0, 5564.0, 5257.0 (number of hits: 15)
30	5329	9	1	333	1	5430.0, 5564.0, 5612.0, 5390.0, 5708.0, 5422.0, 5627.0, 5555.0, 5484.0, 5623.0, 5451.0, 5680.0, 5514.0, 5579.0, 5293.0, 5367.0, 5399.0, 5315.0, 5671.0, 5527.0, 5365.0, 5295.0, 5591.0, 5657.0, 5593.0, 5508.0, 5510.0, 5529.0, 5583.0, 5436.0, 5462.0, 5321.0, 5588.0, 5489.0, 5307.0, 5494.0, 5698.0, 5434.0, 5692.0, 5715.0, 5582.0, 5483.0, 5547.0, 5465.0, 5429.0, 5369.0, 5535.0, 5336.0, 5394.0, 5410.0, 5301.0, 5411.0, 5325.0, 5358.0, 5368.0, 5260.0, 5688.0, 5500.0, 5458.0, 5521.0, 5630.0, 5319.0, 5586.0, 5338.0, 5517.0, 5409.0, 5305.0, 5468.0, 5449.0, 5354.0, 5303.0, 5446.0, 5475.0, 5304.0, 5414.0, 5438.0, 5654.0, 5261.0, 5392.0, 5628.0,

						5622.0, 5683.0, 5380.0, 5647.0, 5324.0, 5668.0, 5374.0, 5662.0, 5631.0, 5638.0, 5381.0, 5437.0, 5639.0, 5696.0, 5519.0, 5643.0, 5497.0, 5713.0, 5719.0, 5309.0 (number of hits: 19)
--	--	--	--	--	--	--

A.4 160 MHz Bandwidth @ 5250 MHz

Table-1A/1B Radar Type 1A/1B Statistical Performance

Trial #	Fc (MHz)	Pulse/Burst	Pulse Width (µS)	PRI (µs)	Detection (1:yes; 0:no)
1	5250	76	1	698	1
2	5250	57	1	938	1
3	5250	65	1	818	1
4	5250	83	1	638	1
5	5250	74	1	718	1
6	5290	62	1	858	1
7	5290	68	1	778	1
8	5290	63	1	838	1
9	5290	81	1	658	1
10	5290	70	1	758	1
11	5330	102	1	518	1
12	5330	18	1	3066	1
13	5330	86	1	618	1
14	5330	61	1	878	1
15	5330	67	1	798	1
16	5250	19	1	2932	1
17	5250	28	1	1932	1
18	5250	37	1	1427	1
19	5250	27	1	1989	1
20	5250	19	1	2805	1
21	5290	33	1	1604	1
22	5290	51	1	1044	1
23	5290	61	1	873	1
24	5290	41	1	1299	1
25	5290	98	1	539	1
26	5330	87	1	609	1
27	5330	20	1	2713	1
28	5330	81	1	655	1
29	5330	36	1	1492	1
30	5330	38	1	1410	1
Detection Percentage: 100 % (>60%)					

Table-2 Radar Type 2 Statistical Performance

Trial #	Fc (MHz)	Pulse/Burst	Pulse Width (μS)	PRI (μs)	Detection (1:yes; 0:no)
1	5250	23	1.9	167	1
2	5250	29	3.9	224	1
3	5250	29	4.7	163	1
4	5250	26	4.8	228	1
5	5250	25	1.4	160	1
6	5250	23	1.9	178	1
7	5250	25	2.9	211	1
8	5250	23	1.7	171	1
9	5250	26	4	198	1
10	5250	25	4.7	181	1
11	5290	23	1.8	215	1
12	5290	23	1.3	202	1
13	5290	23	4	209	1
14	5290	25	1.8	193	1
15	5290	24	1.7	190	1
16	5290	23	2.1	154	1
17	5290	28	2.9	185	1
18	5290	23	3.9	173	1
19	5290	23	3.3	157	1
20	5290	26	4.7	183	1
21	5330	29	2.4	181	1
22	5330	26	3.7	204	1
23	5330	23	3.4	151	1
24	5330	24	3.3	219	1
25	5330	29	2.8	222	1
26	5330	28	2.9	225	1
27	5330	28	1.7	155	1
28	5330	27	1.4	198	1
29	5330	24	1	152	1
30	5330	28	3	200	1
Detection Percentage: 100 % (>60%)					

Table-3 Radar Type 3 Statistical Performance

Trial #	Fc (MHz)	Pulse/Burst	Pulse Width (μS)	PRI (μs)	Detection (1:yes; 0:no)
1	5250	16	8.9	215	1
2	5250	18	9.3	316	1
3	5250	17	7.2	253	1
4	5250	18	6	476	1
5	5250	16	7.8	237	1
6	5250	17	8.8	289	1
7	5250	17	6.2	384	1
8	5250	18	9.2	243	1
9	5250	16	9.7	255	1
10	5250	16	6.2	410	1
11	5290	17	6.2	454	1
12	5290	16	6.5	356	1
13	5290	17	7.4	204	1
14	5290	16	9.3	335	1
15	5290	16	6.7	471	1
16	5290	16	8.4	280	1
17	5290	18	6.5	464	1
18	5290	16	9.7	340	1
19	5290	16	8.9	232	1
20	5290	16	6.8	202	1
21	5330	17	8.5	225	1
22	5330	16	8	404	1
23	5330	17	8.2	230	1
24	5330	18	6.8	224	1
25	5330	18	7.7	496	1
26	5330	17	7.7	307	1
27	5330	16	6.8	330	1
28	5330	16	9.7	272	1
29	5330	17	6.1	390	1
30	5330	16	7.1	435	1
Detection Percentage: 100 % (>60%)					

Table-4 Radar Type 4 Statistical Performance

Trial #	Fc (MHz)	Pulse/Burst	Pulse Width (μS)	PRI (μs)	Detection (1:yes; 0:no)
1	5250	13	17.1	274	1
2	5250	15	17.3	423	1
3	5250	15	17.9	398	1
4	5250	12	14.9	499	1
5	5250	13	18	235	1
6	5250	14	17.9	452	1
7	5250	13	17.3	316	1
8	5250	16	12.6	499	1
9	5250	14	13.8	491	1
10	5250	15	11.5	271	1
11	5290	14	19.8	287	1
12	5290	12	16.7	401	1
13	5290	13	12.5	265	1
14	5290	12	17.8	425	1
15	5290	12	14	329	1
16	5290	16	12.1	314	1
17	5290	16	18.7	289	1
18	5290	13	16.5	375	1
19	5290	16	18	272	1
20	5290	13	17.9	328	1
21	5330	16	11.5	261	1
22	5330	12	14.1	203	1
23	5330	13	13.5	265	1
24	5330	15	12.2	321	1
25	5330	16	17	498	1
26	5330	14	18.6	424	1
27	5330	15	11.5	205	1
28	5330	16	15.2	336	1
29	5330	14	14.6	242	1
30	5330	14	11.6	432	1
Detection Percentage: 100 % (>60%)					

Table-5 Radar Type 5 Statistical Performance

Trial #	Fc (MHz)	Detection (1:yes; 0:no)
1	5290.0	1
2	5290.0	1
3	5290.0	1
4	5290.0	1
5	5290.0	1
6	5290.0	1
7	5290.0	1
8	5290.0	1
9	5290.0	1
10	5290.0	1
11	5254.8	1
12	5257.6	0
13	5252.4	1
14	5254.0	1
15	5257.6	0
16	5252.8	1
17	5254.8	1
18	5254.8	1
19	5254.8	1
20	5254.0	1
21	5326.8	1
22	5323.6	1
23	5327.2	1
24	5325.6	1
25	5326.4	1
26	5324.4	1
27	5326.8	1
28	5322.8	1
29	5324.4	1
30	5324.4	1
Detection Percentage: 93.33 % (>80%)		

Bin5 Statistics 1

Trial #	Pulse	Chirp (MHz)	Pulse Width (µS)	Pulse 1-2 spacing (µS)	Pulse 2-3 spacing (µS)	Pulse Start(S)	Detection (1:yes; 0:no)
0	2	11	60.5	1834		0.598449	1
1	3	11	66.9	1025	1487	1.611787	
2	1	11	85.2			1.90927	
3	2	11	67	1108		3.299615	
4	2	11	92.9	1218		3.632053	
5	1	11	79.8			4.683754	
6	2	11	91.2	1031		5.629696	
7	1	11	88.6			6.372888	
8	2	11	77.9	1806		7.28137	
9	2	11	89.8	1692		8.177228	
10	2	11	63	1196		8.603092	
11	2	11	50.8	1815		9.486101	
12	3	11	64.8	1640	1032	10.404167	
13	2	11	98.2	1354		11.430728	

Bin5 Statistics 2

Trial #	Pulse	Chirp (MHz)	Pulse Width (µS)	Pulse 1-2 spacing (µS)	Pulse 2-3 spacing (µS)	Pulse Start(S)	Detection (1:yes; 0:no)
0	1	6	58.8			0.172428	1
1	3	6	81.6	1496	1610	1.164053	
2	2	6	83.4	1906		2.026664	
3	2	6	76.9	1896		2.814463	
4	2	6	86.8	1543		3.451092	
5	3	6	78.7	1595	1905	4.468979	
6	2	6	63.6	1527		4.98093	
7	2	6	78.5	1782		5.31676	
8	3	6	86.1	1195	1697	6.711724	
9	2	6	85.6	1314		6.805734	
10	2	6	95.5	1780		7.895564	
11	2	6	89.3	1738		8.522034	
12	2	6	68.9	1271		9.053067	
13	2	6	92.1	1853		10.043163	
14	3	6	93.2	1360	1678	11.15564	
15	2	6	99.5	1188		11.311686	

Bin5 Statistics 3

Trial #	Pulse	Chirp (MHz)	Pulse Width (µS)	Pulse 1-2 spacing (uS)	Pulse 2-3 spacing (uS)	Pulse Start(S)	Detection (1:yes; 0:no)
0	1	6	56.4			0.044472	1
1	2	6	74	1966		0.916455	
2	3	6	75.8	1060	1125	1.691467	
3	2	6	77.6	1008		2.496349	
4	3	6	61.8	1512	1783	3.401736	
5	2	6	60.2	1990		3.85886	
6	1	6	75.4			4.752715	
7	1	6	98.8			5.249203	
8	2	6	91.1	1317		5.751092	
9	1	6	79.2			6.632132	
10	2	6	75.1	1197		7.682408	
11	2	6	83.9	1838		8.175074	
12	2	6	55.3	1779		8.704099	
13	2	6	83.3	1359		9.540283	
14	2	6	88.4	1768		10.347739	
15	2	6	65.3	1076		10.604788	
16	2	6	56.5	1579		11.682953	

Bin5 Statistics 4

Trial #	Pulse	Chirp (MHz)	Pulse Width (µS)	Pulse 1-2 spacing (uS)	Pulse 2-3 spacing (uS)	Pulse Start(S)	Detection (1:yes; 0:no)
0	1	15	71.7			0.405477	1
1	2	15	58.7	1978		1.738692	
2	3	15	98.7	1167	1884	1.953031	
3	2	15	93.1	1402		3.517252	
4	2	15	73.4	1913		4.079332	
5	2	15	56.6	1061		4.728169	
6	1	15	81.5			6.118411	
7	2	15	83.9	1116		7.087208	
8	2	15	64.6	1034		8.156936	
9	2	15	58.9	1071		9.163413	
10	2	15	55.2	1584		9.244245	
11	3	15	99.8	1749	1018	10.618551	
12	1	15	86.5			11.606399	

Bin5 Statistics 5

Trial #	Pulse	Chirp (MHz)	Pulse Width (µS)	Pulse 1-2 spacing (uS)	Pulse 2-3 spacing (uS)	Pulse Start(S)	Detection (1:yes; 0:no)
0	2	8	52.8	1866		0.115015	1
1	2	8	84.4	1178		1.325242	
2	2	8	98.9	1206		1.73825	
3	1	8	63.6			2.332133	
4	3	8	84.9	1586	1146	3.481566	
5	1	8	79.7			4.37799	
6	3	8	54.8	1063	1333	5.151688	
7	2	8	91.7	1310		5.894532	
8	2	8	93.3	1157		6.584315	
9	3	8	94	1837	1349	7.257818	
10	2	8	91.6	1486		7.779421	
11	3	8	73.7	1894	1431	8.700129	
12	2	8	81.4	1057		9.270072	
13	1	8	61			9.848492	
14	1	8	95.6			11.019931	
15	1	8	64.1			11.421798	

Bin5 Statistics 6

Trial #	Pulse	Chirp (MHz)	Pulse Width (µS)	Pulse 1-2 spacing (uS)	Pulse 2-3 spacing (uS)	Pulse Start(S)	Detection (1:yes; 0:no)
0	3	13	70.7	1721	1269	0.42078	1
1	2	13	61.1	1194		0.615183	
2	1	13	75.8			1.656516	
3	2	13	96.8	1670		2.146104	
4	2	13	62.6	1833		2.94584	
5	3	13	96.6	1002	1932	3.047568	
6	2	13	58.2	1329		3.849166	
7	2	13	79.2	1501		4.700956	
8	2	13	61.7	1571		5.223557	
9	2	13	55.6	1694		5.610992	
10	1	13	67.8			6.291681	
11	3	13	57.5	1872	1992	7.148364	
12	1	13	74.5			7.53648	
13	3	13	75.5	1953	1340	8.051964	
14	2	13	83.4	1543		8.433717	
15	3	13	85.9	1229	1751	9.200235	
16	2	13	88.8	1661		9.902541	
17	2	13	54.4	1536		10.618095	
18	3	13	65.1	1836	1202	11.291906	
19	1	13	54.2			11.522942	

Bin5 Statistics 7

Trial #	Pulse	Chirp (MHz)	Pulse Width (µS)	Pulse 1-2 spacing (uS)	Pulse 2-3 spacing (uS)	Pulse Start(S)	Detection (1:yes; 0:no)
0	1	15	79.5			1.035286	1
1	3	15	95.4	1840	1127	2.309368	
2	2	15	88.1	1883		3.214751	
3	3	15	94.1	1867	1527	4.405037	
4	3	15	64.5	1966	1655	5.8881	
5	2	15	73.7	1193		6.140716	
6	2	15	73.8	1857		7.677846	
7	2	15	59.3	1274		8.850925	
8	2	15	80.5	1076		10.750258	
9	2	15	50.4	1638		11.104617	

Bin5 Statistics 8

Trial #	Pulse	Chirp (MHz)	Pulse Width (µS)	Pulse 1-2 spacing (uS)	Pulse 2-3 spacing (uS)	Pulse Start(S)	Detection (1:yes; 0:no)
0	1	7	71.5			0.271198	1
1	3	7	80.5	1445	1603	1.909907	
2	2	7	61.7	1191		2.430547	
3	2	7	58.7	1411		3.721903	
4	2	7	76.9	1130		4.227682	
5	2	7	67.9	1146		5.802641	
6	2	7	94.6	1161		6.650413	
7	2	7	76.8	1373		7.095345	
8	1	7	71.2			8.525287	
9	1	7	79.5			9.907196	
10	3	7	86.7	1501	1152	10.515593	
11	1	7	67.2			11.094562	

Bin5 Statistics 9

Trial #	Pulse	Chirp (MHz)	Pulse Width (µS)	Pulse 1-2 spacing (uS)	Pulse 2-3 spacing (uS)	Pulse Start(S)	Detection (1:yes; 0:no)
0	2	6	52.9	1898		0.300256	1
1	2	6	92.7	1939		1.280885	
2	3	6	58.7	1731	1021	2.640237	
3	2	6	67.8	1975		4.047432	
4	1	6	98.8			5.92661	
5	2	6	56.6	1420		6.995041	
6	1	6	85.4			7.508369	
7	2	6	68.8	1357		8.656464	
8	3	6	80.2	1172	1418	9.981509	
9	3	6	99	1872	1830	10.922377	

Bin5 Statistics 10

Trial #	Pulse	Chirp (MHz)	Pulse Width (µS)	Pulse 1-2 spacing (uS)	Pulse 2-3 spacing (uS)	Pulse Start(S)	Detection (1:yes; 0:no)
0	1	6	84.8			1.170525	1
1	3	6	55.5	1797	1947	1.677585	
2	3	6	55.6	1583	1285	3.314858	
3	2	6	91.7	1634		3.733893	
4	3	6	81.8	1892	1058	5.105415	
5	2	6	89.4	1414		6.928364	
6	2	6	94.8	1707		8.067091	
7	3	6	85.5	1582	1209	9.163802	
8	1	6	76.8			9.994988	
9	2	6	97.9	1205		11.792636	

Bin5 Statistics 11

Trial #	Pulse	Chirp (MHz)	Pulse Width (µS)	Pulse 1-2 spacing (uS)	Pulse 2-3 spacing (uS)	Pulse Start(S)	Detection (1:yes; 0:no)
0	2	12	69.5	1405		0.58215	1
1	2	12	75.2	1783		1.146525	
2	2	12	77.4	1018		1.526919	
3	3	12	92	1810	1766	2.372019	
4	3	12	89.5	1078	1767	3.086344	
5	1	12	59.2			3.725086	
6	2	12	76.3	1594		4.149213	
7	2	12	50.4	1367		4.471741	
8	2	12	95.4	1691		5.352908	
9	1	12	79.9			5.804007	
10	2	12	89.2	1750		6.794349	
11	2	12	82.2	1421		7.42897	
12	1	12	81.4			7.843202	
13	1	12	97.9			8.475891	
14	3	12	64.7	1337	1901	8.987336	
15	2	12	96.3	1702		10.044178	
16	1	12	96.2			10.683809	
17	1	12	87.4			10.737273	
18	2	12	54.2	1825		11.75633	

Bin5 Statistics 12

Trial #	Pulse	Chirp (MHz)	Pulse Width (μS)	Pulse 1-2 spacing (uS)	Pulse 2-3 spacing (uS)	Pulse Start(S)	Detection (1:yes; 0:no)
0	2	19	64.8	1747		0.645594	0
1	2	19	89.8	1781		0.742172	
2	2	19	84.7	1417		2.09328	
3	2	19	71.5	1591		2.181613	
4	3	19	88.7	1666	1629	3.256995	
5	3	19	50.9	1436	1279	4.1038	
6	3	19	73	1574	1524	4.459676	
7	3	19	89.5	1382	1371	5.1223	
8	1	19	65.3			6.030073	
9	1	19	58.9			6.872888	
10	3	19	77.3	1308	1544	7.550789	
11	2	19	85.3	1332		8.419158	
12	2	19	81.5	1895		9.042735	
13	2	19	71.2	1623		9.704566	
14	2	19	54.6	1254		10.491142	
15	2	19	81.6	1598		10.94613	
16	2	19	62.8	1737		11.66506	

Bin5 Statistics 13

Trial #	Pulse	Chirp (MHz)	Pulse Width (µS)	Pulse 1-2 spacing (µS)	Pulse 2-3 spacing (µS)	Pulse Start(S)	Detection (1:yes; 0:no)
0	3	6	65	1968	1952	0.162405	1
1	2	6	80.8	1798		0.932022	
2	2	6	68.1	1626		1.717298	
3	3	6	55.1	1447	1834	2.507376	
4	2	6	92.1	1398		3.260123	
5	1	6	95.4			3.632529	
6	2	6	54.6	1885		4.315843	
7	1	6	74.4			5.279543	
8	2	6	90.6	1858		5.98113	
9	1	6	84.6			6.578213	
10	2	6	88.2	1591		6.822616	
11	2	6	76.2	1881		7.819806	
12	2	6	86.6	1887		8.203216	
13	1	6	93.4			9.026948	
14	2	6	77.9	1026		9.337802	
15	3	6	70.1	1934	1770	10.029432	
16	2	6	92	1808		11.21825	
17	3	6	96.3	1793	1880	11.921783	

Bin5 Statistics 14

Trial #	Pulse	Chirp (MHz)	Pulse Width (µS)	Pulse 1-2 spacing (µS)	Pulse 2-3 spacing (µS)	Pulse Start(S)	Detection (1:yes; 0:no)
0	3	10	75.8	1145	1580	0.350008	1
1	2	10	92.4	1441		1.262429	
2	2	10	60.1	1281		1.938378	
3	3	10	68	1677	1281	3.245119	
4	1	10	76.9			3.78001	
5	2	10	65.4	1997		5.081901	
6	1	10	95.5			5.839518	
7	2	10	60.9	1186		6.615002	
8	2	10	92.1	1676		7.642256	
9	2	10	84.6	1661		9.137286	
10	2	10	79.8	1395		9.924923	
11	1	10	65.6			10.520573	
12	2	10	74.5	1262		11.20649	

Bin5 Statistics 15

Trial #	Pulse	Chirp (MHz)	Pulse Width (µS)	Pulse 1-2 spacing (µS)	Pulse 2-3 spacing (µS)	Pulse Start(S)	Detection (1:yes; 0:no)
0	3	19	65	1967	1443	0.632446	0
1	2	19	91.5	1015		1.668627	
2	2	19	83	1638		2.79652	
3	3	19	66.5	1302	1981	3.444488	
4	1	19	52.4			4.384721	
5	2	19	51.9	1251		5.646772	
6	2	19	63.1	1727		6.495009	
7	1	19	84.5			7.397914	
8	2	19	75.8	1848		8.418282	
9	2	19	84.8	1280		9.165104	
10	2	19	58.6	1672		10.54076	
11	1	19	53.6			11.047451	

Bin5 Statistics 16

Trial #	Pulse	Chirp (MHz)	Pulse Width (µS)	Pulse 1-2 spacing (µS)	Pulse 2-3 spacing (µS)	Pulse Start(S)	Detection (1:yes; 0:no)
0	1	7	65.8			0.47011	1
1	1	7	73.5			0.722127	
2	3	7	51.8	1369	1681	1.295506	
3	2	7	66.6	1787		2.22944	
4	2	7	66.2	1566		2.901823	
5	2	7	99.9	1167		3.360772	
6	1	7	59.9			4.03082	
7	2	7	85.6	1909		4.467087	
8	3	7	71.5	1758	1589	5.482798	
9	2	7	52	1122		6.203974	
10	3	7	72.2	1292	1054	6.369733	
11	3	7	62	1222	1199	6.950842	
12	1	7	62.1			7.898383	
13	2	7	57.2	1619		8.678166	
14	2	7	89.9	1963		9.232068	
15	3	7	86.5	1942	1052	9.666942	
16	3	7	80.7	1410	1606	10.400911	
17	1	7	61.4			11.240516	
18	3	7	60	1243	1294	11.663118	

Bin5 Statistics 17

Trial #	Pulse	Chirp (MHz)	Pulse Width (µS)	Pulse 1-2 spacing (uS)	Pulse 2-3 spacing (uS)	Pulse Start(S)	Detection (1:yes; 0:no)
0	3	12	69.3	1045	1070	0.498792	1
1	2	12	62.1	1167		1.14593	
2	2	12	70.8	1884		2.267606	
3	2	12	94.5	1423		2.848824	
4	1	12	58.9			3.856149	
5	2	12	94.5	1570		4.614622	
6	2	12	65.6	1882		5.078059	
7	2	12	73.6	1797		6.109005	
8	3	12	90.9	1503	1368	7.132856	
9	1	12	59.1			7.742287	
10	2	12	90.5	1034		8.351592	
11	2	12	86.4	1023		9.105664	
12	3	12	52.5	1077	1933	10.255611	
13	2	12	85.9	1594		10.578695	
14	2	12	95.9	1309		11.873811	

Bin5 Statistics 18

Trial #	Pulse	Chirp (MHz)	Pulse Width (µS)	Pulse 1-2 spacing (uS)	Pulse 2-3 spacing (uS)	Pulse Start(S)	Detection (1:yes; 0:no)
0	2	12	86.6	1036		0.715711	1
1	2	12	79.1	1208		2.469587	
2	1	12	74			3.435369	
3	3	12	95.8	1210	1436	5.063189	
4	2	12	75.1	1165		7.108327	
5	3	12	92.4	1947	1924	7.504546	
6	1	12	97.8			9.37943	
7	3	12	84.9	1885	1822	11.491691	

Bin5 Statistics 19

Trial #	Pulse	Chirp (MHz)	Pulse Width (µS)	Pulse 1-2 spacing (µS)	Pulse 2-3 spacing (µS)	Pulse Start(S)	Detection (1:yes; 0:no)
0	2	12	98.7	1269		0.278814	1
1	2	12	59.9	1127		2.234666	
2	2	12	92.7	1229		2.458318	
3	1	12	68.1			4.544576	
4	2	12	59.8	1016		5.943695	
5	1	12	69			6.049525	
6	1	12	94			7.868605	
7	3	12	62.4	1231	1105	8.892435	
8	3	12	80.5	1265	1087	9.869378	
9	2	12	51.4	1813		10.903316	

Bin5 Statistics 20

Trial #	Pulse	Chirp (MHz)	Pulse Width (µS)	Pulse 1-2 spacing (µS)	Pulse 2-3 spacing (µS)	Pulse Start(S)	Detection (1:yes; 0:no)
0	3	10	84.4	1590	1654	0.859041	1
1	3	10	65	1778	1822	1.591519	
2	2	10	50.5	1750		2.989761	
3	3	10	71	1041	1016	3.908544	
4	3	10	95.5	1032	1393	5.353633	
5	2	10	73.5	1772		6.005129	
6	2	10	78.6	1412		7.528714	
7	3	10	77.6	1741	1332	8.026264	
8	1	10	59.8			8.845792	
9	2	10	61.4	1204		10.058606	
10	2	10	86.7	1253		11.367626	

Bin5 Statistics 21

Trial #	Pulse	Chirp (MHz)	Pulse Width (µS)	Pulse 1-2 spacing (µS)	Pulse 2-3 spacing (µS)	Pulse Start(S)	Detection (1:yes; 0:no)
0	2	8	90	1080		0.219576	1
1	1	8	69.4			1.424371	
2	2	8	91.2	1830		3.946258	
3	2	8	76.3	1911		4.122283	
4	3	8	58.7	1765	1644	6.098028	
5	2	8	51.1	1349		7.27049	
6	2	8	72.7	1128		8.089129	
7	3	8	57.3	1928	1257	9.80901	
8	2	8	55.1	1379		11.589447	

Bin5 Statistics 22

Trial #	Pulse	Chirp (MHz)	Pulse Width (µS)	Pulse 1-2 spacing (µS)	Pulse 2-3 spacing (µS)	Pulse Start(S)	Detection (1:yes; 0:no)
0	3	16	89.8	1130	1160	0.894243	1
1	2	16	53.1	1925		2.52515	
2	2	16	85.6	1058		3.604005	
3	2	16	77.8	1879		4.962202	
4	3	16	90.2	1484	1064	6.508422	
5	3	16	66.6	1300	1922	7.662156	
6	2	16	84.1	1842		8.420156	
7	2	16	89.2	1151		10.606644	
8	2	16	99.5	1452		11.070532	

Bin5 Statistics 23

Trial #	Pulse	Chirp (MHz)	Pulse Width (µS)	Pulse 1-2 spacing (µS)	Pulse 2-3 spacing (µS)	Pulse Start(S)	Detection (1:yes; 0:no)
0	3	7	66.4	1636	1225	1.179689	1
1	3	7	70.5	1783	1472	2.688724	
2	3	7	52.4	1267	1741	3.943932	
3	1	7	67			5.062088	
4	1	7	63.4			7.279417	
5	2	7	70.4	1304		7.923061	
6	2	7	74.1	1915		10.395424	
7	2	7	97.1	1493		11.556568	

Bin5 Statistics 24

Trial #	Pulse	Chirp (MHz)	Pulse Width (µS)	Pulse 1-2 spacing (uS)	Pulse 2-3 spacing (uS)	Pulse Start(S)	Detection (1:yes; 0:no)
0	2	11	99	1778		0.228946	1
1	1	11	58.3			2.945744	
2	1	11	50.5			3.929173	
3	1	11	54.6			5.464777	
4	1	11	95.6			6.679014	
5	1	11	76.4			8.597275	
6	3	11	64.1	1374	1783	9.875092	
7	2	11	69	1063		10.81034	

Bin5 Statistics 25

Trial #	Pulse	Chirp (MHz)	Pulse Width (µS)	Pulse 1-2 spacing (uS)	Pulse 2-3 spacing (uS)	Pulse Start(S)	Detection (1:yes; 0:no)
0	1	9	98.7			0.364674	1
1	3	9	77.5	1096	1309	1.014199	
2	2	9	59.3	1163		1.526864	
3	1	9	98.8			2.39493	
4	2	9	68.8	1049		2.929676	
5	2	9	90.1	1883		3.758766	
6	3	9	74.5	1579	1772	3.967606	
7	3	9	74.7	1022	1442	4.964585	
8	1	9	86.1			5.575236	
9	2	9	95.9	1059		6.290246	
10	2	9	93	1152		6.685633	
11	1	9	85.4			7.046287	
12	2	9	89.5	1453		7.742894	
13	3	9	72	1134	1616	8.673863	
14	1	9	57.6			8.868202	
15	1	9	54.6			10.010829	
16	2	9	98.5	1450		10.432474	
17	3	9	77.9	1069	1258	10.829957	
18	2	9	65.3	1943		11.487268	

Bin5 Statistics 26

Trial #	Pulse	Chirp (MHz)	Pulse Width (µS)	Pulse 1-2 spacing (µS)	Pulse 2-3 spacing (µS)	Pulse Start(S)	Detection (1:yes; 0:no)
0	1	14	55.8			0.07312	1
1	2	14	73.2	1275		1.401365	
2	2	14	72	1140		1.896865	
3	2	14	79.9	1741		3.084644	
4	3	14	93.4	1537	1705	3.500013	
5	3	14	54.4	1843	1898	4.585633	
6	2	14	58.6	1507		5.394017	
7	1	14	78.5			5.631738	
8	3	14	78.8	1892	1858	6.888577	
9	2	14	59.9	2000		7.835748	
10	3	14	68.5	1082	1022	8.147344	
11	2	14	70.8	1410		9.268615	
12	2	14	89	1583		10.274225	
13	2	14	79.1	1122		10.522848	
14	3	14	57.2	1400	1439	11.680189	

Bin5 Statistics 27

Trial #	Pulse	Chirp (MHz)	Pulse Width (µS)	Pulse 1-2 spacing (µS)	Pulse 2-3 spacing (µS)	Pulse Start(S)	Detection (1:yes; 0:no)
0	2	8	73.1	1147		0.008312	1
1	1	8	73.8			1.081998	
2	2	8	83.2	1956		2.140993	
3	1	8	59.6			3.290625	
4	2	8	57.1	1740		4.068529	
5	3	8	61.3	1022	1060	4.677237	
6	2	8	74.8	1011		5.981297	
7	3	8	79.3	1780	1636	7.196875	
8	1	8	79.1			7.829168	
9	3	8	63.9	1077	1476	9.205323	
10	2	8	58.9	1574		10.06971	
11	2	8	67.8	1825		10.236353	
12	2	8	57.8	1986		11.831328	

Bin5 Statistics 28

Trial #	Pulse	Chirp (MHz)	Pulse Width (uS)	Pulse 1-2 spacing (uS)	Pulse 2-3 spacing (uS)	Pulse Start(S)	Detection (1:yes; 0:no)
0	1	18	68.1			0.170803	1
1	3	18	83.5	1361	1204	1.275708	
2	2	18	55.9	1168		1.886179	
3	3	18	92.8	1586	1145	3.162409	
4	1	18	82.7			3.924888	
5	3	18	95.3	1256	1403	4.111799	
6	2	18	76.3	1809		5.175303	
7	2	18	85.6	1342		5.995661	
8	2	18	96.3	1613		6.753312	
9	2	18	72.2	1301		7.840424	
10	3	18	69.1	1419	1735	8.165397	
11	2	18	50.3	1807		8.808624	
12	2	18	96.5	1322		10.166516	
13	3	18	86.7	1445	1232	10.965363	
14	2	18	58.1	1279		11.812792	

Bin5 Statistics 29

Trial #	Pulse	Chirp (MHz)	Pulse Width (uS)	Pulse 1-2 spacing (uS)	Pulse 2-3 spacing (uS)	Pulse Start(S)	Detection (1:yes; 0:no)
0	1	14	87.3			0.765877	1
1	2	14	62.4	1333		1.988387	
2	2	14	88.6	1158		3.661212	
3	2	14	54.2	1562		5.801541	
4	1	14	96.9			6.327082	
5	1	14	89.4			7.730806	
6	3	14	83.7	1464	1122	10.090498	
7	2	14	77.2	1106		10.755569	

Bin5 Statistics 30

Trial #	Pulse	Chirp (MHz)	Pulse Width (µS)	Pulse 1-2 spacing (µS)	Pulse 2-3 spacing (µS)	Pulse Start(S)	Detection (1:yes; 0:no)
0	2	14	99.6	1789		0.642225	1
1	1	14	61.8			1.315461	
2	2	14	98.3	1464		1.789114	
3	2	14	50.3	1096		2.967222	
4	1	14	97.9			3.970659	
5	2	14	63.2	1059		4.061968	
6	2	14	71.1	1625		5.069686	
7	2	14	97.4	1748		5.618991	
8	2	14	51.9	1112		6.419372	
9	1	14	87.3			7.486321	
10	3	14	65.5	1414	1471	8.498406	
11	2	14	92.2	1348		9.186503	
12	3	14	71.9	1314	1956	10.299709	
13	3	14	80.2	1709	1905	10.525278	
14	2	14	97.6	1640		11.258389	

Table-6 Radar Type 6 Statistical Performance

Trial #	Fc (MHz)	Pulse /Burst	Pulse Width (µS)	PRI (µs)	Detection (1:yes; 0:no)	Hopping Sequence
1	5250	9	1	333	1	5423.0, 5606.0, 5341.0, 5591.0, 5634.0, 5520.0, 5664.0, 5414.0, 5329.0, 5714.0, 5356.0, 5721.0, 5514.0, 5692.0, 5281.0, 5555.0, 5251.0, 5694.0, 5402.0, 5386.0, 5436.0, 5312.0, 5544.0, 5412.0, 5335.0, 5473.0, 5461.0, 5522.0, 5629.0, 5647.0, 5388.0, 5672.0, 5272.0, 5645.0, 5566.0, 5328.0, 5563.0, 5681.0, 5342.0, 5561.0, 5398.0, 5447.0, 5483.0, 5401.0, 5439.0, 5595.0, 5449.0, 5541.0, 5609.0, 5588.0, 5316.0, 5252.0, 5384.0, 5601.0, 5580.0, 5655.0, 5479.0, 5592.0, 5265.0, 5559.0, 5374.0, 5297.0, 5428.0, 5371.0, 5670.0, 5701.0, 5264.0, 5500.0, 5353.0, 5303.0, 5657.0, 5309.0, 5505.0, 5464.0, 5410.0, 5663.0, 5642.0, 5525.0, 5702.0, 5636.0, 5578.0, 5646.0, 5643.0, 5564.0, 5472.0, 5440.0, 5279.0, 5372.0, 5711.0, 5361.0, 5261.0, 5622.0, 5597.0, 5495.0, 5477.0, 5427.0, 5381.0, 5408.0, 5712.0, 5510.0 (number of hits: 8)
2	5250	9	1	333	1	5556.0, 5321.0, 5297.0, 5435.0, 5693.0, 5450.0, 5543.0, 5465.0, 5289.0, 5430.0, 5578.0, 5641.0, 5673.0, 5318.0, 5449.0, 5443.0, 5458.0, 5644.0, 5655.0, 5620.0, 5299.0, 5568.0, 5315.0, 5418.0, 5383.0, 5582.0, 5506.0, 5512.0, 5477.0, 5682.0, 5622.0, 5608.0, 5633.0, 5328.0, 5613.0, 5562.0, 5448.0, 5336.0, 5394.0, 5308.0, 5399.0, 5255.0, 5695.0, 5599.0, 5400.0, 5414.0, 5345.0, 5708.0, 5646.0, 5555.0, 5601.0, 5348.0, 5325.0, 5528.0, 5631.0, 5302.0, 5494.0, 5619.0, 5615.0, 5311.0, 5451.0, 5320.0, 5335.0, 5523.0, 5254.0, 5575.0, 5679.0, 5397.0, 5488.0, 5338.0, 5577.0, 5636.0, 5359.0, 5368.0, 5573.0, 5677.0, 5406.0, 5288.0, 5718.0, 5719.0, 5471.0, 5588.0, 5495.0, 5614.0, 5579.0, 5713.0, 5645.0, 5700.0, 5340.0, 5253.0, 5490.0, 5538.0, 5351.0, 5618.0, 5293.0, 5374.0, 5324.0, 5303.0, 5457.0, 5640.0 (number of hits: 5)
3	5250	9	1	333	1	5647.0, 5508.0, 5552.0, 5554.0, 5486.0, 5265.0, 5442.0, 5676.0, 5294.0, 5509.0, 5530.0, 5428.0, 5314.0, 5325.0, 5413.0, 5603.0, 5697.0, 5382.0, 5439.0, 5451.0, 5376.0, 5285.0, 5274.0, 5662.0, 5292.0, 5372.0, 5416.0, 5546.0, 5487.0, 5474.0, 5492.0, 5571.0, 5585.0, 5623.0, 5484.0, 5465.0, 5488.0, 5419.0, 5703.0, 5569.0, 5620.0, 5327.0, 5433.0, 5326.0, 5260.0, 5523.0, 5291.0, 5371.0, 5374.0, 5319.0, 5257.0, 5564.0, 5589.0, 5270.0, 5628.0, 5677.0, 5345.0, 5630.0, 5587.0, 5496.0, 5403.0, 5447.0, 5563.0, 5606.0, 5636.0,

						5635.0, 5595.0, 5562.0, 5639.0, 5657.0, 5275.0, 5499.0, 5720.0, 5539.0, 5714.0, 5286.0, 5537.0, 5674.0, 5650.0, 5517.0, 5667.0, 5602.0, 5482.0, 5527.0, 5312.0, 5328.0, 5409.0, 5614.0, 5722.0, 5300.0, 5632.0, 5352.0, 5329.0, 5651.0, 5625.0, 5408.0, 5596.0, 5547.0, 5343.0, 5684.0 (number of hits: 8)
4	5250	9	1	333	1	5498.0, 5506.0, 5642.0, 5681.0, 5434.0, 5531.0, 5452.0, 5362.0, 5578.0, 5618.0, 5667.0, 5723.0, 5513.0, 5542.0, 5516.0, 5711.0, 5495.0, 5379.0, 5445.0, 5355.0, 5705.0, 5460.0, 5403.0, 5557.0, 5560.0, 5308.0, 5553.0, 5291.0, 5470.0, 5421.0, 5682.0, 5270.0, 5703.0, 5722.0, 5305.0, 5629.0, 5320.0, 5255.0, 5694.0, 5699.0, 5502.0, 5412.0, 5611.0, 5537.0, 5512.0, 5464.0, 5451.0, 5327.0, 5296.0, 5278.0, 5507.0, 5659.0, 5505.0, 5346.0, 5697.0, 5284.0, 5619.0, 5640.0, 5683.0, 5395.0, 5610.0, 5446.0, 5567.0, 5672.0, 5634.0, 5289.0, 5679.0, 5330.0, 5684.0, 5484.0, 5713.0, 5301.0, 5644.0, 5454.0, 5593.0, 5607.0, 5351.0, 5402.0, 5680.0, 5407.0, 5385.0, 5545.0, 5633.0, 5447.0, 5419.0, 5277.0, 5297.0, 5550.0, 5271.0, 5539.0, 5483.0, 5337.0, 5686.0, 5514.0, 5602.0, 5463.0, 5455.0, 5314.0, 5708.0, 5370.0 (number of hits: 7)
5	5250	9	1	333	1	5357.0, 5632.0, 5492.0, 5701.0, 5265.0, 5395.0, 5335.0, 5511.0, 5607.0, 5617.0, 5662.0, 5434.0, 5559.0, 5483.0, 5610.0, 5631.0, 5486.0, 5536.0, 5535.0, 5527.0, 5446.0, 5267.0, 5378.0, 5534.0, 5570.0, 5622.0, 5353.0, 5677.0, 5598.0, 5549.0, 5422.0, 5616.0, 5684.0, 5627.0, 5670.0, 5473.0, 5643.0, 5270.0, 5553.0, 5336.0, 5678.0, 5681.0, 5436.0, 5626.0, 5268.0, 5564.0, 5687.0, 5379.0, 5671.0, 5307.0, 5458.0, 5506.0, 5568.0, 5664.0, 5311.0, 5519.0, 5619.0, 5593.0, 5569.0, 5614.0, 5385.0, 5330.0, 5256.0, 5522.0, 5264.0, 5663.0, 5596.0, 5530.0, 5668.0, 5351.0, 5656.0, 5453.0, 5471.0, 5588.0, 5679.0, 5472.0, 5498.0, 5532.0, 5327.0, 5281.0, 5575.0, 5539.0, 5507.0, 5263.0, 5706.0, 5277.0, 5310.0, 5314.0, 5599.0, 5685.0, 5302.0, 5485.0, 5520.0, 5572.0, 5711.0, 5279.0, 5301.0, 5517.0, 5690.0, 5348.0 (number of hits: 10)
6	5250	9	1	333	1	5255.0, 5376.0, 5500.0, 5450.0, 5396.0, 5354.0, 5576.0, 5648.0, 5594.0, 5264.0, 5656.0, 5673.0, 5258.0, 5252.0, 5326.0, 5717.0, 5706.0, 5254.0, 5337.0, 5511.0, 5400.0, 5568.0, 5456.0, 5714.0, 5467.0, 5633.0, 5329.0, 5256.0, 5650.0, 5425.0, 5700.0, 5649.0, 5321.0, 5546.0, 5265.0, 5572.0, 5394.0, 5512.0, 5464.0, 5692.0, 5618.0, 5305.0, 5346.0, 5547.0, 5291.0, 5251.0, 5470.0, 5599.0, 5363.0, 5628.0, 5447.0, 5558.0, 5569.0, 5304.0, 5575.0,

						5657.0, 5403.0, 5645.0, 5545.0, 5684.0, 5712.0, 5308.0, 5368.0, 5313.0, 5598.0, 5250.0, 5637.0, 5603.0, 5423.0, 5455.0, 5299.0, 5270.0, 5622.0, 5556.0, 5510.0, 5600.0, 5462.0, 5451.0, 5581.0, 5589.0, 5516.0, 5364.0, 5370.0, 5574.0, 5664.0, 5707.0, 5586.0, 5661.0, 5397.0, 5670.0, 5704.0, 5665.0, 5701.0, 5292.0, 5374.0, 5441.0, 5342.0, 5654.0, 5503.0, 5549.0 (number of hits: 10)
7	5250	9	1	333	1	5350.0, 5352.0, 5624.0, 5411.0, 5553.0, 5681.0, 5492.0, 5341.0, 5605.0, 5509.0, 5466.0, 5565.0, 5305.0, 5325.0, 5545.0, 5600.0, 5304.0, 5403.0, 5299.0, 5628.0, 5668.0, 5703.0, 5501.0, 5261.0, 5360.0, 5529.0, 5536.0, 5461.0, 5268.0, 5723.0, 5406.0, 5314.0, 5531.0, 5464.0, 5602.0, 5443.0, 5715.0, 5512.0, 5427.0, 5697.0, 5356.0, 5337.0, 5370.0, 5332.0, 5714.0, 5710.0, 5717.0, 5542.0, 5689.0, 5659.0, 5422.0, 5431.0, 5663.0, 5378.0, 5647.0, 5667.0, 5584.0, 5587.0, 5254.0, 5425.0, 5650.0, 5502.0, 5625.0, 5683.0, 5547.0, 5559.0, 5390.0, 5695.0, 5457.0, 5357.0, 5574.0, 5563.0, 5555.0, 5271.0, 5367.0, 5506.0, 5267.0, 5358.0, 5661.0, 5329.0, 5556.0, 5551.0, 5371.0, 5670.0, 5609.0, 5417.0, 5368.0, 5608.0, 5263.0, 5657.0, 5462.0, 5648.0, 5532.0, 5373.0, 5397.0, 5477.0, 5535.0, 5517.0, 5554.0, 5426.0 (number of hits: 6)
8	5250	9	1	333	1	5287.0, 5481.0, 5316.0, 5467.0, 5452.0, 5315.0, 5531.0, 5473.0, 5524.0, 5440.0, 5600.0, 5602.0, 5629.0, 5596.0, 5636.0, 5331.0, 5361.0, 5268.0, 5335.0, 5394.0, 5556.0, 5401.0, 5519.0, 5511.0, 5259.0, 5675.0, 5603.0, 5450.0, 5625.0, 5328.0, 5694.0, 5269.0, 5649.0, 5618.0, 5421.0, 5712.0, 5533.0, 5722.0, 5387.0, 5458.0, 5518.0, 5286.0, 5445.0, 5428.0, 5382.0, 5279.0, 5573.0, 5379.0, 5686.0, 5480.0, 5719.0, 5693.0, 5642.0, 5470.0, 5707.0, 5696.0, 5575.0, 5594.0, 5325.0, 5375.0, 5284.0, 5654.0, 5432.0, 5417.0, 5378.0, 5293.0, 5273.0, 5412.0, 5709.0, 5448.0, 5299.0, 5490.0, 5348.0, 5351.0, 5631.0, 5405.0, 5555.0, 5339.0, 5517.0, 5376.0, 5430.0, 5285.0, 5549.0, 5486.0, 5353.0, 5396.0, 5607.0, 5307.0, 5718.0, 5597.0, 5365.0, 5504.0, 5477.0, 5487.0, 5289.0, 5282.0, 5425.0, 5393.0, 5444.0, 5352.0 (number of hits: 11)
9	5250	9	1	333	1	5385.0, 5620.0, 5563.0, 5253.0, 5347.0, 5662.0, 5659.0, 5656.0, 5470.0, 5605.0, 5567.0, 5635.0, 5647.0, 5633.0, 5556.0, 5527.0, 5722.0, 5456.0, 5591.0, 5256.0, 5440.0, 5378.0, 5513.0, 5436.0, 5669.0, 5479.0, 5607.0, 5495.0, 5716.0, 5600.0, 5355.0, 5471.0, 5346.0, 5638.0, 5269.0, 5555.0, 5294.0, 5441.0, 5420.0, 5670.0, 5365.0, 5721.0, 5616.0, 5293.0, 5270.0,

						5340.0, 5697.0, 5390.0, 5435.0, 5718.0, 5405.0, 5506.0, 5418.0, 5708.0, 5549.0, 5275.0, 5548.0, 5252.0, 5312.0, 5505.0, 5424.0, 5476.0, 5410.0, 5283.0, 5610.0, 5644.0, 5541.0, 5665.0, 5457.0, 5521.0, 5646.0, 5684.0, 5710.0, 5568.0, 5719.0, 5386.0, 5680.0, 5494.0, 5421.0, 5357.0, 5542.0, 5341.0, 5484.0, 5274.0, 5709.0, 5406.0, 5690.0, 5693.0, 5339.0, 5570.0, 5687.0, 5650.0, 5491.0, 5698.0, 5569.0, 5351.0, 5643.0, 5366.0, 5639.0, 5653.0 (number of hits: 8)
10	5250	9	1	333	1	5594.0, 5563.0, 5700.0, 5672.0, 5577.0, 5621.0, 5526.0, 5452.0, 5601.0, 5253.0, 5682.0, 5301.0, 5448.0, 5283.0, 5441.0, 5490.0, 5635.0, 5395.0, 5488.0, 5581.0, 5445.0, 5469.0, 5390.0, 5610.0, 5292.0, 5683.0, 5680.0, 5470.0, 5393.0, 5536.0, 5262.0, 5307.0, 5549.0, 5363.0, 5608.0, 5252.0, 5318.0, 5367.0, 5364.0, 5349.0, 5561.0, 5394.0, 5668.0, 5463.0, 5545.0, 5538.0, 5436.0, 5462.0, 5593.0, 5385.0, 5616.0, 5389.0, 5659.0, 5664.0, 5410.0, 5578.0, 5713.0, 5398.0, 5603.0, 5540.0, 5657.0, 5552.0, 5313.0, 5281.0, 5414.0, 5328.0, 5525.0, 5408.0, 5507.0, 5519.0, 5702.0, 5483.0, 5430.0, 5342.0, 5546.0, 5484.0, 5326.0, 5353.0, 5489.0, 5444.0, 5710.0, 5548.0, 5598.0, 5359.0, 5681.0, 5460.0, 5254.0, 5613.0, 5405.0, 5709.0, 5716.0, 5534.0, 5666.0, 5298.0, 5413.0, 5340.0, 5265.0, 5487.0, 5376.0, 5595.0 (number of hits: 7)
11	5250	9	1	333	1	5374.0, 5543.0, 5373.0, 5421.0, 5490.0, 5558.0, 5333.0, 5420.0, 5581.0, 5457.0, 5499.0, 5459.0, 5695.0, 5414.0, 5607.0, 5454.0, 5376.0, 5584.0, 5527.0, 5381.0, 5462.0, 5535.0, 5526.0, 5597.0, 5316.0, 5419.0, 5512.0, 5486.0, 5428.0, 5315.0, 5579.0, 5629.0, 5634.0, 5337.0, 5252.0, 5517.0, 5422.0, 5652.0, 5541.0, 5278.0, 5436.0, 5667.0, 5282.0, 5708.0, 5259.0, 5320.0, 5443.0, 5350.0, 5673.0, 5362.0, 5690.0, 5577.0, 5261.0, 5599.0, 5408.0, 5413.0, 5338.0, 5327.0, 5404.0, 5588.0, 5649.0, 5563.0, 5341.0, 5549.0, 5699.0, 5352.0, 5572.0, 5664.0, 5449.0, 5686.0, 5425.0, 5441.0, 5349.0, 5412.0, 5724.0, 5522.0, 5453.0, 5405.0, 5557.0, 5260.0, 5276.0, 5585.0, 5547.0, 5635.0, 5654.0, 5360.0, 5554.0, 5363.0, 5596.0, 5720.0, 5268.0, 5426.0, 5702.0, 5633.0, 5293.0, 5255.0, 5294.0, 5642.0, 5696.0, 5319.0 (number of hits: 9)
12	5290	9	1	333	1	5477.0, 5274.0, 5721.0, 5469.0, 5485.0, 5637.0, 5602.0, 5355.0, 5672.0, 5350.0, 5380.0, 5283.0, 5431.0, 5475.0, 5598.0, 5534.0, 5287.0, 5595.0, 5410.0, 5421.0, 5625.0, 5580.0, 5332.0, 5586.0, 5269.0, 5461.0, 5463.0, 5667.0, 5500.0, 5417.0, 5665.0, 5365.0, 5474.0, 5434.0, 5255.0,

						5432.0, 5664.0, 5537.0, 5327.0, 5651.0, 5508.0, 5352.0, 5414.0, 5705.0, 5696.0, 5695.0, 5476.0, 5568.0, 5378.0, 5559.0, 5560.0, 5702.0, 5267.0, 5278.0, 5362.0, 5689.0, 5286.0, 5577.0, 5404.0, 5650.0, 5608.0, 5315.0, 5266.0, 5613.0, 5541.0, 5505.0, 5328.0, 5517.0, 5660.0, 5470.0, 5629.0, 5492.0, 5617.0, 5715.0, 5308.0, 5539.0, 5275.0, 5605.0, 5655.0, 5556.0, 5628.0, 5671.0, 5710.0, 5606.0, 5697.0, 5348.0, 5604.0, 5658.0, 5262.0, 5459.0, 5313.0, 5397.0, 5281.0, 5614.0, 5406.0, 5490.0, 5251.0, 5562.0, 5478.0, 5591.0 (number of hits: 18)
13	5290	9	1	333	1	5401.0, 5645.0, 5440.0, 5351.0, 5417.0, 5314.0, 5336.0, 5323.0, 5428.0, 5544.0, 5524.0, 5341.0, 5605.0, 5430.0, 5416.0, 5286.0, 5687.0, 5498.0, 5356.0, 5380.0, 5705.0, 5651.0, 5302.0, 5597.0, 5476.0, 5371.0, 5692.0, 5532.0, 5714.0, 5385.0, 5679.0, 5690.0, 5397.0, 5486.0, 5465.0, 5671.0, 5695.0, 5562.0, 5310.0, 5639.0, 5402.0, 5586.0, 5346.0, 5268.0, 5583.0, 5612.0, 5370.0, 5630.0, 5548.0, 5607.0, 5598.0, 5415.0, 5517.0, 5574.0, 5553.0, 5596.0, 5473.0, 5437.0, 5455.0, 5720.0, 5316.0, 5704.0, 5475.0, 5506.0, 5576.0, 5361.0, 5642.0, 5261.0, 5545.0, 5467.0, 5646.0, 5425.0, 5622.0, 5327.0, 5591.0, 5384.0, 5354.0, 5454.0, 5636.0, 5526.0, 5558.0, 5716.0, 5584.0, 5683.0, 5510.0, 5570.0, 5254.0, 5537.0, 5298.0, 5329.0, 5481.0, 5387.0, 5595.0, 5669.0, 5435.0, 5611.0, 5712.0, 5383.0, 5263.0, 5579.0 (number of hits: 13)
14	5290	9	1	333	1	5332.0, 5586.0, 5284.0, 5566.0, 5599.0, 5546.0, 5445.0, 5697.0, 5384.0, 5348.0, 5547.0, 5341.0, 5271.0, 5572.0, 5682.0, 5608.0, 5602.0, 5335.0, 5692.0, 5281.0, 5378.0, 5653.0, 5257.0, 5394.0, 5263.0, 5501.0, 5296.0, 5552.0, 5268.0, 5429.0, 5466.0, 5464.0, 5681.0, 5361.0, 5514.0, 5663.0, 5285.0, 5559.0, 5525.0, 5370.0, 5679.0, 5411.0, 5610.0, 5496.0, 5264.0, 5669.0, 5442.0, 5640.0, 5380.0, 5320.0, 5326.0, 5256.0, 5711.0, 5646.0, 5358.0, 5472.0, 5321.0, 5522.0, 5444.0, 5650.0, 5480.0, 5519.0, 5570.0, 5345.0, 5269.0, 5624.0, 5303.0, 5343.0, 5550.0, 5543.0, 5415.0, 5676.0, 5635.0, 5689.0, 5685.0, 5656.0, 5408.0, 5350.0, 5723.0, 5568.0, 5482.0, 5592.0, 5569.0, 5272.0, 5397.0, 5478.0, 5339.0, 5259.0, 5596.0, 5532.0, 5706.0, 5637.0, 5277.0, 5607.0, 5353.0, 5468.0, 5250.0, 5396.0, 5516.0, 5266.0 (number of hits: 20)
15	5290	9	1	333	1	5321.0, 5702.0, 5497.0, 5608.0, 5354.0, 5389.0, 5604.0, 5329.0, 5625.0, 5447.0, 5398.0, 5665.0, 5342.0, 5706.0, 5415.0, 5311.0, 5299.0, 5561.0, 5679.0, 5449.0, 5615.0, 5263.0, 5332.0, 5521.0, 5680.0,

						5446.0, 5637.0, 5371.0, 5607.0, 5411.0, 5491.0, 5569.0, 5600.0, 5544.0, 5718.0, 5589.0, 5642.0, 5517.0, 5452.0, 5587.0, 5487.0, 5306.0, 5426.0, 5352.0, 5450.0, 5538.0, 5331.0, 5434.0, 5553.0, 5526.0, 5611.0, 5368.0, 5614.0, 5714.0, 5704.0, 5367.0, 5649.0, 5632.0, 5341.0, 5383.0, 5382.0, 5629.0, 5296.0, 5292.0, 5406.0, 5314.0, 5418.0, 5335.0, 5523.0, 5482.0, 5686.0, 5641.0, 5262.0, 5715.0, 5498.0, 5537.0, 5534.0, 5397.0, 5308.0, 5424.0, 5596.0, 5326.0, 5602.0, 5581.0, 5372.0, 5640.0, 5448.0, 5404.0, 5475.0, 5646.0, 5638.0, 5695.0, 5660.0, 5344.0, 5293.0, 5601.0, 5598.0, 5565.0, 5688.0, 5324.0 (number of hits: 14)
16	5290	9	1	333	1	5715.0, 5515.0, 5546.0, 5673.0, 5627.0, 5522.0, 5561.0, 5280.0, 5667.0, 5599.0, 5520.0, 5295.0, 5589.0, 5663.0, 5684.0, 5323.0, 5587.0, 5580.0, 5537.0, 5312.0, 5454.0, 5439.0, 5463.0, 5400.0, 5626.0, 5319.0, 5592.0, 5596.0, 5381.0, 5318.0, 5482.0, 5543.0, 5298.0, 5345.0, 5687.0, 5432.0, 5328.0, 5488.0, 5380.0, 5445.0, 5347.0, 5437.0, 5704.0, 5490.0, 5620.0, 5438.0, 5302.0, 5647.0, 5625.0, 5496.0, 5325.0, 5326.0, 5270.0, 5296.0, 5532.0, 5371.0, 5563.0, 5554.0, 5316.0, 5685.0, 5717.0, 5507.0, 5376.0, 5672.0, 5484.0, 5690.0, 5322.0, 5643.0, 5578.0, 5392.0, 5506.0, 5303.0, 5409.0, 5305.0, 5351.0, 5300.0, 5378.0, 5680.0, 5492.0, 5686.0, 5549.0, 5346.0, 5594.0, 5545.0, 5705.0, 5337.0, 5361.0, 5500.0, 5313.0, 5585.0, 5372.0, 5321.0, 5660.0, 5420.0, 5607.0, 5268.0, 5368.0, 5544.0, 5277.0, 5394.0 (number of hits: 22)
17	5290	9	1	333	1	5368.0, 5494.0, 5708.0, 5343.0, 5411.0, 5261.0, 5410.0, 5255.0, 5466.0, 5280.0, 5358.0, 5618.0, 5347.0, 5455.0, 5568.0, 5268.0, 5551.0, 5485.0, 5544.0, 5498.0, 5334.0, 5684.0, 5658.0, 5426.0, 5710.0, 5318.0, 5652.0, 5668.0, 5402.0, 5490.0, 5326.0, 5548.0, 5654.0, 5309.0, 5317.0, 5495.0, 5646.0, 5392.0, 5271.0, 5634.0, 5549.0, 5587.0, 5597.0, 5645.0, 5680.0, 5330.0, 5312.0, 5322.0, 5514.0, 5440.0, 5662.0, 5567.0, 5686.0, 5301.0, 5379.0, 5461.0, 5441.0, 5559.0, 5666.0, 5561.0, 5491.0, 5305.0, 5589.0, 5480.0, 5670.0, 5362.0, 5458.0, 5713.0, 5579.0, 5324.0, 5650.0, 5282.0, 5516.0, 5596.0, 5526.0, 5609.0, 5594.0, 5306.0, 5683.0, 5463.0, 5706.0, 5720.0, 5690.0, 5453.0, 5447.0, 5503.0, 5472.0, 5606.0, 5573.0, 5393.0, 5335.0, 5419.0, 5356.0, 5608.0, 5388.0, 5413.0, 5625.0, 5384.0, 5401.0, 5253.0 (number of hits: 17)
18	5290	9	1	333	1	5318.0, 5394.0, 5575.0, 5634.0, 5450.0, 5255.0, 5612.0, 5294.0, 5407.0, 5502.0, 5622.0, 5616.0, 5627.0, 5658.0, 5322.0,

						5424.0, 5602.0, 5467.0, 5716.0, 5277.0, 5508.0, 5706.0, 5687.0, 5326.0, 5651.0, 5696.0, 5719.0, 5640.0, 5300.0, 5567.0, 5444.0, 5548.0, 5470.0, 5258.0, 5714.0, 5483.0, 5528.0, 5531.0, 5406.0, 5488.0, 5587.0, 5398.0, 5650.0, 5626.0, 5481.0, 5452.0, 5308.0, 5570.0, 5654.0, 5330.0, 5259.0, 5379.0, 5392.0, 5314.0, 5668.0, 5279.0, 5675.0, 5358.0, 5511.0, 5402.0, 5426.0, 5377.0, 5532.0, 5478.0, 5315.0, 5624.0, 5495.0, 5596.0, 5284.0, 5546.0, 5712.0, 5250.0, 5320.0, 5442.0, 5691.0, 5340.0, 5489.0, 5396.0, 5664.0, 5369.0, 5469.0, 5666.0, 5720.0, 5510.0, 5485.0, 5414.0, 5371.0, 5312.0, 5671.0, 5482.0, 5433.0, 5542.0, 5717.0, 5352.0, 5659.0, 5356.0, 5711.0, 5347.0, 5589.0, 5257.0 (number of hits: 18)
19	5290	9	1	333	0	0
20	5290	9	1	333	1	5559.0, 5660.0, 5516.0, 5578.0, 5435.0, 5293.0, 5468.0, 5512.0, 5466.0, 5473.0, 5517.0, 5542.0, 5412.0, 5597.0, 5599.0, 5574.0, 5620.0, 5566.0, 5391.0, 5577.0, 5605.0, 5436.0, 5609.0, 5430.0, 5433.0, 5296.0, 5272.0, 5582.0, 5719.0, 5402.0, 5601.0, 5331.0, 5498.0, 5447.0, 5657.0, 5694.0, 5325.0, 5595.0, 5496.0, 5428.0, 5713.0, 5644.0, 5682.0, 5632.0, 5648.0, 5589.0, 5273.0, 5659.0, 5717.0, 5352.0, 5581.0, 5617.0, 5583.0, 5440.0, 5639.0, 5286.0, 5528.0, 5522.0, 5683.0, 5253.0, 5515.0, 5378.0, 5407.0, 5691.0, 5299.0, 5557.0, 5405.0, 5266.0, 5695.0, 5679.0, 5513.0, 5495.0, 5491.0, 5372.0, 5655.0, 5661.0, 5287.0, 5390.0, 5425.0, 5723.0, 5414.0, 5621.0, 5654.0, 5263.0, 5537.0, 5684.0, 5671.0, 5563.0, 5714.0, 5282.0, 5497.0, 5328.0, 5292.0, 5323.0, 5385.0, 5366.0, 5345.0, 5538.0, 5530.0, 5404.0 (number of hits: 15)
21	5330	9	1	333	1	5619.0, 5563.0, 5587.0, 5319.0, 5484.0, 5311.0, 5291.0, 5441.0, 5573.0, 5344.0, 5309.0, 5584.0, 5456.0, 5596.0, 5698.0, 5562.0, 5264.0, 5626.0, 5284.0, 5391.0, 5713.0, 5670.0, 5597.0, 5682.0, 5334.0, 5360.0, 5273.0, 5397.0, 5709.0, 5669.0, 5312.0, 5633.0, 5304.0, 5715.0, 5252.0, 5580.0, 5428.0, 5274.0, 5684.0, 5691.0, 5265.0, 5646.0, 5299.0, 5708.0, 5317.0, 5672.0, 5401.0, 5534.0, 5494.0, 5371.0, 5432.0, 5374.0, 5365.0, 5545.0, 5438.0, 5322.0, 5257.0, 5539.0, 5594.0, 5657.0, 5442.0, 5288.0, 5687.0, 5308.0, 5618.0, 5558.0, 5328.0, 5431.0, 5366.0, 5297.0, 5368.0, 5680.0, 5678.0, 5664.0, 5622.0, 5477.0, 5434.0, 5671.0, 5427.0, 5667.0, 5253.0, 5683.0, 5400.0, 5617.0, 5611.0, 5389.0, 5465.0, 5642.0, 5668.0, 5414.0, 5506.0, 5393.0, 5604.0, 5421.0, 5373.0, 5315.0, 5378.0, 5321.0, 5600.0, 5356.0 (number of hits: 21)

22	5330	9	1	333	1	5598.0, 5412.0, 5585.0, 5663.0, 5479.0, 5641.0, 5350.0, 5515.0, 5714.0, 5421.0, 5347.0, 5669.0, 5528.0, 5339.0, 5384.0, 5560.0, 5463.0, 5538.0, 5581.0, 5685.0, 5279.0, 5419.0, 5554.0, 5460.0, 5531.0, 5675.0, 5545.0, 5561.0, 5723.0, 5626.0, 5690.0, 5668.0, 5351.0, 5258.0, 5628.0, 5633.0, 5537.0, 5684.0, 5379.0, 5472.0, 5673.0, 5637.0, 5469.0, 5343.0, 5426.0, 5407.0, 5287.0, 5453.0, 5297.0, 5498.0, 5429.0, 5362.0, 5550.0, 5661.0, 5348.0, 5253.0, 5682.0, 5369.0, 5442.0, 5458.0, 5317.0, 5401.0, 5331.0, 5476.0, 5509.0, 5656.0, 5406.0, 5276.0, 5305.0, 5695.0, 5274.0, 5448.0, 5272.0, 5445.0, 5408.0, 5514.0, 5267.0, 5302.0, 5502.0, 5383.0, 5400.0, 5385.0, 5334.0, 5591.0, 5567.0, 5511.0, 5376.0, 5701.0, 5451.0, 5527.0, 5536.0, 5291.0, 5329.0, 5432.0, 5519.0, 5552.0, 5358.0, 5696.0, 5583.0, 5645.0 (number of hits: 17)
23	5330	9	1	333	1	5394.0, 5654.0, 5521.0, 5663.0, 5611.0, 5683.0, 5519.0, 5335.0, 5632.0, 5459.0, 5411.0, 5531.0, 5402.0, 5301.0, 5714.0, 5630.0, 5545.0, 5717.0, 5616.0, 5314.0, 5293.0, 5506.0, 5319.0, 5287.0, 5643.0, 5464.0, 5338.0, 5313.0, 5657.0, 5500.0, 5439.0, 5525.0, 5351.0, 5366.0, 5429.0, 5598.0, 5572.0, 5339.0, 5527.0, 5373.0, 5561.0, 5686.0, 5322.0, 5645.0, 5511.0, 5502.0, 5529.0, 5315.0, 5270.0, 5546.0, 5400.0, 5722.0, 5554.0, 5456.0, 5556.0, 5371.0, 5468.0, 5623.0, 5613.0, 5294.0, 5702.0, 5492.0, 5495.0, 5383.0, 5646.0, 5536.0, 5655.0, 5355.0, 5362.0, 5590.0, 5462.0, 5659.0, 5526.0, 5684.0, 5430.0, 5446.0, 5436.0, 5711.0, 5661.0, 5440.0, 5257.0, 5431.0, 5682.0, 5320.0, 5555.0, 5451.0, 5573.0, 5550.0, 5560.0, 5417.0, 5690.0, 5345.0, 5671.0, 5496.0, 5318.0, 5340.0, 5610.0, 5277.0, 5268.0, 5594.0 (number of hits: 19)
24	5330	9	1	333	1	5283.0, 5674.0, 5499.0, 5442.0, 5338.0, 5696.0, 5603.0, 5677.0, 5640.0, 5542.0, 5627.0, 5520.0, 5704.0, 5254.0, 5493.0, 5451.0, 5595.0, 5426.0, 5547.0, 5294.0, 5688.0, 5334.0, 5505.0, 5477.0, 5322.0, 5562.0, 5620.0, 5672.0, 5623.0, 5427.0, 5365.0, 5625.0, 5593.0, 5523.0, 5441.0, 5700.0, 5551.0, 5473.0, 5599.0, 5269.0, 5371.0, 5367.0, 5665.0, 5706.0, 5352.0, 5466.0, 5679.0, 5457.0, 5645.0, 5676.0, 5311.0, 5584.0, 5472.0, 5305.0, 5438.0, 5682.0, 5481.0, 5613.0, 5444.0, 5536.0, 5288.0, 5396.0, 5527.0, 5403.0, 5411.0, 5549.0, 5681.0, 5666.0, 5503.0, 5661.0, 5707.0, 5278.0, 5413.0, 5657.0, 5373.0, 5303.0, 5296.0, 5609.0, 5421.0, 5454.0, 5408.0, 5720.0, 5550.0, 5289.0, 5284.0, 5272.0, 5384.0, 5659.0, 5349.0, 5328.0, 5491.0, 5335.0, 5346.0, 5716.0, 5573.0,

						5633.0, 5309.0, 5646.0, 5709.0, 5525.0 (number of hits: 16)
25	5330	9	1	333	1	5705.0, 5691.0, 5274.0, 5440.0, 5704.0, 5599.0, 5369.0, 5432.0, 5333.0, 5341.0, 5433.0, 5597.0, 5329.0, 5462.0, 5517.0, 5421.0, 5414.0, 5561.0, 5596.0, 5519.0, 5534.0, 5415.0, 5541.0, 5498.0, 5707.0, 5488.0, 5613.0, 5317.0, 5383.0, 5509.0, 5289.0, 5511.0, 5431.0, 5625.0, 5530.0, 5429.0, 5377.0, 5635.0, 5428.0, 5631.0, 5454.0, 5700.0, 5661.0, 5370.0, 5474.0, 5590.0, 5323.0, 5703.0, 5591.0, 5364.0, 5620.0, 5711.0, 5656.0, 5348.0, 5445.0, 5426.0, 5621.0, 5485.0, 5368.0, 5644.0, 5322.0, 5669.0, 5410.0, 5444.0, 5392.0, 5699.0, 5319.0, 5471.0, 5678.0, 5355.0, 5588.0, 5695.0, 5265.0, 5663.0, 5283.0, 5269.0, 5696.0, 5615.0, 5441.0, 5722.0, 5660.0, 5612.0, 5313.0, 5618.0, 5571.0, 5665.0, 5457.0, 5572.0, 5533.0, 5436.0, 5676.0, 5547.0, 5585.0, 5629.0, 5719.0, 5468.0, 5343.0, 5409.0, 5586.0, 5442.0 (number of hits: 14)
26	5330	9	1	333	1	5497.0, 5379.0, 5571.0, 5358.0, 5373.0, 5554.0, 5695.0, 5296.0, 5556.0, 5590.0, 5702.0, 5677.0, 5527.0, 5366.0, 5586.0, 5618.0, 5275.0, 5428.0, 5322.0, 5653.0, 5678.0, 5291.0, 5321.0, 5427.0, 5718.0, 5583.0, 5490.0, 5323.0, 5532.0, 5431.0, 5645.0, 5603.0, 5362.0, 5298.0, 5495.0, 5371.0, 5607.0, 5272.0, 5265.0, 5381.0, 5596.0, 5625.0, 5508.0, 5480.0, 5420.0, 5644.0, 5443.0, 5425.0, 5582.0, 5421.0, 5579.0, 5587.0, 5399.0, 5305.0, 5442.0, 5270.0, 5684.0, 5522.0, 5344.0, 5478.0, 5389.0, 5567.0, 5594.0, 5499.0, 5679.0, 5350.0, 5498.0, 5689.0, 5548.0, 5326.0, 5343.0, 5290.0, 5600.0, 5466.0, 5549.0, 5655.0, 5405.0, 5509.0, 5698.0, 5663.0, 5287.0, 5488.0, 5573.0, 5459.0, 5659.0, 5355.0, 5352.0, 5608.0, 5394.0, 5407.0, 5704.0, 5392.0, 5675.0, 5553.0, 5378.0, 5415.0, 5612.0, 5652.0, 5263.0, 5304.0 (number of hits: 18)
27	5330	9	1	333	1	5347.0, 5699.0, 5454.0, 5322.0, 5571.0, 5617.0, 5446.0, 5390.0, 5504.0, 5565.0, 5391.0, 5694.0, 5708.0, 5704.0, 5403.0, 5320.0, 5388.0, 5252.0, 5689.0, 5610.0, 5306.0, 5482.0, 5376.0, 5369.0, 5590.0, 5370.0, 5491.0, 5525.0, 5626.0, 5444.0, 5601.0, 5405.0, 5686.0, 5299.0, 5606.0, 5289.0, 5531.0, 5448.0, 5324.0, 5348.0, 5295.0, 5416.0, 5464.0, 5286.0, 5545.0, 5515.0, 5374.0, 5463.0, 5692.0, 5662.0, 5319.0, 5493.0, 5636.0, 5556.0, 5514.0, 5383.0, 5326.0, 5413.0, 5342.0, 5280.0, 5452.0, 5512.0, 5649.0, 5710.0, 5290.0, 5307.0, 5655.0, 5701.0, 5698.0, 5456.0, 5549.0, 5457.0, 5321.0, 5283.0, 5614.0, 5490.0, 5434.0, 5458.0, 5499.0, 5465.0, 5589.0, 5548.0, 5603.0, 5645.0, 5316.0

						5410.0, 5656.0, 5473.0, 5356.0, 5415.0, 5336.0, 5503.0, 5401.0, 5564.0, 5486.0, 5271.0, 5443.0, 5468.0, 5298.0, 5332.0 (number of hits: 20)
28	5330	9	1	333	1	5406.0, 5490.0, 5387.0, 5255.0, 5431.0, 5715.0, 5574.0, 5544.0, 5705.0, 5253.0, 5571.0, 5271.0, 5599.0, 5448.0, 5689.0, 5494.0, 5711.0, 5312.0, 5520.0, 5294.0, 5338.0, 5556.0, 5420.0, 5603.0, 5496.0, 5317.0, 5345.0, 5675.0, 5415.0, 5515.0, 5365.0, 5501.0, 5302.0, 5562.0, 5295.0, 5683.0, 5462.0, 5458.0, 5457.0, 5400.0, 5701.0, 5257.0, 5272.0, 5642.0, 5391.0, 5354.0, 5522.0, 5402.0, 5464.0, 5624.0, 5331.0, 5621.0, 5652.0, 5510.0, 5268.0, 5280.0, 5579.0, 5289.0, 5326.0, 5425.0, 5301.0, 5350.0, 5455.0, 5641.0, 5596.0, 5254.0, 5306.0, 5664.0, 5440.0, 5347.0, 5678.0, 5269.0, 5591.0, 5630.0, 5650.0, 5466.0, 5499.0, 5472.0, 5524.0, 5668.0, 5251.0, 5401.0, 5416.0, 5628.0, 5697.0, 5383.0, 5488.0, 5442.0, 5432.0, 5535.0, 5315.0, 5527.0, 5523.0, 5361.0, 5567.0, 5279.0, 5398.0, 5355.0, 5424.0, 5460.0 (number of hits: 18)
29	5330	9	1	333	1	5268.0, 5643.0, 5319.0, 5308.0, 5436.0, 5686.0, 5706.0, 5385.0, 5402.0, 5683.0, 5592.0, 5503.0, 5430.0, 5647.0, 5690.0, 5407.0, 5363.0, 5272.0, 5654.0, 5603.0, 5650.0, 5591.0, 5668.0, 5325.0, 5540.0, 5679.0, 5286.0, 5694.0, 5353.0, 5412.0, 5406.0, 5411.0, 5530.0, 5343.0, 5674.0, 5417.0, 5370.0, 5508.0, 5716.0, 5525.0, 5423.0, 5295.0, 5450.0, 5697.0, 5630.0, 5607.0, 5251.0, 5498.0, 5410.0, 5256.0, 5608.0, 5516.0, 5514.0, 5552.0, 5709.0, 5586.0, 5253.0, 5279.0, 5611.0, 5641.0, 5271.0, 5422.0, 5360.0, 5576.0, 5502.0, 5391.0, 5623.0, 5408.0, 5510.0, 5311.0, 5487.0, 5657.0, 5444.0, 5663.0, 5266.0, 5561.0, 5691.0, 5338.0, 5357.0, 5326.0, 5640.0, 5580.0, 5331.0, 5685.0, 5544.0, 5698.0, 5687.0, 5397.0, 5254.0, 5598.0, 5633.0, 5418.0, 5658.0, 5379.0, 5346.0, 5252.0, 5438.0, 5577.0, 5631.0, 5564.0 (number of hits: 14)
30	5330	9	1	333	1	5392.0, 5526.0, 5496.0, 5432.0, 5332.0, 5670.0, 5718.0, 5669.0, 5460.0, 5582.0, 5472.0, 5453.0, 5508.0, 5689.0, 5724.0, 5266.0, 5535.0, 5554.0, 5638.0, 5289.0, 5303.0, 5684.0, 5283.0, 5629.0, 5644.0, 5356.0, 5706.0, 5268.0, 5532.0, 5628.0, 5411.0, 5663.0, 5430.0, 5330.0, 5594.0, 5468.0, 5374.0, 5343.0, 5497.0, 5552.0, 5422.0, 5295.0, 5297.0, 5426.0, 5410.0, 5269.0, 5342.0, 5563.0, 5434.0, 5463.0, 5578.0, 5344.0, 5604.0, 5376.0, 5634.0, 5251.0, 5566.0, 5464.0, 5661.0, 5296.0, 5276.0, 5466.0, 5354.0, 5428.0, 5322.0, 5569.0, 5571.0, 5589.0, 5477.0, 5423.0, 5605.0, 5509.0, 5494.0, 5576.0, 5462.0,

						5471.0, 5520.0, 5433.0, 5446.0, 5351.0, 5362.0, 5560.0, 5603.0, 5287.0, 5518.0, 5657.0, 5607.0, 5403.0, 5697.0, 5467.0, 5507.0, 5698.0, 5458.0, 5521.0, 5274.0, 5370.0, 5412.0, 5457.0, 5267.0, 5575.0 (number of hits: 14)
--	--	--	--	--	--	---

Appendix B – U-NII-2C Radar Parameter Data Sheet

A.1 20 MHz Bandwidth @ 5500 MHz

Table-1A/1B Radar Type 1A/1B Statistical Performance

Trial #	Fc (MHz)	Pulse/Burst	Pulse Width (µS)	PRI (µs)	Detection (1:yes; 0:no)
1	5490	57	1	938	1
2	5490	58	1	918	1
3	5490	61	1	878	1
4	5490	92	1	578	1
5	5490	65	1	818	1
6	5500	68	1	778	1
7	5500	86	1	618	1
8	5500	59	1	898	1
9	5500	99	1	538	1
10	5500	63	1	838	1
11	5510	72	1	738	1
12	5510	67	1	798	1
13	5510	70	1	758	1
14	5510	78	1	678	0
15	5510	95	1	558	1
16	5490	31	1	1759	1
17	5490	20	1	2649	1
18	5490	35	1	1542	1
19	5490	86	1	616	1
20	5490	22	1	2449	1
21	5500	22	1	2451	1
22	5500	22	1	2436	1
23	5500	18	1	2986	1
24	5500	19	1	2886	1
25	5500	27	1	2012	1
26	5510	19	1	2779	0
27	5510	19	1	2801	1
28	5510	35	1	1548	1
29	5510	47	1	1129	1
30	5510	26	1	2080	1
Detection Percentage: 93.33 % (>60%)					

Table-2 Radar Type 2 Statistical Performance

Trial #	Fc (MHz)	Pulse/Burst	Pulse Width (μS)	PRI (μs)	Detection (1:yes; 0:no)
1	5490	26	4.2	222	1
2	5490	25	3	197	1
3	5490	29	2.9	214	1
4	5490	26	4.7	152	1
5	5490	28	3.2	180	1
6	5490	25	3	157	1
7	5490	29	3.1	203	1
8	5490	26	3.3	178	1
9	5490	27	4.4	225	1
10	5490	29	3	187	1
11	5500	28	2.6	162	1
12	5500	24	1.2	218	1
13	5500	28	1.7	171	1
14	5500	23	2.6	176	1
15	5500	25	3.7	151	1
16	5500	23	2.2	180	1
17	5500	25	2.8	172	1
18	5500	23	2.4	208	1
19	5500	29	3.6	183	1
20	5500	25	1.2	214	1
21	5510	24	3.8	174	1
22	5510	24	4.2	179	1
23	5510	29	2.8	230	1
24	5510	25	1.4	226	1
25	5510	28	4.1	156	1
26	5510	28	1.4	183	1
27	5510	23	2	229	0
28	5510	28	4.2	214	1
29	5510	28	2.4	209	1
30	5510	26	4	223	1
Detection Percentage: 96.67 % (>60%)					

Table-3 Radar Type 3 Statistical Performance

Trial #	Fc (MHz)	Pulse/Burst	Pulse Width (μ S)	PRI (μ s)	Detection (1:yes; 0:no)
1	5490	17	9.4	423	1
2	5490	17	9.8	288	1
3	5490	16	9.4	263	1
4	5490	17	8.3	247	1
5	5490	16	7.4	309	1
6	5490	16	6.2	499	1
7	5490	18	7.5	437	1
8	5490	17	6.3	378	1
9	5490	17	7.6	274	1
10	5490	17	8.5	448	1
11	5500	16	7.8	361	1
12	5500	17	7.3	305	1
13	5500	16	6	247	1
14	5500	18	8.9	345	1
15	5500	18	9.1	371	1
16	5500	16	8.1	348	1
17	5500	16	8	405	1
18	5500	17	8.6	239	1
19	5500	17	7.6	217	1
20	5500	18	7.9	481	1
21	5510	18	8.7	309	1
22	5510	18	6.6	296	1
23	5510	17	7.4	416	1
24	5510	16	7.7	304	1
25	5510	18	9	372	1
26	5510	18	7	320	1
27	5510	16	9.1	310	0
28	5510	16	9.2	218	1
29	5510	16	6.3	456	1
30	5510	16	7	395	0
Detection Percentage: 93.33 % (>60%)					

Table-4 Radar Type 4 Statistical Performance

Trial #	Fc (MHz)	Pulse/Burst	Pulse Width (μS)	PRI (μs)	Detection (1:yes; 0:no)
1	5490	15	14.8	398	1
2	5490	13	18.2	451	1
3	5490	15	16.6	338	1
4	5490	15	15.5	323	1
5	5490	13	19.6	482	1
6	5490	15	12.6	383	1
7	5490	15	11.6	490	1
8	5490	14	16.9	412	1
9	5490	16	19.4	341	1
10	5490	14	18.9	256	1
11	5500	12	11.4	279	1
12	5500	16	17.8	415	1
13	5500	13	12	456	1
14	5500	12	14.8	422	1
15	5500	15	18.6	324	1
16	5500	13	17.7	496	1
17	5500	13	14.5	477	1
18	5500	15	18.8	370	1
19	5500	13	18.1	423	1
20	5500	13	16.8	395	1
21	5510	14	17.9	293	1
22	5510	14	11.4	422	1
23	5510	12	16.7	380	0
24	5510	13	16.4	388	1
25	5510	14	12.8	374	1
26	5510	13	19.4	357	1
27	5510	15	14.9	288	1
28	5510	14	15.1	407	1
29	5510	16	14.2	441	1
30	5510	14	11.3	309	1
Detection Percentage: 96.67 % (>60%)					

Table-5 Radar Type 5 Statistical Performance

Trial #	Fc (MHz)	Detection (1:yes; 0:no)
1	5500	1
2	5500	1
3	5500	1
4	5500	1
5	5500	1
6	5500	1
7	5500	1
8	5500	1
9	5500	1
10	5500	1
11	5492.8	1
12	5496.4	0
13	5494.0	1
14	5494.4	1
15	5494.4	1
16	5492.8	1
17	5494.8	0
18	5493.6	1
19	5493.2	1
20	5492.4	1
21	5506.4	1
22	5502.4	1
23	5503.2	1
24	5506.0	1
25	5507.6	1
26	5507.6	1
27	5502.0	1
28	5502.4	1
29	5506.4	1
30	5503.6	1
Detection Percentage: 93.33 % (>80%)		

Bin5 Statistics 1

Trial #	Pulse	Chirp (MHz)	Pulse Width (µS)	Pulse 1-2 spacing (uS)	Pulse 2-3 spacing (uS)	Pulse Start(S)	Detection (1:yes; 0:no)
0	3	6	77.3	1462	1954	0.471184	1
1	2	6	61	1492		1.181725	
2	2	6	80.8	1170		1.430037	
3	2	6	83	1828		1.996959	
4	2	6	58.2	1001		2.932613	
5	2	6	91.5	1204		3.450776	
6	2	6	97.6	1357		4.372038	
7	2	6	50.9	1218		4.781441	
8	2	6	94.8	1045		5.617926	
9	2	6	67.8	1404		6.133988	
10	2	6	59.9	1366		6.870504	
11	2	6	54.9	1014		7.529551	
12	3	6	60	1713	1905	7.886397	
13	3	6	89.7	1537	1528	8.654131	
14	1	6	67.2			9.426641	
15	3	6	53.5	1180	1521	9.812212	
16	3	6	81.6	1216	1045	10.672196	
17	3	6	62.6	1785	1732	11.085992	
18	2	6	97.6	1766		11.902052	

Bin5 Statistics 2

Trial #	Pulse	Chirp (MHz)	Pulse Width (µS)	Pulse 1-2 spacing (uS)	Pulse 2-3 spacing (uS)	Pulse Start(S)	Detection (1:yes; 0:no)
0	2	16	96.1	1130		0.492936	1
1	2	16	67.2	1188		1.353257	
2	3	16	56.2	1750	1068	2.546319	
3	2	16	75.8	1083		4.109205	
4	3	16	92.4	1792	1557	4.780609	
5	3	16	85	1835	1918	6.167447	
6	1	16	54.5			6.906452	
7	1	16	68			7.700904	
8	2	16	64.7	1569		9.554053	
9	2	16	50.8	1984		10.559233	
10	2	16	90.5	1168		11.984931	

Bin5 Statistics 3

Trial #	Pulse	Chirp (MHz)	Pulse Width (µS)	Pulse 1-2 spacing (uS)	Pulse 2-3 spacing (uS)	Pulse Start(S)	Detection (1:yes; 0:no)
0	2	6	81.3	1415		0.442392	1
1	2	6	71	1991		0.998912	
2	2	6	50.1	1628		1.889346	
3	2	6	52.6	1592		3.096682	
4	2	6	94.5	1874		3.592322	
5	1	6	94.3			4.662847	
6	3	6	66.1	1835	1709	5.323351	
7	2	6	62.6	1752		6.379946	
8	2	6	89.9	1172		7.538316	
9	1	6	68.5			7.7903	
10	3	6	68.6	1500	1052	9.115172	
11	2	6	98.9	1108		9.857474	
12	2	6	82.7	1474		10.68507	
13	2	6	90.4	1261		11.946904	

Bin5 Statistics 4

Trial #	Pulse	Chirp (MHz)	Pulse Width (µS)	Pulse 1-2 spacing (uS)	Pulse 2-3 spacing (uS)	Pulse Start(S)	Detection (1:yes; 0:no)
0	3	5	56.5	1153	1791	0.362601	1
1	2	5	82.8	1906		0.961825	
2	2	5	55.6	1692		1.695641	
3	1	5	96.7			2.374608	
4	1	5	61.2			2.555772	
5	2	5	90.1	1616		3.170038	
6	3	5	85.7	1328	1401	3.899004	
7	3	5	61.2	1155	1910	4.489278	
8	2	5	56.4	1340		5.277637	
9	2	5	64.3	1981		5.70218	
10	1	5	88.2			6.34729	
11	3	5	81.9	1387	1773	7.116002	
12	2	5	75.4	1312		7.670151	
13	3	5	99.6	1649	1652	8.223773	
14	1	5	53.6			9.108635	
15	2	5	93	1789		9.971004	
16	3	5	87.1	1141	1041	10.461381	
17	3	5	67.7	1328	1936	11.143063	
18	1	5	91.7			11.599759	

Bin5 Statistics 5

Trial #	Pulse	Chirp (MHz)	Pulse Width (μ S)	Pulse 1-2 spacing (μ S)	Pulse 2-3 spacing (μ S)	Pulse Start(S)	Detection (1:yes; 0:no)
0	1	14	51.8			0.687813	1
1	1	14	78.7			1.860223	
2	2	14	76.5	1413		2.942139	
3	1	14	81.4			3.490272	
4	1	14	86			5.216623	
5	3	14	69.2	1359	1451	5.69806	
6	1	14	80.5			7.227172	
7	2	14	78.9	1459		7.879195	
8	3	14	58.7	1240	1390	9.048564	
9	3	14	94.1	1383	1691	10.725829	
10	1	14	86.7			11.224111	

Bin5 Statistics 6

Trial #	Pulse	Chirp (MHz)	Pulse Width (μ S)	Pulse 1-2 spacing (μ S)	Pulse 2-3 spacing (μ S)	Pulse Start(S)	Detection (1:yes; 0:no)
0	2	12	89.9	1886		0.544249	1
1	3	12	79.8	1189	1713	2.362955	
2	1	12	66.3			3.810393	
3	2	12	99.8	1203		5.211343	
4	2	12	73.6	1024		6.313358	
5	3	12	78.5	1564	1717	7.884346	
6	3	12	55	1158	1898	8.076719	
7	3	12	83.5	1209	1472	10.58631	
8	2	12	56.4	1633		10.961721	

Bin5 Statistics 7

Trial #	Pulse	Chirp (MHz)	Pulse Width (µS)	Pulse 1-2 spacing (uS)	Pulse 2-3 spacing (uS)	Pulse Start(S)	Detection (1:yes; 0:no)
0	1	8	80.8			0.539561	1
1	3	8	51.3	1977	1755	0.965214	
2	1	8	87.6			1.449097	
3	2	8	69.3	1118		2.346149	
4	1	8	77.9			3.195669	
5	1	8	51.1			3.959908	
6	1	8	88.4			4.830268	
7	3	8	82.6	1029	1451	5.602273	
8	2	8	81	1309		5.706164	
9	2	8	78.2	1913		6.447367	
10	3	8	74.5	1793	1657	7.633513	
11	2	8	90.1	1496		8.398494	
12	1	8	64.3			8.821798	
13	2	8	50.6	1050		9.679651	
14	2	8	84.1	1582		10.288906	
15	3	8	57.4	1201	1544	11.204705	
16	2	8	60	1764		11.660119	

Bin5 Statistics 8

Trial #	Pulse	Chirp (MHz)	Pulse Width (µS)	Pulse 1-2 spacing (uS)	Pulse 2-3 spacing (uS)	Pulse Start(S)	Detection (1:yes; 0:no)
0	3	14	78.1	1156	1851	0.266031	1
1	2	14	86.7	1099		1.67356	
2	1	14	59.3			3.588397	
3	2	14	69	1609		4.429787	
4	2	14	84	1266		5.736018	
5	2	14	71.9	1769		7.124888	
6	2	14	87.4	1668		7.554694	
7	3	14	86.3	1980	1770	8.976062	
8	2	14	54.7	1770		9.818528	
9	1	14	56.3			11.396016	

Bin5 Statistics 9

Trial #	Pulse	Chirp (MHz)	Pulse Width (µS)	Pulse 1-2 spacing (µS)	Pulse 2-3 spacing (µS)	Pulse Start(S)	Detection (1:yes; 0:no)
0	2	10	89.6	1939		0.132391	1
1	2	10	75.1	1428		0.886212	
2	1	10	63			1.671866	
3	1	10	51.9			2.381537	
4	2	10	75.6	1957		2.617877	
5	3	10	98.4	1717	1152	3.163009	
6	3	10	84.3	1983	1822	3.611777	
7	3	10	64.2	1165	1517	4.248754	
8	3	10	65.6	1847	1203	5.348656	
9	1	10	57.6			5.735307	
10	2	10	50.7	1655		6.485148	
11	3	10	79.4	1477	1188	7.021971	
12	3	10	54.2	1451	1976	7.201197	
13	2	10	81.6	1626		8.073687	
14	3	10	87.5	1981	1618	8.744301	
15	2	10	81.1	1255		9.113026	
16	1	10	75.9			9.635642	
17	1	10	83.6			10.765218	
18	2	10	55.9	1796		11.335872	
19	2	10	84.9	1944		11.950759	

Bin5 Statistics 10

Trial #	Pulse	Chirp (MHz)	Pulse Width (µS)	Pulse 1-2 spacing (µS)	Pulse 2-3 spacing (µS)	Pulse Start(S)	Detection (1:yes; 0:no)
0	2	11	56.1	1367		0.341543	1
1	3	11	93	1618	1963	1.219726	
2	2	11	57.2	1290		2.058211	
3	3	11	67.3	1482	1967	3.453191	
4	3	11	95.5	1960	1290	4.362662	
5	2	11	60.3	1546		5.034946	
6	2	11	57.2	1716		6.577514	
7	1	11	87.8			7.946908	
8	1	11	66.4			8.407873	
9	1	11	66.7			9.303943	
10	3	11	70.9	1901	1546	10.742367	
11	2	11	98.7	1346		11.446706	

Bin5 Statistics 11

Trial #	Pulse	Chirp (MHz)	Pulse Width (µS)	Pulse 1-2 spacing (uS)	Pulse 2-3 spacing (uS)	Pulse Start(S)	Detection (1:yes; 0:no)
0	3	7	84.4	1917	1512	0.617136	1
1	3	7	82.8	1795	1724	0.892888	
2	2	7	71.6	1557		1.625427	
3	2	7	95.7	1708		2.239203	
4	2	7	67.8	1754		2.973996	
5	3	7	94	1450	1395	3.722495	
6	2	7	96.9	1767		4.32597	
7	2	7	79	1996		4.473271	
8	3	7	98.8	1121	1787	5.411288	
9	1	7	73.4			5.99673	
10	2	7	57.1	1995		6.543807	
11	2	7	72.4	1548		7.154067	
12	2	7	76.3	1620		7.671302	
13	3	7	58.3	1743	1323	8.379264	
14	2	7	79.6	1098		9.030651	
15	3	7	69.4	1812	1536	9.483475	
16	2	7	57.5	1515		10.703517	
17	2	7	82.7	1708		10.862693	
18	3	7	94.1	1631	1942	11.594296	

Bin5 Statistics 12

Trial #	Pulse	Chirp (MHz)	Pulse Width (µS)	Pulse 1-2 spacing (uS)	Pulse 2-3 spacing (uS)	Pulse Start(S)	Detection (1:yes; 0:no)
0	1	16	50.3			0.247688	0
1	2	16	52.8	1707		1.661941	
2	2	16	63.2	1678		3.666035	
3	2	16	82.4	1925		5.099681	
4	3	16	57.4	1423	1662	5.488505	
5	3	16	66.4	1123	1164	6.797125	
6	2	16	69.7	1535		9.199801	
7	1	16	61.2			9.851303	
8	3	16	85.1	1423	1066	11.465747	

Bin5 Statistics 13

Trial #	Pulse	Chirp (MHz)	Pulse Width (µS)	Pulse 1-2 spacing (uS)	Pulse 2-3 spacing (uS)	Pulse Start(S)	Detection (1:yes; 0:no)
0	3	10	61.6	1074	1080	0.038104	1
1	3	10	98.1	1681	1632	2.188154	
2	2	10	92.1	1655		3.4725	
3	2	10	56.5	1351		4.694008	
4	2	10	63.5	1753		7.388971	
5	2	10	69.6	1034		7.886887	
6	2	10	86.6	1531		10.266577	
7	2	10	68.8	1628		10.784401	

Bin5 Statistics 14

Trial #	Pulse	Chirp (MHz)	Pulse Width (µS)	Pulse 1-2 spacing (uS)	Pulse 2-3 spacing (uS)	Pulse Start(S)	Detection (1:yes; 0:no)
0	2	11	53.1	1789		0.114446	1
1	3	11	53.9	1169	1125	0.975726	
2	2	11	55.8	1002		2.058694	
3	1	11	64.7			3.254056	
4	2	11	59.7	1702		3.756978	
5	1	11	99.3			4.99512	
6	2	11	97.3	1520		5.440231	
7	2	11	84.4	1327		6.137944	
8	2	11	53.8	1663		7.160377	
9	2	11	78.6	1223		8.468852	
10	2	11	73.5	1063		9.346813	
11	1	11	83.1			9.667544	
12	1	11	74.5			11.001863	
13	3	11	55.4	1616	1625	11.705144	

Bin5 Statistics 15

Trial #	Pulse	Chirp (MHz)	Pulse Width (µS)	Pulse 1-2 spacing (uS)	Pulse 2-3 spacing (uS)	Pulse Start(S)	Detection (1:yes; 0:no)
0	2	11	81.1	1161		0.613193	1
1	2	11	60.2	1470		0.909309	
2	2	11	91.8	1818		1.450526	
3	1	11	79.3			1.904287	
4	2	11	79	1488		3.091212	
5	2	11	60.3	1121		3.759867	
6	2	11	91.9	1556		4.06237	
7	1	11	96.4			4.579217	
8	2	11	86.7	1540		5.571913	
9	3	11	77.8	1764	1435	5.959738	
10	2	11	53.2	1534		6.386067	
11	2	11	53.7	1096		7.241342	
12	2	11	64.2	1329		7.698941	
13	3	11	86.7	1156	1105	8.752015	
14	3	11	81.3	1879	1335	9.064434	
15	3	11	70.9	1913	1044	9.665098	
16	2	11	88.4	1820		10.696357	
17	1	11	91.5			11.150474	
18	3	11	50.1	1193	1722	11.734848	

Bin5 Statistics 16

Trial #	Pulse	Chirp (MHz)	Pulse Width (µS)	Pulse 1-2 spacing (µS)	Pulse 2-3 spacing (µS)	Pulse Start(S)	Detection (1:yes; 0:no)
0	2	7	77	1585		0.236034	1
1	1	7	85			1.072762	
2	2	7	70.5	1259		1.620042	
3	3	7	55.9	1006	1082	2.342996	
4	3	7	69.2	1339	1889	2.529434	
5	2	7	84	1272		3.2163	
6	1	7	60.8			4.263709	
7	2	7	51.9	1844		4.713933	
8	2	7	81.1	1274		5.169843	
9	3	7	62.2	1753	1121	6.033582	
10	2	7	82.3	1614		6.539874	
11	2	7	85.5	1590		7.089981	
12	2	7	97.7	1914		8.087838	
13	2	7	81.4	1121		8.637457	
14	2	7	89.9	1077		8.879588	
15	3	7	70.5	1702	1857	9.534224	
16	3	7	60.4	1825	1548	10.281368	
17	3	7	51.3	1663	1487	10.962843	
18	2	7	87.8	1673		11.658832	

Bin5 Statistics 17

Trial #	Pulse	Chirp (MHz)	Pulse Width (µS)	Pulse 1-2 spacing (µS)	Pulse 2-3 spacing (µS)	Pulse Start(S)	Detection (1:yes; 0:no)
0	1	12	96.4			0.549142	0
1	2	12	77	1759		1.512317	
2	3	12	72.7	1902	1149	2.229745	
3	2	12	90.1	1810		3.383206	
4	2	12	68.2	1061		4.586011	
5	1	12	69.5			5.625902	
6	1	12	77.1			6.154731	
7	2	12	99.6	1840		7.834521	
8	2	12	66.4	1472		8.162296	
9	2	12	79.7	1065		9.133254	
10	3	12	55.5	1786	1264	10.010266	
11	3	12	77.8	1928	1580	11.310108	

Bin5 Statistics 18

Trial #	Pulse	Chirp (MHz)	Pulse Width (µS)	Pulse 1-2 spacing (uS)	Pulse 2-3 spacing (uS)	Pulse Start(S)	Detection (1:yes; 0:no)
0	1	9	77.9			0.736447	1
1	3	9	65.5	1285	1741	2.437757	
2	2	9	88.3	1286		3.56748	
3	3	9	53.8	1216	1710	5.019204	
4	1	9	52.7			5.379481	
5	1	9	90.2			7.407745	
6	3	9	90.9	1837	1975	9.078445	
7	2	9	62	1743		10.265721	
8	2	9	58.9	1808		11.316401	

Bin5 Statistics 19

Trial #	Pulse	Chirp (MHz)	Pulse Width (µS)	Pulse 1-2 spacing (uS)	Pulse 2-3 spacing (uS)	Pulse Start(S)	Detection (1:yes; 0:no)
0	2	8	75.8	1548		0.155917	1
1	2	8	77.3	1701		0.916595	
2	2	8	68.2	1688		2.006604	
3	1	8	55			2.394297	
4	2	8	71.9	1498		3.626295	
5	2	8	78.1	1243		3.956526	
6	2	8	77.3	1786		4.50396	
7	2	8	68.5	1897		5.855778	
8	3	8	76.9	1403	1371	6.045611	
9	1	8	52			7.400646	
10	2	8	51.3	1719		7.692432	
11	1	8	52.6			8.26474	
12	3	8	59.7	1040	1241	9.393829	
13	2	8	94.8	1299		10.475843	
14	2	8	65.7	1333		10.762562	
15	3	8	82.6	1603	1118	11.507522	

Bin5 Statistics 20

Trial #	Pulse	Chirp (MHz)	Pulse Width (µS)	Pulse 1-2 spacing (uS)	Pulse 2-3 spacing (uS)	Pulse Start(S)	Detection (1:yes; 0:no)
0	2	6	58.2	1123		1.129943	1
1	3	6	66.6	1365	1010	1.270527	
2	2	6	88.7	1550		3.337834	
3	3	6	58.6	1605	1694	3.757718	
4	2	6	52	1269		5.835023	
5	2	6	69.3	1493		6.919732	
6	3	6	99.3	1470	1634	7.721727	
7	2	6	64	1983		9.440948	
8	2	6	57.5	1554		9.938779	
9	3	6	54.5	1896	1508	11.634134	

Bin5 Statistics 21

Trial #	Pulse	Chirp (MHz)	Pulse Width (µS)	Pulse 1-2 spacing (uS)	Pulse 2-3 spacing (uS)	Pulse Start(S)	Detection (1:yes; 0:no)
0	2	9	92.5	1616		0.132403	1
1	2	9	52.6	1499		1.097396	
2	2	9	80.9	1771		2.596183	
3	1	9	93.8			3.341792	
4	1	9	79.8			4.080032	
5	1	9	88.6			4.637294	
6	2	9	81.6	1147		5.999388	
7	2	9	82.5	1625		7.054522	
8	3	9	61.2	1407	1287	8.281712	
9	3	9	72.7	1321	1681	8.415474	
10	1	9	72.2			9.348073	
11	2	9	65.5	1420		10.394667	
12	2	9	69.4	1242		11.869401	

Bin5 Statistics 22

Trial #	Pulse	Chirp (MHz)	Pulse Width (µS)	Pulse 1-2 spacing (uS)	Pulse 2-3 spacing (uS)	Pulse Start(S)	Detection (1:yes; 0:no)
0	2	19	89.3	1070		0.497875	1
1	2	19	63.4	1082		2.277582	
2	2	19	82.2	1510		2.947734	
3	3	19	74.3	1313	1436	4.674755	
4	1	19	97.3			5.795457	
5	2	19	61.3	1255		6.260929	
6	2	19	77.1	1331		8.031332	
7	2	19	55.6	1791		8.922823	
8	2	19	59.5	1717		10.480363	
9	1	19	77.2			11.565405	

Bin5 Statistics 23

Trial #	Pulse	Chirp (MHz)	Pulse Width (µS)	Pulse 1-2 spacing (uS)	Pulse 2-3 spacing (uS)	Pulse Start(S)	Detection (1:yes; 0:no)
0	2	17	76.1	1058		0.153143	1
1	2	17	71.8	1639		1.1625	
2	2	17	92.4	1228		1.778353	
3	2	17	64.9	1116		2.640607	
4	2	17	83.8	1218		3.617565	
5	3	17	97.2	1584	1512	4.552246	
6	2	17	50.1	1790		5.238995	
7	2	17	93.6	1118		6.130116	
8	2	17	76	1453		6.927069	
9	3	17	62.9	1630	1709	7.712344	
10	3	17	99.2	1211	1628	8.556769	
11	3	17	68.5	1541	1242	8.835396	
12	2	17	74.9	1116		9.787285	
13	2	17	73.6	1916		11.177026	
14	2	17	84.3	1234		11.427055	

Bin5 Statistics 24

Trial #	Pulse	Chirp (MHz)	Pulse Width (µS)	Pulse 1-2 spacing (uS)	Pulse 2-3 spacing (uS)	Pulse Start(S)	Detection (1:yes; 0:no)
0	1	10	90.2			0.542335	1
1	2	10	85.3	1073		1.517764	
2	3	10	53	1124	1812	3.538129	
3	1	10	85.1			4.661624	
4	3	10	54.6	1616	1414	5.643283	
5	2	10	82.3	1521		6.381806	
6	2	10	50.6	1353		8.085696	
7	2	10	91.6	1583		9.477291	
8	2	10	82.5	1996		9.669472	
9	2	10	53.1	1113		10.819751	

Bin5 Statistics 25

Trial #	Pulse	Chirp (MHz)	Pulse Width (µS)	Pulse 1-2 spacing (uS)	Pulse 2-3 spacing (uS)	Pulse Start(S)	Detection (1:yes; 0:no)
0	2	6	78.9	1856		0.538496	1
1	3	6	97.9	1723	1251	1.170255	
2	1	6	79.2			2.185463	
3	2	6	63.8	1141		2.6113	
4	2	6	87.7	1941		3.307715	
5	2	6	75.8	1872		3.863489	
6	2	6	74.4	1179		4.673044	
7	1	6	60.1			5.493418	
8	2	6	72.1	1008		6.606963	
9	1	6	72.6			6.76454	
10	3	6	77.4	1391	1234	8.131498	
11	3	6	66.9	1856	1326	8.381667	
12	1	6	81.7			9.411628	
13	2	6	86.4	1412		10.347219	
14	3	6	82.5	1656	1741	10.517644	
15	1	6	93			11.645305	

Bin5 Statistics 26

Trial #	Pulse	Chirp (MHz)	Pulse Width (µS)	Pulse 1-2 spacing (uS)	Pulse 2-3 spacing (uS)	Pulse Start(S)	Detection (1:yes; 0:no)
0	2	6	61.6	1931		1.14168	1
1	2	6	69.7	1600		1.665668	
2	1	6	81.3			2.57995	
3	2	6	76.6	1777		4.597199	
4	2	6	59.9	1045		5.483752	
5	2	6	81.5	1961		6.885062	
6	2	6	87.9	1001		7.849285	
7	2	6	72.3	1112		9.461136	
8	3	6	68.6	1083	1029	9.843199	
9	2	6	95.4	1016		11.344931	

Bin5 Statistics 27

Trial #	Pulse	Chirp (MHz)	Pulse Width (µS)	Pulse 1-2 spacing (uS)	Pulse 2-3 spacing (uS)	Pulse Start(S)	Detection (1:yes; 0:no)
0	1	20	89.3			0.091916	1
1	3	20	96.5	1278	1456	1.36355	
2	1	20	80.7			1.436189	
3	1	20	70.9			2.240496	
4	2	20	77.8	1343		3.392754	
5	3	20	82.2	1761	1181	3.540507	
6	3	20	55.2	1268	1975	4.431749	
7	2	20	73.9	1213		5.184611	
8	1	20	79.1			5.670215	
9	1	20	56.1			6.364819	
10	2	20	69.1	1243		7.636119	
11	3	20	68.5	1680	1041	8.171432	
12	3	20	82.3	1643	1904	9.057091	
13	1	20	64			9.711641	
14	2	20	61.8	1615		10.264234	
15	1	20	60.7			10.739869	
16	1	20	96.8			11.812003	

Bin5 Statistics 28

Trial #	Pulse	Chirp (MHz)	Pulse Width (µS)	Pulse 1-2 spacing (uS)	Pulse 2-3 spacing (uS)	Pulse Start(S)	Detection (1:yes; 0:no)
0	2	19	61.1	1004		0.057024	1
1	3	19	90.8	1333	1963	1.206773	
2	3	19	84.2	1702	1902	2.686602	
3	2	19	75.6	1659		3.722945	
4	2	19	88.6	1356		4.832373	
5	2	19	95.8	1917		5.975936	
6	3	19	87.1	1679	1405	6.331937	
7	3	19	91.6	1560	1641	7.657271	
8	2	19	75.7	1966		8.939546	
9	1	19	71.2			9.552017	
10	3	19	74.9	1098	1192	10.521263	
11	2	19	98.6	1962		11.465904	

Bin5 Statistics 29

Trial #	Pulse	Chirp (MHz)	Pulse Width (µS)	Pulse 1-2 spacing (uS)	Pulse 2-3 spacing (uS)	Pulse Start(S)	Detection (1:yes; 0:no)
0	2	9	98.3	1294		0.434566	1
1	2	9	84	1275		1.568303	
2	2	9	95.2	1878		2.380177	
3	2	9	65.4	1382		2.671658	
4	2	9	81.1	1415		3.297036	
5	1	9	95.9			4.061219	
6	2	9	78.2	1500		5.238954	
7	1	9	73.2			6.137552	
8	1	9	54.1			6.532625	
9	1	9	64.9			7.420228	
10	2	9	97.5	1309		8.467557	
11	3	9	76.9	1475	1412	8.859272	
12	2	9	74.9	1355		9.642229	
13	2	9	67.4	1505		10.622301	
14	3	9	67	1967	1303	11.838056	

Bin5 Statistics 30

Trial #	Pulse	Chirp (MHz)	Pulse Width (µS)	Pulse 1-2 spacing (uS)	Pulse 2-3 spacing (uS)	Pulse Start(S)	Detection (1:yes; 0:no)
0	2	16	93.8	1889		0.296517	1
1	3	16	90.5	1817	1089	1.590264	
2	2	16	66.3	1845		3.340459	
3	2	16	65.1	1484		5.098622	
4	1	16	73			6.35647	
5	3	16	50.5	1257	1797	7.148144	
6	3	16	56.7	1138	1030	8.298362	
7	1	16	77.1			10.463589	
8	3	16	99.5	1751	1882	11.871406	

Table-6 Radar Type 6 Statistical Performance

Trial #	Fc (MHz)	Pulse /Burst	Pulse Width (µS)	PRI (µs)	Detection (1:yes; 0:no)	Hopping Sequence
1	5490	9	1	333	1	5710.0, 5684.0, 5444.0, 5528.0, 5297.0, 5649.0, 5678.0, 5501.0, 5539.0, 5389.0, 5373.0, 5529.0, 5589.0, 5523.0, 5319.0, 5469.0, 5370.0, 5667.0, 5551.0, 5351.0, 5298.0, 5723.0, 5479.0, 5251.0, 5366.0, 5511.0, 5498.0, 5691.0, 5459.0, 5695.0, 5494.0, 5410.0, 5703.0, 5486.0, 5534.0, 5588.0, 5404.0, 5372.0, 5614.0, 5326.0, 5258.0, 5418.0, 5324.0, 5445.0, 5526.0, 5320.0, 5300.0, 5420.0, 5506.0, 5637.0, 5318.0, 5717.0, 5712.0, 5427.0, 5622.0, 5419.0, 5387.0, 5565.0, 5706.0, 5531.0, 5333.0, 5533.0, 5361.0, 5255.0, 5396.0, 5593.0, 5572.0, 5562.0, 5568.0, 5281.0, 5423.0, 5530.0, 5332.0, 5635.0, 5699.0, 5357.0, 5690.0, 5429.0, 5415.0, 5692.0, 5409.0, 5702.0, 5362.0, 5286.0, 5447.0, 5381.0, 5321.0, 5611.0, 5449.0, 5463.0, 5269.0, 5338.0, 5721.0, 5603.0, 5391.0, 5383.0, 5559.0, 5312.0, 5583.0, 5677.0 (number of hits: 3)
2	5490	9	1	333	1	5449.0, 5268.0, 5562.0, 5547.0, 5551.0, 5321.0, 5591.0, 5376.0, 5339.0, 5479.0, 5536.0, 5353.0, 5414.0, 5492.0, 5580.0, 5254.0, 5307.0, 5724.0, 5497.0, 5486.0, 5627.0, 5304.0, 5440.0, 5324.0, 5420.0, 5332.0, 5692.0, 5322.0, 5630.0, 5670.0, 5352.0, 5377.0, 5555.0, 5487.0, 5509.0, 5355.0, 5543.0, 5690.0, 5710.0, 5315.0, 5338.0, 5434.0, 5460.0, 5607.0, 5384.0, 5500.0, 5668.0, 5567.0, 5646.0, 5396.0, 5633.0, 5705.0, 5662.0, 5522.0, 5560.0, 5453.0, 5718.0, 5367.0, 5474.0, 5596.0, 5451.0, 5582.0, 5696.0, 5303.0, 5361.0, 5295.0, 5558.0, 5675.0, 5585.0, 5715.0, 5671.0, 5264.0, 5629.0, 5691.0, 5506.0, 5257.0, 5507.0, 5471.0, 5256.0, 5424.0, 5698.0, 5575.0, 5513.0, 5375.0, 5686.0, 5619.0, 5284.0, 5437.0, 5277.0, 5649.0, 5579.0, 5402.0, 5523.0, 5626.0, 5364.0, 5641.0, 5684.0, 5289.0, 5489.0, 5625.0 (number of hits: 5)
3	5490	9	1	333	1	5639.0, 5260.0, 5609.0, 5399.0, 5461.0, 5652.0, 5612.0, 5555.0, 5550.0, 5638.0, 5509.0, 5590.0, 5704.0, 5566.0, 5264.0, 5360.0, 5397.0, 5332.0, 5337.0, 5670.0, 5645.0, 5413.0, 5694.0, 5342.0, 5312.0, 5557.0, 5435.0, 5266.0, 5610.0, 5711.0, 5592.0, 5407.0, 5480.0, 5485.0, 5278.0, 5489.0, 5643.0, 5430.0, 5401.0, 5265.0, 5387.0, 5718.0, 5308.0, 5299.0, 5287.0, 5721.0, 5298.0, 5334.0, 5419.0, 5689.0, 5594.0, 5355.0, 5268.0, 5675.0, 5439.0, 5563.0, 5323.0, 5702.0, 5424.0, 5396.0, 5696.0, 5321.0, 5605.0, 5307.0, 5616.0,

						5530.0, 5388.0, 5544.0, 5392.0, 5394.0, 5668.0, 5518.0, 5326.0, 5662.0, 5634.0, 5486.0, 5372.0, 5354.0, 5573.0, 5687.0, 5653.0, 5404.0, 5262.0, 5631.0, 5482.0, 5519.0, 5453.0, 5490.0, 5465.0, 5510.0, 5371.0, 5651.0, 5275.0, 5688.0, 5446.0, 5667.0, 5570.0, 5428.0, 5325.0, 5304.0 (number of hits: 6)
4	5490	9	1	333	1	5715.0, 5711.0, 5587.0, 5323.0, 5455.0, 5279.0, 5327.0, 5547.0, 5332.0, 5476.0, 5408.0, 5513.0, 5427.0, 5712.0, 5375.0, 5310.0, 5420.0, 5430.0, 5664.0, 5251.0, 5550.0, 5538.0, 5406.0, 5314.0, 5686.0, 5376.0, 5719.0, 5302.0, 5345.0, 5445.0, 5441.0, 5266.0, 5702.0, 5486.0, 5696.0, 5589.0, 5648.0, 5579.0, 5415.0, 5633.0, 5293.0, 5693.0, 5681.0, 5605.0, 5416.0, 5646.0, 5436.0, 5624.0, 5704.0, 5637.0, 5653.0, 5459.0, 5634.0, 5492.0, 5537.0, 5595.0, 5533.0, 5572.0, 5371.0, 5426.0, 5341.0, 5369.0, 5694.0, 5510.0, 5657.0, 5629.0, 5403.0, 5635.0, 5585.0, 5422.0, 5529.0, 5621.0, 5515.0, 5714.0, 5540.0, 5496.0, 5668.0, 5504.0, 5479.0, 5339.0, 5563.0, 5473.0, 5443.0, 5699.0, 5456.0, 5381.0, 5404.0, 5386.0, 5438.0, 5373.0, 5417.0, 5324.0, 5527.0, 5561.0, 5717.0, 5265.0, 5450.0, 5463.0, 5709.0, 5599.0 (number of hits: 3)
5	5490	9	1	333	0	0
6	5490	9	1	333	1	5319.0, 5666.0, 5523.0, 5642.0, 5705.0, 5270.0, 5336.0, 5411.0, 5511.0, 5366.0, 5260.0, 5490.0, 5551.0, 5434.0, 5694.0, 5345.0, 5266.0, 5368.0, 5267.0, 5395.0, 5278.0, 5588.0, 5285.0, 5263.0, 5445.0, 5344.0, 5547.0, 5577.0, 5289.0, 5543.0, 5500.0, 5650.0, 5257.0, 5629.0, 5531.0, 5435.0, 5413.0, 5681.0, 5520.0, 5486.0, 5444.0, 5721.0, 5638.0, 5358.0, 5255.0, 5463.0, 5396.0, 5517.0, 5574.0, 5538.0, 5452.0, 5703.0, 5711.0, 5401.0, 5407.0, 5426.0, 5669.0, 5337.0, 5381.0, 5594.0, 5623.0, 5291.0, 5656.0, 5618.0, 5404.0, 5466.0, 5621.0, 5497.0, 5651.0, 5410.0, 5307.0, 5457.0, 5537.0, 5343.0, 5259.0, 5338.0, 5679.0, 5564.0, 5297.0, 5339.0, 5579.0, 5416.0, 5332.0, 5680.0, 5528.0, 5719.0, 5346.0, 5664.0, 5542.0, 5608.0, 5274.0, 5422.0, 5269.0, 5326.0, 5572.0, 5275.0, 5534.0, 5493.0, 5606.0, 5555.0 (number of hits: 4)
7	5490	9	1	333	1	5555.0, 5621.0, 5570.0, 5355.0, 5284.0, 5709.0, 5578.0, 5341.0, 5332.0, 5423.0, 5254.0, 5478.0, 5616.0, 5595.0, 5323.0, 5529.0, 5474.0, 5324.0, 5594.0, 5305.0, 5604.0, 5567.0, 5540.0, 5485.0, 5288.0, 5437.0, 5345.0, 5694.0, 5636.0, 5322.0, 5659.0, 5681.0, 5588.0, 5422.0, 5348.0, 5391.0, 5498.0, 5449.0, 5271.0, 5414.0, 5660.0, 5340.0, 5511.0, 5320.0, 5429.0, 5321.0, 5364.0, 5560.0, 5376.0, 5665.0,

						5554.0, 5723.0, 5677.0, 5569.0, 5431.0, 5434.0, 5697.0, 5672.0, 5439.0, 5628.0, 5606.0, 5611.0, 5641.0, 5654.0, 5572.0, 5417.0, 5592.0, 5700.0, 5255.0, 5448.0, 5418.0, 5703.0, 5626.0, 5510.0, 5281.0, 5444.0, 5459.0, 5398.0, 5420.0, 5722.0, 5256.0, 5257.0, 5538.0, 5701.0, 5599.0, 5688.0, 5528.0, 5402.0, 5573.0, 5526.0, 5673.0, 5702.0, 5655.0, 5382.0, 5473.0, 5435.0, 5372.0, 5627.0, 5678.0, 5464.0 (number of hits: 2)
8	5490	9	1	333	1	5317.0, 5717.0, 5338.0, 5282.0, 5573.0, 5679.0, 5512.0, 5285.0, 5385.0, 5394.0, 5719.0, 5684.0, 5689.0, 5314.0, 5287.0, 5722.0, 5547.0, 5595.0, 5253.0, 5495.0, 5624.0, 5630.0, 5267.0, 5312.0, 5351.0, 5634.0, 5388.0, 5639.0, 5352.0, 5534.0, 5439.0, 5308.0, 5366.0, 5392.0, 5618.0, 5531.0, 5545.0, 5676.0, 5295.0, 5584.0, 5474.0, 5574.0, 5628.0, 5588.0, 5303.0, 5321.0, 5304.0, 5536.0, 5268.0, 5419.0, 5529.0, 5721.0, 5556.0, 5587.0, 5331.0, 5620.0, 5341.0, 5440.0, 5323.0, 5516.0, 5614.0, 5421.0, 5578.0, 5677.0, 5310.0, 5345.0, 5396.0, 5504.0, 5583.0, 5623.0, 5626.0, 5559.0, 5262.0, 5666.0, 5420.0, 5625.0, 5694.0, 5635.0, 5602.0, 5550.0, 5336.0, 5665.0, 5318.0, 5698.0, 5276.0, 5368.0, 5265.0, 5455.0, 5582.0, 5644.0, 5293.0, 5454.0, 5311.0, 5597.0, 5286.0, 5617.0, 5432.0, 5453.0, 5598.0, 5641.0 (number of hits: 1)
9	5490	9	1	333	1	5677.0, 5503.0, 5297.0, 5602.0, 5585.0, 5338.0, 5341.0, 5370.0, 5552.0, 5465.0, 5534.0, 5454.0, 5284.0, 5520.0, 5406.0, 5492.0, 5626.0, 5580.0, 5642.0, 5487.0, 5629.0, 5313.0, 5298.0, 5316.0, 5355.0, 5716.0, 5270.0, 5403.0, 5445.0, 5426.0, 5273.0, 5499.0, 5289.0, 5458.0, 5711.0, 5577.0, 5269.0, 5294.0, 5275.0, 5704.0, 5323.0, 5330.0, 5472.0, 5652.0, 5252.0, 5328.0, 5621.0, 5683.0, 5453.0, 5570.0, 5325.0, 5381.0, 5322.0, 5584.0, 5600.0, 5714.0, 5660.0, 5663.0, 5267.0, 5388.0, 5581.0, 5306.0, 5590.0, 5638.0, 5365.0, 5475.0, 5321.0, 5299.0, 5659.0, 5356.0, 5592.0, 5444.0, 5480.0, 5603.0, 5309.0, 5422.0, 5521.0, 5686.0, 5658.0, 5441.0, 5468.0, 5706.0, 5428.0, 5469.0, 5574.0, 5401.0, 5481.0, 5411.0, 5680.0, 5526.0, 5408.0, 5443.0, 5525.0, 5519.0, 5655.0, 5633.0, 5463.0, 5397.0, 5611.0, 5643.0 (number of hits: 5)
10	5500	9	1	333	1	5534.0, 5656.0, 5409.0, 5510.0, 5684.0, 5583.0, 5412.0, 5515.0, 5470.0, 5518.0, 5441.0, 5668.0, 5426.0, 5445.0, 5344.0, 5462.0, 5533.0, 5272.0, 5629.0, 5358.0, 5567.0, 5484.0, 5692.0, 5525.0, 5458.0, 5594.0, 5279.0, 5529.0, 5396.0, 5632.0, 5356.0, 5681.0, 5474.0, 5697.0, 5679.0, 5569.0, 5630.0, 5705.0, 5516.0, 5574.0,

						5612.0, 5585.0, 5275.0, 5500.0, 5564.0, 5324.0, 5267.0, 5294.0, 5274.0, 5375.0, 5384.0, 5475.0, 5345.0, 5481.0, 5566.0, 5598.0, 5339.0, 5346.0, 5476.0, 5429.0, 5665.0, 5318.0, 5386.0, 5587.0, 5505.0, 5571.0, 5472.0, 5405.0, 5626.0, 5453.0, 5303.0, 5385.0, 5331.0, 5404.0, 5671.0, 5645.0, 5264.0, 5362.0, 5383.0, 5399.0, 5492.0, 5636.0, 5261.0, 5486.0, 5723.0, 5538.0, 5545.0, 5473.0, 5327.0, 5289.0, 5619.0, 5265.0, 5369.0, 5353.0, 5398.0, 5418.0, 5693.0, 5355.0, 5440.0, 5406.0 (number of hits: 3)
11	5500	9	1	333	1	5388.0, 5497.0, 5530.0, 5710.0, 5686.0, 5302.0, 5430.0, 5570.0, 5705.0, 5619.0, 5546.0, 5555.0, 5708.0, 5628.0, 5601.0, 5309.0, 5288.0, 5595.0, 5606.0, 5494.0, 5666.0, 5655.0, 5279.0, 5319.0, 5538.0, 5278.0, 5498.0, 5348.0, 5420.0, 5305.0, 5260.0, 5270.0, 5533.0, 5657.0, 5407.0, 5589.0, 5475.0, 5645.0, 5678.0, 5525.0, 5622.0, 5518.0, 5667.0, 5699.0, 5722.0, 5607.0, 5251.0, 5311.0, 5676.0, 5573.0, 5359.0, 5287.0, 5291.0, 5317.0, 5720.0, 5397.0, 5341.0, 5613.0, 5536.0, 5266.0, 5653.0, 5303.0, 5385.0, 5652.0, 5378.0, 5387.0, 5615.0, 5660.0, 5553.0, 5561.0, 5691.0, 5597.0, 5695.0, 5515.0, 5321.0, 5598.0, 5702.0, 5318.0, 5344.0, 5298.0, 5612.0, 5438.0, 5455.0, 5289.0, 5393.0, 5354.0, 5482.0, 5586.0, 5401.0, 5332.0, 5499.0, 5425.0, 5647.0, 5532.0, 5683.0, 5608.0, 5621.0, 5588.0, 5593.0, 5591.0 (number of hits: 4)
12	5500	9	1	333	1	5373.0, 5259.0, 5302.0, 5602.0, 5541.0, 5611.0, 5444.0, 5378.0, 5364.0, 5389.0, 5567.0, 5685.0, 5645.0, 5641.0, 5436.0, 5403.0, 5401.0, 5590.0, 5496.0, 5265.0, 5681.0, 5588.0, 5717.0, 5420.0, 5385.0, 5293.0, 5327.0, 5369.0, 5405.0, 5608.0, 5612.0, 5625.0, 5620.0, 5437.0, 5664.0, 5391.0, 5694.0, 5288.0, 5525.0, 5709.0, 5409.0, 5301.0, 5660.0, 5633.0, 5276.0, 5507.0, 5475.0, 5323.0, 5404.0, 5640.0, 5631.0, 5583.0, 5572.0, 5484.0, 5698.0, 5443.0, 5693.0, 5565.0, 5600.0, 5419.0, 5716.0, 5534.0, 5561.0, 5603.0, 5553.0, 5677.0, 5596.0, 5466.0, 5453.0, 5571.0, 5351.0, 5280.0, 5597.0, 5706.0, 5615.0, 5545.0, 5671.0, 5509.0, 5333.0, 5291.0, 5393.0, 5312.0, 5556.0, 5512.0, 5376.0, 5471.0, 5646.0, 5535.0, 5584.0, 5287.0, 5647.0, 5721.0, 5366.0, 5342.0, 5295.0, 5486.0, 5714.0, 5425.0, 5278.0, 5395.0 (number of hits: 3)
13	5500	9	1	333	1	5442.0, 5425.0, 5525.0, 5275.0, 5690.0, 5683.0, 5502.0, 5460.0, 5434.0, 5639.0, 5412.0, 5599.0, 5495.0, 5711.0, 5567.0, 5589.0, 5593.0, 5445.0, 5300.0, 5268.0, 5626.0, 5429.0, 5710.0, 5521.0, 5327.0, 5313.0, 5355.0, 5627.0, 5636.0, 5585.0,

						5624.0, 5717.0, 5285.0, 5524.0, 5431.0, 5556.0, 5440.0, 5259.0, 5494.0, 5409.0, 5314.0, 5681.0, 5250.0, 5549.0, 5638.0, 5408.0, 5288.0, 5329.0, 5546.0, 5653.0, 5659.0, 5504.0, 5662.0, 5375.0, 5664.0, 5374.0, 5706.0, 5650.0, 5559.0, 5581.0, 5324.0, 5616.0, 5298.0, 5295.0, 5660.0, 5334.0, 5678.0, 5383.0, 5649.0, 5344.0, 5614.0, 5325.0, 5604.0, 5505.0, 5475.0, 5579.0, 5254.0, 5565.0, 5573.0, 5545.0, 5407.0, 5256.0, 5361.0, 5266.0, 5612.0, 5723.0, 5420.0, 5472.0, 5446.0, 5656.0, 5705.0, 5428.0, 5477.0, 5571.0, 5369.0, 5608.0, 5391.0, 5372.0, 5297.0, 5560.0 (number of hits: 5)
14	5500	9	1	333	1	5485.0, 5526.0, 5648.0, 5618.0, 5460.0, 5371.0, 5315.0, 5358.0, 5584.0, 5335.0, 5536.0, 5331.0, 5275.0, 5683.0, 5251.0, 5666.0, 5512.0, 5721.0, 5256.0, 5605.0, 5559.0, 5291.0, 5658.0, 5300.0, 5452.0, 5457.0, 5279.0, 5706.0, 5364.0, 5646.0, 5575.0, 5422.0, 5571.0, 5637.0, 5664.0, 5308.0, 5645.0, 5528.0, 5599.0, 5318.0, 5634.0, 5662.0, 5374.0, 5356.0, 5522.0, 5564.0, 5351.0, 5412.0, 5500.0, 5668.0, 5578.0, 5322.0, 5429.0, 5594.0, 5458.0, 5622.0, 5372.0, 5292.0, 5560.0, 5378.0, 5501.0, 5319.0, 5438.0, 5470.0, 5632.0, 5469.0, 5556.0, 5562.0, 5707.0, 5518.0, 5361.0, 5697.0, 5720.0, 5547.0, 5565.0, 5313.0, 5494.0, 5561.0, 5327.0, 5711.0, 5382.0, 5505.0, 5409.0, 5686.0, 5442.0, 5441.0, 5581.0, 5456.0, 5691.0, 5489.0, 5454.0, 5674.0, 5483.0, 5398.0, 5340.0, 5682.0, 5395.0, 5684.0, 5466.0, 5557.0 (number of hits: 4)
15	5500	9	1	333	1	5503.0, 5555.0, 5531.0, 5279.0, 5620.0, 5723.0, 5493.0, 5530.0, 5602.0, 5376.0, 5372.0, 5476.0, 5631.0, 5597.0, 5649.0, 5294.0, 5627.0, 5486.0, 5425.0, 5463.0, 5452.0, 5509.0, 5451.0, 5459.0, 5475.0, 5381.0, 5716.0, 5332.0, 5549.0, 5292.0, 5271.0, 5672.0, 5704.0, 5378.0, 5623.0, 5516.0, 5582.0, 5328.0, 5512.0, 5281.0, 5406.0, 5654.0, 5284.0, 5610.0, 5590.0, 5505.0, 5518.0, 5579.0, 5450.0, 5431.0, 5349.0, 5439.0, 5593.0, 5699.0, 5532.0, 5574.0, 5282.0, 5656.0, 5709.0, 5302.0, 5267.0, 5461.0, 5323.0, 5605.0, 5714.0, 5436.0, 5696.0, 5607.0, 5443.0, 5313.0, 5483.0, 5658.0, 5437.0, 5474.0, 5364.0, 5266.0, 5456.0, 5510.0, 5316.0, 5417.0, 5715.0, 5558.0, 5433.0, 5321.0, 5416.0, 5283.0, 5366.0, 5557.0, 5290.0, 5492.0, 5255.0, 5413.0, 5681.0, 5675.0, 5551.0, 5563.0, 5464.0, 5371.0, 5428.0, 5508.0 (number of hits: 6)
16	5500	9	1	333	1	5611.0, 5305.0, 5556.0, 5492.0, 5507.0, 5691.0, 5499.0, 5280.0, 5287.0, 5327.0, 5385.0, 5533.0, 5593.0, 5530.0, 5535.0, 5346.0, 5426.0, 5694.0, 5314.0, 5575.0,

						5672.0, 5414.0, 5275.0, 5595.0, 5528.0, 5721.0, 5261.0, 5474.0, 5549.0, 5582.0, 5439.0, 5473.0, 5254.0, 5329.0, 5538.0, 5626.0, 5713.0, 5552.0, 5666.0, 5714.0, 5322.0, 5584.0, 5529.0, 5303.0, 5606.0, 5433.0, 5382.0, 5665.0, 5257.0, 5717.0, 5300.0, 5596.0, 5429.0, 5523.0, 5693.0, 5581.0, 5524.0, 5467.0, 5485.0, 5444.0, 5281.0, 5290.0, 5640.0, 5471.0, 5271.0, 5491.0, 5544.0, 5651.0, 5357.0, 5707.0, 5662.0, 5354.0, 5619.0, 5509.0, 5446.0, 5540.0, 5398.0, 5310.0, 5563.0, 5539.0, 5400.0, 5333.0, 5343.0, 5347.0, 5562.0, 5679.0, 5458.0, 5580.0, 5518.0, 5636.0, 5643.0, 5600.0, 5424.0, 5637.0, 5457.0, 5337.0, 5661.0, 5390.0, 5574.0, 5328.0 (number of hits: 5)
17	5500	9	1	333	1	5427.0, 5683.0, 5368.0, 5439.0, 5693.0, 5344.0, 5302.0, 5516.0, 5489.0, 5517.0, 5331.0, 5482.0, 5413.0, 5438.0, 5485.0, 5694.0, 5668.0, 5582.0, 5691.0, 5545.0, 5520.0, 5346.0, 5535.0, 5334.0, 5627.0, 5446.0, 5557.0, 5542.0, 5362.0, 5251.0, 5395.0, 5667.0, 5589.0, 5546.0, 5523.0, 5340.0, 5486.0, 5505.0, 5715.0, 5632.0, 5531.0, 5456.0, 5337.0, 5409.0, 5254.0, 5560.0, 5351.0, 5510.0, 5414.0, 5387.0, 5307.0, 5634.0, 5706.0, 5569.0, 5512.0, 5345.0, 5460.0, 5441.0, 5584.0, 5612.0, 5336.0, 5540.0, 5501.0, 5575.0, 5463.0, 5541.0, 5445.0, 5659.0, 5432.0, 5493.0, 5418.0, 5585.0, 5312.0, 5335.0, 5695.0, 5611.0, 5329.0, 5328.0, 5477.0, 5697.0, 5271.0, 5676.0, 5689.0, 5258.0, 5623.0, 5526.0, 5296.0, 5553.0, 5626.0, 5433.0, 5396.0, 5555.0, 5682.0, 5624.0, 5324.0, 5648.0, 5380.0, 5419.0, 5339.0, 5644.0 (number of hits: 3)
18	5500	9	1	333	1	5452.0, 5416.0, 5331.0, 5665.0, 5406.0, 5642.0, 5694.0, 5356.0, 5659.0, 5291.0, 5307.0, 5460.0, 5504.0, 5378.0, 5690.0, 5420.0, 5398.0, 5712.0, 5455.0, 5479.0, 5351.0, 5570.0, 5687.0, 5447.0, 5685.0, 5519.0, 5635.0, 5696.0, 5677.0, 5621.0, 5593.0, 5397.0, 5349.0, 5306.0, 5298.0, 5619.0, 5424.0, 5281.0, 5564.0, 5537.0, 5390.0, 5567.0, 5676.0, 5437.0, 5606.0, 5641.0, 5290.0, 5352.0, 5444.0, 5329.0, 5585.0, 5395.0, 5561.0, 5314.0, 5614.0, 5319.0, 5716.0, 5326.0, 5622.0, 5333.0, 5492.0, 5272.0, 5309.0, 5463.0, 5253.0, 5626.0, 5318.0, 5464.0, 5340.0, 5320.0, 5433.0, 5524.0, 5392.0, 5322.0, 5569.0, 5560.0, 5350.0, 5367.0, 5412.0, 5353.0, 5662.0, 5348.0, 5581.0, 5510.0, 5266.0, 5372.0, 5526.0, 5336.0, 5582.0, 5299.0, 5598.0, 5609.0, 5448.0, 5618.0, 5364.0, 5506.0, 5254.0, 5713.0, 5260.0, 5467.0 (number of hits: 3)
19	5500	9	1	333	1	5375.0, 5597.0, 5520.0, 5709.0, 5718.0, 5311.0, 5419.0, 5457.0, 5253.0, 5262.0,

						5619.0, 5519.0, 5363.0, 5693.0, 5515.0, 5321.0, 5638.0, 5393.0, 5275.0, 5562.0, 5476.0, 5392.0, 5497.0, 5324.0, 5604.0, 5310.0, 5317.0, 5438.0, 5415.0, 5405.0, 5509.0, 5376.0, 5549.0, 5401.0, 5300.0, 5649.0, 5589.0, 5274.0, 5368.0, 5445.0, 5630.0, 5488.0, 5386.0, 5547.0, 5342.0, 5502.0, 5470.0, 5666.0, 5655.0, 5318.0, 5426.0, 5338.0, 5606.0, 5505.0, 5609.0, 5489.0, 5674.0, 5294.0, 5522.0, 5487.0, 5684.0, 5397.0, 5722.0, 5492.0, 5301.0, 5596.0, 5610.0, 5306.0, 5493.0, 5555.0, 5287.0, 5691.0, 5517.0, 5595.0, 5336.0, 5473.0, 5257.0, 5431.0, 5548.0, 5322.0, 5706.0, 5332.0, 5654.0, 5639.0, 5721.0, 5698.0, 5557.0, 5264.0, 5507.0, 5390.0, 5641.0, 5658.0, 5447.0, 5554.0, 5633.0, 5365.0, 5704.0, 5404.0, 5600.0, 5590.0 (number of hits: 7)
20	5500	9	1	333	1	5511.0, 5478.0, 5610.0, 5532.0, 5273.0, 5410.0, 5341.0, 5475.0, 5543.0, 5252.0, 5258.0, 5396.0, 5491.0, 5715.0, 5471.0, 5297.0, 5677.0, 5294.0, 5664.0, 5642.0, 5504.0, 5413.0, 5457.0, 5336.0, 5257.0, 5276.0, 5284.0, 5700.0, 5289.0, 5476.0, 5691.0, 5417.0, 5592.0, 5331.0, 5707.0, 5709.0, 5472.0, 5412.0, 5622.0, 5600.0, 5468.0, 5390.0, 5292.0, 5459.0, 5641.0, 5567.0, 5251.0, 5378.0, 5342.0, 5313.0, 5531.0, 5643.0, 5632.0, 5357.0, 5449.0, 5708.0, 5665.0, 5456.0, 5572.0, 5304.0, 5571.0, 5566.0, 5421.0, 5501.0, 5505.0, 5674.0, 5335.0, 5666.0, 5503.0, 5486.0, 5405.0, 5373.0, 5375.0, 5285.0, 5699.0, 5500.0, 5710.0, 5634.0, 5584.0, 5263.0, 5675.0, 5447.0, 5524.0, 5603.0, 5576.0, 5484.0, 5586.0, 5559.0, 5262.0, 5433.0, 5470.0, 5323.0, 5508.0, 5611.0, 5411.0, 5577.0, 5687.0, 5538.0, 5555.0, 5564.0 (number of hits: 7)
21	5510	9	1	333	1	5473.0, 5500.0, 5280.0, 5504.0, 5428.0, 5506.0, 5577.0, 5434.0, 5319.0, 5560.0, 5351.0, 5607.0, 5555.0, 5452.0, 5356.0, 5671.0, 5478.0, 5636.0, 5709.0, 5406.0, 5681.0, 5340.0, 5308.0, 5541.0, 5429.0, 5673.0, 5694.0, 5588.0, 5559.0, 5574.0, 5414.0, 5305.0, 5682.0, 5462.0, 5603.0, 5532.0, 5498.0, 5528.0, 5539.0, 5515.0, 5645.0, 5369.0, 5690.0, 5463.0, 5496.0, 5281.0, 5609.0, 5456.0, 5550.0, 5639.0, 5397.0, 5381.0, 5721.0, 5261.0, 5435.0, 5604.0, 5567.0, 5278.0, 5255.0, 5514.0, 5458.0, 5354.0, 5615.0, 5461.0, 5706.0, 5676.0, 5306.0, 5426.0, 5509.0, 5366.0, 5584.0, 5339.0, 5370.0, 5358.0, 5591.0, 5626.0, 5611.0, 5454.0, 5622.0, 5512.0, 5598.0, 5364.0, 5347.0, 5707.0, 5433.0, 5469.0, 5660.0, 5392.0, 5479.0, 5617.0, 5497.0, 5411.0, 5326.0, 5670.0, 5575.0, 5266.0, 5710.0, 5714.0, 5593.0, 5323.0 (number of hits: 7)

22	5510	9	1	333	1	5543.0, 5277.0, 5523.0, 5452.0, 5393.0, 5407.0, 5587.0, 5376.0, 5652.0, 5689.0, 5540.0, 5375.0, 5663.0, 5621.0, 5409.0, 5287.0, 5641.0, 5265.0, 5481.0, 5305.0, 5476.0, 5487.0, 5497.0, 5668.0, 5504.0, 5496.0, 5471.0, 5370.0, 5511.0, 5303.0, 5440.0, 5454.0, 5425.0, 5681.0, 5567.0, 5686.0, 5677.0, 5401.0, 5323.0, 5718.0, 5606.0, 5346.0, 5593.0, 5405.0, 5684.0, 5555.0, 5671.0, 5325.0, 5572.0, 5601.0, 5381.0, 5335.0, 5576.0, 5392.0, 5398.0, 5333.0, 5377.0, 5427.0, 5433.0, 5358.0, 5655.0, 5670.0, 5404.0, 5340.0, 5514.0, 5528.0, 5597.0, 5442.0, 5260.0, 5605.0, 5336.0, 5414.0, 5590.0, 5324.0, 5490.0, 5545.0, 5418.0, 5688.0, 5402.0, 5259.0, 5470.0, 5515.0, 5558.0, 5695.0, 5610.0, 5374.0, 5722.0, 5316.0, 5480.0, 5614.0, 5430.0, 5395.0, 5716.0, 5261.0, 5284.0, 5327.0, 5342.0, 5502.0, 5569.0, 5457.0 (number of hits: 5)
23	5510	9	1	333	1	5569.0, 5373.0, 5570.0, 5507.0, 5431.0, 5387.0, 5701.0, 5439.0, 5418.0, 5441.0, 5694.0, 5666.0, 5392.0, 5343.0, 5296.0, 5419.0, 5270.0, 5532.0, 5258.0, 5347.0, 5413.0, 5631.0, 5591.0, 5553.0, 5664.0, 5561.0, 5320.0, 5676.0, 5586.0, 5682.0, 5253.0, 5588.0, 5571.0, 5528.0, 5289.0, 5684.0, 5399.0, 5317.0, 5706.0, 5301.0, 5375.0, 5309.0, 5295.0, 5515.0, 5613.0, 5702.0, 5674.0, 5500.0, 5585.0, 5652.0, 5288.0, 5327.0, 5691.0, 5265.0, 5473.0, 5620.0, 5493.0, 5346.0, 5300.0, 5305.0, 5313.0, 5654.0, 5372.0, 5718.0, 5546.0, 5435.0, 5642.0, 5560.0, 5428.0, 5323.0, 5453.0, 5582.0, 5378.0, 5592.0, 5589.0, 5610.0, 5426.0, 5693.0, 5526.0, 5444.0, 5358.0, 5447.0, 5388.0, 5544.0, 5716.0, 5264.0, 5724.0, 5322.0, 5648.0, 5351.0, 5695.0, 5640.0, 5605.0, 5374.0, 5403.0, 5263.0, 5462.0, 5579.0, 5711.0, 5486.0 (number of hits: 3)
24	5510	9	1	333	1	5565.0, 5286.0, 5300.0, 5617.0, 5482.0, 5658.0, 5627.0, 5435.0, 5403.0, 5656.0, 5325.0, 5254.0, 5467.0, 5385.0, 5419.0, 5708.0, 5412.0, 5711.0, 5525.0, 5626.0, 5439.0, 5615.0, 5442.0, 5597.0, 5407.0, 5319.0, 5477.0, 5256.0, 5509.0, 5534.0, 5642.0, 5571.0, 5341.0, 5270.0, 5552.0, 5496.0, 5721.0, 5452.0, 5257.0, 5447.0, 5469.0, 5543.0, 5474.0, 5268.0, 5625.0, 5288.0, 5574.0, 5715.0, 5674.0, 5497.0, 5411.0, 5276.0, 5545.0, 5369.0, 5320.0, 5527.0, 5573.0, 5557.0, 5591.0, 5275.0, 5703.0, 5518.0, 5453.0, 5329.0, 5380.0, 5676.0, 5520.0, 5365.0, 5458.0, 5547.0, 5438.0, 5421.0, 5428.0, 5541.0, 5279.0, 5548.0, 5362.0, 5635.0, 5682.0, 5448.0, 5340.0, 5258.0, 5367.0, 5692.0, 5396.0, 5508.0, 5423.0, 5422.0, 5293.0, 5360.0, 5515.0, 5333.0, 5688.0, 5539.0, 5695.0,

						5463.0, 5636.0, 5610.0, 5372.0, 5705.0 (number of hits: 4)
25	5510	9	1	333	1	5345.0, 5518.0, 5635.0, 5339.0, 5452.0, 5463.0, 5300.0, 5654.0, 5438.0, 5598.0, 5633.0, 5265.0, 5550.0, 5460.0, 5536.0, 5449.0, 5365.0, 5326.0, 5657.0, 5542.0, 5533.0, 5677.0, 5472.0, 5535.0, 5348.0, 5586.0, 5681.0, 5541.0, 5477.0, 5410.0, 5610.0, 5704.0, 5337.0, 5686.0, 5378.0, 5696.0, 5444.0, 5396.0, 5489.0, 5668.0, 5342.0, 5303.0, 5252.0, 5534.0, 5389.0, 5575.0, 5432.0, 5262.0, 5379.0, 5355.0, 5488.0, 5613.0, 5486.0, 5304.0, 5554.0, 5285.0, 5294.0, 5407.0, 5510.0, 5568.0, 5500.0, 5259.0, 5465.0, 5714.0, 5402.0, 5587.0, 5484.0, 5614.0, 5282.0, 5440.0, 5456.0, 5386.0, 5418.0, 5395.0, 5358.0, 5329.0, 5273.0, 5448.0, 5370.0, 5494.0, 5688.0, 5380.0, 5647.0, 5287.0, 5579.0, 5576.0, 5615.0, 5320.0, 5655.0, 5653.0, 5321.0, 5644.0, 5253.0, 5597.0, 5367.0, 5254.0, 5260.0, 5385.0, 5308.0, 5309.0 (number of hits: 3)
26	5510	9	1	333	1	5484.0, 5423.0, 5410.0, 5576.0, 5259.0, 5321.0, 5432.0, 5434.0, 5260.0, 5384.0, 5687.0, 5559.0, 5616.0, 5593.0, 5529.0, 5254.0, 5252.0, 5505.0, 5325.0, 5418.0, 5389.0, 5492.0, 5367.0, 5445.0, 5267.0, 5554.0, 5409.0, 5359.0, 5393.0, 5721.0, 5403.0, 5355.0, 5365.0, 5292.0, 5253.0, 5313.0, 5704.0, 5430.0, 5519.0, 5298.0, 5633.0, 5544.0, 5283.0, 5372.0, 5711.0, 5489.0, 5256.0, 5477.0, 5345.0, 5628.0, 5579.0, 5285.0, 5603.0, 5581.0, 5480.0, 5470.0, 5289.0, 5428.0, 5640.0, 5702.0, 5673.0, 5326.0, 5339.0, 5295.0, 5315.0, 5390.0, 5378.0, 5366.0, 5590.0, 5572.0, 5422.0, 5281.0, 5683.0, 5691.0, 5615.0, 5667.0, 5429.0, 5659.0, 5621.0, 5413.0, 5439.0, 5637.0, 5504.0, 5466.0, 5380.0, 5703.0, 5437.0, 5601.0, 5671.0, 5307.0, 5669.0, 5642.0, 5528.0, 5518.0, 5513.0, 5262.0, 5675.0, 5627.0, 5609.0, 5333.0 (number of hits: 5)
27	5510	9	1	333	1	5670.0, 5719.0, 5278.0, 5268.0, 5691.0, 5426.0, 5411.0, 5415.0, 5483.0, 5458.0, 5533.0, 5391.0, 5636.0, 5502.0, 5314.0, 5369.0, 5276.0, 5265.0, 5671.0, 5696.0, 5707.0, 5323.0, 5379.0, 5467.0, 5360.0, 5271.0, 5267.0, 5482.0, 5290.0, 5325.0, 5384.0, 5292.0, 5295.0, 5575.0, 5493.0, 5589.0, 5673.0, 5453.0, 5338.0, 5450.0, 5590.0, 5612.0, 5468.0, 5262.0, 5461.0, 5350.0, 5569.0, 5396.0, 5273.0, 5630.0, 5260.0, 5462.0, 5495.0, 5587.0, 5343.0, 5291.0, 5286.0, 5716.0, 5300.0, 5660.0, 5304.0, 5487.0, 5353.0, 5488.0, 5476.0, 5457.0, 5393.0, 5527.0, 5490.0, 5407.0, 5626.0, 5579.0, 5563.0, 5649.0, 5523.0, 5718.0, 5508.0, 5395.0, 5687.0, 5423.0, 5470.0, 5251.0, 5544.0, 5619.0, 5683.0,

						5372.0, 5603.0, 5609.0, 5684.0, 5317.0, 5549.0, 5637.0, 5311.0, 5351.0, 5511.0, 5648.0, 5477.0, 5534.0, 5437.0, 5675.0 (number of hits: 3)
28	5510	9	1	333	1	5358.0, 5652.0, 5398.0, 5437.0, 5317.0, 5572.0, 5270.0, 5489.0, 5296.0, 5568.0, 5370.0, 5547.0, 5338.0, 5550.0, 5309.0, 5701.0, 5534.0, 5385.0, 5362.0, 5520.0, 5642.0, 5378.0, 5711.0, 5702.0, 5355.0, 5455.0, 5600.0, 5599.0, 5564.0, 5602.0, 5544.0, 5634.0, 5278.0, 5513.0, 5545.0, 5281.0, 5692.0, 5459.0, 5606.0, 5648.0, 5383.0, 5565.0, 5633.0, 5533.0, 5423.0, 5567.0, 5353.0, 5676.0, 5365.0, 5430.0, 5616.0, 5348.0, 5446.0, 5433.0, 5306.0, 5452.0, 5626.0, 5609.0, 5569.0, 5571.0, 5635.0, 5557.0, 5563.0, 5376.0, 5371.0, 5432.0, 5436.0, 5603.0, 5441.0, 5695.0, 5418.0, 5293.0, 5617.0, 5456.0, 5646.0, 5722.0, 5305.0, 5592.0, 5476.0, 5538.0, 5691.0, 5553.0, 5328.0, 5690.0, 5651.0, 5661.0, 5315.0, 5356.0, 5639.0, 5516.0, 5671.0, 5660.0, 5322.0, 5466.0, 5677.0, 5537.0, 5474.0, 5576.0, 5391.0, 5665.0 (number of hits: 2)
29	5510	9	1	333	1	5358.0, 5485.0, 5464.0, 5717.0, 5406.0, 5562.0, 5399.0, 5692.0, 5391.0, 5324.0, 5405.0, 5718.0, 5642.0, 5506.0, 5473.0, 5669.0, 5448.0, 5430.0, 5587.0, 5474.0, 5374.0, 5646.0, 5570.0, 5625.0, 5476.0, 5609.0, 5418.0, 5683.0, 5467.0, 5275.0, 5539.0, 5337.0, 5384.0, 5375.0, 5413.0, 5398.0, 5457.0, 5674.0, 5518.0, 5486.0, 5447.0, 5645.0, 5522.0, 5346.0, 5336.0, 5623.0, 5658.0, 5676.0, 5688.0, 5255.0, 5571.0, 5515.0, 5668.0, 5514.0, 5533.0, 5580.0, 5578.0, 5341.0, 5723.0, 5633.0, 5531.0, 5390.0, 5377.0, 5428.0, 5696.0, 5378.0, 5433.0, 5624.0, 5307.0, 5665.0, 5565.0, 5407.0, 5472.0, 5351.0, 5343.0, 5699.0, 5611.0, 5359.0, 5329.0, 5279.0, 5548.0, 5328.0, 5513.0, 5310.0, 5438.0, 5389.0, 5687.0, 5345.0, 5613.0, 5395.0, 5644.0, 5383.0, 5543.0, 5284.0, 5347.0, 5605.0, 5321.0, 5519.0, 5593.0, 5452.0 (number of hits: 6)
30	5510	9	1	333	1	5434.0, 5481.0, 5407.0, 5367.0, 5534.0, 5347.0, 5384.0, 5499.0, 5270.0, 5441.0, 5444.0, 5280.0, 5412.0, 5506.0, 5368.0, 5701.0, 5322.0, 5650.0, 5350.0, 5537.0, 5707.0, 5489.0, 5677.0, 5709.0, 5271.0, 5479.0, 5297.0, 5513.0, 5265.0, 5637.0, 5457.0, 5428.0, 5286.0, 5653.0, 5420.0, 5358.0, 5712.0, 5289.0, 5552.0, 5478.0, 5646.0, 5293.0, 5507.0, 5688.0, 5579.0, 5626.0, 5260.0, 5631.0, 5281.0, 5349.0, 5623.0, 5702.0, 5545.0, 5344.0, 5255.0, 5494.0, 5635.0, 5624.0, 5309.0, 5353.0, 5307.0, 5704.0, 5590.0, 5683.0, 5263.0, 5711.0, 5529.0, 5572.0, 5392.0, 5715.0, 5535.0, 5630.0, 5295.0, 5345.0, 5314.0,

						5492.0, 5250.0, 5388.0, 5332.0, 5594.0, 5291.0, 5649.0, 5520.0, 5490.0, 5324.0, 5690.0, 5603.0, 5595.0, 5497.0, 5502.0, 5393.0, 5611.0, 5551.0, 5693.0, 5577.0, 5556.0, 5326.0, 5627.0, 5287.0, 5656.0 (number of hits: 4)
--	--	--	--	--	--	--

A.2 40 MHz Bandwidth @ 5510 MHz

Table-1A/1B Radar Type 1A/1B Statistical Performance

Trial #	Fc (MHz)	Pulse/Burst	Pulse Width (µS)	PRI (µs)	Detection (1:yes; 0:no)
1	5490	65	1	818	1
2	5490	78	1	678	1
3	5490	72	1	738	1
4	5490	57	1	938	1
5	5490	95	1	558	1
6	5510	89	1	598	1
7	5510	83	1	638	1
8	5510	63	1	838	1
9	5510	76	1	698	1
10	5510	81	1	658	1
11	5530	70	1	758	1
12	5530	68	1	778	1
13	5530	67	1	798	1
14	5530	92	1	578	1
15	5530	86	1	618	1
16	5490	66	1	806	1
17	5490	22	1	2451	1
18	5490	33	1	1631	1
19	5490	21	1	2549	1
20	5490	101	1	523	1
21	5510	33	1	1627	1
22	5510	25	1	2137	1
23	5510	30	1	1768	1
24	5510	24	1	2294	1
25	5510	74	1	721	1
26	5530	59	1	900	1
27	5530	19	1	2815	0
28	5530	23	1	2298	1
29	5530	28	1	1934	1
30	5530	66	1	800	1
Detection Percentage: 96.67 % (>60%)					

Table-2 Radar Type 2 Statistical Performance

Trial #	Fc (MHz)	Pulse/Burst	Pulse Width (μ S)	PRI (μ s)	Detection (1:yes; 0:no)
1	5490	23	2.3	152	1
2	5490	26	2.4	229	1
3	5490	25	1.1	192	1
4	5490	24	2.9	155	1
5	5490	24	3.7	186	1
6	5490	23	4	158	1
7	5490	28	1.9	155	1
8	5490	23	3.3	193	1
9	5490	26	3.1	210	1
10	5490	26	1.7	155	1
11	5510	24	4.1	179	1
12	5510	26	3.2	224	1
13	5510	23	1.7	177	1
14	5510	29	4.1	184	1
15	5510	28	3.2	162	1
16	5510	26	4	174	1
17	5510	23	2.5	163	1
18	5510	24	4.4	210	1
19	5510	23	2.1	170	1
20	5510	28	3.1	228	1
21	5530	26	4	190	1
22	5530	27	3.4	160	1
23	5530	26	3.7	198	1
24	5530	24	2.8	169	1
25	5530	28	4.9	173	1
26	5530	26	3.2	194	1
27	5530	29	4.3	187	1
28	5530	25	1.3	182	1
29	5530	26	3.9	195	1
30	5530	25	3.1	186	1
Detection Percentage: 100 % (>60%)					

Table-3 Radar Type 3 Statistical Performance

Trial #	Fc (MHz)	Pulse/Burst	Pulse Width (μ S)	PRI (μ s)	Detection (1:yes; 0:no)
1	5490	18	8.7	483	1
2	5490	17	7	366	1
3	5490	17	7.6	435	1
4	5490	17	7	451	1
5	5490	16	6.3	229	1
6	5490	16	7.2	451	1
7	5490	18	7.9	200	1
8	5490	16	6	331	1
9	5490	16	7.3	357	1
10	5490	18	6.5	490	1
11	5510	18	7.4	484	1
12	5510	16	8.5	370	1
13	5510	16	7.3	212	1
14	5510	18	6.4	285	1
15	5510	17	9.4	429	1
16	5510	17	8	274	1
17	5510	17	7.9	403	1
18	5510	17	9.6	279	1
19	5510	18	8.9	329	1
20	5510	18	7.7	403	1
21	5530	17	6.5	215	1
22	5530	17	6.5	282	1
23	5530	17	6.5	437	1
24	5530	18	6.7	389	1
25	5530	18	7.1	306	1
26	5530	17	6.2	486	1
27	5530	16	9	365	1
28	5530	18	6.7	334	1
29	5530	17	6.2	335	1
30	5530	16	9.1	279	1
Detection Percentage: 100 % (>60%)					

Table-4 Radar Type 4 Statistical Performance

Trial #	Fc (MHz)	Pulse/Burst	Pulse Width (μS)	PRI (μs)	Detection (1:yes; 0:no)
1	5490	13	12.8	203	1
2	5490	12	19.4	263	1
3	5490	13	18.2	469	1
4	5490	12	15.1	384	1
5	5490	13	12.1	496	1
6	5490	13	11.1	452	1
7	5490	14	11.4	396	1
8	5490	15	12.2	429	1
9	5490	13	13	297	1
10	5490	13	18.2	280	1
11	5510	13	12.2	308	1
12	5510	15	11.6	318	1
13	5510	13	18.4	216	1
14	5510	12	17.8	477	1
15	5510	13	19.8	446	1
16	5510	13	19.1	298	1
17	5510	13	13.2	281	1
18	5510	14	18.9	293	1
19	5510	14	13.9	365	1
20	5510	13	14.9	247	1
21	5530	12	15.3	454	1
22	5530	14	14.8	426	1
23	5530	12	13	388	1
24	5530	15	14.9	267	1
25	5530	16	12.9	440	1
26	5530	16	12.6	358	1
27	5530	12	18.2	207	1
28	5530	15	14.5	354	1
29	5530	13	16.8	277	1
30	5530	12	13.2	341	1
Detection Percentage: 100 % (>60%)					

Table-5 Radar Type 5 Statistical Performance

Trial #	Fc (MHz)	Detection (1:yes; 0:no)
1	5510.0	1
2	5510.0	1
3	5510.0	1
4	5510.0	1
5	5510.0	1
6	5510.0	1
7	5510.0	1
8	5510.0	1
9	5510.0	1
10	5510.0	1
11	5495.2	1
12	5494.0	1
13	5497.6	1
14	5496.0	1
15	5497.6	1
16	5494.8	1
17	5492.4	1
18	5492.4	1
19	5494.8	1
20	5493.2	1
21	5527.6	1
22	5524.0	1
23	5523.6	1
24	5526.0	1
25	5525.6	1
26	5523.2	1
27	5522.8	1
28	5524.4	1
29	5524.0	1
30	5526.0	1
Detection Percentage: 100 % (>80%)		

Bin5 Statistics 1

Trial #	Pulse	Chirp (MHz)	Pulse Width (µS)	Pulse 1-2 spacing (uS)	Pulse 2-3 spacing (uS)	Pulse Start(S)	Detection (1:yes; 0:no)
0	2	13	85.1	1715		0.248598	1
1	2	13	76.5	1364		1.958078	
2	3	13	51	1293	1723	3.249594	
3	2	13	83.8	1418		5.658755	
4	2	13	93.9	1094		6.98297	
5	3	13	54.1	1332	1839	7.791507	
6	2	13	53.9	1678		9.868424	
7	1	13	88.5			11.100522	

Bin5 Statistics 2

Trial #	Pulse	Chirp (MHz)	Pulse Width (µS)	Pulse 1-2 spacing (uS)	Pulse 2-3 spacing (uS)	Pulse Start(S)	Detection (1:yes; 0:no)
0	2	13	70.3	1738		0.467464	1
1	2	13	73.3	1427		0.925894	
2	2	13	51.1	1470		1.778596	
3	3	13	51.6	1478	1948	3.069515	
4	3	13	89.7	1297	1898	4.086057	
5	3	13	95.1	1479	1241	4.855418	
6	1	13	69.9			5.172005	
7	2	13	78.1	1721		6.52221	
8	2	13	83.2	1652		7.647176	
9	2	13	82.3	1999		8.202293	
10	1	13	74.8			9.25091	
11	2	13	57.8	1470		10.186961	
12	1	13	81.5			11.006281	
13	2	13	56.5	1170		11.257782	

Bin5 Statistics 3

Trial #	Pulse	Chirp (MHz)	Pulse Width (µS)	Pulse 1-2 spacing (uS)	Pulse 2-3 spacing (uS)	Pulse Start(S)	Detection (1:yes; 0:no)
0	3	8	52.6	1499	1060	1.120158	1
1	3	8	66	1947	1414	2.644778	
2	2	8	62.5	1533		3.258635	
3	2	8	82.9	1439		5.081322	
4	1	8	87.9			5.451897	
5	3	8	75.2	1582	1638	7.172462	
6	3	8	55.8	1756	1204	8.800711	
7	1	8	76.6			10.235168	
8	1	8	96.4			11.059066	

Bin5 Statistics 4

Trial #	Pulse	Chirp (MHz)	Pulse Width (µS)	Pulse 1-2 spacing (uS)	Pulse 2-3 spacing (uS)	Pulse Start(S)	Detection (1:yes; 0:no)
0	1	15	98.5			0.544683	1
1	2	15	86.7	1452		0.872103	
2	2	15	89.1	1162		1.697659	
3	3	15	79.4	1652	1661	2.169428	
4	2	15	56.3	1605		2.845091	
5	1	15	61.9			3.99131	
6	2	15	81.4	1464		4.382516	
7	1	15	70.2			5.326855	
8	2	15	88.8	1814		6.050467	
9	2	15	53.7	1736		6.607531	
10	2	15	81.7	1042		7.365202	
11	1	15	78.6			8.395437	
12	3	15	75.4	1725	1780	9.144212	
13	2	15	62.9	1497		9.196248	
14	1	15	77			10.089721	
15	3	15	92.3	1431	1635	11.180001	
16	2	15	55.1	1130		11.869489	

Bin5 Statistics 5

Trial #	Pulse	Chirp (MHz)	Pulse Width (µS)	Pulse 1-2 spacing (µS)	Pulse 2-3 spacing (µS)	Pulse Start(S)	Detection (1:yes; 0:no)
0	3	5	71	1969	1724	0.480805	1
1	1	5	97.6			1.390031	
2	2	5	63.1	1919		1.512906	
3	3	5	92.1	1115	1524	2.469049	
4	2	5	86.4	1885		2.987265	
5	1	5	84.2			3.800884	
6	3	5	60	1682	1948	4.390945	
7	3	5	87.4	1501	1690	5.249556	
8	1	5	82.8			5.81734	
9	1	5	62.2			6.949236	
10	3	5	50.9	1481	1987	7.425818	
11	3	5	99.8	1779	1788	8.320155	
12	1	5	50.7			8.811534	
13	3	5	61.1	1487	1223	9.262701	
14	2	5	81	1153		9.909024	
15	2	5	55.5	1419		10.717281	
16	3	5	54.1	1466	1847	11.774775	

Bin5 Statistics 6

Trial #	Pulse	Chirp (MHz)	Pulse Width (µS)	Pulse 1-2 spacing (µS)	Pulse 2-3 spacing (µS)	Pulse Start(S)	Detection (1:yes; 0:no)
0	3	8	57.8	1813	1539	0.534233	1
1	2	8	94.4	1495		1.295065	
2	1	8	52.7			2.01864	
3	1	8	90.6			2.655512	
4	2	8	70.3	1948		3.790028	
5	2	8	74.2	1133		4.63512	
6	3	8	88.1	1054	1082	5.943395	
7	2	8	53.5	1579		6.463461	
8	2	8	68.6	1339		7.357091	
9	2	8	82.3	1930		8.326781	
10	2	8	61.6	1196		8.824806	
11	2	8	91.2	1801		9.855668	
12	3	8	79.6	1739	1665	10.555836	
13	1	8	75.1			11.611667	

Bin5 Statistics 7

Trial #	Pulse	Chirp (MHz)	Pulse Width (µS)	Pulse 1-2 spacing (uS)	Pulse 2-3 spacing (uS)	Pulse Start(S)	Detection (1:yes; 0:no)
0	1	10	72.8			0.683751	1
1	3	10	91.9	1599	1471	0.806953	
2	2	10	66.6	1702		1.627609	
3	3	10	54.4	1738	1775	2.952228	
4	2	10	81.6	1927		3.538291	
5	3	10	86.1	1727	1105	4.423036	
6	2	10	53	1081		5.198416	
7	2	10	60.7	1993		6.057361	
8	3	10	82.3	1960	1292	7.104266	
9	2	10	84.1	1306		7.609392	
10	3	10	96.3	1615	1384	8.360536	
11	2	10	81.7	1465		8.887528	
12	2	10	95.3	1257		9.880788	
13	2	10	92.8	1441		10.555884	
14	2	10	86.3	1232		11.343822	

Bin5 Statistics 8

Trial #	Pulse	Chirp (MHz)	Pulse Width (µS)	Pulse 1-2 spacing (uS)	Pulse 2-3 spacing (uS)	Pulse Start(S)	Detection (1:yes; 0:no)
0	3	15	68.1	1160	1162	0.646135	1
1	1	15	79.8			1.288463	
2	2	15	84.6	1136		1.962318	
3	1	15	68.6			2.673136	
4	1	15	77.3			3.492502	
5	2	15	53.8	1264		4.335717	
6	2	15	53.2	1961		5.568432	
7	2	15	87.1	1060		5.643187	
8	3	15	81.1	1917	1015	6.792305	
9	1	15	83.8			7.801495	
10	2	15	62.4	1230		8.462385	
11	3	15	78.2	1973	1641	9.325756	
12	2	15	80.3	1272		10.351404	
13	2	15	97.1	1798		10.83855	
14	3	15	64.7	1338	1156	11.925389	

Bin5 Statistics 9

Trial #	Pulse	Chirp (MHz)	Pulse Width (µS)	Pulse 1-2 spacing (uS)	Pulse 2-3 spacing (uS)	Pulse Start(S)	Detection (1:yes; 0:no)
0	3	10	50.2	1830	1749	0.61212	1
1	2	10	74.9	1728		1.232931	
2	2	10	77.2	1755		1.335972	
3	2	10	59.3	1084		2.230556	
4	3	10	98.5	1187	1747	2.744005	
5	3	10	64.5	1099	1091	3.503126	
6	2	10	69.5	1557		4.090262	
7	2	10	51.6	1907		4.910833	
8	3	10	82.9	1581	1979	5.743004	
9	2	10	95.2	1282		6.002468	
10	3	10	87.4	1082	1145	7.065421	
11	2	10	53.5	1845		7.769402	
12	2	10	80.3	1245		8.040788	
13	1	10	50.1			9.223206	
14	2	10	75.7	1669		9.961741	
15	2	10	98.9	1070		10.386684	
16	3	10	69.1	1676	1397	11.251027	
17	2	10	57.9	1899		11.580796	

Bin5 Statistics 10

Trial #	Pulse	Chirp (MHz)	Pulse Width (µS)	Pulse 1-2 spacing (uS)	Pulse 2-3 spacing (uS)	Pulse Start(S)	Detection (1:yes; 0:no)
0	2	12	51.5	1323		0.382617	1
1	1	12	95.1			1.292956	
2	2	12	88.3	1685		2.830255	
3	2	12	67.4	1121		3.036985	
4	2	12	50.5	1314		4.147578	
5	2	12	65.9	1383		5.814817	
6	2	12	61.2	1989		6.254289	
7	3	12	53.5	1602	1418	7.431481	
8	1	12	65.2			8.761593	
9	2	12	89.2	1794		9.135863	
10	1	12	74.4			10.55707	
11	3	12	57.2	1698	1545	11.412604	

Bin5 Statistics 11

Trial #	Pulse	Chirp (MHz)	Pulse Width (µS)	Pulse 1-2 spacing (uS)	Pulse 2-3 spacing (uS)	Pulse Start(S)	Detection (1:yes; 0:no)
0	2	13	73.5	1859		0.09922	1
1	1	13	97			1.249377	
2	3	13	60.9	1844	1087	1.959749	
3	2	13	79.1	1502		2.563025	
4	2	13	60.6	1250		2.835788	
5	2	13	85.4	1422		3.385054	
6	2	13	57.1	1244		4.073139	
7	1	13	94.4			5.094134	
8	2	13	67.9	1483		5.541497	
9	2	13	76.1	1050		6.583079	
10	2	13	100	1415		6.837952	
11	1	13	93.2			7.477027	
12	1	13	55.4			8.38731	
13	1	13	82.5			9.012983	
14	2	13	99.5	1070		9.810342	
15	2	13	84.9	1622		10.146207	
16	3	13	73.2	1353	1068	11.047244	
17	2	13	96	1922		11.911173	

Bin5 Statistics 12

Trial #	Pulse	Chirp (MHz)	Pulse Width (µS)	Pulse 1-2 spacing (µS)	Pulse 2-3 spacing (µS)	Pulse Start(S)	Detection (1:yes; 0:no)
0	2	10	88.6	1567		0.370201	1
1	3	10	51.2	1526	1430	0.793718	
2	2	10	65	1079		1.837671	
3	2	10	56.5	1476		2.298978	
4	2	10	72	1919		2.595367	
5	2	10	50.4	1121		3.297393	
6	2	10	64.1	1062		3.876426	
7	2	10	61.8	1415		4.539848	
8	2	10	81.1	1345		5.449675	
9	2	10	54.2	1900		5.830575	
10	1	10	75.2			6.915941	
11	2	10	68	1907		7.195928	
12	3	10	63.4	1804	1516	8.127204	
13	3	10	71.9	1693	1075	8.44261	
14	2	10	93	1244		9.105848	
15	1	10	90.7			9.972731	
16	3	10	83.3	1672	1984	10.262792	
17	3	10	53.2	1097	1319	11.22035	
18	3	10	55.5	1296	1680	11.483339	

Bin5 Statistics 13

Trial #	Pulse	Chirp (MHz)	Pulse Width (µS)	Pulse 1-2 spacing (µS)	Pulse 2-3 spacing (µS)	Pulse Start(S)	Detection (1:yes; 0:no)
0	3	19	99.9	1339	1136	0.652417	1
1	1	19	92.9			1.456986	
2	1	19	78.2			2.493099	
3	1	19	96.9			3.575149	
4	3	19	85.8	1956	1321	4.669909	
5	2	19	84.3	1072		5.495341	
6	2	19	63.2	1979		6.316464	
7	1	19	95.6			7.924603	
8	1	19	92.8			8.669384	
9	1	19	66.5			9.392689	
10	2	19	70.4	1450		10.887641	
11	3	19	84	1837	1026	11.135463	

Bin5 Statistics 14

Trial #	Pulse	Chirp (MHz)	Pulse Width (µS)	Pulse 1-2 spacing (uS)	Pulse 2-3 spacing (uS)	Pulse Start(S)	Detection (1:yes; 0:no)
0	3	15	73.9	1596	1191	0.600202	1
1	3	15	70.2	1815	1820	2.388124	
2	1	15	62.7			3.987286	
3	1	15	79.2			4.701762	
4	2	15	83.7	1957		6.206913	
5	1	15	51.4			7.544625	
6	2	15	65	1807		8.119877	
7	3	15	98.1	1534	1878	10.530557	
8	2	15	80.8	1253		11.861966	

Bin5 Statistics 15

Trial #	Pulse	Chirp (MHz)	Pulse Width (µS)	Pulse 1-2 spacing (uS)	Pulse 2-3 spacing (uS)	Pulse Start(S)	Detection (1:yes; 0:no)
0	2	19	59.3	1519		0.525524	1
1	3	19	87.1	1895	1372	0.83511	
2	3	19	87.9	1321	1638	1.379377	
3	1	19	96			1.963018	
4	3	19	75.6	1666	1685	2.50851	
5	3	19	99.9	1873	1545	3.120721	
6	3	19	62.5	1068	1093	3.97734	
7	1	19	82.8			4.24648	
8	1	19	68.9			5.071221	
9	2	19	70.9	1814		5.556107	
10	3	19	73	1023	1217	6.486349	
11	3	19	51.7	1938	1853	6.711464	
12	1	19	73.6			7.561346	
13	3	19	51.5	1802	1718	8.320587	
14	2	19	97.7	1309		8.875152	
15	2	19	78.2	1583		9.278244	
16	2	19	75.2	1152		9.846153	
17	2	19	60.9	1861		10.761796	
18	2	19	58.2	1513		11.187429	
19	2	19	75.2	1753		11.521593	

Bin5 Statistics 16

Trial #	Pulse	Chirp (MHz)	Pulse Width (µS)	Pulse 1-2 spacing (uS)	Pulse 2-3 spacing (uS)	Pulse Start(S)	Detection (1:yes; 0:no)
0	3	12	51.3	1147	1497	0.037241	1
1	2	12	73.5	1500		1.525695	
2	3	12	65.1	1785	1729	3.323834	
3	2	12	64.5	1586		4.63005	
4	3	12	97.6	1591	1616	6.172324	
5	1	12	67.6			7.835089	
6	3	12	79.5	1999	1288	8.037497	
7	3	12	81.5	1670	1882	9.88409	
8	2	12	62.3	1938		11.844297	

Bin5 Statistics 17

Trial #	Pulse	Chirp (MHz)	Pulse Width (µS)	Pulse 1-2 spacing (uS)	Pulse 2-3 spacing (uS)	Pulse Start(S)	Detection (1:yes; 0:no)
0	3	6	53.9	1694	1050	0.409703	1
1	2	6	77.5	1562		0.815896	
2	2	6	74.6	1543		1.929512	
3	2	6	79.9	1183		2.213063	
4	2	6	93.5	1393		3.109436	
5	1	6	76			3.426529	
6	2	6	65.1	1199		4.319607	
7	2	6	82.6	1890		4.844664	
8	3	6	56.5	1690	1126	5.602839	
9	2	6	55.2	1542		6.014622	
10	1	6	85			7.037451	
11	1	6	52.1			7.59926	
12	3	6	95.5	1295	1173	8.37933	
13	2	6	76.6	1127		9.227765	
14	2	6	75.9	1322		9.967637	
15	2	6	74.4	1070		10.064181	
16	1	6	74.4			11.316719	
17	2	6	92.5	1778		11.658458	

Bin5 Statistics 18

Trial #	Pulse	Chirp (MHz)	Pulse Width (µS)	Pulse 1-2 spacing (µS)	Pulse 2-3 spacing (µS)	Pulse Start(S)	Detection (1:yes; 0:no)
0	2	6	92.2	1934		0.29293	1
1	3	6	92.4	1753	1280	0.906633	
2	2	6	70.3	1704		1.303122	
3	2	6	54.1	1855		2.142813	
4	3	6	60.5	1946	1119	2.77567	
5	1	6	83			3.479083	
6	3	6	80.3	1917	1899	3.824672	
7	2	6	62.5	1535		4.644352	
8	2	6	51	1322		4.824466	
9	1	6	91.9			5.471849	
10	1	6	61.4			6.137238	
11	3	6	73.3	1623	1028	6.879612	
12	3	6	78.7	1356	1996	7.669636	
13	2	6	54.5	1074		7.959373	
14	2	6	81.1	1382		8.966204	
15	2	6	94.4	1840		9.318447	
16	2	6	80.6	1045		9.830757	
17	1	6	63.7			10.298197	
18	2	6	94	1128		11.329156	
19	3	6	98.2	1394	1681	11.8737	

Bin5 Statistics 19

Trial #	Pulse	Chirp (MHz)	Pulse Width (µS)	Pulse 1-2 spacing (uS)	Pulse 2-3 spacing (uS)	Pulse Start(S)	Detection (1:yes; 0:no)
0	3	12	92.4	1187	1417	0.494301	1
1	1	12	77.8			0.973204	
2	2	12	93	1844		1.72208	
3	2	12	70	1126		2.377454	
4	1	12	90.8			2.5558	
5	2	12	71.2	1904		3.619978	
6	3	12	72.4	1834	1357	4.030788	
7	3	12	60.5	1903	1997	4.960868	
8	2	12	65.1	1351		5.566136	
9	3	12	91.3	1209	1529	5.788148	
10	2	12	93	1484		6.890448	
11	2	12	60.6	1312		7.299625	
12	2	12	72	1343		7.842602	
13	3	12	91.8	1563	1940	8.294857	
14	3	12	50	1322	1300	9.027708	
15	3	12	76.5	1752	1204	9.926646	
16	2	12	78.6	1358		10.3897	
17	3	12	59.3	1557	1671	11.130019	
18	2	12	69.9	1744		11.91066	

Bin5 Statistics 20

Trial #	Pulse	Chirp (MHz)	Pulse Width (µS)	Pulse 1-2 spacing (uS)	Pulse 2-3 spacing (uS)	Pulse Start(S)	Detection (1:yes; 0:no)
0	3	8	81.3	1963	1523	0.537798	1
1	3	8	87.6	1316	1733	2.588405	
2	3	8	92.8	1072	1885	3.724272	
3	2	8	80.5	1391		4.993885	
4	1	8	95.7			6.069189	
5	1	8	87.9			7.99436	
6	2	8	75.2	1152		9.039513	
7	2	8	75.5	1282		10.204691	
8	3	8	66.5	1840	1316	11.260802	

Bin5 Statistics 21

Trial #	Pulse	Chirp (MHz)	Pulse Width (µS)	Pulse 1-2 spacing (uS)	Pulse 2-3 spacing (uS)	Pulse Start(S)	Detection (1:yes; 0:no)
0	3	6	95.2	1974	1620	0.606265	1
1	2	6	56	1070		2.226835	
2	1	6	84.2			2.754703	
3	1	6	97.1			4.256715	
4	1	6	85.7			5.396126	
5	2	6	66.9	1920		7.89625	
6	1	6	73.9			8.326493	
7	2	6	86.9	1123		9.890288	
8	1	6	61.2			10.772695	

Bin5 Statistics 22

Trial #	Pulse	Chirp (MHz)	Pulse Width (µS)	Pulse 1-2 spacing (uS)	Pulse 2-3 spacing (uS)	Pulse Start(S)	Detection (1:yes; 0:no)
0	1	15	77.9			0.277464	1
1	2	15	80.4	1696		1.504966	
2	2	15	91.7	1230		2.079441	
3	2	15	59.7	1407		2.580159	
4	2	15	85.7	1056		3.475086	
5	3	15	61.4	1012	1897	4.773633	
6	2	15	52.3	1937		5.543183	
7	2	15	63.9	1904		6.293	
8	1	15	97			6.664348	
9	2	15	54.4	1292		7.902553	
10	1	15	92.5			8.730964	
11	2	15	96.9	1213		9.122512	
12	1	15	96			10.207901	
13	3	15	94.8	1899	1307	10.551163	
14	2	15	78.2	1216		11.815536	

Bin5 Statistics 23

Trial #	Pulse	Chirp (MHz)	Pulse Width (µS)	Pulse 1-2 spacing (µS)	Pulse 2-3 spacing (µS)	Pulse Start(S)	Detection (1:yes; 0:no)
0	1	16	59.7			1.134059	1
1	3	16	50.2	1370	1260	2.258951	
2	1	16	72.1			3.602103	
3	2	16	61.8	1225		5.103218	
4	2	16	90.6	1516		6.501755	
5	1	16	63.4			7.864934	
6	2	16	78.7	1262		9.114365	
7	2	16	64.3	1697		9.567878	
8	2	16	60	1933		11.713412	

Bin5 Statistics 24

Trial #	Pulse	Chirp (MHz)	Pulse Width (µS)	Pulse 1-2 spacing (µS)	Pulse 2-3 spacing (µS)	Pulse Start(S)	Detection (1:yes; 0:no)
0	2	10	95.7	1251		0.783726	1
1	2	10	92.7	1782		1.433378	
2	3	10	77.1	1629	1954	3.322211	
3	2	10	96.6	1504		4.103546	
4	3	10	88	1944	1299	6.167155	
5	1	10	77.8			6.88069	
6	2	10	59.2	1544		8.288861	
7	3	10	85.3	1401	1870	10.222911	
8	1	10	89.7			11.634331	

Bin5 Statistics 25

Trial #	Pulse	Chirp (MHz)	Pulse Width (µS)	Pulse 1-2 spacing (µS)	Pulse 2-3 spacing (µS)	Pulse Start(S)	Detection (1:yes; 0:no)
0	2	11	93.2	1294		0.391017	1
1	2	11	70.4	1913		2.2835	
2	1	11	58.4			2.773417	
3	3	11	84.3	1334	1846	3.816833	
4	3	11	77.5	1905	1732	5.36609	
5	2	11	63.8	1085		6.7275	
6	2	11	99.1	1049		8.301585	
7	3	11	95.4	1375	1557	9.400264	
8	1	11	75.2			10.178513	
9	2	11	74.2	1445		11.51974	

Bin5 Statistics 26

Trial #	Pulse	Chirp (MHz)	Pulse Width (µS)	Pulse 1-2 spacing (uS)	Pulse 2-3 spacing (uS)	Pulse Start(S)	Detection (1:yes; 0:no)
0	2	17	62.8	1451		0.088959	1
1	2	17	67	1467		1.03214	
2	3	17	56.5	1319	1193	1.959417	
3	2	17	73.3	1716		2.580634	
4	3	17	78.9	1407	1559	3.986761	
5	2	17	53.7	1685		4.658039	
6	3	17	73.5	1359	1154	5.537885	
7	2	17	71.5	1460		5.732559	
8	1	17	94.1			6.825008	
9	3	17	69.4	1186	1836	7.594217	
10	2	17	61.9	1277		8.338428	
11	3	17	96.9	1765	1923	9.034707	
12	2	17	55	1869		10.110668	
13	2	17	51.3	1750		10.715551	
14	3	17	83.4	1813	1768	11.476854	

Bin5 Statistics 27

Trial #	Pulse	Chirp (MHz)	Pulse Width (µS)	Pulse 1-2 spacing (uS)	Pulse 2-3 spacing (uS)	Pulse Start(S)	Detection (1:yes; 0:no)
0	3	18	80.2	1916	1548	0.16957	1
1	1	18	74.7			1.292224	
2	3	18	63.3	1056	1991	1.419801	
3	2	18	89.1	1846		2.432232	
4	2	18	96.2	1286		2.998475	
5	2	18	84.7	1727		3.802599	
6	2	18	97.4	1489		4.331719	
7	3	18	82.3	1572	1257	5.130901	
8	1	18	92.5			5.726989	
9	2	18	88.1	1577		6.104078	
10	2	18	74.4	1293		6.885468	
11	2	18	57.9	1814		7.808278	
12	2	18	52.3	1160		8.206016	
13	2	18	92.7	1392		9.082025	
14	2	18	91	1319		9.364952	
15	3	18	91.9	1565	1711	10.283787	
16	3	18	76.7	1795	1095	11.163426	
17	2	18	74.2	1388		11.527696	

Bin5 Statistics 28

Trial #	Pulse	Chirp (MHz)	Pulse Width (µS)	Pulse 1-2 spacing (uS)	Pulse 2-3 spacing (uS)	Pulse Start(S)	Detection (1:yes; 0:no)
0	2	14	97	1233		0.283367	1
1	1	14	94			0.956376	
2	1	14	62.1			1.703135	
3	1	14	61.8			2.566699	
4	2	14	70.1	1670		3.449635	
5	2	14	96.9	1929		4.748266	
6	2	14	90.6	1145		4.998652	
7	1	14	52.5			5.644648	
8	2	14	97.3	1307		7.12615	
9	3	14	65.8	1048	1957	7.633279	
10	2	14	64.9	1908		8.597692	
11	2	14	51.2	1374		9.345519	
12	2	14	76.4	1927		9.658626	
13	2	14	80.1	1627		10.668362	
14	2	14	94.7	1099		11.635796	

Bin5 Statistics 29

Trial #	Pulse	Chirp (MHz)	Pulse Width (µS)	Pulse 1-2 spacing (uS)	Pulse 2-3 spacing (uS)	Pulse Start(S)	Detection (1:yes; 0:no)
0	1	15	59.4			0.652985	1
1	2	15	62.8	1124		0.935878	
2	2	15	58.1	1603		1.871952	
3	2	15	57.6	1081		2.280105	
4	2	15	54.3	1432		2.833142	
5	2	15	69.2	1845		3.674127	
6	1	15	57.6			4.430942	
7	1	15	99.1			5.447148	
8	2	15	75.3	1328		6.336973	
9	2	15	58.1	1804		6.57495	
10	2	15	64.7	1913		7.077095	
11	3	15	78.8	1543	1048	8.126329	
12	2	15	98.1	1949		8.912032	
13	3	15	55.2	1307	1311	9.492773	
14	2	15	78.1	1077		10.511057	
15	2	15	67.7	1357		10.865879	
16	1	15	92.2			11.431141	

Bin5 Statistics 30

Trial #	Pulse	Chirp (MHz)	Pulse Width (µS)	Pulse 1-2 spacing (uS)	Pulse 2-3 spacing (uS)	Pulse Start(S)	Detection (1:yes; 0:no)
0	2	10	62.4	1257		0.260868	1
1	2	10	95.1	1507		2.859402	
2	2	10	91.6	1440		3.591516	
3	2	10	63.2	1691		5.550664	
4	2	10	60.8	1322		6.348577	
5	1	10	57.4			7.507937	
6	2	10	87.2	1831		9.332304	
7	2	10	54	1759		10.897488	

Table-6 Radar Type 6 Statistical Performance

Trial #	Fc (MHz)	Pulse /Burst	Pulse Width (µS)	PRI (µs)	Detection (1:yes; 0:no)	Hopping Sequence
1	5490	9	1	333	1	5560.0, 5471.0, 5424.0, 5569.0, 5558.0, 5580.0, 5307.0, 5422.0, 5509.0, 5467.0, 5628.0, 5667.0, 5594.0, 5538.0, 5473.0, 5634.0, 5360.0, 5521.0, 5632.0, 5374.0, 5393.0, 5505.0, 5577.0, 5498.0, 5575.0, 5255.0, 5399.0, 5546.0, 5656.0, 5578.0, 5663.0, 5485.0, 5626.0, 5359.0, 5489.0, 5669.0, 5554.0, 5620.0, 5592.0, 5681.0, 5668.0, 5568.0, 5719.0, 5563.0, 5476.0, 5455.0, 5252.0, 5263.0, 5428.0, 5395.0, 5351.0, 5581.0, 5643.0, 5635.0, 5647.0, 5426.0, 5648.0, 5526.0, 5607.0, 5269.0, 5379.0, 5522.0, 5448.0, 5256.0, 5574.0, 5703.0, 5532.0, 5380.0, 5362.0, 5705.0, 5659.0, 5511.0, 5334.0, 5410.0, 5678.0, 5496.0, 5368.0, 5346.0, 5514.0, 5265.0, 5408.0, 5452.0, 5278.0, 5586.0, 5596.0, 5357.0, 5459.0, 5405.0, 5631.0, 5550.0, 5557.0, 5482.0, 5330.0, 5662.0, 5276.0, 5350.0, 5338.0, 5333.0, 5271.0, 5722.0 (number of hits: 10)
2	5490	9	1	333	1	5528.0, 5569.0, 5684.0, 5496.0, 5712.0, 5397.0, 5508.0, 5693.0, 5656.0, 5323.0, 5621.0, 5624.0, 5399.0, 5255.0, 5445.0, 5275.0, 5578.0, 5485.0, 5336.0, 5634.0, 5276.0, 5409.0, 5547.0, 5616.0, 5400.0, 5468.0, 5722.0, 5458.0, 5413.0, 5456.0, 5426.0, 5265.0, 5706.0, 5641.0, 5627.0, 5333.0, 5425.0, 5266.0, 5455.0, 5657.0, 5674.0, 5652.0, 5544.0, 5479.0, 5335.0, 5316.0, 5282.0, 5277.0, 5512.0, 5369.0, 5311.0, 5417.0, 5475.0, 5721.0, 5480.0, 5614.0, 5556.0, 5289.0, 5626.0, 5330.0, 5299.0, 5677.0, 5379.0, 5500.0, 5461.0, 5647.0, 5511.0, 5431.0, 5253.0, 5393.0, 5278.0, 5473.0, 5346.0, 5477.0, 5575.0, 5610.0, 5291.0, 5438.0, 5375.0, 5447.0, 5484.0, 5414.0, 5613.0, 5723.0, 5557.0, 5422.0, 5598.0, 5625.0, 5568.0, 5628.0, 5639.0, 5398.0, 5567.0, 5503.0, 5322.0, 5570.0, 5404.0, 5523.0, 5450.0, 5679.0 (number of hits: 11)
3	5490	9	1	333	1	5322.0, 5348.0, 5339.0, 5601.0, 5671.0, 5553.0, 5315.0, 5556.0, 5406.0, 5574.0, 5643.0, 5536.0, 5262.0, 5469.0, 5404.0, 5584.0, 5353.0, 5594.0, 5572.0, 5347.0, 5599.0, 5323.0, 5582.0, 5578.0, 5456.0, 5522.0, 5480.0, 5708.0, 5350.0, 5308.0, 5513.0, 5363.0, 5274.0, 5481.0, 5624.0, 5586.0, 5418.0, 5587.0, 5622.0, 5694.0, 5683.0, 5641.0, 5273.0, 5529.0, 5499.0, 5668.0, 5570.0, 5667.0, 5508.0, 5598.0, 5312.0, 5276.0, 5460.0, 5617.0, 5531.0, 5697.0, 5476.0, 5307.0, 5257.0, 5369.0, 5360.0, 5432.0, 5676.0, 5378.0, 5544.0,

						5607.0, 5399.0, 5554.0, 5284.0, 5639.0, 5710.0, 5672.0, 5523.0, 5379.0, 5470.0, 5430.0, 5405.0, 5466.0, 5461.0, 5506.0, 5367.0, 5722.0, 5576.0, 5642.0, 5585.0, 5389.0, 5291.0, 5621.0, 5486.0, 5299.0, 5290.0, 5281.0, 5630.0, 5365.0, 5609.0, 5279.0, 5327.0, 5718.0, 5329.0, 5720.0 (number of hits: 8)
4	5490	9	1	333	1	5265.0, 5680.0, 5334.0, 5317.0, 5522.0, 5472.0, 5331.0, 5274.0, 5673.0, 5388.0, 5505.0, 5690.0, 5718.0, 5277.0, 5569.0, 5627.0, 5307.0, 5357.0, 5501.0, 5415.0, 5519.0, 5669.0, 5302.0, 5437.0, 5695.0, 5682.0, 5443.0, 5441.0, 5554.0, 5487.0, 5715.0, 5348.0, 5347.0, 5670.0, 5477.0, 5280.0, 5691.0, 5337.0, 5313.0, 5474.0, 5411.0, 5636.0, 5644.0, 5279.0, 5365.0, 5408.0, 5722.0, 5702.0, 5288.0, 5465.0, 5293.0, 5628.0, 5585.0, 5577.0, 5324.0, 5638.0, 5523.0, 5589.0, 5406.0, 5446.0, 5352.0, 5386.0, 5368.0, 5721.0, 5645.0, 5436.0, 5530.0, 5646.0, 5281.0, 5486.0, 5559.0, 5540.0, 5412.0, 5435.0, 5533.0, 5471.0, 5301.0, 5345.0, 5479.0, 5373.0, 5610.0, 5689.0, 5591.0, 5346.0, 5520.0, 5594.0, 5600.0, 5534.0, 5619.0, 5430.0, 5478.0, 5399.0, 5286.0, 5282.0, 5662.0, 5326.0, 5617.0, 5604.0, 5329.0, 5455.0 (number of hits: 10)
5	5490	9	1	333	1	5599.0, 5287.0, 5590.0, 5425.0, 5645.0, 5252.0, 5301.0, 5356.0, 5305.0, 5544.0, 5631.0, 5371.0, 5704.0, 5643.0, 5367.0, 5694.0, 5527.0, 5269.0, 5344.0, 5550.0, 5560.0, 5412.0, 5660.0, 5564.0, 5432.0, 5621.0, 5566.0, 5352.0, 5370.0, 5262.0, 5651.0, 5317.0, 5358.0, 5649.0, 5454.0, 5717.0, 5582.0, 5625.0, 5456.0, 5264.0, 5598.0, 5433.0, 5624.0, 5622.0, 5363.0, 5383.0, 5679.0, 5413.0, 5585.0, 5399.0, 5635.0, 5473.0, 5669.0, 5500.0, 5419.0, 5477.0, 5494.0, 5495.0, 5626.0, 5450.0, 5644.0, 5409.0, 5443.0, 5521.0, 5700.0, 5458.0, 5272.0, 5389.0, 5312.0, 5634.0, 5299.0, 5345.0, 5708.0, 5530.0, 5435.0, 5554.0, 5253.0, 5697.0, 5462.0, 5286.0, 5535.0, 5567.0, 5523.0, 5558.0, 5464.0, 5335.0, 5308.0, 5346.0, 5291.0, 5297.0, 5400.0, 5307.0, 5640.0, 5420.0, 5534.0, 5487.0, 5315.0, 5373.0, 5461.0, 5562.0 (number of hits: 6)
6	5490	9	1	333	1	5386.0, 5556.0, 5378.0, 5628.0, 5675.0, 5712.0, 5258.0, 5701.0, 5345.0, 5363.0, 5680.0, 5305.0, 5465.0, 5601.0, 5304.0, 5634.0, 5656.0, 5687.0, 5653.0, 5641.0, 5414.0, 5541.0, 5660.0, 5694.0, 5286.0, 5417.0, 5294.0, 5347.0, 5718.0, 5487.0, 5394.0, 5545.0, 5379.0, 5573.0, 5309.0, 5397.0, 5385.0, 5547.0, 5604.0, 5448.0, 5392.0, 5711.0, 5519.0, 5466.0, 5325.0, 5616.0, 5611.0, 5441.0, 5316.0, 5575.0, 5300.0, 5276.0, 5548.0, 5564.0, 5721.0,

						5590.0, 5666.0, 5571.0, 5559.0, 5409.0, 5421.0, 5663.0, 5621.0, 5374.0, 5383.0, 5570.0, 5419.0, 5702.0, 5371.0, 5475.0, 5282.0, 5269.0, 5278.0, 5284.0, 5402.0, 5627.0, 5542.0, 5534.0, 5455.0, 5329.0, 5678.0, 5326.0, 5603.0, 5499.0, 5298.0, 5713.0, 5639.0, 5724.0, 5321.0, 5679.0, 5526.0, 5706.0, 5351.0, 5561.0, 5274.0, 5652.0, 5420.0, 5497.0, 5377.0, 5636.0 (number of hits: 4)
7	5490	9	1	333	1	5491.0, 5687.0, 5630.0, 5290.0, 5469.0, 5533.0, 5297.0, 5350.0, 5448.0, 5515.0, 5400.0, 5318.0, 5668.0, 5682.0, 5359.0, 5564.0, 5479.0, 5547.0, 5410.0, 5292.0, 5717.0, 5519.0, 5615.0, 5306.0, 5432.0, 5603.0, 5576.0, 5476.0, 5634.0, 5439.0, 5310.0, 5402.0, 5494.0, 5573.0, 5437.0, 5616.0, 5495.0, 5383.0, 5443.0, 5663.0, 5369.0, 5558.0, 5478.0, 5700.0, 5485.0, 5586.0, 5371.0, 5474.0, 5492.0, 5516.0, 5722.0, 5399.0, 5549.0, 5578.0, 5271.0, 5446.0, 5435.0, 5649.0, 5384.0, 5697.0, 5433.0, 5255.0, 5493.0, 5577.0, 5258.0, 5559.0, 5330.0, 5459.0, 5500.0, 5521.0, 5612.0, 5259.0, 5556.0, 5709.0, 5636.0, 5510.0, 5327.0, 5375.0, 5453.0, 5685.0, 5659.0, 5594.0, 5721.0, 5609.0, 5639.0, 5445.0, 5544.0, 5537.0, 5513.0, 5260.0, 5456.0, 5356.0, 5426.0, 5673.0, 5381.0, 5442.0, 5270.0, 5303.0, 5343.0, 5291.0 (number of hits: 11)
8	5490	9	1	333	1	5709.0, 5555.0, 5351.0, 5641.0, 5285.0, 5653.0, 5391.0, 5675.0, 5646.0, 5372.0, 5324.0, 5418.0, 5633.0, 5579.0, 5591.0, 5681.0, 5335.0, 5667.0, 5620.0, 5363.0, 5320.0, 5286.0, 5492.0, 5566.0, 5719.0, 5624.0, 5293.0, 5506.0, 5344.0, 5349.0, 5292.0, 5568.0, 5387.0, 5669.0, 5297.0, 5585.0, 5678.0, 5480.0, 5303.0, 5265.0, 5421.0, 5686.0, 5676.0, 5478.0, 5458.0, 5548.0, 5499.0, 5337.0, 5406.0, 5508.0, 5696.0, 5404.0, 5593.0, 5378.0, 5561.0, 5323.0, 5386.0, 5452.0, 5630.0, 5504.0, 5588.0, 5639.0, 5699.0, 5436.0, 5490.0, 5385.0, 5609.0, 5707.0, 5608.0, 5488.0, 5278.0, 5290.0, 5428.0, 5405.0, 5597.0, 5300.0, 5398.0, 5503.0, 5613.0, 5516.0, 5539.0, 5485.0, 5616.0, 5318.0, 5654.0, 5415.0, 5360.0, 5692.0, 5416.0, 5520.0, 5590.0, 5388.0, 5256.0, 5296.0, 5612.0, 5564.0, 5338.0, 5531.0, 5454.0, 5289.0 (number of hits: 11)
9	5490	9	1	333	1	5600.0, 5717.0, 5722.0, 5502.0, 5355.0, 5623.0, 5555.0, 5451.0, 5532.0, 5257.0, 5304.0, 5684.0, 5294.0, 5264.0, 5456.0, 5719.0, 5418.0, 5387.0, 5269.0, 5378.0, 5718.0, 5553.0, 5675.0, 5583.0, 5587.0, 5543.0, 5591.0, 5275.0, 5506.0, 5697.0, 5643.0, 5713.0, 5588.0, 5459.0, 5597.0, 5705.0, 5525.0, 5463.0, 5438.0, 5652.0, 5498.0, 5376.0, 5353.0, 5270.0, 5571.0,

						5511.0, 5633.0, 5354.0, 5724.0, 5403.0, 5351.0, 5537.0, 5284.0, 5380.0, 5356.0, 5708.0, 5612.0, 5462.0, 5306.0, 5694.0, 5300.0, 5503.0, 5682.0, 5409.0, 5369.0, 5672.0, 5301.0, 5676.0, 5411.0, 5586.0, 5413.0, 5585.0, 5457.0, 5659.0, 5539.0, 5381.0, 5677.0, 5328.0, 5383.0, 5629.0, 5466.0, 5253.0, 5410.0, 5579.0, 5721.0, 5565.0, 5541.0, 5429.0, 5263.0, 5614.0, 5343.0, 5256.0, 5254.0, 5536.0, 5446.0, 5627.0, 5504.0, 5371.0, 5538.0, 5648.0 (number of hits: 5)
10	5490	9	1	333	1	5581.0, 5433.0, 5452.0, 5251.0, 5481.0, 5508.0, 5704.0, 5419.0, 5723.0, 5467.0, 5592.0, 5595.0, 5417.0, 5370.0, 5282.0, 5718.0, 5322.0, 5489.0, 5531.0, 5436.0, 5575.0, 5675.0, 5385.0, 5637.0, 5351.0, 5724.0, 5399.0, 5552.0, 5327.0, 5714.0, 5576.0, 5642.0, 5361.0, 5685.0, 5389.0, 5646.0, 5546.0, 5621.0, 5296.0, 5279.0, 5605.0, 5466.0, 5406.0, 5682.0, 5506.0, 5676.0, 5589.0, 5570.0, 5568.0, 5257.0, 5681.0, 5456.0, 5411.0, 5307.0, 5660.0, 5423.0, 5701.0, 5253.0, 5630.0, 5275.0, 5306.0, 5652.0, 5415.0, 5438.0, 5458.0, 5602.0, 5655.0, 5429.0, 5414.0, 5620.0, 5464.0, 5354.0, 5387.0, 5340.0, 5680.0, 5332.0, 5709.0, 5334.0, 5391.0, 5698.0, 5292.0, 5524.0, 5280.0, 5661.0, 5673.0, 5520.0, 5453.0, 5717.0, 5397.0, 5632.0, 5697.0, 5300.0, 5337.0, 5619.0, 5578.0, 5273.0, 5379.0, 5469.0, 5431.0, 5344.0 (number of hits: 4)
11	5510	9	1	333	1	5695.0, 5660.0, 5261.0, 5380.0, 5494.0, 5431.0, 5720.0, 5374.0, 5364.0, 5385.0, 5370.0, 5488.0, 5659.0, 5698.0, 5540.0, 5442.0, 5260.0, 5331.0, 5614.0, 5483.0, 5312.0, 5608.0, 5573.0, 5276.0, 5352.0, 5722.0, 5489.0, 5400.0, 5263.0, 5497.0, 5326.0, 5427.0, 5639.0, 5551.0, 5310.0, 5350.0, 5257.0, 5302.0, 5449.0, 5336.0, 5473.0, 5655.0, 5282.0, 5358.0, 5479.0, 5644.0, 5303.0, 5357.0, 5265.0, 5468.0, 5283.0, 5293.0, 5689.0, 5316.0, 5526.0, 5318.0, 5313.0, 5367.0, 5626.0, 5641.0, 5428.0, 5381.0, 5543.0, 5667.0, 5342.0, 5438.0, 5356.0, 5668.0, 5690.0, 5619.0, 5423.0, 5269.0, 5291.0, 5274.0, 5264.0, 5685.0, 5285.0, 5658.0, 5589.0, 5666.0, 5432.0, 5429.0, 5681.0, 5323.0, 5707.0, 5439.0, 5393.0, 5687.0, 5515.0, 5654.0, 5496.0, 5330.0, 5565.0, 5251.0, 5652.0, 5709.0, 5677.0, 5661.0, 5273.0, 5452.0 (number of hits: 5)
12	5510	9	1	333	1	5345.0, 5251.0, 5421.0, 5419.0, 5351.0, 5563.0, 5667.0, 5713.0, 5469.0, 5411.0, 5633.0, 5368.0, 5711.0, 5621.0, 5610.0, 5550.0, 5431.0, 5545.0, 5611.0, 5462.0, 5281.0, 5330.0, 5321.0, 5332.0, 5629.0, 5617.0, 5423.0, 5303.0, 5644.0, 5446.0, 5522.0, 5385.0, 5595.0, 5620.0, 5518.0,

						5573.0, 5307.0, 5501.0, 5315.0, 5590.0, 5432.0, 5317.0, 5564.0, 5684.0, 5440.0, 5632.0, 5560.0, 5723.0, 5493.0, 5393.0, 5412.0, 5494.0, 5694.0, 5491.0, 5434.0, 5464.0, 5669.0, 5481.0, 5507.0, 5490.0, 5523.0, 5261.0, 5577.0, 5637.0, 5370.0, 5435.0, 5276.0, 5350.0, 5712.0, 5700.0, 5663.0, 5327.0, 5278.0, 5715.0, 5449.0, 5714.0, 5504.0, 5287.0, 5456.0, 5454.0, 5532.0, 5650.0, 5502.0, 5662.0, 5499.0, 5322.0, 5701.0, 5591.0, 5458.0, 5587.0, 5304.0, 5570.0, 5288.0, 5296.0, 5608.0, 5442.0, 5687.0, 5598.0, 5437.0, 5605.0 (number of hits: 12)
13	5510	9	1	333	1	5268.0, 5309.0, 5514.0, 5659.0, 5253.0, 5704.0, 5280.0, 5371.0, 5512.0, 5288.0, 5442.0, 5657.0, 5370.0, 5500.0, 5721.0, 5350.0, 5299.0, 5521.0, 5705.0, 5437.0, 5380.0, 5362.0, 5441.0, 5613.0, 5473.0, 5558.0, 5454.0, 5276.0, 5619.0, 5459.0, 5285.0, 5410.0, 5469.0, 5528.0, 5402.0, 5581.0, 5718.0, 5568.0, 5356.0, 5379.0, 5572.0, 5673.0, 5419.0, 5325.0, 5412.0, 5709.0, 5635.0, 5383.0, 5575.0, 5384.0, 5364.0, 5290.0, 5535.0, 5486.0, 5597.0, 5658.0, 5313.0, 5262.0, 5399.0, 5477.0, 5326.0, 5272.0, 5375.0, 5333.0, 5344.0, 5685.0, 5464.0, 5549.0, 5294.0, 5706.0, 5450.0, 5712.0, 5273.0, 5426.0, 5592.0, 5644.0, 5386.0, 5573.0, 5567.0, 5694.0, 5556.0, 5467.0, 5446.0, 5692.0, 5403.0, 5714.0, 5546.0, 5349.0, 5310.0, 5723.0, 5331.0, 5563.0, 5600.0, 5341.0, 5655.0, 5599.0, 5417.0, 5316.0, 5564.0, 5414.0 (number of hits: 5)
14	5510	9	1	333	1	5382.0, 5588.0, 5498.0, 5396.0, 5710.0, 5312.0, 5413.0, 5446.0, 5680.0, 5557.0, 5669.0, 5402.0, 5454.0, 5261.0, 5635.0, 5389.0, 5664.0, 5421.0, 5617.0, 5287.0, 5520.0, 5365.0, 5453.0, 5307.0, 5492.0, 5426.0, 5447.0, 5507.0, 5309.0, 5630.0, 5614.0, 5662.0, 5709.0, 5308.0, 5625.0, 5631.0, 5379.0, 5517.0, 5346.0, 5431.0, 5349.0, 5294.0, 5276.0, 5286.0, 5620.0, 5432.0, 5598.0, 5371.0, 5575.0, 5529.0, 5363.0, 5702.0, 5554.0, 5542.0, 5385.0, 5639.0, 5409.0, 5650.0, 5641.0, 5332.0, 5537.0, 5256.0, 5342.0, 5716.0, 5675.0, 5705.0, 5723.0, 5476.0, 5418.0, 5313.0, 5392.0, 5296.0, 5541.0, 5376.0, 5504.0, 5330.0, 5693.0, 5272.0, 5696.0, 5317.0, 5708.0, 5605.0, 5500.0, 5440.0, 5699.0, 5335.0, 5659.0, 5567.0, 5355.0, 5511.0, 5595.0, 5480.0, 5561.0, 5564.0, 5460.0, 5251.0, 5552.0, 5686.0, 5334.0, 5280.0 (number of hits: 9)
15	5510	9	1	333	1	5592.0, 5446.0, 5283.0, 5604.0, 5624.0, 5279.0, 5689.0, 5585.0, 5491.0, 5644.0, 5518.0, 5357.0, 5417.0, 5513.0, 5487.0, 5352.0, 5555.0, 5391.0, 5355.0, 5448.0, 5482.0, 5408.0, 5713.0, 5344.0, 5538.0,

						5430.0, 5350.0, 5594.0, 5258.0, 5679.0, 5716.0, 5480.0, 5287.0, 5645.0, 5377.0, 5496.0, 5553.0, 5640.0, 5646.0, 5595.0, 5642.0, 5318.0, 5692.0, 5530.0, 5311.0, 5566.0, 5322.0, 5718.0, 5260.0, 5512.0, 5412.0, 5565.0, 5611.0, 5330.0, 5251.0, 5524.0, 5632.0, 5584.0, 5542.0, 5364.0, 5339.0, 5477.0, 5552.0, 5457.0, 5610.0, 5648.0, 5268.0, 5682.0, 5609.0, 5437.0, 5436.0, 5449.0, 5452.0, 5328.0, 5544.0, 5479.0, 5310.0, 5274.0, 5305.0, 5647.0, 5380.0, 5608.0, 5686.0, 5508.0, 5373.0, 5502.0, 5302.0, 5368.0, 5576.0, 5347.0, 5534.0, 5325.0, 5425.0, 5629.0, 5620.0, 5458.0, 5548.0, 5262.0, 5572.0, 5597.0 (number of hits: 8)
16	5510	9	1	333	1	5604.0, 5592.0, 5535.0, 5525.0, 5412.0, 5537.0, 5344.0, 5337.0, 5465.0, 5350.0, 5371.0, 5255.0, 5587.0, 5428.0, 5471.0, 5698.0, 5265.0, 5466.0, 5517.0, 5533.0, 5467.0, 5563.0, 5268.0, 5677.0, 5608.0, 5708.0, 5618.0, 5442.0, 5260.0, 5282.0, 5496.0, 5700.0, 5616.0, 5305.0, 5319.0, 5580.0, 5520.0, 5609.0, 5360.0, 5701.0, 5334.0, 5459.0, 5444.0, 5501.0, 5432.0, 5368.0, 5434.0, 5631.0, 5397.0, 5294.0, 5627.0, 5594.0, 5613.0, 5512.0, 5546.0, 5687.0, 5721.0, 5314.0, 5622.0, 5574.0, 5645.0, 5493.0, 5269.0, 5299.0, 5717.0, 5606.0, 5425.0, 5290.0, 5688.0, 5393.0, 5473.0, 5720.0, 5652.0, 5306.0, 5317.0, 5553.0, 5672.0, 5718.0, 5486.0, 5590.0, 5494.0, 5669.0, 5629.0, 5456.0, 5297.0, 5256.0, 5540.0, 5544.0, 5327.0, 5342.0, 5651.0, 5458.0, 5584.0, 5343.0, 5589.0, 5668.0, 5357.0, 5719.0, 5258.0, 5686.0 (number of hits: 8)
17	5510	9	1	333	1	5493.0, 5659.0, 5365.0, 5649.0, 5658.0, 5336.0, 5514.0, 5286.0, 5676.0, 5407.0, 5694.0, 5611.0, 5496.0, 5512.0, 5333.0, 5687.0, 5656.0, 5481.0, 5565.0, 5634.0, 5253.0, 5329.0, 5276.0, 5470.0, 5411.0, 5631.0, 5554.0, 5624.0, 5403.0, 5582.0, 5572.0, 5489.0, 5586.0, 5700.0, 5325.0, 5644.0, 5259.0, 5640.0, 5675.0, 5522.0, 5574.0, 5460.0, 5613.0, 5344.0, 5604.0, 5302.0, 5323.0, 5368.0, 5668.0, 5722.0, 5326.0, 5721.0, 5317.0, 5497.0, 5529.0, 5395.0, 5714.0, 5355.0, 5316.0, 5523.0, 5510.0, 5673.0, 5401.0, 5571.0, 5704.0, 5461.0, 5418.0, 5436.0, 5292.0, 5699.0, 5346.0, 5459.0, 5715.0, 5373.0, 5623.0, 5394.0, 5600.0, 5343.0, 5651.0, 5335.0, 5348.0, 5513.0, 5452.0, 5682.0, 5561.0, 5713.0, 5580.0, 5462.0, 5599.0, 5601.0, 5307.0, 5696.0, 5606.0, 5376.0, 5409.0, 5639.0, 5442.0, 5593.0, 5252.0, 5632.0 (number of hits: 10)
18	5510	9	1	333	1	5345.0, 5297.0, 5390.0, 5266.0, 5360.0, 5342.0, 5586.0, 5652.0, 5270.0, 5439.0, 5579.0, 5560.0, 5465.0, 5612.0, 5274.0,

						5292.0, 5275.0, 5257.0, 5658.0, 5537.0, 5572.0, 5717.0, 5530.0, 5468.0, 5295.0, 5496.0, 5413.0, 5290.0, 5621.0, 5407.0, 5645.0, 5547.0, 5561.0, 5616.0, 5620.0, 5539.0, 5313.0, 5455.0, 5251.0, 5422.0, 5497.0, 5427.0, 5255.0, 5566.0, 5371.0, 5649.0, 5587.0, 5514.0, 5479.0, 5293.0, 5367.0, 5512.0, 5344.0, 5484.0, 5428.0, 5346.0, 5585.0, 5551.0, 5402.0, 5669.0, 5495.0, 5589.0, 5338.0, 5400.0, 5300.0, 5303.0, 5555.0, 5529.0, 5663.0, 5273.0, 5646.0, 5280.0, 5519.0, 5630.0, 5433.0, 5570.0, 5601.0, 5532.0, 5676.0, 5487.0, 5370.0, 5640.0, 5528.0, 5294.0, 5278.0, 5723.0, 5679.0, 5269.0, 5492.0, 5685.0, 5531.0, 5423.0, 5341.0, 5502.0, 5549.0, 5416.0, 5564.0, 5374.0, 5690.0, 5392.0 (number of hits: 10)
19	5510	9	1	333	1	5663.0, 5299.0, 5499.0, 5532.0, 5671.0, 5515.0, 5528.0, 5340.0, 5313.0, 5323.0, 5466.0, 5640.0, 5439.0, 5487.0, 5546.0, 5417.0, 5364.0, 5694.0, 5505.0, 5501.0, 5375.0, 5670.0, 5432.0, 5608.0, 5395.0, 5315.0, 5652.0, 5308.0, 5690.0, 5568.0, 5516.0, 5284.0, 5295.0, 5534.0, 5559.0, 5524.0, 5307.0, 5420.0, 5429.0, 5716.0, 5324.0, 5321.0, 5389.0, 5518.0, 5290.0, 5537.0, 5452.0, 5607.0, 5437.0, 5580.0, 5650.0, 5626.0, 5330.0, 5564.0, 5584.0, 5480.0, 5388.0, 5577.0, 5677.0, 5639.0, 5672.0, 5341.0, 5542.0, 5698.0, 5513.0, 5675.0, 5696.0, 5484.0, 5371.0, 5469.0, 5293.0, 5550.0, 5596.0, 5641.0, 5350.0, 5378.0, 5517.0, 5713.0, 5627.0, 5419.0, 5535.0, 5361.0, 5476.0, 5458.0, 5254.0, 5569.0, 5645.0, 5346.0, 5637.0, 5441.0, 5710.0, 5414.0, 5451.0, 5454.0, 5442.0, 5306.0, 5492.0, 5328.0, 5300.0, 5369.0 (number of hits: 11)
20	5510	9	1	333	1	5589.0, 5674.0, 5673.0, 5592.0, 5642.0, 5551.0, 5501.0, 5314.0, 5322.0, 5448.0, 5503.0, 5252.0, 5296.0, 5677.0, 5626.0, 5559.0, 5374.0, 5703.0, 5655.0, 5675.0, 5400.0, 5577.0, 5602.0, 5664.0, 5482.0, 5533.0, 5339.0, 5529.0, 5545.0, 5335.0, 5511.0, 5275.0, 5535.0, 5272.0, 5454.0, 5299.0, 5676.0, 5389.0, 5403.0, 5607.0, 5421.0, 5420.0, 5305.0, 5681.0, 5556.0, 5705.0, 5653.0, 5719.0, 5525.0, 5408.0, 5338.0, 5355.0, 5587.0, 5452.0, 5304.0, 5668.0, 5470.0, 5518.0, 5582.0, 5323.0, 5608.0, 5641.0, 5507.0, 5315.0, 5519.0, 5288.0, 5580.0, 5395.0, 5622.0, 5368.0, 5384.0, 5332.0, 5316.0, 5471.0, 5297.0, 5615.0, 5575.0, 5367.0, 5620.0, 5654.0, 5722.0, 5468.0, 5685.0, 5411.0, 5263.0, 5438.0, 5372.0, 5268.0, 5309.0, 5508.0, 5635.0, 5464.0, 5344.0, 5578.0, 5450.0, 5659.0, 5361.0, 5429.0, 5691.0, 5397.0 (number of hits: 9)
21	5530	9	1	333	1	5322.0, 5605.0, 5344.0, 5610.0, 5539.0,

						5285.0, 5526.0, 5506.0, 5487.0, 5481.0, 5253.0, 5551.0, 5453.0, 5706.0, 5445.0, 5491.0, 5387.0, 5502.0, 5715.0, 5688.0, 5443.0, 5617.0, 5557.0, 5517.0, 5664.0, 5587.0, 5292.0, 5299.0, 5683.0, 5582.0, 5378.0, 5409.0, 5362.0, 5638.0, 5541.0, 5391.0, 5254.0, 5709.0, 5359.0, 5370.0, 5385.0, 5316.0, 5410.0, 5442.0, 5508.0, 5264.0, 5567.0, 5696.0, 5343.0, 5473.0, 5441.0, 5678.0, 5399.0, 5615.0, 5708.0, 5430.0, 5288.0, 5648.0, 5489.0, 5303.0, 5257.0, 5425.0, 5386.0, 5570.0, 5284.0, 5524.0, 5364.0, 5562.0, 5469.0, 5629.0, 5680.0, 5634.0, 5482.0, 5320.0, 5290.0, 5400.0, 5633.0, 5427.0, 5330.0, 5701.0, 5722.0, 5694.0, 5528.0, 5265.0, 5639.0, 5312.0, 5620.0, 5584.0, 5597.0, 5650.0, 5533.0, 5252.0, 5509.0, 5268.0, 5478.0, 5576.0, 5510.0, 5668.0, 5475.0, 5553.0 (number of hits: 8)
22	5530	9	1	333	1	5397.0, 5724.0, 5711.0, 5553.0, 5352.0, 5413.0, 5470.0, 5642.0, 5388.0, 5293.0, 5686.0, 5583.0, 5358.0, 5395.0, 5291.0, 5569.0, 5573.0, 5282.0, 5715.0, 5456.0, 5383.0, 5343.0, 5385.0, 5497.0, 5625.0, 5272.0, 5685.0, 5695.0, 5554.0, 5475.0, 5298.0, 5588.0, 5403.0, 5489.0, 5452.0, 5714.0, 5405.0, 5336.0, 5612.0, 5454.0, 5517.0, 5469.0, 5299.0, 5487.0, 5415.0, 5521.0, 5289.0, 5283.0, 5300.0, 5507.0, 5320.0, 5340.0, 5586.0, 5325.0, 5435.0, 5458.0, 5372.0, 5661.0, 5692.0, 5419.0, 5640.0, 5350.0, 5319.0, 5533.0, 5580.0, 5496.0, 5348.0, 5653.0, 5492.0, 5645.0, 5592.0, 5562.0, 5376.0, 5400.0, 5557.0, 5417.0, 5526.0, 5518.0, 5563.0, 5365.0, 5448.0, 5654.0, 5268.0, 5314.0, 5541.0, 5311.0, 5566.0, 5449.0, 5380.0, 5440.0, 5369.0, 5672.0, 5547.0, 5409.0, 5548.0, 5406.0, 5366.0, 5255.0, 5290.0, 5641.0 (number of hits: 8)
23	5530	9	1	333	1	5264.0, 5558.0, 5349.0, 5675.0, 5543.0, 5674.0, 5459.0, 5496.0, 5594.0, 5569.0, 5709.0, 5540.0, 5575.0, 5659.0, 5324.0, 5685.0, 5434.0, 5681.0, 5268.0, 5454.0, 5254.0, 5314.0, 5346.0, 5706.0, 5363.0, 5310.0, 5383.0, 5417.0, 5339.0, 5715.0, 5318.0, 5426.0, 5515.0, 5573.0, 5589.0, 5522.0, 5644.0, 5407.0, 5299.0, 5483.0, 5549.0, 5315.0, 5366.0, 5368.0, 5511.0, 5591.0, 5480.0, 5571.0, 5595.0, 5645.0, 5538.0, 5472.0, 5632.0, 5602.0, 5448.0, 5389.0, 5704.0, 5465.0, 5611.0, 5325.0, 5696.0, 5250.0, 5719.0, 5497.0, 5568.0, 5445.0, 5600.0, 5415.0, 5676.0, 5402.0, 5586.0, 5331.0, 5641.0, 5452.0, 5395.0, 5556.0, 5276.0, 5654.0, 5718.0, 5376.0, 5614.0, 5531.0, 5403.0, 5527.0, 5436.0, 5259.0, 5548.0, 5343.0, 5577.0, 5710.0, 5583.0, 5673.0, 5525.0, 5420.0, 5658.0, 5517.0, 5370.0, 5479.0, 5535.0, 5377.0

						(number of hits: 13)
24	5530	9	1	333	1	5254.0, 5554.0, 5675.0, 5528.0, 5503.0, 5344.0, 5491.0, 5262.0, 5570.0, 5289.0, 5559.0, 5629.0, 5631.0, 5676.0, 5613.0, 5596.0, 5604.0, 5373.0, 5624.0, 5412.0, 5663.0, 5392.0, 5261.0, 5411.0, 5375.0, 5653.0, 5427.0, 5560.0, 5457.0, 5628.0, 5669.0, 5415.0, 5643.0, 5325.0, 5636.0, 5274.0, 5380.0, 5374.0, 5305.0, 5477.0, 5394.0, 5637.0, 5385.0, 5665.0, 5703.0, 5611.0, 5453.0, 5625.0, 5502.0, 5303.0, 5467.0, 5529.0, 5349.0, 5566.0, 5458.0, 5546.0, 5390.0, 5306.0, 5309.0, 5717.0, 5311.0, 5459.0, 5371.0, 5519.0, 5576.0, 5672.0, 5470.0, 5402.0, 5701.0, 5707.0, 5463.0, 5250.0, 5724.0, 5511.0, 5555.0, 5581.0, 5562.0, 5429.0, 5294.0, 5354.0, 5449.0, 5281.0, 5396.0, 5594.0, 5691.0, 5329.0, 5352.0, 5683.0, 5356.0, 5572.0, 5367.0, 5287.0, 5323.0, 5658.0, 5595.0, 5348.0, 5319.0, 5265.0, 5450.0, 5583.0
						(number of hits: 5)
25	5530	9	1	333	1	5546.0, 5483.0, 5278.0, 5682.0, 5291.0, 5536.0, 5436.0, 5616.0, 5477.0, 5281.0, 5265.0, 5704.0, 5413.0, 5417.0, 5398.0, 5270.0, 5415.0, 5671.0, 5631.0, 5353.0, 5277.0, 5709.0, 5561.0, 5263.0, 5366.0, 5255.0, 5419.0, 5695.0, 5479.0, 5645.0, 5545.0, 5575.0, 5425.0, 5414.0, 5504.0, 5343.0, 5551.0, 5422.0, 5458.0, 5471.0, 5706.0, 5694.0, 5323.0, 5279.0, 5511.0, 5361.0, 5513.0, 5581.0, 5299.0, 5696.0, 5601.0, 5457.0, 5346.0, 5659.0, 5693.0, 5261.0, 5416.0, 5499.0, 5411.0, 5269.0, 5627.0, 5377.0, 5600.0, 5448.0, 5643.0, 5395.0, 5454.0, 5418.0, 5579.0, 5715.0, 5392.0, 5517.0, 5383.0, 5354.0, 5258.0, 5374.0, 5713.0, 5302.0, 5257.0, 5322.0, 5585.0, 5274.0, 5700.0, 5711.0, 5646.0, 5357.0, 5460.0, 5390.0, 5539.0, 5347.0, 5560.0, 5451.0, 5482.0, 5613.0, 5253.0, 5505.0, 5606.0, 5484.0, 5542.0, 5491.0
						(number of hits: 8)
26	5530	9	1	333	1	5438.0, 5506.0, 5450.0, 5305.0, 5611.0, 5691.0, 5617.0, 5493.0, 5288.0, 5461.0, 5607.0, 5518.0, 5445.0, 5525.0, 5563.0, 5580.0, 5504.0, 5588.0, 5280.0, 5503.0, 5345.0, 5717.0, 5483.0, 5715.0, 5623.0, 5433.0, 5320.0, 5601.0, 5325.0, 5447.0, 5509.0, 5349.0, 5329.0, 5439.0, 5362.0, 5307.0, 5460.0, 5527.0, 5721.0, 5393.0, 5532.0, 5356.0, 5402.0, 5562.0, 5614.0, 5377.0, 5557.0, 5261.0, 5300.0, 5458.0, 5281.0, 5681.0, 5407.0, 5273.0, 5446.0, 5571.0, 5361.0, 5516.0, 5420.0, 5313.0, 5481.0, 5340.0, 5643.0, 5627.0, 5594.0, 5680.0, 5619.0, 5268.0, 5553.0, 5667.0, 5399.0, 5499.0, 5328.0, 5413.0, 5429.0, 5486.0, 5530.0, 5641.0, 5538.0, 5714.0, 5354.0, 5703.0, 5579.0, 5263.0, 5360.0, 5406.0, 5379.0, 5570.0, 5314.0, 5359.0

						5696.0, 5431.0, 5487.0, 5497.0, 5270.0, 5552.0, 5310.0, 5297.0, 5301.0, 5618.0 (number of hits: 7)
27	5530	9	1	333	1	5679.0, 5642.0, 5323.0, 5278.0, 5547.0, 5652.0, 5578.0, 5355.0, 5400.0, 5315.0, 5558.0, 5666.0, 5635.0, 5265.0, 5448.0, 5546.0, 5662.0, 5627.0, 5522.0, 5508.0, 5488.0, 5596.0, 5430.0, 5421.0, 5300.0, 5420.0, 5408.0, 5617.0, 5332.0, 5703.0, 5491.0, 5723.0, 5258.0, 5464.0, 5683.0, 5500.0, 5601.0, 5283.0, 5647.0, 5394.0, 5389.0, 5673.0, 5409.0, 5274.0, 5676.0, 5395.0, 5352.0, 5375.0, 5632.0, 5354.0, 5653.0, 5681.0, 5669.0, 5459.0, 5466.0, 5373.0, 5281.0, 5366.0, 5607.0, 5616.0, 5649.0, 5715.0, 5266.0, 5277.0, 5495.0, 5657.0, 5337.0, 5588.0, 5707.0, 5520.0, 5521.0, 5592.0, 5418.0, 5383.0, 5399.0, 5593.0, 5557.0, 5699.0, 5648.0, 5307.0, 5374.0, 5686.0, 5269.0, 5445.0, 5437.0, 5516.0, 5485.0, 5630.0, 5442.0, 5447.0, 5622.0, 5600.0, 5435.0, 5584.0, 5385.0, 5296.0, 5483.0, 5551.0, 5324.0, 5393.0 (number of hits: 6)
28	5530	9	1	333	1	5609.0, 5700.0, 5309.0, 5307.0, 5265.0, 5663.0, 5516.0, 5356.0, 5676.0, 5466.0, 5299.0, 5345.0, 5689.0, 5438.0, 5387.0, 5542.0, 5518.0, 5384.0, 5259.0, 5561.0, 5524.0, 5327.0, 5342.0, 5311.0, 5631.0, 5595.0, 5579.0, 5378.0, 5654.0, 5268.0, 5348.0, 5439.0, 5304.0, 5651.0, 5434.0, 5252.0, 5658.0, 5278.0, 5328.0, 5433.0, 5603.0, 5514.0, 5367.0, 5709.0, 5537.0, 5485.0, 5552.0, 5396.0, 5707.0, 5575.0, 5489.0, 5358.0, 5341.0, 5505.0, 5417.0, 5377.0, 5455.0, 5566.0, 5402.0, 5321.0, 5553.0, 5722.0, 5357.0, 5506.0, 5467.0, 5470.0, 5512.0, 5554.0, 5310.0, 5683.0, 5444.0, 5281.0, 5388.0, 5645.0, 5254.0, 5451.0, 5267.0, 5461.0, 5625.0, 5350.0, 5374.0, 5283.0, 5557.0, 5699.0, 5306.0, 5413.0, 5453.0, 5432.0, 5319.0, 5608.0, 5372.0, 5410.0, 5488.0, 5723.0, 5486.0, 5570.0, 5584.0, 5498.0, 5300.0, 5279.0 (number of hits: 7)
29	5530	9	1	333	1	5282.0, 5312.0, 5695.0, 5697.0, 5353.0, 5564.0, 5601.0, 5261.0, 5698.0, 5655.0, 5520.0, 5367.0, 5699.0, 5436.0, 5366.0, 5321.0, 5517.0, 5330.0, 5610.0, 5324.0, 5361.0, 5370.0, 5267.0, 5382.0, 5264.0, 5711.0, 5415.0, 5714.0, 5479.0, 5271.0, 5537.0, 5624.0, 5313.0, 5595.0, 5723.0, 5620.0, 5493.0, 5450.0, 5294.0, 5378.0, 5649.0, 5368.0, 5291.0, 5473.0, 5583.0, 5635.0, 5696.0, 5670.0, 5708.0, 5616.0, 5468.0, 5411.0, 5394.0, 5519.0, 5352.0, 5396.0, 5379.0, 5629.0, 5456.0, 5719.0, 5637.0, 5336.0, 5653.0, 5648.0, 5310.0, 5320.0, 5654.0, 5298.0, 5586.0, 5390.0, 5347.0, 5638.0, 5514.0, 5650.0, 5576.0, 5328.0, 5499.0, 5428.0, 5630.0, 5502.0,

						5355.0, 5565.0, 5486.0, 5691.0, 5506.0, 5430.0, 5582.0, 5494.0, 5718.0, 5548.0, 5357.0, 5257.0, 5530.0, 5547.0, 5434.0, 5424.0, 5258.0, 5288.0, 5488.0, 5464.0 (number of hits: 8)
30	5530	9	1	333	1	5368.0, 5333.0, 5455.0, 5654.0, 5645.0, 5283.0, 5519.0, 5636.0, 5601.0, 5461.0, 5334.0, 5359.0, 5542.0, 5644.0, 5397.0, 5269.0, 5658.0, 5342.0, 5647.0, 5431.0, 5380.0, 5311.0, 5708.0, 5668.0, 5320.0, 5660.0, 5389.0, 5292.0, 5349.0, 5559.0, 5251.0, 5319.0, 5671.0, 5341.0, 5353.0, 5716.0, 5489.0, 5436.0, 5598.0, 5463.0, 5258.0, 5454.0, 5313.0, 5486.0, 5305.0, 5326.0, 5621.0, 5434.0, 5277.0, 5673.0, 5441.0, 5676.0, 5385.0, 5487.0, 5665.0, 5390.0, 5332.0, 5480.0, 5370.0, 5304.0, 5631.0, 5483.0, 5255.0, 5582.0, 5666.0, 5331.0, 5488.0, 5520.0, 5407.0, 5547.0, 5589.0, 5694.0, 5640.0, 5444.0, 5599.0, 5669.0, 5495.0, 5481.0, 5364.0, 5299.0, 5570.0, 5423.0, 5553.0, 5275.0, 5549.0, 5639.0, 5531.0, 5679.0, 5272.0, 5472.0, 5478.0, 5554.0, 5622.0, 5273.0, 5459.0, 5606.0, 5535.0, 5623.0, 5316.0, 5691.0 (number of hits: 7)

A.3 80 MHz Bandwidth @ 5530 MHz

Table-1A/1B Radar Type 1A/1B Statistical Performance

Trial #	Fc (MHz)	Pulse/Burst	Pulse Width (µS)	PRI (µs)	Detection (1:yes; 0:no)
1	5490	83	1	638	1
2	5490	81	1	658	1
3	5490	58	1	918	1
4	5490	74	1	718	1
5	5490	78	1	678	1
6	5530	70	1	758	1
7	5530	95	1	558	1
8	5530	76	1	698	1
9	5530	92	1	578	1
10	5530	61	1	878	1
11	5570	67	1	798	1
12	5570	86	1	618	1
13	5570	89	1	598	1
14	5570	102	1	518	1
15	5570	99	1	538	1
16	5490	33	1	1614	1
17	5490	29	1	1846	1
18	5490	26	1	2042	1
19	5490	23	1	2362	1
20	5490	24	1	2223	1
21	5530	20	1	2654	1
22	5530	18	1	2986	1
23	5530	22	1	2458	1
24	5530	20	1	2667	1
25	5530	29	1	1876	1
26	5570	22	1	2427	1
27	5570	19	1	2878	1
28	5570	22	1	2497	1
29	5570	24	1	2251	1
30	5570	57	1	939	1
Detection Percentage: 100 % (>60%)					

Table-2 Radar Type 2 Statistical Performance

Trial #	Fc (MHz)	Pulse/Burst	Pulse Width (μ S)	PRI (μ s)	Detection (1:yes; 0:no)
1	5490	27	3.5	206	1
2	5490	26	4.3	197	1
3	5490	23	3.8	155	1
4	5490	25	1.1	161	1
5	5490	24	4.7	212	1
6	5490	28	1.6	170	1
7	5490	26	3.4	230	1
8	5490	27	4.4	160	1
9	5490	24	1.9	210	1
10	5490	24	2.9	202	1
11	5530	26	3.2	225	1
12	5530	23	1	211	1
13	5530	29	2	197	1
14	5530	23	3	193	1
15	5530	23	1.7	155	1
16	5530	27	4.8	219	1
17	5530	23	1.1	181	1
18	5530	29	4.7	187	1
19	5530	27	2.2	208	1
20	5530	28	3.1	220	1
21	5570	27	4.6	153	0
22	5570	23	2.1	188	0
23	5570	26	4.3	178	1
24	5570	29	2.6	151	1
25	5570	28	2.7	164	1
26	5570	28	1.3	156	1
27	5570	24	3.1	155	1
28	5570	25	3.2	186	1
29	5570	24	3.9	219	1
30	5570	29	1.9	176	1
Detection Percentage: 93.33 % (>60%)					

Table-3 Radar Type 3 Statistical Performance

Trial #	Fc (MHz)	Pulse/Burst	Pulse Width (μS)	PRI (μs)	Detection (1:yes; 0:no)
1	5490	16	6.8	284	1
2	5490	16	6.6	213	1
3	5490	18	8.1	243	1
4	5490	17	6.6	264	1
5	5490	17	8.8	237	1
6	5490	18	9.3	409	1
7	5490	17	10	453	1
8	5490	16	9.6	304	1
9	5490	18	9.8	339	1
10	5490	16	6.6	432	1
11	5530	18	7.6	207	1
12	5530	17	6.9	241	1
13	5530	18	7.6	246	1
14	5530	16	7	242	1
15	5530	18	7.6	435	1
16	5530	17	8.9	213	1
17	5530	17	8.3	312	1
18	5530	18	9.8	212	1
19	5530	18	6.1	330	1
20	5530	17	6.1	483	1
21	5570	17	6.9	258	1
22	5570	16	6.1	472	1
23	5570	18	7.7	214	1
24	5570	18	9.9	259	0
25	5570	18	8.6	222	1
26	5570	18	9.6	411	1
27	5570	16	8.2	360	0
28	5570	17	9.7	398	1
29	5570	17	6.5	485	1
30	5570	16	7.9	430	1
Detection Percentage: 93.33 % (>60%)					

Table-4 Radar Type 4 Statistical Performance

Trial #	Fc (MHz)	Pulse/Burst	Pulse Width (μS)	PRI (μs)	Detection (1:yes; 0:no)
1	5490	15	12.9	352	1
2	5490	14	11.4	269	1
3	5490	16	20	330	1
4	5490	13	13.2	295	1
5	5490	15	17.6	462	1
6	5490	12	11.8	267	1
7	5490	15	11.7	225	1
8	5490	12	18.7	224	1
9	5490	14	12.6	276	1
10	5490	13	13.4	287	1
11	5530	12	15.1	349	1
12	5530	13	18.2	243	1
13	5530	14	19.6	407	1
14	5530	15	17.6	500	1
15	5530	13	12.2	328	1
16	5530	15	11.9	266	1
17	5530	16	16.8	424	1
18	5530	14	12	337	1
19	5530	15	13.2	257	1
20	5530	12	19	366	1
21	5570	13	14.4	330	1
22	5570	15	12.3	480	1
23	5570	16	17.8	359	1
24	5570	15	12.4	422	1
25	5570	13	14.6	470	1
26	5570	12	17	280	1
27	5570	14	11.4	462	0
28	5570	13	14.2	455	1
29	5570	14	12.6	303	1
30	5570	16	16.8	434	1
Detection Percentage: 96.67 % (>60%)					

Table-5 Radar Type 5 Statistical Performance

Trial #	Fc (MHz)	Detection (1:yes; 0:no)
1	5530.0	1
2	5530.0	1
3	5530.0	1
4	5530.0	1
5	5530.0	1
6	5530.0	1
7	5530.0	1
8	5530.0	1
9	5530.0	1
10	5530.0	1
11	5494.0	1
12	5497.6	1
13	5493.2	1
14	5494.4	1
15	5497.6	1
16	5492.8	1
17	5492.0	1
18	5492.8	1
19	5494.4	1
20	5492.8	1
21	5563.2	1
22	5564.4	1
23	5562.4	1
24	5565.6	1
25	5566.8	1
26	5562.0	1
27	5568.0	1
28	5566.4	1
29	5567.6	1
30	5564.0	1
Detection Percentage: 100 % (>80%)		

Bin5 Statistics 1

Trial #	Pulse	Chirp (MHz)	Pulse Width (µS)	Pulse 1-2 spacing (uS)	Pulse 2-3 spacing (uS)	Pulse Start(S)	Detection (1:yes; 0:no)
0	2	14	62.9	1780		1.237988	1
1	3	14	89.8	1861	1797	2.16936	
2	1	14	80.9			3.626822	
3	2	14	79.1	1657		4.290515	
4	2	14	51.4	1232		5.67044	
5	2	14	96.5	1495		6.926632	
6	2	14	69.3	1521		8.476314	
7	3	14	64.3	1963	1243	10.066572	
8	2	14	77	1239		10.757316	

Bin5 Statistics 2

Trial #	Pulse	Chirp (MHz)	Pulse Width (µS)	Pulse 1-2 spacing (uS)	Pulse 2-3 spacing (uS)	Pulse Start(S)	Detection (1:yes; 0:no)
0	2	6	67.7	1976		0.531475	1
1	2	6	82.9	1187		0.94378	
2	2	6	70	1455		1.753634	
3	2	6	57.6	1636		2.688618	
4	3	6	57.3	1849	1062	3.398629	
5	1	6	85.6			4.15218	
6	2	6	90.9	1933		4.87535	
7	1	6	61			6.072733	
8	2	6	77.6	1814		6.577473	
9	3	6	51.6	1638	1436	7.49939	
10	2	6	51.5	1161		8.101563	
11	3	6	62.8	1690	1174	9.359549	
12	1	6	84.4			10.067754	
13	1	6	50.7			10.612657	
14	3	6	98.8	1055	1731	11.823522	

Bin5 Statistics 3

Trial #	Pulse	Chirp (MHz)	Pulse Width (µS)	Pulse 1-2 spacing (uS)	Pulse 2-3 spacing (uS)	Pulse Start(S)	Detection (1:yes; 0:no)
0	1	12	92.3			0.968488	1
1	1	12	91.5			1.178278	
2	1	12	68.4			3.013542	
3	2	12	90.1	1484		3.890174	
4	1	12	75.2			4.985001	
5	3	12	71.6	1195	1716	5.458809	
6	2	12	73.2	1466		7.15287	
7	2	12	51.1	1718		8.651453	
8	2	12	68.7	1094		8.979627	
9	1	12	83.7			10.278937	
10	3	12	65.2	1615	1407	11.810421	

Bin5 Statistics 4

Trial #	Pulse	Chirp (MHz)	Pulse Width (µS)	Pulse 1-2 spacing (uS)	Pulse 2-3 spacing (uS)	Pulse Start(S)	Detection (1:yes; 0:no)
0	3	12	59.6	1184	1260	0.422566	1
1	3	12	60.8	1932	1983	0.932867	
2	1	12	56.3			1.942599	
3	2	12	88.1	1199		2.446682	
4	2	12	73.3	1859		3.427485	
5	2	12	60.4	1964		4.612184	
6	2	12	57.8	1707		4.83206	
7	3	12	53.1	1420	1436	6.272115	
8	1	12	60.1			6.575908	
9	3	12	83.1	1456	1514	7.596547	
10	3	12	78.2	1683	1861	8.321729	
11	1	12	80.9			8.884714	
12	2	12	63.2	1020		9.928628	
13	1	12	70.1			10.970651	
14	2	12	78	1235		11.664211	

Bin5 Statistics 5

Trial #	Pulse	Chirp (MHz)	Pulse Width (µS)	Pulse 1-2 spacing (uS)	Pulse 2-3 spacing (uS)	Pulse Start(S)	Detection (1:yes; 0:no)
0	1	8	53.7			0.255571	1
1	2	8	56.7	1212		1.653533	
2	2	8	99.3	1036		2.25688	
3	2	8	63.6	1183		3.712511	
4	1	8	56.6			4.451316	
5	2	8	75.4	1586		6.231013	
6	2	8	79.3	1363		6.64893	
7	1	8	72.3			8.396089	
8	2	8	67.6	1377		9.190918	
9	2	8	96.3	1655		10.746589	
10	2	8	87.4	1062		11.733288	

Bin5 Statistics 6

Trial #	Pulse	Chirp (MHz)	Pulse Width (µS)	Pulse 1-2 spacing (uS)	Pulse 2-3 spacing (uS)	Pulse Start(S)	Detection (1:yes; 0:no)
0	3	6	59.5	1121	1487	0.65645	1
1	3	6	92.8	1811	1181	1.868644	
2	1	6	89.3			2.546034	
3	2	6	51.8	1685		4.673214	
4	3	6	68.5	1989	1812	5.167224	
5	2	6	63.5	1396		6.672416	
6	1	6	69.2			7.441722	
7	1	6	79.1			9.007911	
8	1	6	62.2			10.647919	
9	3	6	78	1717	1551	10.832161	

Bin5 Statistics 7

Trial #	Pulse	Chirp (MHz)	Pulse Width (µS)	Pulse 1-2 spacing (uS)	Pulse 2-3 spacing (uS)	Pulse Start(S)	Detection (1:yes; 0:no)
0	1	8	92.8			0.226119	1
1	1	8	99			0.897512	
2	3	8	89.3	1158	1349	1.428366	
3	2	8	90.5	1817		2.407505	
4	2	8	93.1	1824		2.981179	
5	2	8	72.4	1847		3.600002	
6	2	8	88	1926		4.288306	
7	3	8	57.3	1847	1600	4.927478	
8	3	8	91.7	1463	1251	5.412758	
9	3	8	97.3	1642	1965	6.216178	
10	2	8	66.4	1067		6.381438	
11	2	8	56.9	1366		7.174384	
12	3	8	78.4	1673	1976	7.613688	
13	2	8	56.4	1962		8.753221	
14	3	8	68	1118	1876	9.36712	
15	2	8	50.9	1087		9.671513	
16	2	8	55	1561		10.527794	
17	2	8	57.9	1835		11.05924	
18	1	8	80.4			11.932431	

Bin5 Statistics 8

Trial #	Pulse	Chirp (MHz)	Pulse Width (µS)	Pulse 1-2 spacing (uS)	Pulse 2-3 spacing (uS)	Pulse Start(S)	Detection (1:yes; 0:no)
0	2	13	77.5	1101		0.312779	1
1	2	13	70.6	1807		1.755763	
2	2	13	88.6	1694		2.494159	
3	2	13	64.8	1254		4.576615	
4	2	13	71.4	1553		5.744015	
5	3	13	73.1	1575	1482	6.39843	
6	3	13	87.6	1704	1721	8.355571	
7	2	13	98	1913		9.515978	
8	1	13	73.4			10.701475	
9	3	13	91.2	1746	1113	11.392163	

Bin5 Statistics 9

Trial #	Pulse	Chirp (MHz)	Pulse Width (µS)	Pulse 1-2 spacing (uS)	Pulse 2-3 spacing (uS)	Pulse Start(S)	Detection (1:yes; 0:no)
0	2	5	73	1363		0.141708	1
1	1	5	85.4			0.879245	
2	2	5	67.4	1897		1.991637	
3	1	5	79			2.583811	
4	1	5	69.1			3.346906	
5	1	5	56.8			3.901746	
6	2	5	87	1035		4.306512	
7	2	5	75.8	1507		5.241147	
8	3	5	67.9	1702	1451	5.8247	
9	3	5	93.8	1445	1983	6.44937	
10	1	5	55.5			7.396494	
11	2	5	87	1126		7.949717	
12	1	5	89.6			8.588195	
13	1	5	68.1			9.765774	
14	2	5	76.9	1423		10.019468	
15	1	5	67			10.795203	
16	1	5	98.1			11.841868	

Bin5 Statistics 10

Trial #	Pulse	Chirp (MHz)	Pulse Width (µS)	Pulse 1-2 spacing (uS)	Pulse 2-3 spacing (uS)	Pulse Start(S)	Detection (1:yes; 0:no)
0	3	12	63.3	1920	1689	0.515184	1
1	1	12	75.1			1.491188	
2	3	12	90.1	1215	1557	2.454504	
3	2	12	89.5	1798		3.004807	
4	2	12	70.1	1917		4.420006	
5	2	12	89.2	1866		5.502661	
6	2	12	69.5	1649		6.042936	
7	1	12	92.5			6.940743	
8	1	12	92.4			7.616405	
9	2	12	58.7	1282		8.975499	
10	2	12	84.2	1776		9.696779	
11	1	12	65.2			10.856438	
12	1	12	87.3			11.319277	

Bin5 Statistics 11

Trial #	Pulse	Chirp (MHz)	Pulse Width (µS)	Pulse 1-2 spacing (uS)	Pulse 2-3 spacing (uS)	Pulse Start(S)	Detection (1:yes; 0:no)
0	3	10	95.6	1948	1756	0.186152	1
1	2	10	84.7	1100		1.118208	
2	3	10	97.3	1103	1364	1.358071	
3	2	10	61.4	1642		2.600958	
4	1	10	82.8			2.878895	
5	3	10	85.2	1720	1180	3.642958	
6	3	10	69.6	1287	1069	4.419274	
7	3	10	74.4	1135	1418	5.116611	
8	2	10	86.4	1146		5.782182	
9	2	10	68.2	1012		6.52658	
10	1	10	82.3			7.267696	
11	2	10	66.9	1288		7.361694	
12	3	10	67.4	1650	1735	8.106768	
13	2	10	83.5	1488		9.231589	
14	2	10	90.9	1219		9.656877	
15	2	10	59	1878		10.436818	
16	2	10	74.7	1482		10.905525	
17	2	10	98.4	1305		11.874789	

Bin5 Statistics 12

Trial #	Pulse	Chirp (MHz)	Pulse Width (µS)	Pulse 1-2 spacing (uS)	Pulse 2-3 spacing (uS)	Pulse Start(S)	Detection (1:yes; 0:no)
0	2	19	86.6	1450		0.435152	1
1	3	19	73.2	1327	1919	1.513838	
2	2	19	81.6	1630		2.754389	
3	2	19	91.8	1412		4.761115	
4	3	19	51.5	1462	1212	4.976151	
5	1	19	85.3			6.897614	
6	3	19	64	1777	1323	7.767462	
7	3	19	83.4	1576	1025	9.561773	
8	3	19	54.3	1896	1963	10.11433	
9	2	19	91.6	1905		11.673666	

Bin5 Statistics 13

Trial #	Pulse	Chirp (MHz)	Pulse Width (µS)	Pulse 1-2 spacing (uS)	Pulse 2-3 spacing (uS)	Pulse Start(S)	Detection (1:yes; 0:no)
0	2	8	91.2	1390		0.556495	1
1	1	8	80.8			1.105536	
2	2	8	79.5	1780		1.487156	
3	2	8	95.5	1644		2.090188	
4	2	8	53.9	1458		2.651356	
5	3	8	75.5	1429	1489	3.031677	
6	1	8	75.6			3.922902	
7	2	8	79.4	1753		4.315763	
8	2	8	99.9	1084		4.809877	
9	2	8	67.5	1831		5.580064	
10	1	8	88.5			6.546596	
11	2	8	94.1	1465		6.660835	
12	2	8	81.4	1082		7.472038	
13	2	8	68.7	1974		7.805823	
14	3	8	81.6	1808	1382	8.855441	
15	2	8	85.8	1221		9.320196	
16	1	8	80.2			10.037724	
17	2	8	67.9	1097		10.536548	
18	1	8	51.9			11.09461	
19	1	8	72.5			11.742337	

Bin5 Statistics 14

Trial #	Pulse	Chirp (MHz)	Pulse Width (µS)	Pulse 1-2 spacing (µS)	Pulse 2-3 spacing (µS)	Pulse Start(S)	Detection (1:yes; 0:no)
0	2	11	91.6	1968		0.671879	1
1	1	11	75.1			0.907497	
2	2	11	88.6	1797		2.101645	
3	1	11	58.4			2.776258	
4	2	11	84.4	1424		3.391944	
5	1	11	60			3.979112	
6	3	11	55.2	1866	1956	4.622209	
7	3	11	88.5	1141	1569	5.024958	
8	3	11	93.2	1895	1364	6.151081	
9	3	11	83.2	1038	1141	6.730284	
10	1	11	94.9			7.750073	
11	2	11	71.7	1134		7.973088	
12	3	11	61.7	1477	1799	8.614311	
13	3	11	63.4	1829	1319	9.738538	
14	3	11	89.4	1505	1544	10.045753	
15	3	11	73.4	1371	1325	11.019155	
16	2	11	65.5	1562		11.879545	

Bin5 Statistics 15

Trial #	Pulse	Chirp (MHz)	Pulse Width (µS)	Pulse 1-2 spacing (µS)	Pulse 2-3 spacing (µS)	Pulse Start(S)	Detection (1:yes; 0:no)
0	2	19	97.5	1854		0.515188	1
1	2	19	84.4	1863		1.100832	
2	2	19	61.5	1650		1.943854	
3	1	19	97.8			3.36905	
4	2	19	72	1255		4.101768	
5	2	19	74.4	1739		5.045619	
6	2	19	64.8	1838		6.420984	
7	3	19	77.6	1232	1481	6.593798	
8	1	19	71.8			8.006594	
9	2	19	54.9	1521		8.414611	
10	3	19	96.8	1202	1117	9.483883	
11	1	19	95.6			10.851778	
12	2	19	51.2	1234		11.266572	

Bin5 Statistics 16

Trial #	Pulse	Chirp (MHz)	Pulse Width (µS)	Pulse 1-2 spacing (uS)	Pulse 2-3 spacing (uS)	Pulse Start(S)	Detection (1:yes; 0:no)
0	2	7	98	1031		1.451795	1
1	2	7	64.2	1302		2.2469	
2	1	7	66.1			3.707281	
3	1	7	58.6			4.730949	
4	1	7	88.9			6.959056	
5	1	7	67.9			7.652244	
6	2	7	79.9	1822		9.347789	
7	2	7	88	1696		11.191661	

Bin5 Statistics 17

Trial #	Pulse	Chirp (MHz)	Pulse Width (µS)	Pulse 1-2 spacing (uS)	Pulse 2-3 spacing (uS)	Pulse Start(S)	Detection (1:yes; 0:no)
0	2	5	92.7	1862		0.033077	1
1	2	5	97.6	1472		0.651419	
2	3	5	84.9	1815	1373	1.312335	
3	3	5	60.7	1558	1760	2.234281	
4	2	5	62.2	1774		2.867128	
5	3	5	97.8	1683	1827	3.172613	
6	3	5	90	1690	1034	3.91746	
7	2	5	80.9	1944		4.796881	
8	2	5	75.9	1398		5.456433	
9	2	5	50.7	1635		5.767744	
10	2	5	50	1133		6.913411	
11	2	5	50.4	1063		7.493144	
12	2	5	75.6	1271		7.764425	
13	1	5	60.7			8.361243	
14	2	5	82.8	1577		8.866343	
15	1	5	51.1			9.710242	
16	2	5	96.9	1345		10.705272	
17	1	5	65.2			11.332265	
18	2	5	93.7	1706		11.744994	

Bin5 Statistics 18

Trial #	Pulse	Chirp (MHz)	Pulse Width (µS)	Pulse 1-2 spacing (uS)	Pulse 2-3 spacing (uS)	Pulse Start(S)	Detection (1:yes; 0:no)
0	3	7	76.5	1135	1878	0.519586	1
1	3	7	69.8	1607	1092	1.245077	
2	2	7	83.6	1870		1.788119	
3	3	7	51.9	1699	1478	2.946437	
4	2	7	94.7	1971		3.371645	
5	2	7	92	1120		4.155846	
6	2	7	86	1991		4.73427	
7	2	7	66.7	1227		5.538366	
8	2	7	65.6	1480		6.249538	
9	2	7	92.2	1680		7.144398	
10	2	7	78.2	1260		7.858785	
11	2	7	64.2	1242		8.75549	
12	2	7	79.8	1349		9.307863	
13	1	7	68.6			10.177632	
14	3	7	62	1806	1924	11.007138	
15	2	7	72.9	1592		11.523994	

Bin5 Statistics 19

Trial #	Pulse	Chirp (MHz)	Pulse Width (µS)	Pulse 1-2 spacing (uS)	Pulse 2-3 spacing (uS)	Pulse Start(S)	Detection (1:yes; 0:no)
0	1	11	88.6			0.403304	1
1	2	11	78.2	1640		1.545529	
2	3	11	67.7	1122	1575	2.228185	
3	2	11	63.5	1097		3.379352	
4	1	11	56.9			4.775725	
5	1	11	96.3			5.500277	
6	1	11	87.6			6.872333	
7	2	11	96.6	1810		7.434924	
8	1	11	62.4			8.682091	
9	1	11	79.3			9.988655	
10	1	11	56.3			10.650038	
11	2	11	98.3	1146		11.206868	

Bin5 Statistics 20

Trial #	Pulse	Chirp (MHz)	Pulse Width (µS)	Pulse 1-2 spacing (uS)	Pulse 2-3 spacing (uS)	Pulse Start(S)	Detection (1:yes; 0:no)
0	2	7	59.9	1569		0.134177	1
1	2	7	75.7	1589		0.868825	
2	1	7	61.7			1.283295	
3	3	7	87.6	1839	1365	2.050877	
4	2	7	55.8	1708		2.987168	
5	2	7	50.3	1796		3.564572	
6	2	7	61	1035		3.97674	
7	2	7	95.3	1163		4.728814	
8	2	7	78	1564		5.076383	
9	2	7	88	1183		6.092471	
10	1	7	75.8			6.826157	
11	3	7	57.2	1231	1840	6.969945	
12	2	7	79.6	1217		7.952801	
13	1	7	59.1			8.425682	
14	2	7	75.5	1438		8.908253	
15	2	7	81.9	1437		9.605201	
16	1	7	90.5			10.546593	
17	3	7	71.5	1368	1774	10.872115	
18	1	7	75.2			11.392516	

Bin5 Statistics 21

Trial #	Pulse	Chirp (MHz)	Pulse Width (µS)	Pulse 1-2 spacing (uS)	Pulse 2-3 spacing (uS)	Pulse Start(S)	Detection (1:yes; 0:no)
0	2	17	99.6	1139		0.235445	1
1	2	17	60.6	1543		1.025374	
2	3	17	99.1	1377	1241	1.907521	
3	2	17	57.1	1083		3.423777	
4	2	17	81.2	1749		3.969517	
5	3	17	88.6	1697	1987	4.999508	
6	2	17	75	1272		5.603366	
7	2	17	88.4	1191		6.09175	
8	2	17	70.6	1835		7.021343	
9	2	17	92.5	1696		7.718885	
10	1	17	59			9.102054	
11	1	17	74.8			9.624556	
12	3	17	67.5	1927	1126	11.026377	
13	2	17	70.7	1710		11.562932	

Bin5 Statistics 22

Trial #	Pulse	Chirp (MHz)	Pulse Width (µS)	Pulse 1-2 spacing (uS)	Pulse 2-3 spacing (uS)	Pulse Start(S)	Detection (1:yes; 0:no)
0	2	14	89.7	1172		0.430944	1
1	3	14	86	1470	1831	0.883499	
2	2	14	98.2	1180		1.617543	
3	1	14	67.7			2.006818	
4	1	14	93.3			3.062161	
5	3	14	92.2	1730	1801	3.738804	
6	3	14	72.3	1374	1524	4.270985	
7	3	14	76.2	1449	1387	4.912687	
8	3	14	99	1474	1889	5.423406	
9	2	14	67.3	1483		6.606422	
10	2	14	85.6	1175		6.907035	
11	2	14	87.5	1079		7.890063	
12	1	14	51.8			8.242506	
13	1	14	70.5			9.003883	
14	2	14	99.5	1919		9.370621	
15	1	14	53.3			10.112141	
16	3	14	79.8	1611	1079	10.892006	
17	2	14	92.8	1407		11.42467	

Bin5 Statistics 23

Trial #	Pulse	Chirp (MHz)	Pulse Width (µS)	Pulse 1-2 spacing (uS)	Pulse 2-3 spacing (uS)	Pulse Start(S)	Detection (1:yes; 0:no)
0	3	19	52.9	1154	1545	0.489097	1
1	1	19	55.3			1.240606	
2	2	19	66.1	1107		2.124033	
3	2	19	81	1170		3.637351	
4	2	19	62.4	1319		4.267272	
5	2	19	60.9	1606		5.086879	
6	2	19	74.2	1698		6.843017	
7	2	19	80.3	1884		7.257457	
8	1	19	95.8			8.957278	
9	2	19	57	1311		9.43381	
10	3	19	57.9	1664	1796	10.327294	
11	2	19	52.2	1106		11.922732	

Bin5 Statistics 24

Trial #	Pulse	Chirp (MHz)	Pulse Width (µS)	Pulse 1-2 spacing (uS)	Pulse 2-3 spacing (uS)	Pulse Start(S)	Detection (1:yes; 0:no)
0	3	11	55.9	1921	1294	0.264011	1
1	2	11	90.7	1891		0.787784	
2	3	11	70.5	1061	1872	1.377732	
3	3	11	69.1	1638	1457	2.425464	
4	3	11	86.4	1691	1436	3.139544	
5	3	11	90.9	1918	1079	3.736656	
6	2	11	59.7	1806		3.9609	
7	3	11	64.2	1360	1863	4.434946	
8	3	11	53.1	1427	1710	5.353173	
9	1	11	67.1			5.753996	
10	2	11	51.9	1172		6.597926	
11	2	11	80.5	1606		7.179246	
12	2	11	64.4	1933		7.622853	
13	2	11	50.6	1384		8.799547	
14	3	11	98	1908	1212	8.884378	
15	3	11	86.1	1192	1336	9.853544	
16	2	11	92.9	1298		10.149726	
17	1	11	81.5			11.136329	
18	1	11	95.8			11.963905	

Bin5 Statistics 25

Trial #	Pulse	Chirp (MHz)	Pulse Width (µS)	Pulse 1-2 spacing (uS)	Pulse 2-3 spacing (uS)	Pulse Start(S)	Detection (1:yes; 0:no)
0	3	8	94.3	1635	1576	0.12021	1
1	1	8	59.8			1.223369	
2	1	8	79			1.726597	
3	3	8	75.6	1764	1142	2.937605	
4	1	8	88.2			4.274522	
5	2	8	85.7	1994		4.869833	
6	2	8	98.5	1323		5.931414	
7	2	8	76.7	1091		6.766521	
8	2	8	56.1	1693		7.697948	
9	2	8	69.8	1638		8.073981	
10	2	8	67.1	1370		9.225335	
11	1	8	77.7			9.956234	
12	2	8	86	2000		10.362499	
13	1	8	79.4			11.300575	

Bin5 Statistics 26

Trial #	Pulse	Chirp (MHz)	Pulse Width (µS)	Pulse 1-2 spacing (uS)	Pulse 2-3 spacing (uS)	Pulse Start(S)	Detection (1:yes; 0:no)
0	3	20	97.9	1597	1191	0.479778	1
1	3	20	98	1807	1347	1.045174	
2	2	20	76.1	1896		1.65104	
3	2	20	97.4	1403		2.894008	
4	1	20	59.6			3.527423	
5	3	20	97.9	1103	1554	4.702818	
6	2	20	50.9	1666		4.835464	
7	2	20	75.5	1178		5.933761	
8	1	20	67.8			7.016738	
9	3	20	99.5	1324	1301	7.613574	
10	2	20	54.1	1419		8.223737	
11	2	20	79.9	1150		8.997353	
12	2	20	62	1898		9.734287	
13	1	20	61.4			10.434861	
14	2	20	88.6	1018		11.914119	

Bin5 Statistics 27

Trial #	Pulse	Chirp (MHz)	Pulse Width (µS)	Pulse 1-2 spacing (uS)	Pulse 2-3 spacing (uS)	Pulse Start(S)	Detection (1:yes; 0:no)
0	1	5	78.8			0.140613	1
1	1	5	97.4			1.371745	
2	3	5	79.4	1920	1230	1.544926	
3	1	5	87.2			2.936532	
4	1	5	90.9			3.593904	
5	2	5	78.5	1018		4.36714	
6	3	5	82.8	1534	1617	4.527911	
7	2	5	79.5	1588		5.855643	
8	2	5	94.2	1238		6.395864	
9	3	5	56.3	1117	1310	7.466901	
10	2	5	51.8	1484		8.150903	
11	2	5	95.7	1718		8.341256	
12	2	5	96.1	1623		9.262514	
13	2	5	97.9	1863		10.214257	
14	2	5	59.1	1600		11.052911	
15	2	5	77.9	1197		11.453052	

Bin5 Statistics 28

Trial #	Pulse	Chirp (MHz)	Pulse Width (µS)	Pulse 1-2 spacing (uS)	Pulse 2-3 spacing (uS)	Pulse Start(S)	Detection (1:yes; 0:no)
0	1	9	58.4			1.047109	1
1	2	9	93.2	1325		2.204175	
2	1	9	62.9			3.910779	
3	3	9	51.2	1575	1513	4.971396	
4	2	9	93.9	1729		6.396205	
5	2	9	80.1	1407		6.911587	
6	1	9	80.7			8.860073	
7	3	9	76.4	1834	1707	10.34785	
8	2	9	71.5	1189		11.369603	

Bin5 Statistics 29

Trial #	Pulse	Chirp (MHz)	Pulse Width (µS)	Pulse 1-2 spacing (uS)	Pulse 2-3 spacing (uS)	Pulse Start(S)	Detection (1:yes; 0:no)
0	2	6	87.9	1220		0.516678	1
1	2	6	80.3	1348		1.08818	
2	2	6	92.1	1702		1.472949	
3	2	6	79.5	1611		2.348029	
4	2	6	85.2	1089		3.146479	
5	3	6	55	1360	1597	3.954774	
6	2	6	86.7	1561		4.73063	
7	3	6	73.3	1995	1791	5.202336	
8	3	6	91.7	1308	1639	5.955799	
9	3	6	98.4	1086	1527	6.900679	
10	1	6	51.8			7.194472	
11	2	6	96.2	1768		7.871269	
12	1	6	75.8			9.024375	
13	1	6	64.7			9.675629	
14	1	6	73.4			10.08382	
15	2	6	80.4	1134		11.109272	
16	2	6	72.1	1924		11.843746	

Bin5 Statistics 30

Trial #	Pulse	Chirp (MHz)	Pulse Width (µS)	Pulse 1-2 spacing (uS)	Pulse 2-3 spacing (uS)	Pulse Start(S)	Detection (1:yes; 0:no)
0	3	15	92.9	1087	1323	0.211412	1
1	2	15	89.8	1822		1.174791	
2	1	15	62.2			1.592956	
3	2	15	57.4	1251		2.31309	
4	1	15	64.1			3.285825	
5	3	15	98.7	1070	1105	3.75744	
6	1	15	58			4.660878	
7	2	15	66.9	1226		5.006485	
8	2	15	52.5	1239		5.930897	
9	3	15	81.7	1768	1267	6.630386	
10	2	15	55	1260		7.285856	
11	3	15	54.5	1374	1972	7.927628	
12	2	15	99	1820		8.064578	
13	2	15	68.3	1691		8.993165	
14	2	15	63.9	1779		9.819525	
15	2	15	84.5	1931		10.473668	
16	2	15	75.3	1651		11.236293	
17	1	15	83.2			11.78026	

Table-6 Radar Type 6 Statistical Performance

Trial #	Fc (MHz)	Pulse /Burst	Pulse Width (µS)	PRI (µs)	Detection (1:yes; 0:no)	Hopping Sequence
1	5490	9	1	333	1	5515.0, 5328.0, 5307.0, 5724.0, 5295.0, 5361.0, 5666.0, 5477.0, 5371.0, 5396.0, 5291.0, 5654.0, 5598.0, 5310.0, 5350.0, 5677.0, 5348.0, 5701.0, 5326.0, 5333.0, 5645.0, 5311.0, 5585.0, 5463.0, 5707.0, 5511.0, 5557.0, 5714.0, 5693.0, 5450.0, 5293.0, 5704.0, 5540.0, 5705.0, 5409.0, 5458.0, 5278.0, 5575.0, 5460.0, 5573.0, 5544.0, 5636.0, 5556.0, 5547.0, 5312.0, 5695.0, 5651.0, 5590.0, 5550.0, 5453.0, 5665.0, 5462.0, 5478.0, 5597.0, 5268.0, 5558.0, 5314.0, 5283.0, 5446.0, 5571.0, 5317.0, 5265.0, 5700.0, 5303.0, 5426.0, 5480.0, 5380.0, 5662.0, 5552.0, 5494.0, 5412.0, 5280.0, 5308.0, 5537.0, 5493.0, 5403.0, 5690.0, 5337.0, 5395.0, 5567.0, 5643.0, 5413.0, 5689.0, 5469.0, 5644.0, 5362.0, 5343.0, 5378.0, 5437.0, 5621.0, 5664.0, 5570.0, 5322.0, 5391.0, 5346.0, 5252.0, 5579.0, 5432.0, 5499.0, 5663.0 (number of hits: 15)
2	5490	9	1	333	1	5387.0, 5662.0, 5479.0, 5468.0, 5683.0, 5352.0, 5670.0, 5638.0, 5302.0, 5439.0, 5712.0, 5368.0, 5475.0, 5346.0, 5594.0, 5308.0, 5393.0, 5562.0, 5687.0, 5700.0, 5437.0, 5273.0, 5637.0, 5578.0, 5355.0, 5422.0, 5708.0, 5552.0, 5492.0, 5668.0, 5666.0, 5254.0, 5582.0, 5588.0, 5306.0, 5263.0, 5347.0, 5403.0, 5364.0, 5312.0, 5400.0, 5525.0, 5354.0, 5586.0, 5646.0, 5380.0, 5351.0, 5622.0, 5436.0, 5304.0, 5652.0, 5645.0, 5675.0, 5474.0, 5265.0, 5723.0, 5332.0, 5269.0, 5676.0, 5412.0, 5518.0, 5591.0, 5453.0, 5381.0, 5459.0, 5341.0, 5363.0, 5509.0, 5266.0, 5714.0, 5343.0, 5494.0, 5267.0, 5674.0, 5489.0, 5501.0, 5539.0, 5404.0, 5337.0, 5455.0, 5375.0, 5357.0, 5444.0, 5506.0, 5280.0, 5698.0, 5507.0, 5611.0, 5654.0, 5573.0, 5671.0, 5640.0, 5309.0, 5589.0, 5322.0, 5326.0, 5327.0, 5333.0, 5278.0, 5294.0 (number of hits: 16)
3	5490	9	1	333	1	5649.0, 5613.0, 5584.0, 5709.0, 5463.0, 5717.0, 5460.0, 5724.0, 5266.0, 5381.0, 5373.0, 5641.0, 5554.0, 5503.0, 5558.0, 5611.0, 5556.0, 5376.0, 5311.0, 5574.0, 5655.0, 5262.0, 5329.0, 5481.0, 5573.0, 5473.0, 5525.0, 5618.0, 5297.0, 5617.0, 5596.0, 5652.0, 5605.0, 5610.0, 5264.0, 5397.0, 5356.0, 5363.0, 5663.0, 5257.0, 5321.0, 5585.0, 5628.0, 5632.0, 5658.0, 5318.0, 5484.0, 5368.0, 5299.0, 5323.0, 5523.0, 5545.0, 5559.0, 5306.0, 5598.0, 5375.0, 5502.0, 5285.0, 5483.0, 5444.0, 5355.0, 5328.0, 5431.0, 5679.0, 5662.0,

						5352.0, 5665.0, 5392.0, 5334.0, 5660.0, 5475.0, 5474.0, 5562.0, 5466.0, 5387.0, 5674.0, 5462.0, 5690.0, 5303.0, 5508.0, 5603.0, 5268.0, 5337.0, 5419.0, 5677.0, 5294.0, 5336.0, 5290.0, 5631.0, 5615.0, 5626.0, 5437.0, 5553.0, 5576.0, 5452.0, 5316.0, 5287.0, 5491.0, 5317.0, 5697.0 (number of hits: 17)
4	5490	9	1	333	1	5636.0, 5614.0, 5507.0, 5307.0, 5425.0, 5708.0, 5343.0, 5605.0, 5477.0, 5603.0, 5582.0, 5568.0, 5409.0, 5365.0, 5446.0, 5646.0, 5385.0, 5622.0, 5460.0, 5696.0, 5679.0, 5526.0, 5488.0, 5434.0, 5257.0, 5535.0, 5517.0, 5260.0, 5620.0, 5652.0, 5561.0, 5692.0, 5589.0, 5631.0, 5394.0, 5449.0, 5431.0, 5465.0, 5546.0, 5433.0, 5252.0, 5323.0, 5490.0, 5483.0, 5600.0, 5380.0, 5487.0, 5677.0, 5577.0, 5609.0, 5591.0, 5467.0, 5686.0, 5292.0, 5506.0, 5354.0, 5281.0, 5619.0, 5418.0, 5509.0, 5655.0, 5719.0, 5644.0, 5683.0, 5480.0, 5592.0, 5662.0, 5691.0, 5593.0, 5452.0, 5361.0, 5276.0, 5479.0, 5541.0, 5266.0, 5693.0, 5414.0, 5435.0, 5618.0, 5684.0, 5654.0, 5275.0, 5429.0, 5284.0, 5289.0, 5382.0, 5298.0, 5297.0, 5457.0, 5667.0, 5607.0, 5315.0, 5451.0, 5291.0, 5478.0, 5537.0, 5412.0, 5544.0, 5318.0, 5454.0 (number of hits: 20)
5	5490	9	1	333	1	5381.0, 5295.0, 5366.0, 5722.0, 5707.0, 5538.0, 5272.0, 5407.0, 5400.0, 5714.0, 5563.0, 5685.0, 5257.0, 5711.0, 5444.0, 5317.0, 5285.0, 5387.0, 5448.0, 5651.0, 5460.0, 5515.0, 5705.0, 5640.0, 5419.0, 5591.0, 5261.0, 5445.0, 5695.0, 5379.0, 5342.0, 5466.0, 5537.0, 5274.0, 5699.0, 5303.0, 5716.0, 5470.0, 5271.0, 5542.0, 5461.0, 5608.0, 5717.0, 5415.0, 5560.0, 5646.0, 5602.0, 5422.0, 5634.0, 5432.0, 5688.0, 5392.0, 5298.0, 5721.0, 5550.0, 5613.0, 5293.0, 5425.0, 5528.0, 5313.0, 5562.0, 5696.0, 5369.0, 5670.0, 5414.0, 5499.0, 5260.0, 5357.0, 5682.0, 5454.0, 5273.0, 5557.0, 5418.0, 5660.0, 5316.0, 5583.0, 5289.0, 5437.0, 5408.0, 5258.0, 5495.0, 5441.0, 5603.0, 5659.0, 5532.0, 5475.0, 5649.0, 5489.0, 5554.0, 5399.0, 5356.0, 5596.0, 5681.0, 5641.0, 5388.0, 5582.0, 5401.0, 5319.0, 5352.0, 5290.0 (number of hits: 11)
6	5490	9	1	333	1	5325.0, 5428.0, 5287.0, 5263.0, 5319.0, 5254.0, 5579.0, 5488.0, 5285.0, 5436.0, 5696.0, 5460.0, 5269.0, 5340.0, 5454.0, 5623.0, 5705.0, 5528.0, 5693.0, 5492.0, 5578.0, 5680.0, 5650.0, 5364.0, 5560.0, 5484.0, 5662.0, 5331.0, 5504.0, 5373.0, 5698.0, 5692.0, 5535.0, 5349.0, 5407.0, 5402.0, 5472.0, 5481.0, 5482.0, 5348.0, 5315.0, 5453.0, 5332.0, 5275.0, 5660.0, 5429.0, 5463.0, 5346.0, 5570.0, 5403.0, 5716.0, 5665.0, 5264.0, 5690.0, 5587.0,

						5343.0, 5501.0, 5593.0, 5286.0, 5671.0, 5449.0, 5483.0, 5718.0, 5648.0, 5307.0, 5361.0, 5369.0, 5461.0, 5267.0, 5715.0, 5666.0, 5704.0, 5541.0, 5379.0, 5637.0, 5400.0, 5614.0, 5337.0, 5685.0, 5258.0, 5583.0, 5569.0, 5694.0, 5629.0, 5610.0, 5279.0, 5613.0, 5392.0, 5310.0, 5521.0, 5491.0, 5678.0, 5313.0, 5261.0, 5324.0, 5320.0, 5271.0, 5524.0, 5606.0, 5658.0 (number of hits: 18)
7	5490	9	1	333	1	5582.0, 5645.0, 5678.0, 5472.0, 5281.0, 5626.0, 5408.0, 5632.0, 5575.0, 5554.0, 5681.0, 5294.0, 5404.0, 5674.0, 5435.0, 5629.0, 5500.0, 5529.0, 5366.0, 5585.0, 5323.0, 5477.0, 5385.0, 5494.0, 5420.0, 5587.0, 5682.0, 5532.0, 5631.0, 5370.0, 5549.0, 5436.0, 5495.0, 5343.0, 5257.0, 5439.0, 5368.0, 5283.0, 5625.0, 5540.0, 5395.0, 5506.0, 5446.0, 5683.0, 5660.0, 5418.0, 5488.0, 5687.0, 5319.0, 5607.0, 5411.0, 5467.0, 5605.0, 5341.0, 5614.0, 5338.0, 5690.0, 5561.0, 5537.0, 5649.0, 5661.0, 5475.0, 5544.0, 5612.0, 5603.0, 5454.0, 5282.0, 5286.0, 5633.0, 5390.0, 5325.0, 5377.0, 5552.0, 5658.0, 5330.0, 5553.0, 5701.0, 5515.0, 5619.0, 5673.0, 5615.0, 5262.0, 5608.0, 5329.0, 5588.0, 5592.0, 5502.0, 5613.0, 5447.0, 5579.0, 5301.0, 5703.0, 5686.0, 5556.0, 5567.0, 5355.0, 5627.0, 5392.0, 5331.0, 5328.0 (number of hits: 13)
8	5490	9	1	333	1	5455.0, 5693.0, 5297.0, 5481.0, 5546.0, 5485.0, 5662.0, 5275.0, 5468.0, 5618.0, 5691.0, 5411.0, 5594.0, 5715.0, 5389.0, 5408.0, 5479.0, 5265.0, 5262.0, 5477.0, 5610.0, 5509.0, 5586.0, 5365.0, 5527.0, 5706.0, 5526.0, 5383.0, 5718.0, 5432.0, 5370.0, 5346.0, 5591.0, 5494.0, 5704.0, 5294.0, 5659.0, 5664.0, 5539.0, 5710.0, 5436.0, 5623.0, 5369.0, 5440.0, 5264.0, 5686.0, 5622.0, 5520.0, 5596.0, 5590.0, 5538.0, 5498.0, 5646.0, 5298.0, 5703.0, 5478.0, 5557.0, 5409.0, 5339.0, 5569.0, 5626.0, 5302.0, 5503.0, 5597.0, 5423.0, 5515.0, 5516.0, 5554.0, 5537.0, 5446.0, 5363.0, 5612.0, 5525.0, 5307.0, 5465.0, 5499.0, 5524.0, 5655.0, 5671.0, 5630.0, 5301.0, 5547.0, 5325.0, 5443.0, 5271.0, 5291.0, 5268.0, 5434.0, 5699.0, 5716.0, 5679.0, 5420.0, 5687.0, 5692.0, 5277.0, 5441.0, 5632.0, 5491.0, 5390.0, 5352.0 (number of hits: 21)
9	5490	9	1	333	1	5697.0, 5255.0, 5604.0, 5451.0, 5414.0, 5413.0, 5565.0, 5332.0, 5546.0, 5636.0, 5530.0, 5696.0, 5563.0, 5577.0, 5674.0, 5572.0, 5436.0, 5647.0, 5458.0, 5645.0, 5327.0, 5579.0, 5321.0, 5354.0, 5293.0, 5292.0, 5506.0, 5498.0, 5417.0, 5392.0, 5709.0, 5477.0, 5366.0, 5300.0, 5309.0, 5510.0, 5639.0, 5342.0, 5298.0, 5415.0, 5310.0, 5655.0, 5700.0, 5638.0, 5361.0,

						5389.0, 5440.0, 5365.0, 5597.0, 5437.0, 5336.0, 5542.0, 5262.0, 5544.0, 5694.0, 5324.0, 5482.0, 5402.0, 5516.0, 5517.0, 5483.0, 5409.0, 5279.0, 5412.0, 5665.0, 5263.0, 5593.0, 5382.0, 5649.0, 5261.0, 5479.0, 5273.0, 5714.0, 5407.0, 5716.0, 5557.0, 5673.0, 5349.0, 5288.0, 5396.0, 5322.0, 5358.0, 5431.0, 5492.0, 5456.0, 5666.0, 5367.0, 5653.0, 5408.0, 5549.0, 5272.0, 5496.0, 5501.0, 5394.0, 5370.0, 5347.0, 5277.0, 5467.0, 5567.0, 5560.0 (number of hits: 16)
10	5490	9	1	333	1	5659.0, 5264.0, 5690.0, 5696.0, 5608.0, 5312.0, 5540.0, 5716.0, 5412.0, 5703.0, 5302.0, 5484.0, 5380.0, 5476.0, 5689.0, 5253.0, 5548.0, 5710.0, 5382.0, 5536.0, 5304.0, 5552.0, 5469.0, 5332.0, 5514.0, 5346.0, 5454.0, 5512.0, 5697.0, 5443.0, 5280.0, 5702.0, 5551.0, 5688.0, 5614.0, 5486.0, 5329.0, 5338.0, 5323.0, 5447.0, 5694.0, 5435.0, 5416.0, 5308.0, 5562.0, 5432.0, 5658.0, 5449.0, 5655.0, 5493.0, 5444.0, 5305.0, 5580.0, 5360.0, 5553.0, 5363.0, 5706.0, 5428.0, 5396.0, 5268.0, 5581.0, 5285.0, 5533.0, 5567.0, 5650.0, 5629.0, 5525.0, 5337.0, 5597.0, 5306.0, 5334.0, 5720.0, 5322.0, 5336.0, 5335.0, 5478.0, 5668.0, 5286.0, 5501.0, 5287.0, 5603.0, 5379.0, 5575.0, 5319.0, 5410.0, 5704.0, 5445.0, 5459.0, 5284.0, 5300.0, 5518.0, 5261.0, 5283.0, 5345.0, 5344.0, 5309.0, 5297.0, 5372.0, 5656.0, 5646.0 (number of hits: 13)
11	5530	9	1	333	1	5343.0, 5634.0, 5270.0, 5706.0, 5486.0, 5278.0, 5322.0, 5534.0, 5397.0, 5364.0, 5350.0, 5526.0, 5362.0, 5380.0, 5627.0, 5550.0, 5385.0, 5658.0, 5511.0, 5462.0, 5718.0, 5390.0, 5588.0, 5593.0, 5650.0, 5387.0, 5481.0, 5306.0, 5289.0, 5553.0, 5476.0, 5605.0, 5615.0, 5381.0, 5651.0, 5460.0, 5401.0, 5590.0, 5677.0, 5562.0, 5500.0, 5461.0, 5632.0, 5640.0, 5589.0, 5501.0, 5521.0, 5557.0, 5663.0, 5618.0, 5545.0, 5351.0, 5624.0, 5527.0, 5516.0, 5312.0, 5496.0, 5315.0, 5488.0, 5437.0, 5456.0, 5297.0, 5467.0, 5300.0, 5342.0, 5479.0, 5257.0, 5334.0, 5710.0, 5628.0, 5464.0, 5659.0, 5714.0, 5314.0, 5301.0, 5296.0, 5325.0, 5470.0, 5405.0, 5369.0, 5451.0, 5669.0, 5442.0, 5474.0, 5581.0, 5416.0, 5307.0, 5723.0, 5477.0, 5686.0, 5655.0, 5279.0, 5463.0, 5321.0, 5286.0, 5402.0, 5328.0, 5349.0, 5645.0, 5473.0 (number of hits: 14)
12	5530	9	1	333	1	5519.0, 5541.0, 5512.0, 5637.0, 5639.0, 5377.0, 5255.0, 5543.0, 5452.0, 5617.0, 5485.0, 5312.0, 5477.0, 5516.0, 5675.0, 5650.0, 5700.0, 5390.0, 5391.0, 5590.0, 5408.0, 5654.0, 5723.0, 5365.0, 5340.0, 5582.0, 5574.0, 5522.0, 5432.0, 5397.0, 5517.0, 5265.0, 5651.0, 5375.0, 5682.0,

						5673.0, 5539.0, 5423.0, 5545.0, 5525.0, 5604.0, 5361.0, 5614.0, 5420.0, 5296.0, 5257.0, 5529.0, 5416.0, 5507.0, 5580.0, 5387.0, 5479.0, 5453.0, 5649.0, 5623.0, 5520.0, 5324.0, 5349.0, 5693.0, 5281.0, 5362.0, 5439.0, 5403.0, 5524.0, 5636.0, 5287.0, 5631.0, 5659.0, 5424.0, 5347.0, 5592.0, 5436.0, 5307.0, 5657.0, 5451.0, 5438.0, 5413.0, 5384.0, 5493.0, 5596.0, 5635.0, 5701.0, 5285.0, 5398.0, 5500.0, 5527.0, 5355.0, 5573.0, 5446.0, 5269.0, 5468.0, 5570.0, 5670.0, 5708.0, 5321.0, 5369.0, 5358.0, 5501.0, 5447.0, 5490.0 (number of hits: 19)
13	5530	9	1	333	1	5399.0, 5602.0, 5380.0, 5515.0, 5501.0, 5693.0, 5607.0, 5639.0, 5527.0, 5638.0, 5289.0, 5695.0, 5701.0, 5617.0, 5306.0, 5262.0, 5332.0, 5258.0, 5662.0, 5578.0, 5405.0, 5547.0, 5347.0, 5709.0, 5443.0, 5544.0, 5655.0, 5409.0, 5419.0, 5526.0, 5354.0, 5450.0, 5506.0, 5363.0, 5338.0, 5283.0, 5312.0, 5536.0, 5360.0, 5529.0, 5689.0, 5388.0, 5305.0, 5589.0, 5576.0, 5596.0, 5342.0, 5288.0, 5670.0, 5395.0, 5392.0, 5566.0, 5261.0, 5714.0, 5707.0, 5556.0, 5495.0, 5505.0, 5533.0, 5660.0, 5421.0, 5552.0, 5710.0, 5518.0, 5694.0, 5522.0, 5656.0, 5565.0, 5365.0, 5558.0, 5268.0, 5528.0, 5677.0, 5696.0, 5539.0, 5546.0, 5252.0, 5681.0, 5390.0, 5469.0, 5582.0, 5394.0, 5722.0, 5451.0, 5597.0, 5560.0, 5371.0, 5586.0, 5537.0, 5486.0, 5368.0, 5315.0, 5569.0, 5446.0, 5384.0, 5424.0, 5640.0, 5284.0, 5275.0, 5591.0 (number of hits: 25)
14	5530	9	1	333	1	5536.0, 5605.0, 5700.0, 5395.0, 5467.0, 5404.0, 5366.0, 5715.0, 5717.0, 5315.0, 5514.0, 5399.0, 5657.0, 5573.0, 5286.0, 5483.0, 5490.0, 5438.0, 5499.0, 5626.0, 5711.0, 5350.0, 5618.0, 5274.0, 5345.0, 5254.0, 5352.0, 5312.0, 5704.0, 5384.0, 5422.0, 5263.0, 5265.0, 5468.0, 5510.0, 5611.0, 5651.0, 5635.0, 5278.0, 5338.0, 5520.0, 5609.0, 5608.0, 5524.0, 5580.0, 5682.0, 5598.0, 5587.0, 5599.0, 5712.0, 5667.0, 5363.0, 5708.0, 5460.0, 5517.0, 5493.0, 5401.0, 5340.0, 5270.0, 5461.0, 5676.0, 5697.0, 5640.0, 5346.0, 5506.0, 5272.0, 5393.0, 5692.0, 5386.0, 5298.0, 5498.0, 5723.0, 5488.0, 5505.0, 5544.0, 5581.0, 5634.0, 5439.0, 5707.0, 5719.0, 5480.0, 5686.0, 5656.0, 5279.0, 5665.0, 5572.0, 5694.0, 5376.0, 5542.0, 5537.0, 5383.0, 5283.0, 5261.0, 5509.0, 5405.0, 5369.0, 5622.0, 5406.0, 5695.0, 5487.0 (number of hits: 16)
15	5530	9	1	333	1	5303.0, 5540.0, 5518.0, 5549.0, 5565.0, 5713.0, 5557.0, 5447.0, 5651.0, 5424.0, 5530.0, 5578.0, 5492.0, 5539.0, 5661.0, 5322.0, 5677.0, 5498.0, 5259.0, 5320.0, 5676.0, 5344.0, 5716.0, 5690.0, 5383.0,

						5526.0, 5371.0, 5542.0, 5640.0, 5298.0, 5279.0, 5480.0, 5576.0, 5669.0, 5281.0, 5692.0, 5358.0, 5462.0, 5513.0, 5577.0, 5292.0, 5366.0, 5339.0, 5325.0, 5398.0, 5568.0, 5501.0, 5714.0, 5324.0, 5435.0, 5595.0, 5619.0, 5396.0, 5333.0, 5521.0, 5405.0, 5696.0, 5606.0, 5411.0, 5313.0, 5393.0, 5423.0, 5266.0, 5297.0, 5666.0, 5664.0, 5569.0, 5454.0, 5481.0, 5290.0, 5485.0, 5653.0, 5552.0, 5581.0, 5261.0, 5369.0, 5418.0, 5555.0, 5256.0, 5349.0, 5668.0, 5721.0, 5638.0, 5257.0, 5483.0, 5723.0, 5364.0, 5428.0, 5698.0, 5368.0, 5563.0, 5560.0, 5389.0, 5654.0, 5326.0, 5529.0, 5613.0, 5437.0, 5479.0, 5433.0 (number of hits: 21)
16	5530	9	1	333	1	5408.0, 5305.0, 5387.0, 5315.0, 5299.0, 5361.0, 5449.0, 5714.0, 5284.0, 5553.0, 5640.0, 5446.0, 5448.0, 5667.0, 5379.0, 5437.0, 5632.0, 5551.0, 5401.0, 5719.0, 5397.0, 5383.0, 5355.0, 5546.0, 5488.0, 5526.0, 5516.0, 5677.0, 5678.0, 5370.0, 5321.0, 5558.0, 5599.0, 5565.0, 5631.0, 5638.0, 5352.0, 5485.0, 5629.0, 5435.0, 5567.0, 5592.0, 5649.0, 5467.0, 5536.0, 5275.0, 5295.0, 5693.0, 5614.0, 5462.0, 5326.0, 5580.0, 5668.0, 5428.0, 5586.0, 5421.0, 5366.0, 5628.0, 5425.0, 5285.0, 5596.0, 5612.0, 5393.0, 5267.0, 5669.0, 5463.0, 5298.0, 5717.0, 5624.0, 5250.0, 5290.0, 5281.0, 5594.0, 5418.0, 5525.0, 5576.0, 5473.0, 5380.0, 5369.0, 5660.0, 5482.0, 5278.0, 5665.0, 5417.0, 5523.0, 5375.0, 5279.0, 5342.0, 5257.0, 5700.0, 5524.0, 5657.0, 5499.0, 5723.0, 5400.0, 5274.0, 5685.0, 5695.0, 5293.0, 5412.0 (number of hits: 13)
17	5530	9	1	333	1	5344.0, 5588.0, 5278.0, 5703.0, 5534.0, 5639.0, 5283.0, 5501.0, 5388.0, 5585.0, 5499.0, 5667.0, 5706.0, 5665.0, 5717.0, 5320.0, 5657.0, 5536.0, 5487.0, 5327.0, 5364.0, 5366.0, 5686.0, 5437.0, 5391.0, 5500.0, 5705.0, 5695.0, 5367.0, 5605.0, 5636.0, 5617.0, 5383.0, 5538.0, 5343.0, 5528.0, 5412.0, 5529.0, 5403.0, 5385.0, 5329.0, 5623.0, 5301.0, 5280.0, 5511.0, 5368.0, 5396.0, 5439.0, 5468.0, 5347.0, 5618.0, 5537.0, 5326.0, 5483.0, 5522.0, 5584.0, 5313.0, 5607.0, 5352.0, 5604.0, 5336.0, 5354.0, 5442.0, 5631.0, 5516.0, 5303.0, 5464.0, 5660.0, 5263.0, 5597.0, 5324.0, 5512.0, 5416.0, 5662.0, 5474.0, 5648.0, 5478.0, 5715.0, 5669.0, 5469.0, 5699.0, 5524.0, 5386.0, 5518.0, 5658.0, 5256.0, 5684.0, 5652.0, 5332.0, 5672.0, 5661.0, 5712.0, 5616.0, 5421.0, 5296.0, 5300.0, 5339.0, 5440.0, 5292.0, 5373.0 (number of hits: 15)
18	5530	9	1	333	1	5486.0, 5298.0, 5409.0, 5446.0, 5675.0, 5601.0, 5388.0, 5331.0, 5393.0, 5499.0, 5671.0, 5524.0, 5617.0, 5256.0, 5305.0,

						5417.0, 5716.0, 5396.0, 5445.0, 5483.0, 5413.0, 5340.0, 5706.0, 5497.0, 5621.0, 5632.0, 5604.0, 5538.0, 5591.0, 5391.0, 5575.0, 5352.0, 5267.0, 5411.0, 5723.0, 5420.0, 5336.0, 5527.0, 5657.0, 5568.0, 5600.0, 5404.0, 5613.0, 5488.0, 5421.0, 5677.0, 5320.0, 5506.0, 5633.0, 5567.0, 5631.0, 5590.0, 5697.0, 5668.0, 5261.0, 5350.0, 5549.0, 5338.0, 5435.0, 5672.0, 5718.0, 5358.0, 5255.0, 5378.0, 5281.0, 5509.0, 5522.0, 5344.0, 5310.0, 5433.0, 5491.0, 5469.0, 5399.0, 5637.0, 5512.0, 5558.0, 5405.0, 5406.0, 5570.0, 5270.0, 5459.0, 5271.0, 5508.0, 5292.0, 5412.0, 5389.0, 5620.0, 5694.0, 5400.0, 5454.0, 5624.0, 5517.0, 5282.0, 5712.0, 5510.0, 5695.0, 5394.0, 5638.0, 5323.0, 5667.0 (number of hits: 17)
19	5530	9	1	333	1	5684.0, 5282.0, 5615.0, 5268.0, 5507.0, 5724.0, 5302.0, 5432.0, 5298.0, 5650.0, 5512.0, 5574.0, 5351.0, 5289.0, 5585.0, 5434.0, 5255.0, 5560.0, 5680.0, 5470.0, 5323.0, 5251.0, 5720.0, 5681.0, 5377.0, 5626.0, 5535.0, 5318.0, 5645.0, 5710.0, 5610.0, 5444.0, 5663.0, 5508.0, 5253.0, 5495.0, 5486.0, 5316.0, 5683.0, 5325.0, 5506.0, 5270.0, 5475.0, 5271.0, 5399.0, 5657.0, 5678.0, 5293.0, 5389.0, 5489.0, 5384.0, 5662.0, 5648.0, 5455.0, 5579.0, 5656.0, 5487.0, 5400.0, 5410.0, 5333.0, 5319.0, 5388.0, 5534.0, 5634.0, 5623.0, 5554.0, 5413.0, 5312.0, 5345.0, 5299.0, 5711.0, 5478.0, 5436.0, 5336.0, 5682.0, 5283.0, 5428.0, 5698.0, 5344.0, 5665.0, 5337.0, 5466.0, 5391.0, 5453.0, 5342.0, 5688.0, 5550.0, 5505.0, 5424.0, 5563.0, 5611.0, 5386.0, 5559.0, 5266.0, 5520.0, 5583.0, 5290.0, 5545.0, 5257.0, 5639.0 (number of hits: 15)
20	5530	9	1	333	1	5607.0, 5361.0, 5484.0, 5446.0, 5437.0, 5326.0, 5561.0, 5701.0, 5475.0, 5289.0, 5278.0, 5424.0, 5286.0, 5434.0, 5367.0, 5638.0, 5533.0, 5360.0, 5302.0, 5435.0, 5427.0, 5689.0, 5300.0, 5628.0, 5480.0, 5584.0, 5284.0, 5616.0, 5609.0, 5436.0, 5408.0, 5541.0, 5659.0, 5393.0, 5574.0, 5568.0, 5306.0, 5462.0, 5279.0, 5397.0, 5453.0, 5379.0, 5716.0, 5562.0, 5643.0, 5401.0, 5366.0, 5392.0, 5343.0, 5503.0, 5488.0, 5721.0, 5546.0, 5432.0, 5631.0, 5585.0, 5315.0, 5297.0, 5496.0, 5710.0, 5413.0, 5464.0, 5639.0, 5658.0, 5431.0, 5352.0, 5449.0, 5528.0, 5661.0, 5376.0, 5712.0, 5510.0, 5713.0, 5400.0, 5251.0, 5465.0, 5351.0, 5704.0, 5591.0, 5330.0, 5288.0, 5587.0, 5388.0, 5481.0, 5255.0, 5282.0, 5493.0, 5490.0, 5380.0, 5651.0, 5512.0, 5567.0, 5548.0, 5370.0, 5577.0, 5569.0, 5314.0, 5344.0, 5627.0, 5371.0 (number of hits: 16)
21	5570	9	1	333	1	5706.0, 5516.0, 5600.0, 5557.0, 5438.0,

						5355.0, 5542.0, 5414.0, 5672.0, 5452.0, 5537.0, 5720.0, 5254.0, 5427.0, 5527.0, 5547.0, 5702.0, 5472.0, 5446.0, 5255.0, 5285.0, 5431.0, 5356.0, 5544.0, 5565.0, 5692.0, 5310.0, 5375.0, 5368.0, 5346.0, 5566.0, 5476.0, 5503.0, 5701.0, 5612.0, 5683.0, 5471.0, 5412.0, 5608.0, 5259.0, 5485.0, 5705.0, 5717.0, 5586.0, 5587.0, 5684.0, 5428.0, 5574.0, 5667.0, 5410.0, 5491.0, 5370.0, 5316.0, 5279.0, 5554.0, 5715.0, 5333.0, 5538.0, 5327.0, 5713.0, 5397.0, 5363.0, 5441.0, 5351.0, 5339.0, 5324.0, 5451.0, 5301.0, 5500.0, 5521.0, 5524.0, 5634.0, 5543.0, 5315.0, 5461.0, 5353.0, 5282.0, 5400.0, 5367.0, 5641.0, 5335.0, 5403.0, 5448.0, 5401.0, 5323.0, 5423.0, 5371.0, 5318.0, 5415.0, 5426.0, 5252.0, 5508.0, 5640.0, 5344.0, 5594.0, 5321.0, 5265.0, 5718.0, 5558.0, 5504.0 (number of hits: 17)
22	5570	9	1	333	1	5713.0, 5647.0, 5718.0, 5578.0, 5332.0, 5691.0, 5413.0, 5500.0, 5412.0, 5305.0, 5462.0, 5414.0, 5703.0, 5505.0, 5499.0, 5670.0, 5434.0, 5433.0, 5671.0, 5403.0, 5710.0, 5296.0, 5643.0, 5293.0, 5706.0, 5468.0, 5564.0, 5601.0, 5354.0, 5285.0, 5473.0, 5529.0, 5286.0, 5362.0, 5503.0, 5306.0, 5494.0, 5461.0, 5274.0, 5592.0, 5543.0, 5268.0, 5346.0, 5548.0, 5331.0, 5370.0, 5438.0, 5353.0, 5676.0, 5490.0, 5377.0, 5634.0, 5522.0, 5405.0, 5381.0, 5449.0, 5660.0, 5723.0, 5659.0, 5304.0, 5593.0, 5673.0, 5519.0, 5263.0, 5661.0, 5498.0, 5379.0, 5642.0, 5573.0, 5450.0, 5645.0, 5352.0, 5415.0, 5629.0, 5297.0, 5669.0, 5698.0, 5278.0, 5597.0, 5421.0, 5330.0, 5635.0, 5624.0, 5380.0, 5523.0, 5487.0, 5279.0, 5393.0, 5702.0, 5512.0, 5312.0, 5714.0, 5533.0, 5481.0, 5607.0, 5432.0, 5308.0, 5566.0, 5458.0, 5540.0 (number of hits: 13)
23	5570	9	1	333	1	5284.0, 5678.0, 5650.0, 5377.0, 5554.0, 5452.0, 5488.0, 5500.0, 5330.0, 5476.0, 5421.0, 5351.0, 5583.0, 5539.0, 5375.0, 5373.0, 5309.0, 5383.0, 5352.0, 5296.0, 5593.0, 5318.0, 5698.0, 5392.0, 5497.0, 5519.0, 5620.0, 5687.0, 5279.0, 5348.0, 5604.0, 5507.0, 5361.0, 5319.0, 5603.0, 5278.0, 5653.0, 5520.0, 5571.0, 5506.0, 5493.0, 5573.0, 5693.0, 5324.0, 5305.0, 5285.0, 5409.0, 5526.0, 5618.0, 5533.0, 5415.0, 5445.0, 5294.0, 5659.0, 5611.0, 5709.0, 5619.0, 5394.0, 5286.0, 5402.0, 5713.0, 5308.0, 5505.0, 5523.0, 5349.0, 5326.0, 5502.0, 5642.0, 5509.0, 5689.0, 5253.0, 5468.0, 5665.0, 5543.0, 5399.0, 5274.0, 5708.0, 5568.0, 5462.0, 5355.0, 5281.0, 5624.0, 5546.0, 5387.0, 5711.0, 5358.0, 5522.0, 5578.0, 5594.0, 5498.0, 5446.0, 5466.0, 5569.0, 5518.0, 5384.0, 5588.0, 5508.0, 5499.0, 5337.0, 5307.0

						(number of hits: 16)
24	5570	9	1	333	1	5724.0, 5649.0, 5262.0, 5504.0, 5709.0, 5278.0, 5461.0, 5330.0, 5620.0, 5281.0, 5321.0, 5491.0, 5495.0, 5496.0, 5629.0, 5347.0, 5637.0, 5439.0, 5373.0, 5484.0, 5682.0, 5271.0, 5344.0, 5506.0, 5282.0, 5585.0, 5322.0, 5374.0, 5273.0, 5357.0, 5583.0, 5279.0, 5552.0, 5394.0, 5441.0, 5500.0, 5266.0, 5520.0, 5452.0, 5305.0, 5557.0, 5337.0, 5561.0, 5332.0, 5482.0, 5325.0, 5674.0, 5683.0, 5376.0, 5287.0, 5646.0, 5370.0, 5654.0, 5593.0, 5547.0, 5624.0, 5519.0, 5606.0, 5350.0, 5405.0, 5260.0, 5555.0, 5419.0, 5277.0, 5392.0, 5635.0, 5607.0, 5615.0, 5401.0, 5363.0, 5324.0, 5486.0, 5257.0, 5483.0, 5605.0, 5717.0, 5438.0, 5481.0, 5381.0, 5564.0, 5678.0, 5288.0, 5269.0, 5587.0, 5539.0, 5498.0, 5563.0, 5560.0, 5589.0, 5535.0, 5499.0, 5379.0, 5515.0, 5256.0, 5598.0, 5291.0, 5692.0, 5479.0, 5509.0, 5548.0
						(number of hits: 20)
25	5570	9	1	333	1	5665.0, 5539.0, 5366.0, 5533.0, 5275.0, 5287.0, 5708.0, 5698.0, 5288.0, 5601.0, 5495.0, 5592.0, 5607.0, 5292.0, 5455.0, 5367.0, 5557.0, 5376.0, 5391.0, 5341.0, 5677.0, 5315.0, 5560.0, 5703.0, 5714.0, 5429.0, 5382.0, 5290.0, 5600.0, 5642.0, 5291.0, 5253.0, 5650.0, 5655.0, 5531.0, 5571.0, 5362.0, 5374.0, 5555.0, 5354.0, 5375.0, 5574.0, 5338.0, 5488.0, 5346.0, 5724.0, 5602.0, 5387.0, 5320.0, 5524.0, 5709.0, 5715.0, 5276.0, 5389.0, 5705.0, 5711.0, 5363.0, 5579.0, 5327.0, 5404.0, 5419.0, 5348.0, 5473.0, 5479.0, 5664.0, 5282.0, 5459.0, 5695.0, 5514.0, 5628.0, 5418.0, 5434.0, 5699.0, 5643.0, 5633.0, 5301.0, 5515.0, 5311.0, 5349.0, 5645.0, 5489.0, 5297.0, 5449.0, 5614.0, 5312.0, 5304.0, 5721.0, 5302.0, 5569.0, 5461.0, 5586.0, 5588.0, 5450.0, 5644.0, 5637.0, 5536.0, 5578.0, 5409.0, 5439.0, 5526.0
						(number of hits: 19)
26	5570	9	1	333	1	5431.0, 5428.0, 5321.0, 5253.0, 5596.0, 5385.0, 5395.0, 5269.0, 5309.0, 5343.0, 5452.0, 5498.0, 5695.0, 5665.0, 5405.0, 5311.0, 5409.0, 5613.0, 5609.0, 5399.0, 5365.0, 5281.0, 5555.0, 5346.0, 5300.0, 5429.0, 5581.0, 5335.0, 5659.0, 5481.0, 5694.0, 5717.0, 5254.0, 5682.0, 5590.0, 5573.0, 5403.0, 5654.0, 5374.0, 5313.0, 5563.0, 5260.0, 5279.0, 5250.0, 5512.0, 5710.0, 5657.0, 5396.0, 5471.0, 5679.0, 5317.0, 5611.0, 5668.0, 5307.0, 5326.0, 5367.0, 5519.0, 5375.0, 5494.0, 5482.0, 5370.0, 5456.0, 5536.0, 5719.0, 5552.0, 5400.0, 5467.0, 5524.0, 5318.0, 5716.0, 5473.0, 5617.0, 5635.0, 5334.0, 5336.0, 5623.0, 5676.0, 5608.0, 5411.0, 5463.0, 5277.0, 5562.0, 5466.0, 5568.0, 5691.0, 5474.0, 5387.0, 5388.0, 5257.0, 5656.0

						5549.0, 5651.0, 5598.0, 5322.0, 5655.0, 5666.0, 5477.0, 5701.0, 5286.0, 5479.0 (number of hits: 14)
27	5570	9	1	333	1	5559.0, 5475.0, 5339.0, 5303.0, 5656.0, 5601.0, 5708.0, 5355.0, 5260.0, 5333.0, 5424.0, 5455.0, 5323.0, 5586.0, 5359.0, 5448.0, 5306.0, 5371.0, 5691.0, 5716.0, 5456.0, 5320.0, 5272.0, 5434.0, 5545.0, 5663.0, 5443.0, 5595.0, 5629.0, 5459.0, 5702.0, 5262.0, 5414.0, 5528.0, 5292.0, 5486.0, 5567.0, 5701.0, 5427.0, 5529.0, 5308.0, 5296.0, 5345.0, 5366.0, 5479.0, 5671.0, 5484.0, 5369.0, 5668.0, 5679.0, 5672.0, 5546.0, 5413.0, 5465.0, 5317.0, 5438.0, 5539.0, 5420.0, 5286.0, 5592.0, 5611.0, 5673.0, 5266.0, 5632.0, 5423.0, 5279.0, 5580.0, 5609.0, 5444.0, 5719.0, 5487.0, 5521.0, 5309.0, 5258.0, 5507.0, 5599.0, 5324.0, 5662.0, 5576.0, 5380.0, 5280.0, 5516.0, 5526.0, 5552.0, 5276.0, 5357.0, 5481.0, 5363.0, 5556.0, 5689.0, 5347.0, 5697.0, 5707.0, 5342.0, 5297.0, 5658.0, 5477.0, 5274.0, 5356.0, 5548.0 (number of hits: 16)
28	5570	9	1	333	1	5700.0, 5449.0, 5689.0, 5717.0, 5624.0, 5428.0, 5546.0, 5651.0, 5288.0, 5366.0, 5550.0, 5401.0, 5278.0, 5619.0, 5463.0, 5425.0, 5330.0, 5410.0, 5658.0, 5532.0, 5336.0, 5453.0, 5295.0, 5472.0, 5609.0, 5654.0, 5650.0, 5564.0, 5617.0, 5352.0, 5256.0, 5698.0, 5507.0, 5630.0, 5322.0, 5439.0, 5477.0, 5337.0, 5659.0, 5386.0, 5703.0, 5397.0, 5403.0, 5424.0, 5263.0, 5656.0, 5563.0, 5414.0, 5677.0, 5325.0, 5681.0, 5427.0, 5422.0, 5536.0, 5294.0, 5342.0, 5520.0, 5601.0, 5641.0, 5682.0, 5530.0, 5473.0, 5575.0, 5252.0, 5484.0, 5305.0, 5285.0, 5344.0, 5664.0, 5478.0, 5628.0, 5485.0, 5600.0, 5409.0, 5513.0, 5257.0, 5715.0, 5350.0, 5632.0, 5481.0, 5307.0, 5604.0, 5464.0, 5684.0, 5720.0, 5709.0, 5343.0, 5286.0, 5360.0, 5494.0, 5315.0, 5690.0, 5714.0, 5657.0, 5565.0, 5613.0, 5518.0, 5398.0, 5488.0, 5299.0 (number of hits: 13)
29	5570	9	1	333	1	5336.0, 5706.0, 5314.0, 5546.0, 5416.0, 5616.0, 5359.0, 5547.0, 5570.0, 5251.0, 5512.0, 5590.0, 5638.0, 5477.0, 5685.0, 5295.0, 5594.0, 5655.0, 5411.0, 5709.0, 5447.0, 5313.0, 5674.0, 5288.0, 5462.0, 5442.0, 5720.0, 5699.0, 5446.0, 5440.0, 5305.0, 5433.0, 5369.0, 5396.0, 5619.0, 5534.0, 5464.0, 5482.0, 5696.0, 5343.0, 5540.0, 5267.0, 5561.0, 5680.0, 5271.0, 5339.0, 5660.0, 5555.0, 5658.0, 5516.0, 5259.0, 5666.0, 5473.0, 5430.0, 5623.0, 5493.0, 5487.0, 5595.0, 5631.0, 5428.0, 5659.0, 5383.0, 5439.0, 5598.0, 5684.0, 5648.0, 5366.0, 5585.0, 5486.0, 5413.0, 5528.0, 5678.0, 5532.0, 5332.0, 5312.0, 5320.0, 5327.0, 5549.0, 5665.0, 5553.0,

						5340.0, 5455.0, 5544.0, 5647.0, 5545.0, 5614.0, 5354.0, 5517.0, 5611.0, 5361.0, 5407.0, 5627.0, 5374.0, 5552.0, 5539.0, 5525.0, 5715.0, 5358.0, 5321.0, 5256.0 (number of hits: 19)
30	5570	9	1	333	1	5271.0, 5546.0, 5395.0, 5694.0, 5355.0, 5321.0, 5518.0, 5393.0, 5427.0, 5583.0, 5491.0, 5476.0, 5639.0, 5658.0, 5588.0, 5364.0, 5358.0, 5711.0, 5303.0, 5398.0, 5720.0, 5716.0, 5532.0, 5347.0, 5603.0, 5683.0, 5708.0, 5292.0, 5700.0, 5515.0, 5350.0, 5330.0, 5259.0, 5538.0, 5712.0, 5481.0, 5262.0, 5372.0, 5440.0, 5413.0, 5530.0, 5619.0, 5670.0, 5552.0, 5415.0, 5678.0, 5610.0, 5641.0, 5676.0, 5345.0, 5580.0, 5570.0, 5268.0, 5562.0, 5643.0, 5549.0, 5296.0, 5508.0, 5472.0, 5500.0, 5366.0, 5359.0, 5477.0, 5531.0, 5343.0, 5286.0, 5283.0, 5557.0, 5626.0, 5587.0, 5655.0, 5300.0, 5254.0, 5361.0, 5692.0, 5287.0, 5353.0, 5579.0, 5512.0, 5674.0, 5460.0, 5369.0, 5375.0, 5323.0, 5682.0, 5291.0, 5595.0, 5251.0, 5422.0, 5349.0, 5367.0, 5492.0, 5547.0, 5255.0, 5722.0, 5309.0, 5597.0, 5467.0, 5644.0, 5290.0 (number of hits: 19)

A.4 160 MHz Bandwidth @ 5570 MHz

Table-1A/1B Radar Type 1A/1B Statistical Performance

Trial #	Fc (MHz)	Pulse/Burst	Pulse Width (μS)	PRI (μs)	Detection (1:yes; 0:no)
1	5490	67	1	798	1
2	5490	74	1	718	1
3	5490	92	1	578	1
4	5490	70	1	758	1
5	5490	72	1	738	1
6	5570	95	1	558	1
7	5570	68	1	778	1
8	5570	83	1	638	1
9	5570	99	1	538	1
10	5570	63	1	838	1
11	5650	81	1	658	1
12	5650	58	1	918	1
13	5650	89	1	598	1
14	5650	78	1	678	1
15	5650	65	1	818	1
16	5490	29	1	1868	1
17	5490	87	1	611	1
18	5490	21	1	2524	1
19	5490	38	1	1420	1
20	5490	43	1	1228	1
21	5570	20	1	2697	1
22	5570	18	1	2963	1
23	5570	77	1	693	1
24	5570	21	1	2632	1
25	5570	29	1	1833	1
26	5650	23	1	2375	1
27	5650	19	1	2917	1
28	5650	34	1	1563	1
29	5650	19	1	2796	1
30	5650	28	1	1950	1
Detection Percentage: 100 % (>60%)					

Table-2 Radar Type 2 Statistical Performance

Trial #	Fc (MHz)	Pulse/Burst	Pulse Width (μ S)	PRI (μ s)	Detection (1:yes; 0:no)
1	5490	23	2.6	214	1
2	5490	24	2.1	215	1
3	5490	29	4.2	224	1
4	5490	26	4.8	199	1
5	5490	29	1.2	165	1
6	5490	25	1.6	196	1
7	5490	25	3.4	212	1
8	5490	26	3.8	211	1
9	5490	23	1.8	220	1
10	5490	26	3.7	169	1
11	5570	29	2.3	203	1
12	5570	24	2.7	181	1
13	5570	23	4.1	154	1
14	5570	26	1.9	201	1
15	5570	23	4.2	207	1
16	5570	28	2.7	196	1
17	5570	25	1.8	194	1
18	5570	25	4.5	190	1
19	5570	27	4.4	188	1
20	5570	27	3.8	153	1
21	5650	29	4.7	167	1
22	5650	25	4.1	157	1
23	5650	28	2.3	207	1
24	5650	28	1.9	225	1
25	5650	23	3.2	209	1
26	5650	23	3.2	156	1
27	5650	27	4	160	1
28	5650	24	4.7	219	1
29	5650	23	2.2	157	1
30	5650	26	3	167	1
Detection Percentage: 100 % (>60%)					

Table-3 Radar Type 3 Statistical Performance

Trial #	Fc (MHz)	Pulse/Burst	Pulse Width (μS)	PRI (μs)	Detection (1:yes; 0:no)
1	5490	16	7.6	489	1
2	5490	16	6.6	217	1
3	5490	17	9.1	396	0
4	5490	16	8	426	1
5	5490	18	7.4	349	1
6	5490	16	9.5	434	1
7	5490	18	7.2	249	1
8	5490	17	9.8	378	0
9	5490	18	9.3	342	0
10	5490	18	7.7	485	1
11	5570	16	6.6	435	1
12	5570	18	6	253	1
13	5570	18	9.2	381	0
14	5570	17	6.5	302	1
15	5570	16	7	370	1
16	5570	18	9.5	356	0
17	5570	16	8.5	405	1
18	5570	16	7	441	1
19	5570	16	6.7	384	1
20	5570	16	6.4	320	1
21	5650	18	6.3	267	1
22	5650	18	6.1	363	1
23	5650	17	6	493	1
24	5650	18	7.7	363	1
25	5650	16	7	242	1
26	5650	17	8.3	413	1
27	5650	18	6.8	249	1
28	5650	17	8.4	443	1
29	5650	18	8.6	373	1
30	5650	16	8.6	447	1
Detection Percentage: 83.33 % (>60%)					

Table-4 Radar Type 4 Statistical Performance

Trial #	Fc (MHz)	Pulse/Burst	Pulse Width (μS)	PRI (μs)	Detection (1:yes; 0:no)
1	5490	12	15.7	205	1
2	5490	13	18.2	356	1
3	5490	16	17.9	463	1
4	5490	15	13.6	223	1
5	5490	12	12	310	1
6	5490	14	15.7	225	1
7	5490	14	12.1	352	1
8	5490	13	13.5	394	1
9	5490	15	17.2	312	1
10	5490	13	13.8	374	1
11	5570	15	17.3	251	1
12	5570	13	14.7	443	1
13	5570	16	19.6	259	1
14	5570	12	19.4	258	1
15	5570	15	14.3	370	0
16	5570	14	12.6	382	0
17	5570	15	16.5	394	1
18	5570	13	17.6	290	1
19	5570	15	12.9	368	1
20	5570	15	13.7	233	1
21	5650	14	19.8	204	1
22	5650	13	17.6	466	0
23	5650	14	16.5	251	1
24	5650	12	11.1	306	0
25	5650	13	11.8	322	0
26	5650	14	13.9	292	0
27	5650	13	14.4	441	1
28	5650	14	15.4	256	1
29	5650	13	12.7	474	1
30	5650	14	15.8	300	1
Detection Percentage: 80 % (>60%)					

Table-5 Radar Type 5 Statistical Performance

Trial #	Fc (MHz)	Detection (1:yes; 0:no)
1	5570.0	1
2	5570.0	1
3	5570.0	1
4	5570.0	1
5	5570.0	1
6	5570.0	1
7	5570.0	1
8	5570.0	1
9	5570.0	1
10	5570.0	1
11	5494.4	1
12	5495.6	1
13	5495.6	1
14	548.0	1
15	5495.2	1
16	5493.2	1
17	5496.4	1
18	5494.4	1
19	5496.0	1
20	5494.0	1
21	5643.6	1
22	5642.4	1
23	5644.4	1
24	5646.4	1
25	5642.8	1
26	5645.2	1
27	5645.6	1
28	5642.0	1
29	5644.8	1
30	5643.6	1
Detection Percentage: 100 % (>80%)		

Bin5 Statistics 1

Trial #	Pulse	Chirp (MHz)	Pulse Width (µS)	Pulse 1-2 spacing (uS)	Pulse 2-3 spacing (uS)	Pulse Start(S)	Detection (1:yes; 0:no)
0	3	15	75.4	1847	1973	1.120544	1
1	3	15	53.6	1965	1243	1.742379	
2	3	15	94.6	1237	1347	3.001051	
3	2	15	81.1	1848		4.374231	
4	2	15	74.3	1814		5.437962	
5	1	15	94.4			7.940677	
6	2	15	51.4	1184		8.469145	
7	2	15	84.1	1952		9.90014	
8	1	15	61.8			11.312824	

Bin5 Statistics 2

Trial #	Pulse	Chirp (MHz)	Pulse Width (µS)	Pulse 1-2 spacing (uS)	Pulse 2-3 spacing (uS)	Pulse Start(S)	Detection (1:yes; 0:no)
0	1	16	61.7			0.375778	1
1	1	16	88			1.782779	
2	1	16	74.8			3.0205	
3	1	16	74.4			4.252663	
4	2	16	51.1	1313		4.896372	
5	2	16	83	1119		6.090749	
6	3	16	60.2	1538	1170	7.288188	
7	1	16	65.3			8.51675	
8	1	16	89.3			8.878454	
9	2	16	61.9	1101		10.583645	
10	2	16	75.9	1685		11.501706	

Bin5 Statistics 3

Trial #	Pulse	Chirp (MHz)	Pulse Width (µS)	Pulse 1-2 spacing (uS)	Pulse 2-3 spacing (uS)	Pulse Start(S)	Detection (1:yes; 0:no)
0	2	15	64.4	1171		1.076627	1
1	1	15	52.4			1.97079	
2	3	15	92.1	1184	1069	3.051559	
3	2	15	68.5	1463		3.720479	
4	3	15	55.6	1216	1068	5.15065	
5	2	15	86.7	1030		6.078512	
6	3	15	73.7	1217	2000	6.73237	
7	3	15	75.3	1133	1210	7.951273	
8	3	15	97.8	1477	1154	9.757743	
9	1	15	54.4			9.999126	
10	2	15	50.9	1283		11.60717	

Bin5 Statistics 4

Trial #	Pulse	Chirp (MHz)	Pulse Width (µS)	Pulse 1-2 spacing (uS)	Pulse 2-3 spacing (uS)	Pulse Start(S)	Detection (1:yes; 0:no)
0	2	6	78.8	1029		0.009124	1
1	2	6	74.3	1996		1.240655	
2	3	6	50.4	1150	1452	2.280576	
3	1	6	96.5			3.022799	
4	2	6	81.1	1160		3.840278	
5	2	6	91	1641		5.292129	
6	2	6	58	1135		6.301764	
7	2	6	76	1361		6.562273	
8	1	6	65.4			7.853696	
9	3	6	57.5	1127	1964	8.340678	
10	2	6	93.1	1764		9.933043	
11	2	6	72.7	1007		11.026318	
12	1	6	99.5			11.491333	

Bin5 Statistics 5

Trial #	Pulse	Chirp (MHz)	Pulse Width (µS)	Pulse 1-2 spacing (uS)	Pulse 2-3 spacing (uS)	Pulse Start(S)	Detection (1:yes; 0:no)
0	3	15	54.4	1112	1322	0.039287	1
1	2	15	80.3	1534		0.631928	
2	1	15	54.3			1.762764	
3	3	15	59.3	1017	1678	2.334839	
4	3	15	58.9	1437	1437	2.517011	
5	2	15	66.9	1793		3.562423	
6	2	15	68.2	1516		3.808148	
7	2	15	64.5	1627		4.335705	
8	2	15	68.3	1809		5.202233	
9	2	15	54	1469		5.595587	
10	2	15	56.7	1740		6.075269	
11	3	15	70.2	1715	1332	6.808305	
12	3	15	51.3	1213	1676	7.743099	
13	2	15	75.2	1988		8.347368	
14	2	15	54	1980		8.593389	
15	3	15	62.5	1123	1401	9.214863	
16	2	15	85.2	1320		9.721416	
17	2	15	81.5	1957		10.20879	
18	3	15	54.6	1044	1152	11.318173	
19	1	15	92.3			11.404409	

Bin5 Statistics 6

Trial #	Pulse	Chirp (MHz)	Pulse Width (µS)	Pulse 1-2 spacing (uS)	Pulse 2-3 spacing (uS)	Pulse Start(S)	Detection (1:yes; 0:no)
0	3	8	84.5	1733	1784	0.006891	1
1	1	8	89.5			0.97889	
2	2	8	74.3	1962		1.884639	
3	2	8	95.8	1903		2.25627	
4	2	8	88.6	1057		3.232711	
5	3	8	92.8	1526	1418	3.348891	
6	1	8	67.7			4.139279	
7	2	8	52.6	1692		5.049374	
8	2	8	96.3	1842		5.978348	
9	2	8	57.7	1563		6.576652	
10	3	8	57.6	1700	1943	7.268644	
11	3	8	83.4	1643	1756	7.832069	
12	1	8	98.9			8.184651	
13	3	8	62.3	1830	1692	9.152767	
14	3	8	54.8	1701	1584	9.362711	
15	1	8	95.8			10.157618	
16	3	8	92.2	1882	1472	10.677711	
17	3	8	64.1	1930	1321	11.653987	

Bin5 Statistics 7

Trial #	Pulse	Chirp (MHz)	Pulse Width (µS)	Pulse 1-2 spacing (uS)	Pulse 2-3 spacing (uS)	Pulse Start(S)	Detection (1:yes; 0:no)
0	3	7	82.4	1239	1928	0.214644	1
1	3	7	91.3	1519	1455	1.303306	
2	3	7	58.3	1103	1180	1.593606	
3	3	7	91.4	1744	1725	2.408178	
4	2	7	79.8	1062		3.291707	
5	2	7	88	1233		4.268922	
6	1	7	51.2			5.149341	
7	1	7	65.1			5.424538	
8	2	7	75.8	1763		6.306882	
9	1	7	52.5			7.045079	
10	3	7	87.1	1939	1595	8.068779	
11	2	7	65	1499		8.544399	
12	2	7	53	1961		9.743853	
13	2	7	86.8	1594		9.960023	
14	3	7	57.9	1791	1483	10.837513	
15	3	7	55.7	1491	1027	11.392903	

Bin5 Statistics 8

Trial #	Pulse	Chirp (MHz)	Pulse Width (μS)	Pulse 1-2 spacing (uS)	Pulse 2-3 spacing (uS)	Pulse Start(S)	Detection (1:yes; 0:no)
0	2	9	98.5	1745		0.555594	1
1	3	9	59	1832	1597	1.502569	
2	1	9	73.5			2.223997	
3	3	9	60.8	1407	1676	3.395343	
4	2	9	75.8	1710		4.308287	
5	2	9	96	1175		4.686299	
6	1	9	57.4			5.988469	
7	1	9	95.7			7.130426	
8	1	9	53.1			8.050717	
9	3	9	81	1943	1571	8.970604	
10	1	9	69.1			9.657087	
11	1	9	58.3			10.262679	
12	2	9	58.6	1723		11.496871	

Bin5 Statistics 9

Trial #	Pulse	Chirp (MHz)	Pulse Width (μS)	Pulse 1-2 spacing (uS)	Pulse 2-3 spacing (uS)	Pulse Start(S)	Detection (1:yes; 0:no)
0	2	14	75.2	1113		0.794795	1
1	3	14	53.6	1902	1151	1.21296	
2	1	14	74.4			1.914342	
3	3	14	83.2	1429	1987	3.303922	
4	3	14	76.7	1475	1571	4.466512	
5	1	14	97.7			4.812343	
6	3	14	78.5	1650	1623	5.590543	
7	3	14	79.3	1028	1621	6.999606	
8	1	14	88			7.536308	
9	2	14	68.1	1650		8.351253	
10	3	14	94.4	1209	1600	10.114152	
11	3	14	61.3	1586	1207	10.354419	
12	1	14	96.5			11.548259	

Bin5 Statistics 10

Trial #	Pulse	Chirp (MHz)	Pulse Width (µS)	Pulse 1-2 spacing (uS)	Pulse 2-3 spacing (uS)	Pulse Start(S)	Detection (1:yes; 0:no)
0	1	9	83.6			0.015475	1
1	2	9	77.5	1027		1.077895	
2	1	9	55.7			1.965105	
3	3	9	56.6	1954	1430	2.603247	
4	3	9	74.3	1013	1566	3.829281	
5	1	9	82			5.012808	
6	2	9	73.3	1905		5.345686	
7	3	9	78.8	1080	1540	6.554904	
8	1	9	62			7.046412	
9	2	9	95	1209		7.926026	
10	3	9	69.8	1783	1810	8.77008	
11	2	9	58.8	1979		10.000845	
12	2	9	77.9	1038		11.067859	
13	2	9	64.4	1342		11.203276	

Bin5 Statistics 11

Trial #	Pulse	Chirp (MHz)	Pulse Width (µS)	Pulse 1-2 spacing (uS)	Pulse 2-3 spacing (uS)	Pulse Start(S)	Detection (1:yes; 0:no)
0	3	11	92.2	1435	1252	0.189943	1
1	1	11	57.6			1.21012	
2	2	11	50.3	1191		2.593961	
3	2	11	72.5	1777		3.221514	
4	2	11	79.3	1753		4.512637	
5	3	11	66.9	1943	1147	5.183474	
6	1	11	73.5			6.071081	
7	2	11	90.1	1324		7.239692	
8	1	11	92.4			8.895866	
9	3	11	56	1139	1294	9.106958	
10	2	11	64.5	1784		10.13377	
11	2	11	85.9	1824		11.541407	

Bin5 Statistics 12

Trial #	Pulse	Chirp (MHz)	Pulse Width (µS)	Pulse 1-2 spacing (uS)	Pulse 2-3 spacing (uS)	Pulse Start(S)	Detection (1:yes; 0:no)
0	1	14	59.5			0.608683	1
1	2	14	63.9	1077		1.350329	
2	2	14	59.1	1618		2.320422	
3	2	14	77.2	1308		2.991599	
4	1	14	99.3			3.763114	
5	3	14	62.7	1295	1624	4.945511	
6	3	14	84.2	1431	1400	6.227897	
7	3	14	96.9	1239	1510	6.928089	
8	2	14	95.2	1922		7.798408	
9	3	14	65.1	1333	1199	8.564056	
10	1	14	77.1			9.253199	
11	2	14	73.8	1865		11.004062	
12	1	14	73.5			11.496433	

Bin5 Statistics 13

Trial #	Pulse	Chirp (MHz)	Pulse Width (µS)	Pulse 1-2 spacing (uS)	Pulse 2-3 spacing (uS)	Pulse Start(S)	Detection (1:yes; 0:no)
0	2	14	61.7	1976		0.668891	1
1	3	14	88.4	1433	1543	0.81218	
2	1	14	89.8			1.690271	
3	1	14	55.8			2.738627	
4	2	14	88.8	1759		3.404471	
5	3	14	86.6	1839	1349	3.662026	
6	1	14	79			4.902943	
7	2	14	86.2	1822		5.251865	
8	2	14	79.8	1338		6.278027	
9	3	14	58.5	1589	1377	6.874778	
10	2	14	58.7	1497		7.265909	
11	1	14	76.1			8.065655	
12	3	14	88.2	1375	1428	8.66824	
13	2	14	79.7	1286		9.46767	
14	2	14	82	1207		10.499431	
15	3	14	99.1	1953	1778	11.037357	
16	3	14	85	1279	1376	11.6365	

Bin5 Statistics 14

Trial #	Pulse	Chirp (MHz)	Pulse Width (μS)	Pulse 1-2 spacing (uS)	Pulse 2-3 spacing (uS)	Pulse Start(S)	Detection (1:yes; 0:no)
0	1	20	99.4			0.920335	1
1	3	20	68.1	1356	1030	1.392765	
2	1	20	61.6			2.458116	
3	1	20	95.9			4.062341	
4	2	20	89.7	1028		5.434101	
5	2	20	60.9	1560		7.122391	
6	2	20	56.4	1826		7.914469	
7	3	20	75.9	1196	1575	9.051916	
8	1	20	75.5			10.737682	
9	2	20	55.4	1057		10.853807	

Bin5 Statistics 15

Trial #	Pulse	Chirp (MHz)	Pulse Width (μS)	Pulse 1-2 spacing (uS)	Pulse 2-3 spacing (uS)	Pulse Start(S)	Detection (1:yes; 0:no)
0	1	13	78			0.555687	1
1	3	13	56.8	1508	1051	1.246579	
2	1	13	86.6			2.176203	
3	3	13	90.1	1701	1486	2.903667	
4	1	13	59.4			3.455176	
5	2	13	89.8	1404		4.400786	
6	2	13	77.2	1694		4.828952	
7	2	13	68	1996		5.791269	
8	2	13	65.1	1576		6.657889	
9	3	13	72.8	1143	1990	7.43222	
10	2	13	64.5	1917		7.928153	
11	3	13	52.5	1878	1261	8.714586	
12	2	13	60.7	1457		9.224321	
13	2	13	81.8	1222		10.188086	
14	2	13	85.9	1798		10.649213	
15	1	13	84.3			11.414972	

Bin5 Statistics 16

Trial #	Pulse	Chirp (MHz)	Pulse Width (µS)	Pulse 1-2 spacing (uS)	Pulse 2-3 spacing (uS)	Pulse Start(S)	Detection (1:yes; 0:no)
0	2	8	95.2	1841		0.239128	1
1	2	8	56.9	1060		0.688907	
2	1	8	77.4			1.687485	
3	2	8	90.5	1814		2.196654	
4	3	8	99.9	1866	1768	2.780988	
5	2	8	92.3	1037		3.241492	
6	3	8	52.1	1716	1161	3.630865	
7	3	8	72.7	1847	1228	4.646225	
8	2	8	89.7	1265		4.807183	
9	2	8	55.6	1102		5.435026	
10	1	8	51.2			6.11961	
11	1	8	74.2			6.885558	
12	2	8	70.9	1097		7.283689	
13	2	8	79.7	1886		8.079887	
14	2	8	55.2	1109		8.72593	
15	3	8	70.4	1981	1070	9.209995	
16	2	8	60.1	1945		9.824759	
17	2	8	87.9	1661		10.595387	
18	2	8	60.4	1254		11.269896	
19	3	8	85	1586	1784	11.982965	

Bin5 Statistics 17

Trial #	Pulse	Chirp (MHz)	Pulse Width (µS)	Pulse 1-2 spacing (uS)	Pulse 2-3 spacing (uS)	Pulse Start(S)	Detection (1:yes; 0:no)
0	3	16	96.4	1909	1144	0.768453	1
1	3	16	54.9	1958	1530	1.068895	
2	3	16	74.3	1343	1397	2.101533	
3	1	16	70.6			2.784155	
4	2	16	79.3	1494		3.803079	
5	2	16	78.7	1047		4.614599	
6	1	16	57.9			4.951933	
7	1	16	52.5			5.900461	
8	2	16	71.5	1725		6.929289	
9	1	16	67.3			7.64622	
10	2	16	69.7	1224		8.742314	
11	2	16	70.6	1829		8.898416	
12	2	16	91.8	1089		10.28754	
13	2	16	64	1206		11.126317	
14	1	16	98.5			11.568782	

Bin5 Statistics 18

Trial #	Pulse	Chirp (MHz)	Pulse Width (µS)	Pulse 1-2 spacing (uS)	Pulse 2-3 spacing (uS)	Pulse Start(S)	Detection (1:yes; 0:no)
0	3	11	71.4	1997	1775	0.790008	1
1	1	11	56.2			1.067441	
2	2	11	55.1	1017		2.293894	
3	3	11	78.9	1010	1425	3.503446	
4	1	11	76			3.804999	
5	2	11	53.6	1873		4.789267	
6	1	11	87.5			5.802993	
7	2	11	91.4	1390		6.777856	
8	1	11	78			7.560718	
9	3	11	67.3	1994	1284	9.049285	
10	2	11	62.6	1391		9.398402	
11	3	11	87.2	1461	1815	10.583967	
12	2	11	64.9	1249		11.861439	

Bin5 Statistics 19

Trial #	Pulse	Chirp (MHz)	Pulse Width (µS)	Pulse 1-2 spacing (uS)	Pulse 2-3 spacing (uS)	Pulse Start(S)	Detection (1:yes; 0:no)
0	2	15	83.4	1678		0.268496	1
1	2	15	81.9	1074		1.107128	
2	3	15	50.9	1576	1895	1.789461	
3	1	15	79			2.550537	
4	2	15	99.2	1837		2.92726	
5	2	15	96.3	1162		3.3708	
6	2	15	78.3	1617		4.498753	
7	1	15	83.6			5.30508	
8	2	15	92.5	1428		5.616579	
9	2	15	66.7	1053		6.149904	
10	2	15	69.8	1760		7.275701	
11	1	15	51			7.403701	
12	3	15	78	1316	1996	8.298994	
13	3	15	65.2	1954	1275	8.922642	
14	3	15	68.4	1323	1495	9.722345	
15	2	15	96.2	1077		10.381844	
16	2	15	82.5	1722		11.091766	
17	2	15	94.4	1429		11.701527	

Bin5 Statistics 20

Trial #	Pulse	Chirp (MHz)	Pulse Width (µS)	Pulse 1-2 spacing (µS)	Pulse 2-3 spacing (µS)	Pulse Start(S)	Detection (1:yes; 0:no)
0	3	10	89.8	1472	1857	0.171528	1
1	3	10	92.1	1651	1494	0.744087	
2	3	10	97	1974	1899	1.856924	
3	1	10	69.9			2.314669	
4	2	10	70.8	1224		3.002305	
5	2	10	74.2	1194		3.208986	
6	1	10	88.3			3.864433	
7	2	10	53.3	1448		4.832158	
8	3	10	76	1507	1238	5.351823	
9	3	10	67.1	1163	1617	6.209567	
10	2	10	64.2	1625		6.365558	
11	2	10	77.8	1699		7.313018	
12	3	10	53.6	1328	1006	7.915907	
13	3	10	55.8	1752	1850	8.380543	
14	3	10	50.9	1456	1019	8.951413	
15	2	10	76.4	1702		9.612423	
16	3	10	99.4	1924	1241	10.402194	
17	2	10	90.3	1714		11.350802	
18	2	10	53.4	1647		11.599239	

Bin5 Statistics 21

Trial #	Pulse	Chirp (MHz)	Pulse Width (µS)	Pulse 1-2 spacing (uS)	Pulse 2-3 spacing (uS)	Pulse Start(S)	Detection (1:yes; 0:no)
0	1	16	99.5			0.54387	1
1	2	16	79.5	1282		0.983168	
2	3	16	75.4	1433	1977	1.618123	
3	2	16	51.5	1812		2.504149	
4	2	16	68.3	1953		2.736534	
5	2	16	83.3	1827		3.276688	
6	2	16	51.8	1300		4.23125	
7	1	16	53			4.73238	
8	3	16	92	1762	1334	5.576064	
9	1	16	92.5			6.177948	
10	2	16	86	1179		6.855739	
11	1	16	85.3			7.363153	
12	3	16	51.7	1927	1188	7.825948	
13	2	16	89.6	1993		8.361152	
14	1	16	72.3			9.313429	
15	2	16	61.1	1035		9.810283	
16	3	16	79.2	1632	1214	10.467842	
17	3	16	89.9	1816	1155	11.204767	
18	1	16	64.1			11.901405	

Bin5 Statistics 22

Trial #	Pulse	Chirp (MHz)	Pulse Width (µS)	Pulse 1-2 spacing (uS)	Pulse 2-3 spacing (uS)	Pulse Start(S)	Detection (1:yes; 0:no)
0	1	19	56			0.093674	1
1	2	19	51.6	1292		0.941525	
2	1	19	90			2.135911	
3	3	19	54.1	1574	1267	2.815214	
4	2	19	50.5	1086		3.987229	
5	2	19	97.2	1986		5.230059	
6	2	19	58.6	1976		5.812587	
7	1	19	62.1			6.744528	
8	3	19	65.4	1004	1374	7.975272	
9	2	19	74.3	1353		8.497834	
10	2	19	74.4	1956		9.471536	
11	3	19	75.1	1983	1305	10.243894	
12	2	19	92.2	1207		11.72441	

Bin5 Statistics 23

Trial #	Pulse	Chirp (MHz)	Pulse Width (µS)	Pulse 1-2 spacing (µS)	Pulse 2-3 spacing (µS)	Pulse Start(S)	Detection (1:yes; 0:no)
0	2	14	68.5	1133		0.249975	1
1	2	14	67.8	1225		2.014377	
2	2	14	98.6	1003		2.651039	
3	2	14	73	1442		3.926323	
4	2	14	63.2	1803		4.836943	
5	2	14	80.2	1913		6.518384	
6	2	14	62.3	1751		7.116337	
7	3	14	60.7	1759	1336	8.196878	
8	2	14	82	1712		9.375187	
9	2	14	91.1	1868		9.931213	
10	2	14	91.7	1906		11.924035	

Bin5 Statistics 24

Trial #	Pulse	Chirp (MHz)	Pulse Width (µS)	Pulse 1-2 spacing (µS)	Pulse 2-3 spacing (µS)	Pulse Start(S)	Detection (1:yes; 0:no)
0	2	9	71.1	1567		0.409744	1
1	1	9	84.5			1.553854	
2	2	9	89	1596		3.20931	
3	1	9	63.3			3.568747	
4	2	9	79.8	1648		4.892097	
5	3	9	74.5	1560	1715	5.82247	
6	3	9	60.9	1607	1191	7.340714	
7	3	9	99.5	1209	1519	8.638063	
8	1	9	66.6			9.226676	
9	3	9	61.7	1399	1585	10.618831	
10	2	9	83.2	1319		11.542356	

Bin5 Statistics 25

Trial #	Pulse	Chirp (MHz)	Pulse Width (µS)	Pulse 1-2 spacing (uS)	Pulse 2-3 spacing (uS)	Pulse Start(S)	Detection (1:yes; 0:no)
0	1	18	94.8			0.268961	1
1	2	18	91.5	1921		0.761587	
2	1	18	83.3			1.730372	
3	2	18	84.9	1050		1.981106	
4	2	18	89.6	1994		2.884009	
5	3	18	67.3	1810	1587	3.550062	
6	3	18	68.4	1969	1309	4.266936	
7	2	18	55.2	1023		4.912447	
8	1	18	54.5			5.354779	
9	2	18	91.6	1678		5.920024	
10	2	18	84.3	1430		6.780546	
11	1	18	73.7			7.354453	
12	3	18	55	1433	1350	7.852408	
13	1	18	51.9			8.244463	
14	2	18	54.5	1649		9.135501	
15	3	18	50.2	1448	1005	9.789081	
16	2	18	72.4	1731		10.653944	
17	1	18	62.8			10.762784	
18	1	18	61.4			11.761044	

Bin5 Statistics 26

Trial #	Pulse	Chirp (MHz)	Pulse Width (µS)	Pulse 1-2 spacing (uS)	Pulse 2-3 spacing (uS)	Pulse Start(S)	Detection (1:yes; 0:no)
0	3	12	72.3	1157	1623	0.601822	1
1	1	12	54.8			1.992403	
2	2	12	59.7	1601		3.430064	
3	2	12	59.2	1785		4.018056	
4	2	12	50.1	1713		6.249833	
5	1	12	58.4			7.669682	
6	2	12	87.3	1078		8.281792	
7	1	12	83.4			9.979618	
8	3	12	82.8	1379	1692	11.017989	

Bin5 Statistics 27

Trial #	Pulse	Chirp (MHz)	Pulse Width (µS)	Pulse 1-2 spacing (uS)	Pulse 2-3 spacing (uS)	Pulse Start(S)	Detection (1:yes; 0:no)
0	1	11	63.2			0.320251	1
1	1	11	54			1.438741	
2	2	11	96.6	1843		1.749247	
3	2	11	72.3	1881		2.615666	
4	3	11	82.3	1688	1957	3.512974	
5	3	11	83.2	1541	1049	4.875671	
6	3	11	78.1	1351	1022	5.603	
7	2	11	52.6	1936		6.735839	
8	2	11	55.5	1695		7.30886	
9	2	11	86.4	1237		8.206873	
10	2	11	87.7	1548		8.785963	
11	1	11	60.7			9.810818	
12	2	11	72	1762		10.958854	
13	2	11	65.4	1426		11.626014	

Bin5 Statistics 28

Trial #	Pulse	Chirp (MHz)	Pulse Width (µS)	Pulse 1-2 spacing (uS)	Pulse 2-3 spacing (uS)	Pulse Start(S)	Detection (1:yes; 0:no)
0	3	20	87	1340	1829	0.765074	1
1	2	20	70	1086		1.941696	
2	1	20	75.5			2.302691	
3	2	20	94.2	1894		3.40623	
4	2	20	79.7	1882		4.497351	
5	2	20	99.6	1191		5.834959	
6	2	20	96.5	1285		6.855804	
7	2	20	82.7	1308		7.816222	
8	3	20	86.3	1134	1043	8.74807	
9	1	20	91.8			9.708823	
10	1	20	76.5			10.980182	
11	2	20	74.6	1138		11.032936	

Bin5 Statistics 29

Trial #	Pulse	Chirp (MHz)	Pulse Width (µS)	Pulse 1-2 spacing (uS)	Pulse 2-3 spacing (uS)	Pulse Start(S)	Detection (1:yes; 0:no)
0	1	13	72.6			0.352324	1
1	2	13	64.9	1526		1.590329	
2	1	13	54.6			4.440658	
3	2	13	72	1889		5.629501	
4	2	13	98.8	1253		7.423622	
5	2	13	82.6	1879		8.266158	
6	1	13	87.6			10.284242	
7	2	13	59.3	1087		10.50162	

Bin5 Statistics 30

Trial #	Pulse	Chirp (MHz)	Pulse Width (µS)	Pulse 1-2 spacing (uS)	Pulse 2-3 spacing (uS)	Pulse Start(S)	Detection (1:yes; 0:no)
0	2	16	63.1	1284		0.318879	1
1	2	16	90.7	1212		1.419484	
2	2	16	53.9	1541		2.143795	
3	1	16	70.1			2.409501	
4	3	16	83.1	1833	1031	3.385843	
5	1	16	67.7			3.757004	
6	3	16	67.3	1838	1401	4.533836	
7	2	16	73.5	1922		5.34336	
8	2	16	95.1	1375		6.350663	
9	1	16	67.1			7.353036	
10	1	16	86.7			8.082825	
11	3	16	54.3	1545	1407	8.763266	
12	2	16	100	1300		9.25038	
13	3	16	50.9	1742	1118	10.313675	
14	2	16	97.2	1651		10.509632	
15	2	16	94	1236		11.637543	

Table-6 Radar Type 6 Statistical Performance

Trial #	Fc (MHz)	Pulse /Burst	Pulse Width (µS)	PRI (µs)	Detection (1:yes; 0:no)	Hopping Sequence
1	5490	9	1	333	1	5293.0, 5489.0, 5708.0, 5300.0, 5366.0, 5294.0, 5600.0, 5314.0, 5290.0, 5481.0, 5628.0, 5715.0, 5331.0, 5568.0, 5385.0, 5355.0, 5723.0, 5345.0, 5444.0, 5442.0, 5376.0, 5448.0, 5597.0, 5261.0, 5387.0, 5284.0, 5658.0, 5593.0, 5677.0, 5615.0, 5275.0, 5251.0, 5544.0, 5361.0, 5621.0, 5402.0, 5307.0, 5267.0, 5328.0, 5378.0, 5352.0, 5592.0, 5436.0, 5257.0, 5446.0, 5407.0, 5616.0, 5334.0, 5296.0, 5362.0, 5447.0, 5316.0, 5691.0, 5502.0, 5459.0, 5455.0, 5546.0, 5667.0, 5712.0, 5499.0, 5490.0, 5451.0, 5487.0, 5509.0, 5578.0, 5269.0, 5613.0, 5321.0, 5276.0, 5374.0, 5520.0, 5312.0, 5285.0, 5299.0, 5594.0, 5319.0, 5354.0, 5342.0, 5687.0, 5611.0, 5322.0, 5429.0, 5682.0, 5292.0, 5282.0, 5434.0, 5259.0, 5414.0, 5437.0, 5356.0, 5280.0, 5714.0, 5583.0, 5364.0, 5369.0, 5633.0, 5630.0, 5339.0, 5488.0, 5516.0 (number of hits: 26)
2	5490	9	1	333	1	5522.0, 5524.0, 5579.0, 5692.0, 5256.0, 5272.0, 5577.0, 5527.0, 5410.0, 5662.0, 5576.0, 5462.0, 5398.0, 5553.0, 5327.0, 5394.0, 5470.0, 5306.0, 5550.0, 5723.0, 5531.0, 5493.0, 5404.0, 5262.0, 5438.0, 5653.0, 5287.0, 5693.0, 5608.0, 5663.0, 5333.0, 5456.0, 5455.0, 5260.0, 5341.0, 5483.0, 5504.0, 5337.0, 5353.0, 5548.0, 5323.0, 5298.0, 5681.0, 5469.0, 5332.0, 5587.0, 5533.0, 5301.0, 5582.0, 5347.0, 5334.0, 5299.0, 5367.0, 5539.0, 5434.0, 5375.0, 5321.0, 5330.0, 5620.0, 5595.0, 5279.0, 5619.0, 5618.0, 5393.0, 5258.0, 5685.0, 5308.0, 5479.0, 5391.0, 5416.0, 5373.0, 5405.0, 5650.0, 5708.0, 5515.0, 5271.0, 5549.0, 5453.0, 5270.0, 5709.0, 5574.0, 5680.0, 5426.0, 5263.0, 5707.0, 5684.0, 5255.0, 5335.0, 5561.0, 5267.0, 5629.0, 5513.0, 5613.0, 5387.0, 5397.0, 5704.0, 5307.0, 5467.0, 5377.0, 5311.0 (number of hits: 29)
3	5490	9	1	333	1	5458.0, 5555.0, 5271.0, 5620.0, 5365.0, 5710.0, 5611.0, 5330.0, 5588.0, 5567.0, 5676.0, 5449.0, 5440.0, 5368.0, 5679.0, 5538.0, 5707.0, 5535.0, 5702.0, 5691.0, 5336.0, 5393.0, 5373.0, 5699.0, 5560.0, 5669.0, 5357.0, 5498.0, 5401.0, 5448.0, 5597.0, 5591.0, 5515.0, 5551.0, 5326.0, 5294.0, 5723.0, 5377.0, 5688.0, 5392.0, 5602.0, 5633.0, 5417.0, 5674.0, 5356.0, 5559.0, 5600.0, 5277.0, 5340.0, 5604.0, 5314.0, 5309.0, 5596.0, 5378.0, 5429.0, 5657.0, 5319.0, 5530.0, 5437.0, 5480.0, 5467.0, 5598.0, 5672.0, 5655.0, 5483.0, 5310.0, 5457.0, 5374.0, 5531.0, 5250.0

						5526.0, 5630.0, 5577.0, 5432.0, 5379.0, 5658.0, 5289.0, 5635.0, 5641.0, 5470.0, 5346.0, 5262.0, 5257.0, 5518.0, 5270.0, 5565.0, 5711.0, 5385.0, 5400.0, 5502.0, 5603.0, 5715.0, 5423.0, 5435.0, 5640.0, 5411.0, 5264.0, 5623.0, 5312.0, 5426.0 (number of hits: 32)
4	5490	9	1	333	1	5526.0, 5534.0, 5469.0, 5723.0, 5396.0, 5593.0, 5334.0, 5514.0, 5630.0, 5585.0, 5309.0, 5409.0, 5283.0, 5562.0, 5600.0, 5465.0, 5609.0, 5513.0, 5377.0, 5312.0, 5667.0, 5650.0, 5716.0, 5718.0, 5687.0, 5648.0, 5427.0, 5662.0, 5568.0, 5677.0, 5437.0, 5592.0, 5291.0, 5268.0, 5605.0, 5282.0, 5689.0, 5590.0, 5344.0, 5487.0, 5459.0, 5691.0, 5335.0, 5338.0, 5422.0, 5525.0, 5386.0, 5317.0, 5574.0, 5588.0, 5416.0, 5675.0, 5447.0, 5488.0, 5540.0, 5518.0, 5700.0, 5576.0, 5445.0, 5529.0, 5297.0, 5594.0, 5524.0, 5300.0, 5653.0, 5624.0, 5701.0, 5430.0, 5570.0, 5388.0, 5284.0, 5618.0, 5449.0, 5607.0, 5341.0, 5372.0, 5704.0, 5394.0, 5580.0, 5292.0, 5257.0, 5546.0, 5541.0, 5530.0, 5633.0, 5308.0, 5698.0, 5303.0, 5446.0, 5407.0, 5466.0, 5472.0, 5666.0, 5473.0, 5444.0, 5324.0, 5381.0, 5474.0, 5681.0, 5496.0 (number of hits: 34)
5	5490	9	1	333	1	5613.0, 5521.0, 5711.0, 5719.0, 5710.0, 5281.0, 5484.0, 5308.0, 5714.0, 5359.0, 5464.0, 5512.0, 5580.0, 5273.0, 5456.0, 5555.0, 5720.0, 5626.0, 5347.0, 5313.0, 5255.0, 5505.0, 5437.0, 5407.0, 5258.0, 5378.0, 5628.0, 5299.0, 5397.0, 5701.0, 5450.0, 5356.0, 5413.0, 5707.0, 5481.0, 5652.0, 5645.0, 5514.0, 5489.0, 5708.0, 5549.0, 5660.0, 5522.0, 5285.0, 5523.0, 5276.0, 5681.0, 5578.0, 5485.0, 5455.0, 5328.0, 5624.0, 5428.0, 5344.0, 5266.0, 5604.0, 5594.0, 5595.0, 5630.0, 5677.0, 5278.0, 5275.0, 5702.0, 5475.0, 5409.0, 5322.0, 5357.0, 5348.0, 5252.0, 5705.0, 5500.0, 5504.0, 5554.0, 5490.0, 5421.0, 5659.0, 5443.0, 5367.0, 5724.0, 5487.0, 5412.0, 5341.0, 5339.0, 5309.0, 5672.0, 5387.0, 5552.0, 5384.0, 5333.0, 5274.0, 5458.0, 5452.0, 5670.0, 5250.0, 5577.0, 5671.0, 5584.0, 5486.0, 5427.0, 5515.0 (number of hits: 34)
6	5490	9	1	333	1	5633.0, 5634.0, 5588.0, 5428.0, 5389.0, 5303.0, 5274.0, 5535.0, 5362.0, 5604.0, 5462.0, 5456.0, 5425.0, 5383.0, 5692.0, 5439.0, 5697.0, 5707.0, 5451.0, 5520.0, 5580.0, 5699.0, 5289.0, 5323.0, 5631.0, 5650.0, 5525.0, 5302.0, 5409.0, 5281.0, 5485.0, 5526.0, 5291.0, 5566.0, 5672.0, 5568.0, 5701.0, 5515.0, 5643.0, 5341.0, 5540.0, 5361.0, 5319.0, 5343.0, 5561.0, 5286.0, 5668.0, 5717.0, 5260.0, 5685.0, 5474.0, 5585.0, 5261.0, 5673.0, 5328.0, 5397.0, 5416.0, 5257.0, 5691.0, 5548.0,

						5601.0, 5272.0, 5385.0, 5317.0, 5259.0, 5615.0, 5509.0, 5605.0, 5714.0, 5579.0, 5268.0, 5396.0, 5253.0, 5583.0, 5294.0, 5581.0, 5547.0, 5656.0, 5640.0, 5251.0, 5464.0, 5611.0, 5314.0, 5716.0, 5678.0, 5442.0, 5279.0, 5376.0, 5458.0, 5420.0, 5440.0, 5602.0, 5645.0, 5612.0, 5618.0, 5537.0, 5368.0, 5666.0, 5369.0, 5670.0 (number of hits: 27)
7	5490	9	1	333	1	5538.0, 5425.0, 5354.0, 5661.0, 5512.0, 5542.0, 5494.0, 5692.0, 5375.0, 5624.0, 5338.0, 5583.0, 5499.0, 5250.0, 5558.0, 5357.0, 5592.0, 5443.0, 5563.0, 5678.0, 5660.0, 5273.0, 5551.0, 5708.0, 5722.0, 5321.0, 5700.0, 5662.0, 5461.0, 5337.0, 5665.0, 5546.0, 5513.0, 5318.0, 5410.0, 5258.0, 5467.0, 5457.0, 5627.0, 5470.0, 5351.0, 5527.0, 5276.0, 5324.0, 5645.0, 5464.0, 5576.0, 5382.0, 5638.0, 5333.0, 5567.0, 5501.0, 5381.0, 5294.0, 5553.0, 5430.0, 5447.0, 5703.0, 5518.0, 5531.0, 5265.0, 5401.0, 5372.0, 5286.0, 5637.0, 5626.0, 5514.0, 5356.0, 5274.0, 5604.0, 5262.0, 5698.0, 5612.0, 5609.0, 5423.0, 5348.0, 5335.0, 5569.0, 5263.0, 5330.0, 5502.0, 5432.0, 5426.0, 5481.0, 5283.0, 5524.0, 5642.0, 5392.0, 5405.0, 5659.0, 5474.0, 5292.0, 5723.0, 5293.0, 5399.0, 5647.0, 5322.0, 5600.0, 5707.0, 5614.0 (number of hits: 35)
8	5490	9	1	333	1	5669.0, 5359.0, 5276.0, 5452.0, 5682.0, 5577.0, 5469.0, 5280.0, 5541.0, 5589.0, 5283.0, 5594.0, 5328.0, 5327.0, 5692.0, 5453.0, 5721.0, 5685.0, 5457.0, 5621.0, 5260.0, 5405.0, 5628.0, 5493.0, 5388.0, 5343.0, 5456.0, 5633.0, 5571.0, 5263.0, 5645.0, 5333.0, 5702.0, 5492.0, 5484.0, 5319.0, 5483.0, 5578.0, 5634.0, 5462.0, 5301.0, 5395.0, 5681.0, 5299.0, 5370.0, 5277.0, 5561.0, 5375.0, 5708.0, 5311.0, 5426.0, 5358.0, 5382.0, 5316.0, 5559.0, 5428.0, 5532.0, 5548.0, 5330.0, 5513.0, 5396.0, 5606.0, 5275.0, 5454.0, 5455.0, 5383.0, 5712.0, 5443.0, 5529.0, 5522.0, 5460.0, 5447.0, 5479.0, 5612.0, 5704.0, 5695.0, 5338.0, 5250.0, 5356.0, 5320.0, 5547.0, 5622.0, 5526.0, 5515.0, 5608.0, 5716.0, 5636.0, 5644.0, 5337.0, 5618.0, 5345.0, 5624.0, 5534.0, 5389.0, 5296.0, 5707.0, 5533.0, 5626.0, 5481.0, 5431.0 (number of hits: 33)
9	5490	9	1	333	1	5536.0, 5477.0, 5418.0, 5598.0, 5699.0, 5353.0, 5343.0, 5255.0, 5448.0, 5677.0, 5415.0, 5611.0, 5429.0, 5515.0, 5307.0, 5351.0, 5519.0, 5680.0, 5674.0, 5668.0, 5289.0, 5693.0, 5683.0, 5636.0, 5364.0, 5521.0, 5268.0, 5272.0, 5394.0, 5603.0, 5296.0, 5652.0, 5614.0, 5560.0, 5287.0, 5628.0, 5473.0, 5337.0, 5642.0, 5638.0, 5426.0, 5691.0, 5431.0, 5257.0, 5502.0, 5301.0, 5341.0, 5403.0, 5706.0, 5458.0,

						5432.0, 5550.0, 5622.0, 5498.0, 5327.0, 5278.0, 5689.0, 5310.0, 5723.0, 5522.0, 5252.0, 5454.0, 5264.0, 5596.0, 5256.0, 5527.0, 5681.0, 5469.0, 5497.0, 5599.0, 5593.0, 5314.0, 5655.0, 5433.0, 5322.0, 5298.0, 5670.0, 5446.0, 5420.0, 5606.0, 5708.0, 5507.0, 5533.0, 5509.0, 5348.0, 5456.0, 5716.0, 5387.0, 5717.0, 5511.0, 5623.0, 5495.0, 5585.0, 5401.0, 5444.0, 5696.0, 5609.0, 5526.0, 5532.0, 5374.0 (number of hits: 35)
10	5490	9	1	333	1	5559.0, 5536.0, 5291.0, 5318.0, 5353.0, 5272.0, 5656.0, 5292.0, 5368.0, 5639.0, 5347.0, 5401.0, 5273.0, 5402.0, 5619.0, 5658.0, 5627.0, 5267.0, 5520.0, 5703.0, 5439.0, 5665.0, 5710.0, 5476.0, 5481.0, 5518.0, 5526.0, 5717.0, 5263.0, 5580.0, 5384.0, 5335.0, 5693.0, 5525.0, 5632.0, 5468.0, 5485.0, 5645.0, 5609.0, 5542.0, 5391.0, 5383.0, 5529.0, 5288.0, 5293.0, 5547.0, 5642.0, 5471.0, 5255.0, 5316.0, 5264.0, 5721.0, 5269.0, 5331.0, 5572.0, 5655.0, 5685.0, 5574.0, 5697.0, 5433.0, 5659.0, 5379.0, 5420.0, 5539.0, 5435.0, 5514.0, 5287.0, 5298.0, 5616.0, 5646.0, 5309.0, 5320.0, 5427.0, 5344.0, 5276.0, 5387.0, 5569.0, 5628.0, 5599.0, 5653.0, 5314.0, 5635.0, 5719.0, 5715.0, 5488.0, 5329.0, 5657.0, 5480.0, 5507.0, 5595.0, 5608.0, 5475.0, 5633.0, 5372.0, 5663.0, 5596.0, 5661.0, 5452.0, 5396.0, 5374.0 (number of hits: 27)
11	5570	9	1	333	1	5332.0, 5503.0, 5546.0, 5475.0, 5570.0, 5371.0, 5669.0, 5422.0, 5704.0, 5620.0, 5388.0, 5574.0, 5477.0, 5495.0, 5447.0, 5328.0, 5358.0, 5426.0, 5423.0, 5591.0, 5450.0, 5547.0, 5504.0, 5296.0, 5459.0, 5430.0, 5273.0, 5302.0, 5598.0, 5269.0, 5709.0, 5387.0, 5318.0, 5396.0, 5517.0, 5331.0, 5539.0, 5406.0, 5666.0, 5303.0, 5465.0, 5348.0, 5663.0, 5557.0, 5610.0, 5639.0, 5313.0, 5701.0, 5431.0, 5567.0, 5638.0, 5576.0, 5707.0, 5404.0, 5524.0, 5274.0, 5702.0, 5533.0, 5288.0, 5541.0, 5593.0, 5290.0, 5295.0, 5448.0, 5680.0, 5414.0, 5473.0, 5630.0, 5271.0, 5624.0, 5449.0, 5311.0, 5333.0, 5518.0, 5629.0, 5453.0, 5689.0, 5439.0, 5378.0, 5463.0, 5578.0, 5397.0, 5515.0, 5606.0, 5676.0, 5592.0, 5712.0, 5573.0, 5648.0, 5690.0, 5367.0, 5282.0, 5611.0, 5305.0, 5272.0, 5613.0, 5655.0, 5687.0, 5488.0, 5486.0 (number of hits: 34)
12	5570	9	1	333	1	5585.0, 5450.0, 5350.0, 5641.0, 5453.0, 5316.0, 5402.0, 5281.0, 5689.0, 5680.0, 5478.0, 5575.0, 5312.0, 5565.0, 5596.0, 5556.0, 5392.0, 5252.0, 5713.0, 5463.0, 5395.0, 5261.0, 5589.0, 5380.0, 5558.0, 5630.0, 5344.0, 5404.0, 5370.0, 5479.0, 5707.0, 5666.0, 5720.0, 5626.0, 5465.0, 5637.0, 5475.0, 5275.0, 5610.0, 5445.0,

						5648.0, 5397.0, 5522.0, 5431.0, 5351.0, 5533.0, 5401.0, 5300.0, 5335.0, 5251.0, 5509.0, 5545.0, 5430.0, 5356.0, 5654.0, 5314.0, 5502.0, 5706.0, 5357.0, 5557.0, 5543.0, 5349.0, 5330.0, 5625.0, 5660.0, 5598.0, 5464.0, 5452.0, 5555.0, 5719.0, 5444.0, 5671.0, 5382.0, 5649.0, 5457.0, 5655.0, 5615.0, 5327.0, 5265.0, 5291.0, 5365.0, 5298.0, 5687.0, 5663.0, 5250.0, 5424.0, 5700.0, 5645.0, 5413.0, 5420.0, 5418.0, 5675.0, 5642.0, 5334.0, 5595.0, 5317.0, 5268.0, 5345.0, 5483.0, 5668.0 (number of hits: 28)
13	5570	9	1	333	1	5555.0, 5361.0, 5365.0, 5480.0, 5694.0, 5306.0, 5269.0, 5404.0, 5519.0, 5719.0, 5390.0, 5307.0, 5360.0, 5627.0, 5510.0, 5533.0, 5708.0, 5681.0, 5683.0, 5501.0, 5570.0, 5324.0, 5483.0, 5588.0, 5544.0, 5606.0, 5251.0, 5294.0, 5474.0, 5508.0, 5397.0, 5465.0, 5571.0, 5717.0, 5500.0, 5351.0, 5670.0, 5290.0, 5652.0, 5319.0, 5599.0, 5352.0, 5596.0, 5346.0, 5577.0, 5451.0, 5291.0, 5641.0, 5593.0, 5358.0, 5590.0, 5378.0, 5644.0, 5484.0, 5651.0, 5370.0, 5495.0, 5399.0, 5347.0, 5371.0, 5605.0, 5553.0, 5409.0, 5466.0, 5376.0, 5325.0, 5354.0, 5564.0, 5687.0, 5492.0, 5666.0, 5673.0, 5649.0, 5603.0, 5700.0, 5267.0, 5530.0, 5429.0, 5276.0, 5448.0, 5470.0, 5334.0, 5486.0, 5482.0, 5401.0, 5572.0, 5443.0, 5382.0, 5669.0, 5531.0, 5415.0, 5332.0, 5445.0, 5540.0, 5668.0, 5567.0, 5648.0, 5279.0, 5714.0, 5541.0 (number of hits: 34)
14	5570	9	1	333	1	5655.0, 5699.0, 5344.0, 5568.0, 5341.0, 5491.0, 5381.0, 5347.0, 5688.0, 5505.0, 5471.0, 5689.0, 5604.0, 5581.0, 5340.0, 5509.0, 5608.0, 5533.0, 5686.0, 5517.0, 5375.0, 5543.0, 5254.0, 5363.0, 5305.0, 5495.0, 5269.0, 5673.0, 5527.0, 5422.0, 5415.0, 5361.0, 5605.0, 5639.0, 5271.0, 5316.0, 5425.0, 5287.0, 5455.0, 5411.0, 5438.0, 5337.0, 5380.0, 5284.0, 5379.0, 5644.0, 5620.0, 5338.0, 5563.0, 5279.0, 5577.0, 5388.0, 5523.0, 5359.0, 5512.0, 5683.0, 5252.0, 5373.0, 5631.0, 5350.0, 5461.0, 5275.0, 5613.0, 5658.0, 5384.0, 5515.0, 5532.0, 5669.0, 5368.0, 5413.0, 5281.0, 5615.0, 5433.0, 5609.0, 5700.0, 5463.0, 5432.0, 5675.0, 5366.0, 5628.0, 5289.0, 5698.0, 5481.0, 5426.0, 5335.0, 5260.0, 5313.0, 5414.0, 5352.0, 5638.0, 5665.0, 5370.0, 5417.0, 5677.0, 5318.0, 5294.0, 5412.0, 5591.0, 5266.0, 5497.0 (number of hits: 30)
15	5570	9	1	333	1	5519.0, 5501.0, 5579.0, 5714.0, 5607.0, 5419.0, 5426.0, 5339.0, 5576.0, 5551.0, 5667.0, 5593.0, 5588.0, 5560.0, 5444.0, 5698.0, 5541.0, 5640.0, 5448.0, 5684.0, 5462.0, 5515.0, 5683.0, 5287.0, 5678.0, 5663.0, 5697.0, 5623.0, 5657.0, 5712.0,

						5630.0, 5702.0, 5354.0, 5661.0, 5720.0, 5562.0, 5305.0, 5591.0, 5710.0, 5597.0, 5520.0, 5376.0, 5477.0, 5644.0, 5277.0, 5423.0, 5476.0, 5407.0, 5495.0, 5308.0, 5693.0, 5451.0, 5414.0, 5599.0, 5409.0, 5439.0, 5559.0, 5399.0, 5554.0, 5689.0, 5367.0, 5577.0, 5468.0, 5646.0, 5722.0, 5413.0, 5574.0, 5524.0, 5645.0, 5718.0, 5484.0, 5564.0, 5320.0, 5585.0, 5391.0, 5465.0, 5525.0, 5594.0, 5573.0, 5568.0, 5621.0, 5719.0, 5297.0, 5660.0, 5550.0, 5658.0, 5668.0, 5333.0, 5604.0, 5544.0, 5479.0, 5701.0, 5587.0, 5649.0, 5258.0, 5584.0, 5482.0, 5312.0, 5395.0, 5567.0 (number of hits: 42)
16	5570	9	1	333	1	5363.0, 5453.0, 5472.0, 5270.0, 5346.0, 5697.0, 5386.0, 5693.0, 5627.0, 5577.0, 5460.0, 5275.0, 5430.0, 5668.0, 5494.0, 5613.0, 5310.0, 5469.0, 5385.0, 5279.0, 5574.0, 5288.0, 5678.0, 5351.0, 5394.0, 5414.0, 5425.0, 5520.0, 5554.0, 5317.0, 5611.0, 5442.0, 5591.0, 5371.0, 5412.0, 5621.0, 5320.0, 5367.0, 5312.0, 5325.0, 5444.0, 5720.0, 5429.0, 5427.0, 5459.0, 5448.0, 5353.0, 5576.0, 5533.0, 5399.0, 5375.0, 5372.0, 5682.0, 5702.0, 5675.0, 5344.0, 5276.0, 5397.0, 5564.0, 5604.0, 5501.0, 5565.0, 5598.0, 5480.0, 5328.0, 5290.0, 5406.0, 5632.0, 5662.0, 5253.0, 5592.0, 5424.0, 5281.0, 5539.0, 5514.0, 5342.0, 5630.0, 5318.0, 5360.0, 5339.0, 5530.0, 5567.0, 5302.0, 5340.0, 5559.0, 5552.0, 5589.0, 5709.0, 5404.0, 5407.0, 5596.0, 5666.0, 5390.0, 5343.0, 5684.0, 5521.0, 5474.0, 5366.0, 5326.0, 5517.0 (number of hits: 30)
17	5570	9	1	333	1	5273.0, 5581.0, 5299.0, 5695.0, 5584.0, 5469.0, 5659.0, 5690.0, 5279.0, 5416.0, 5428.0, 5615.0, 5382.0, 5444.0, 5432.0, 5708.0, 5622.0, 5579.0, 5455.0, 5702.0, 5724.0, 5638.0, 5481.0, 5641.0, 5300.0, 5308.0, 5344.0, 5571.0, 5378.0, 5463.0, 5272.0, 5563.0, 5395.0, 5372.0, 5618.0, 5700.0, 5514.0, 5539.0, 5522.0, 5605.0, 5376.0, 5644.0, 5289.0, 5536.0, 5286.0, 5495.0, 5307.0, 5370.0, 5715.0, 5421.0, 5314.0, 5586.0, 5613.0, 5450.0, 5365.0, 5256.0, 5565.0, 5673.0, 5566.0, 5281.0, 5349.0, 5684.0, 5722.0, 5302.0, 5417.0, 5364.0, 5460.0, 5720.0, 5284.0, 5614.0, 5327.0, 5451.0, 5362.0, 5448.0, 5707.0, 5368.0, 5721.0, 5531.0, 5547.0, 5521.0, 5338.0, 5435.0, 5377.0, 5558.0, 5532.0, 5414.0, 5701.0, 5570.0, 5363.0, 5304.0, 5620.0, 5517.0, 5528.0, 5704.0, 5482.0, 5664.0, 5291.0, 5621.0, 5507.0, 5668.0 (number of hits: 33)
18	5570	9	1	333	1	5302.0, 5273.0, 5720.0, 5343.0, 5350.0, 5628.0, 5455.0, 5463.0, 5407.0, 5481.0, 5434.0, 5693.0, 5439.0, 5661.0, 5684.0, 5630.0, 5389.0, 5388.0, 5620.0, 5254.0,

						5651.0, 5643.0, 5445.0, 5514.0, 5366.0, 5467.0, 5504.0, 5568.0, 5597.0, 5552.0, 5488.0, 5634.0, 5696.0, 5613.0, 5515.0, 5306.0, 5417.0, 5656.0, 5278.0, 5269.0, 5436.0, 5525.0, 5391.0, 5478.0, 5373.0, 5329.0, 5554.0, 5370.0, 5381.0, 5543.0, 5622.0, 5724.0, 5364.0, 5301.0, 5530.0, 5602.0, 5334.0, 5292.0, 5258.0, 5299.0, 5261.0, 5353.0, 5669.0, 5667.0, 5265.0, 5279.0, 5577.0, 5606.0, 5460.0, 5564.0, 5545.0, 5636.0, 5526.0, 5502.0, 5524.0, 5495.0, 5426.0, 5521.0, 5456.0, 5575.0, 5405.0, 5712.0, 5416.0, 5677.0, 5362.0, 5422.0, 5357.0, 5711.0, 5276.0, 5441.0, 5531.0, 5687.0, 5616.0, 5482.0, 5609.0, 5716.0, 5394.0, 5476.0, 5633.0, 5536.0 (number of hits: 34)
19	5570	9	1	333	1	5714.0, 5401.0, 5256.0, 5572.0, 5409.0, 5553.0, 5530.0, 5467.0, 5265.0, 5413.0, 5539.0, 5658.0, 5688.0, 5618.0, 5495.0, 5624.0, 5705.0, 5284.0, 5565.0, 5480.0, 5653.0, 5404.0, 5533.0, 5615.0, 5657.0, 5351.0, 5355.0, 5440.0, 5620.0, 5403.0, 5472.0, 5348.0, 5275.0, 5690.0, 5510.0, 5255.0, 5452.0, 5301.0, 5711.0, 5457.0, 5608.0, 5648.0, 5425.0, 5451.0, 5513.0, 5555.0, 5419.0, 5361.0, 5415.0, 5693.0, 5528.0, 5288.0, 5505.0, 5370.0, 5584.0, 5276.0, 5564.0, 5721.0, 5524.0, 5364.0, 5378.0, 5439.0, 5272.0, 5630.0, 5652.0, 5574.0, 5716.0, 5613.0, 5349.0, 5261.0, 5446.0, 5698.0, 5668.0, 5517.0, 5318.0, 5313.0, 5544.0, 5344.0, 5292.0, 5277.0, 5462.0, 5703.0, 5309.0, 5647.0, 5518.0, 5326.0, 5422.0, 5385.0, 5722.0, 5317.0, 5294.0, 5549.0, 5611.0, 5509.0, 5431.0, 5295.0, 5473.0, 5345.0, 5586.0, 5290.0 (number of hits: 32)
20	5570	9	1	333	1	5519.0, 5263.0, 5306.0, 5617.0, 5381.0, 5429.0, 5546.0, 5433.0, 5341.0, 5697.0, 5530.0, 5374.0, 5394.0, 5557.0, 5536.0, 5658.0, 5523.0, 5356.0, 5547.0, 5552.0, 5531.0, 5655.0, 5323.0, 5698.0, 5574.0, 5678.0, 5333.0, 5581.0, 5721.0, 5662.0, 5317.0, 5598.0, 5376.0, 5396.0, 5384.0, 5469.0, 5271.0, 5677.0, 5642.0, 5478.0, 5657.0, 5520.0, 5412.0, 5479.0, 5416.0, 5712.0, 5580.0, 5458.0, 5505.0, 5686.0, 5463.0, 5369.0, 5366.0, 5313.0, 5506.0, 5488.0, 5315.0, 5292.0, 5360.0, 5569.0, 5257.0, 5477.0, 5532.0, 5324.0, 5452.0, 5717.0, 5407.0, 5440.0, 5386.0, 5308.0, 5515.0, 5538.0, 5516.0, 5399.0, 5550.0, 5439.0, 5335.0, 5294.0, 5600.0, 5283.0, 5708.0, 5268.0, 5289.0, 5280.0, 5352.0, 5395.0, 5453.0, 5461.0, 5639.0, 5508.0, 5427.0, 5606.0, 5261.0, 5570.0, 5589.0, 5476.0, 5424.0, 5284.0, 5483.0, 5595.0 (number of hits: 31)
21	5650	9	1	333	1	5342.0, 5452.0, 5588.0, 5426.0, 5570.0, 5421.0, 5635.0, 5447.0, 5684.0, 5572.0,

						5517.0, 5317.0, 5620.0, 5399.0, 5699.0, 5386.0, 5274.0, 5278.0, 5680.0, 5459.0, 5495.0, 5723.0, 5710.0, 5528.0, 5465.0, 5418.0, 5348.0, 5297.0, 5700.0, 5589.0, 5548.0, 5250.0, 5514.0, 5532.0, 5545.0, 5305.0, 5554.0, 5577.0, 5576.0, 5464.0, 5273.0, 5378.0, 5354.0, 5515.0, 5611.0, 5520.0, 5253.0, 5674.0, 5423.0, 5311.0, 5653.0, 5633.0, 5446.0, 5659.0, 5327.0, 5587.0, 5289.0, 5288.0, 5440.0, 5579.0, 5261.0, 5609.0, 5419.0, 5347.0, 5283.0, 5484.0, 5542.0, 5698.0, 5480.0, 5512.0, 5444.0, 5478.0, 5436.0, 5538.0, 5675.0, 5585.0, 5678.0, 5615.0, 5296.0, 5619.0, 5686.0, 5652.0, 5670.0, 5306.0, 5481.0, 5646.0, 5256.0, 5683.0, 5295.0, 5387.0, 5346.0, 5506.0, 5315.0, 5604.0, 5607.0, 5328.0, 5364.0, 5713.0, 5682.0, 5580.0 (number of hits: 38)
22	5650	9	1	333	1	5528.0, 5589.0, 5502.0, 5316.0, 5652.0, 5255.0, 5315.0, 5506.0, 5400.0, 5685.0, 5447.0, 5487.0, 5442.0, 5531.0, 5522.0, 5569.0, 5334.0, 5300.0, 5491.0, 5281.0, 5460.0, 5260.0, 5371.0, 5388.0, 5445.0, 5670.0, 5601.0, 5673.0, 5343.0, 5328.0, 5520.0, 5659.0, 5264.0, 5417.0, 5710.0, 5635.0, 5560.0, 5682.0, 5548.0, 5406.0, 5543.0, 5389.0, 5425.0, 5284.0, 5707.0, 5714.0, 5340.0, 5582.0, 5468.0, 5378.0, 5443.0, 5712.0, 5574.0, 5321.0, 5616.0, 5333.0, 5677.0, 5419.0, 5352.0, 5473.0, 5537.0, 5626.0, 5719.0, 5356.0, 5486.0, 5643.0, 5278.0, 5615.0, 5695.0, 5259.0, 5656.0, 5690.0, 5347.0, 5555.0, 5287.0, 5444.0, 5529.0, 5355.0, 5499.0, 5485.0, 5546.0, 5508.0, 5606.0, 5724.0, 5530.0, 5435.0, 5318.0, 5688.0, 5359.0, 5270.0, 5583.0, 5266.0, 5651.0, 5584.0, 5483.0, 5619.0, 5267.0, 5423.0, 5591.0, 5258.0 (number of hits: 32)
23	5650	9	1	333	1	5301.0, 5478.0, 5394.0, 5652.0, 5559.0, 5330.0, 5484.0, 5285.0, 5518.0, 5656.0, 5614.0, 5671.0, 5555.0, 5681.0, 5267.0, 5464.0, 5517.0, 5412.0, 5718.0, 5487.0, 5588.0, 5476.0, 5630.0, 5477.0, 5378.0, 5485.0, 5379.0, 5596.0, 5366.0, 5499.0, 5298.0, 5698.0, 5675.0, 5253.0, 5435.0, 5389.0, 5547.0, 5584.0, 5494.0, 5578.0, 5631.0, 5415.0, 5636.0, 5360.0, 5356.0, 5556.0, 5313.0, 5414.0, 5488.0, 5372.0, 5336.0, 5266.0, 5395.0, 5462.0, 5629.0, 5377.0, 5480.0, 5701.0, 5409.0, 5335.0, 5383.0, 5551.0, 5595.0, 5357.0, 5261.0, 5689.0, 5344.0, 5269.0, 5380.0, 5489.0, 5340.0, 5580.0, 5686.0, 5323.0, 5255.0, 5469.0, 5628.0, 5526.0, 5281.0, 5531.0, 5587.0, 5459.0, 5273.0, 5610.0, 5418.0, 5696.0, 5427.0, 5682.0, 5532.0, 5448.0, 5280.0, 5713.0, 5467.0, 5707.0, 5525.0, 5619.0, 5439.0, 5327.0, 5513.0, 5645.0 (number of hits: 30)

24	5650	9	1	333	1	5681.0, 5688.0, 5631.0, 5536.0, 5275.0, 5569.0, 5638.0, 5608.0, 5705.0, 5430.0, 5385.0, 5555.0, 5639.0, 5384.0, 5648.0, 5394.0, 5523.0, 5514.0, 5439.0, 5543.0, 5362.0, 5621.0, 5578.0, 5409.0, 5625.0, 5568.0, 5336.0, 5594.0, 5492.0, 5483.0, 5454.0, 5502.0, 5331.0, 5654.0, 5290.0, 5658.0, 5294.0, 5698.0, 5610.0, 5308.0, 5265.0, 5547.0, 5392.0, 5291.0, 5418.0, 5332.0, 5387.0, 5490.0, 5718.0, 5329.0, 5335.0, 5452.0, 5306.0, 5525.0, 5343.0, 5694.0, 5557.0, 5375.0, 5253.0, 5722.0, 5539.0, 5661.0, 5635.0, 5613.0, 5281.0, 5413.0, 5674.0, 5526.0, 5570.0, 5524.0, 5250.0, 5634.0, 5666.0, 5262.0, 5383.0, 5270.0, 5386.0, 5545.0, 5651.0, 5304.0, 5346.0, 5719.0, 5431.0, 5441.0, 5380.0, 5446.0, 5679.0, 5303.0, 5353.0, 5472.0, 5356.0, 5438.0, 5535.0, 5277.0, 5617.0, 5473.0, 5645.0, 5318.0, 5503.0, 5509.0 (number of hits: 31)
25	5650	9	1	333	1	5601.0, 5253.0, 5602.0, 5424.0, 5633.0, 5417.0, 5621.0, 5707.0, 5634.0, 5723.0, 5421.0, 5635.0, 5689.0, 5311.0, 5606.0, 5440.0, 5494.0, 5504.0, 5560.0, 5447.0, 5610.0, 5282.0, 5482.0, 5670.0, 5312.0, 5540.0, 5391.0, 5403.0, 5538.0, 5306.0, 5381.0, 5474.0, 5648.0, 5619.0, 5657.0, 5255.0, 5360.0, 5699.0, 5649.0, 5302.0, 5603.0, 5413.0, 5706.0, 5571.0, 5453.0, 5582.0, 5704.0, 5480.0, 5400.0, 5615.0, 5412.0, 5630.0, 5409.0, 5478.0, 5484.0, 5692.0, 5352.0, 5395.0, 5677.0, 5250.0, 5556.0, 5681.0, 5547.0, 5291.0, 5266.0, 5503.0, 5376.0, 5493.0, 5642.0, 5334.0, 5374.0, 5672.0, 5598.0, 5490.0, 5326.0, 5620.0, 5555.0, 5519.0, 5554.0, 5317.0, 5628.0, 5660.0, 5680.0, 5703.0, 5527.0, 5372.0, 5396.0, 5512.0, 5339.0, 5697.0, 5584.0, 5390.0, 5422.0, 5439.0, 5476.0, 5576.0, 5492.0, 5682.0, 5579.0, 5604.0 (number of hits: 41)
26	5650	9	1	333	1	5345.0, 5319.0, 5489.0, 5511.0, 5302.0, 5658.0, 5536.0, 5665.0, 5507.0, 5675.0, 5578.0, 5268.0, 5443.0, 5623.0, 5258.0, 5724.0, 5380.0, 5531.0, 5561.0, 5525.0, 5555.0, 5572.0, 5334.0, 5474.0, 5565.0, 5527.0, 5521.0, 5293.0, 5287.0, 5395.0, 5596.0, 5469.0, 5687.0, 5399.0, 5383.0, 5682.0, 5679.0, 5259.0, 5574.0, 5552.0, 5442.0, 5508.0, 5690.0, 5649.0, 5476.0, 5308.0, 5304.0, 5415.0, 5721.0, 5542.0, 5550.0, 5710.0, 5631.0, 5580.0, 5471.0, 5275.0, 5270.0, 5570.0, 5585.0, 5671.0, 5479.0, 5277.0, 5715.0, 5638.0, 5388.0, 5387.0, 5510.0, 5543.0, 5310.0, 5262.0, 5318.0, 5358.0, 5523.0, 5424.0, 5455.0, 5286.0, 5609.0, 5420.0, 5481.0, 5630.0, 5447.0, 5695.0, 5686.0, 5663.0, 5458.0, 5549.0, 5356.0, 5517.0, 5486.0, 5528.0, 5676.0, 5713.0, 5594.0, 5403.0, 5468.0,

						5296.0, 5324.0, 5385.0, 5621.0, 5705.0 (number of hits: 33)
27	5650	9	1	333	1	5630.0, 5688.0, 5678.0, 5669.0, 5310.0, 5502.0, 5468.0, 5506.0, 5540.0, 5364.0, 5592.0, 5500.0, 5261.0, 5559.0, 5563.0, 5436.0, 5486.0, 5414.0, 5400.0, 5450.0, 5672.0, 5528.0, 5452.0, 5652.0, 5664.0, 5305.0, 5516.0, 5417.0, 5322.0, 5423.0, 5455.0, 5283.0, 5447.0, 5304.0, 5619.0, 5330.0, 5714.0, 5504.0, 5491.0, 5685.0, 5627.0, 5558.0, 5604.0, 5268.0, 5537.0, 5397.0, 5324.0, 5457.0, 5560.0, 5275.0, 5412.0, 5281.0, 5525.0, 5471.0, 5613.0, 5383.0, 5643.0, 5597.0, 5431.0, 5426.0, 5702.0, 5684.0, 5689.0, 5677.0, 5708.0, 5671.0, 5290.0, 5587.0, 5711.0, 5359.0, 5467.0, 5269.0, 5526.0, 5663.0, 5556.0, 5367.0, 5665.0, 5690.0, 5586.0, 5425.0, 5546.0, 5321.0, 5522.0, 5314.0, 5347.0, 5693.0, 5262.0, 5575.0, 5656.0, 5577.0, 5443.0, 5644.0, 5462.0, 5401.0, 5611.0, 5606.0, 5511.0, 5440.0, 5692.0, 5413.0 (number of hits: 36)
28	5650	9	1	333	1	5640.0, 5615.0, 5470.0, 5345.0, 5393.0, 5568.0, 5410.0, 5661.0, 5677.0, 5440.0, 5548.0, 5384.0, 5266.0, 5354.0, 5490.0, 5464.0, 5555.0, 5290.0, 5357.0, 5662.0, 5597.0, 5558.0, 5349.0, 5567.0, 5553.0, 5506.0, 5338.0, 5444.0, 5320.0, 5288.0, 5453.0, 5292.0, 5631.0, 5698.0, 5287.0, 5477.0, 5356.0, 5443.0, 5463.0, 5606.0, 5277.0, 5497.0, 5611.0, 5547.0, 5704.0, 5613.0, 5311.0, 5621.0, 5575.0, 5560.0, 5307.0, 5630.0, 5610.0, 5539.0, 5515.0, 5295.0, 5692.0, 5314.0, 5717.0, 5579.0, 5422.0, 5650.0, 5557.0, 5624.0, 5328.0, 5317.0, 5251.0, 5258.0, 5379.0, 5641.0, 5376.0, 5632.0, 5298.0, 5682.0, 5431.0, 5482.0, 5524.0, 5562.0, 5268.0, 5252.0, 5673.0, 5572.0, 5554.0, 5333.0, 5480.0, 5657.0, 5405.0, 5353.0, 5341.0, 5262.0, 5538.0, 5267.0, 5391.0, 5293.0, 5352.0, 5518.0, 5362.0, 5387.0, 5638.0, 5714.0 (number of hits: 29)
29	5650	9	1	333	1	5463.0, 5697.0, 5461.0, 5550.0, 5672.0, 5650.0, 5649.0, 5377.0, 5322.0, 5494.0, 5623.0, 5367.0, 5531.0, 5570.0, 5557.0, 5353.0, 5595.0, 5590.0, 5721.0, 5532.0, 5669.0, 5276.0, 5483.0, 5601.0, 5492.0, 5421.0, 5404.0, 5480.0, 5366.0, 5318.0, 5644.0, 5415.0, 5425.0, 5657.0, 5517.0, 5493.0, 5274.0, 5621.0, 5491.0, 5448.0, 5394.0, 5429.0, 5591.0, 5476.0, 5469.0, 5718.0, 5467.0, 5652.0, 5723.0, 5582.0, 5706.0, 5629.0, 5656.0, 5363.0, 5424.0, 5564.0, 5528.0, 5464.0, 5376.0, 5713.0, 5451.0, 5643.0, 5690.0, 5577.0, 5446.0, 5568.0, 5640.0, 5393.0, 5412.0, 5312.0, 5253.0, 5612.0, 5285.0, 5345.0, 5416.0, 5711.0, 5692.0, 5311.0, 5305.0, 5400.0, 5450.0, 5454.0, 5495.0, 5302.0, 5326.0,

						5382.0, 5578.0, 5507.0, 5543.0, 5458.0, 5308.0, 5490.0, 5693.0, 5282.0, 5719.0, 5611.0, 5695.0, 5330.0, 5321.0, 5399.0 (number of hits: 35)
30	5650	9	1	333	1	5260.0, 5336.0, 5470.0, 5673.0, 5289.0, 5299.0, 5343.0, 5409.0, 5490.0, 5286.0, 5366.0, 5515.0, 5590.0, 5506.0, 5682.0, 5288.0, 5406.0, 5646.0, 5429.0, 5712.0, 5467.0, 5421.0, 5332.0, 5493.0, 5556.0, 5666.0, 5361.0, 5549.0, 5608.0, 5354.0, 5312.0, 5495.0, 5314.0, 5664.0, 5610.0, 5389.0, 5363.0, 5578.0, 5703.0, 5532.0, 5579.0, 5498.0, 5587.0, 5459.0, 5384.0, 5638.0, 5525.0, 5328.0, 5684.0, 5396.0, 5270.0, 5329.0, 5301.0, 5533.0, 5365.0, 5497.0, 5373.0, 5302.0, 5617.0, 5602.0, 5508.0, 5341.0, 5397.0, 5440.0, 5259.0, 5485.0, 5708.0, 5349.0, 5635.0, 5637.0, 5616.0, 5530.0, 5580.0, 5275.0, 5705.0, 5313.0, 5370.0, 5692.0, 5405.0, 5722.0, 5603.0, 5350.0, 5334.0, 5424.0, 5565.0, 5355.0, 5326.0, 5691.0, 5476.0, 5469.0, 5318.0, 5620.0, 5634.0, 5287.0, 5670.0, 5282.0, 5688.0, 5371.0, 5581.0, 5269.0 (number of hits: 32)