

Test Report

IW-6300H Series Access Point

Cisco Industrial Wireless Hazardous Location Access Point

FCC ID: LDKESW6300
IC ID: 2461D-ESW6300

5725-5850 MHz

Outside Antennas, 7dBi Gain

Against the following Specifications:

CFR47 Part 15.407

RSS-247



Cisco Systems

170 West Tasman Drive

San Jose, CA 95134

	
Author: Julian Land Tested By: Julian Land	Approved By: Adam Walb Title: MGR. IoT Compliance Revision: 1.0

This report replaces any previously entered test report under EDCS – **18429932**. This test report has been electronically authorized and archived using the CISCO Engineering Document Control system.

This test report has been electronically authorized and archived using the CISCO Engineering Document Control system.

SECTION 1: OVERVIEW	3
SECTION 2: ASSESSMENT INFORMATION	4
2.1 GENERAL	4
2.2 DATE OF TESTING.....	6
2.3 REPORT ISSUE DATE	6
2.4 TESTING FACILITIES	6
2.5 EQUIPMENT ASSESSED (EUT).....	6
2.6 EUT DESCRIPTION.....	7
SECTION 3: RESULT SUMMARY.....	10
3.1 RESULTS SUMMARY TABLE	10
SECTION 4: SAMPLE DETAILS.....	11
4.1 SAMPLE DETAILS.....	11
4.2 SYSTEM DETAILS.....	11
4.3 MODE OF OPERATION DETAILS.....	11
APPENDIX A: EMISSION TEST RESULTS	12
CONDUCTED TEST SETUP DIAGRAM.....	12
TARGET MAXIMUM CHANNEL POWER	12
A.1 DUTY CYCLE	13
A.2 6DB BANDWIDTH.....	16
A.3 99% AND 26DB BANDWIDTH.....	19
A.4 MAXIMUM CONDUCTED OUTPUT POWER	22
A.5 POWER SPECTRAL DENSITY	26
A.6 CONDUCTED SPURIOUS EMISSIONS	30
A.7 CONDUCTED BANDEDGE.....	39
APPENDIX B: LIST OF TEST EQUIPMENT USED TO PERFORM THE TEST.....	47
APPENDIX C: ABBREVIATION KEY AND DEFINITIONS.....	48
APPENDIX D: PHOTOGRAPHS OF TEST SETUPS	49
APPENDIX E: SOFTWARE USED TO PERFORM TESTING.....	52
APPENDIX F: TEST PROCEDURES	53
APPENDIX G: SCOPE OF ACCREDITATION (A2LA CERTIFICATE NUMBER 1178-01).....	54

Section 1: Overview

The samples were assessed against the tests detailed in section 3 under the requirements of the following specifications:

Specifications:
CFR47 Part 15.407 RSS-247

Measurements were made in accordance with

- ANSI C63.10:2013
- KDB 789033 D02 General UNII Test Procedures New Rules v01r03
- KDB 662911 D01 Multiple Transmitter Output v02r01

Section 2: Assessment Information

2.1 General

This report contains an assessment of an apparatus against Electromagnetic Compatibility Standards based upon tests carried out on the samples submitted. The testing was performed by and for the use of Cisco systems Inc:

With regard to this assessment, the following points should be noted:

- a) The results contained in this report relate only to the items tested and were obtained in the period between the date of the initial assessment and the date of issue of the report. Manufactured products will not necessarily give identical results due to production and measurement tolerances.
- b) The apparatus was set up and exercised using the configuration and modes of operation defined in this report only.
- c) Where relevant, the apparatus was only assessed using the susceptibility criteria defined in this report and the Test Assessment Plan (TAP).
- d) All testing was performed under the following environmental conditions:

Temperature	15°C to 35°C (54°F to 95°F)
Atmospheric Pressure	860mbar to 1060mbar (25.4" to 31.3")
Humidity	10% to 75*%
- e) All AC testing was performed at one or more of the following supply voltages:
110V 60 Hz (+/-20%)

Units of Measurement

The units of measurements defined in the appendices are reported in specific terms, which are test dependent. Where radiated measurements are concerned these are defined at a particular distance. Basic voltage measurements are defined in units of [dBuV]

As an example, the basic calculation for all measurements is as follows:

$$\text{Emission level [dBuV]} = \text{Indicated voltage level [dBuV]} + \text{Cable Loss [dB]} + \text{Other correction factors [dB]}$$

The combinations of correction factors are dependent upon the exact test configurations [see test equipment lists for further details] and may include:-

Antenna Factors, Pre Amplifier Gain, LISN Loss, Pulse Limiter Loss and Filter Insertion Loss

Note: to convert the results from dBuV/m to uV/m use the following formula:-

$$\text{Level in uV/m} = \text{Common Antilogarithm} [(X \text{ dBuV/m})/20] = Y \text{ uV/m}$$

Measurement Uncertainty Values

voltage and power measurements	± 2 dB
conducted EIRP measurements	± 1.4 dB
radiated measurements	± 3.2 dB
frequency measurements	± 2.4 10 ⁻⁷
temperature measurements	± 0.54°
humidity measurements	± 2.3%
DC and low frequency measurements	± 2.5%

Where relevant measurement uncertainty levels have been estimated for tests performed on the apparatus. This uncertainty represents an expanded uncertainty expressed at approximately the 95% confidence level using a coverage factor of k=2.

Radiated emissions (expanded uncertainty, confidence interval 95%)

30 MHz - 300 MHz	+/- 3.8 dB
300 MHz - 1000 MHz	+/- 4.3 dB
1 GHz - 10 GHz	+/- 4.0 dB
10 GHz - 18GHz	+/- 8.2 dB
18GHz - 26.5GHz	+/- 4.1 dB
26.5GHz - 40GHz	+/- 3.9 dB

Conducted emissions (expanded uncertainty, confidence interval 95%)

30 MHz – 40GHz	+/- 0.38 dB
----------------	-------------

A product is considered to comply with a requirement if the nominal measured value is below the limit line. The product is considered to not be in compliance in case the nominal measured value is above the limit line.

This report must not be reproduced except in full, without written approval of Cisco Systems.

2.2 Date of testing

04-Oct-19 - 05-Oct-19

2.3 Report Issue Date

11/14/2019

Cisco uses an electronic system to issue, store and control the revision of test reports. This system is called the Engineering Document Control System (EDCS). The actual report issue date is embedded into the original file on EDCS. Any copies of this report, either electronic or paper, that are not on EDCS must be considered uncontrolled.

2.4 Testing facilities

This assessment was performed by:

Testing Laboratory

Cisco Systems, Inc.,
125 West Tasman Drive
San Jose, CA 95134, USA

Registration Numbers for Industry Canada

Cisco System Site	Address	Site Identifier
Building P, 10m Chamber	125 West Tasman Dr San Jose, CA 95134	Company #: 2461N-2
Building P, 5m Chamber	125 West Tasman Dr San Jose, CA 95134	Company #: 2461N-1
Building I, 5m Chamber	285 W. Tasman Drive San Jose, California 95134	Company #: 2461M-1

Test Engineers

Julian Land

2.5 Equipment Assessed (EUT)

IW 6300H

2.6 EUT Description

The Cisco Aironet 802.11ac Radio supports the following modes of operation. The modes are further defined in the radio Theory of Operation. The modes included in this report represent the worst case data for all modes.

- 802.11a - Non HT20, Two Antennas, 6 to 54 Mbps, 1ss
- 802.11a - Non HT20 Beam Forming, Two Antennas, 6 to 54 Mbps, 1ss
- 802.11n/ac - HT/VHT20, One Antenna, M0 to M7, 1ss
- 802.11n/ac - HT/VHT20, Two Antennas, M0 to M7, 1ss
- 802.11n/ac - HT/VHT20, Two Antennas, M8 to M15, 2ss
- 802.11n/ac - HT/VHT20 Beam Forming, Two Antennas, M0 to M7, 1ss
- 802.11n/ac - HT/VHT20 Beam Forming, Two Antennas, M8 to M15, 2ss
- 802.11n/ac - HT/VHT20 STBC, Two Antennas, M0 to M7, 2ss
- 802.11a - Non HT40, One Antenna, 6 to 54 Mbps, 1ss
- 802.11a - Non HT40, Two Antennas, 6 to 54 Mbps, 1ss
- 802.11n/ac - HT/VHT40, One Antenna, M0 to M7, 1ss
- 802.11n/ac - HT/VHT40, Two Antennas, M0 to M7, 1ss
- 802.11n/ac - HT/VHT40, Two Antennas, M8 to M15, 2ss
- 802.11n/ac - HT/VHT40 Beam Forming, Two Antennas, M0 to M7, 1ss
- 802.11n/ac - HT/VHT40 Beam Forming, Two Antennas, M8 to M15, 2ss
- 802.11n/ac - HT/VHT40 STBC, Two Antennas, M0 to M7, 2ss
- 802.11a - Non HT80, One Antenna, 6 to 54 Mbps, 1ss
- 802.11a - Non HT80, Two Antennas, 6 to 54 Mbps, 1ss
- 802.11ac - VHT80, One Antenna, M0 to M9 1ss
- 802.11ac - VHT80, Two Antennas, M0 to M9 1ss
- 802.11ac - VHT80, Two Antennas, M0 to M9 2ss
- 802.11ac - VHT80 Beam Forming, Two Antennas, M0 to M9 1ss
- 802.11ac - VHT80 Beam Forming, Two Antennas, M0 to M9 2ss
- 802.11ac - VHT80 STBC, Two Antennas, M0 to M9 2ss
- 802.11a - Non HT20, One Antenna, 6 to 54 Mbps, 1ss

Model / PID Differences

IW-6300H-AC-x-K9, IW-6300H-DC-x-K9, IW-6300-DCW-x-K9 and ESW-6300-CON-x-K9, all have the same identical components, electronics circuitries, PCB layout and enclosure.

The only differences are listed as below:

IW-6300H-AC-x-K9
IW-6300H-DC-x-K9
IW-6300-DCW-x-K9
ESW-6300-CON-x-K9

Where “x” can be replaced with another letter to indicate country domain.

Domain letters: A, B, C, D, E, F, H, I, L, M, N, Q, R, S, T, Z

Where “AC” is Alternating Current (AC power supply)

Where “DC” is Direct Current (DC power supply), 54V native input

Where “DCW” is Direct Current; wide range 10-36VDC

Where “K9” is encryption software.

The following antennas are supported by this product series.

The data included in this report represent the worst case data for all antennas.

Frequency	Part Number	Antenna Type	Antenna Gain (dBi)	>30 degree 5 GHz Antenna Gain (dBi)
2.4 GHz	AIR-ANT2450V-N	Single Band Omni	5	NA
	AIR-ANT2450V-N-HZ	Single Band Omni, Hazloc	5	NA
	AIR-ANT2480V-N	Single Band Omni	8	NA
	AIR-ANT2450HG-N	Horizontal Polarized Omni	5	NA
	AIR-ANT2450VG-N	Vertical Polarized Omni	5	NA
	AIR-ANT2413P2M-N	Single Band, Dual Polarized Directional Patch	13	NA
5 GHz	AIR-ANT5180V-N	Single Band Omni	8	-3
	AIR-ANT5150HG-N	Horizontal Polarized Omni	5	-5
	AIR-ANT5150VG-N	Vertical Polarized Omni	5	-6
	AIR-ANT5114P2M-N	Single Band, Dual Polarized Directional Patch	13	5
2.4/5 GHz	AIR-ANT2547V-N=	Dual-band Omni	4 / 7	-6
	AIR-ANT2547VG-N=	Dual-band Omni, Gray	4 / 7	-6
	AIR-ANT2547V-N-HZ=	Dual-band Omni, Hazloc	4 / 7	-6
	AIR-ANT2568VG-N	Dual-band Omni	6 / 8	3
	AIR-ANT2588P3M-N=	Dual-band/Dual Polarized Directional, Patch	8 / 8	1
	AIR-ANT2513P4M-N	Dual-band Polarization Diverse Patch Array	13 / 13	-5

Section 3: Result Summary

3.1 Results Summary Table

Conducted emissions

Basic Standard	Technical Requirements / Details	Result
FCC 15.407 RSS-247	6dB Bandwidth: Systems using digital modulation techniques may operate in the 2400-2483.5MHz band. The minimum 6dB bandwidth shall be at least 500 kHz.	Pass
FCC 15.407 RSS-GEN	99% & 26 dB Bandwidth: The 99% occupied bandwidth is the frequency bandwidth such that, below its lower and above its upper frequency limits, the mean powers are each equal to 0.5% of the total mean power of the given emission. There is no limit for 99% OBW. The 26 dB emission is the width of the emission that is constrained by the frequencies associated with the two outermost amplitude points (upper and lower frequencies) that are attenuated by 26 dB relative to the maximum level measured in the fundamental emission.	Pass
FCC 15.407 RSS-247	Output Power: For the band 5.725-5.85 GHz, the maximum conducted output power over the frequency band of operation shall not exceed 1 W.	Pass
FCC 15.407 RSS-247	Power Spectral Density: 15.407 The maximum power spectral density shall not exceed 30 dBm in any 500-kHz band.	Pass
FCC 15.407 RSS-247	Conducted Spurious Emissions / Band-Edge: For transmitters operating in the 5.725-5.85 GHz band: All emissions within the frequency range from the band edge to 10 MHz above or below the band edge shall not exceed an e.i.r.p. of -17 dBm/MHz; for frequencies 10 MHz or greater above or below the band edge, emissions shall not exceed an e.i.r.p. of -27 dBm/MHz.	Pass
FCC 15.209 FCC 152.05 RSS-GEN	Restricted band: Unwanted emissions falling within the restricted bands, as defined in FCC 15.205 (a) must also comply with the radiated emission limits specified in FCC 15.209 (a).	Pass

Radiated Emissions (General requirements)

Basic Standard	Technical Requirements / Details	Result
FCC 15.209 FCC 15.205 RSS-GEN	TX Spurious Emissions: Except as provided elsewhere in this subpart, the emissions from an intentional radiator shall not exceed the field strength levels specified in the filed strength limits table in this section.	Pass
FCC 15.207 RSS-GEN	AC conducted Emissions: Except when the requirements applicable to a given device state otherwise, for any radio apparatus equipped to operate from the public utility AC power supply, either directly or indirectly (such as with a battery charger), the radio frequency voltage of emissions conducted back onto the AC power lines in the frequency range of 0.15 MHz to 30 MHz shall not exceed the limits shown in the table in these sections. The more stringent limit applies at the frequency range boundaries.	Pass

* MPE calculation is recorded in a separate report

Section 4: Sample Details

Note: Each sample was evaluated to ensure that its condition was suitable to be used as a test sample prior to the commencement of testing.

4.1 Sample Details

Sample No.	Equipment Details	Manufacturer	Hardware Rev.	Firmware Rev.	Software Rev.	Serial Number
S01	IW-6300H-DC-B-K9	Cisco Systems, Inc.	11	9.1.8.1	9.0.5.5-W8964	FOC23241G16
S02	FSP150-AWAN3	FSP Group Inc.	-	-	-	H00000063

4.2 System Details

System #	Description	Samples
1	EUT and Power Supply	S01, S02

4.3 Mode of Operation Details

Mode#	Description	Comments
1	Continuous Transmitting	Continuous Transmitting $\geq 98\%$ duty cycle

All measurements were made in accordance with

- ANSI C63.10:2013
- KDB 789033 D02 General UNII Test Procedures New Rules v01r03
- KDB 662911 D01 Multiple Transmitter Output v02r01

Appendix A: Emission Test Results

Conducted Test Setup Diagram

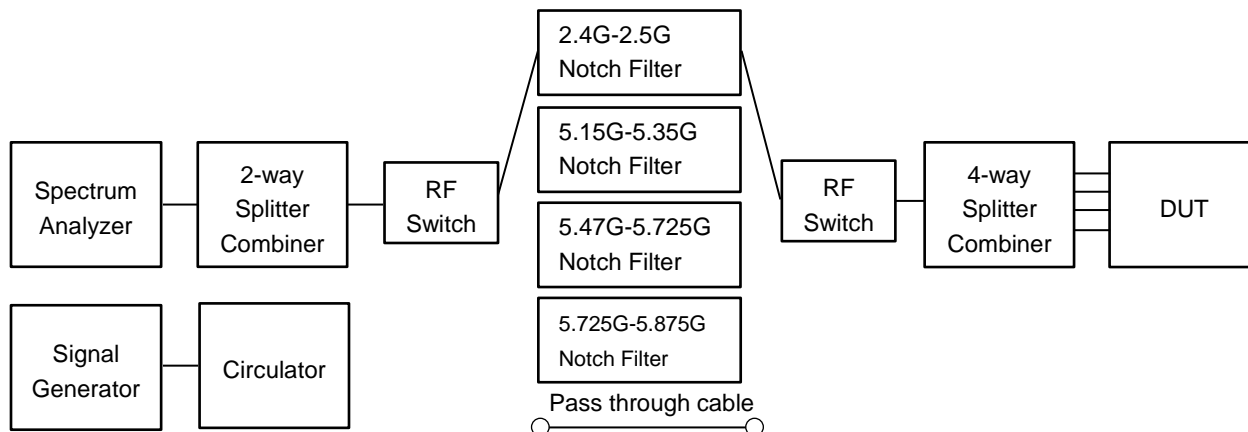

Target Maximum Channel Power

The following table details the maximum supported Total Channel Power for all operating modes.

Operating Mode	Maximum Channel Power (dBm)		
	Frequency (MHz)		
	5745	5785	5825
Non HT20, 6 to 54 Mbps	25	25	24
Non HT20 Beam Forming, 6 to 54 Mbps	21	22	21
HT/VHT20, M0 to M15	25	25	24
HT/VHT20 Beam Forming, M0 to M15	25	25	24
HT/VHT20 STBC, M0 to M7	25	25	24
	5755	5795	
Non HT40, 6 to 54 Mbps	25	24	
HT/VHT40, M0 to M15	26	24	
HT/VHT40 Beam Forming, M0 to M15	26	24	
HT/VHT40 STBC, M0 to M7	26	24	
	5775		
Non HT80, 6 to 54 Mbps	20		
VHT80, M0 to M9, M0 to M9 1-2ss	24		
VHT80 Beam Forming, M0 to M9, M0 to M9 1-2ss	24		
VHT80 STBC, M0 to M9 1ss	24		



A.1 Duty Cycle

Duty Cycle Test Requirement

From KDB 789033 D02 General UNII Test Procedures New Rules v02r01

B. Duty Cycle (x), Transmission Duration (T), and Maximum Power Control Level

1. All measurements are to be performed with the EUT transmitting at 100 percent duty cycle at its maximum power control level; however, if 100 percent duty cycle cannot be achieved, measurements of duty cycle, x, and maximum-power transmission duration, T, are required for each tested mode of operation.

Duty Cycle Test Method

From KDB 789033 D02 General UNII Test Procedures New Rules v02r01:

B. Duty Cycle (x), Transmission Duration (T), and Maximum Power Control Level

The zero-span mode on a spectrum analyzer or EMI receiver, if the response time and spacing between bins on the sweep are sufficient to permit accurate measurements of the on and off times of the transmitted signal. Set the center frequency of the instrument to the center frequency of the transmission. Set RBW \geq EBW if possible; otherwise, set RBW to the largest available value. Set VBW \geq RBW. Set detector = peak or average. The zero-span measurement method shall not be used unless both RBW and VBW are $> 50/T$, where T is defined in section II.B.1.a), and the number of sweep points across duration T exceeds 100. (For example, if VBW and/or RBW are limited to 3 MHz, then the zero-span method of measuring duty cycle shall not be used if $T \leq 16.7$ microseconds.)

Duty Cycle Test Information

Tested By : Julian Land	Date of testing: 04-Oct-19 - 05-Oct-19
Test Result : PASS	

Test Equipment

See Appendix B for list of test equipment

Samples, Systems, and Modes

System Number	Description	Samples	System under test	Support equipment
1	EUT	List Samples here	<input checked="" type="checkbox"/>	<input type="checkbox"/>
	Support	List Samples here	<input type="checkbox"/>	<input checked="" type="checkbox"/>

Duty Cycle Data Table

Duty Cycle table and screen captures are shown below for power/psd modes.

Frequency	Mode	Data Rate	Duty Cycle correction (dB)
5745	Non HT20, 6 to 54 Mbps	6	0.0
	HT/VHT20, M0 to M15	m0	0.0
5755	Non HT40, 6 to 54 Mbps	6	0.0
	HT/VHT40, M0 to M15	m0	0.0

5775	Non HT80, 6 to 54 Mbps	6	0.0
	VHT80, M0 to M9, M0 to M9 1-2ss	m0x1	0.1
5785	Non HT20, 6 to 54 Mbps	6	0.0
	HT/VHT20, M0 to M15	m0	0.0
5795	Non HT40, 6 to 54 Mbps	6	0.0
	HT/VHT40, M0 to M15	m0	0.0
5825	Non HT20, 6 to 54 Mbps	6	0.0
	HT/VHT20, M0 to M15	m0	0.0



Duty Cycle, 5775 MHz, VHT80, M0 to M9, M0 to M9 1-2ss

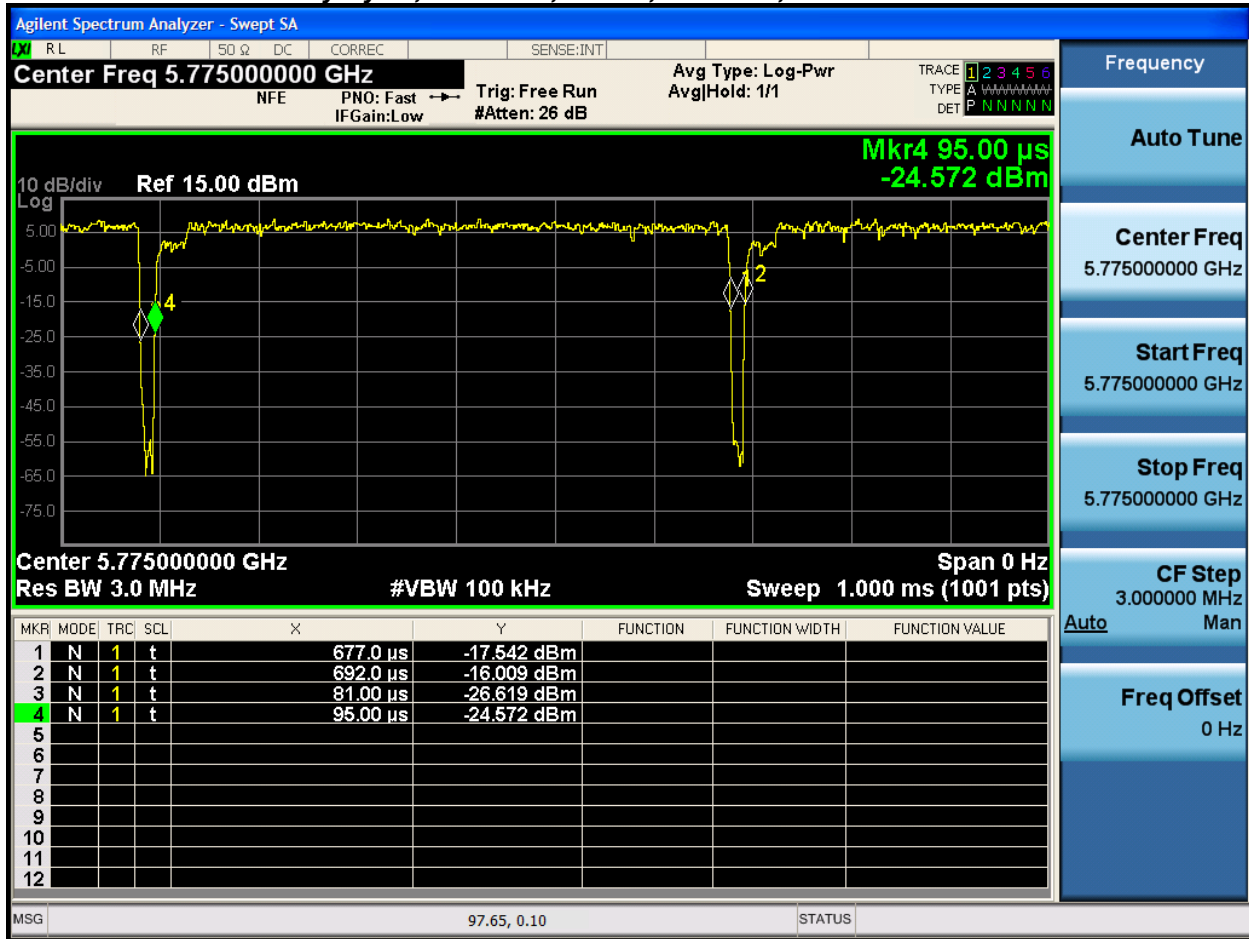

A.2 6dB Bandwidth

15.407 / RSS-247 Within the 5.725-5.85 GHz band, the minimum 6 dB bandwidth of U-NII devices shall be at least 500 kHz.

Test Procedure

Ref. KDB 789033 D02 General UNII Test Procedures New Rules v01r03
ANSI C63.10: 2013

6 BW

Test Procedure

1. Set the radio in the continuous transmitting mode.
2. Allow the trace to stabilize.
3. Setting the x-dB bandwidth mode to -6dB within the measurement set up function.
4. Select the automatic OBW measurement function of an instrument to perform bandwidth measurement.
5. Capture graphs and record pertinent measurement data.

Ref. KDB 789033 D02 General UNII Test Procedures New Rules v01r03
ANSI C63.10: 2013 section 11.8.2 Option 2

6 BW

Test parameters

X dB BW = 6dB (using the OBW function of the spectrum analyzer)
Span = Large enough to capture the entire EBW
RBW = 100 KHz
VBW $\geq 3 \times$ RBW
Sweep = Auto couple
Detector = Peak or where practical sample shall be used
Trace = Max. Hold

System Number	Description	Samples	System under test	Support equipment
1	EUT	S01	<input checked="" type="checkbox"/>	<input type="checkbox"/>
	Support	S02	<input type="checkbox"/>	<input checked="" type="checkbox"/>

Tested By :

Julian Land

Date of testing:

04-Oct-19 - 05-Oct-19

Test Result : PASS

See Appendix B for list of test equipment

6dB Bandwidth Table

Frequency (MHz)	Mode	Data Rate (Mbps)	6dB BW (MHz)	Limit (kHz)	Margin (MHz)
5745	Non HT20, 6 to 54 Mbps	6	16.5	>500	16.00
	HT/VHT20, M0 to M15	m0	17.6	>500	17.10
5755	Non HT40, 6 to 54 Mbps	6	35.8	>500	35.30
	HT/VHT40, M0 to M15	m0	35.7	>500	35.20
5775	Non HT80, 6 to 54 Mbps	6	76.4	>500	75.90
	VHT80, M0 to M9, M0 to M9 1-2ss	m0x1	76.2	>500	75.70
5785	Non HT20, 6 to 54 Mbps	6	16.5	>500	16.00
	HT/VHT20, M0 to M15	m0	17.6	>500	17.10
5795	Non HT40, 6 to 54 Mbps	6	35.8	>500	35.30
	HT/VHT40, M0 to M15	m0	35.6	>500	35.10
5825	Non HT20, 6 to 54 Mbps	6	16.5	>500	16.00
	HT/VHT20, M0 to M15	m0	17.6	>500	17.10

6dB Bandwidth, 5745 MHz, Non HT20, 6 to 54 Mbps

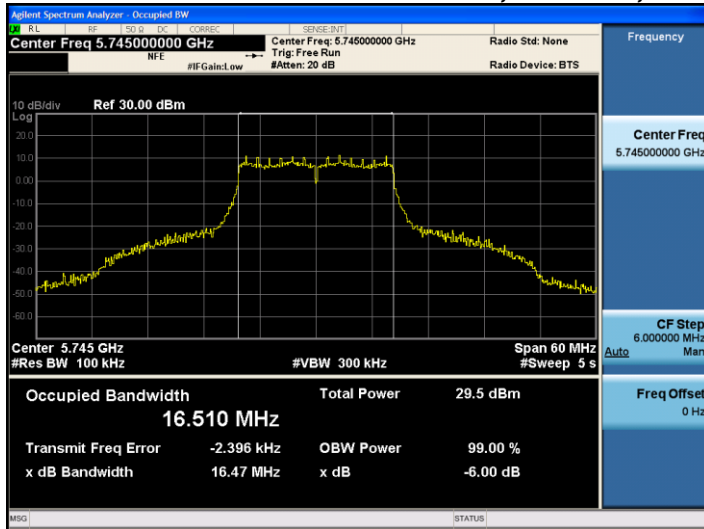

A.3 99% and 26dB Bandwidth

FCC 15.407 / RSS-GEN The 99% occupied bandwidth is the frequency bandwidth such that, below its lower and above its upper frequency limits, the mean powers are each equal to 0.5% of the total mean power of the given emission. There is no limit for 99% OBW.

The 26 dB emission is the width of the emission that is constrained by the frequencies associated with the two outermost amplitude points (upper and lower frequencies) that are attenuated by 26 dB relative to the maximum level measured in the fundamental emission.

Test Procedure

Ref. ANSI C63.10: 2013 Section 6.9.3

99% BW and EBW (-26dB)
Test Procedure
<ol style="list-style-type: none"> 1. Set the radio in the continuous transmitting mode. 2. Allow the trace to stabilize. 3. Setting the x-dB bandwidth mode to -26dB and OBW power function to 99% within the measurement set up function. 4. Select the automatic OBW measurement function of an instrument to perform bandwidth measurement. 5. Capture graphs and record pertinent measurement data.

Ref. ANSI C63.10: 2013 Section 6.9.3

99% BW and EBW (-26dB)
Test parameters
Span = 1.5 x to 5.0 times OBW RBW = approx. 1% to 5% of the OBW VBW ≥ 3 x RBW Detector = Peak or where practical sample shall be used Trace = Max. Hold

System Number	Description	Samples	System under test	Support equipment
1	EUT	S01	<input checked="" type="checkbox"/>	<input type="checkbox"/>
	Support	S02	<input type="checkbox"/>	<input checked="" type="checkbox"/>

Tested By : Julian Land	Date of testing: 04-Oct-19 - 05-Oct-19
Test Result : PASS	

See Appendix B for list of test equipment

99% and 26dB Bandwidth Table

Frequency (MHz)	Mode	Data Rate (Mbps)	26dB BW (MHz)	99% BW (MHz)
5745	Non HT20, 6 to 54 Mbps	6	19.8	16.619
	HT/VHT20, M0 to M15	m0	20.3	17.660
5755	Non HT40, 6 to 54 Mbps	6	52.4	36.589
	HT/VHT40, M0 to M15	m0	40.8	36.205
5775	Non HT80, 6 to 54 Mbps	6	82.0	76.377
	VHT80, M0 to M9, M0 to M9 1-2ss	m0x1	82.4	76.430
5785	Non HT20, 6 to 54 Mbps	6	19.6	16.607
	HT/VHT20, M0 to M15	m0	20.1	17.645
5795	Non HT40, 6 to 54 Mbps	6	43.3	36.483
	HT/VHT40, M0 to M15	m0	40.5	36.201
5825	Non HT20, 6 to 54 Mbps	6	19.6	16.605
	HT/VHT20, M0 to M15	m0	20.2	17.650

26dB / 99% Bandwidth, 5825 MHz, Non HT20 Beam Forming, 6 to 54 Mbps

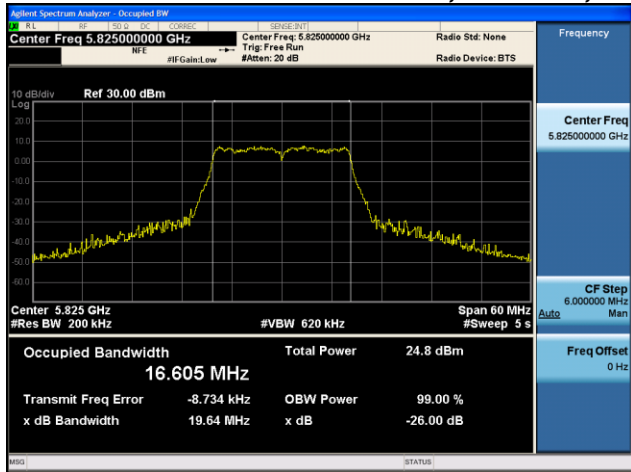

A.4 Maximum Conducted Output Power

15.407 / RSS-247 For the band 5.725-5.85 GHz, the maximum conducted output power over the frequency band of operation shall not exceed 1 W. If transmitting antennas of directional gain greater than 6 dBi are used, both the maximum conducted output power and the maximum power spectral density shall be reduced by the amount in dB that the directional gain of the antenna exceeds 6 dBi. However, fixed point-to-point U-NII devices operating in this band may employ transmitting antennas with directional gain greater than 6 dBi without any corresponding reduction in transmitter conducted power. Fixed, point-to-point operations exclude the use of point-to-multipoint systems, omnidirectional applications, and multiple collocated transmitters transmitting the same information. The operator of the U-NII device, or if the equipment is professionally installed, the installer, is responsible for ensuring that systems employing high gain directional antennas are used exclusively for fixed, point-to-point operations.

The peak correlated gain for each mode is listed in the table below. See the Theory of Operation for details on the correlated gain for each mode.

Test Procedure

Ref. KDB 789033 D02 General UNII Test Procedures New Rules v01r03
ANSI C63.10: 2013

Output Power Test Procedure
<ol style="list-style-type: none"> 1. Set the radio in the continuous transmitting mode at full power 2. Compute power by integrating the spectrum across the EBW (or alternatively entire 99% OBW) of the signal using the instrument's band power measurement function. The integration shall be performed using the spectrum analyzer band-power measurement function with band limits set equal to the EBW or the OBW band edges. 3. Capture graphs and record pertinent measurement data.

Ref. KDB 789033 D02 General UNII Test Procedures New Rules v01r03
ANSI C63.10: 2013 section 12.3.2.2 Method SA-1

Output Power Test parameters
Span = >1.5 times the OBW RBW = 1MHz VBW ≥ 3 x RBW Sweep = Auto couple Detector = sample Trace = Trace Average 100

The "measure-and-sum technique" is used for measuring in-band transmit power of a device. In the measure-and-sum approach, the conducted emission level is measured at each antenna port. The measured results at the various antenna ports are then summed mathematically to determine the total emission level from the device. Summing is performed in linear power units. (See ANSI C63.10 section 14.3.2.2)

System Number	Description	Samples	System under test	Support equipment
1	EUT	S01	<input checked="" type="checkbox"/>	<input type="checkbox"/>
	Support	S02	<input type="checkbox"/>	<input checked="" type="checkbox"/>

Tested By : Julian Land	Date of testing: 04-Oct-19 - 05-Oct-19
Test Result : PASS	

See Appendix B for list of test equipment

Maximum Output Power

Frequency (MHz)	Mode	Tx Paths	Correlated Antenna Gain (dBi)	Tx 1 Max Power (dBm)	Tx 2 Max Power (dBm)	Duty Cycle Correction (dB)	Total Tx Channel Power (dBm)	Limit (dBm)	Margin (dB)
5745	Non HT20, 6 to 54 Mbps	1	7	22.1		0.0	22.1	29.0	6.88
	Non HT20, 6 to 54 Mbps	2	7	22.1	22.0	0.0	25.1	29.0	3.91
	Non HT20 Beam Forming, 6 to 54 Mbps	2	10	17.8	17.3	0.0	20.6	26.0	5.41
	HT/VHT20, M0 to M7	1	7	22.3		0.0	22.3	29.0	6.67
	HT/VHT20, M0 to M7	2	7	22.3	22.4	0.0	25.4	29.0	3.61
	HT/VHT20, M8 to M15	2	7	22.3	22.4	0.0	25.4	29.0	3.61
	HT/VHT20 Beam Forming, M0 to M7	2	10	18.1	17.6	0.0	20.9	26.0	5.11
	HT/VHT20 Beam Forming, M8 to M15	2	7	22.3	22.4	0.0	25.4	29.0	3.61
	HT/VHT20 STBC, M0 to M7	2	7	22.3	22.4	0.0	25.4	29.0	3.61
5755	Non HT40, 6 to 54 Mbps	1	7	21.6		0.0	21.6	29.0	7.37
	Non HT40, 6 to 54 Mbps	2	7	21.6	21.5	0.0	24.6	29.0	4.41
	HT/VHT40, M0 to M7	1	7	22.7		0.0	22.7	29.0	6.26
	HT/VHT40, M0 to M7	2	7	22.7	22.6	0.0	25.7	29.0	3.30
	HT/VHT40, M8 to M15	2	7	22.7	22.6	0.0	25.7	29.0	3.30
	HT/VHT40 Beam Forming, M0 to M7	2	10	18.5	18.2	0.0	21.4	26.0	4.59
	HT/VHT40 Beam Forming, M8 to M15	2	7	22.7	22.6	0.0	25.7	29.0	3.30
	HT/VHT40 STBC, M0 to M7	2	7	22.7	22.6	0.0	25.7	29.0	3.30
5775	Non HT80, 6 to 54 Mbps	1	7	17.2		0.0	17.2	29.0	11.78
	Non HT80, 6 to 54 Mbps	2	7	17.2	17.2	0.0	20.2	29.0	8.77
	VHT80, M0 to M9 1ss	1	7	23.1		0.1	23.2	29.0	5.80
	VHT80, M0 to M9 1ss	2	7	21.2	21.1	0.1	24.3	29.0	4.74
	VHT80, M0 to M9 2ss	2	7	21.2	21.1	0.1	24.3	29.0	4.74
	VHT80 Beam Forming, M0 to M9 1ss	2	10	19.1	19.0	0.1	22.2	26.0	3.84
	VHT80 Beam Forming, M0 to M9 2ss	2	7	21.2	21.1	0.1	24.3	29.0	4.74
	VHT80 STBC, M0 to M9 1ss	2	7	21.2	21.1	0.1	24.3	29.0	4.74

5785	Non HT20, 6 to 54 Mbps	1	7	23.4		0.0	23.4	29.0	5.58
	Non HT20, 6 to 54 Mbps	2	7	22.5	21.7	0.0	25.2	29.0	3.85
	Non HT20 Beam Forming, 6 to 54 Mbps	2	10	19.4	18.5	0.0	22.0	26.0	3.99
	HT/VHT20, M0 to M7	1	7	23.6		0.0	23.6	29.0	5.37
	HT/VHT20, M0 to M7	2	7	22.7	22.0	0.0	25.4	29.0	3.60
	HT/VHT20, M8 to M15	2	7	22.7	22.0	0.0	25.4	29.0	3.60
	HT/VHT20 Beam Forming, M0 to M7	2	10	19.6	18.7	0.0	22.2	26.0	3.79
	HT/VHT20 Beam Forming, M8 to M15	2	7	22.7	22.0	0.0	25.4	29.0	3.60
	HT/VHT20 STBC, M0 to M7	2	7	22.7	22.0	0.0	25.4	29.0	3.60
5795	Non HT40, 6 to 54 Mbps	1	7	20.9		0.0	20.9	29.0	8.07
	Non HT40, 6 to 54 Mbps	2	7	20.9	20.4	0.0	23.7	29.0	5.31
	HT/VHT40, M0 to M7	1	7	22.7		0.0	22.7	29.0	6.26
	HT/VHT40, M0 to M7	2	7	20.9	20.3	0.0	23.7	29.0	5.34
	HT/VHT40, M8 to M15	2	7	20.9	20.3	0.0	23.7	29.0	5.34
	HT/VHT40 Beam Forming, M0 to M7	2	10	18.0	17.5	0.0	20.8	26.0	5.19
	HT/VHT40 Beam Forming, M8 to M15	2	7	20.9	20.3	0.0	23.7	29.0	5.34
	HT/VHT40 STBC, M0 to M7	2	7	20.9	20.3	0.0	23.7	29.0	5.34
5825	Non HT20, 6 to 54 Mbps	1	7	21.9		0.0	21.9	29.0	7.08
	Non HT20, 6 to 54 Mbps	2	7	21.9	20.8	0.0	24.4	29.0	4.58
	Non HT20 Beam Forming, 6 to 54 Mbps	2	10	18.2	17.2	0.0	20.8	26.0	5.24
	HT/VHT20, M0 to M7	1	7	22.0		0.0	22.0	29.0	6.97
	HT/VHT20, M0 to M7	2	7	21.2	20.1	0.0	23.7	29.0	5.28
	HT/VHT20, M8 to M15	2	7	21.2	20.1	0.0	23.7	29.0	5.28
	HT/VHT20 Beam Forming, M0 to M7	2	10	18.3	17.4	0.0	20.9	26.0	5.09
	HT/VHT20 Beam Forming, M8 to M15	2	7	21.2	20.1	0.0	23.7	29.0	5.28
	HT/VHT20 STBC, M0 to M7	2	7	21.2	20.1	0.0	23.7	29.0	5.28

Maximum Transmit Output Power, 5755 MHz, HT/VHT40, M0 to M7

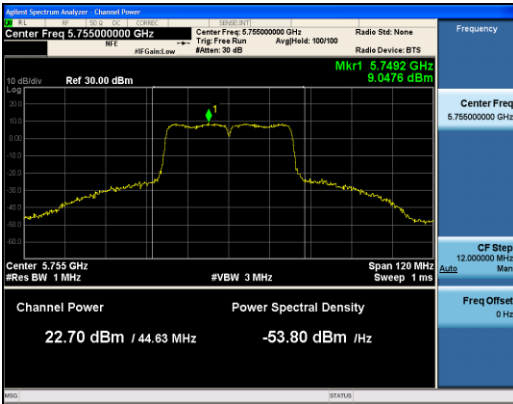

Antenna A

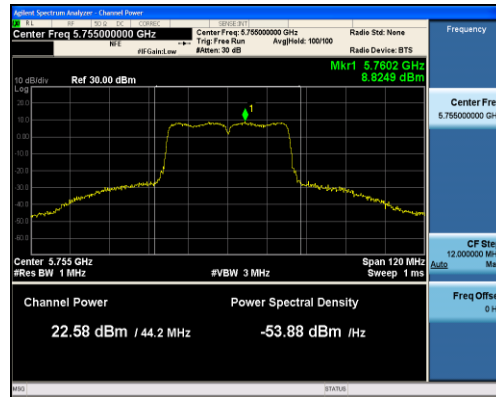

Antenna B

A.5 Power Spectral Density

15.407 / RSS-247 The power spectral density shall not exceed 30 dBm in any 500 kHz band. If transmitting antennas of directional gain greater than 6 dBi are used, both the maximum conducted output power and the power spectral density shall be reduced by the amount in dB that the directional gain of the antenna exceeds 6 dBi.

Test Procedure

Ref. KDB 789033 D02 General UNII Test Procedures New Rules v01

Power Spectral Density Test Procedure
1. Connect the antenna port(s) to the spectrum analyzer input. 2. Set the radio in the continuous transmitting mode at full power 3. Configure Spectrum analyzer as per test parameters below and Peak search marker 4. Capture graphs and record pertinent measurement data.

Ref. KDB 789033 D02 v01 section F.5

Power Spectral Density Test parameters
Span = >1.5 times the OBW RBW = 500 kHz. VBW ≥ 3 x RBW Sweep = 10s Detector = Peak Trace = Single Sweep Marker = Peak Search

The “Measure and add 10 log(N) dB technique”, where N is the number of outputs, is used for measuring in-band Power Spectral Density. With this technique, spectrum measurements are performed at each output of the device, and the quantity 10 log(4) (or 6dB) is added to the worst case spectrum value before comparing to the emission limit. (ANSI C63.10 2013 section 14.3.2.3)

System Number	Description	Samples	System under test	Support equipment
1	EUT	S01	<input checked="" type="checkbox"/>	<input type="checkbox"/>
	Support	S02	<input type="checkbox"/>	<input checked="" type="checkbox"/>

Tested By : Julian Land	Date of testing: 04-Oct-19 - 05-Oct-19
Test Result : PASS	

See Appendix B for list of test equipment

Power Spectral Density

Frequency (MHz)	Mode	Tx Paths		Correlated Antenna Gain (dBi)	Tx 1 PSD (dBm/500kHz)	Tx 2 PSD (dBm/500kHz)	Duty Cycle Correction (dB)	Total PSD (dBm/500kHz)	Limit (dBm/500kHz)	Margin (dB)
5745	Non HT20, 6 to 54 Mbps	1	7		8.3		0.0	8.3	29.0	20.68
	Non HT20, 6 to 54 Mbps	2	10		8.3	8.5	0.0	11.4	26.0	14.56
	Non HT20 Beam Forming, 6 to 54 Mbps	2	10		4.0	3.7	0.0	6.9	26.0	19.11
	HT/VHT20, M0 to M7	1	7		8.2		0.0	8.2	29.0	20.77
	HT/VHT20, M0 to M7	2	10		8.2	8.3	0.0	11.3	26.0	14.71
	HT/VHT20, M8 to M15	2	7		8.2	8.3	0.0	11.3	29.0	17.71
	HT/VHT20 Beam Forming, M0 to M7	2	10		3.9	4.1	0.0	7.0	26.0	18.96
	HT/VHT20 Beam Forming, M8 to M15	2	7		8.2	8.3	0.0	11.3	29.0	17.71
HT/VHT20 STBC, M0 to M7	2	7		8.2	8.3	0.0	11.3	29.0	17.71	
5755	Non HT40, 6 to 54 Mbps	1	7		5.0		0.0	5.0	29.0	23.97
	Non HT40, 6 to 54 Mbps	2	10		5.0	5.0	0.0	8.0	26.0	17.96
	HT/VHT40, M0 to M7	1	7		5.4		0.0	5.4	29.0	23.56
	HT/VHT40, M0 to M7	2	10		5.4	5.5	0.0	8.5	26.0	17.50
	HT/VHT40, M8 to M15	2	7		5.4	5.5	0.0	8.5	29.0	20.50
	HT/VHT40 Beam Forming, M0 to M7	2	10		1.4	1.0	0.0	4.3	26.0	21.74
	HT/VHT40 Beam Forming, M8 to M15	2	7		5.4	5.5	0.0	8.5	29.0	20.50
	HT/VHT40 STBC, M0 to M7	2	7		5.4	5.5	0.0	8.5	29.0	20.50
5775	Non HT80, 6 to 54 Mbps	1	7		-3.3		0.0	-3.3	29.0	32.28
	Non HT80, 6 to 54 Mbps	2	10		-3.3	-3.0	0.0	-0.1	26.0	26.12
	VHT80, M0 to M9 1ss	1	7		2.3		0.1	2.4	29.0	26.60
	VHT80, M0 to M9 1ss	2	10		0.3	0.5	0.1	3.5	26.0	22.49
	VHT80, M0 to M9 2ss	2	7		0.3	0.5	0.1	3.5	29.0	25.49
	VHT80 Beam Forming, M0 to M9 1ss	2	10		-1.8	-2.1	0.1	1.2	26.0	24.83
	VHT80 Beam Forming, M0 to M9 2ss	2	7		0.3	0.5	0.1	3.5	29.0	25.49
	VHT80 STBC, M0 to M9 1ss	2	7		0.3	0.5	0.1	3.5	29.0	25.49

5785	Non HT20, 6 to 54 Mbps	1	7	9.8		0.0	9.8	29.0	19.18
	Non HT20, 6 to 54 Mbps	2	10	9.0	7.8	0.0	11.5	26.0	14.52
	Non HT20 Beam Forming, 6 to 54 Mbps	2	10	5.5	4.9	0.0	8.2	26.0	17.75
	HT/VHT20, M0 to M7	1	7	9.6		0.0	9.6	29.0	19.37
	HT/VHT20, M0 to M7	2	10	8.6	7.9	0.0	11.3	26.0	14.70
	HT/VHT20, M8 to M15	2	7	8.6	7.9	0.0	11.3	29.0	17.70
	HT/VHT20 Beam Forming, M0 to M7	2	10	5.5	4.7	0.0	8.2	26.0	17.84
	HT/VHT20 Beam Forming, M8 to M15	2	7	8.6	7.9	0.0	11.3	29.0	17.70
	HT/VHT20 STBC, M0 to M7	2	7	8.6	7.9	0.0	11.3	29.0	17.70
5795	Non HT40, 6 to 54 Mbps	1	7	4.2		0.0	4.2	29.0	24.77
	Non HT40, 6 to 54 Mbps	2	10	4.2	3.7	0.0	7.0	26.0	19.01
	HT/VHT40, M0 to M7	1	7	5.4		0.0	5.4	29.0	23.56
	HT/VHT40, M0 to M7	2	10	3.9	3.2	0.0	6.6	26.0	19.38
	HT/VHT40, M8 to M15	2	7	3.9	3.2	0.0	6.6	29.0	22.38
	HT/VHT40 Beam Forming, M0 to M7	2	10	1.1	0.6	0.0	3.9	26.0	22.09
	HT/VHT40 Beam Forming, M8 to M15	2	7	3.9	3.2	0.0	6.6	29.0	22.38
	HT/VHT40 STBC, M0 to M7	2	7	3.9	3.2	0.0	6.6	29.0	22.38
5825	Non HT20, 6 to 54 Mbps	1	7	8.0		0.0	8.0	29.0	20.98
	Non HT20, 6 to 54 Mbps	2	10	8.0	6.9	0.0	10.5	26.0	15.48
	Non HT20 Beam Forming, 6 to 54 Mbps	2	10	4.4	3.4	0.0	7.0	26.0	19.04
	HT/VHT20, M0 to M7	1	7	8.0		0.0	8.0	29.0	20.97
	HT/VHT20, M0 to M7	2	10	7.7	5.9	0.0	9.9	26.0	16.07
	HT/VHT20, M8 to M15	2	7	7.7	5.9	0.0	9.9	29.0	19.07
	HT/VHT20 Beam Forming, M0 to M7	2	10	4.5	3.4	0.0	7.0	26.0	18.98
	HT/VHT20 Beam Forming, M8 to M15	2	7	7.7	5.9	0.0	9.9	29.0	19.07
	HT/VHT20 STBC, M0 to M7	2	7	7.7	5.9	0.0	9.9	29.0	19.07

Power Spectral Density, 5785 MHz, Non HT20, 6 to 54 Mbps

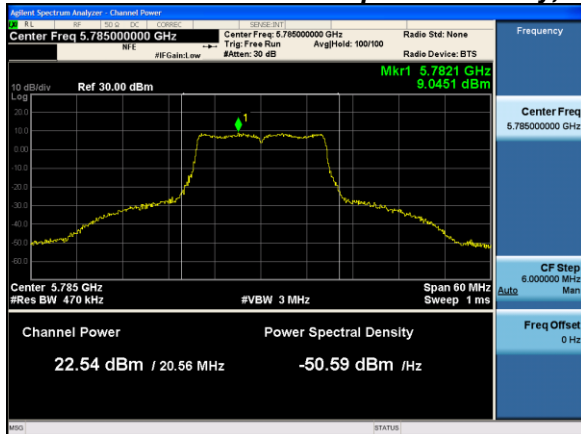

Antenna A

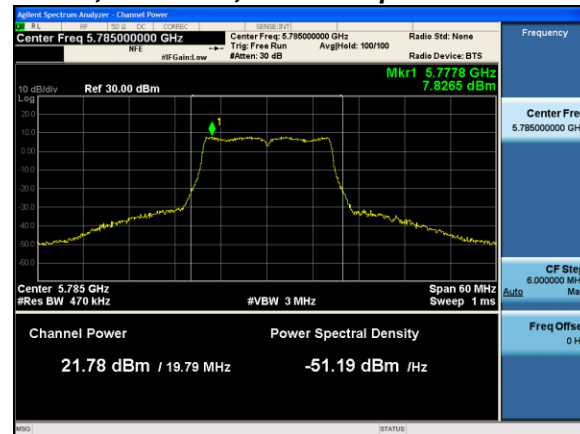

Antenna B

A.6 Conducted Spurious Emissions

15.205 / 15.209 / LP0002 - Radiated emissions which fall in the restricted bands, as defined in Section 15.205(a), must also comply with the radiated emission limits specified in Section 15.209(a) (see Section 15.205(c)).

RSS-Gen 8.9: Except when the requirements applicable to a given device state otherwise, emissions from licence-exempt transmitters shall comply with the field strength limits shown in Table 4 and Table 5 below. Additionally, the level of any transmitter emission shall not exceed the level of the transmitter's fundamental emission.

RSS-Gen 8.10 (b) Unwanted emissions that fall into restricted bands of Table 6 shall comply with the limits specified in RSS-Gen; and **(c)** Unwanted emissions that do not fall within the restricted frequency bands of Table 6 shall comply either with the limits specified in the applicable RSS or with those specified in this RSS-Gen.

Use formula below to substitute conducted measurements in place of radiated measurements

$$E[\text{dB}\mu\text{V}/\text{m}] = \text{EIRP}[\text{dBm}] - 20 \log(d[\text{meters}]) + 104.77, \text{ where } E = \text{field strength and } d = 3 \text{ meter}$$

- 1) Average Plot, Limit= -41.25 dBm eirp
- 2) Peak plot, Limit = -21.25 dBm eirp

Test Procedure

Ref. KDB 789033 D02 General UNII Test Procedures New Rules v01r03
ANSI C63.10: 2013

Conducted Spurious Emissions

Test Procedure

1. Connect the antenna port(s) to the spectrum analyzer input.
2. Place the radio in continuous transmit mode. Use the procedures in KDB 789033 D02 General UNII Test Procedures New Rules v01r03 to substitute conducted measurements in place of radiated measurements.
3. Configure Spectrum analyzer as per test parameters below (be sure to enter all losses between the transmitter output and the spectrum analyzer).
4. Record the marker waveform peak to spur difference. Also measure any emissions in the restricted bands.
5. The "measure-and-sum technique" is used for measuring in-band transmit power of a device. In the measure-and-sum approach, the conducted emission level is measured at each antenna port. The measured results at the various antenna ports are then summed mathematically to determine the total emission level from the device. Summing is performed in linear power units. The worst case output is recorded.
6. Capture graphs and record pertinent measurement data.

Ref. KDB 789033 D02 General UNII Test Procedures New Rules v01r03
ANSI C63.10: 2013 section 12.7.7.3 (average) & 12.7.6 (peak)

Conducted Spurious Emissions

Test parameters

Span = 30MHz to 18GHz / 18GHz to 40GHz
 RBW = 1 MHz
 VBW ≥ 3 x RBW for Peak, 1kHz for Average
 Sweep = Auto couple
 Detector = Peak
 Trace = Max Hold.

System Number	Description	Samples	System under test	Support equipment
1	EUT	S01	<input checked="" type="checkbox"/>	<input type="checkbox"/>
	Support	S02	<input type="checkbox"/>	<input checked="" type="checkbox"/>

Tested By : Julian Land	Date of testing: 04-Oct-19 - 05-Oct-19
Test Result : PASS	

See Appendix B for list of test equipment



Conducted Spurs Average, All Antennas



Conducted Spurs Peak, All Antennas

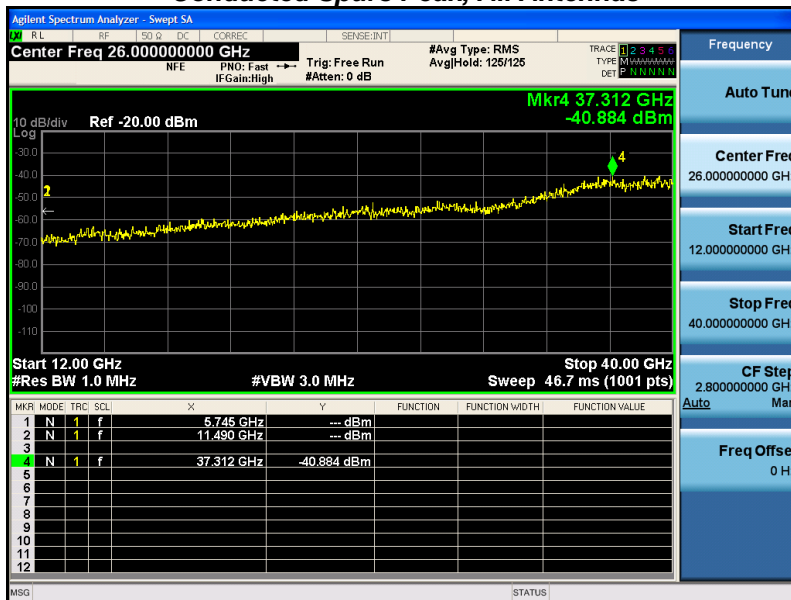

Conducted Spurious Average Table

Frequency (MHz)	Mode	Tx Paths	Correlated Antenna Gain (dBi)	Tx 1 Spur Power (dBm)	Tx 2 Spur Power (dBm)	Duty Cycle Correction (dB)	Total Conducted Spur (dBm)	Limit (dBm)	Margin (dB)
5745	Non HT20, 6 to 54 Mbps	1	7	-51.9		0.0	-44.9	-41.25	3.63
	Non HT20, 6 to 54 Mbps	2	7	-51.9	-52.1	0.0	-42.0	-41.25	0.71
	Non HT20 Beam Forming, 6 to 54 Mbps	2	10	-56.0	-56.1	0.0	-43.0	-41.25	1.76
	HT/VHT20, M0 to M7	1	7	-51.7		0.0	-44.7	-41.25	3.42
	HT/VHT20, M0 to M7	2	7	-51.7	-51.9	0.0	-41.8	-41.25	0.51
	HT/VHT20, M8 to M15	2	7	-51.7	-51.9	0.0	-41.8	-41.25	0.51
	HT/VHT20 Beam Forming, M0 to M7	2	10	-55.9	-56.0	0.0	-42.9	-41.25	1.66
	HT/VHT20 Beam Forming, M8 to M15	2	7	-51.7	-51.9	0.0	-41.8	-41.25	0.51
	HT/VHT20 STBC, M0 to M7	2	7	-51.7	-51.9	0.0	-41.8	-41.25	0.51
5755	Non HT40, 6 to 54 Mbps	1	7	-51.6		0.0	-44.6	-41.25	3.32
	Non HT40, 6 to 54 Mbps	2	7	-51.6	-51.9	0.0	-41.7	-41.25	0.46
	HT/VHT40, M0 to M7	1	7	-51.4		0.0	-44.4	-41.25	3.11
	HT/VHT40, M0 to M7	2	7	-51.4	-51.6	0.0	-41.4	-41.25	0.20
	HT/VHT40, M8 to M15	2	7	-51.4	-51.6	0.0	-41.4	-41.25	0.20
	HT/VHT40 Beam Forming, M0 to M7	2	10	-55.4	-55.5	0.0	-42.4	-41.25	1.15
	HT/VHT40 Beam Forming, M8 to M15	2	7	-51.4	-51.6	0.0	-41.4	-41.25	0.20
	HT/VHT40 STBC, M0 to M7	2	7	-51.4	-51.6	0.0	-41.4	-41.25	0.20
5775	Non HT80, 6 to 54 Mbps	1	7	-52.3		0.0	-45.3	-41.25	4.03
	Non HT80, 6 to 54 Mbps	2	7	-52.3	-52.1	0.0	-42.2	-41.25	0.92
	VHT80, M0 to M9 1ss	1	7	-50.9		0.1	-43.8	-41.25	2.55
	VHT80, M0 to M9 1ss	2	7	-51.5	-51.7	0.1	-41.5	-41.25	0.24
	VHT80, M0 to M9 2ss	2	7	-51.5	-51.7	0.1	-41.5	-41.25	0.24
	VHT80 Beam Forming, M0 to M9 1ss	2	10	-55.1	-55.4	0.1	-42.1	-41.25	0.88
	VHT80 Beam Forming, M0 to M9 2ss	2	7	-51.5	-51.7	0.1	-41.5	-41.25	0.24
	VHT80 STBC, M0 to M9 1ss	2	7	-51.5	-51.7	0.1	-41.5	-41.25	0.24
5785	Non HT20, 6 to 54 Mbps	1	7	-51.0		0.0	-44.0	-41.25	2.73
	Non HT20, 6 to 54 Mbps	2	7	-51.3	-51.4	0.0	-41.3	-41.25	0.06
	Non HT20 Beam Forming, 6 to 54 Mbps	2	10	-54.9	-55.6	0.0	-42.2	-41.25	0.95
	HT/VHT20, M0 to M7	1	7	-50.9		0.0	-43.9	-41.25	2.62



	HT/VHT20, M0 to M7	2	7	-51.3	-51.5	0.0	-41.4	-41.25	0.11
	HT/VHT20, M8 to M15	2	7	-51.3	-51.5	0.0	-41.4	-41.25	0.11
	HT/VHT20 Beam Forming, M0 to M7	2	10	-54.8	-55.3	0.0	-42.0	-41.25	0.76
	HT/VHT20 Beam Forming, M8 to M15	2	7	-51.3	-51.5	0.0	-41.4	-41.25	0.11
	HT/VHT20 STBC, M0 to M7	2	7	-51.3	-51.5	0.0	-41.4	-41.25	0.11
5795	Non HT40, 6 to 54 Mbps	1	7	-51.4		0.0	-44.4	-41.25	3.12
	Non HT40, 6 to 54 Mbps	2	7	-51.4	-51.6	0.0	-41.5	-41.25	0.21
	HT/VHT40, M0 to M7	1	7	-50.9		0.0	-43.9	-41.25	2.61
	HT/VHT40, M0 to M7	2	7	-51.3	-51.7	0.0	-41.4	-41.25	0.19
	HT/VHT40, M8 to M15	2	7	-51.3	-51.7	0.0	-41.4	-41.25	0.19
	HT/VHT40 Beam Forming, M0 to M7	2	10	-55.1	-55.6	0.0	-42.3	-41.25	1.04
	HT/VHT40 Beam Forming, M8 to M15	2	7	-51.3	-51.7	0.0	-41.4	-41.25	0.19
	HT/VHT40 STBC, M0 to M7	2	7	-51.3	-51.7	0.0	-41.4	-41.25	0.19
5825	Non HT20, 6 to 54 Mbps	1	7	-51.1		0.0	-44.1	-41.25	2.83
	Non HT20, 6 to 54 Mbps	2	7	-51.1	-51.8	0.0	-41.4	-41.25	0.15
	Non HT20 Beam Forming, 6 to 54 Mbps	2	10	-54.8	-55.8	0.0	-42.2	-41.25	0.99
	HT/VHT20, M0 to M7	1	7	-50.9		0.0	-43.9	-41.25	2.62
	HT/VHT20, M0 to M7	2	7	-51.3	-51.7	0.0	-41.5	-41.25	0.21
	HT/VHT20, M8 to M15	2	7	-51.3	-51.7	0.0	-41.5	-41.25	0.21
	HT/VHT20 Beam Forming, M0 to M7	2	10	-54.7	-55.6	0.0	-42.1	-41.25	0.84
	HT/VHT20 Beam Forming, M8 to M15	2	7	-51.3	-51.7	0.0	-41.5	-41.25	0.21
	HT/VHT20 STBC, M0 to M7	2	7	-51.3	-51.7	0.0	-41.5	-41.25	0.21



Conducted Spurs Average, 5785 MHz, Non HT20, 6 to 54 Mbps

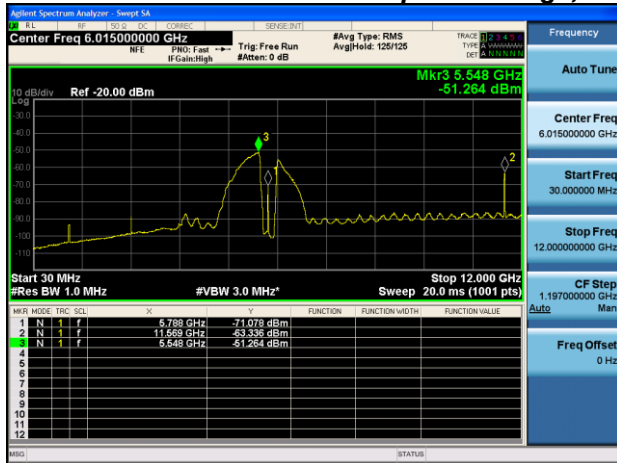

Antenna A

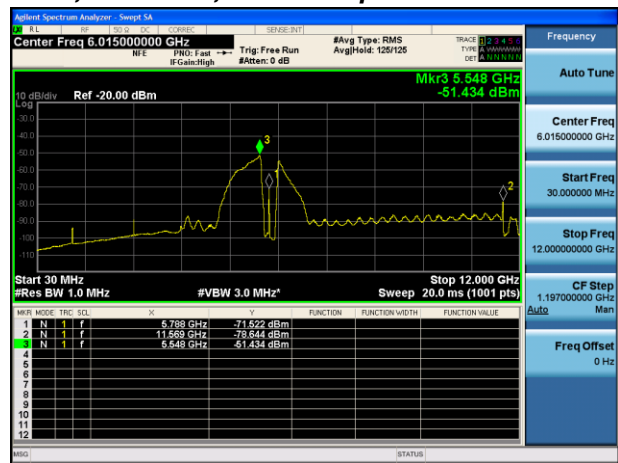

Antenna B

Conducted Spurious Peak

Frequency (MHz)	Mode	Tx Paths	Correlated Antenna Gain (dBi)	Tx 1 Spur Power (dBm)	Tx 2 Spur Power (dBm)	Duty Cycle Correction (dB)	Total Conducted Spur (dBm)	Limit (dBm)	Margin (dB)
5745	Non HT20, 6 to 54 Mbps	1	7	-41.1		0.0	-34.1	-21.25	12.83
	Non HT20, 6 to 54 Mbps	2	7	-41.1	-43.5	0.0	-32.1	-21.25	10.85
	Non HT20 Beam Forming, 6 to 54 Mbps	2	10	-46.1	-47.9	0.0	-33.9	-21.25	12.62
	HT/VHT20, M0 to M7	1	7	-41.6		0.0	-34.6	-21.25	13.32
	HT/VHT20, M0 to M7	2	7	-41.6	-42.9	0.0	-32.2	-21.25	10.91
	HT/VHT20, M8 to M15	2	7	-41.6	-42.9	0.0	-32.2	-21.25	10.91
	HT/VHT20 Beam Forming, M0 to M7	2	10	-44.8	-47.8	0.0	-33.0	-21.25	11.76
	HT/VHT20 Beam Forming, M8 to M15	2	7	-41.6	-42.9	0.0	-32.2	-21.25	10.91
HT/VHT20 STBC, M0 to M7	2	7	-41.6	-42.9	0.0	-32.2	-21.25	10.91	
5755	Non HT40, 6 to 54 Mbps	1	7	-42.2		0.0	-35.2	-21.25	13.92
	Non HT40, 6 to 54 Mbps	2	7	-42.2	-43.5	0.0	-32.8	-21.25	11.52
	HT/VHT40, M0 to M7	1	7	-42.6		0.0	-35.6	-21.25	14.31
	HT/VHT40, M0 to M7	2	7	-42.6	-42.5	0.0	-32.5	-21.25	11.25
	HT/VHT40, M8 to M15	2	7	-42.6	-42.5	0.0	-32.5	-21.25	11.25
	HT/VHT40 Beam Forming, M0 to M7	2	10	-46.3	-47.6	0.0	-33.8	-21.25	12.60
	HT/VHT40 Beam Forming, M8 to M15	2	7	-42.6	-42.5	0.0	-32.5	-21.25	11.25
	HT/VHT40 STBC, M0 to M7	2	7	-42.6	-42.5	0.0	-32.5	-21.25	11.25
5775	Non HT80, 6 to 54 Mbps	1	7	-43.8		0.0	-36.8	-21.25	15.53
	Non HT80, 6 to 54 Mbps	2	7	-43.8	-45.7	0.0	-34.6	-21.25	13.37
	VHT80, M0 to M9 1ss	1	7	-41.9		0.1	-34.8	-21.25	13.55
	VHT80, M0 to M9 1ss	2	7	-41.7	-42.4	0.1	-31.9	-21.25	10.67
	VHT80, M0 to M9 2ss	2	7	-41.7	-42.4	0.1	-31.9	-21.25	10.67
	VHT80 Beam Forming, M0 to M9 1ss	2	10	-45.8	-47.4	0.1	-33.4	-21.25	12.16
	VHT80 Beam Forming, M0 to M9 2ss	2	7	-41.7	-42.4	0.1	-31.9	-21.25	10.67
	VHT80 STBC, M0 to M9 1ss	2	7	-41.7	-42.4	0.1	-31.9	-21.25	10.67
5785	Non HT20, 6 to 54 Mbps	1	7	-42.1		0.0	-35.1	-21.25	13.83
	Non HT20, 6 to 54 Mbps	2	7	-42.4	-43.2	0.0	-32.7	-21.25	11.50

	Non HT20 Beam Forming, 6 to 54 Mbps	2	10	-44.8	-47.8	0.0	-33.0	-21.25	11.76
	HT/VHT20, M0 to M7	1	7	-42.1		0.0	-35.1	-21.25	13.82
	HT/VHT20, M0 to M7	2	7	-42.1	-42.8	0.0	-32.4	-21.25	11.15
	HT/VHT20, M8 to M15	2	7	-42.1	-42.8	0.0	-32.4	-21.25	11.15
	HT/VHT20 Beam Forming, M0 to M7	2	10	-45.8	-46.9	0.0	-33.3	-21.25	12.03
	HT/VHT20 Beam Forming, M8 to M15	2	7	-42.1	-42.8	0.0	-32.4	-21.25	11.15
	HT/VHT20 STBC, M0 to M7	2	7	-42.1	-42.8	0.0	-32.4	-21.25	11.15
5795	Non HT40, 6 to 54 Mbps	1	7	-42.7		0.0	-35.7	-21.25	14.42
	Non HT40, 6 to 54 Mbps	2	7	-42.7	-44.2	0.0	-33.3	-21.25	12.10
	HT/VHT40, M0 to M7	1	7	-42.1		0.0	-35.1	-21.25	13.81
	HT/VHT40, M0 to M7	2	7	-42.3	-42.9	0.0	-32.5	-21.25	11.29
	HT/VHT40, M8 to M15	2	7	-42.3	-42.9	0.0	-32.5	-21.25	11.29
	HT/VHT40 Beam Forming, M0 to M7	2	10	-46.6	-47.3	0.0	-33.9	-21.25	12.63
	HT/VHT40 Beam Forming, M8 to M15	2	7	-42.3	-42.9	0.0	-32.5	-21.25	11.29
	HT/VHT40 STBC, M0 to M7	2	7	-42.3	-42.9	0.0	-32.5	-21.25	11.29
5825	Non HT20, 6 to 54 Mbps	1	7	-41.9		0.0	-34.9	-21.25	13.63
	Non HT20, 6 to 54 Mbps	2	7	-41.9	-42.5	0.0	-32.2	-21.25	10.90
	Non HT20 Beam Forming, 6 to 54 Mbps	2	10	-45.3	-47.2	0.0	-33.1	-21.25	11.86
	HT/VHT20, M0 to M7	1	7	-42.5		0.0	-35.5	-21.25	14.22
	HT/VHT20, M0 to M7	2	7	-42.3	-42.9	0.0	-32.6	-21.25	11.30
	HT/VHT20, M8 to M15	2	7	-42.3	-42.9	0.0	-32.6	-21.25	11.30
	HT/VHT20 Beam Forming, M0 to M7	2	10	-45.7	-47.4	0.0	-33.4	-21.25	12.18
	HT/VHT20 Beam Forming, M8 to M15	2	7	-42.3	-42.9	0.0	-32.6	-21.25	11.30
	HT/VHT20 STBC, M0 to M7	2	7	-42.3	-42.9	0.0	-32.6	-21.25	11.30



Conducted Spurs Peak, 5775 MHz, VHT80, M0 to M9 1ss

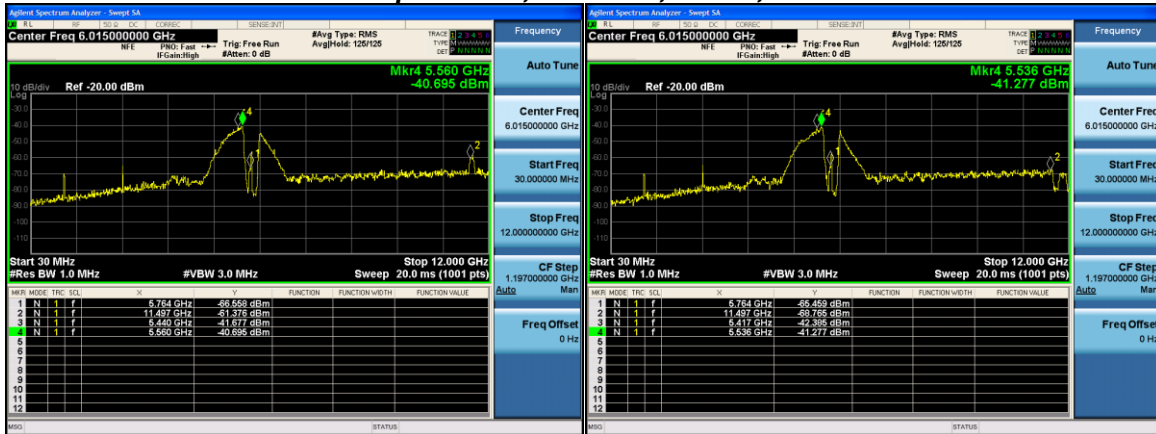

Antenna A

Antenna B



A.7 Conducted Bandedge

15.205 / 15.247 / LP0002 / RSS-247 In any 100 kHz bandwidth outside the frequency band in which the digitally modulated intentional radiator is operating, the radio frequency power that is produced by the intentional radiator shall be at least 30 dB below that in the 100 kHz bandwidth within the band that contains the highest level of the desired power.

Devices certified before March 2, 2018 with antenna gain of 10 dBi or less may demonstrate compliance with the emission limits in §15.247(d), but manufacturing, marketing and importing of devices certified under this alternative must cease before March 2, 2020.

Test Procedure

Ref. KDB 558074 D01 DTS Meas Guidance v03r05
ANSI C63.10: 2013

<p>Conducted Band edge Test Procedure</p> <ol style="list-style-type: none"> 1. Connect the antenna port(s) to the spectrum analyzer input. 2. Place the radio in continuous transmit mode. Use the procedures in KDB 558074 D01 DTS Meas Guidance v03r05 to substitute conducted measurements in place of radiated measurements. 3. Configure Spectrum analyzer as per test parameters below (be sure to enter all losses between the transmitter output and the spectrum analyzer). 4. Place a marker at the end of the restricted band closest to the transmit frequency to show compliance. Also measure any emissions in the restricted bands.. 5. The “measure-and-sum technique” is used for measuring in-band transmit power of a device. In the measure-and-sum approach, the conducted emission level is measured at each antenna port. The measured results at the various antenna ports are then summed mathematically to determine the total emission level from the device. Summing is performed in linear power units. The worst case output is recorded. 6. Place a marker at the end of the restricted band closest to the transmit frequency to show compliance. Also measure any emissions in the restricted bands 7. Capture graphs and record pertinent measurement data.
--

<p>Conducted Bandedge Test parameters non-restricted Band KDB 558074 D01 v03r05 section 11.1b, 11.2-3, also see ANSI C63.10: 2013 section 11.10.3</p>
<p>RBW = 100 kHz VBW ≥ 3 x RBW Sweep = Auto couple Detector = Peak Trace = Max Hold.</p>

System Number	Description	Samples	System under test	Support equipment
1	EUT	S01	<input checked="" type="checkbox"/>	<input type="checkbox"/>
	Support	S02	<input type="checkbox"/>	<input checked="" type="checkbox"/>

<p>Tested By : Julian Land</p>	<p>Date of testing: 04-Oct-19 - 05-Oct-19</p>
<p>Test Result : PASS</p>	

See Appendix B for list of test equipment

Conducted Bandedge Peak (Left Side)

Frequency (MHz)	Mode	Tx Paths	Correlated Antenna Gain (dBi)	Tx 1 Bandedge Level (dBm)	Tx 2 Bandedge Level (dBm)	Total Tx Bandedge Level (dBm)	Limit (dBm)	Margin (dB)
5745	Non HT20, 6 to 54 Mbps	1	7	-46.7		-39.7	-27.00	12.68
	Non HT20, 6 to 54 Mbps	2	7	-46.7	-47.4	-37.0	-27.00	10.00
	Non HT20 Beam Forming, 6 to 54 Mbps	2	10	-50.7	-51.9	-38.2	-27.00	11.22
	HT/VHT20, M0 to M7	1	7	-46.7		-39.7	-27.00	12.67
	HT/VHT20, M0 to M7	2	7	-46.7	-46.9	-36.8	-27.00	9.76
	HT/VHT20, M8 to M15	2	7	-46.7	-46.9	-36.8	-27.00	9.76
	HT/VHT20 Beam Forming, M0 to M7	2	10	-50.6	-51.4	-37.9	-27.00	10.94
	HT/VHT20 Beam Forming, M8 to M15	2	7	-46.7	-46.9	-36.8	-27.00	9.76
	HT/VHT20 STBC, M0 to M7	2	7	-46.7	-46.9	-36.8	-27.00	9.76
5755	Non HT40, 6 to 54 Mbps	1	7	-46.5		-39.5	-27.00	12.47
	Non HT40, 6 to 54 Mbps	2	7	-46.5	-47.6	-37.0	-27.00	9.98
	HT/VHT40, M0 to M7	1	7	-46.6		-39.6	-27.00	12.56
	HT/VHT40, M0 to M7	2	7	-46.6	-46.8	-36.6	-27.00	9.65
	HT/VHT40, M8 to M15	2	7	-46.6	-46.8	-36.6	-27.00	9.65
	HT/VHT40 Beam Forming, M0 to M7	2	10	-50.5	-51.6	-38.0	-27.00	10.96
	HT/VHT40 Beam Forming, M8 to M15	2	7	-46.6	-46.8	-36.6	-27.00	9.65
	HT/VHT40 STBC, M0 to M7	2	7	-46.6	-46.8	-36.6	-27.00	9.65
5775	Non HT80, 6 to 54 Mbps	1	7	-47.9		-40.9	-27.00	13.88
	Non HT80, 6 to 54 Mbps	2	7	-47.9	-48.0	-37.9	-27.00	10.92
	VHT80, M0 to M9 1ss	1	7	-42.0		-34.9	-27.00	7.90
	VHT80, M0 to M9 1ss	2	7	-45.6	-44.7	-35.0	-27.00	8.01
	VHT80, M0 to M9 2ss	2	7	-45.6	-44.7	-35.0	-27.00	8.01
	VHT80 Beam Forming, M0 to M9 1ss	2	10	-49.7	-49.1	-36.3	-27.00	9.28
	VHT80 Beam Forming, M0 to M9 2ss	2	7	-45.6	-44.7	-35.0	-27.00	8.01
	VHT80 STBC, M0 to M9 1ss	2	7	-45.6	-44.7	-35.0	-27.00	8.01





Conducted Bandedge Peak 15407L, 5775 MHz, VHT80, M0 to M9 1ss

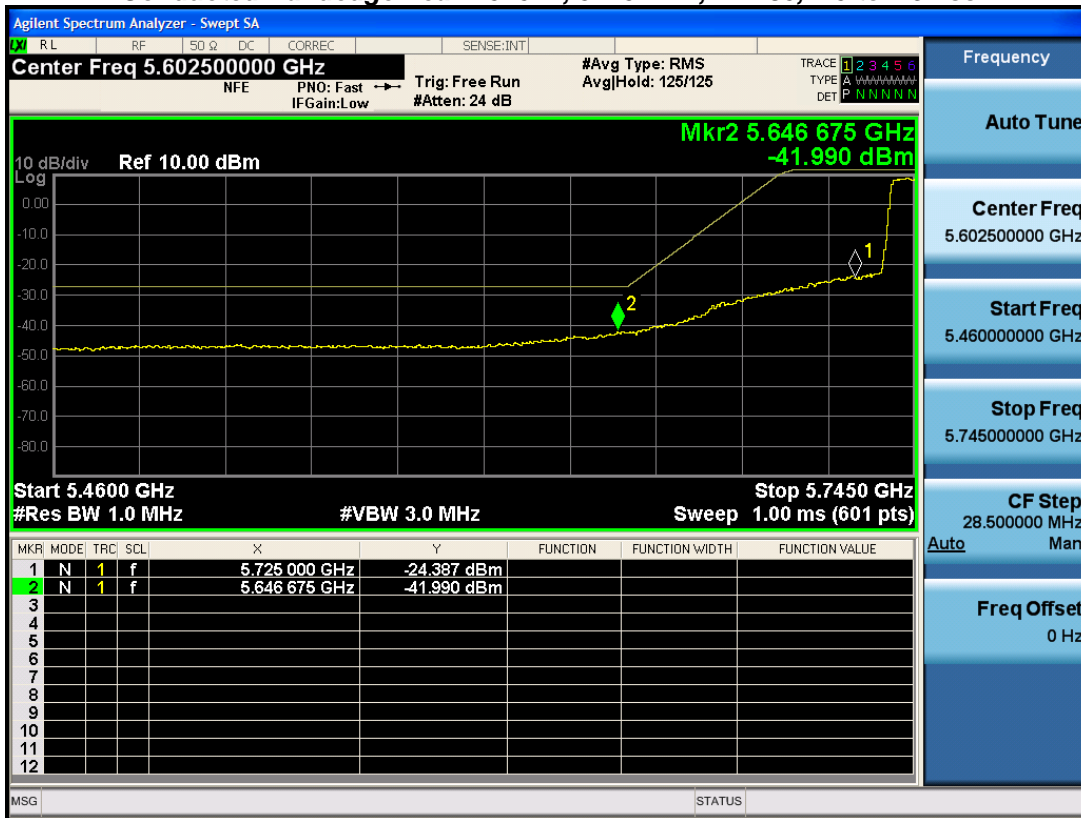

Antenna A

Conducted Bandedge Peak (Right Side)

Frequency (MHz)	Mode	Tx Paths	Correlated Antenna Gain (dBi)	Tx 1 Bandedge Level (dBm)	Tx 2 Bandedge Level (dBm)	Total Tx Bandedge Level (dBm)	Limit (dBm)	Margin (dB)
5775	Non HT80, 6 to 54 Mbps	1	7	-48.2		-41.2	-27.00	14.18
	Non HT80, 6 to 54 Mbps	2	7	-48.2	-47.0	-37.5	-27.00	10.53
	VHT80, M0 to M9 1ss	1	7	-43.8		-36.7	-27.00	9.70
	VHT80, M0 to M9 1ss	2	7	-47.2	-45.1	-35.9	-27.00	8.91
	VHT80, M0 to M9 2ss	2	7	-47.2	-45.1	-35.9	-27.00	8.91
	VHT80 Beam Forming, M0 to M9 1ss	2	10	-50.9	-48.8	-36.6	-27.00	9.61
	VHT80 Beam Forming, M0 to M9 2ss	2	7	-47.2	-45.1	-35.9	-27.00	8.91
	VHT80 STBC, M0 to M9 1ss	2	7	-47.2	-45.1	-35.9	-27.00	8.91
5785	Non HT20, 6 to 54 Mbps	1	7	-47.1		-40.1	-27.00	13.08
	Non HT20, 6 to 54 Mbps	2	7	-47.1	-47.1	-37.1	-27.00	10.06
	Non HT20 Beam Forming, 6 to 54 Mbps	2	10	-50.4	-50.1	-37.2	-27.00	10.21
	HT/VHT20, M0 to M7	1	7	-47.0		-40.0	-27.00	12.97
	HT/VHT20, M0 to M7	2	7	-47.8	-47.2	-37.5	-27.00	10.45
	HT/VHT20, M8 to M15	2	7	-47.8	-47.2	-37.5	-27.00	10.45
	HT/VHT20 Beam Forming, M0 to M7	2	10	-50.2	-50.2	-37.2	-27.00	10.16
	HT/VHT20 Beam Forming, M8 to M15	2	7	-47.8	-47.2	-37.5	-27.00	10.45
	HT/VHT20 STBC, M0 to M7	2	7	-47.8	-47.2	-37.5	-27.00	10.45
5795	Non HT40, 6 to 54 Mbps	1	7	-47.8		-40.8	-27.00	13.77
	Non HT40, 6 to 54 Mbps	2	7	-47.8	-46.7	-37.2	-27.00	10.18
	HT/VHT40, M0 to M7	1	7	-47.5		-40.5	-27.00	13.46
	HT/VHT40, M0 to M7	2	7	-47.5	-47.2	-37.3	-27.00	10.29
	HT/VHT40, M8 to M15	2	7	-47.5	-47.2	-37.3	-27.00	10.29
	HT/VHT40 Beam Forming, M0 to M7	2	10	-51.0	-50.5	-37.7	-27.00	10.69
	HT/VHT40 Beam Forming, M8 to M15	2	7	-47.5	-47.2	-37.3	-27.00	10.29
	HT/VHT40 STBC, M0 to M7	2	7	-47.5	-47.2	-37.3	-27.00	10.29

5825	Non HT20, 6 to 54 Mbps	1	7	-47.7		-40.7	-27.00	13.68
	Non HT20, 6 to 54 Mbps	2	7	-47.7	-47.1	-37.4	-27.00	10.35
	Non HT20 Beam Forming, 6 to 54 Mbps	2	10	-51.1	-50.7	-37.9	-27.00	10.86
	HT/VHT20, M0 to M7	1	7	-47.8		-40.8	-27.00	13.77
	HT/VHT20, M0 to M7	2	7	-47.7	-47.1	-37.4	-27.00	10.35
	HT/VHT20, M8 to M15	2	7	-47.7	-47.1	-37.4	-27.00	10.35
	HT/VHT20 Beam Forming, M0 to M7	2	10	-50.8	-50.5	-37.6	-27.00	10.61
	HT/VHT20 Beam Forming, M8 to M15	2	7	-47.7	-47.1	-37.4	-27.00	10.35
	HT/VHT20 STBC, M0 to M7	2	7	-47.7	-47.1	-37.4	-27.00	10.35

Conducted Bandedge Peak 15407R, 5775 MHz, VHT80, M0 to M9 1ss

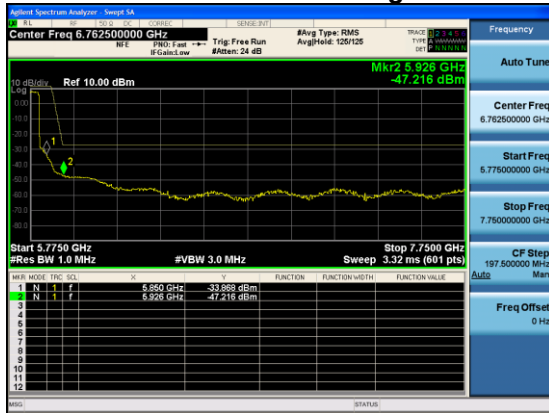

Antenna A

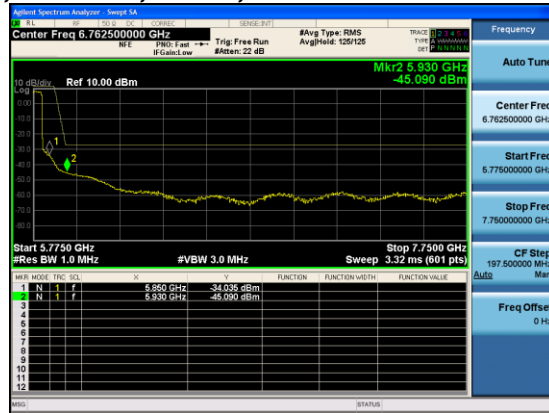

Antenna B



Conducted Bandedge Peak 15407R, 5795 MHz, Non HT40, 6 to 54 Mbps

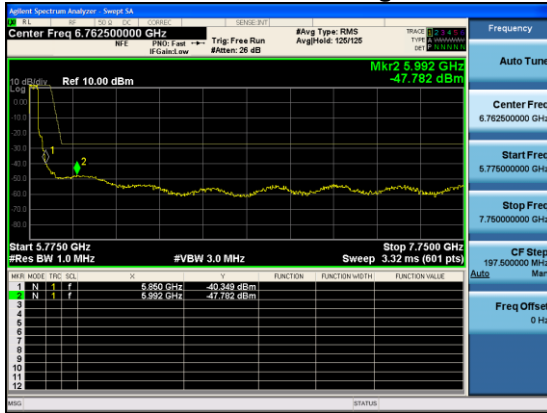

Antenna A

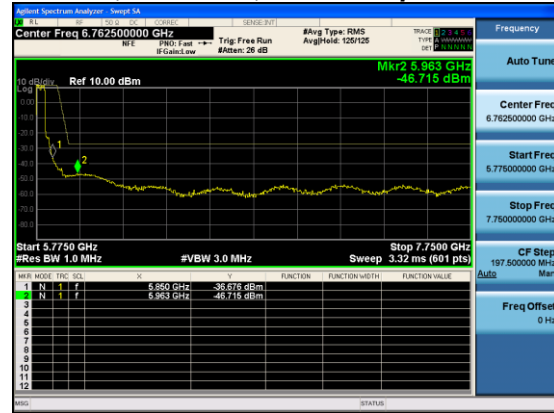

Antenna B

Appendix B: List of Test Equipment Used to perform the test

Equip#	Manufacturer/ Model	Description	Last Cal	Next Due
RF Conducted at output antenna port				
7329	OMEGA/CT485B	Chart Recorder	18 Feb. 2019	18 Feb. 2020
49516	Keysight (Agilent/HP) / N9030A	PXA Signal Analyzer, 3Hz to 50GHz	29 Nov. 2019	29 Nov. 2019
55097	Nattional Instruments / PXI-1042	Chassis PXI	Cal Not Required	Cal Not Required
56089	National Instruments / PXI-2796	40GHz Dual 6x1 Multiplexer (SP6T)	Verify Before Use	Verify Before Use
56328	Pasternack / PE5019-1	Torque Wrench	13 Feb. 2019	13 Feb. 2020
57233	Nattional Instruments / PXI-8115	Embedded Controller	Cal Not Required	Cal Not Required
57253	National Instruments / PXI-2796	40GHz Dual 6x1 Multiplexer (SP6T)	Verify Before Use	Verify Before Use
57254	National Instruments / PXI-2799	Switch 1x1	Verify Before Use	Verify Before Use
57479	CISCO / ATIL	Automation Test Insertion Loss System	Verify Before Use	Verify Before Use

Appendix C: Abbreviation Key and Definitions

The following table defines abbreviations used within this test report.

Abbreviation	Description	Abbreviation	Description
EMC	Electro Magnetic Compatibility	°F	Degrees Fahrenheit
EMI	Electro Magnetic Interference	°C	Degrees Celsius
EUT	Equipment Under Test	Temp	Temperature
ITE	Information Technology Equipment	S/N	Serial Number
TAP	Test Assessment Schedule	Qty	Quantity
ESD	Electro Static Discharge	emf	Electromotive force
EFT	Electric Fast Transient	RMS	Root mean square
EDCS	Engineering Document Control System	Qp	Quasi Peak
Config	Configuration	Av	Average
CIS#	Cisco Number (unique identification number for Cisco test equipment)	Pk	Peak
Cal	Calibration	kHz	Kilohertz (1x10 ³)
EN	European Norm	MHz	MegaHertz (1x10 ⁶)
IEC	International Electro technical Commission	GHz	Gigahertz (1x10 ⁹)
CISPR	International Special Committee on Radio Interference	H	Horizontal
CDN	Coupling/Decoupling Network	V	Vertical
LISN	Line Impedance Stabilization Network	dB	decibel
PE	Protective Earth	V	Volt
GND	Ground	kV	Kilovolt (1x10 ³)
L1	Line 1	μV	Microvolt (1x10 ⁻⁶)
L2	Line2	A	Amp
L3	Line 3	μA	Micro Amp (1x10 ⁻⁶)
DC	Direct Current	mS	Milli Second (1x10 ⁻³)
RAW	Uncorrected measurement value, as indicated by the measuring device	μS	Micro Second (1x10 ⁻⁶)
RF	Radio Frequency	μS	Micro Second (1x10 ⁻⁶)
SLCE	Signal Line Conducted Emissions	m	Meter
Meas dist	Measurement distance	Spec dist	Specification distance
N/A or NA	Not Applicable	SL	Signal Line (or Telecom Line)
P	Power Line	L	Live Line
N	Neutral Line	R	Return
S	Supply	AC	Alternating Current

Appendix D: Photographs of Test Setups

Title: EUT Pictures





Title: Radio Conducted Test Setup

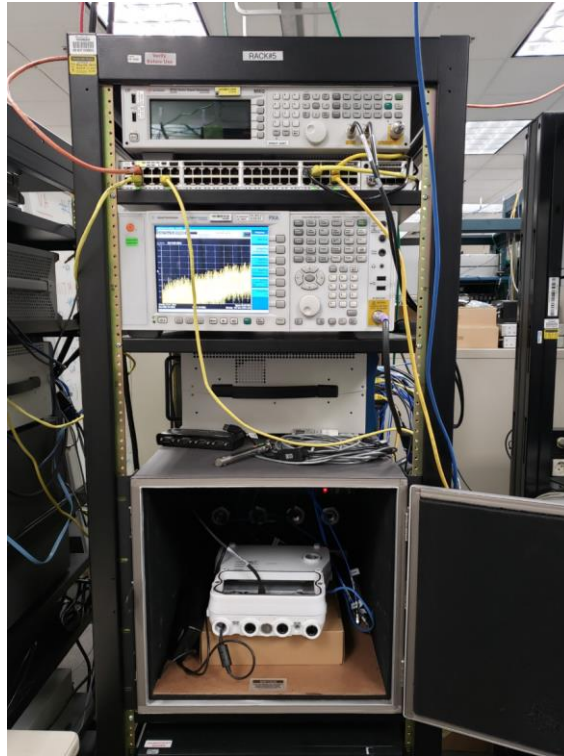

Appendix E: Software Used to Perform Testing

EMlsoft Vasona, version 6.024



Appendix F: Test Procedures

Measurements were made in accordance with

- KDB 789033 - D02 General UNII Test Procedures New Rules v02r01
- KDB 662911 - MIMO
- ANSI C63.4 2014 Unintentional Radiators
- ANSI C63.10 2013 Intentional Radiators

Test procedures are summarized below:

FCC 5GHz Test Procedures	EDCS # 1445048
FCC 5GHz RSE Test Procedures	EDCS # 1511600

Appendix G: Scope of Accreditation (A2LA certificate number 1178-01)

The scope of accreditation of Cisco Systems, Inc. can be found on the A2LA web page at:

<http://www.a2la.org/scopepdf/1178-01.pdf>

End