

FCC Radio Test Report

FCC ID: LDKESPRD2922

Report No. : BTL-FCCP-4-2403T068
Equipment : UC Phone
Model Name : DP-9871
Brand Name :



Applicant : Cisco Systems Inc
Address : 125 West Tasman Drive San Jose, CA 95134-1706 United States

Radio Function : RLAN 5 GHz (U-NII 1, U-NII 2A, U-NII 2C, U-NII 3)

FCC Rule Part(s) : FCC CFR Title 47, Part 15, Subpart E (15.407)
Measurement Procedure(s) : ANSI C63.10-2013

Date of Receipt : 2024/3/12
Date of Test : 2024/3/21 ~ 2024/4/10
Issued Date : 2024/4/25

The above equipment has been tested and found in compliance with the requirement of the above standards by BTL Inc.

Prepared by : 
Eddie Lee, Engineer

Approved by : 
Jerry Chung, Supervisor

**BTL Inc.**

No.18, Ln. 171, Sec. 2, Jiuzong Rd., Neihu Dist., Taipei City 114, Taiwan

Tel: +886-2-2657-3299 Fax: +886-2-2657-3331 Web: www.newbtl.com Service mail: btl_qa@newbtl.com

Declaration

BTL represents to the client that testing is done in accordance with standard procedures as applicable and that test instruments used has been calibrated with standards traceable to international standard(s) and/or national standard(s).

BTL's reports apply only to the specific samples tested under conditions. It is manufacture's responsibility to ensure that additional production units of this model are manufactured with the identical electrical and mechanical components. **BTL** assumes no responsibility for the data provided by the Customer, any statements, inferences or generalizations drawn by the customer or others from the reports issued by **BTL**.

This report is the confidential property of the client. As a mutual protection to the clients, the public and ourselves, the test report shall not be reproduced, except in full, without our written approval.

BTL's laboratory quality assurance procedures are in compliance with the **ISO/IEC 17025** requirements, and accredited by the conformity assessment authorities listed in this test report.

BTL is not responsible for the sampling stage, so the results only apply to the sample as received.

The information, data and test plan are provided by manufacturer which may affect the validity of results, so it is manufacturer's responsibility to ensure that the apparatus meets the essential requirements of applied standards and in all the possible configurations as representative of its intended use.

Limitation

For the use of the authority's logo is limited unless the Test Standard(s)/Scope(s)/Item(s) mentioned in this test report is (are) included in the conformity assessment authorities acceptance respective.

Please note that the measurement uncertainty is provided for informational purpose only and are not use in determining the Pass/Fail results.

CONTENTS

REVISION HISTORY	5
1 SUMMARY OF TEST RESULTS	6
1.1 TEST FACILITY	7
1.2 MEASUREMENT UNCERTAINTY	7
1.3 TEST ENVIRONMENT CONDITIONS	7
1.4 DUTY CYCLE	8
2 GENERAL INFORMATION	9
2.1 DESCRIPTION OF EUT	9
2.2 TEST MODES	12
2.3 BLOCK DIAGRAM SHOWING THE CONFIGURATION OF SYSTEM TESTED	13
2.4 SUPPORT UNITS	14
3 AC POWER LINE CONDUCTED EMISSIONS TEST	15
3.1 LIMIT	15
3.2 TEST PROCEDURE	15
3.3 DEVIATION FROM TEST STANDARD	15
3.4 TEST SETUP	16
3.5 TEST RESULT	16
4 RADIATED EMISSIONS TEST	17
4.1 LIMIT	17
4.2 TEST PROCEDURE	18
4.3 DEVIATION FROM TEST STANDARD	18
4.4 TEST SETUP	19
4.5 EUT OPERATING CONDITIONS	20
4.6 TEST RESULT – BELOW 30 MHZ	20
4.7 TEST RESULT – 30 MHZ TO 1 GHZ	20
4.8 TEST RESULT – ABOVE 1 GHZ	20
5 BANDWIDTH TEST	21
5.1 LIMIT	21
5.2 TEST PROCEDURE	21
5.3 DEVIATION FROM TEST STANDARD	21
5.4 TEST SETUP	21
5.5 EUT OPERATING CONDITIONS	21
5.6 TEST RESULT	21
6 OUTPUT POWER TEST	22
6.1 LIMIT	22
6.2 TEST PROCEDURE	22
6.3 DEVIATION FROM TEST STANDARD	22
6.4 TEST SETUP	22
6.5 EUT OPERATING CONDITIONS	22
6.6 TEST RESULT	22
7 POWER SPECTRAL DENSITY	23
7.1 LIMIT	23
7.2 TEST PROCEDURE	23
7.3 DEVIATION FROM TEST STANDARD	23
7.4 TEST SETUP	23
7.5 EUT OPERATING CONDITIONS	23
7.6 TEST RESULT	23

8	LIST OF MEASURING EQUIPMENTS	24
9	EUT TEST PHOTO	26
10	EUT PHOTOS	26
APPENDIX A	AC POWER LINE CONDUCTED EMISSIONS	27
APPENDIX B	RADIATED EMISSIONS - 9 KHZ TO 30 MHZ	32
APPENDIX C	RADIATED EMISSIONS - 30 MHZ TO 1 GHZ	37
APPENDIX D	RADIATED EMISSIONS - ABOVE 1 GHZ	40
APPENDIX E	BANDWIDTH	148
APPENDIX F	CONDUCTED OUTPUT POWER	173
APPENDIX G	POWER SPECTRAL DENSITY	176

REVISION HISTORY

Report No.	Version	Description	Issued Date	Note
BTL-FCCP-4-2403T068	R00	Original Report.	2024/4/25	Valid

1 SUMMARY OF TEST RESULTS

Test procedures according to the technical standards.

Standard(s) Section	Description	Test Result	Judgement	Remark
15.207	AC Power Line Conducted Emissions	APPENDIX A	Pass	-----
15.205 15.209 15.407(b)	Radiated Emissions	APPENDIX B APPENDIX C APPENDIX D	Pass	-----
15.407(a) 15.407(e)	Bandwidth	APPENDIX E	Pass	-----
15.407(a)	Output Power	APPENDIX F	Pass	-----
15.407(a)	Power Spectral Density	APPENDIX G	Pass	-----
15.203	Antenna Requirement	-----	Pass	-----

NOTE:

- (1) "N/A" denotes test is not applicable in this Test Report.
- (2) The report format version is TP.1.1.1.

1.1 TEST FACILITY

The test locations stated below are under the TAF Accreditation Number 0659.

The test location(s) used to collect the test data in this report are:

No. 68-1, Ln. 169, Sec. 2, Datong Rd., Xizhi Dist., New Taipei City 221, Taiwan
(FCC DN: TW0659)

C05 CB08 CB11 SR10 SR11

No. 72, Ln. 169, Sec. 2, Datong Rd., Xizhi Dist., New Taipei City 221, Taiwan
(FCC DN: TW0659)

C06 CB21 CB22

1.2 MEASUREMENT UNCERTAINTY

The reported uncertainty of measurement $y \pm U$, where expanded uncertainty U is based on a standard uncertainty multiplied by a coverage factor of $k = 2$, providing a level of confidence of approximately **95 %**. The measurement instrumentation uncertainty considerations contained in CISPR 16-4-2. The BTL measurement uncertainty is less than the CISPR 16-4-2 U_{cispr} requirement.

A. AC power line conducted emissions test:

Test Site	Method	Measurement Frequency Range	U (dB)
C05	CISPR	150 kHz ~ 30MHz	3.44

B. Radiated emissions test :

Test Site	Measurement Frequency Range	U,(dB)
CB21	0.03 GHz ~ 0.2 GHz	4.17
	0.2 GHz ~ 1 GHz	4.72
	1 GHz ~ 6 GHz	5.21
	6 GHz ~ 18 GHz	5.51
	18 GHz ~ 26 GHz	3.69
	26 GHz ~ 40 GHz	4.23

C. Conducted test :

Test Item	U,(dB)
Occupied Bandwidth	0.5332
Output power	0.3669
Power Spectral Density	0.6590
Conducted Spurious emissions	0.5416
Conducted Band edges	0.5335
Frequency Stability	0.5333

NOTE:

Unless specifically mentioned, the uncertainty of measurement has not been taken into account to declare the compliance or non-compliance to the specification.

1.3 TEST ENVIRONMENT CONDITIONS

Test Item	Environment Condition	Test Voltage	Tested by
AC Power Line Conducted Emissions	21 °C, 42 %	AC 120V	Ken Lan
Radiated emissions below 1 GHz	Refer to data	AC 120V	Mark Wang Sean Huang
Radiated emissions above 1 GHz	Refer to data	AC 120V	Mark Wang Sean Huang
Bandwidth	24.6 °C, 47 %	AC 120V	Ken Lan
Output Power	25.8 °C, 54 %	AC 120V	Ken Lan
Power Spectral Density	24.6 °C, 47 %	AC 120V	Ken Lan

1.4 DUTY CYCLE

If duty cycle is $\geq 98\%$, duty factor is not required.
 If duty cycle is $< 98\%$, duty factor shall be considered.

Remark	Delta 1			Delta 2	On Time/Period	10 log(1/Duty Cycle)
Mode	ON (ms)	Numbers (ON)	On Time (B) (ms)	Period (ON+OFF) (ms)	Duty Cycle (%)	Duty Factor (dB)
IEEE 802.11a	1.396	1	1.396	1.508	92.57%	0.34
IEEE 802.11n (HT20)	1.304	1	1.304	1.424	91.57%	0.38
IEEE 802.11n (HT40)	0.618	1	0.618	0.758	81.53%	0.89
IEEE 802.11ac (VHT80)	0.292	1	0.292	0.430	67.91%	1.68

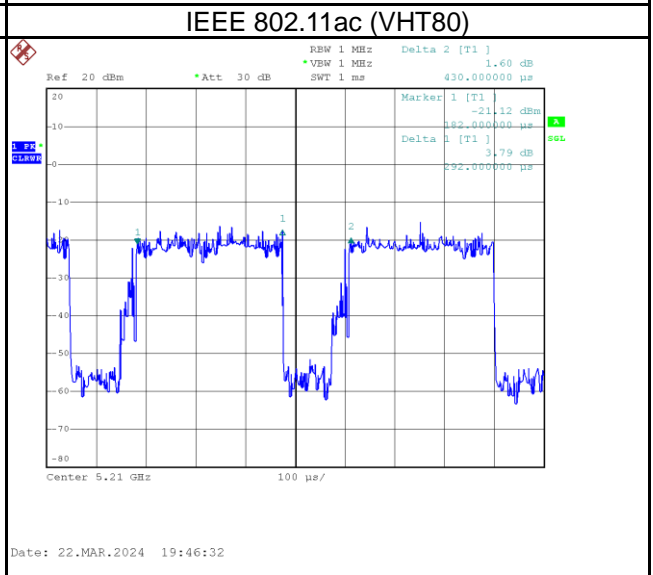
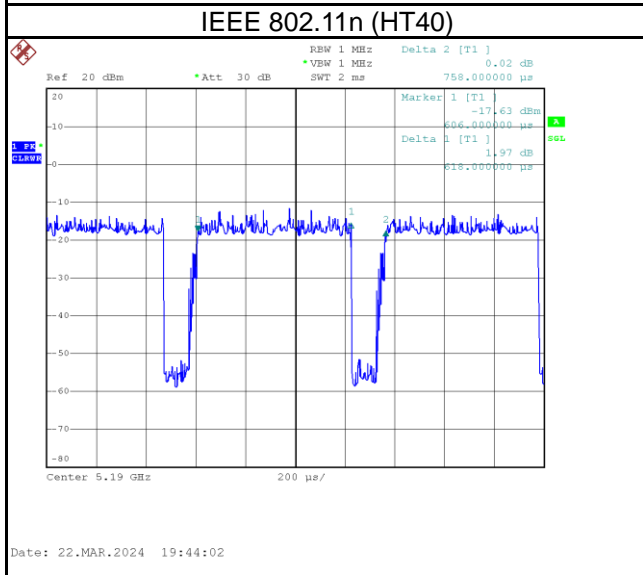
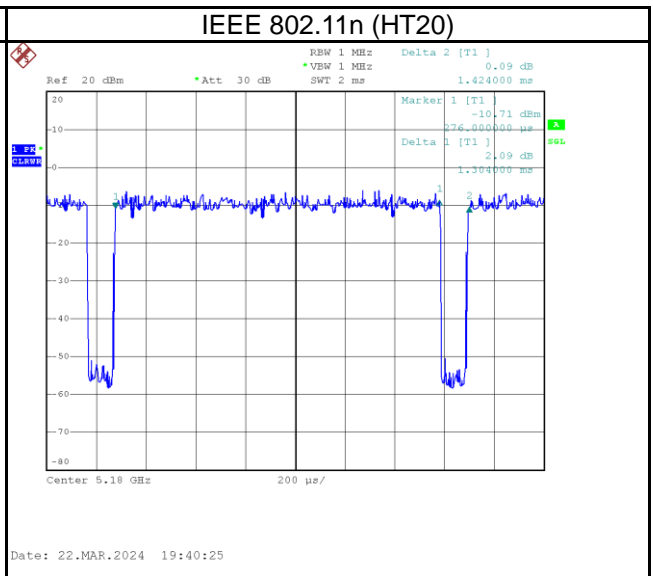
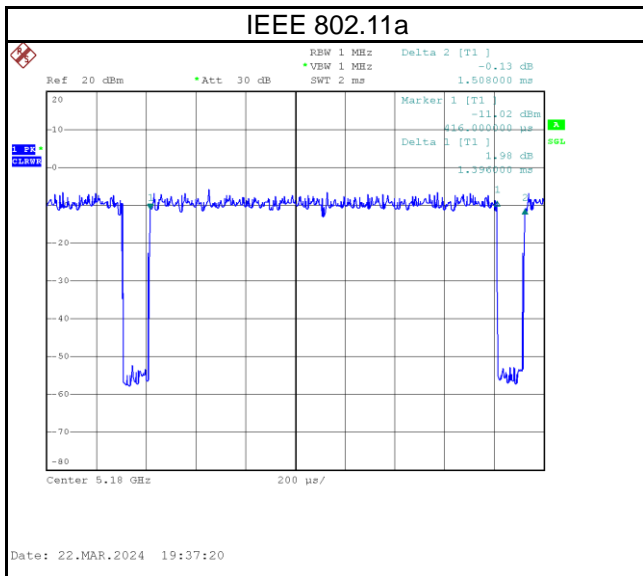

2 GENERAL INFORMATION

2.1 DESCRIPTION OF EUT

Equipment	UC Phone
Model Name	DP-9871
Brand Name	
Model Difference	N/A
Power Source	#1 DC voltage supplied from AC/DC Adapter. # 2 DC Voltage supplied from PoE Adapter.
Power Rating	#1 I/P: 100-240V~0.5A 50-60Hz O/P: 48.0V---0.42A #2 I/P: 48V---0.42A
Products Covered	1 * AC/DC Adapter: PHIHONG / PSAA20R-480L6C 1 * Handset 1 * Wall Mount Kit 1 * LAN Cable
Operation Band	UNII-1: 5150 MHz to 5250 MHz UNII-2A: 5250 MHz to 5350 MHz UNII-2C: 5470 MHz to 5725 MHz UNII-3: 5725 MHz to 5850 MHz
Operation Frequency	UNII-1: 5180 MHz to 5240 MHz UNII-2A: 5260 MHz to 5320 MHz UNII-2C: 5500 MHz to 5700 MHz UNII-3: 5745 MHz to 5825 MHz
Modulation Technology	OFDM
Transfer Rate	802.11a: 54/48/36/24/18/12/9/6 Mbps 802.11n: Up to 150 Mbps 802.11ac: Up to 433.3 Mbps
Output Power Max. for UNII-1	IEEE 802.11a: 12.99 dBm (0.0199 W) IEEE 802.11n (HT20): 12.92 dBm (0.0196 W) IEEE 802.11n (HT40): 11.97 dBm (0.0157 W) IEEE 802.11ac (VHT80): 10.29 dBm (0.0107 W)
Output Power Max. for UNII-2A	IEEE 802.11a: 12.92 dBm (0.0196 W) IEEE 802.11n (HT20): 12.95 dBm (0.0197 W) IEEE 802.11n (HT40): 11.90 dBm (0.0155 W) IEEE 802.11ac (VHT80): 10.32 dBm (0.0108 W)
Output Power Max. for UNII-2C	IEEE 802.11a: 12.95 dBm (0.0197 W) IEEE 802.11n (HT20): 12.98 dBm (0.0199 W) IEEE 802.11n (HT40): 11.98 dBm (0.0158 W) IEEE 802.11ac (VHT80): 10.46 dBm (0.0111 W)
Output Power Max. for UNII-3	IEEE 802.11a: 12.98 dBm (0.0199 W) IEEE 802.11n (HT20): 12.98 dBm (0.0199 W) IEEE 802.11n (HT40): 11.97 dBm (0.0157 W) IEEE 802.11ac (VHT80): 10.05 dBm (0.0101 W)
Test Software Version	Tera Term Version 4.105
Test Model	DP-9871
Sample Status	Engineering Sample
EUT Modification(s)	N/A

NOTE:

- (1) The above EUT information is declared by manufacturer and for more detailed features description, please refers to the manufacturer's specifications or user's manual.

(2) Channel List:

IEEE 802.11a IEEE 802.11n (HT20) IEEE 802.11ac (VHT20)		IEEE 802.11n (HT40) IEEE 802.11ac (VHT40)		IEEE 802.11ac (VHT80)	
UNII-1		UNII-1		UNII-1	
Channel	Frequency (MHz)	Channel	Frequency (MHz)	Channel	Frequency (MHz)
36	5180	38	5190	42	5210
40	5200	46	5230		
44	5220				
48	5240				

IEEE 802.11a IEEE 802.11n (HT20) IEEE 802.11ac (VHT20)		IEEE 802.11n (HT40) IEEE 802.11ac (VHT40)		IEEE 802.11ac (VHT80)	
UNII-2A		UNII-2A		UNII-2A	
Channel	Frequency (MHz)	Channel	Frequency (MHz)	Channel	Frequency (MHz)
52	5260	54	5270	58	5290
56	5280	62	5310		
60	5300				
64	5320				

IEEE 802.11a IEEE 802.11n (HT20) IEEE 802.11ac (VHT20)		IEEE 802.11n (HT40) IEEE 802.11ac (VHT40)		IEEE 802.11ac (VHT80)	
UNII-2C		UNII-2C		UNII-2C	
Channel	Frequency (MHz)	Channel	Frequency (MHz)	Channel	Frequency (MHz)
100	5500	102	5510	106	5530
104	5520	110	5550	122	5610
108	5540	118	5590		
112	5560	126	5630		
116	5580	134	5670		
120	5600				
124	5620				
128	5640				
132	5660				
136	5680				
140	5700				

IEEE 802.11a IEEE 802.11n (HT20) IEEE 802.11ac (VHT20)		IEEE 802.11n (HT40) IEEE 802.11ac (VHT40)		IEEE 802.11ac (VHT80)	
UNII-3		UNII-3		UNII-3	
Channel	Frequency (MHz)	Channel	Frequency (MHz)	Channel	Frequency (MHz)
149	5745	151	5755	155	5775
153	5765	159	5795		
157	5785				
161	5805				
165	5825				

(3) Table for Filed Antenna:

Antenna	Brand	Model Name	Antenna Type	Connector	Frequency (MHz)	Gain (dBi)
1	Foxconn	NFSP-202310 16003	Dipole (On-Board)	N/A	5150 - 5250	3.60
					5250 - 5350	3.62
					5470 - 5725	4.23
					5725 - 5850	4.13

(4) The above Antenna information are derived from the antenna data sheet provided by manufacturer and for more detailed features description, please refer to the manufacturer's specifications, the laboratory shall not be held responsible.

2.2 TEST MODES

Test Items	Test mode	Channel	Note
AC power line conducted emissions	Normal/Idle	-	-
Transmitter Radiated Emissions (below 1GHz)	TX Mode_IEEE 802.11ac (VHT80)	58	-
Transmitter Radiated Emissions (above 1GHz)	TX Mode_IEEE 802.11a	36/48, 52/64	Bandedge
	TX Mode_IEEE 802.11n (HT20)	100/140, 149/165	
	TX Mode_IEEE 802.11n (HT40)	38/46, 54/62 102/134, 151/159	
	TX Mode_IEEE 802.11ac (VHT80)	42, 58 106/122, 155	
	TX Mode_IEEE 802.11a	36/40/48 52/60/64 100/116/140 149/157/165	Harmonic
	TX Mode_IEEE 802.11n (HT20)	36/40/48 52/60/64 100/116/140 149/157/165	
	TX Mode_IEEE 802.11n (HT40)	38/46, 54/62 102/110/134 151/159	
	TX Mode_IEEE 802.11ac (VHT80)	42, 58 106/122, 155	
Transmitter Radiated Emissions (above 18GHz)	TX Mode_IEEE 802.11ac (VHT80)	58	-
Bandwidth	TX Mode_IEEE 802.11a	36/40/48 52/60/64 100/116/140 149/157/165	-
	TX Mode_IEEE 802.11n (HT20)	36/40/48 52/60/64 100/116/140 149/157/165	
	TX Mode_IEEE 802.11n (HT40)	38/46, 54/62 102/110/134 151/159	
	TX Mode_IEEE 802.11ac (VHT80)	42, 58 106/122, 155	
Power Spectral Density & Output Power	TX Mode_IEEE 802.11a	36/40/48 52/60/64 100/116/140 149/157/165	-
	TX Mode_IEEE 802.11n (HT20)	36/40/48 52/60/64 100/116/140 149/157/165	
	TX Mode_IEEE 802.11n (HT40)	38/46, 54/62 102/110/134 151/159	
	TX Mode_IEEE 802.11ac (VHT80)	42, 58 106/122, 155	

NOTE:

- (1) For radiated emission band edge test, both Vertical and Horizontal are evaluated, but only the worst case (Horizontal) is recorded.
- (2) All X, Y and Z axes are evaluated, but only the worst case (X axis) is recorded.

2.3 BLOCK DIAGRAM SHOWING THE CONFIGURATION OF SYSTEM TESTED

Equipment letters and Cable numbers refer to item numbers described in the tables of clause 2.4.

AC power line conducted emissions

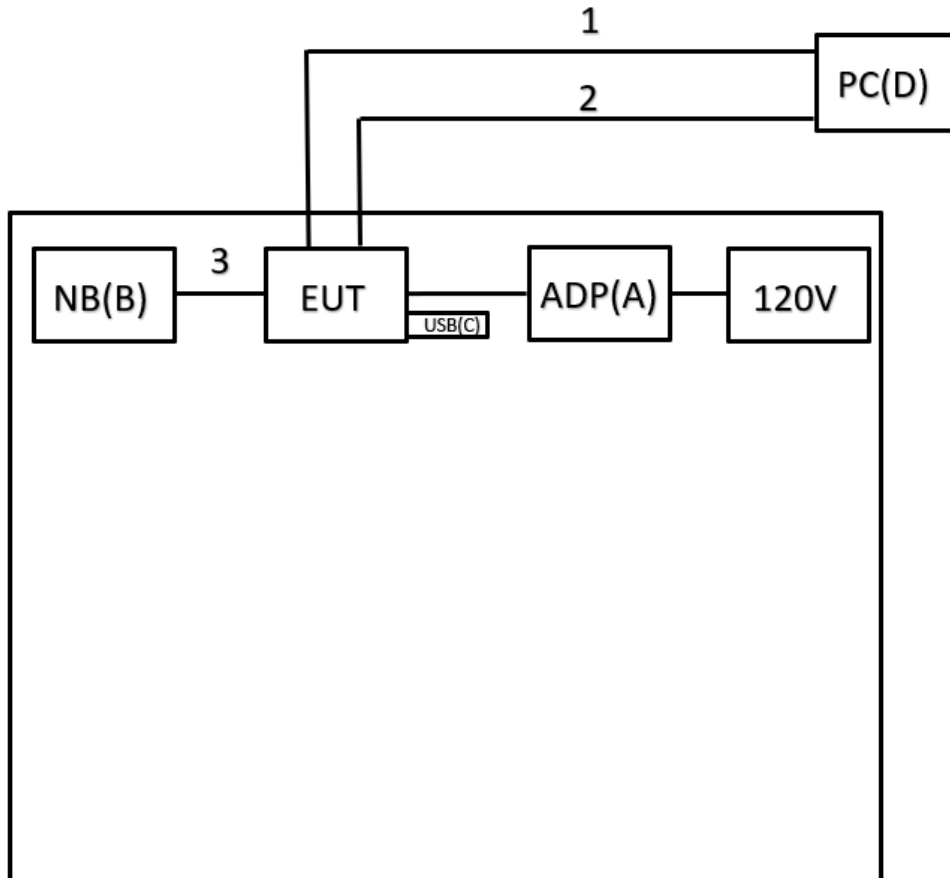

Radiated Emissions

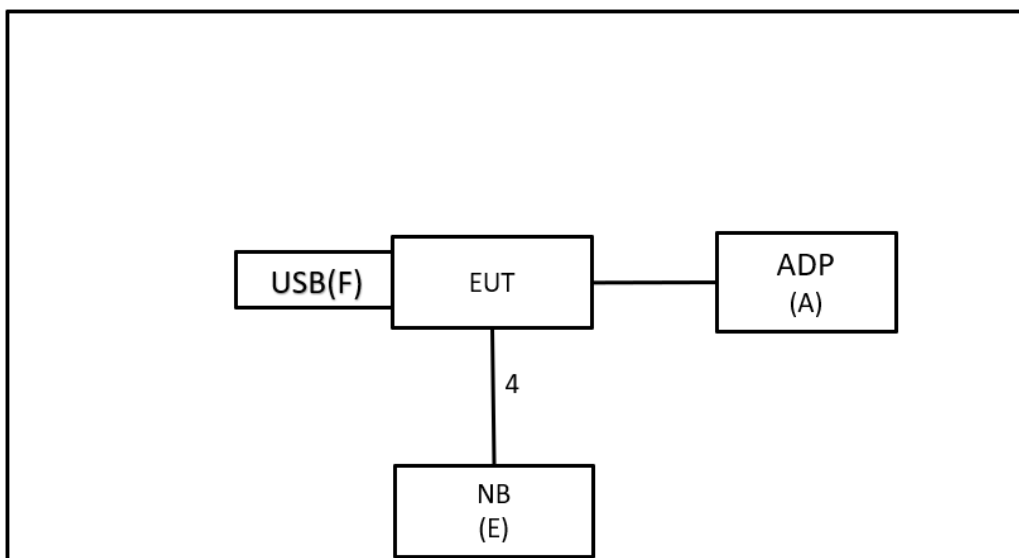

2.4 SUPPORT UNITS

Item	Equipment	Brand	Model No.	Series No.	Remarks
A	SHITCHING POWER SUPPLY	PHIHONG	PSAA20R-480L6C	N/A	Supplied by test requester
B	NB	HP	TPN-125	N/A	Furnished by test lab.
C	USB	Kingston	DT50	N/A	Furnished by test lab.
D	PC	FUJITSU	PRIMERGY TXI 310 MI	N/A	Furnished by test lab.
E	NB	HP	TPN-I119	N/A	Furnished by test lab.
F	USB	ADATA	UV150	N/A	Furnished by test lab.

Item	Shielded	Ferrite Core	Length	Cable Type	Remarks
1	No	No	5m	LAN Cable	Furnished by test lab.
2	No	No	5m	LAN Cable	Furnished by test lab.
3	No	No	0.6m	Cable	Furnished by test lab.
4	No	No	1.8m	LAN Cable	Supplied by test requester

3 AC POWER LINE CONDUCTED EMISSIONS TEST

3.1 LIMIT

Frequency (MHz)	Limit (dB μ V)	
	Quasi-peak	Average
0.15 - 0.5	66 - 56 *	56 - 46 *
0.50 - 5.0	56	46
5.0 - 30.0	60	50

NOTE:

- (1) The tighter limit applies at the band edges.
- (2) The limit of " * " marked band means the limitation decreases linearly with the logarithm of the frequency in the range.
- (3) The test result calculated as following:
 Measurement Value = Reading Level + Correct Factor
 Correct Factor = Insertion Loss + Cable Loss + Attenuator Factor (if use)
 Margin Level = Measurement Value – Limit Value
 Calculation example:

Reading Level (dB μ V)		Correct Factor (dB)		Measurement Value (dB μ V)
38.22	+	3.45	=	41.67

Measurement Value (dB μ V)		Limit Value (dB μ V)		Margin Level (dB)
41.67	-	60	=	-18.33

The following table is the setting of the receiver.

Receiver Parameter	Setting
Attenuation	10 dB
Start Frequency	0.15 MHz
Stop Frequency	30 MHz
IF Bandwidth	9 KHz

3.2 TEST PROCEDURE

- a. The EUT was placed 0.8 m above the horizontal ground plane with the EUT being connected to the power mains through a line impedance stabilization network (LISN).
 All other support equipment were powered from an additional LISN(s).
 The LISN provides 50 Ohm/50uH of impedance for the measuring instrument.
- b. Interconnecting cables that hang closer than 40 cm to the ground plane shall be folded back and forth in the center forming a bundle to keep the cable above 40 cm.
- c. Excess I/O cables that are not connected to a peripheral shall be bundled in the center.
 The end of the cable will be terminated, using the correct terminating impedance.
 The overall length shall not exceed 1 m.
- d. The LISN is spaced at least 80 cm from the nearest part of the EUT chassis.
- e. For the actual test configuration, please refer to the related Item – EUT TEST PHOTO.

NOTE:

- (1) In the results, each reading is marked as Peak, QP or AVG per the detector used.
 BW=9 kHz (6 dB Bandwidth)
- (2) All readings are Peak unless otherwise stated QP or AVG in column of Note. Both the QP and the AVG readings must be less than the limit for compliance.

3.3 DEVIATION FROM TEST STANDARD

No deviation.

3.4 TEST SETUP

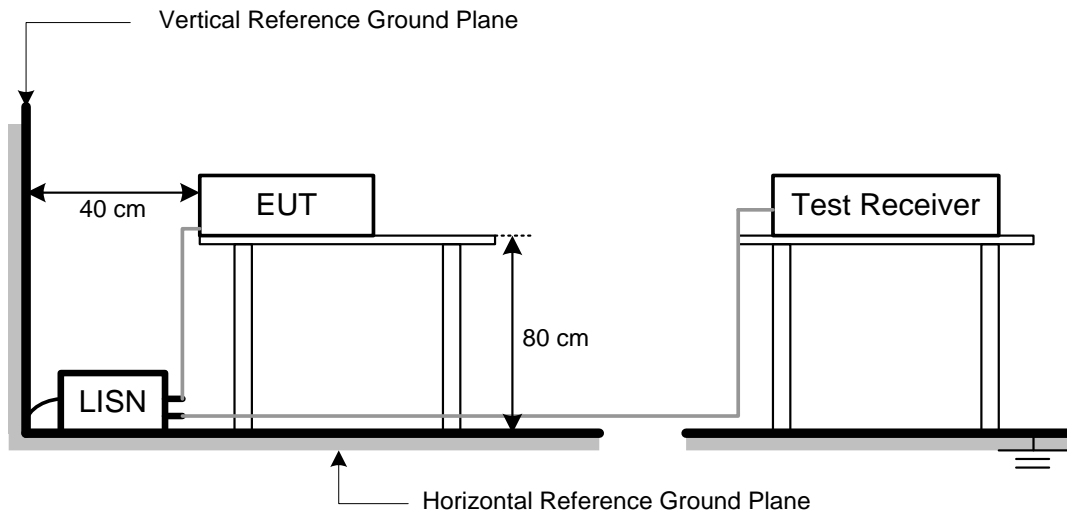

3.5 TEST RESULT

Please refer to the APPENDIX A.

4 RADIATED EMISSIONS TEST

4.1 LIMIT

In case the emission fall within the restricted band specified on 15.205, then the 15.209 limit in the table below has to be followed.

LIMITS OF RADIATED EMISSIONS MEASUREMENT (9 kHz to 1000 MHz)

Frequency (MHz)	Field Strength (microvolts/meter)	Measurement Distance (meters)
0.009~0.490	2400/F(KHz)	300
0.490~1.705	24000/F(KHz)	30
1.705~30.0	30	30
30~88	100	3
88~216	150	3
216~960	200	3
960~1000	500	3

LIMITS OF UNWANTED EMISSION OUT OF THE RESTRICTED BANDS

Frequency (MHz)	EIRP Limit (dBm)	Equivalent Field Strength at 3m (dB μ V/m)
5150-5250	-27	68.3
5250-5350	-27	68.3
5470-5725	-27	68.3
5725-5850	-27 (NOTE 2)	68.3
	10 (NOTE 2)	105.3
	15.6 (NOTE 2)	110.9
	27 (NOTE 2)	122.3

NOTE:

(1) The following formula is used to convert the equipment isotropic radiated power (eirp) to field strength:

$$E = \frac{1000000\sqrt{30P}}{3} \mu\text{V/m, where P is the eirp (Watts)}$$

(2) According to FCC 16-24, All emissions shall be limited to a level of -27 dBm/MHz at 75 MHz or more above or below the band edge increasing linearly to 10 dBm/MHz at 25 MHz above or below the band edge, and from 25 MHz above or below the band edge increasing linearly to a level of 15.6 dBm/MHz at 5 MHz above or below the band edge, and from 5 MHz above or below the band edge increasing linearly to a level of 27 dBm/MHz at the band edge.

(3) The test result calculated as following:

Measurement Value = Reading Level + Correct Factor

Correct Factor = Antenna Factor + Cable Loss - Amplifier Gain(if use)

Margin Level = Measurement Value - Limit Value

Calculation example:

Reading Level (dBuV)		Correct Factor (dB)		Measurement Value (dBuV/m)
36.23	+	-11.97	=	24.26

Measurement Value (dBuV/m)		Limit Value (dBuV/m)		Margin Level (dB)
24.26	-	40	=	-15.74

Spectrum Parameter	Setting
Attenuation	Auto
Start Frequency	1000 MHz
Stop Frequency	10th carrier harmonic
RBW / VBW (Emission in restricted band)	1MHz / 3MHz for Peak, 1MHz / 1/T for Average

Spectrum Parameter	Setting
Attenuation	Auto
Start ~ Stop Frequency	9KHz~90KHz for PK/AVG detector
Start ~ Stop Frequency	90KHz~110KHz for QP detector
Start ~ Stop Frequency	110KHz~490KHz for PK/AVG detector
Start ~ Stop Frequency	490KHz~30MHz for QP detector
Start ~ Stop Frequency	30MHz~1000MHz for QP detector

4.2 TEST PROCEDURE

- a. The measuring distance of 3 m shall be used for measurements. The EUT was placed on the top of a rotating table 0.8 meter above the ground at a 3 meter semi-anechoic chamber. The table was rotated 360 degrees to determine the position of the highest radiation.(below 1GHz)
- b. The measuring distance of 3 m shall be used for measurements. The EUT was placed on the top of a rotating table 1.5 meter above the ground at a 3 meter semi-anechoic chamber. The table was rotated 360 degrees to determine the position of the highest radiation.(above 1GHz)
- c. The height of the equipment or of the substitution antenna shall be 0.8 m or 1.5 m, the height of the test antenna shall vary between 1 m to 4 m. Both horizontal and vertical polarizations of the antenna are set to make the measurement.
- d. For each suspected emission, the EUT was arranged to its worst case and then the antenna was tuned to heights find the maximum reading (used Bore sight function).
- e. The receiver system was set to peak and average detect function and specified bandwidth with maximum hold mode when the test frequency is above 1GHz.
- f. The initial step in collecting radiated emission data is a receiver peak detector mode pre-scanning the measurement frequency range. Significant peaks are then marked and then Quasi Peak detector mode re-measured.
- g. All readings are Peak unless otherwise stated QP in column of Note. Peak denotes that the Peak reading compliance with the QP Limits and then QP Mode measurement didn't perform. (below 1GHz)
- h. All readings are Peak Mode value unless otherwise stated AVG in column of Note. If the Peak Mode Measured value compliance with the Peak Limits and lower than AVG Limits, the EUT shall be deemed to meet both Peak & AVG Limits and then only Peak Mode was measured, but AVG Mode didn't perform. (above 1GHz)
- i. For the actual test configuration, please refer to the related Item – EUT TEST PHOTO.

4.3 DEVIATION FROM TEST STANDARD

No deviation.

4.4 TEST SETUP

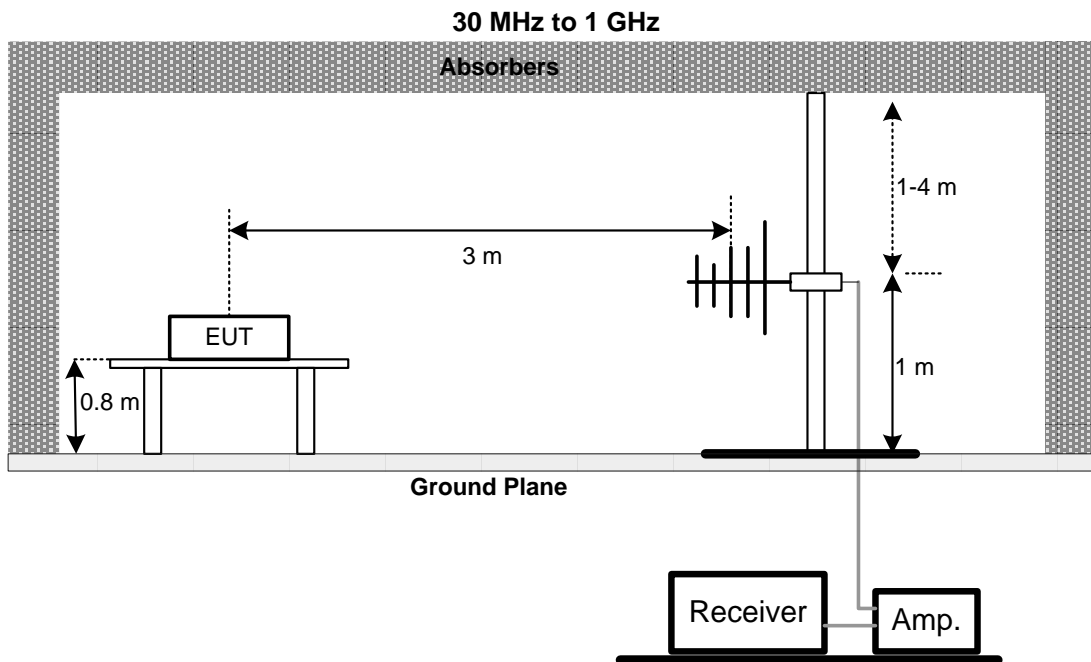
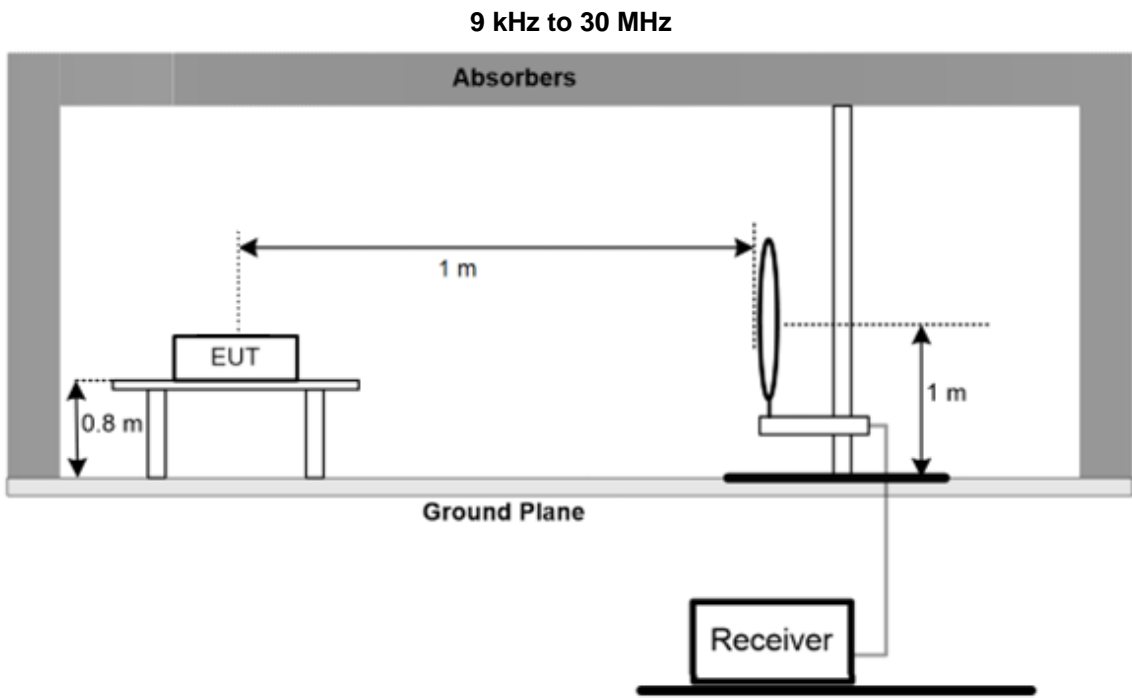

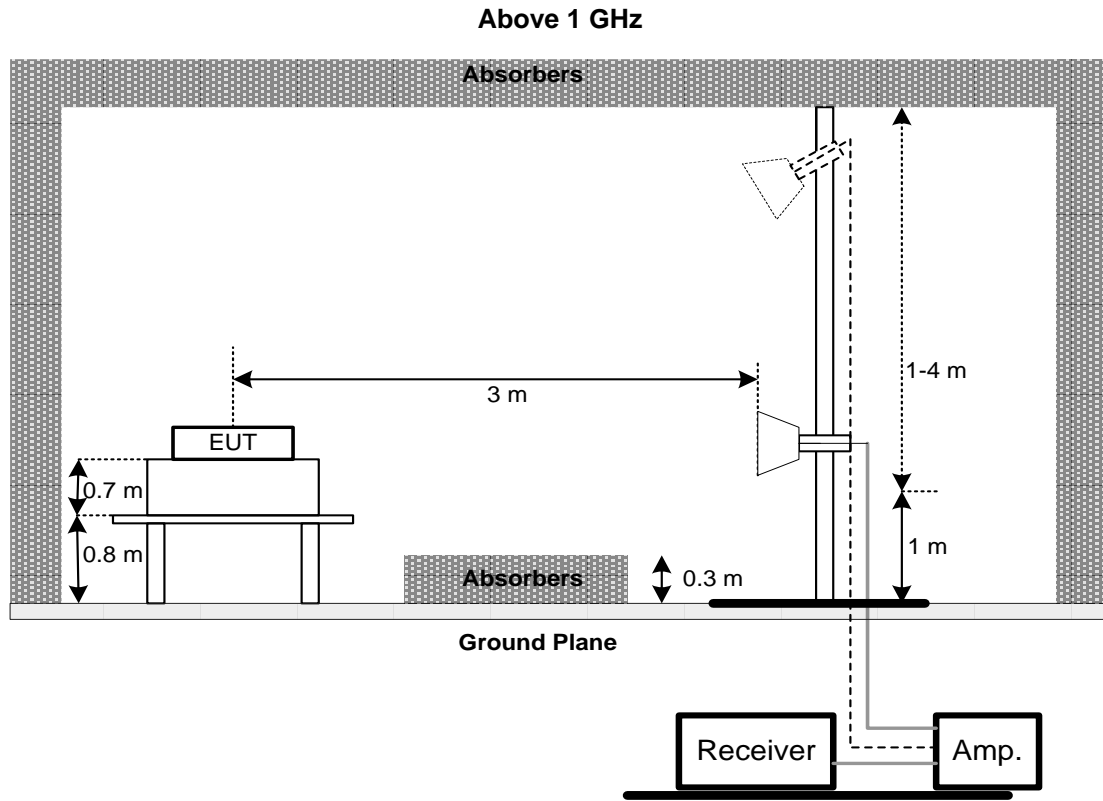

4.5 EUT OPERATING CONDITIONS

The EUT was programmed to be in continuously transmitting mode.

4.6 TEST RESULT – BELOW 30 MHZ

Please refer to the APPENDIX B.

4.7 TEST RESULT – 30 MHZ TO 1 GHZ

Please refer to the APPENDIX C.

4.8 TEST RESULT – ABOVE 1 GHZ

Please refer to the APPENDIX D.

NOTE:

- (1) No limit: This is fundamental signal, the judgment is not applicable. For fundamental signal judgment was referred to Peak output test.

5 BANDWIDTH TEST

5.1 LIMIT

Section	Test Item	Frequency Range (MHz)
15.407(a)	26 dB Bandwidth	5150-5250
		5250-5350
		5470-5725
	Minimum 500 kHz 6 dB Bandwidth	5725-5850

5.2 TEST PROCEDURE

- a. The EUT was directly connected to the spectrum analyzer and antenna output port as show in the block diagram below.
- b. Spectrum Setting:

Spectrum Parameter	Setting
Attenuation	Auto
Span Frequency	> 26 dB Bandwidth
RBW	300 kHz(Bandwidth 20 MHz) 1 MHz(Bandwidth 40 MHz and 80 MHz)
VBW	1 MHz(Bandwidth 20 MHz) 3 MHz(Bandwidth 40 MHz and 80 MHz)
Detector	Peak
Trace	Max Hold
Sweep Time	Auto

5.3 DEVIATION FROM TEST STANDARD

No deviation.

5.4 TEST SETUP



5.5 EUT OPERATING CONDITIONS

The EUT was programmed to be in continuously transmitting mode.

5.6 TEST RESULT

Please refer to the APPENDIX E.

6 OUTPUT POWER TEST

6.1 LIMIT

Section	Test Item	Limit	Frequency Range (MHz)
15.407(a)	Maximum Output Power	Fixed: 1 Watt (30 dBm) Mobile and portable: 250 mW (24 dBm)	5150-5250
		250 mW (24 dBm)	5250-5350
		1 Watt (30dBm)	5470-5725 5725-5850

Note: The maximum e.i.r.p at any elevation angle above 30 degrees as measured from the horizon must not exceed 125 mW(21 dBm).

6.2 TEST PROCEDURE

- a. The EUT was directly connected to the peak power analyzer and antenna output port as show in the block diagram below.
- b. The maximum peak conducted output power was performed in accordance with method of clause E. 3. a) FCC KDB 789033 D02 General UNII Test Procedures New Rules v02r01.
 - a) Method PM (Measurement using an RF average power meter):
 - (i) Measurements may be performed using a wideband RF power meter with a thermocouple detector or equivalent if all of the following conditions are satisfied
The EUT is configured to transmit continuously or to transmit with a constant duty cycle.
At all times when the EUT is transmitting, it must be transmitting at its maximum power control level.
The integration period of the power meter exceeds the repetition period of the transmitted signal by at least a factor of five.
 - (ii) If the transmitter does not transmit continuously, measure the duty cycle, x, of the transmitter output signal as described in II.B.
 - (iii) Measure the average power of the transmitter. This measurement is an average over both the on and off periods of the transmitter.
 - (iv) Adjust the measurement in dBm by adding 10 log (1/x) where x is the duty cycle (e.g., 10 log (1/0.25) if the duty cycle is 25%).

6.3 DEVIATION FROM TEST STANDARD

No deviation.

6.4 TEST SETUP

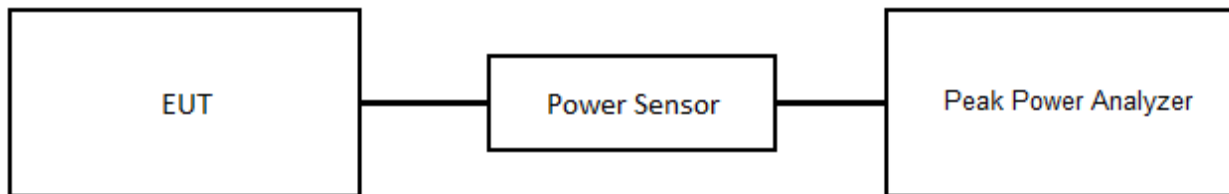

6.5 EUT OPERATING CONDITIONS

The EUT was programmed to be in continuously transmitting mode.

6.6 TEST RESULT

Please refer to the APPENDIX F.

7 POWER SPECTRAL DENSITY

7.1 LIMIT

Section	Test Item	Limit	Frequency Range (MHz)
15.407(a)	Power Spectral Density	Other than Mobile and portable: 17 dBm/MHz	5150-5250
		Mobile and portable: 11 dBm/MHz	
		11 dBm/MHz	5250-5350
		30 dBm/500 kHz	5470-5725
			5725-5850

7.2 TEST PROCEDURE

- a. The EUT was directly connected to the spectrum analyzer and antenna output port as show in the block diagram below.
- b. Spectrum Setting:

Spectrum Parameter	Setting
Attenuation	Auto
Span Frequency	Encompass the entire emissions bandwidth (EBW) of the signal
RBW	= 1 MHz
VBW	≥ 3 MHz
Detector	RMS
Trace	Max Hold
Sweep Time	Auto

7.3 DEVIATION FROM TEST STANDARD

No deviation.

7.4 TEST SETUP

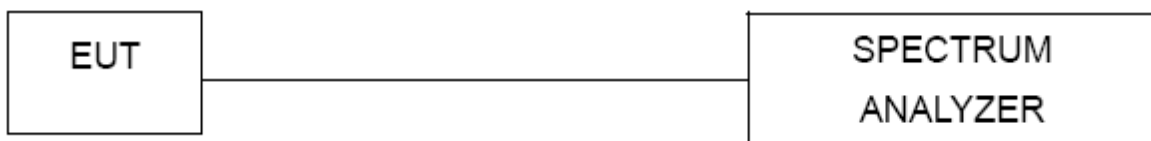

7.5 EUT OPERATING CONDITIONS

The EUT was programmed to be in continuously transmitting mode.

7.6 TEST RESULT

Please refer to the APPENDIX G.

8 LIST OF MEASURING EQUIPMENTS

AC Power Line Conducted Emissions						
Item	Kind of Equipment	Manufacturer	Type No.	Serial No.	Calibrated Date	Calibrated Until
1	TWO-LINE V-NETWORK	R&S	ENV216	101521	2023/9/13	2024/9/12
2	Test Cable	EMCI	EMCCFD300-BM-BMR-5000	220331	2023/3/30	2024/3/29
3	EMI Test Receiver	R&S	ESR 7	101433	2023/11/10	2024/11/9
4	Measurement Software	EZ	EZ EMC (Version NB-03A1-01)	N/A	N/A	N/A

Radiated Emissions						
Item	Kind of Equipment	Manufacturer	Type No.	Serial No.	Calibrated Date	Calibrated Until
1	Preamplifier	EMCI	EMC330N	980850	2023/9/6	2024/9/5
2	Preamplifier	EMCI	EMC118A45SE	980819	2024/3/6	2025/3/5
3	Pre-Amplifier	EMCI	EMC184045SE	980907	2023/9/21	2024/9/20
4	Preamplifier	EMCI	EMC001340	980579	2023/9/6	2024/9/5
5	Test Cable	EMCI	EMC104-SM-1000	180809	2024/3/8	2025/3/7
6	Test Cable	EMCI	EMC104-SM-SM-3000	220322	2024/3/8	2025/3/7
7	Test Cable	EMCI	EMC104-SM-SM-7000	220324	2024/3/8	2025/3/7
8	EXA Signal Analyzer	keysight	N9020B	MY57120120	2024/2/23	2025/2/22
9	Loop Ant	Electro-Metrics	EMCI-LPA600	291	2023/9/12	2024/9/11
10	Horn Antenna	RFSPIN	DRH18-E	211202A18EN	2023/5/12	2024/5/11
11	Horn Ant	Schwarzbeck	BBHA 9170D	1136	2023/5/12	2024/5/11
12	Log-bicon Antenna	Schwarzbeck	VULB9168	1369	2023/5/9	2024/5/8
13	6dB Attenuator	EMCI	EMCI-N-6-06	AT-06001	2023/5/9	2024/5/8
14	Test Cable	EMCI	EMC101G-KM-KM-3000	220329	2024/3/13	2025/3/12
15	Test Cable	EMCI	EMC102-KM-KM-1000	220327	2024/3/13	2025/3/12
16	Measurement Software	EZ	EZ EMC (Version NB-03A1-01)	N/A	N/A	N/A

Bandwidth						
Item	Kind of Equipment	Manufacturer	Type No.	Serial No.	Calibrated Date	Calibrated Until
1	Spectrum Analyzer	R&S	FSP 40	101139	2024/3/8	2025/3/7

Output Power						
Item	Kind of Equipment	Manufacturer	Type No.	Serial No.	Calibrated Date	Calibrated Until
1	Peak Power Analyzer	Keysight	8990B	MY51000517	2024/3/12	2025/3/11
2	Power Sensor	Keysight	N1923A	MY58310005	2024/3/12	2025/3/11

Power Spectral Density						
Item	Kind of Equipment	Manufacturer	Type No.	Serial No.	Calibrated Date	Calibrated Until
1	Spectrum Analyzer	R&S	FSP 40	101139	2024/3/8	2025/3/7

Remark: "N/A" denotes no model name, no serial no. or no calibration specified.
All calibration period of equipment list is one year.

9 EUT TEST PHOTO

Please refer to document Appendix No.: TP-2403T068-FCCP-1 (APPENDIX-TEST PHOTOS).

10 EUT PHOTOS

Please refer to document Appendix No.: EP-2403T068-1 (APPENDIX-EUT PHOTOS).

APPENDIX A AC POWER LINE CONDUCTED EMISSIONS

Test Mode	Normal	Tested Date	2024/3/21
Test Frequency	-	Phase	Line

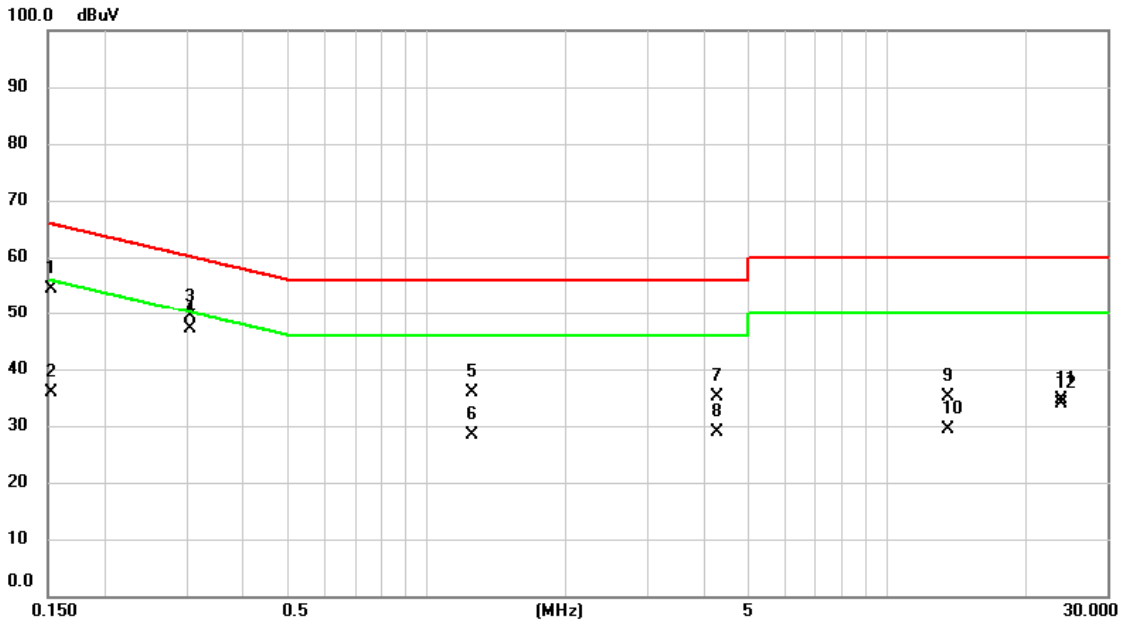

No.	Mk.	Freq. MHz	Reading Level dBuV	Correct Factor dB	Measure- ment dBuV	Limit dBuV	Margin dB	Detector	Comment
1		0.1522	44.68	9.59	54.27	65.88	-11.61	QP	
2		0.1522	26.33	9.59	35.92	55.88	-19.96	AVG	
3		0.3052	39.80	9.57	49.37	60.10	-10.73	QP	
4	*	0.3052	37.62	9.57	47.19	50.10	-2.91	AVG	
5		1.2548	26.40	9.59	35.99	56.00	-20.01	QP	
6		1.2548	18.72	9.59	28.31	46.00	-17.69	AVG	
7		4.2404	25.60	9.63	35.23	56.00	-20.77	QP	
8		4.2404	19.25	9.63	28.88	46.00	-17.12	AVG	
9		13.5600	25.43	9.77	35.20	60.00	-24.80	QP	
10		13.5600	19.65	9.77	29.42	50.00	-20.58	AVG	
11		23.7728	24.79	9.85	34.64	60.00	-25.36	QP	
12		23.7728	23.99	9.85	33.84	50.00	-16.16	AVG	

REMARKS:

- (1) Measurement Value = Reading Level + Correct Factor.
- (2) Margin Level = Measurement Value - Limit Value.

Test Mode	Normal	Tested Date	2024/3/21
Test Frequency	-	Phase	Neutral

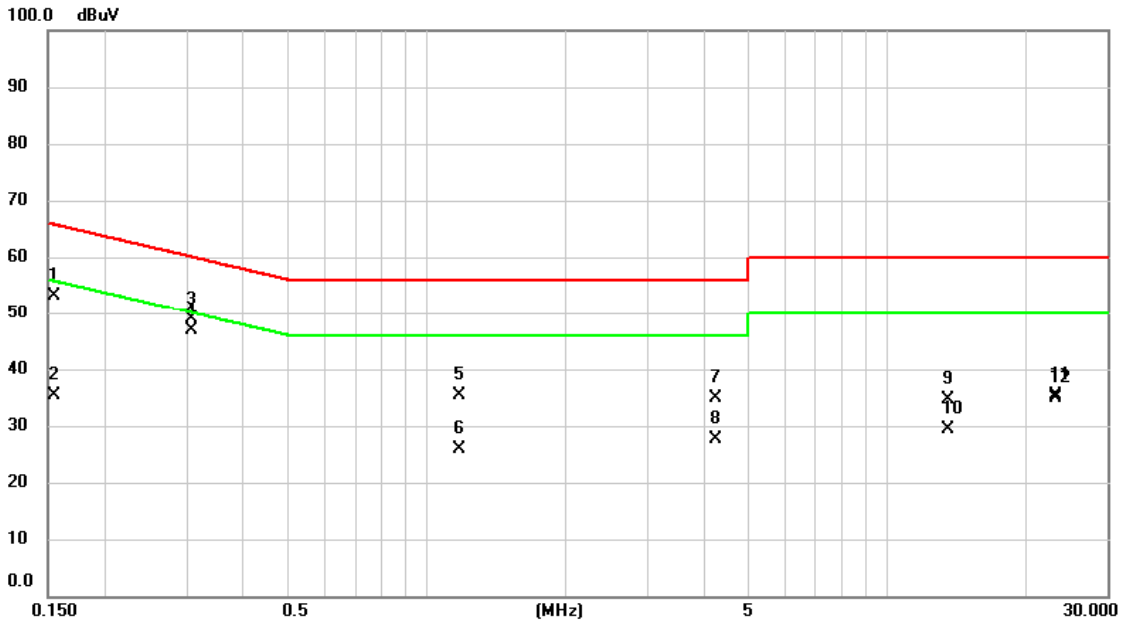

No.	Mk.	Freq. MHz	Reading Level dBuV	Correct Factor dB	Measure- ment dBuV	Limit dBuV	Margin dB	Detector	Comment
1		0.1545	43.58	9.59	53.17	65.75	-12.58	QP	
2		0.1545	25.85	9.59	35.44	55.75	-20.31	AVG	
3		0.3075	39.35	9.57	48.92	60.04	-11.12	QP	
4	*	0.3075	37.34	9.57	46.91	50.04	-3.13	AVG	
5		1.1782	25.83	9.58	35.41	56.00	-20.59	QP	
6		1.1782	16.36	9.58	25.94	46.00	-20.06	AVG	
7		4.2360	25.19	9.63	34.82	56.00	-21.18	QP	
8		4.2360	18.11	9.63	27.74	46.00	-18.26	AVG	
9		13.5600	24.95	9.77	34.72	60.00	-25.28	QP	
10		13.5600	19.49	9.77	29.26	50.00	-20.74	AVG	
11		23.2598	25.58	9.85	35.43	60.00	-24.57	QP	
12		23.2598	25.00	9.85	34.85	50.00	-15.15	AVG	

REMARKS:

(1) Measurement Value = Reading Level + Correct Factor.

(2) Margin Level = Measurement Value - Limit Value.

Test Mode	Idle	Tested Date	2024/3/21
Test Frequency	-	Phase	Line

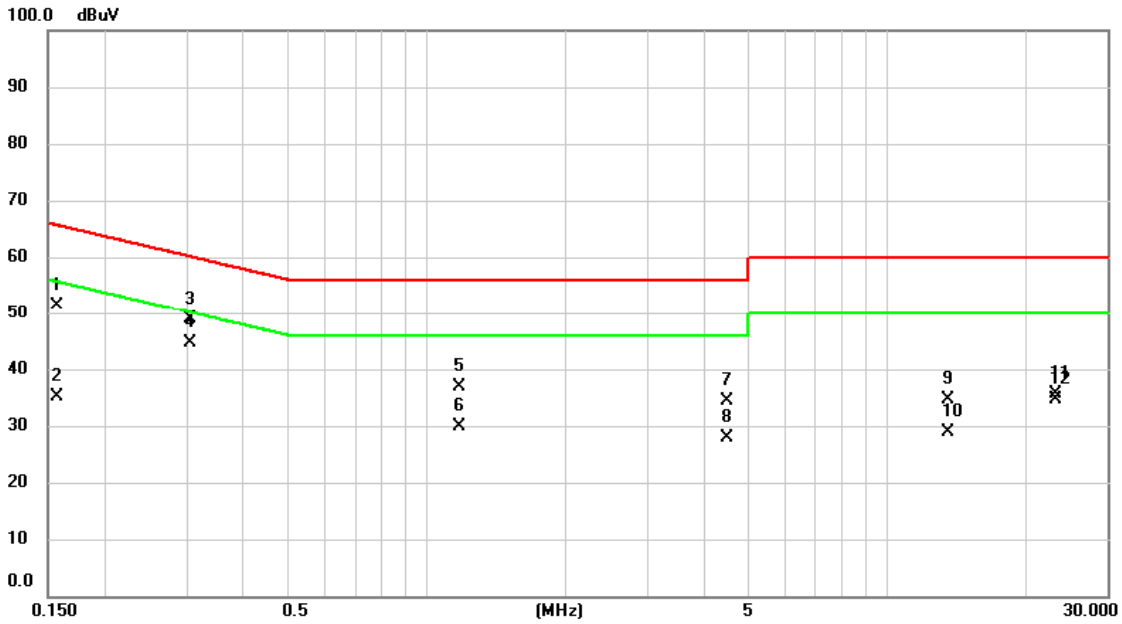

No.	Mk.	Freq. MHz	Reading Level dBuV	Correct Factor dB	Measure- ment dBuV	Limit dBuV	Margin dB	Detector	Comment
1		0.1568	41.81	9.60	51.41	65.63	-14.22	QP	
2		0.1568	25.61	9.60	35.21	55.63	-20.42	AVG	
3		0.3052	39.32	9.58	48.90	60.10	-11.20	QP	
4	*	0.3052	34.95	9.58	44.53	50.10	-5.57	AVG	
5		1.1737	27.25	9.59	36.84	56.00	-19.16	QP	
6		1.1737	20.29	9.59	29.88	46.00	-16.12	AVG	
7		4.4565	24.72	9.64	34.36	56.00	-21.64	QP	
8		4.4565	18.35	9.64	27.99	46.00	-18.01	AVG	
9		13.5600	24.89	9.72	34.61	60.00	-25.39	QP	
10		13.5600	19.27	9.72	28.99	50.00	-21.01	AVG	
11		23.2575	25.82	9.70	35.52	60.00	-24.48	QP	
12		23.2575	24.93	9.70	34.63	50.00	-15.37	AVG	

REMARKS:

- (1) Measurement Value = Reading Level + Correct Factor.
- (2) Margin Level = Measurement Value - Limit Value.

Test Mode	Idle	Tested Date	2024/3/21
Test Frequency	-	Phase	Neutral

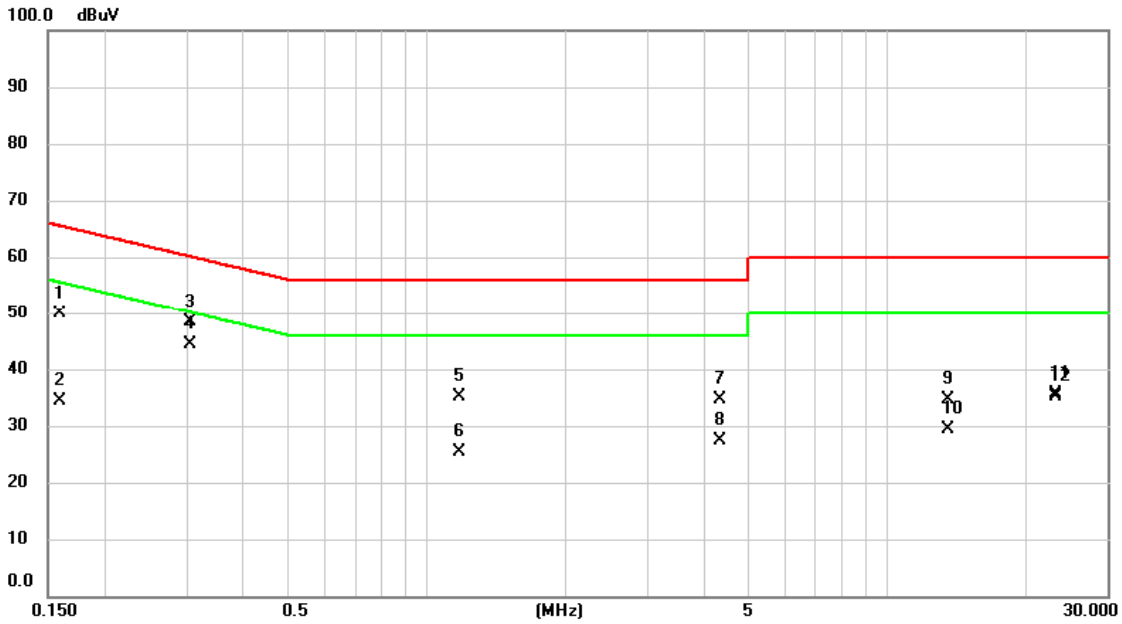

No.	Mk.	Freq. MHz	Reading Level dBuV	Correct Factor dB	Measure- ment dBuV	Limit dBuV	Margin dB	Detector	Comment
1		0.1590	40.22	9.59	49.81	65.52	-15.71	QP	
2		0.1590	24.71	9.59	34.30	55.52	-21.22	AVG	
3		0.3052	38.70	9.57	48.27	60.10	-11.83	QP	
4	*	0.3052	34.73	9.57	44.30	50.10	-5.80	AVG	
5		1.1782	25.43	9.58	35.01	56.00	-20.99	QP	
6		1.1782	15.69	9.58	25.27	46.00	-20.73	AVG	
7		4.3057	24.99	9.63	34.62	56.00	-21.38	QP	
8		4.3057	17.86	9.63	27.49	46.00	-18.51	AVG	
9		13.5600	24.92	9.77	34.69	60.00	-25.31	QP	
10		13.5600	19.63	9.77	29.40	50.00	-20.60	AVG	
11		23.2597	25.84	9.85	35.69	60.00	-24.31	QP	
12		23.2597	25.28	9.85	35.13	50.00	-14.87	AVG	

REMARKS:

(1) Measurement Value = Reading Level + Correct Factor.

(2) Margin Level = Measurement Value - Limit Value.

APPENDIX B RADIATED EMISSIONS - 9 KHZ TO 30 MHZ

Test Mode	IEEE 802.11ac (VHT80)	Test Date	2024/3/26
Test Frequency	5290MHz	Polarization	Vertical
Temp	24°C	Hum.	64%

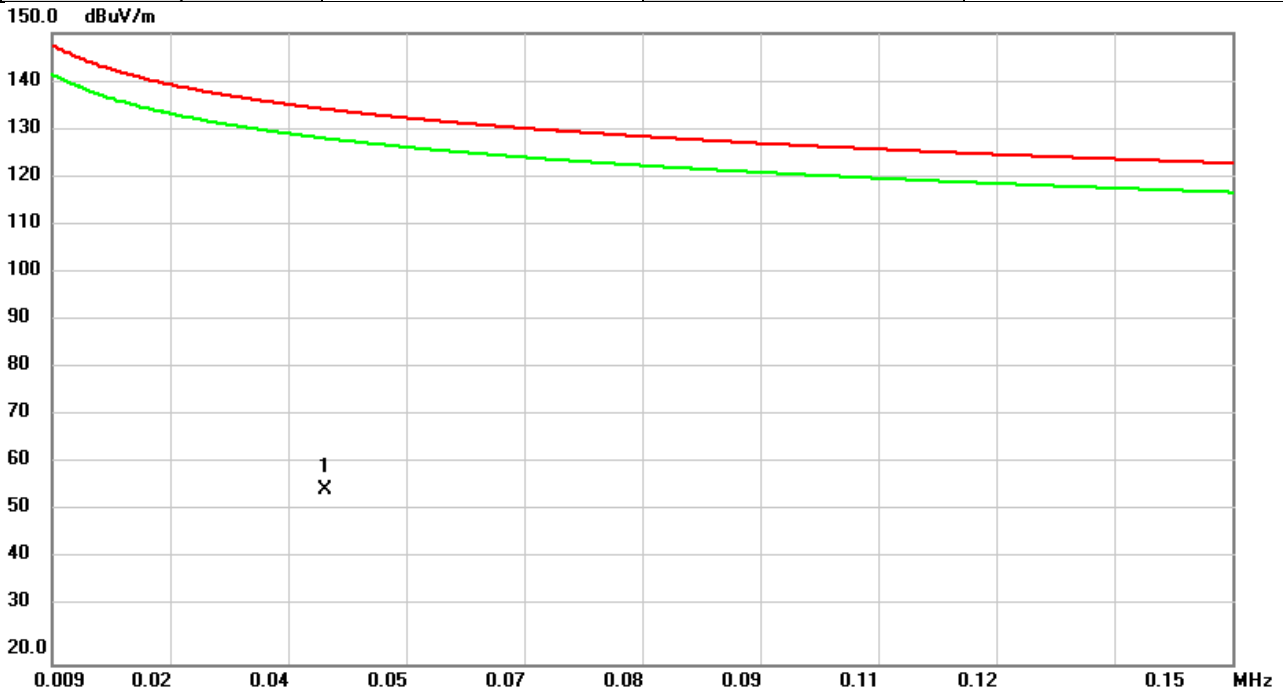

No.	Mk.	Freq.	Reading Level	Correct Factor	Measurement	Limit	Over	Detector	Comment
		MHz	dBuV	dB	dBuV/m	dBuV/m	dB		
1	*	0.0417	30.63	25.40	56.03	134.28	-78.25	QP	

REMARKS:

- (1) Measurement Value = Reading Level + Correct Factor.
- (2) Margin Level = Measurement Value - Limit Value.

Test Mode	IEEE 802.11ac (VHT80)	Test Date	2024/3/26
Test Frequency	5290MHz	Polarization	Vertical
Temp	24°C	Hum.	64%



No.	Mk.	Freq.	Reading Level	Correct Factor	Measurement	Limit	Over	Detector	Comment
		MHz	dBuV	dB	dBuV/m	dBuV/m	dB		
1	*	0.7460	70.46	3.11	73.57	89.23	-15.66	QP	
2		2.1630	63.35	-2.07	61.28	88.62	-27.34	QP	
3		7.3787	52.45	-3.81	48.64	88.62	-39.98	QP	
4		9.8711	49.57	-3.20	46.37	88.62	-42.25	QP	
5		16.0052	50.54	-3.73	46.81	88.62	-41.81	QP	
6		22.4937	60.94	-2.91	58.03	88.62	-30.59	QP	

REMARKS:

- (1) Measurement Value = Reading Level + Correct Factor.
- (2) Margin Level = Measurement Value - Limit Value.

Test Mode	IEEE 802.11ac (VHT80)	Test Date	2024/3/26
Test Frequency	5290MHz	Polarization	Horizontal
Temp	24°C	Hum.	64%

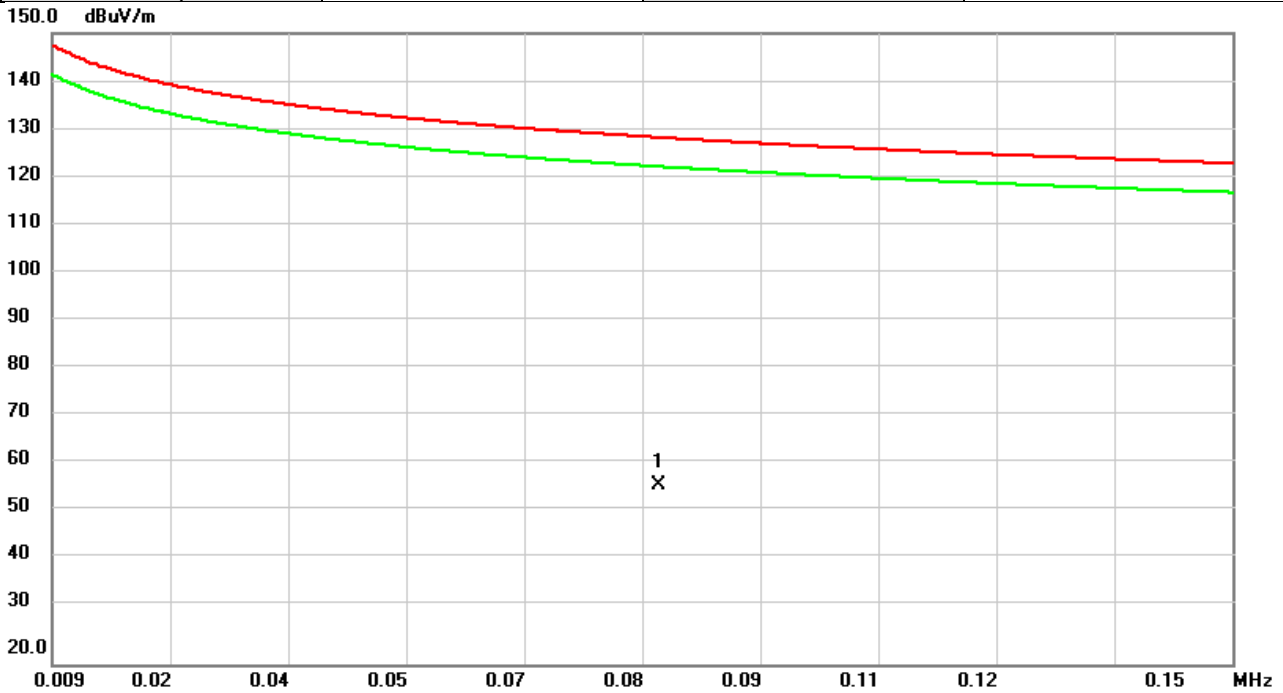

No.	Mk.	Freq.	Reading Level	Correct Factor	Measurement	Limit	Over	Detector	Comment
		MHz	dBuV	dB	dBuV/m	dBuV/m	dB		
1	*	0.0814	37.70	19.15	56.85	128.47	-71.62	QP	

REMARKS:

- (1) Measurement Value = Reading Level + Correct Factor.
- (2) Margin Level = Measurement Value - Limit Value.

Test Mode	IEEE 802.11ac (VHT80)	Test Date	2024/3/26
Test Frequency	5290MHz	Polarization	Horizontal
Temp	24°C	Hum.	64%

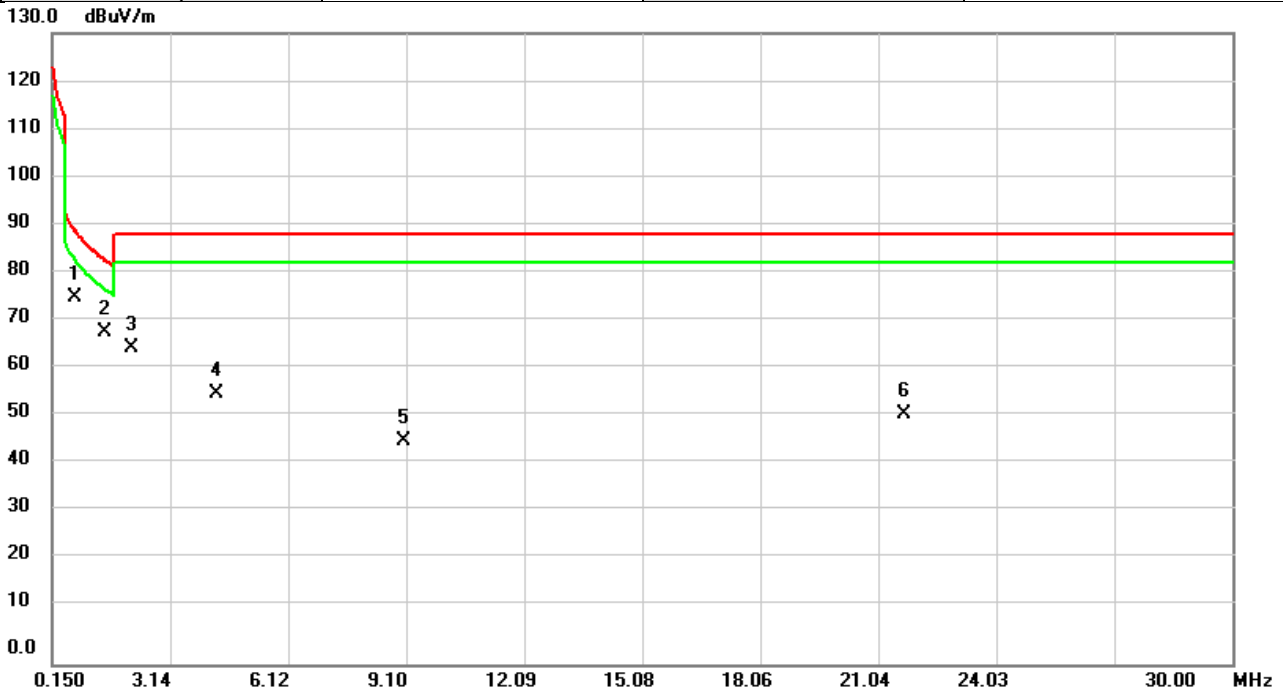

No.	Mk.	Freq.	Reading Level	Correct Factor	Measurement	Limit	Over	Detector	Comment
		MHz	dBuV	dB	dBuV/m	dBuV/m	dB		
1	*	0.7460	72.48	3.11	75.59	89.23	-13.64	QP	
2		1.4972	68.92	-0.43	68.49	83.17	-14.68	QP	
3		2.1610	67.37	-2.06	65.31	88.62	-23.31	QP	
4		4.3240	59.83	-4.19	55.64	88.62	-32.98	QP	
5		9.0483	49.44	-3.40	46.04	88.62	-42.58	QP	
6		21.7156	54.67	-3.28	51.39	88.62	-37.23	QP	

REMARKS:

- (1) Measurement Value = Reading Level + Correct Factor.
- (2) Margin Level = Measurement Value - Limit Value.

APPENDIX C RADIATED EMISSIONS - 30 MHZ TO 1 GHZ

Test Mode	IEEE 802.11ac (VHT80)	Test Date	2024/3/26
Test Frequency	5290MHz	Polarization	Vertical
Temp	24°C	Hum.	64%

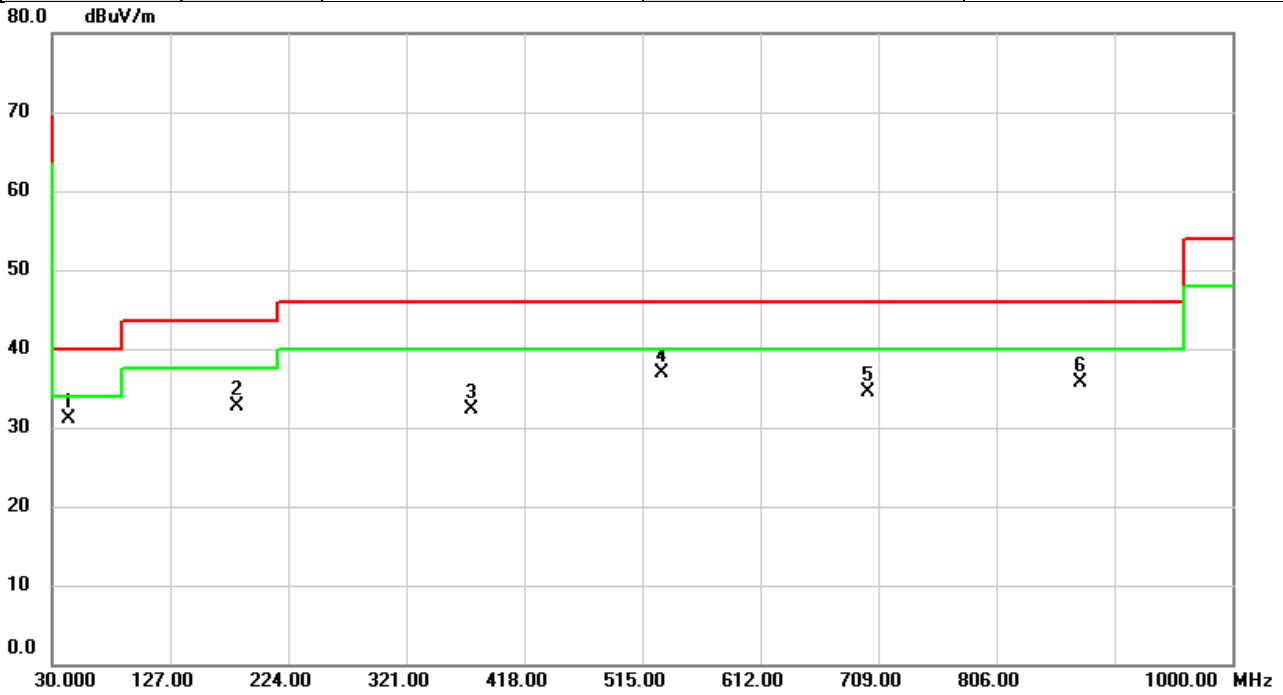

No.	Mk.	Freq.	Reading Level	Correct Factor	Measurement	Limit	Over	Detector	Comment
		MHz	dBuV	dB	dBuV/m	dBuV/m	dB		
1	*	42.9657	42.41	-11.34	31.07	40.00	-8.93	peak	
2		181.3847	46.11	-13.40	32.71	43.50	-10.79	peak	
3		374.9967	41.65	-9.40	32.25	46.00	-13.75	peak	
4		531.3283	42.89	-5.89	37.00	46.00	-9.00	peak	
5		700.5933	37.10	-2.66	34.44	46.00	-11.56	peak	
6		874.9993	35.81	-0.02	35.79	46.00	-10.21	peak	

REMARKS:

- (1) Measurement Value = Reading Level + Correct Factor.
- (2) Margin Level = Measurement Value - Limit Value.

Test Mode	IEEE 802.11ac (VHT80)	Test Date	2024/3/26
Test Frequency	5290MHz	Polarization	Horizontal
Temp	24°C	Hum.	64%

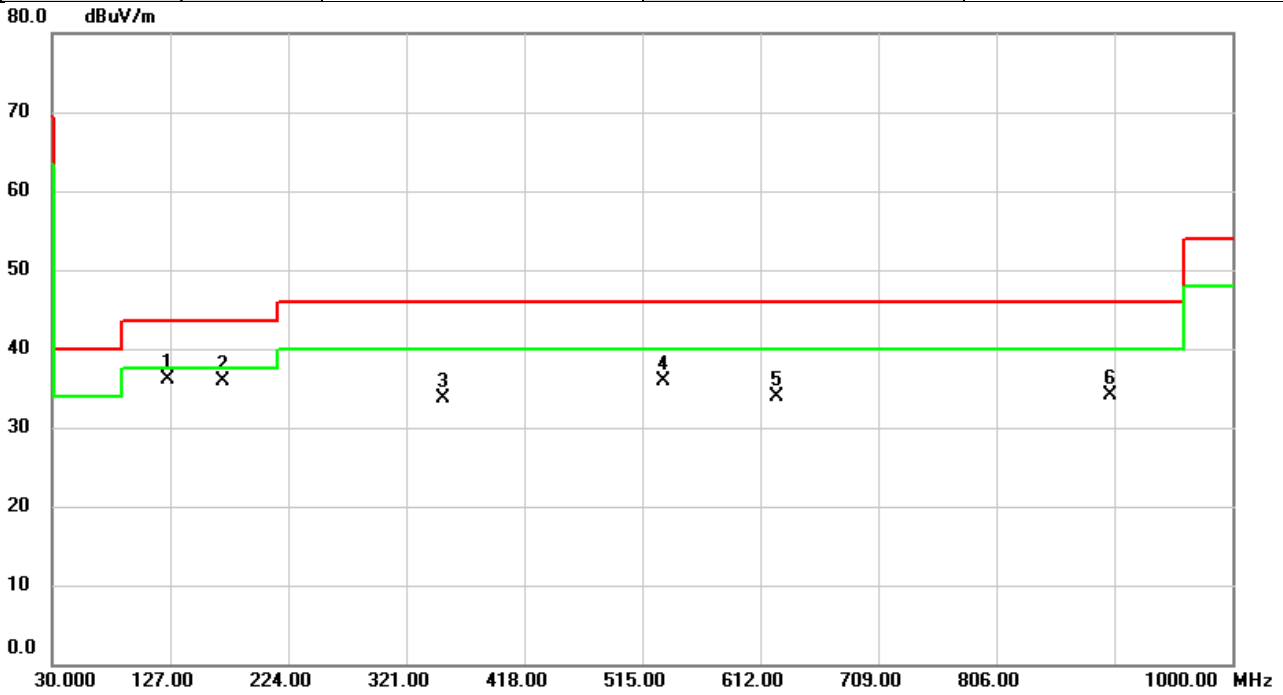

No.	Mk.	Freq.	Reading Level	Correct Factor	Measurement	Limit	Over	Detector	Comment
		MHz	dBuV	dB	dBuV/m	dBuV/m	dB		
1	*	124.9953	49.89	-13.87	36.02	43.50	-7.48	peak	
2		170.0357	48.09	-12.27	35.82	43.50	-7.68	peak	
3		351.2640	43.78	-10.16	33.62	46.00	-12.38	peak	
4		532.9450	41.67	-5.86	35.81	46.00	-10.19	peak	
5		624.9980	37.69	-3.73	33.96	46.00	-12.04	peak	
6		900.0253	33.96	0.17	34.13	46.00	-11.87	peak	

REMARKS:

- (1) Measurement Value = Reading Level + Correct Factor.
- (2) Margin Level = Measurement Value - Limit Value.

APPENDIX D RADIATED EMISSIONS - ABOVE 1 GHZ

Test Mode	IEEE 802.11a	Test Date	2024/3/25
Test Frequency	5180MHz	Polarization	Horizontal
Temp	26°C	Hum.	57%

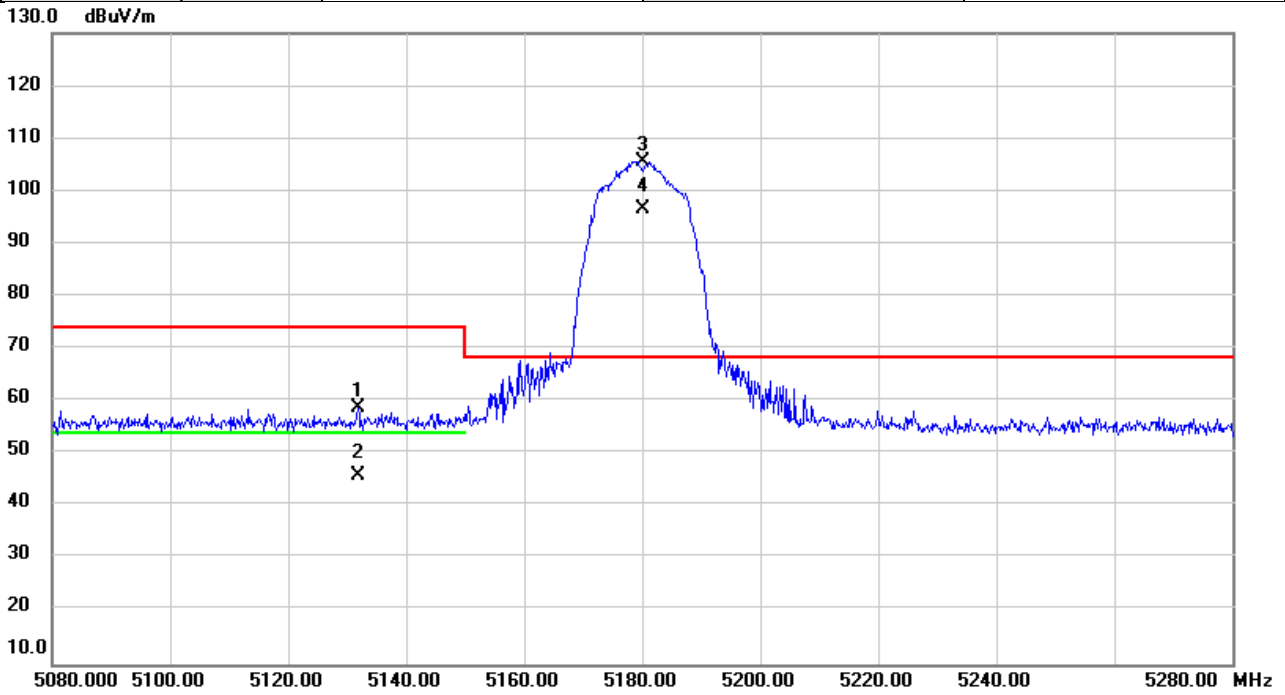

No.	Mk.	Freq.	Reading Level	Correct Factor	Measurement	Limit	Over	Detector	Comment
		MHz	dBuV	dB	dBuV/m	dBuV/m	dB		
1		5131.793	57.34	1.46	58.80	74.00	-15.20	peak	
2		5131.793	44.53	1.46	45.99	54.00	-8.01	AVG	
3	*	5180.000	104.17	1.49	105.66	68.20	37.46	peak	NoLimit
4	X	5180.000	95.17	1.49	96.66	68.20	28.46	AVG	NoLimit

REMARKS:

- (1) Measurement Value = Reading Level + Correct Factor.
- (2) Margin Level = Measurement Value - Limit Value.

Test Mode	IEEE 802.11a	Test Date	2024/3/25
Test Frequency	5240MHz	Polarization	Horizontal
Temp	26°C	Hum.	57%

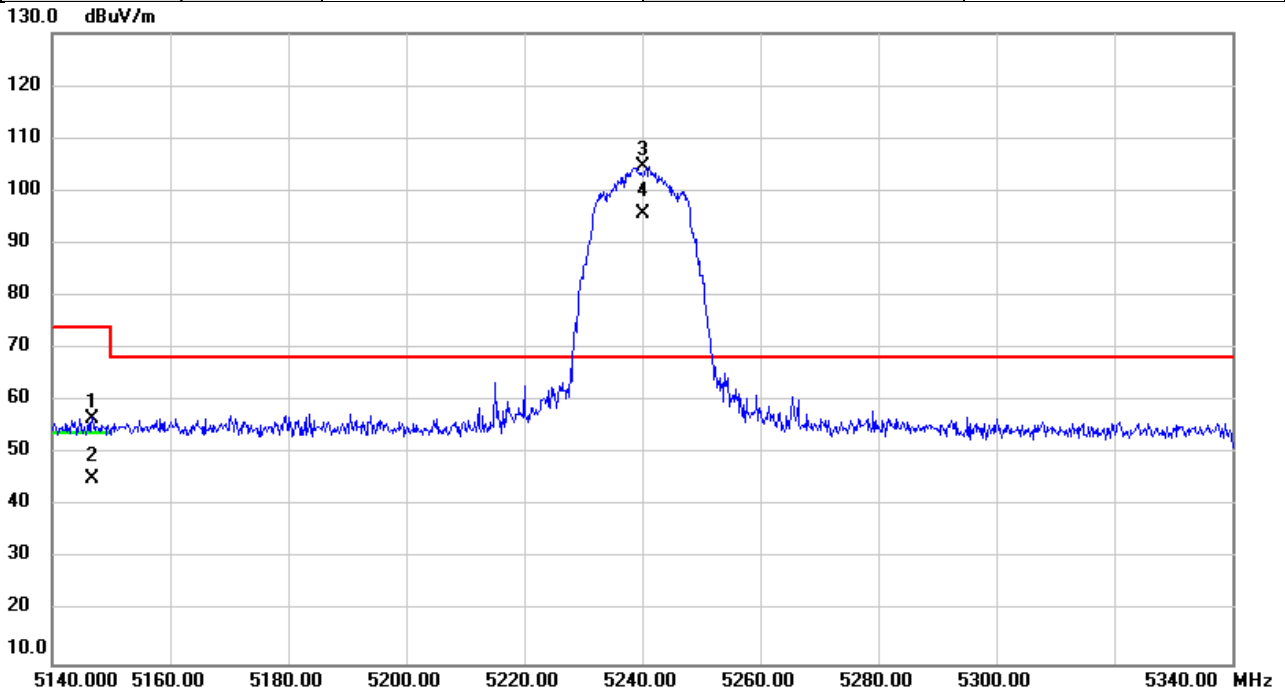

No.	Mk.	Freq.	Reading Level	Correct Factor	Measurement	Limit	Over	Detector	Comment
		MHz	dBuV	dB	dBuV/m	dBuV/m	dB		
1		5146.813	55.33	1.47	56.80	74.00	-17.20	peak	
2		5146.813	43.68	1.47	45.15	54.00	-8.85	AVG	
3	*	5240.000	103.13	1.53	104.66	68.20	36.46	peak	NoLimit
4	X	5240.000	94.09	1.53	95.62	68.20	27.42	AVG	NoLimit

REMARKS:

- (1) Measurement Value = Reading Level + Correct Factor.
- (2) Margin Level = Measurement Value - Limit Value.

Test Mode	IEEE 802.11a	Test Date	2024/3/25
Test Frequency	5260MHz	Polarization	Horizontal
Temp	26°C	Hum.	57%

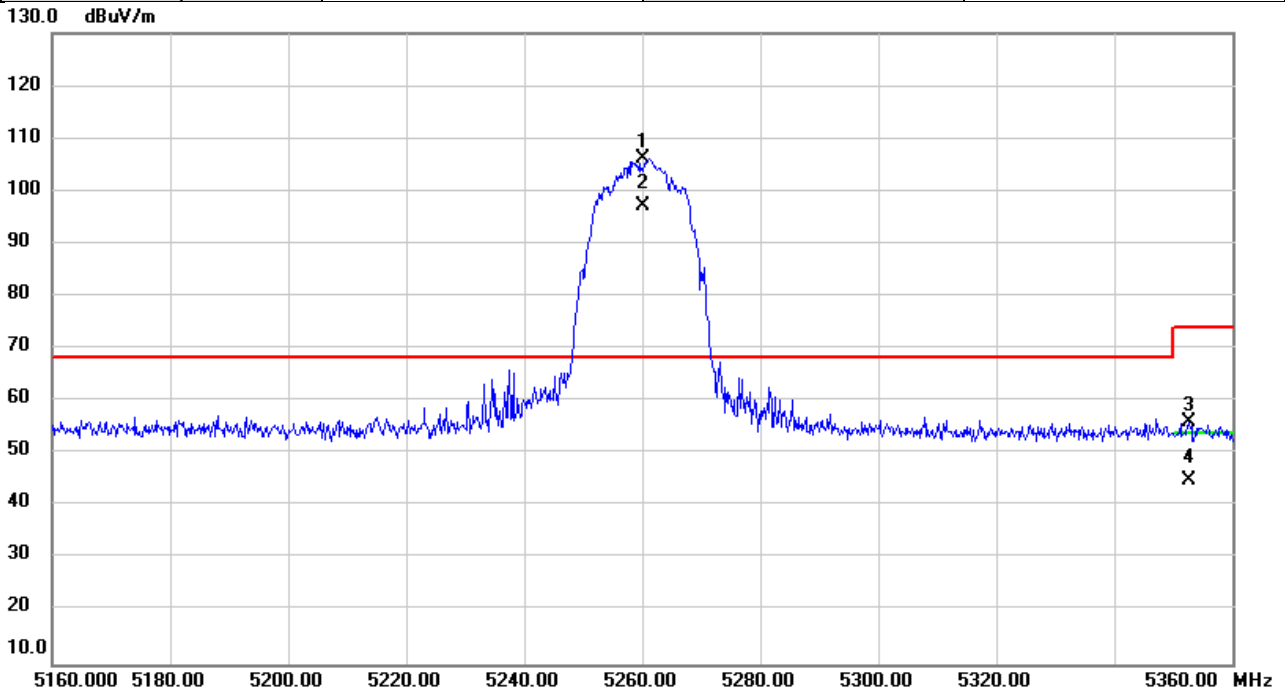

No.	Mk.	Freq.	Reading Level	Correct Factor	Measurement	Limit	Over	Detector	Comment
		MHz	dBuV	dB	dBuV/m	dBuV/m	dB		
1	*	5260.000	104.58	1.54	106.12	68.20	37.92	peak	NoLimit
2	X	5260.000	95.51	1.54	97.05	68.20	28.85	AVG	NoLimit
3		5352.607	54.51	1.60	56.11	74.00	-17.89	peak	
4		5352.607	43.45	1.60	45.05	54.00	-8.95	AVG	

REMARKS:

- (1) Measurement Value = Reading Level + Correct Factor.
- (2) Margin Level = Measurement Value - Limit Value.

Test Mode	IEEE 802.11a	Test Date	2024/3/25
Test Frequency	5320MHz	Polarization	Horizontal
Temp	26°C	Hum.	57%

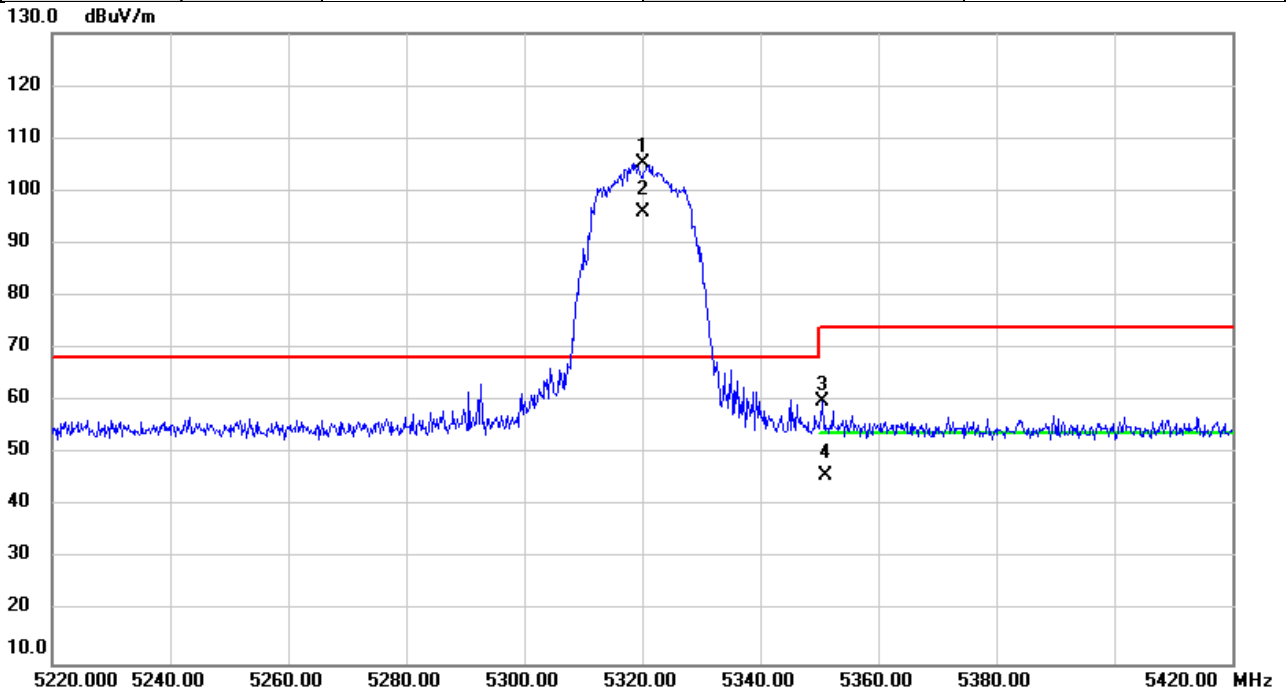

No.	Mk.	Freq.	Reading Level	Correct Factor	Measurement	Limit	Over	Detector	Comment
		MHz	dBuV	dB	dBuV/m	dBuV/m	dB		
1	*	5320.000	103.65	1.58	105.23	68.20	37.03	peak	NoLimit
2	X	5320.000	94.51	1.58	96.09	68.20	27.89	AVG	NoLimit
3		5350.487	58.25	1.60	59.85	74.00	-14.15	peak	
4		5351.090	44.37	1.60	45.97	54.00	-8.03	AVG	

REMARKS:

- (1) Measurement Value = Reading Level + Correct Factor.
- (2) Margin Level = Measurement Value - Limit Value.

Test Mode	IEEE 802.11a	Test Date	2024/3/25
Test Frequency	5500MHz	Polarization	Horizontal
Temp	26°C	Hum.	57%

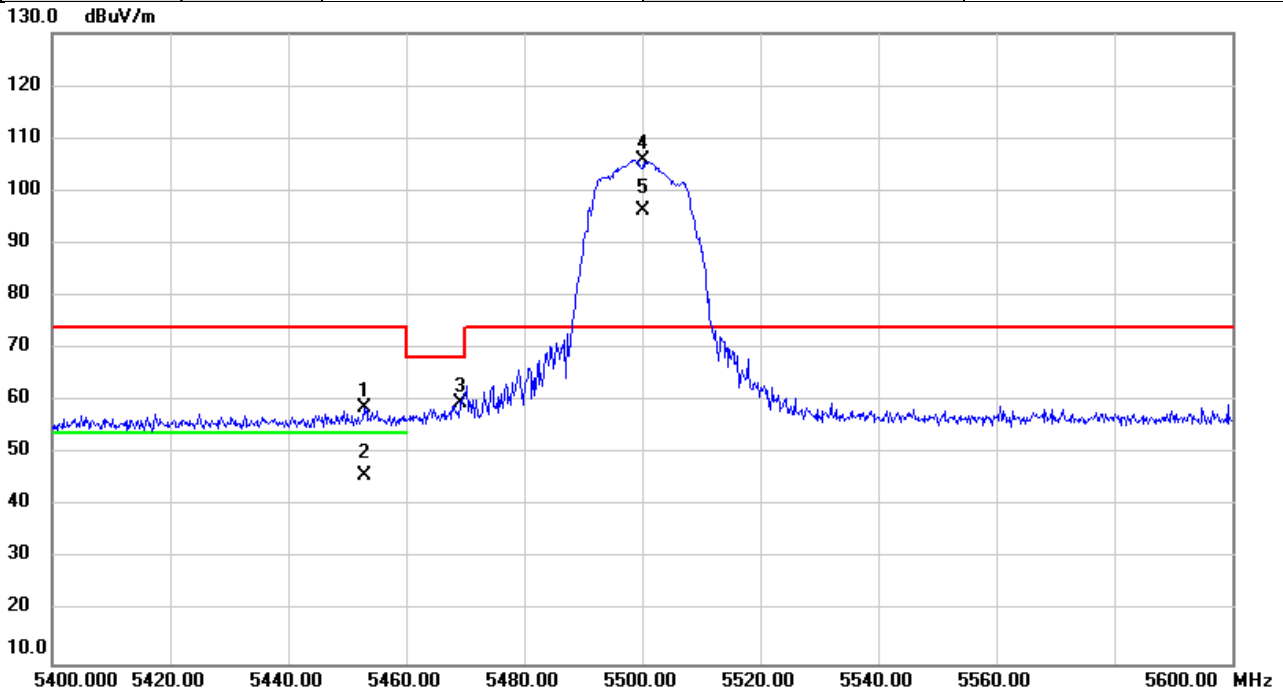

No.	Mk.	Freq.	Reading Level	Correct Factor	Measurement	Limit	Over	Detector	Comment
		MHz	dBuV	dB	dBuV/m	dBuV/m	dB		
1		5452.833	57.08	1.65	58.73	74.00	-15.27	peak	
2		5452.833	44.15	1.65	45.80	54.00	-8.20	AVG	
3		5469.140	57.85	1.66	59.51	68.20	-8.69	peak	
4	*	5500.000	104.16	1.68	105.84	74.00	31.84	peak	NoLimit
5	X	5500.000	94.48	1.68	96.16	74.00	22.16	AVG	NoLimit

REMARKS:

- (1) Measurement Value = Reading Level + Correct Factor.
- (2) Margin Level = Measurement Value - Limit Value.

Test Mode	IEEE 802.11a	Test Date	2024/3/25
Test Frequency	5700MHz	Polarization	Horizontal
Temp	26°C	Hum.	57%

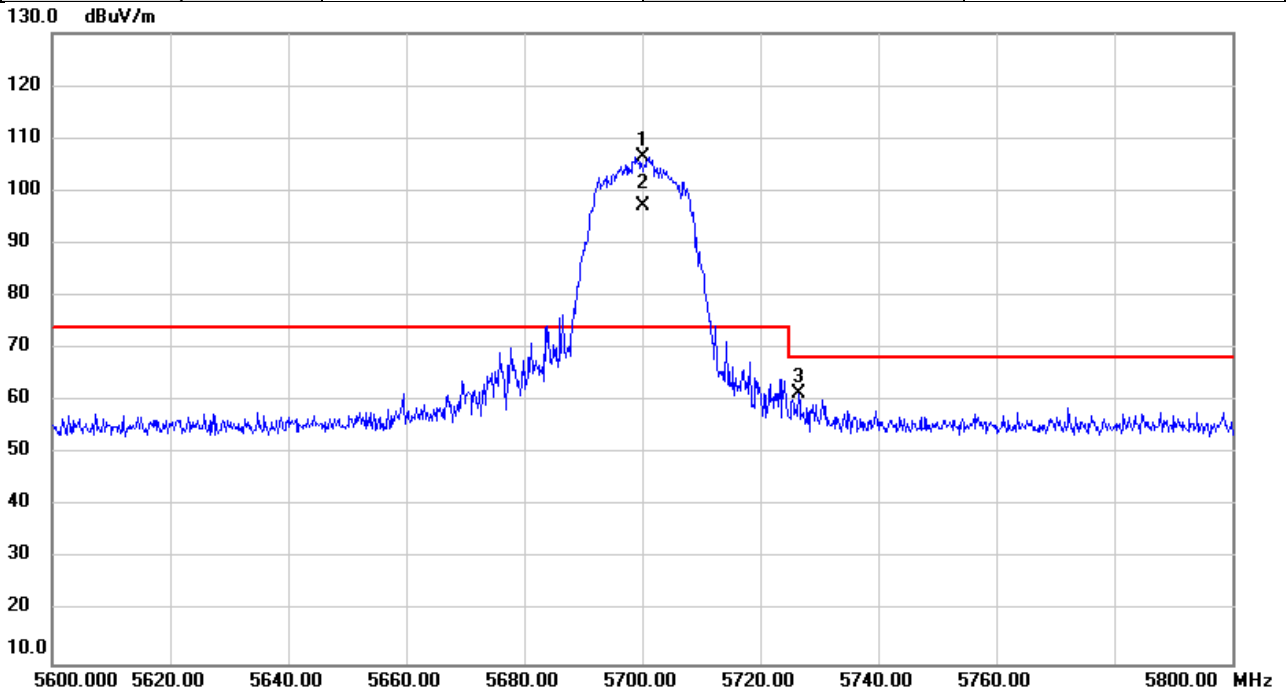

No.	Mk.	Freq.	Reading Level	Correct Factor	Measurement	Limit	Over		
		MHz	dBuV	dB	dBuV/m	dBuV/m	dB	Detector	Comment
1	*	5700.000	104.13	2.26	106.39	74.00	32.39	peak	NoLimit
2	X	5700.000	94.77	2.26	97.03	74.00	23.03	AVG	NoLimit
3		5726.467	59.19	2.34	61.53	68.20	-6.67	peak	

REMARKS:

- (1) Measurement Value = Reading Level + Correct Factor.
- (2) Margin Level = Measurement Value - Limit Value.

Test Mode	IEEE 802.11a	Test Date	2024/3/25
Test Frequency	5745MHz	Polarization	Horizontal
Temp	26°C	Hum.	57%

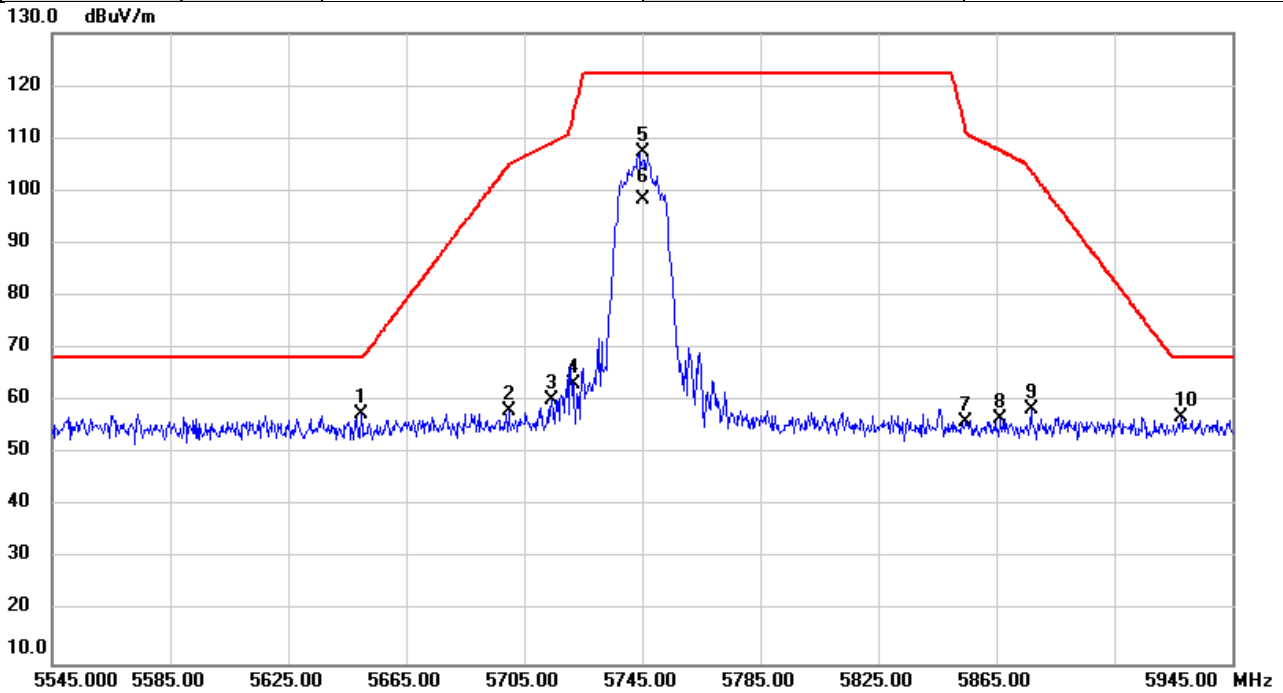

No.	Mk.	Freq.	Reading Level	Correct Factor	Measurement	Limit	Over	Detector	Comment
		MHz	dBuV	dB	dBuV/m	dBuV/m	dB		
1	*	5649.707	55.55	2.12	57.67	68.20	-10.53	peak	
2		5699.760	55.84	2.26	58.10	105.02	-46.92	peak	
3		5714.173	58.03	2.30	60.33	109.17	-48.84	peak	
4		5721.573	60.92	2.32	63.24	114.39	-51.15	peak	
5		5745.000	104.89	2.38	107.27	122.20	-14.93	peak	NoLimit
6		5745.000	95.89	2.38	98.27	122.20	-23.93	AVG	NoLimit
7		5854.853	53.29	2.70	55.99	111.14	-55.15	peak	
8		5866.293	53.87	2.73	56.60	107.64	-51.04	peak	
9		5876.773	55.56	2.77	58.33	103.88	-45.55	peak	
10		5927.547	54.07	2.91	56.98	68.20	-11.22	peak	

REMARKS:

- (1) Measurement Value = Reading Level + Correct Factor.
- (2) Margin Level = Measurement Value - Limit Value.

Test Mode	IEEE 802.11a	Test Date	2024/3/25
Test Frequency	5825MHz	Polarization	Horizontal
Temp	26°C	Hum.	57%

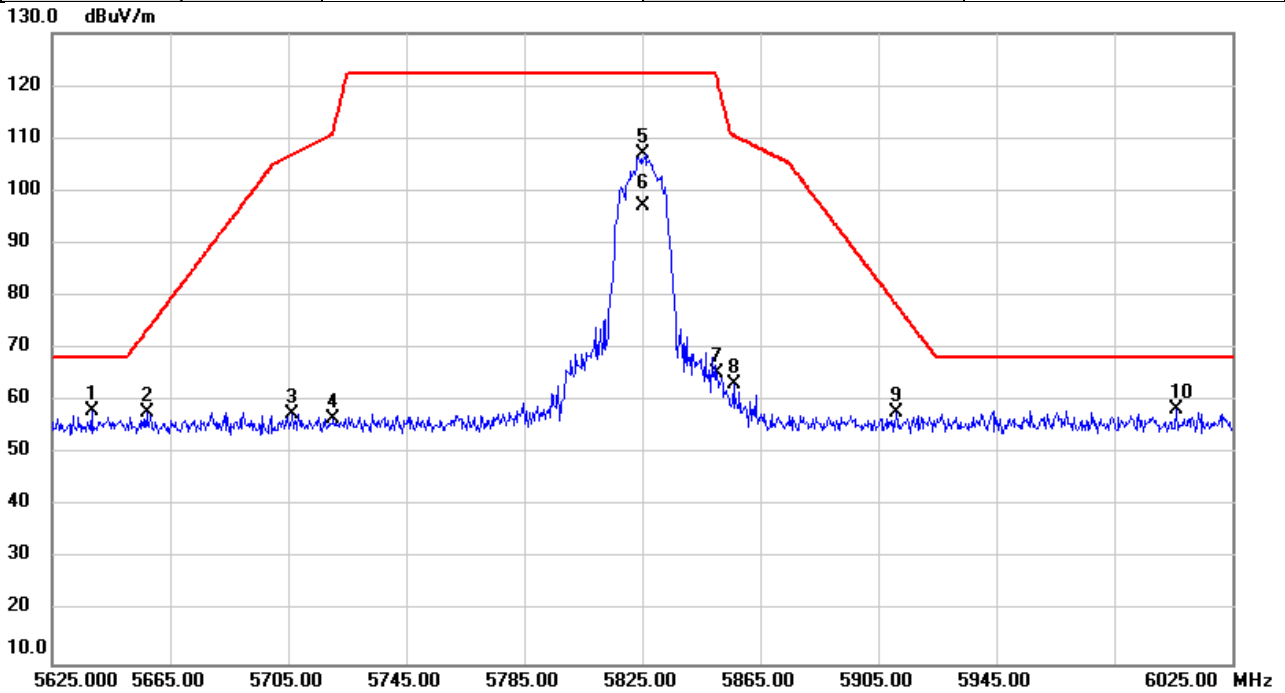

No.	Mk.	Freq.	Reading Level	Correct Factor	Measurement	Limit	Over	Detector	Comment
		MHz	dBuV	dB	dBuV/m	dBuV/m	dB		
1		5638.520	56.14	2.08	58.22	68.20	-9.98	peak	
2		5657.173	55.85	2.13	57.98	73.53	-15.55	peak	
3		5706.360	55.31	2.27	57.58	106.98	-49.40	peak	
4		5720.227	54.34	2.32	56.66	111.32	-54.66	peak	
5		5825.000	104.55	2.61	107.16	122.20	-15.04	peak	NoLimit
6		5825.000	94.62	2.61	97.23	122.20	-24.97	AVG	NoLimit
7		5850.227	62.68	2.68	65.36	121.68	-56.32	peak	
8		5856.053	60.64	2.70	63.34	110.50	-47.16	peak	
9		5911.160	54.87	2.87	57.74	78.41	-20.67	peak	
10	*	6006.173	55.23	3.16	58.39	68.20	-9.81	peak	

REMARKS:

- (1) Measurement Value = Reading Level + Correct Factor.
- (2) Margin Level = Measurement Value - Limit Value.

Test Mode	IEEE 802.11n (HT20)	Test Date	2024/3/25
Test Frequency	5180MHz	Polarization	Horizontal
Temp	26°C	Hum.	57%

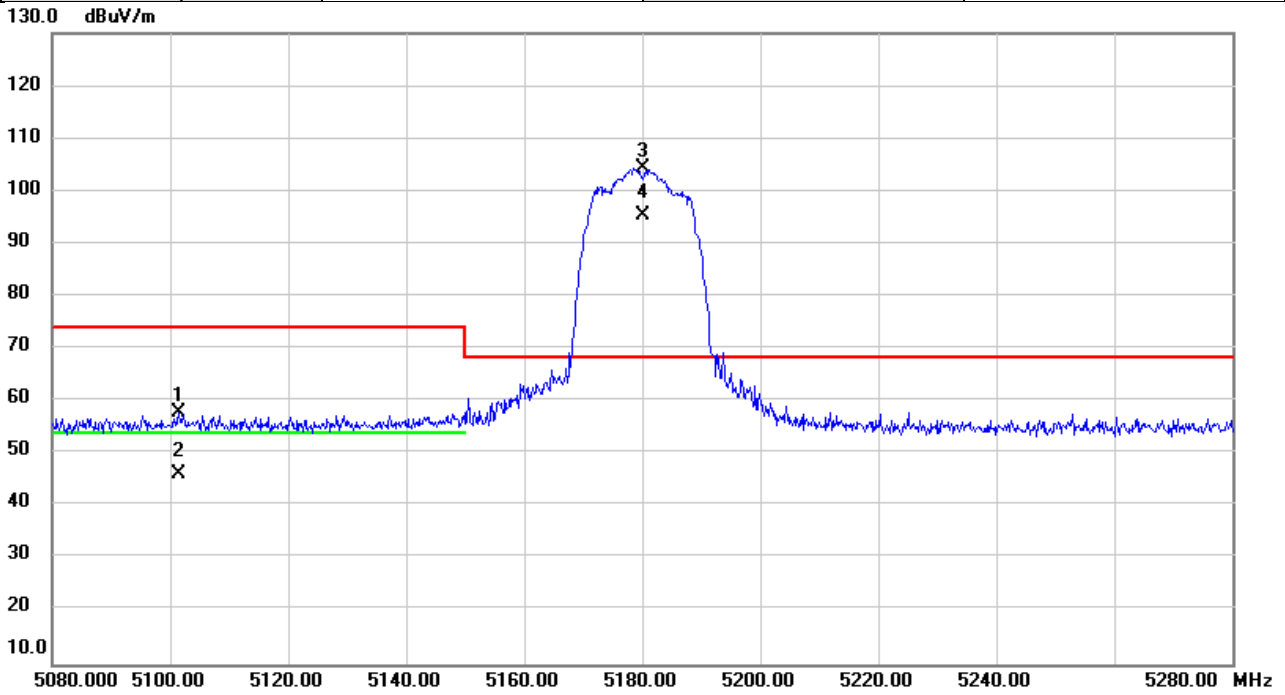

No.	Mk.	Freq.	Reading Level	Correct Factor	Measurement	Limit	Over	Detector	Comment
		MHz	dBuV	dB	dBuV/m	dBuV/m	dB		
1		5101.507	56.44	1.45	57.89	74.00	-16.11	peak	
2		5101.507	44.79	1.45	46.24	54.00	-7.76	AVG	
3	*	5180.000	102.91	1.49	104.40	68.20	36.20	peak	NoLimit
4	X	5180.000	93.79	1.49	95.28	68.20	27.08	AVG	NoLimit

REMARKS:

- (1) Measurement Value = Reading Level + Correct Factor.
- (2) Margin Level = Measurement Value - Limit Value.

Test Mode	IEEE 802.11n (HT20)	Test Date	2024/3/25
Test Frequency	5240MHz	Polarization	Horizontal
Temp	26°C	Hum.	57%

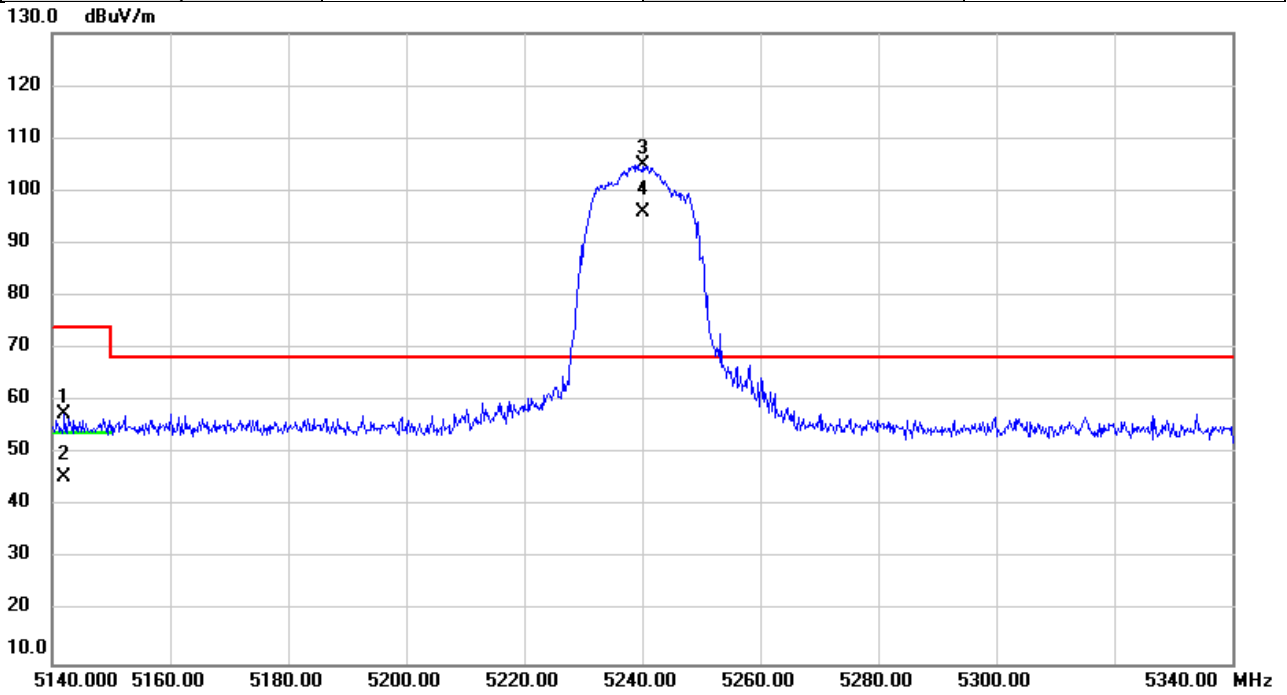

No.	Mk.	Freq.	Reading Level	Correct Factor	Measurement	Limit	Over	Detector	Comment
		MHz	dBuV	dB	dBuV/m	dBuV/m	dB		
1		5142.093	56.16	1.47	57.63	74.00	-16.37	peak	
2		5142.093	44.08	1.47	45.55	54.00	-8.45	AVG	
3	*	5240.000	103.52	1.53	105.05	68.20	36.85	peak	NoLimit
4	X	5240.000	94.43	1.53	95.96	68.20	27.76	AVG	NoLimit

REMARKS:

- (1) Measurement Value = Reading Level + Correct Factor.
- (2) Margin Level = Measurement Value - Limit Value.

Test Mode	IEEE 802.11n (HT20)	Test Date	2024/3/26
Test Frequency	5260MHz	Polarization	Horizontal
Temp	24°C	Hum.	64%

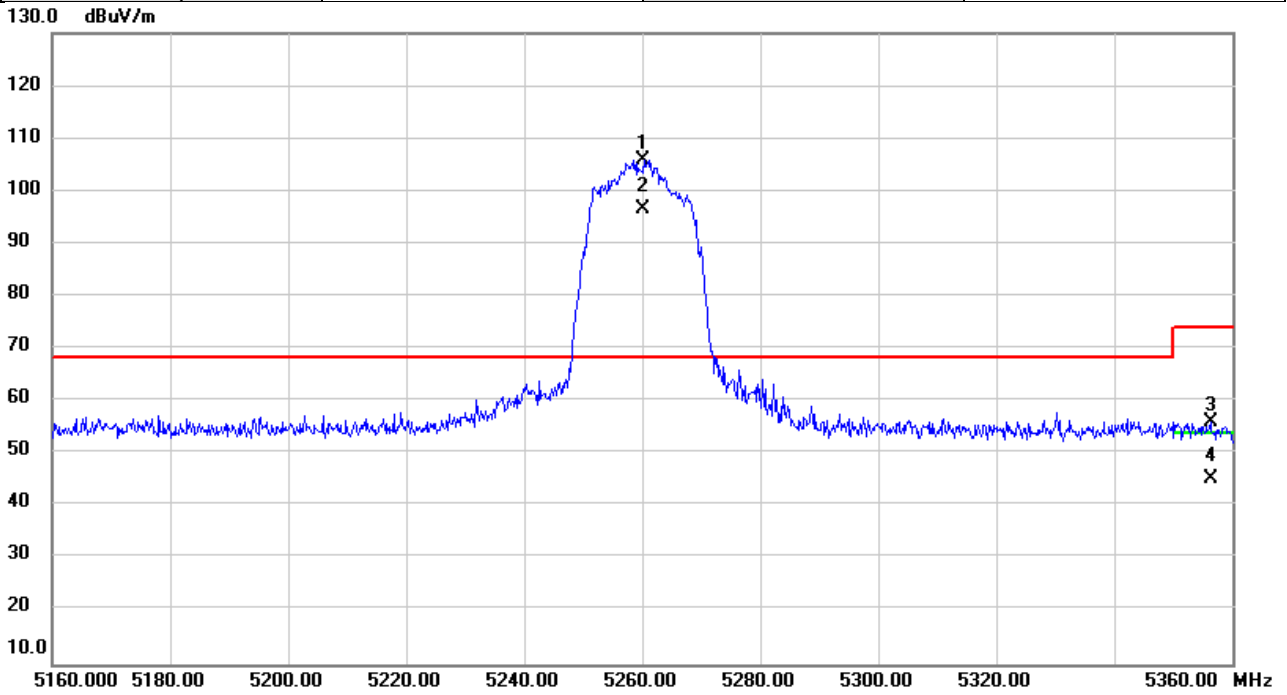

No.	Mk.	Freq.	Reading Level	Correct Factor	Measurement	Limit	Over	Detector	Comment
		MHz	dBuV	dB	dBuV/m	dBuV/m	dB		
1	*	5260.000	104.43	1.54	105.97	68.20	37.77	peak	NoLimit
2	X	5260.000	95.01	1.54	96.55	68.20	28.35	AVG	NoLimit
3		5356.380	54.36	1.60	55.96	74.00	-18.04	peak	
4		5356.380	43.77	1.60	45.37	54.00	-8.63	AVG	

REMARKS:

- (1) Measurement Value = Reading Level + Correct Factor.
- (2) Margin Level = Measurement Value - Limit Value.

Test Mode	IEEE 802.11n (HT20)	Test Date	2024/3/26
Test Frequency	5320MHz	Polarization	Horizontal
Temp	24°C	Hum.	64%

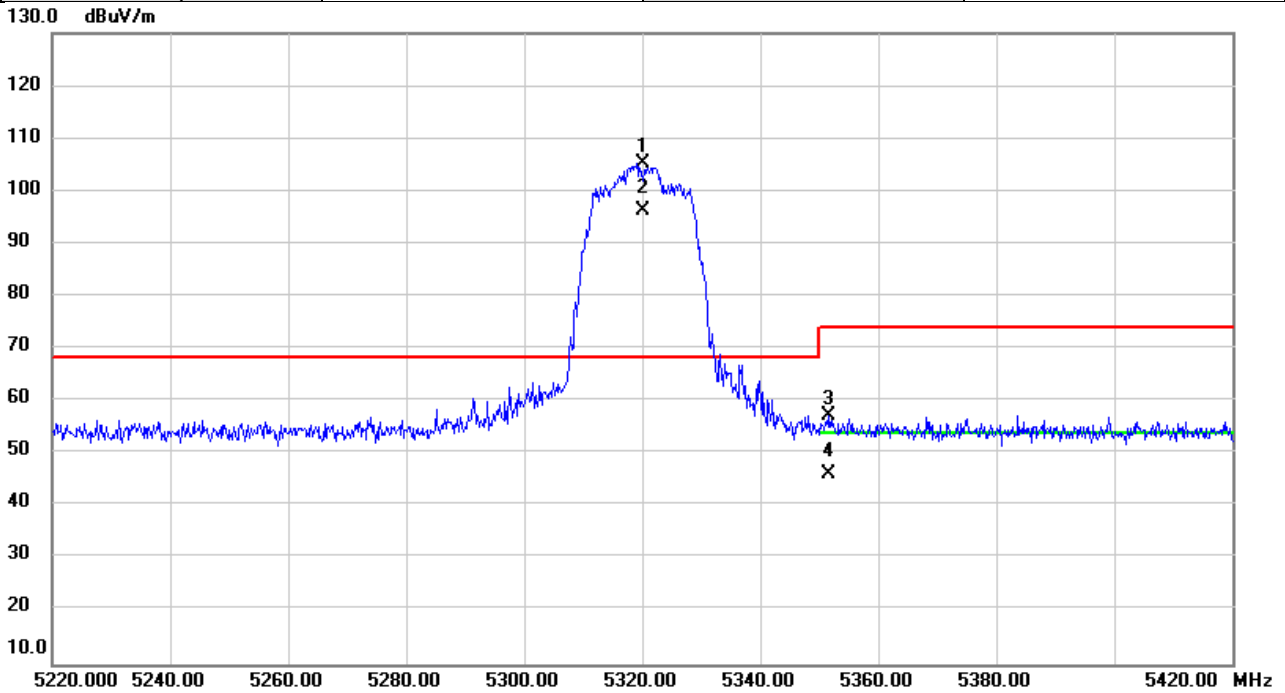

No.	Mk.	Freq.	Reading Level	Correct Factor	Measurement	Limit	Over	Detector	Comment
		MHz	dBuV	dB	dBuV/m	dBuV/m	dB		
1	*	5320.000	103.75	1.58	105.33	68.20	37.13	peak	NoLimit
2	X	5320.000	94.60	1.58	96.18	68.20	27.98	AVG	NoLimit
3		5351.640	55.65	1.60	57.25	74.00	-16.75	peak	
4		5351.640	44.57	1.60	46.17	54.00	-7.83	AVG	

REMARKS:

- (1) Measurement Value = Reading Level + Correct Factor.
- (2) Margin Level = Measurement Value - Limit Value.

Test Mode	IEEE 802.11n (HT20)	Test Date	2024/3/26
Test Frequency	5500MHz	Polarization	Horizontal
Temp	24°C	Hum.	64%

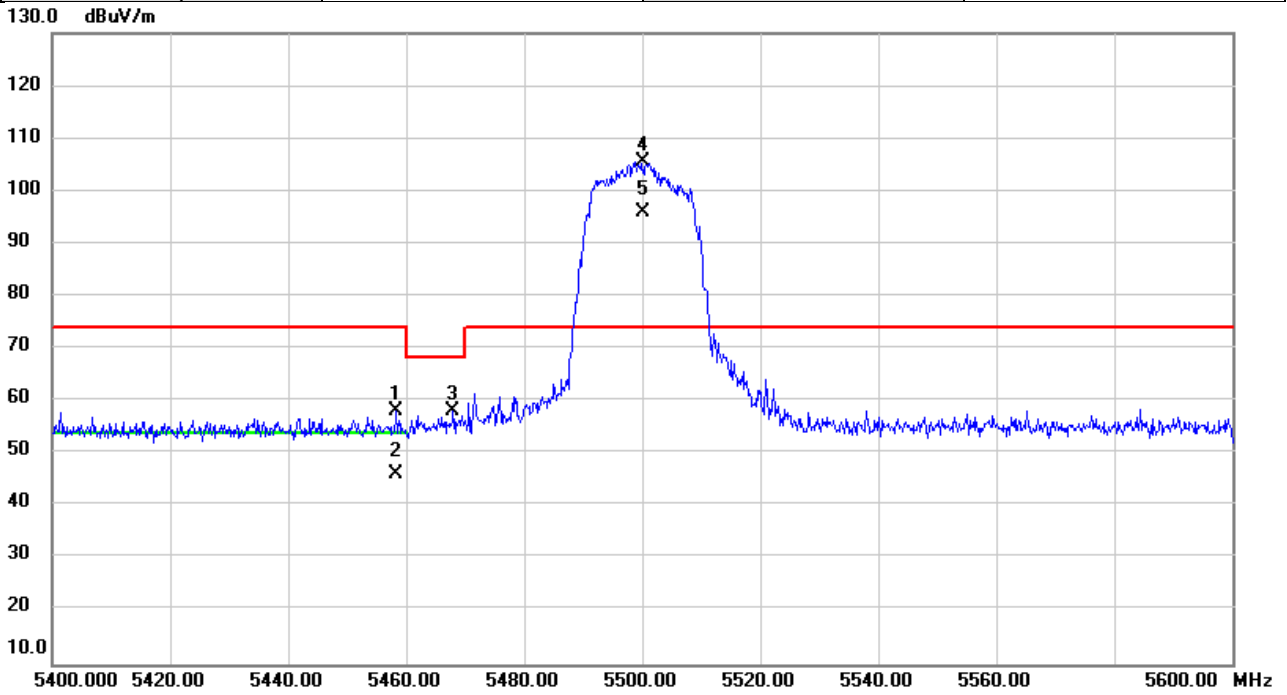

No.	Mk.	Freq.	Reading Level	Correct Factor	Measurement	Limit	Over	Detector	Comment
		MHz	dBuV	dB	dBuV/m	dBuV/m	dB		
1		5458.340	56.62	1.65	58.27	74.00	-15.73	peak	
2		5458.340	44.40	1.65	46.05	54.00	-7.95	AVG	
3		5467.820	56.39	1.66	58.05	68.20	-10.15	peak	
4	*	5500.000	103.92	1.68	105.60	74.00	31.60	peak	NoLimit
5	X	5500.000	94.41	1.68	96.09	74.00	22.09	AVG	NoLimit

REMARKS:

- (1) Measurement Value = Reading Level + Correct Factor.
- (2) Margin Level = Measurement Value - Limit Value.

Test Mode	IEEE 802.11n (HT20)	Test Date	2024/3/26
Test Frequency	5700MHz	Polarization	Horizontal
Temp	24°C	Hum.	64%

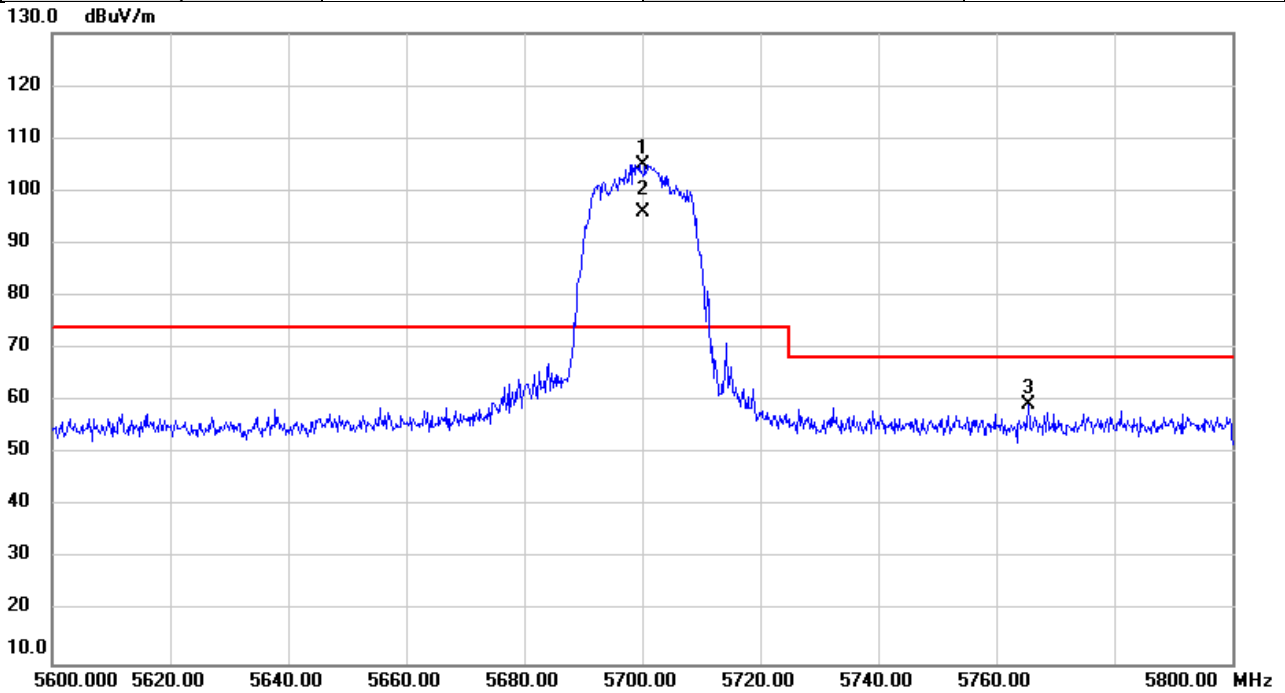

No.	Mk.	Freq.	Reading Level	Correct Factor	Measurement	Limit	Over	Detector	Comment
		MHz	dBuV	dB	dBuV/m	dBuV/m	dB		
1	*	5700.000	102.81	2.26	105.07	74.00	31.07	peak	NoLimit
2	X	5700.000	93.56	2.26	95.82	74.00	21.82	AVG	NoLimit
3		5765.513	56.89	2.45	59.34	68.20	-8.86	peak	

REMARKS:

- (1) Measurement Value = Reading Level + Correct Factor.
- (2) Margin Level = Measurement Value - Limit Value.

Test Mode	IEEE 802.11n (HT20)	Test Date	2024/3/26
Test Frequency	5745MHz	Polarization	Horizontal
Temp	24°C	Hum.	64%

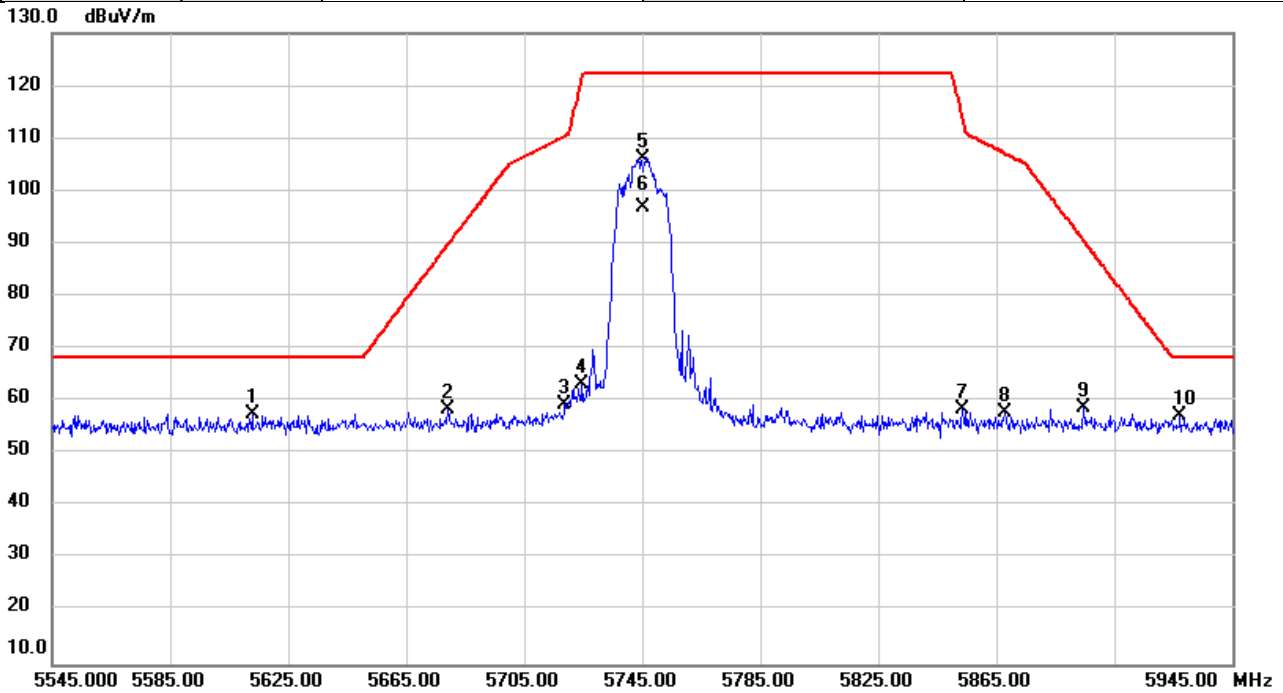

No.	Mk.	Freq.	Reading Level	Correct Factor	Measurement	Limit	Over	Detector	Comment
		MHz	dBuV	dB	dBuV/m	dBuV/m	dB		
1	*	5612.773	55.68	2.00	57.68	68.20	-10.52	peak	
2		5679.387	56.37	2.20	58.57	89.99	-31.42	peak	
3		5718.640	57.02	2.31	59.33	110.42	-51.09	peak	
4		5724.720	60.81	2.32	63.13	121.56	-58.43	peak	
5		5745.000	103.92	2.38	106.30	122.20	-15.90	peak	NoLimit
6		5745.000	94.33	2.38	96.71	122.20	-25.49	AVG	NoLimit
7		5853.573	55.76	2.70	58.46	114.05	-55.59	peak	
8		5868.200	55.18	2.73	57.91	107.10	-49.19	peak	
9		5894.587	55.84	2.82	58.66	90.67	-32.01	peak	
10		5927.200	54.47	2.91	57.38	68.20	-10.82	peak	

REMARKS:

- (1) Measurement Value = Reading Level + Correct Factor.
- (2) Margin Level = Measurement Value - Limit Value.

Test Mode	IEEE 802.11n (HT20)	Test Date	2024/3/26
Test Frequency	5825MHz	Polarization	Horizontal
Temp	24°C	Hum.	64%

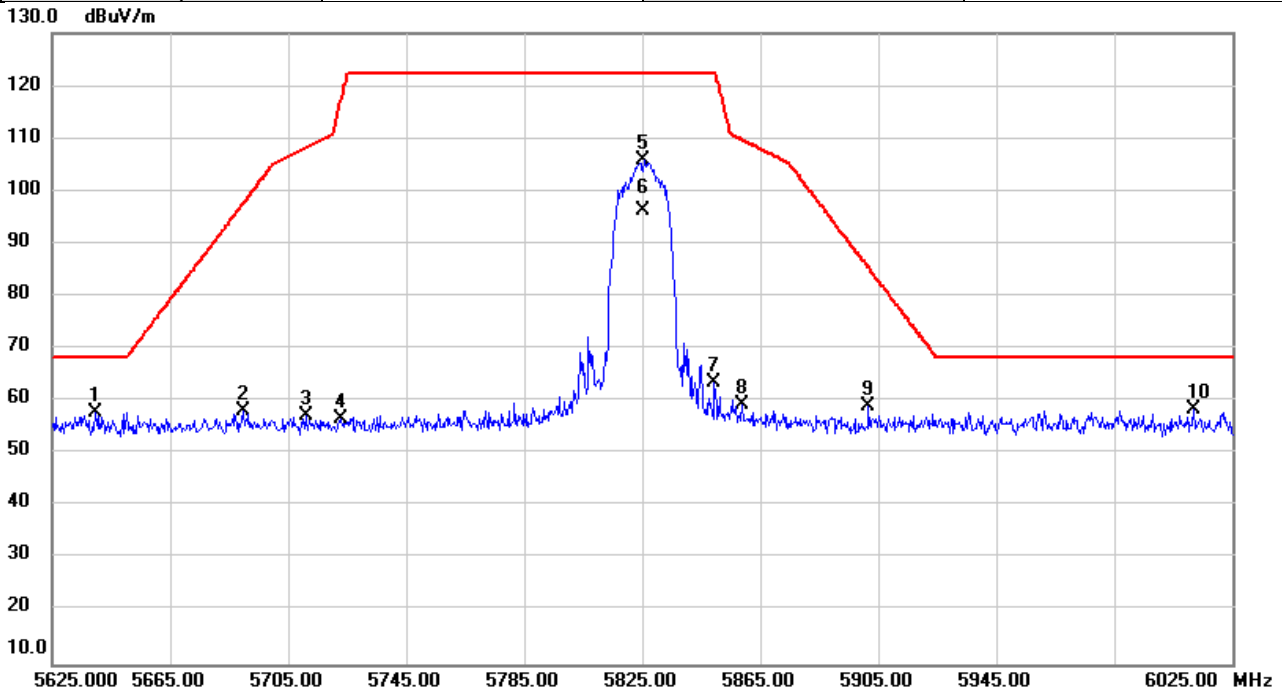

No.	Mk.	Freq.	Reading Level	Correct Factor	Measurement	Limit	Over	Detector	Comment
		MHz	dBuV	dB	dBuV/m	dBuV/m	dB		
1		5639.493	55.85	2.09	57.94	68.20	-10.26	peak	
2		5689.787	55.81	2.23	58.04	97.67	-39.63	peak	
3		5710.933	54.84	2.29	57.13	108.26	-51.13	peak	
4		5722.840	54.24	2.32	56.56	117.28	-60.72	peak	
5		5825.000	103.11	2.61	105.72	122.20	-16.48	peak	NoLimit
6		5825.000	93.70	2.61	96.31	122.20	-25.89	AVG	NoLimit
7		5849.520	60.87	2.68	63.55	122.20	-58.65	peak	
8		5859.000	56.63	2.71	59.34	109.68	-50.34	peak	
9		5901.587	56.30	2.84	59.14	85.49	-26.35	peak	
10	*	6011.933	55.13	3.19	58.32	68.20	-9.88	peak	

REMARKS:

- (1) Measurement Value = Reading Level + Correct Factor.
- (2) Margin Level = Measurement Value - Limit Value.

Test Mode	IEEE 802.11n (HT40)	Test Date	2024/3/26
Test Frequency	5190MHz	Polarization	Horizontal
Temp	24°C	Hum.	64%

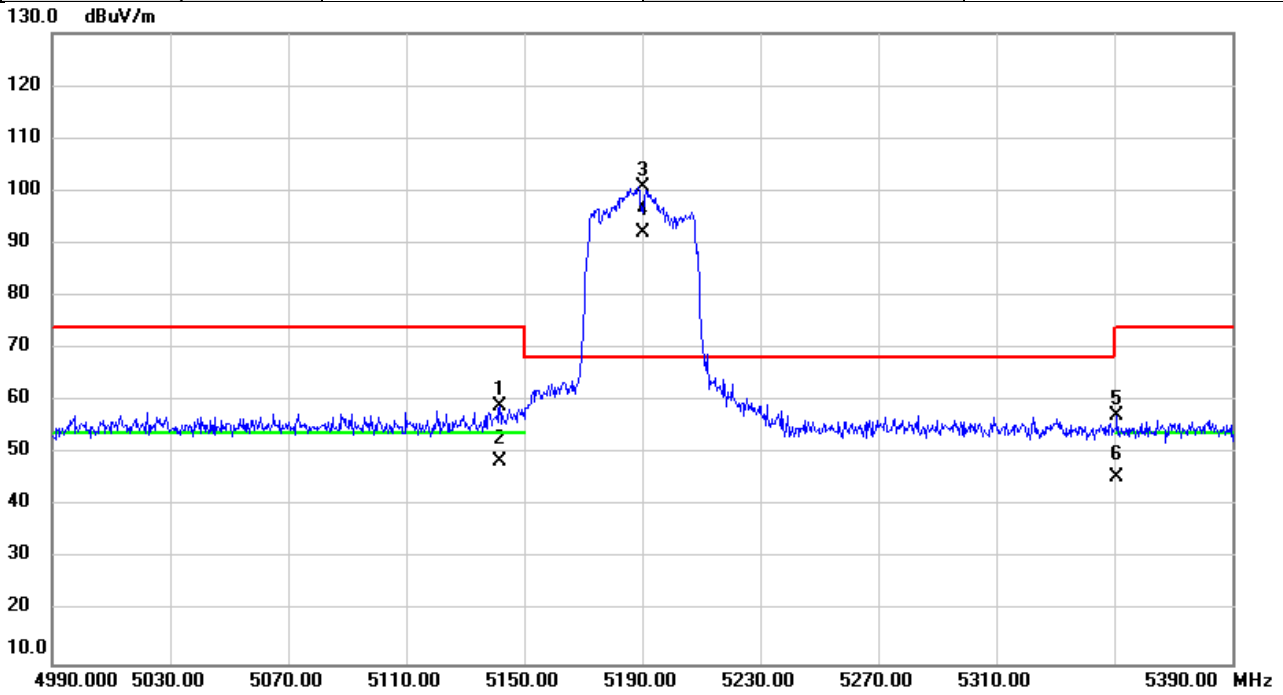

No.	Mk.	Freq.	Reading Level	Correct Factor	Measurement	Limit	Over	Detector	Comment
		MHz	dBuV	dB	dBuV/m	dBuV/m	dB		
1		5141.693	57.49	1.47	58.96	74.00	-15.04	peak	
2		5141.693	47.00	1.47	48.47	54.00	-5.53	AVG	
3	*	5190.000	99.25	1.50	100.75	68.20	32.55	peak	NoLimit
4	X	5190.000	90.70	1.50	92.20	68.20	24.00	AVG	NoLimit
5		5350.947	55.54	1.60	57.14	74.00	-16.86	peak	
6		5350.947	44.00	1.60	45.60	54.00	-8.40	AVG	

REMARKS:

- (1) Measurement Value = Reading Level + Correct Factor.
- (2) Margin Level = Measurement Value - Limit Value.

Test Mode	IEEE 802.11n (HT40)	Test Date	2024/3/26
Test Frequency	5230MHz	Polarization	Horizontal
Temp	24°C	Hum.	64%

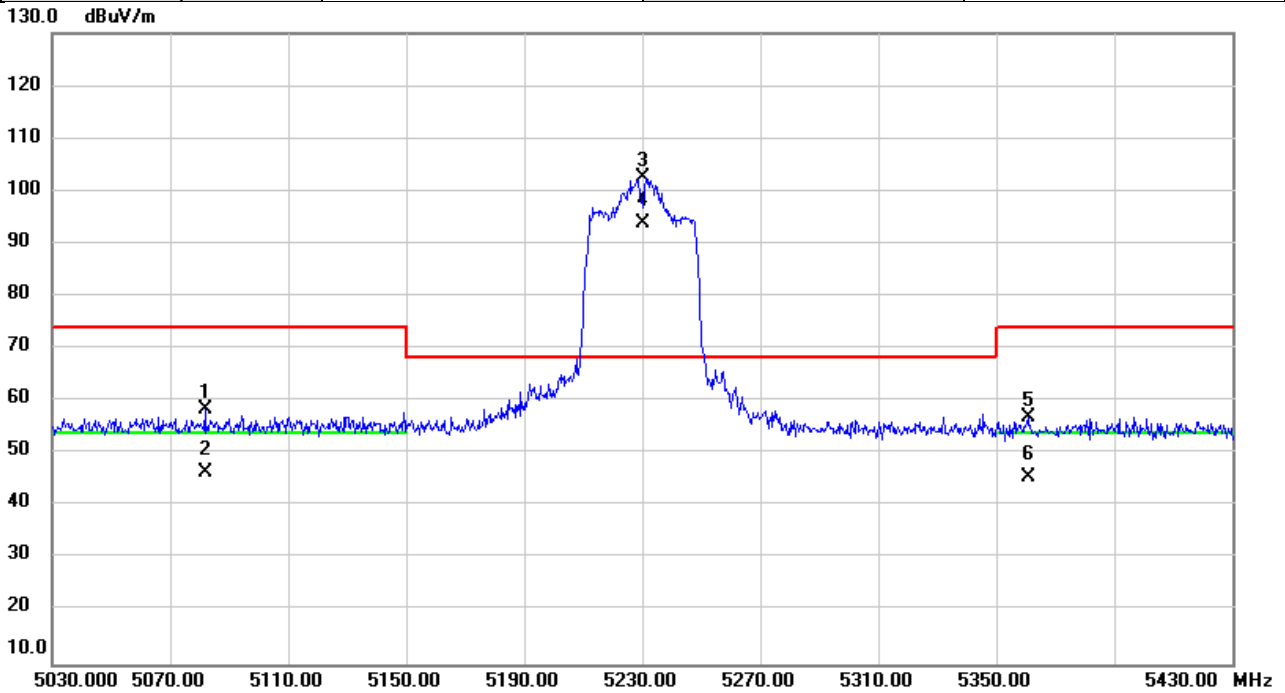

No.	Mk.	Freq.	Reading Level	Correct Factor	Measurement	Limit	Over	Detector	Comment
		MHz	dBuV	dB	dBuV/m	dBuV/m	dB		
1		5081.787	57.02	1.44	58.46	74.00	-15.54	peak	
2		5081.787	44.97	1.44	46.41	54.00	-7.59	AVG	
3	*	5230.000	100.95	1.52	102.47	68.20	34.27	peak	NoLimit
4	X	5230.000	92.24	1.52	93.76	68.20	25.56	AVG	NoLimit
5		5360.680	55.36	1.60	56.96	74.00	-17.04	peak	
6		5360.680	44.09	1.60	45.69	54.00	-8.31	AVG	

REMARKS:

- (1) Measurement Value = Reading Level + Correct Factor.
- (2) Margin Level = Measurement Value - Limit Value.

Test Mode	IEEE 802.11n (HT40)	Test Date	2024/3/26
Test Frequency	5270MHz	Polarization	Horizontal
Temp	24°C	Hum.	64%

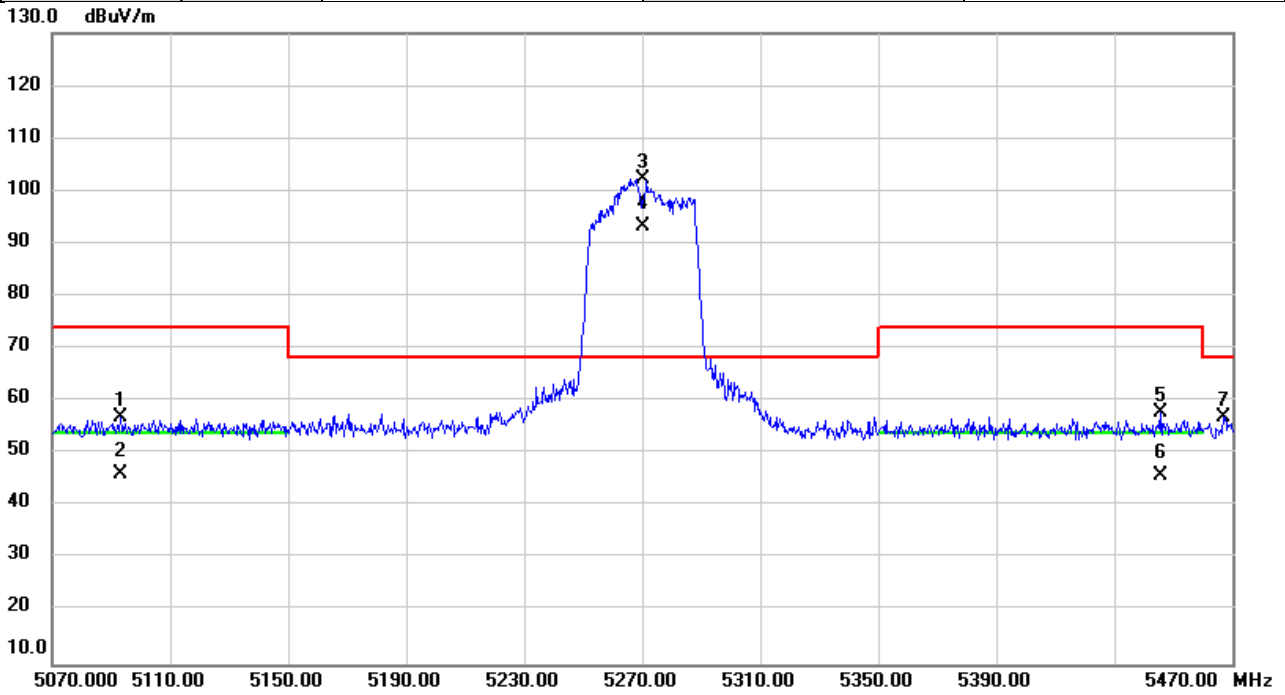

No.	Mk.	Freq.	Reading Level	Correct Factor	Measurement	Limit	Over	Detector	Comment
		MHz	dBuV	dB	dBuV/m	dBuV/m	dB		
1		5092.947	55.56	1.45	57.01	74.00	-16.99	peak	
2		5092.947	44.78	1.45	46.23	54.00	-7.77	AVG	
3	*	5270.000	100.82	1.55	102.37	68.20	34.17	peak	NoLimit
4	X	5270.000	91.80	1.55	93.35	68.20	25.15	AVG	NoLimit
5		5445.547	56.07	1.65	57.72	74.00	-16.28	peak	
6		5445.547	44.19	1.65	45.84	54.00	-8.16	AVG	
7		5467.133	55.22	1.66	56.88	68.20	-11.32	peak	

REMARKS:

- (1) Measurement Value = Reading Level + Correct Factor.
- (2) Margin Level = Measurement Value - Limit Value.

Test Mode	IEEE 802.11n (HT40)	Test Date	2024/3/26
Test Frequency	5310MHz	Polarization	Horizontal
Temp	24°C	Hum.	64%

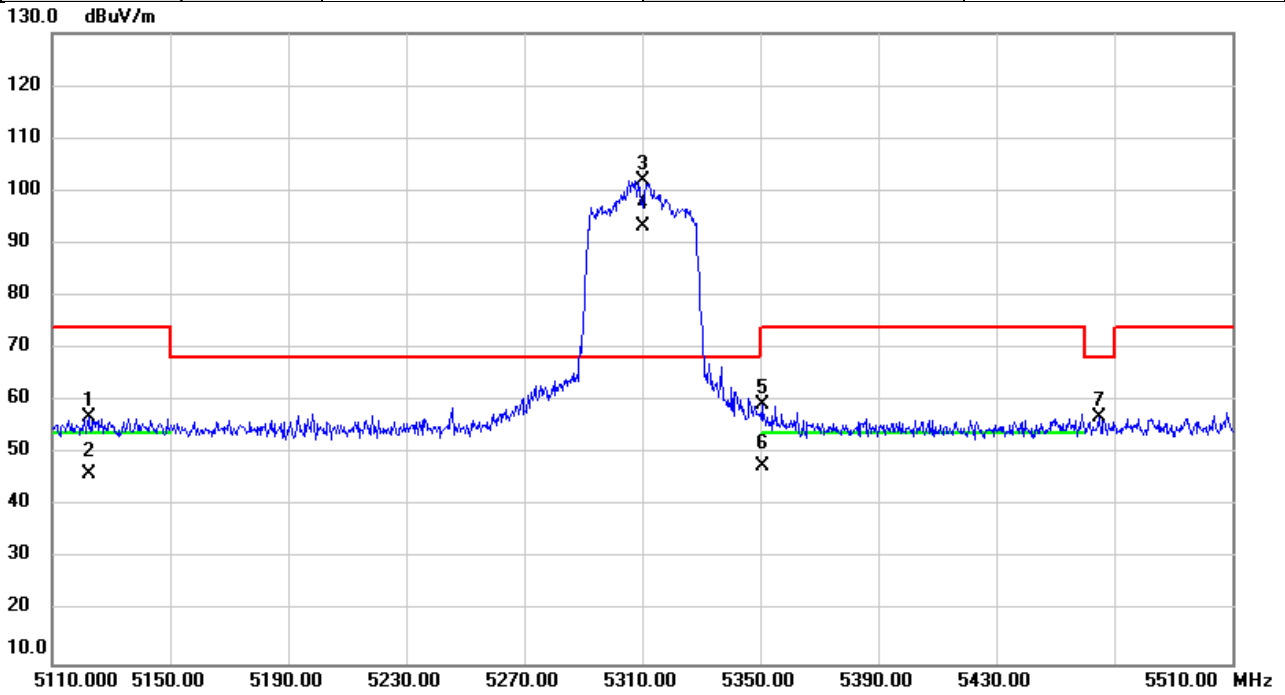

No.	Mk.	Freq.	Reading Level	Correct Factor	Measurement	Limit	Over	Detector	Comment
		MHz	dBuV	dB	dBuV/m	dBuV/m	dB		
1		5122.280	55.55	1.47	57.02	74.00	-16.98	peak	
2		5122.280	44.62	1.47	46.09	54.00	-7.91	AVG	
3	*	5310.000	100.36	1.57	101.93	68.20	33.73	peak	NoLimit
4	X	5310.000	91.71	1.57	93.28	68.20	25.08	AVG	NoLimit
5		5350.733	57.67	1.60	59.27	74.00	-14.73	peak	
6		5350.733	45.93	1.60	47.53	54.00	-6.47	AVG	
7		5464.933	55.43	1.66	57.09	68.20	-11.11	peak	

REMARKS:

- (1) Measurement Value = Reading Level + Correct Factor.
- (2) Margin Level = Measurement Value - Limit Value.

Test Mode	IEEE 802.11n (HT40)	Test Date	2024/3/26
Test Frequency	5510MHz	Polarization	Horizontal
Temp	24°C	Hum.	64%

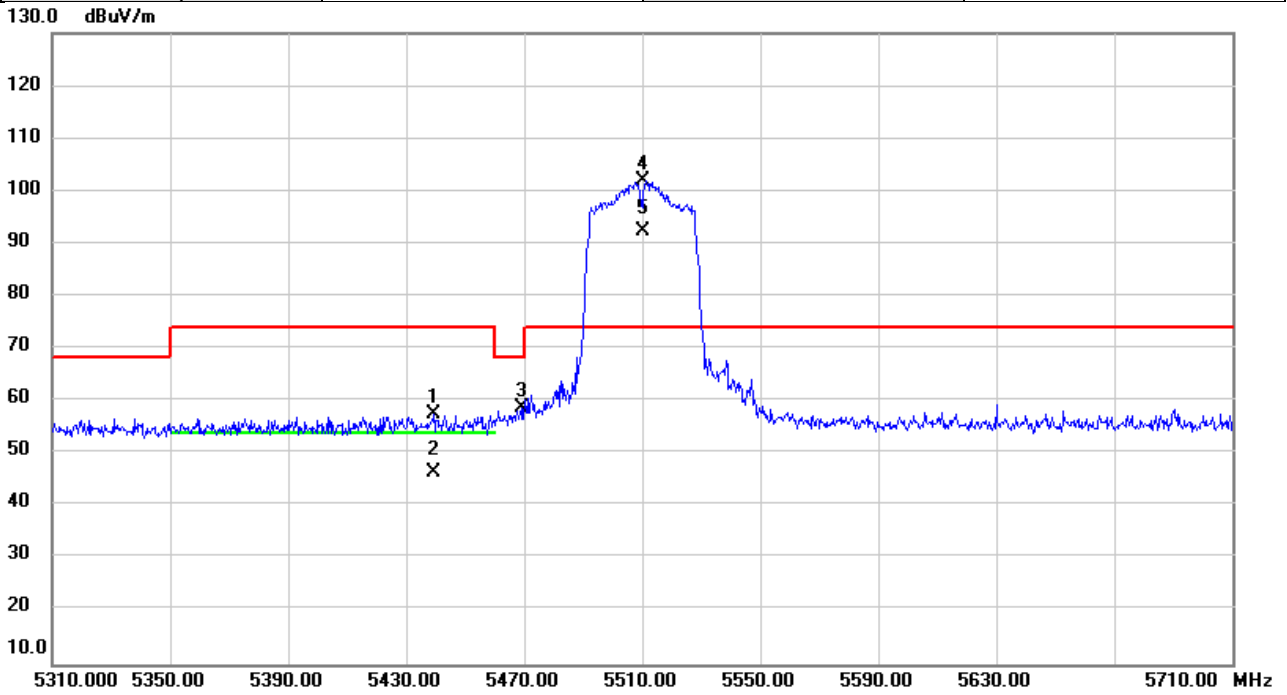

No.	Mk.	Freq.	Reading Level	Correct Factor	Measurement	Limit	Over	Detector	Comment
		MHz	dBuV	dB	dBuV/m	dBuV/m	dB		
1		5439.213	56.01	1.64	57.65	74.00	-16.35	peak	
2		5439.213	44.94	1.64	46.58	54.00	-7.42	AVG	
3		5468.960	57.23	1.66	58.89	68.20	-9.31	peak	
4	*	5510.000	100.12	1.71	101.83	74.00	27.83	peak	NoLimit
5	X	5510.000	90.72	1.71	92.43	74.00	18.43	AVG	NoLimit

REMARKS:

- (1) Measurement Value = Reading Level + Correct Factor.
- (2) Margin Level = Measurement Value - Limit Value.

Test Mode	IEEE 802.11n (HT40)	Test Date	2024/3/26
Test Frequency	5670MHz	Polarization	Horizontal
Temp	24°C	Hum.	64%

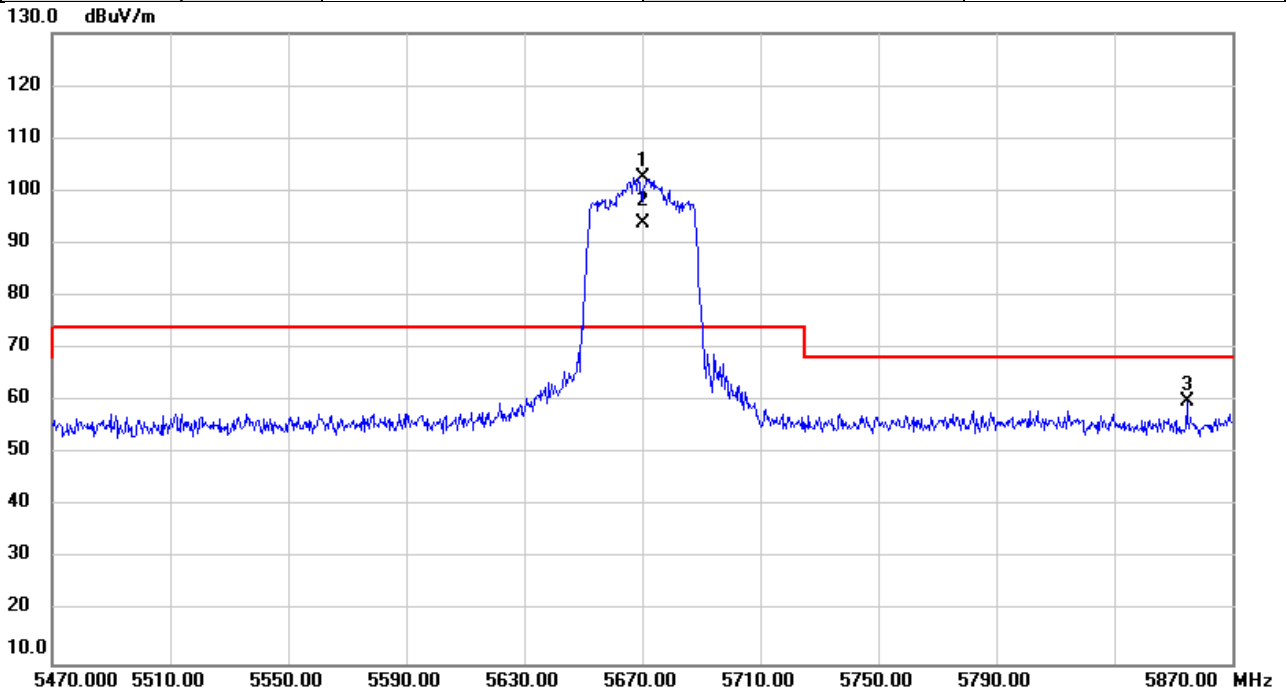

No.	Mk.	Freq.	Reading Level	Correct Factor	Measurement	Limit	Over	Detector	Comment
		MHz	dBuV	dB	dBuV/m	dBuV/m	dB		
1	*	5670.000	100.29	2.18	102.47	74.00	28.47	peak	NoLimit
2	X	5670.000	91.76	2.18	93.94	74.00	19.94	AVG	NoLimit
3		5854.733	57.14	2.70	59.84	68.20	-8.36	peak	

REMARKS:

- (1) Measurement Value = Reading Level + Correct Factor.
- (2) Margin Level = Measurement Value - Limit Value.

Test Mode	IEEE 802.11n (HT40)	Test Date	2024/3/26
Test Frequency	5755MHz	Polarization	Horizontal
Temp	24°C	Hum.	64%

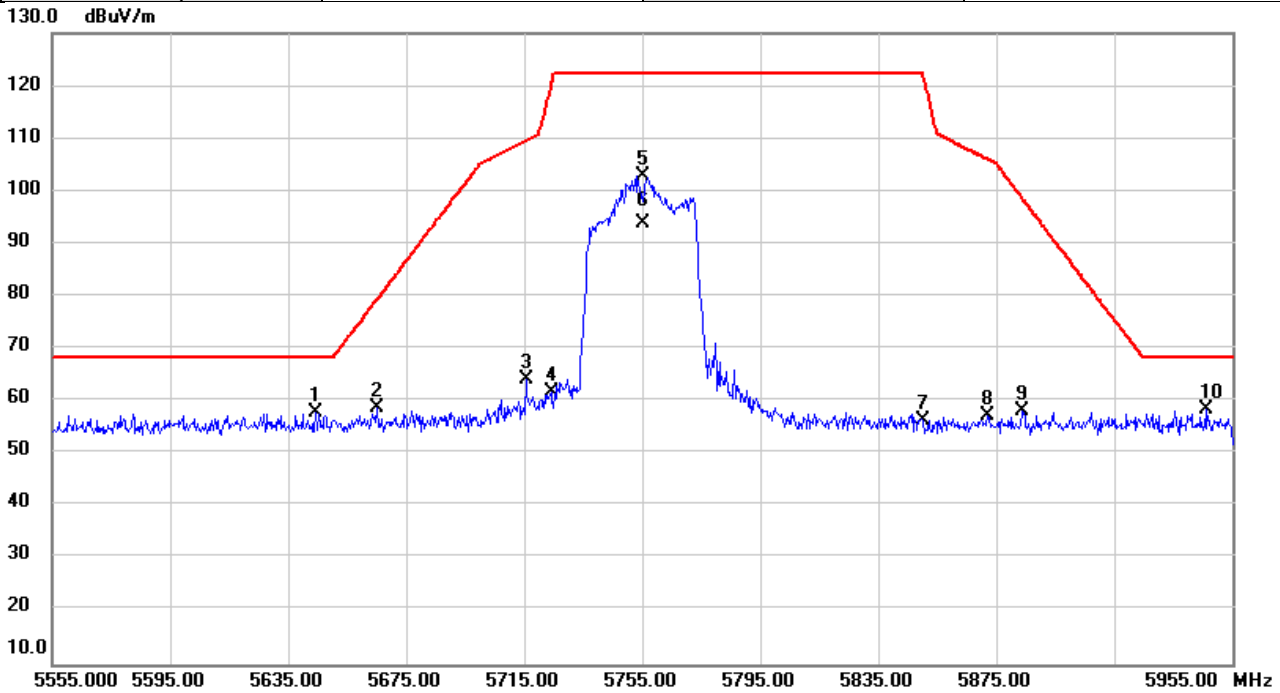

No.	Mk.	Freq.	Reading Level	Correct Factor	Measurement	Limit	Over	Detector	Comment
		MHz	dBuV	dB	dBuV/m	dBuV/m	dB		
1		5644.480	55.70	2.10	57.80	68.20	-10.40	peak	
2		5665.293	56.61	2.16	58.77	79.55	-20.78	peak	
3		5715.627	61.92	2.30	64.22	109.58	-45.36	peak	
4		5724.147	59.34	2.32	61.66	120.26	-58.60	peak	
5		5755.000	100.47	2.42	102.89	122.20	-19.31	peak	NoLimit
6		5755.000	91.35	2.42	93.77	122.20	-28.43	AVG	NoLimit
7		5850.200	53.78	2.68	56.46	121.74	-65.28	peak	
8		5872.027	54.52	2.75	57.27	106.03	-48.76	peak	
9		5883.733	55.42	2.79	58.21	98.71	-40.50	peak	
10	*	5945.987	55.52	2.96	58.48	68.20	-9.72	peak	

REMARKS:

- (1) Measurement Value = Reading Level + Correct Factor.
- (2) Margin Level = Measurement Value - Limit Value.

Test Mode	IEEE 802.11n (HT40)	Test Date	2024/3/26
Test Frequency	5795MHz	Polarization	Horizontal
Temp	24°C	Hum.	64%

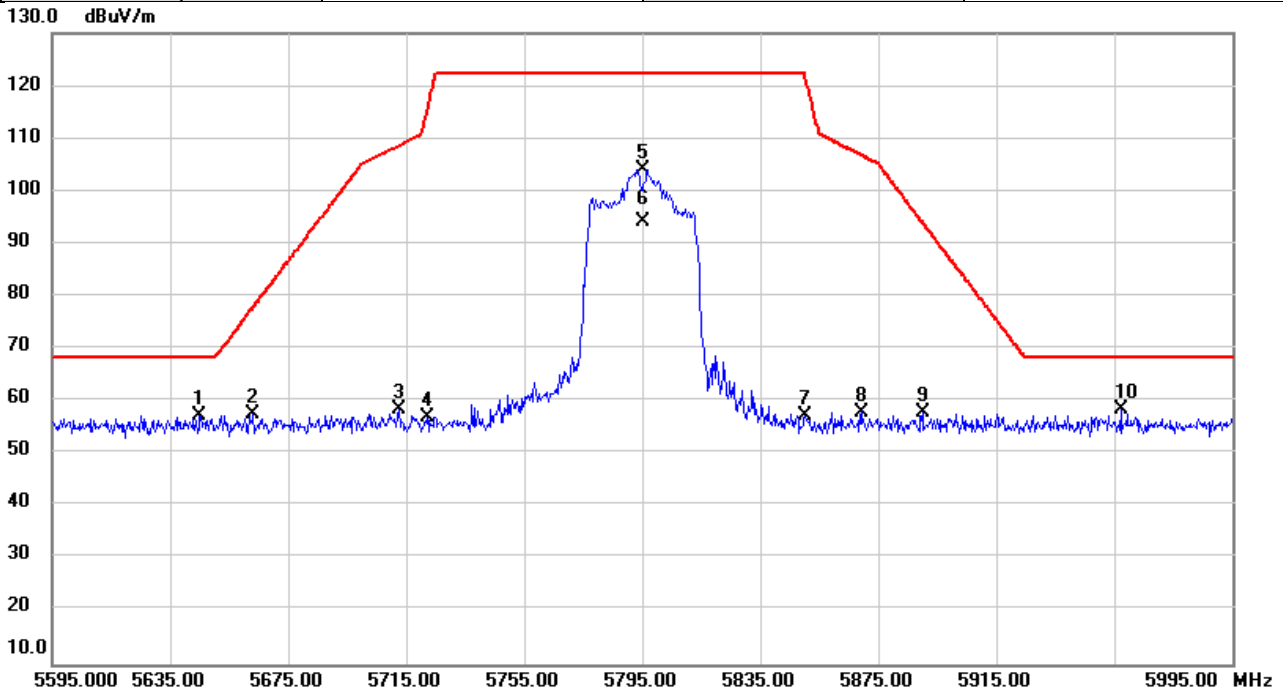

No.	Mk.	Freq.	Reading Level	Correct Factor	Measurement	Limit	Over	Detector	Comment
		MHz	dBuV	dB	dBuV/m	dBuV/m	dB		
1		5645.067	55.17	2.10	57.27	68.20	-10.93	peak	
2		5663.093	55.47	2.15	57.62	77.92	-20.30	peak	
3		5712.440	56.08	2.29	58.37	108.69	-50.32	peak	
4		5722.000	54.70	2.32	57.02	115.36	-58.34	peak	
5		5795.000	101.57	2.53	104.10	122.20	-18.10	peak	NoLimit
6		5795.000	91.76	2.53	94.29	122.20	-27.91	AVG	NoLimit
7		5850.307	54.63	2.68	57.31	121.50	-64.19	peak	
8		5869.307	55.27	2.73	58.00	106.79	-48.79	peak	
9		5890.067	55.05	2.81	57.86	94.02	-36.16	peak	
10	*	5957.160	55.44	3.00	58.44	68.20	-9.76	peak	

REMARKS:

- (1) Measurement Value = Reading Level + Correct Factor.
- (2) Margin Level = Measurement Value - Limit Value.

Test Mode	IEEE 802.11ac (VHT80)	Test Date	2024/3/26
Test Frequency	5210MHz	Polarization	Horizontal
Temp	24°C	Hum.	64%

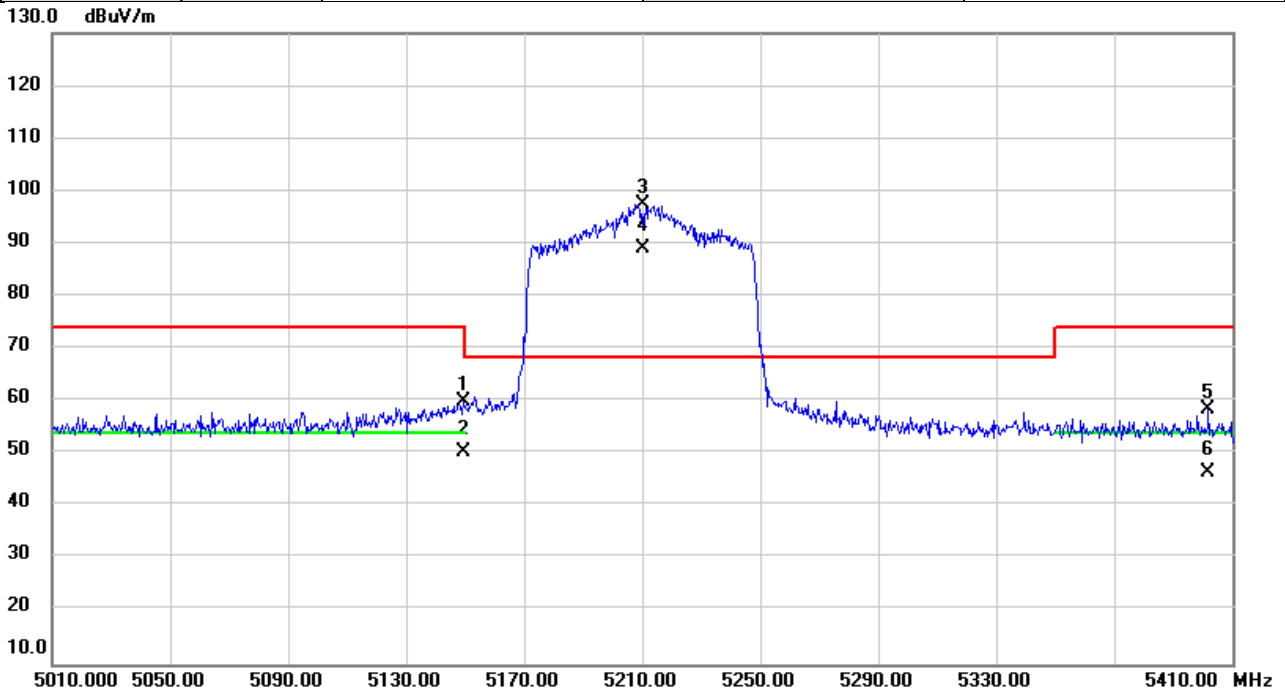

No.	Mk.	Freq.	Reading Level	Correct Factor	Measurement	Limit	Over	Detector	Comment
		MHz	dBuV	dB	dBuV/m	dBuV/m	dB		
1		5149.467	58.53	1.47	60.00	74.00	-14.00	peak	
2		5149.467	48.75	1.47	50.22	54.00	-3.78	AVG	
3	*	5210.000	95.83	1.51	97.34	68.20	29.14	peak	NoLimit
4	X	5210.000	87.39	1.51	88.90	68.20	20.70	AVG	NoLimit
5		5401.707	56.89	1.62	58.51	74.00	-15.49	peak	
6		5401.707	44.81	1.62	46.43	54.00	-7.57	AVG	

REMARKS:

- (1) Measurement Value = Reading Level + Correct Factor.
- (2) Margin Level = Measurement Value - Limit Value.

Test Mode	IEEE 802.11ac (VHT80)	Test Date	2024/3/26
Test Frequency	5290MHz	Polarization	Horizontal
Temp	24°C	Hum.	64%

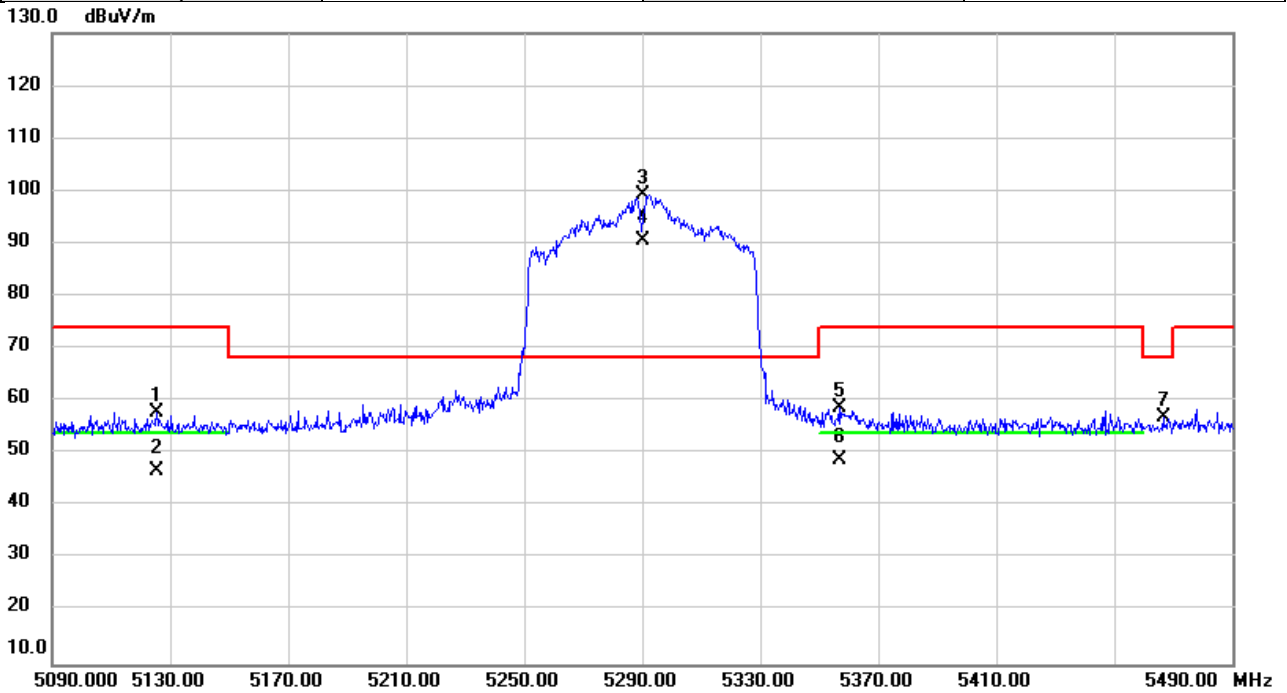

No.	Mk.	Freq.	Reading Level	Correct Factor	Measurement	Limit	Over	Detector	Comment
		MHz	dBuV	dB	dBuV/m	dBuV/m	dB		
1		5125.453	56.36	1.46	57.82	74.00	-16.18	peak	
2		5125.453	45.29	1.46	46.75	54.00	-7.25	AVG	
3	*	5290.000	97.65	1.56	99.21	68.20	31.01	peak	NoLimit
4	X	5290.000	88.94	1.56	90.50	68.20	22.30	AVG	NoLimit
5		5356.733	57.16	1.60	58.76	74.00	-15.24	peak	
6		5356.733	47.22	1.60	48.82	54.00	-5.18	AVG	
7		5466.573	55.19	1.66	56.85	68.20	-11.35	peak	

REMARKS:

- (1) Measurement Value = Reading Level + Correct Factor.
- (2) Margin Level = Measurement Value - Limit Value.

Test Mode	IEEE 802.11ac (VHT80)	Test Date	2024/3/26
Test Frequency	5530MHz	Polarization	Horizontal
Temp	24°C	Hum.	64%

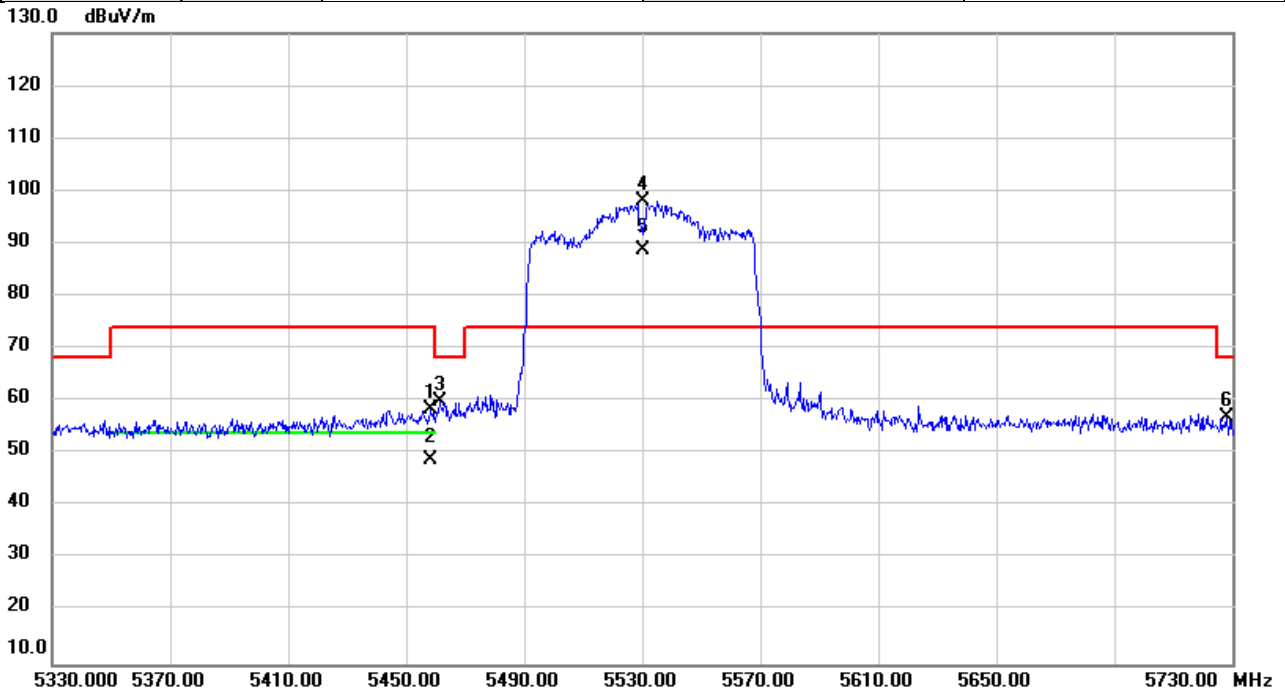

No.	Mk.	Freq.	Reading Level	Correct Factor	Measurement	Limit	Over	Detector	Comment
		MHz	dBuV	dB	dBuV/m	dBuV/m	dB		
1		5458.307	56.80	1.65	58.45	74.00	-15.55	peak	
2		5458.307	47.06	1.65	48.71	54.00	-5.29	AVG	
3		5461.573	58.37	1.66	60.03	68.20	-8.17	peak	
4	*	5530.000	96.33	1.76	98.09	74.00	24.09	peak	NoLimit
5	X	5530.000	87.05	1.76	88.81	74.00	14.81	AVG	NoLimit
6		5728.240	54.60	2.34	56.94	68.20	-11.26	peak	

REMARKS:

- (1) Measurement Value = Reading Level + Correct Factor.
- (2) Margin Level = Measurement Value - Limit Value.

Test Mode	IEEE 802.11ac (VHT80)	Test Date	2024/3/26
Test Frequency	5610MHz	Polarization	Horizontal
Temp	24°C	Hum.	64%

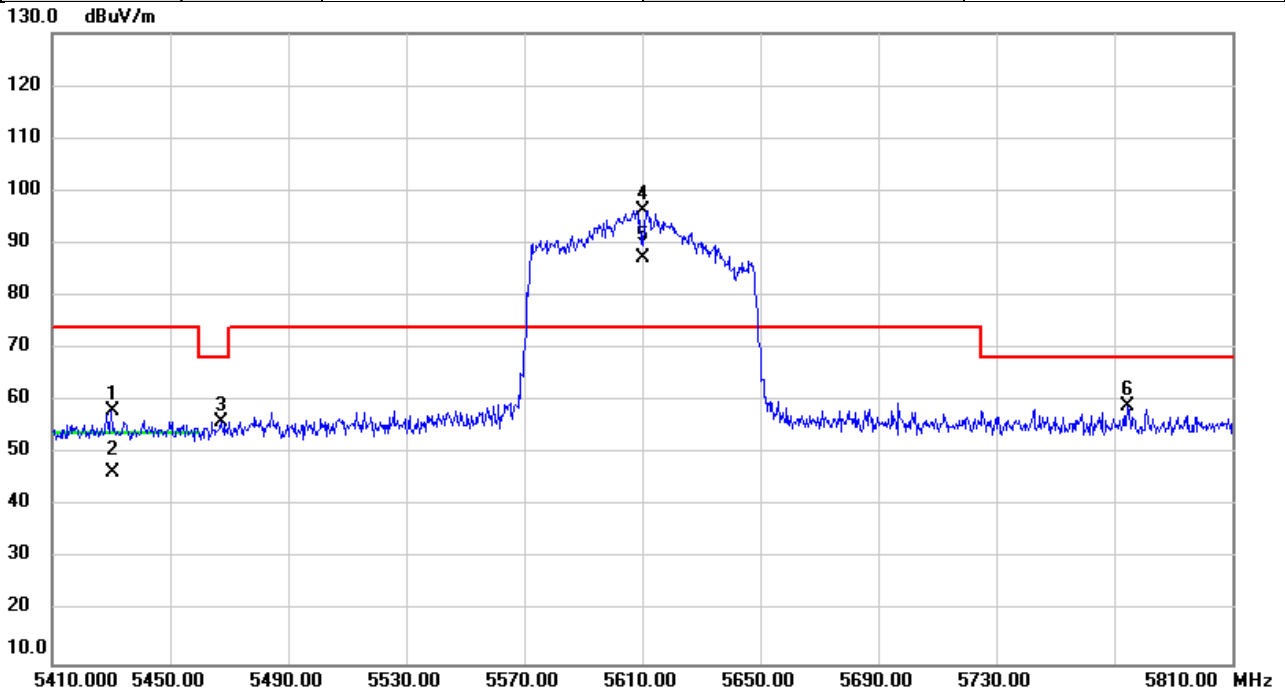

No.	Mk.	Freq.	Reading Level	Correct Factor	Measurement	Limit	Over	Detector	Comment
		MHz	dBuV	dB	dBuV/m	dBuV/m	dB		
1		5430.267	56.43	1.64	58.07	74.00	-15.93	peak	
2		5430.267	44.69	1.64	46.33	54.00	-7.67	AVG	
3		5467.293	54.39	1.66	56.05	68.20	-12.15	peak	
4	*	5610.000	94.34	1.99	96.33	74.00	22.33	peak	NoLimit
5	X	5610.000	85.30	1.99	87.29	74.00	13.29	AVG	NoLimit
6		5774.707	56.55	2.47	59.02	68.20	-9.18	peak	

REMARKS:

- (1) Measurement Value = Reading Level + Correct Factor.
- (2) Margin Level = Measurement Value - Limit Value.

Test Mode	IEEE 802.11ac (VHT80)	Test Date	2024/3/26
Test Frequency	5775MHz	Polarization	Horizontal
Temp	24°C	Hum.	64%

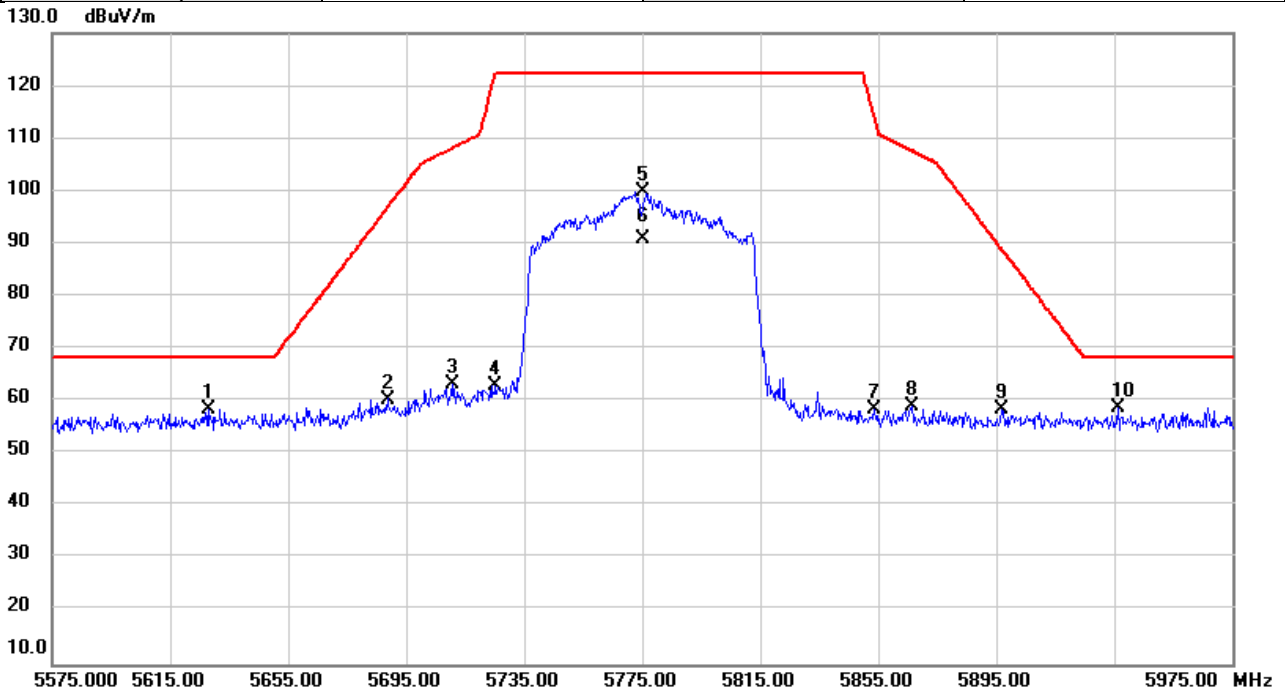

No.	Mk.	Freq.	Reading Level	Correct Factor	Measurement	Limit	Over	Detector	Comment
		MHz	dBuV	dB	dBuV/m	dBuV/m	dB		
1		5627.867	56.30	2.05	58.35	68.20	-9.85	peak	
2		5688.947	58.17	2.23	60.40	97.05	-36.65	peak	
3		5710.493	61.01	2.29	63.30	108.14	-44.84	peak	
4		5725.133	60.71	2.33	63.04	122.20	-59.16	peak	
5		5775.000	97.38	2.47	99.85	122.20	-22.35	peak	NoLimit
6		5775.000	88.33	2.47	90.80	122.20	-31.40	AVG	NoLimit
7		5853.547	55.65	2.70	58.35	114.11	-55.76	peak	
8		5866.213	56.34	2.73	59.07	107.66	-48.59	peak	
9		5896.947	55.75	2.82	58.57	88.92	-30.35	peak	
10	*	5936.453	55.85	2.94	58.79	68.20	-9.41	peak	

REMARKS:

- (1) Measurement Value = Reading Level + Correct Factor.
- (2) Margin Level = Measurement Value - Limit Value.

Test Mode	IEEE 802.11a	Test Date	2024/3/26
Test Frequency	5180MHz	Polarization	Vertical
Temp	24°C	Hum.	64%

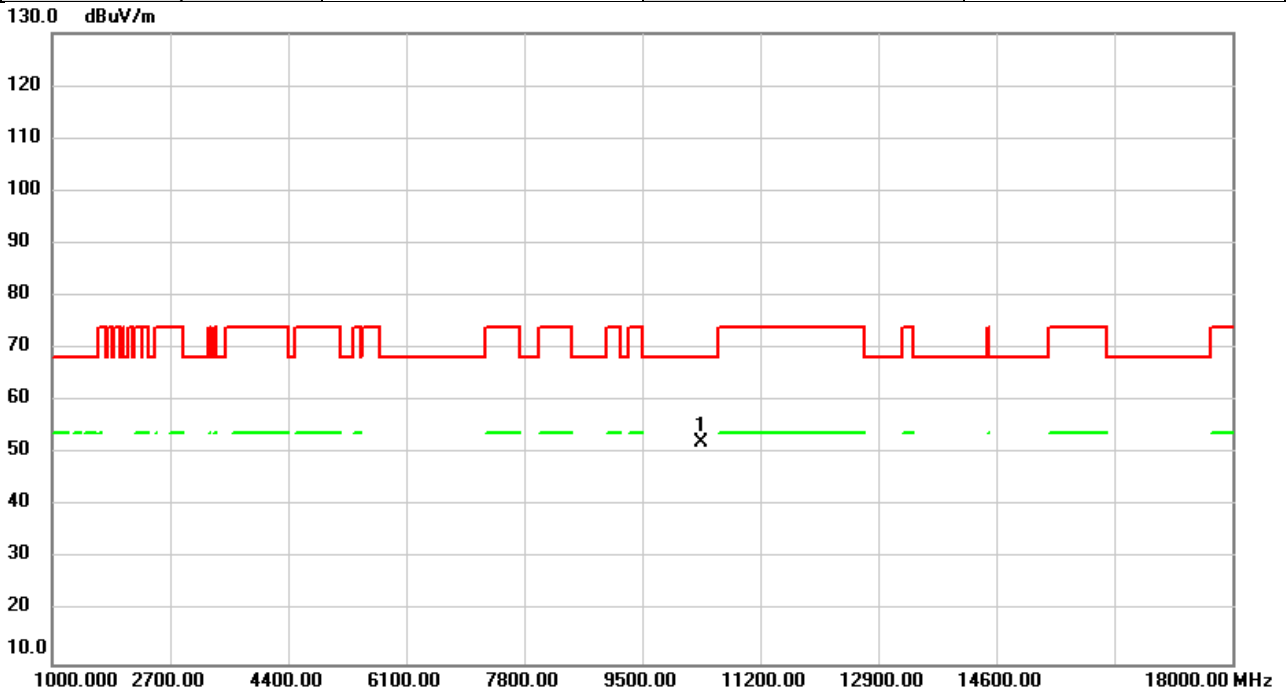

No.	Mk.	Freq.	Reading Level	Correct Factor	Measurement	Limit	Over	Detector	Comment
		MHz	dBuV	dB	dBuV/m	dBuV/m	dB		
1	*	10360.00	45.36	6.66	52.02	68.20	-16.18	peak	

REMARKS:

- (1) Measurement Value = Reading Level + Correct Factor.
- (2) Margin Level = Measurement Value - Limit Value.

Test Mode	IEEE 802.11a	Test Date	2024/3/26
Test Frequency	5180MHz	Polarization	Horizontal
Temp	24°C	Hum.	64%

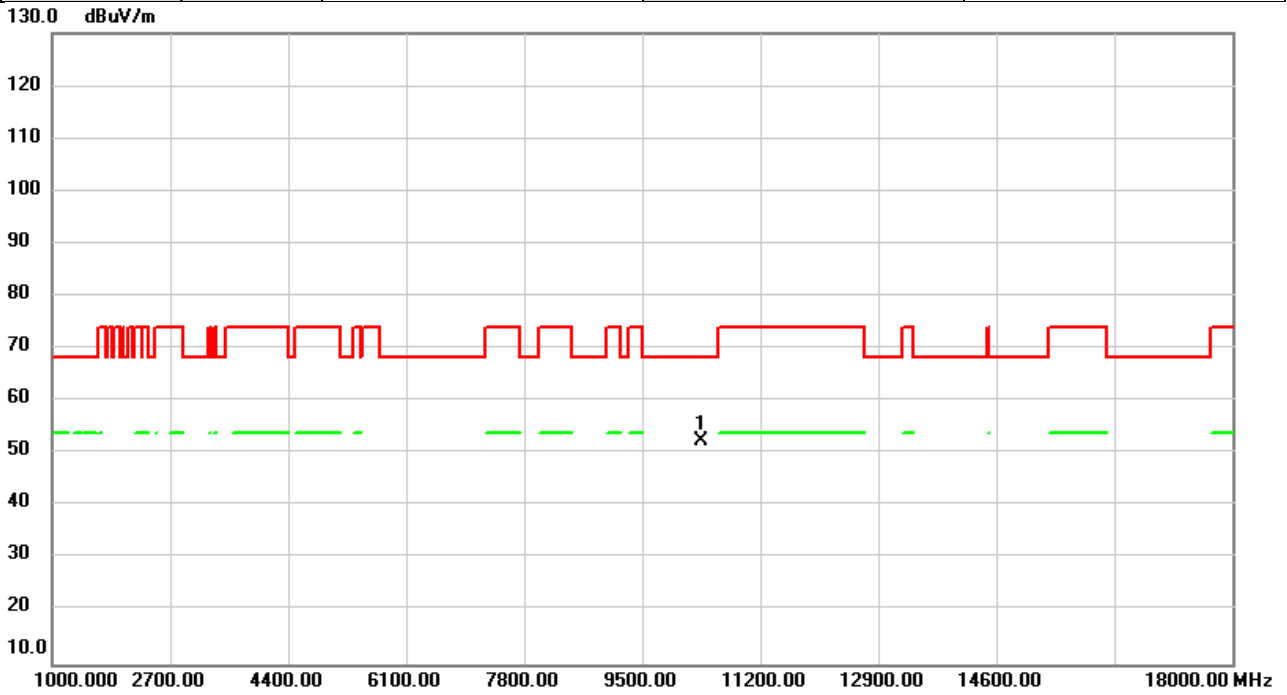

No.	Mk.	Freq.	Reading Level	Correct Factor	Measurement	Limit	Over	Detector	Comment
		MHz	dBuV	dB	dBuV/m	dBuV/m	dB		
1	*	10360.00	45.73	6.66	52.39	68.20	-15.81	peak	

REMARKS:

- (1) Measurement Value = Reading Level + Correct Factor.
- (2) Margin Level = Measurement Value - Limit Value.

Test Mode	IEEE 802.11a	Test Date	2024/3/26
Test Frequency	5200MHz	Polarization	Vertical
Temp	24°C	Hum.	64%

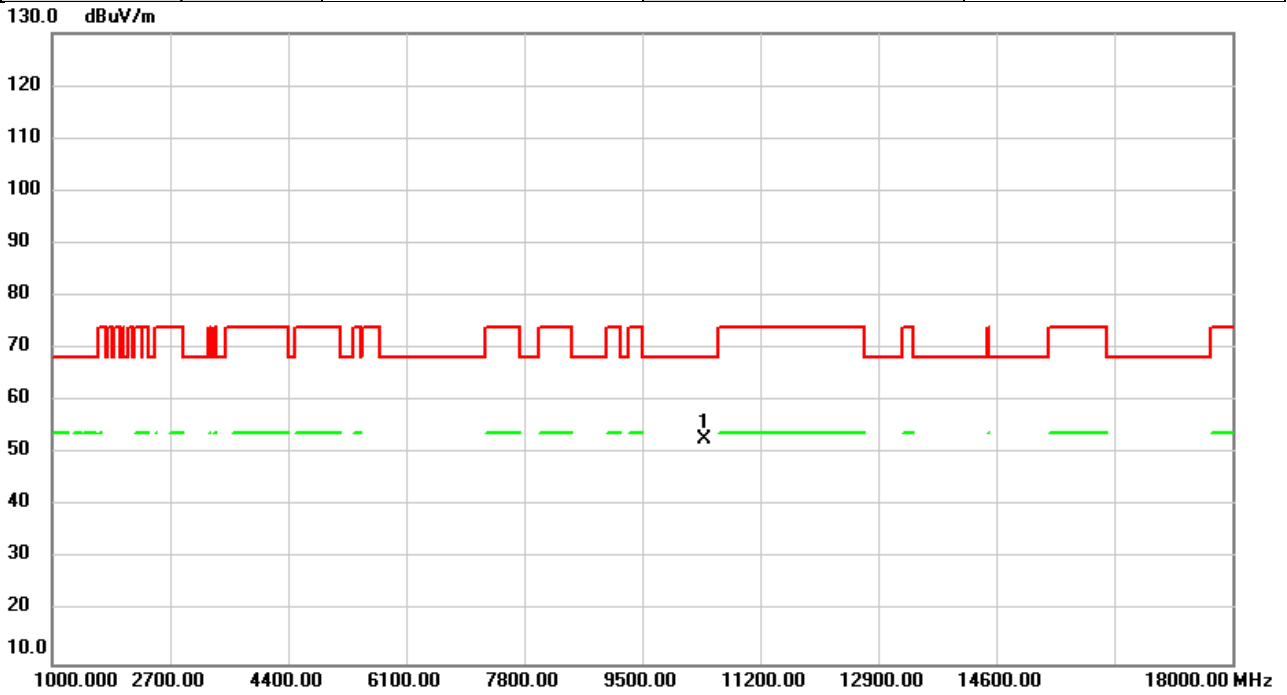

No.	Mk.	Freq.	Reading Level	Correct Factor	Measurement	Limit	Over	Detector	Comment
		MHz	dBuV	dB	dBuV/m	dBuV/m	dB		
1	*	10400.00	46.08	6.68	52.76	68.20	-15.44	peak	

REMARKS:

- (1) Measurement Value = Reading Level + Correct Factor.
- (2) Margin Level = Measurement Value - Limit Value.

Test Mode	IEEE 802.11a	Test Date	2024/3/26
Test Frequency	5200MHz	Polarization	Horizontal
Temp	24°C	Hum.	64%

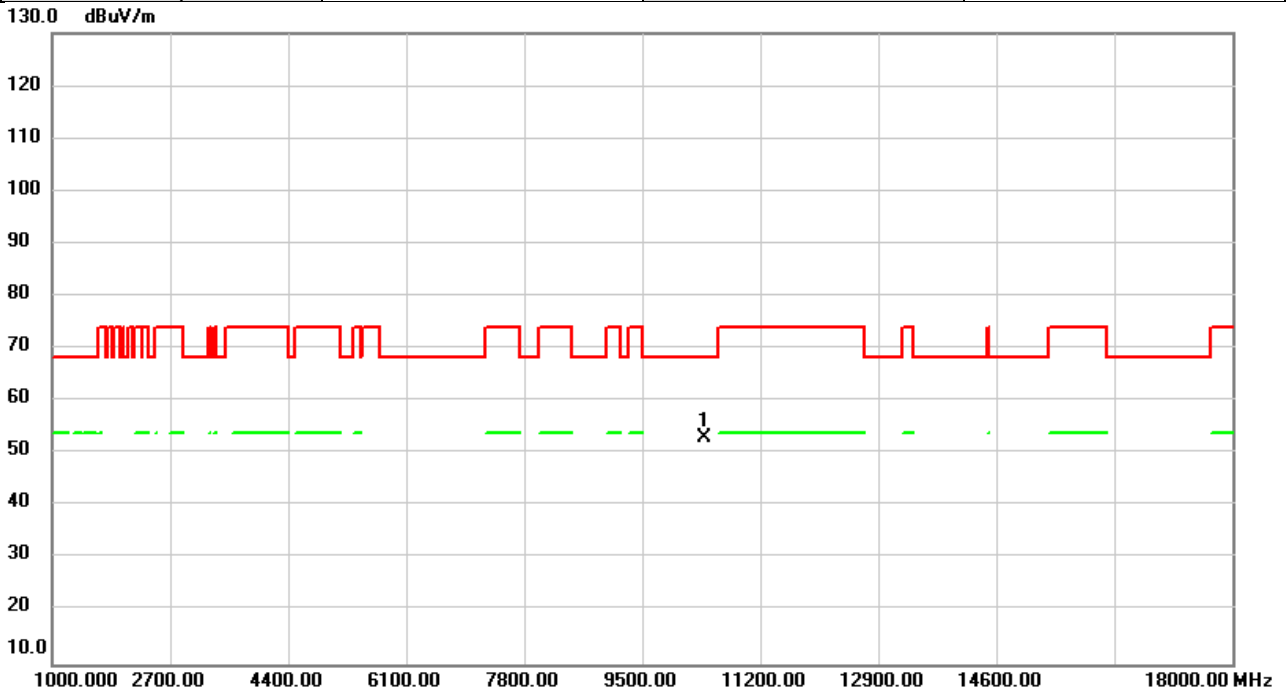

No.	Mk.	Freq.	Reading Level	Correct Factor	Measurement	Limit	Over	Detector	Comment
		MHz	dBuV	dB	dBuV/m	dBuV/m	dB		
1	*	10400.00	46.51	6.68	53.19	68.20	-15.01	peak	

REMARKS:

- (1) Measurement Value = Reading Level + Correct Factor.
- (2) Margin Level = Measurement Value - Limit Value.

Test Mode	IEEE 802.11a	Test Date	2024/3/26
Test Frequency	5240MHz	Polarization	Vertical
Temp	24°C	Hum.	64%

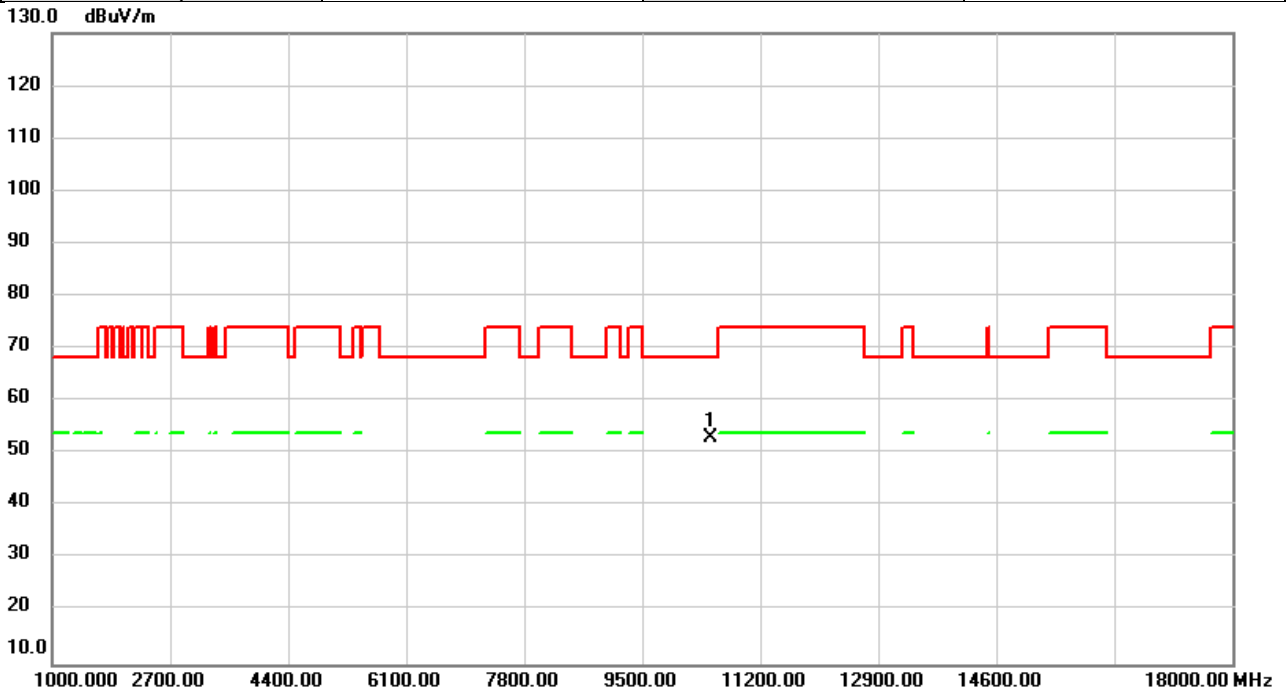

No.	Mk.	Freq.	Reading Level	Correct Factor	Measurement	Limit	Over	Detector	Comment
		MHz	dBuV	dB	dBuV/m	dBuV/m	dB		
1	*	10480.00	46.35	6.71	53.06	68.20	-15.14	peak	

REMARKS:

- (1) Measurement Value = Reading Level + Correct Factor.
- (2) Margin Level = Measurement Value - Limit Value.

Test Mode	IEEE 802.11a	Test Date	2024/3/26
Test Frequency	5240MHz	Polarization	Horizontal
Temp	24°C	Hum.	64%

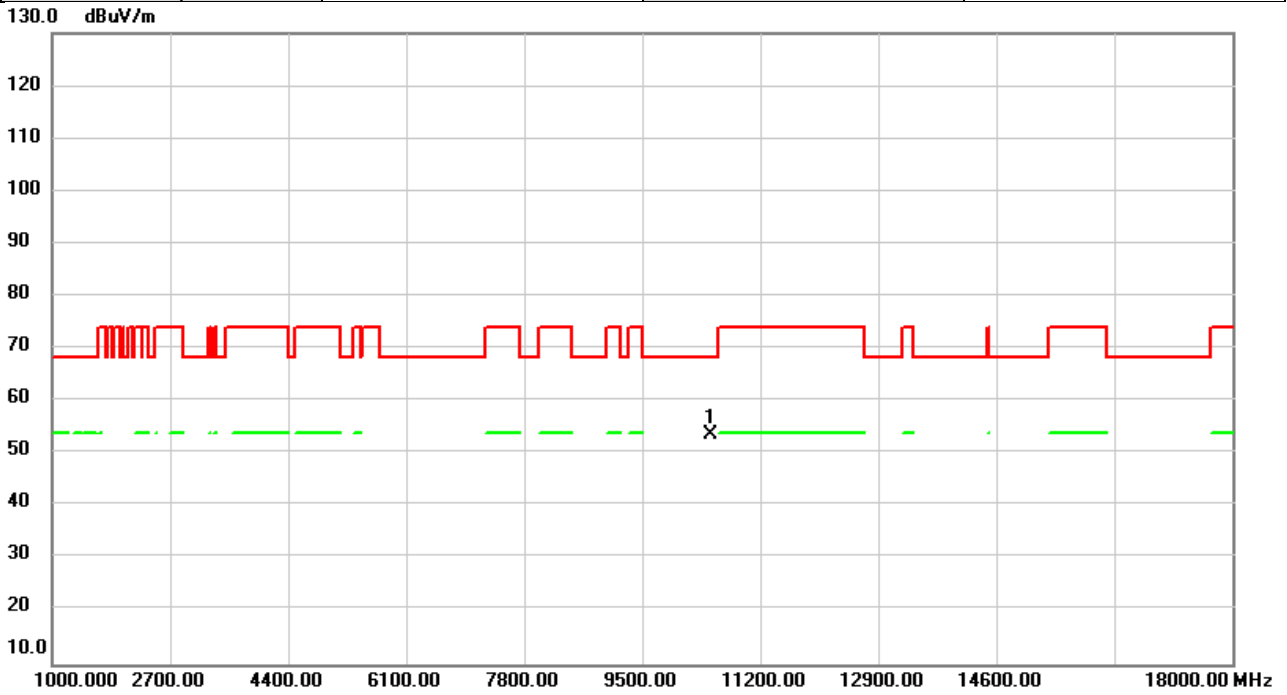

No.	Mk.	Freq.	Reading Level	Correct Factor	Measurement	Limit	Over	Detector	Comment
		MHz	dBuV	dB	dBuV/m	dBuV/m	dB		
1	*	10480.00	47.00	6.71	53.71	68.20	-14.49	peak	

REMARKS:

- (1) Measurement Value = Reading Level + Correct Factor.
- (2) Margin Level = Measurement Value - Limit Value.

Test Mode	IEEE 802.11a	Test Date	2024/3/26
Test Frequency	5260MHz	Polarization	Vertical
Temp	24°C	Hum.	64%

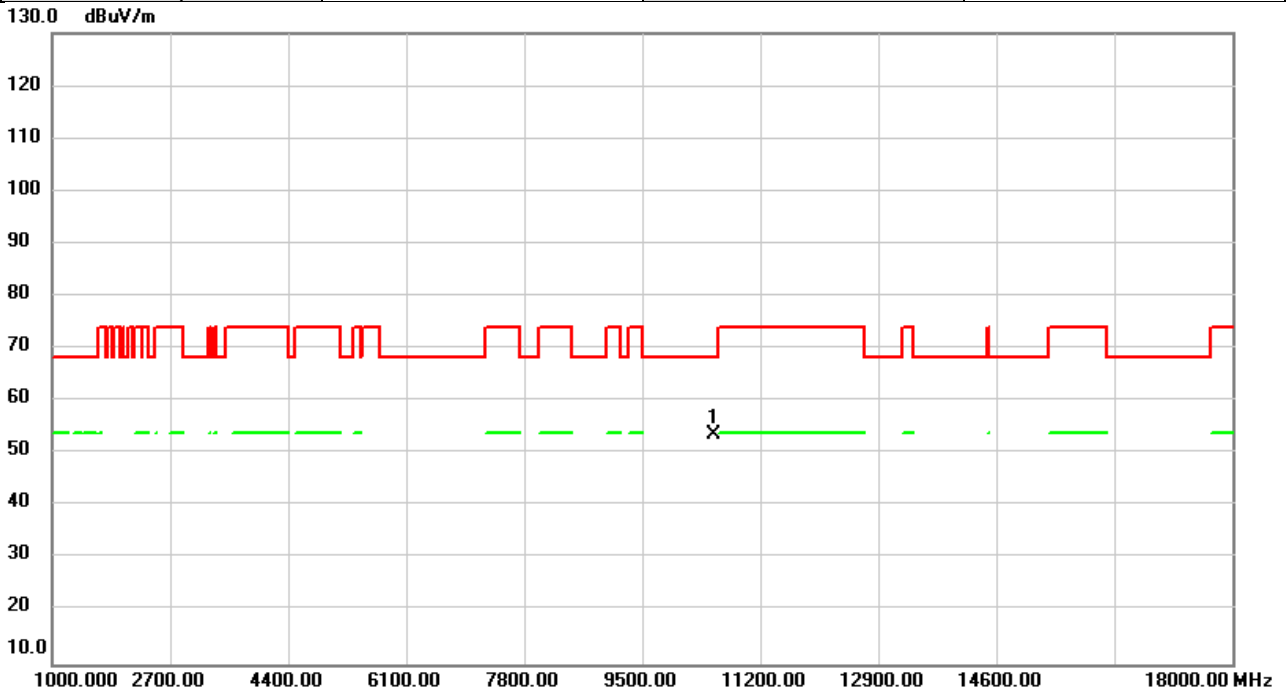

No.	Mk.	Freq.	Reading Level	Correct Factor	Measurement	Limit	Over	Detector	Comment
		MHz	dBuV	dB	dBuV/m	dBuV/m	dB		
1	*	10520.00	47.06	6.73	53.79	68.20	-14.41	peak	

REMARKS:

- (1) Measurement Value = Reading Level + Correct Factor.
- (2) Margin Level = Measurement Value - Limit Value.

Test Mode	IEEE 802.11a	Test Date	2024/3/26
Test Frequency	5260MHz	Polarization	Horizontal
Temp	24°C	Hum.	64%

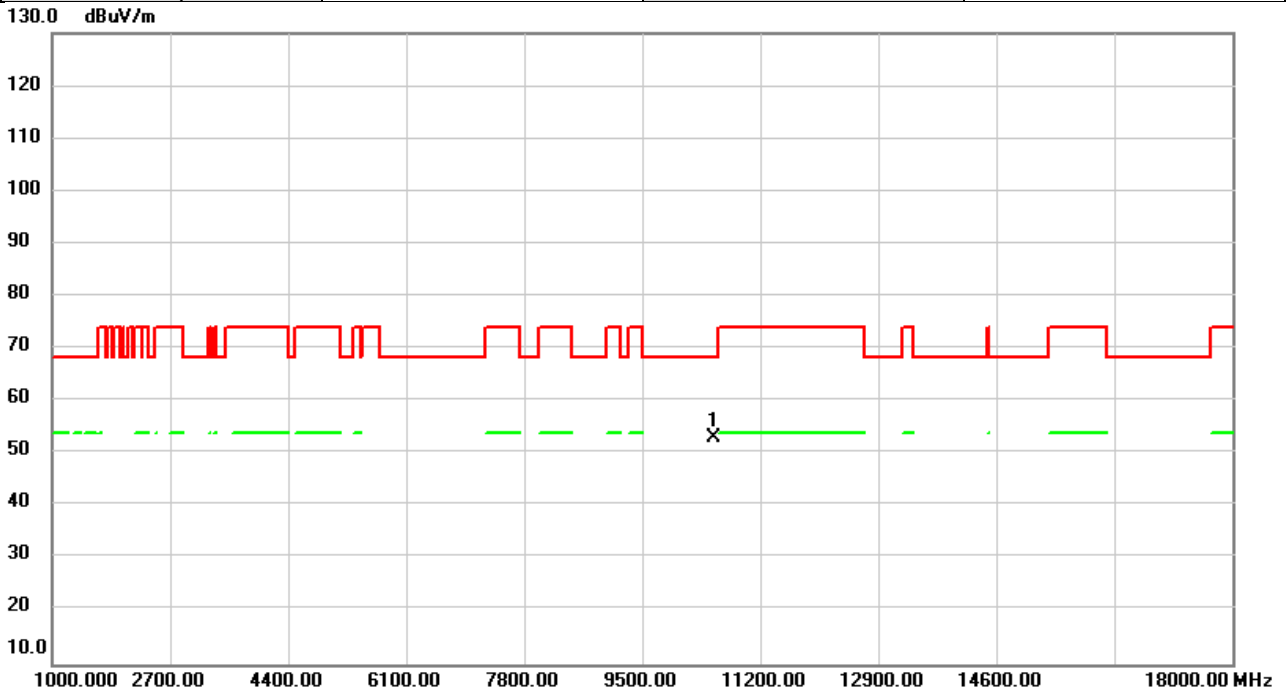

No.	Mk.	Freq.	Reading Level	Correct Factor	Measurement	Limit	Over	Detector	Comment
		MHz	dBuV	dB	dBuV/m	dBuV/m	dB		
1	*	10520.00	46.28	6.73	53.01	68.20	-15.19	peak	

REMARKS:

- (1) Measurement Value = Reading Level + Correct Factor.
- (2) Margin Level = Measurement Value - Limit Value.

Test Mode	IEEE 802.11a	Test Date	2024/3/26
Test Frequency	5300MHz	Polarization	Vertical
Temp	24°C	Hum.	64%

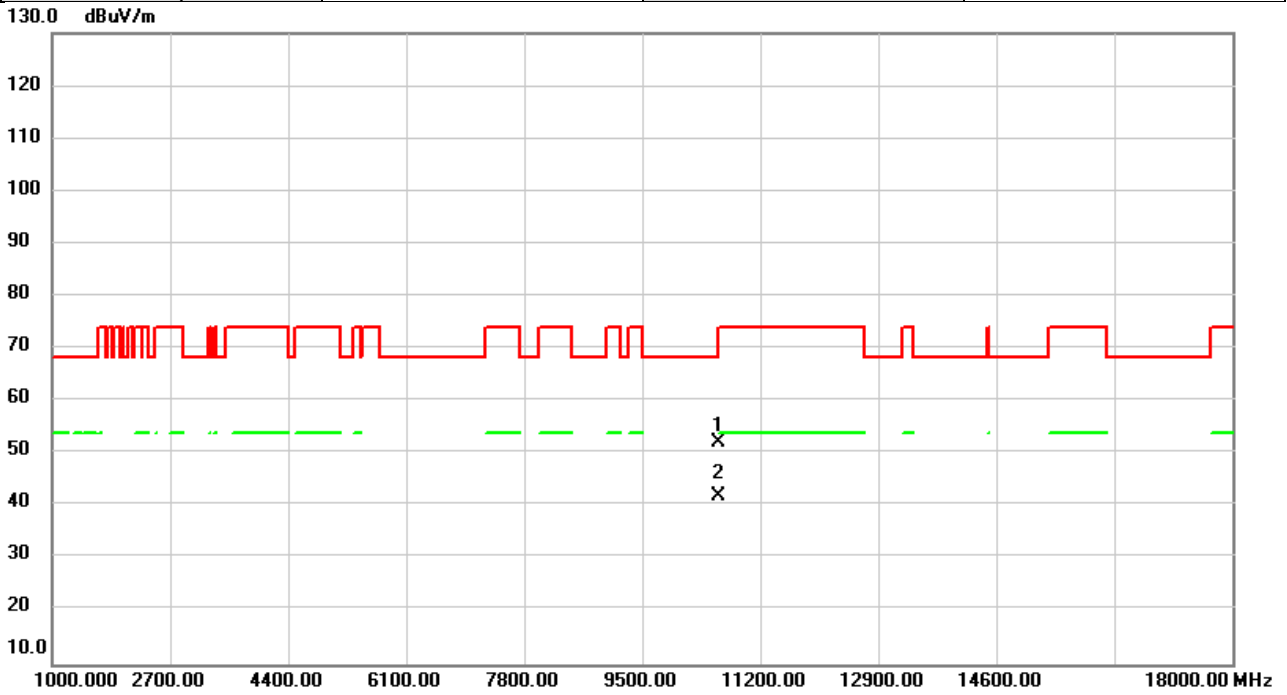

No.	Mk.	Freq. MHz	Reading Level dBuV	Correct Factor dB	Measure- ment dBuV/m	Limit dBuV/m	Over dB	Detector	Comment
1		10600.00	45.46	6.81	52.27	68.20	-15.93	peak	
2	*	10600.00	35.27	6.81	42.08	54.00	-11.92	AVG	

REMARKS:

- (1) Measurement Value = Reading Level + Correct Factor.
- (2) Margin Level = Measurement Value - Limit Value.

Test Mode	IEEE 802.11a	Test Date	2024/3/26
Test Frequency	5300MHz	Polarization	Horizontal
Temp	24°C	Hum.	64%

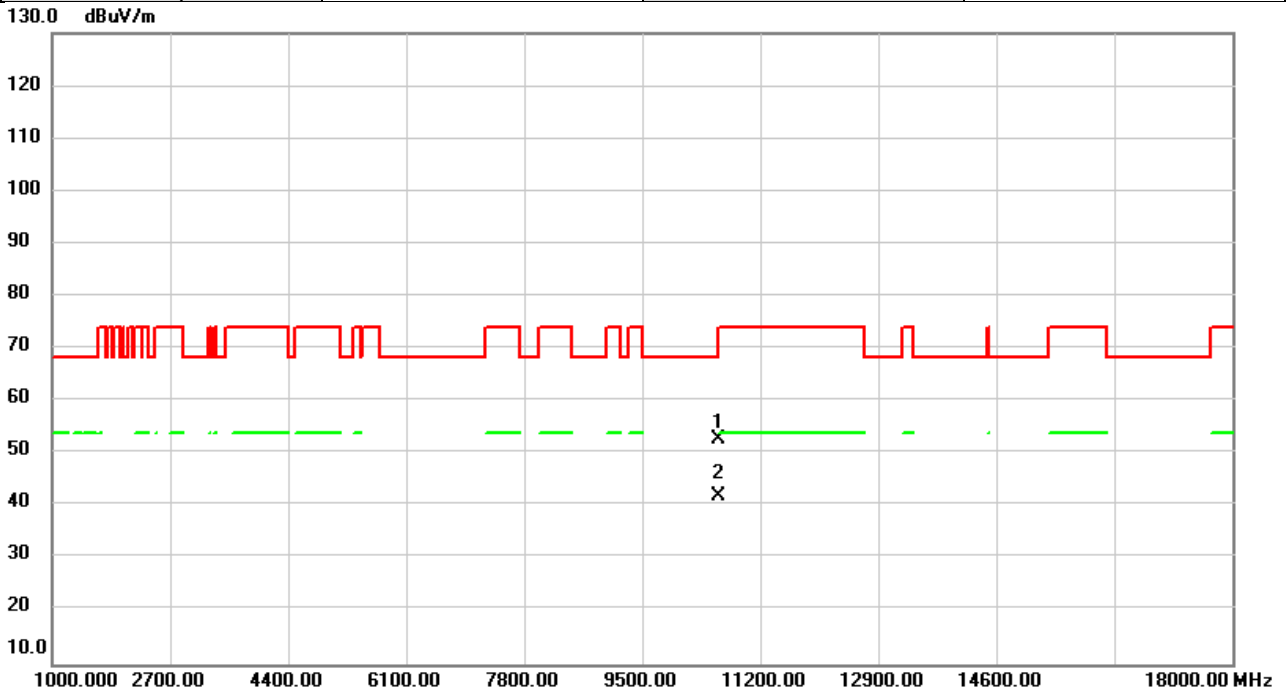

No.	Mk.	Freq.	Reading Level	Correct Factor	Measurement	Limit	Over	Detector	Comment
		MHz	dBuV	dB	dBuV/m	dBuV/m	dB		
1		10600.00	45.82	6.81	52.63	68.20	-15.57	peak	
2	*	10600.00	35.17	6.81	41.98	54.00	-12.02	AVG	

REMARKS:

- (1) Measurement Value = Reading Level + Correct Factor.
- (2) Margin Level = Measurement Value - Limit Value.

Test Mode	IEEE 802.11a	Test Date	2024/3/26
Test Frequency	5320MHz	Polarization	Vertical
Temp	24°C	Hum.	64%

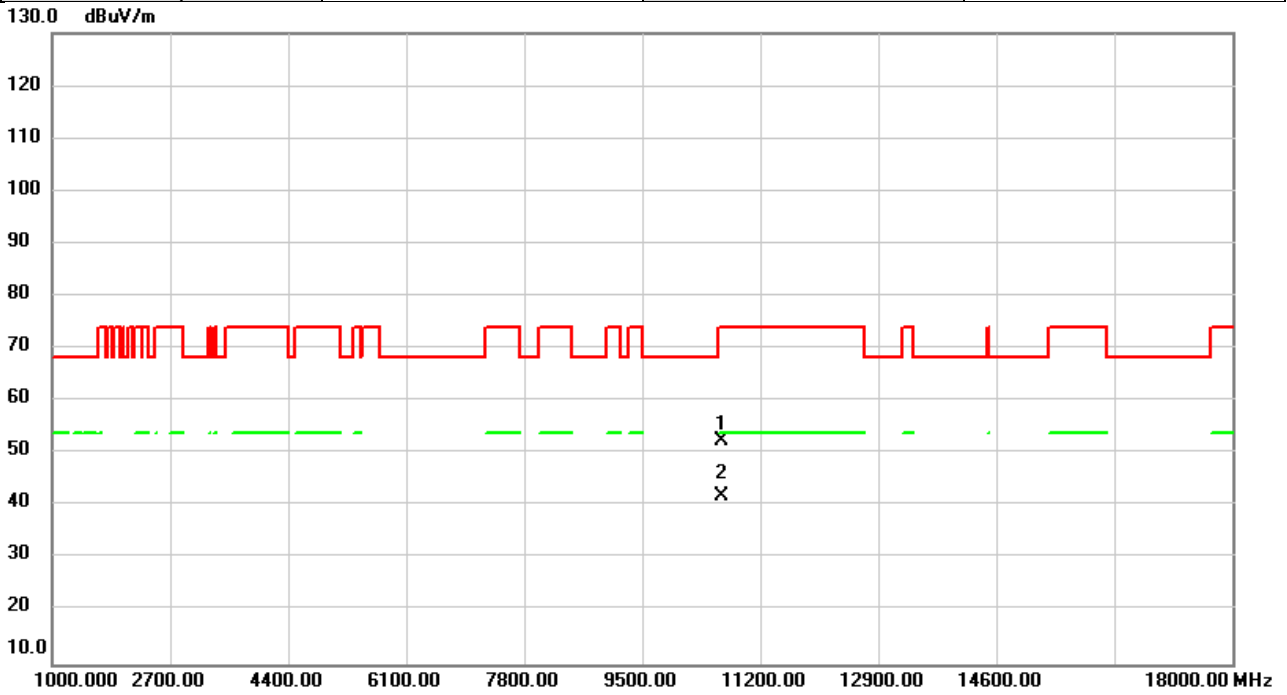

No.	Mk.	Freq. MHz	Reading Level dBuV	Correct Factor dB	Measure- ment dBuV/m	Limit dBuV/m	Over dB	Detector	Comment
1		10640.00	45.71	6.85	52.56	74.00	-21.44	peak	
2	*	10640.00	35.01	6.85	41.86	54.00	-12.14	AVG	

REMARKS:

- (1) Measurement Value = Reading Level + Correct Factor.
- (2) Margin Level = Measurement Value - Limit Value.

Test Mode	IEEE 802.11a	Test Date	2024/3/26
Test Frequency	5320MHz	Polarization	Horizontal
Temp	24°C	Hum.	64%

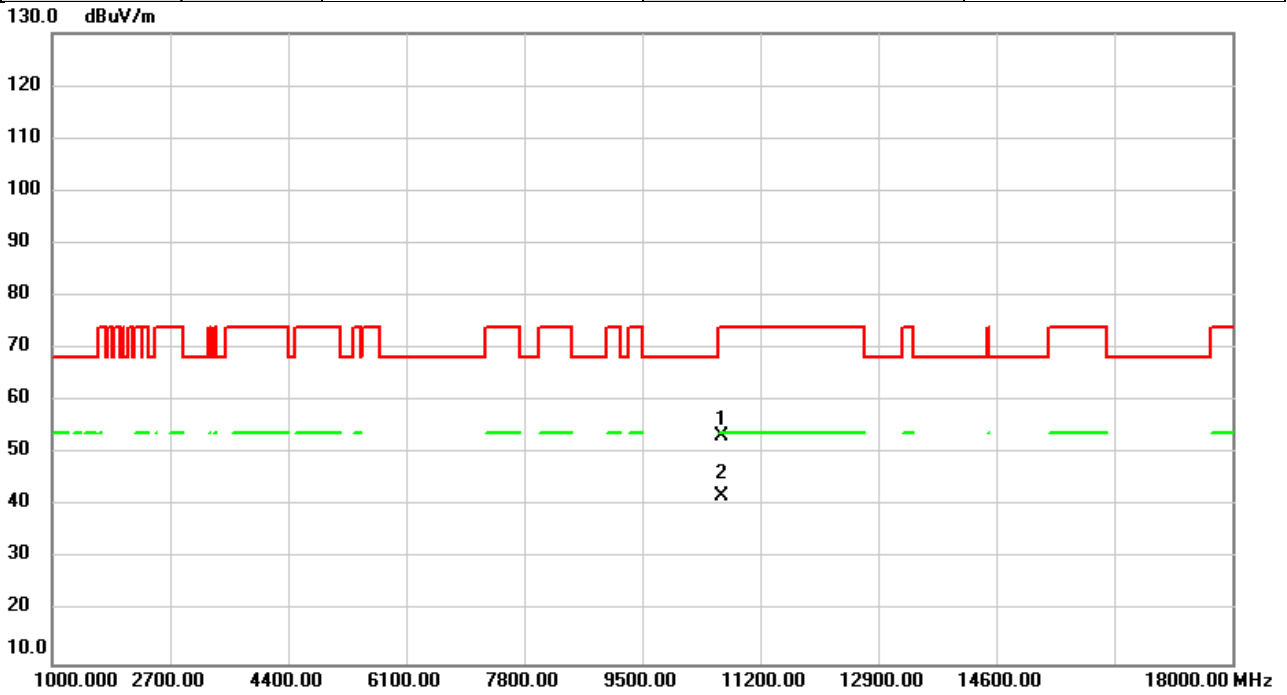

No.	Mk.	Freq.	Reading Level	Correct Factor	Measurement	Limit	Over	Detector	Comment
		MHz	dBuV	dB	dBuV/m	dBuV/m	dB		
1		10640.00	46.44	6.85	53.29	74.00	-20.71	peak	
2	*	10640.00	35.18	6.85	42.03	54.00	-11.97	AVG	

REMARKS:

- (1) Measurement Value = Reading Level + Correct Factor.
- (2) Margin Level = Measurement Value - Limit Value.

Test Mode	IEEE 802.11a	Test Date	2024/3/26
Test Frequency	5500MHz	Polarization	Vertical
Temp	24°C	Hum.	64%

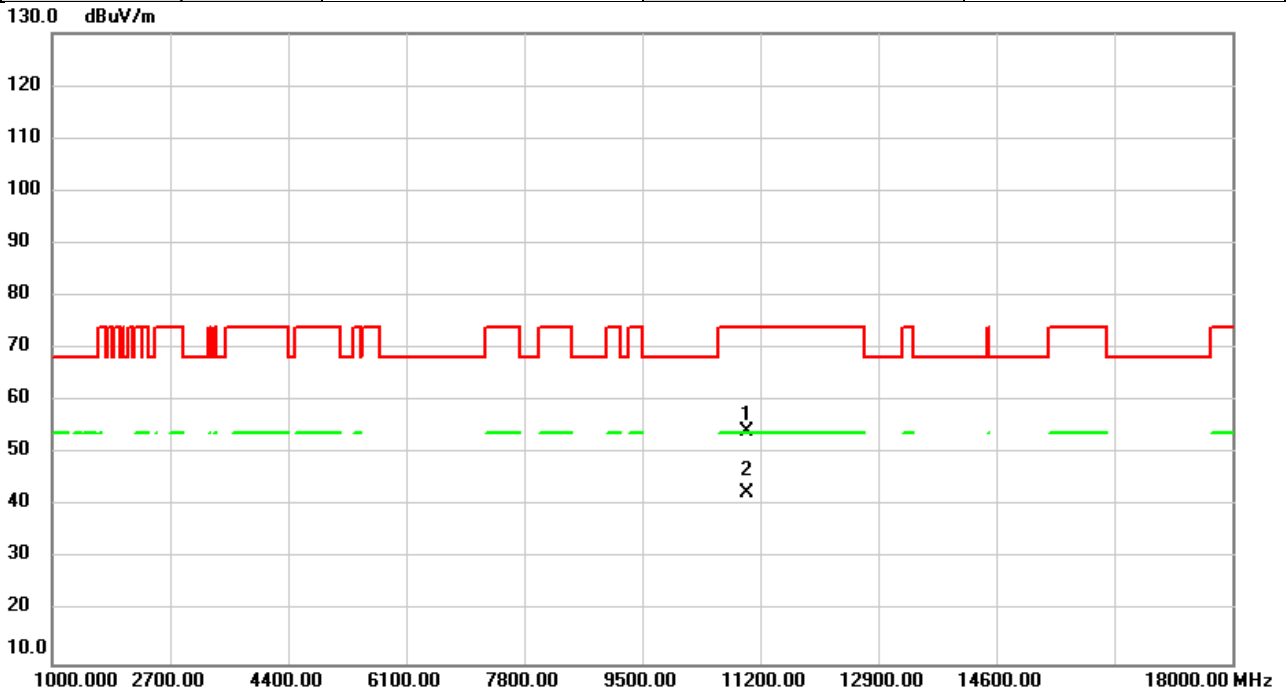

No.	Mk.	Freq.	Reading Level	Correct Factor	Measurement	Limit	Over	Detector	Comment
		MHz	dBuV	dB	dBuV/m	dBuV/m	dB		
1		11000.00	47.20	7.19	54.39	74.00	-19.61	peak	
2	*	11000.00	35.46	7.19	42.65	54.00	-11.35	AVG	

REMARKS:

- (1) Measurement Value = Reading Level + Correct Factor.
- (2) Margin Level = Measurement Value - Limit Value.

Test Mode	IEEE 802.11a	Test Date	2024/3/26
Test Frequency	5500MHz	Polarization	Horizontal
Temp	24°C	Hum.	64%

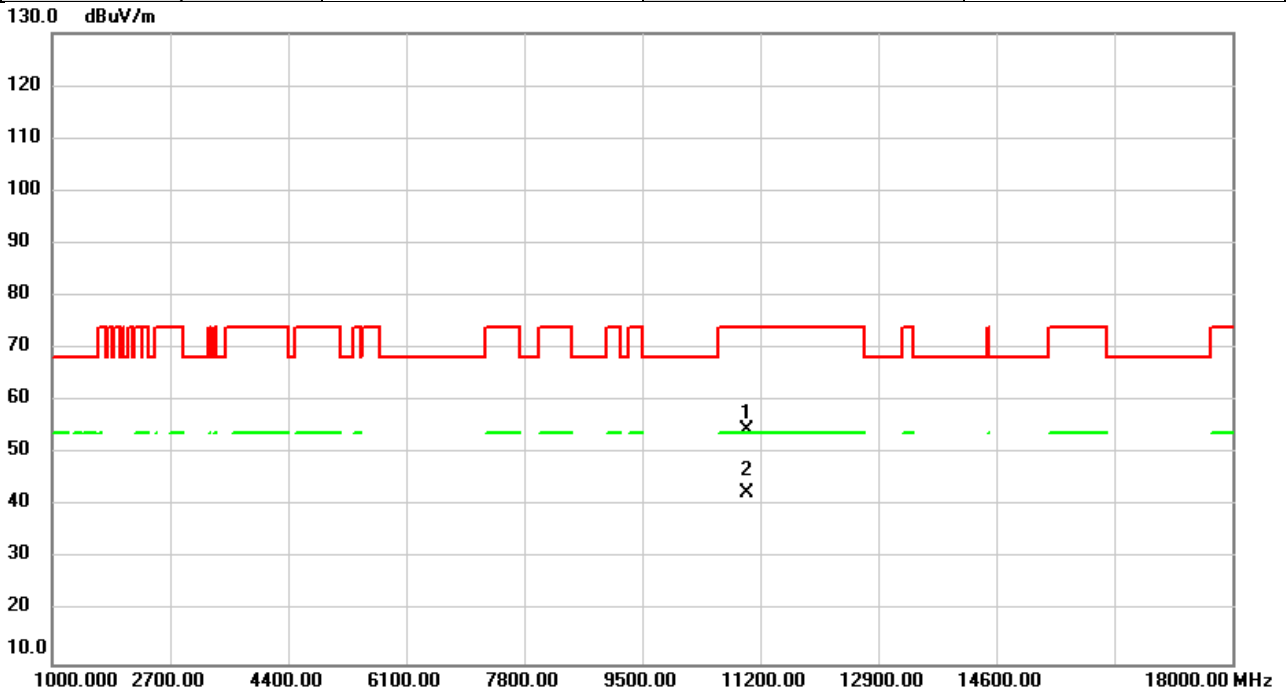

No.	Mk.	Freq.	Reading Level	Correct Factor	Measurement	Limit	Over	Detector	Comment
		MHz	dBuV	dB	dBuV/m	dBuV/m	dB		
1		11000.00	47.25	7.19	54.44	74.00	-19.56	peak	
2	*	11000.00	35.37	7.19	42.56	54.00	-11.44	AVG	

REMARKS:

- (1) Measurement Value = Reading Level + Correct Factor.
- (2) Margin Level = Measurement Value - Limit Value.

Test Mode	IEEE 802.11a	Test Date	2024/3/26
Test Frequency	5580MHz	Polarization	Vertical
Temp	24°C	Hum.	64%

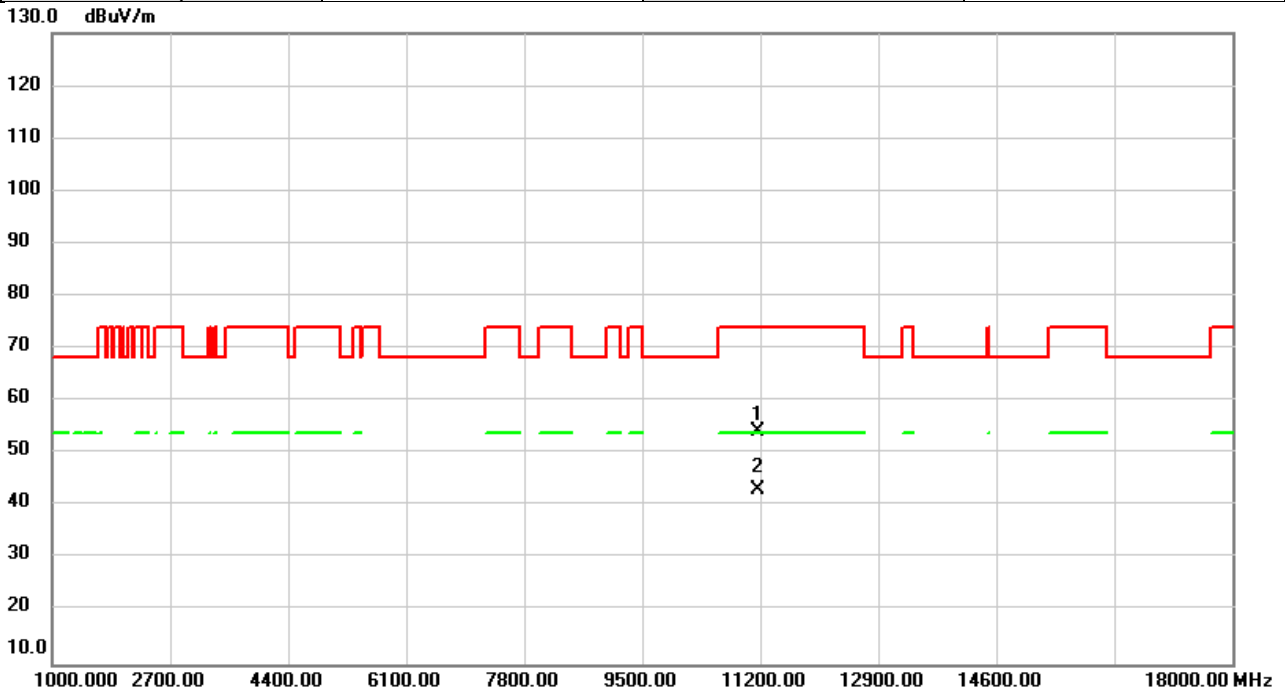

No.	Mk.	Freq.	Reading Level	Correct Factor	Measurement	Limit	Over	Detector	Comment
		MHz	dBuV	dB	dBuV/m	dBuV/m	dB		
1		11160.00	47.03	7.35	54.38	74.00	-19.62	peak	
2	*	11160.00	35.68	7.35	43.03	54.00	-10.97	AVG	

REMARKS:

- (1) Measurement Value = Reading Level + Correct Factor.
- (2) Margin Level = Measurement Value - Limit Value.

Test Mode	IEEE 802.11a	Test Date	2024/3/26
Test Frequency	5580MHz	Polarization	Horizontal
Temp	24°C	Hum.	64%

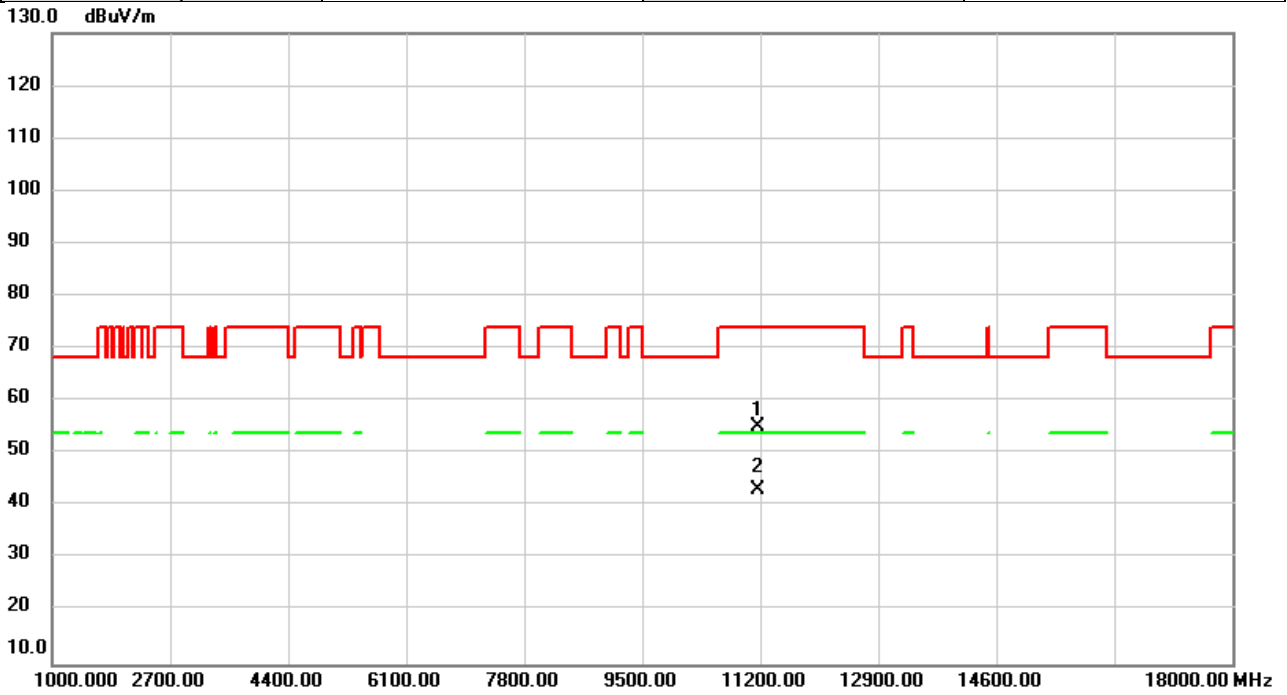

No.	Mk.	Freq. MHz	Reading Level dBuV	Correct Factor dB	Measure- ment dBuV/m	Limit dBuV/m	Over dB	Detector	Comment
1		11160.00	47.71	7.35	55.06	74.00	-18.94	peak	
2	*	11160.00	35.81	7.35	43.16	54.00	-10.84	AVG	

REMARKS:

- (1) Measurement Value = Reading Level + Correct Factor.
- (2) Margin Level = Measurement Value - Limit Value.

Test Mode	IEEE 802.11a	Test Date	2024/3/26
Test Frequency	5700MHz	Polarization	Vertical
Temp	24°C	Hum.	64%

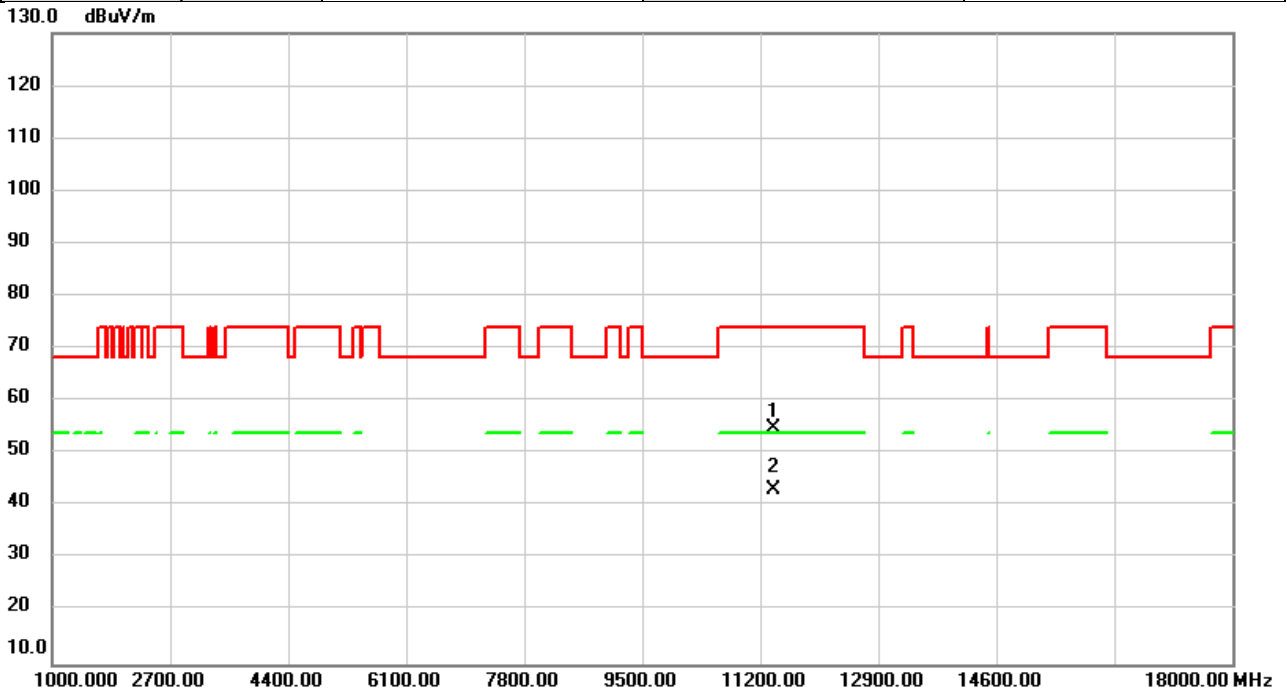

No.	Mk.	Freq. MHz	Reading Level dBuV	Correct Factor dB	Measure- ment dBuV/m	Limit dBuV/m	Over dB	Detector	Comment
1		11400.00	47.27	7.58	54.85	74.00	-19.15	peak	
2	*	11400.00	35.72	7.58	43.30	54.00	-10.70	AVG	

REMARKS:

- (1) Measurement Value = Reading Level + Correct Factor.
- (2) Margin Level = Measurement Value - Limit Value.

Test Mode	IEEE 802.11a	Test Date	2024/3/26
Test Frequency	5700MHz	Polarization	Horizontal
Temp	24°C	Hum.	64%

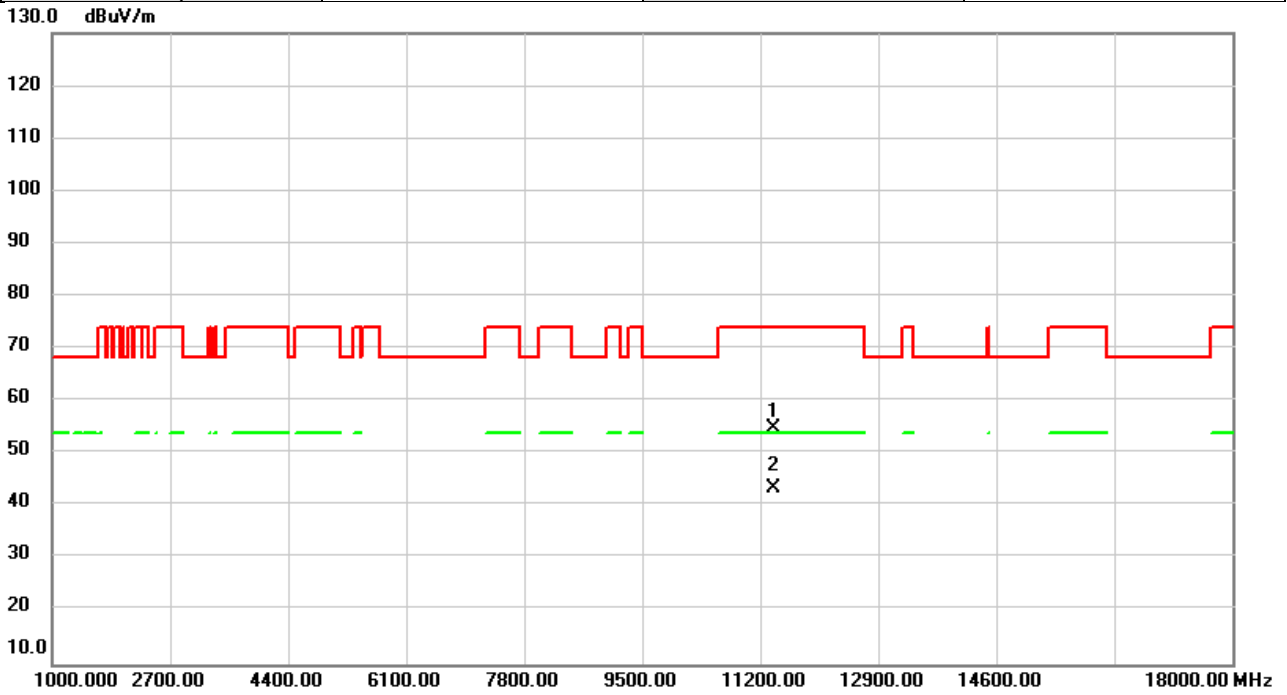

No.	Mk.	Freq.	Reading Level	Correct Factor	Measurement	Limit	Over	Detector	Comment
		MHz	dBuV	dB	dBuV/m	dBuV/m	dB		
1		11400.00	47.34	7.58	54.92	74.00	-19.08	peak	
2	*	11400.00	35.78	7.58	43.36	54.00	-10.64	AVG	

REMARKS:

- (1) Measurement Value = Reading Level + Correct Factor.
- (2) Margin Level = Measurement Value - Limit Value.

Test Mode	IEEE 802.11a	Test Date	2024/3/26
Test Frequency	5745MHz	Polarization	Vertical
Temp	24°C	Hum.	64%

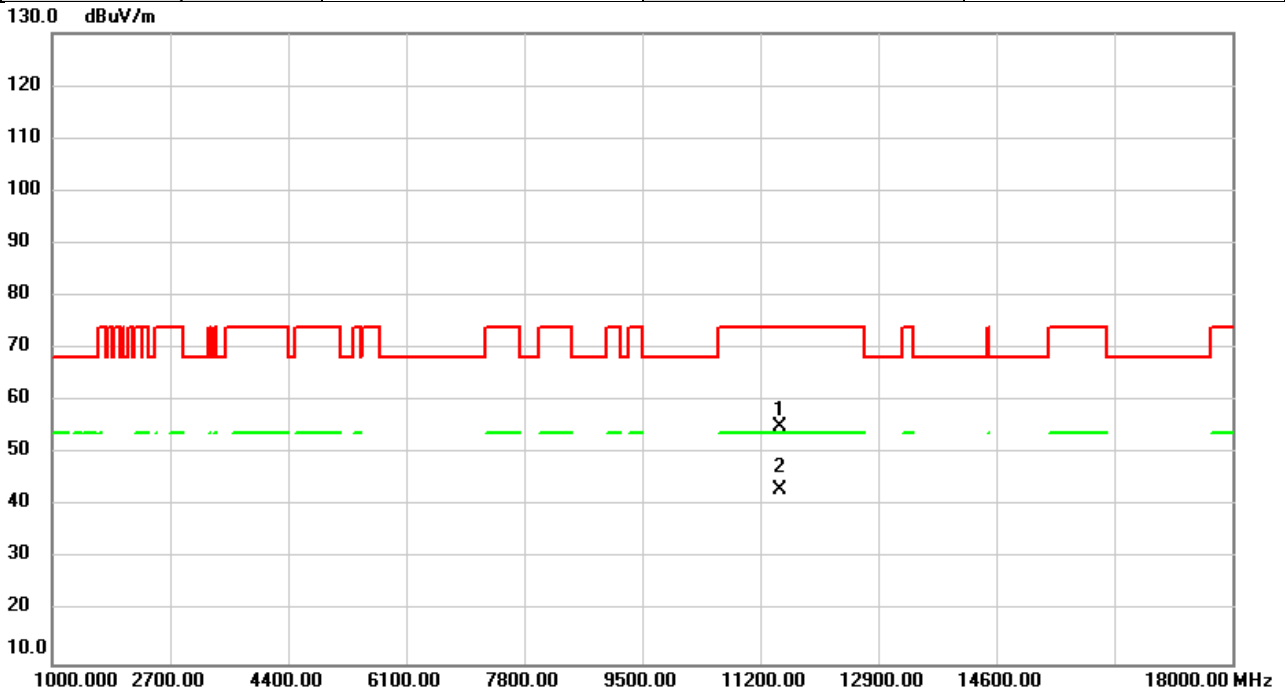

No.	Mk.	Freq.	Reading Level	Correct Factor	Measurement	Limit	Over	Detector	Comment
		MHz	dBuV	dB	dBuV/m	dBuV/m	dB		
1		11490.00	47.58	7.66	55.24	74.00	-18.76	peak	
2	*	11490.00	35.39	7.66	43.05	54.00	-10.95	AVG	

REMARKS:

- (1) Measurement Value = Reading Level + Correct Factor.
- (2) Margin Level = Measurement Value - Limit Value.

Test Mode	IEEE 802.11a	Test Date	2024/3/26
Test Frequency	5745MHz	Polarization	Horizontal
Temp	24°C	Hum.	64%

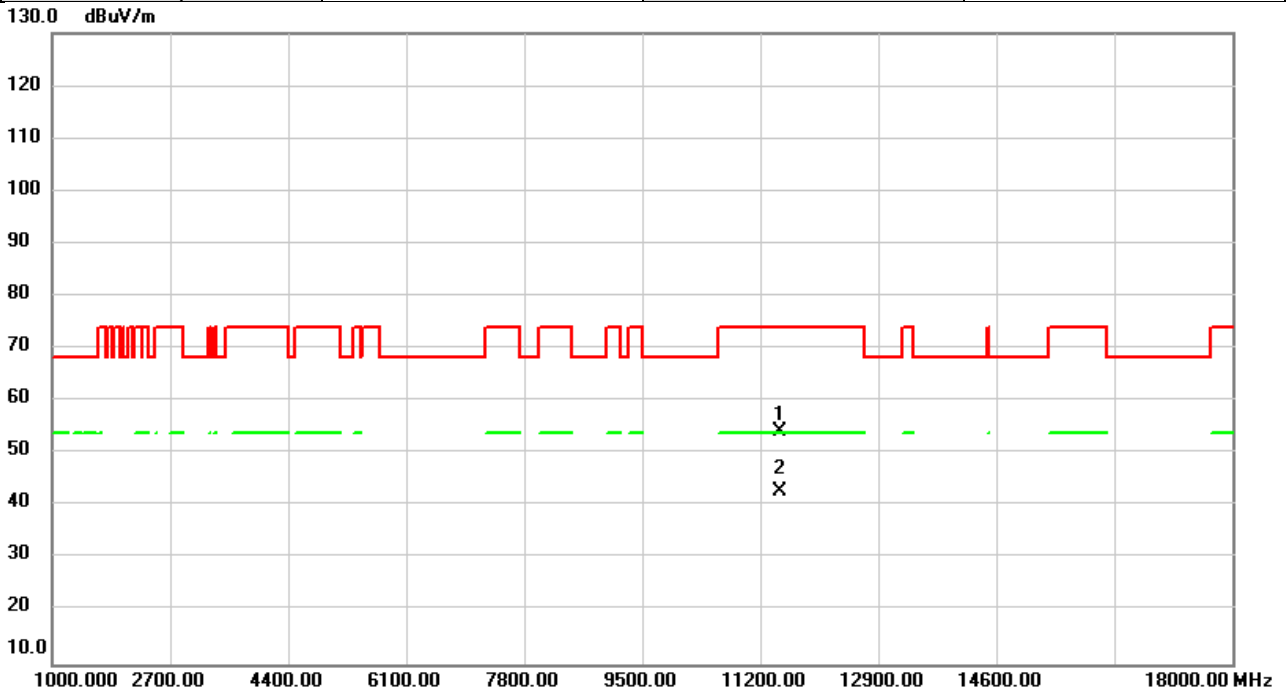

No.	Mk.	Freq.	Reading Level	Correct Factor	Measurement	Limit	Over	Detector	Comment
		MHz	dBuV	dB	dBuV/m	dBuV/m	dB		
1		11490.00	46.51	7.66	54.17	74.00	-19.83	peak	
2	*	11490.00	35.23	7.66	42.89	54.00	-11.11	AVG	

REMARKS:

- (1) Measurement Value = Reading Level + Correct Factor.
- (2) Margin Level = Measurement Value - Limit Value.

Test Mode	IEEE 802.11a	Test Date	2024/3/26
Test Frequency	5785MHz	Polarization	Vertical
Temp	24°C	Hum.	64%

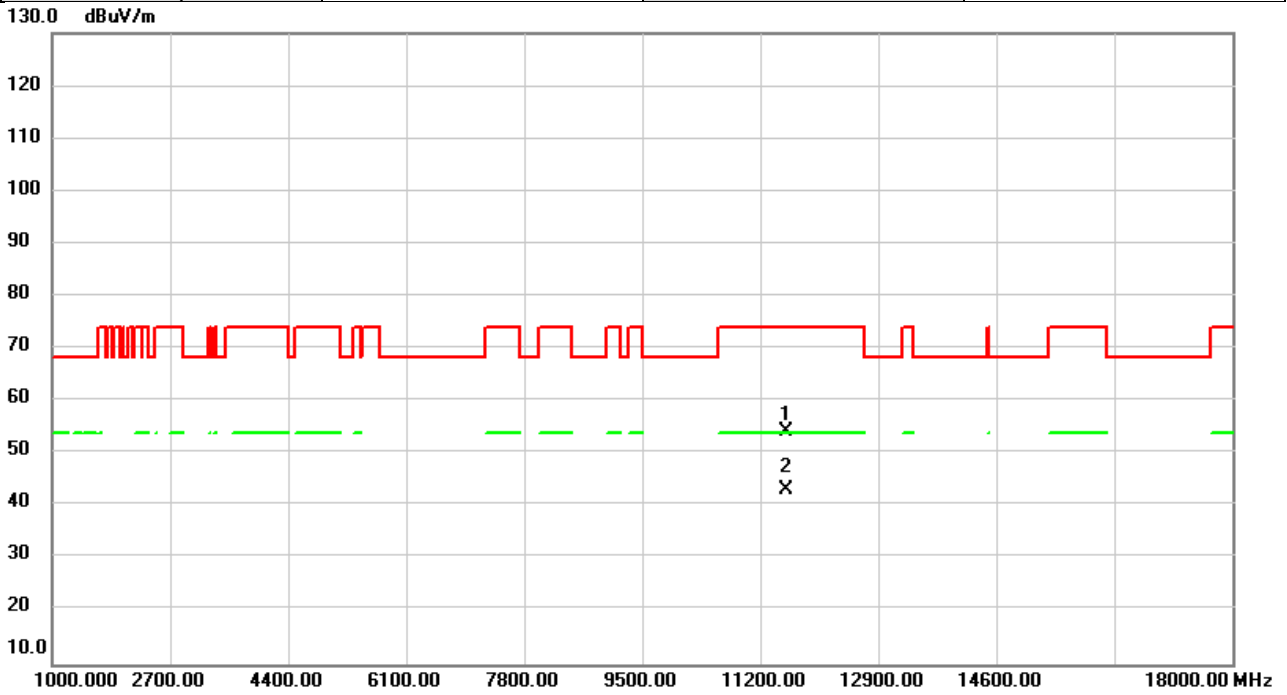

No.	Mk.	Freq.	Reading Level	Correct Factor	Measurement	Limit	Over	Detector	Comment
		MHz	dBuV	dB	dBuV/m	dBuV/m	dB		
1		11570.00	46.57	7.69	54.26	74.00	-19.74	peak	
2	*	11570.00	35.51	7.69	43.20	54.00	-10.80	AVG	

REMARKS:

- (1) Measurement Value = Reading Level + Correct Factor.
- (2) Margin Level = Measurement Value - Limit Value.

Test Mode	IEEE 802.11a	Test Date	2024/3/26
Test Frequency	5785MHz	Polarization	Horizontal
Temp	24°C	Hum.	64%

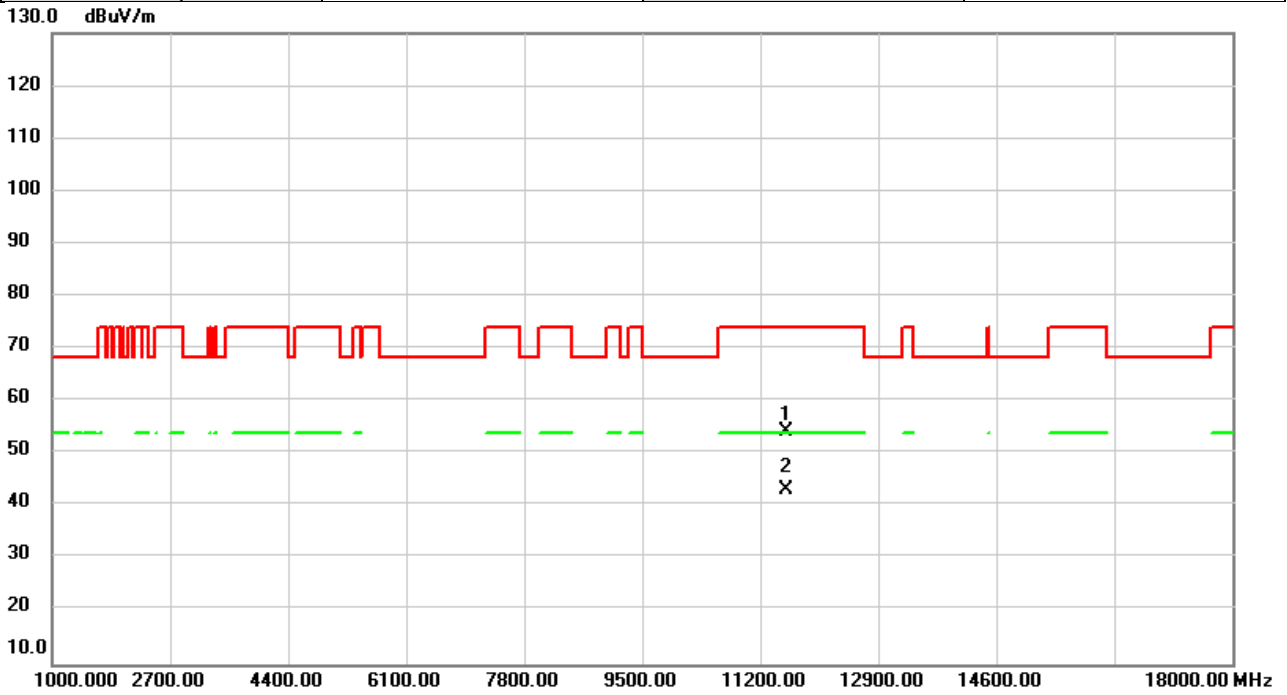

No.	Mk.	Freq.	Reading Level	Correct Factor	Measurement	Limit	Over	Detector	Comment
		MHz	dBuV	dB	dBuV/m	dBuV/m	dB		
1		11570.00	46.66	7.69	54.35	74.00	-19.65	peak	
2	*	11570.00	35.57	7.69	43.26	54.00	-10.74	AVG	

REMARKS:

- (1) Measurement Value = Reading Level + Correct Factor.
- (2) Margin Level = Measurement Value - Limit Value.

Test Mode	IEEE 802.11a	Test Date	2024/3/26
Test Frequency	5825MHz	Polarization	Vertical
Temp	24°C	Hum.	64%

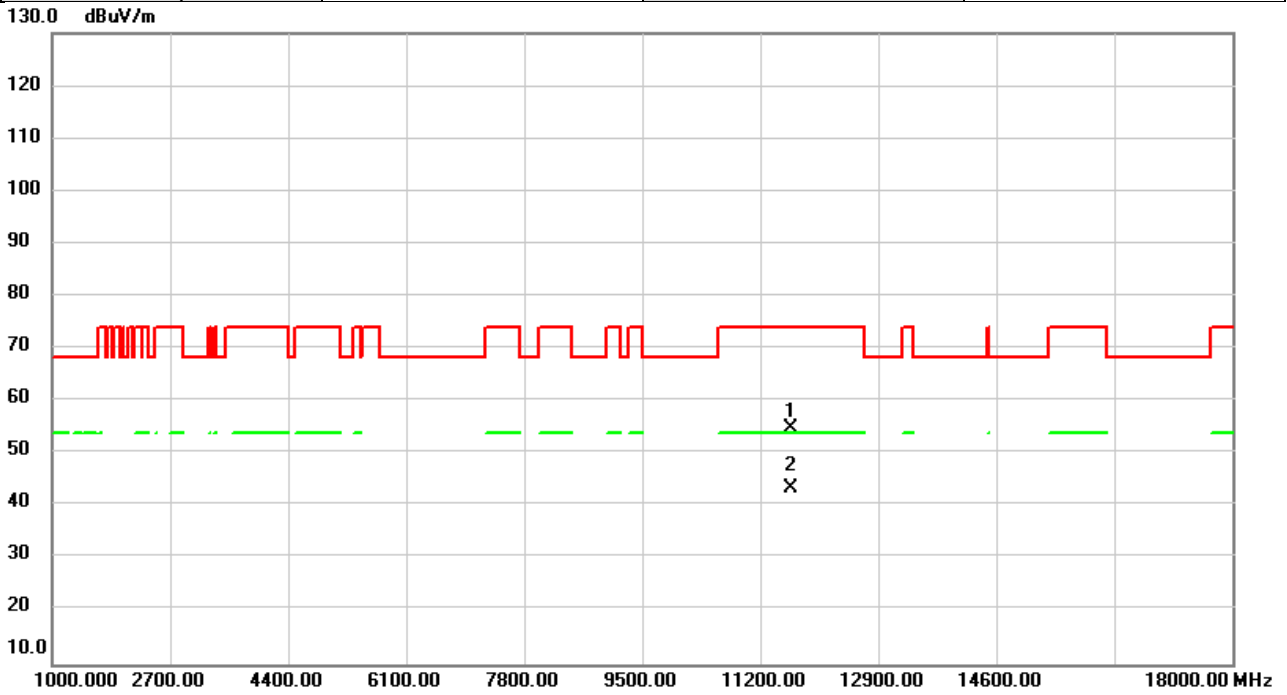

No.	Mk.	Freq.	Reading Level	Correct Factor	Measurement	Limit	Over	Detector	Comment
		MHz	dBuV	dB	dBuV/m	dBuV/m	dB		
1		11650.00	46.99	7.72	54.71	74.00	-19.29	peak	
2	*	11650.00	35.83	7.72	43.55	54.00	-10.45	AVG	

REMARKS:

- (1) Measurement Value = Reading Level + Correct Factor.
- (2) Margin Level = Measurement Value - Limit Value.

Test Mode	IEEE 802.11a	Test Date	2024/3/26
Test Frequency	5825MHz	Polarization	Horizontal
Temp	24°C	Hum.	64%

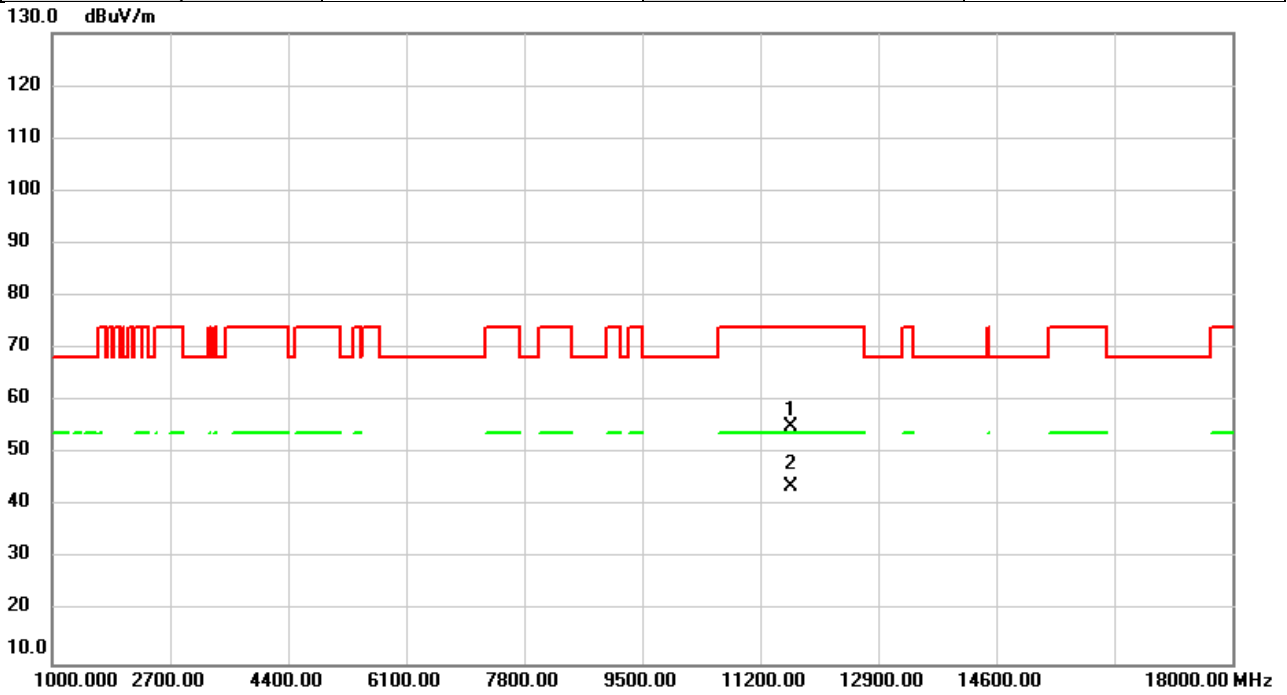

No.	Mk.	Freq. MHz	Reading Level dBuV	Correct Factor dB	Measure- ment dBuV/m	Limit dBuV/m	Over dB	Detector	Comment
1		11650.00	47.34	7.72	55.06	74.00	-18.94	peak	
2	*	11650.00	35.91	7.72	43.63	54.00	-10.37	AVG	

REMARKS:

- (1) Measurement Value = Reading Level + Correct Factor.
- (2) Margin Level = Measurement Value - Limit Value.

Test Mode	IEEE 802.11n (HT20)	Test Date	2024/3/26
Test Frequency	5180MHz	Polarization	Vertical
Temp	24°C	Hum.	64%

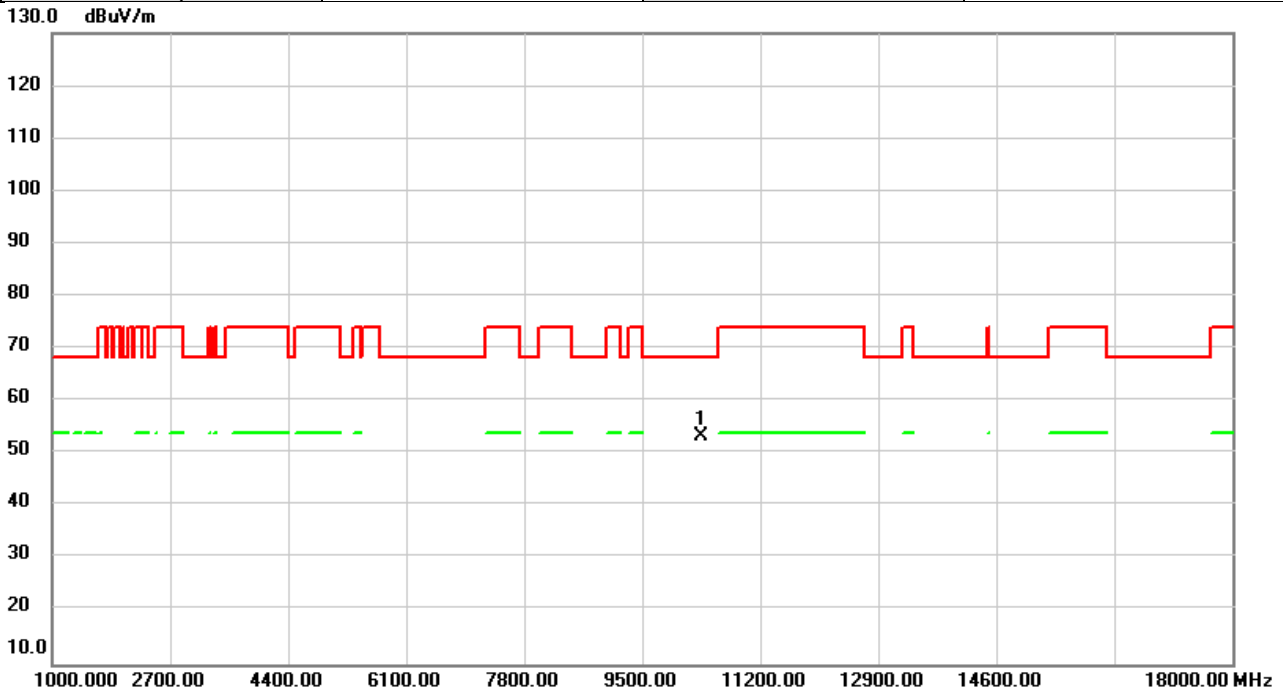

No.	Mk.	Freq.	Reading Level	Correct Factor	Measurement	Limit	Over	Detector	Comment
		MHz	dBuV	dB	dBuV/m	dBuV/m	dB		
1	*	10360.00	46.72	6.66	53.38	68.20	-14.82	peak	

REMARKS:

- (1) Measurement Value = Reading Level + Correct Factor.
- (2) Margin Level = Measurement Value - Limit Value.

Test Mode	IEEE 802.11n (HT20)	Test Date	2024/3/26
Test Frequency	5180MHz	Polarization	Horizontal
Temp	24°C	Hum.	64%

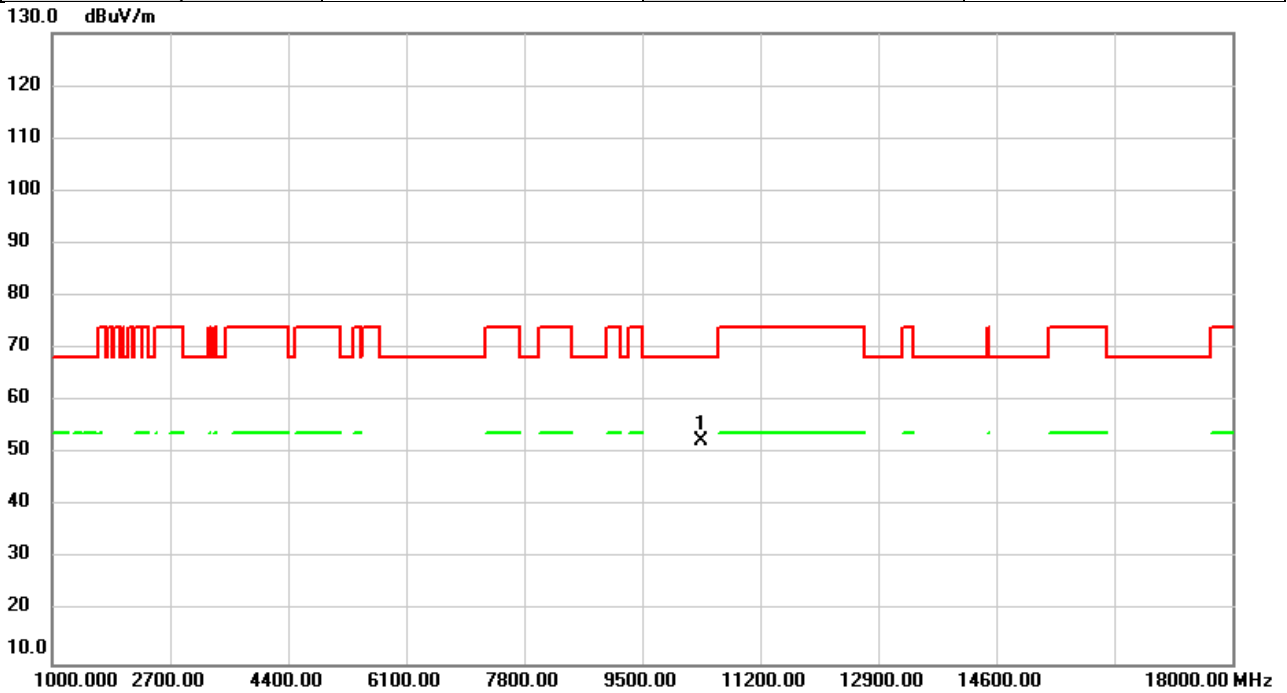

No.	Mk.	Freq.	Reading Level	Correct Factor	Measurement	Limit	Over	Detector	Comment
		MHz	dBuV	dB	dBuV/m	dBuV/m	dB		
1	*	10360.00	45.84	6.66	52.50	68.20	-15.70	peak	

REMARKS:

- (1) Measurement Value = Reading Level + Correct Factor.
- (2) Margin Level = Measurement Value - Limit Value.

Test Mode	IEEE 802.11n (HT20)	Test Date	2024/3/26
Test Frequency	5200MHz	Polarization	Vertical
Temp	24°C	Hum.	64%

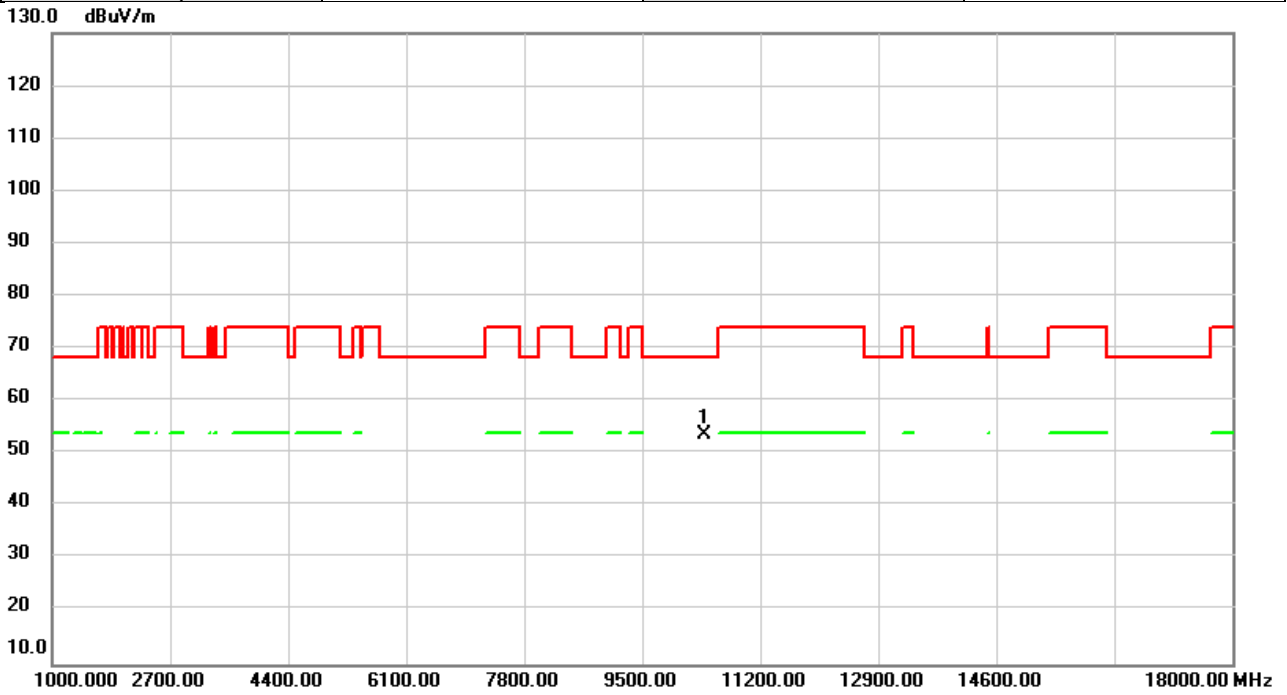

No.	Mk.	Freq.	Reading Level	Correct Factor	Measurement	Limit	Over	Detector	Comment
		MHz	dBuV	dB	dBuV/m	dBuV/m	dB		
1	*	10400.00	47.08	6.68	53.76	68.20	-14.44	peak	

REMARKS:

- (1) Measurement Value = Reading Level + Correct Factor.
- (2) Margin Level = Measurement Value - Limit Value.

Test Mode	IEEE 802.11n (HT20)	Test Date	2024/3/26
Test Frequency	5200MHz	Polarization	Horizontal
Temp	24°C	Hum.	64%

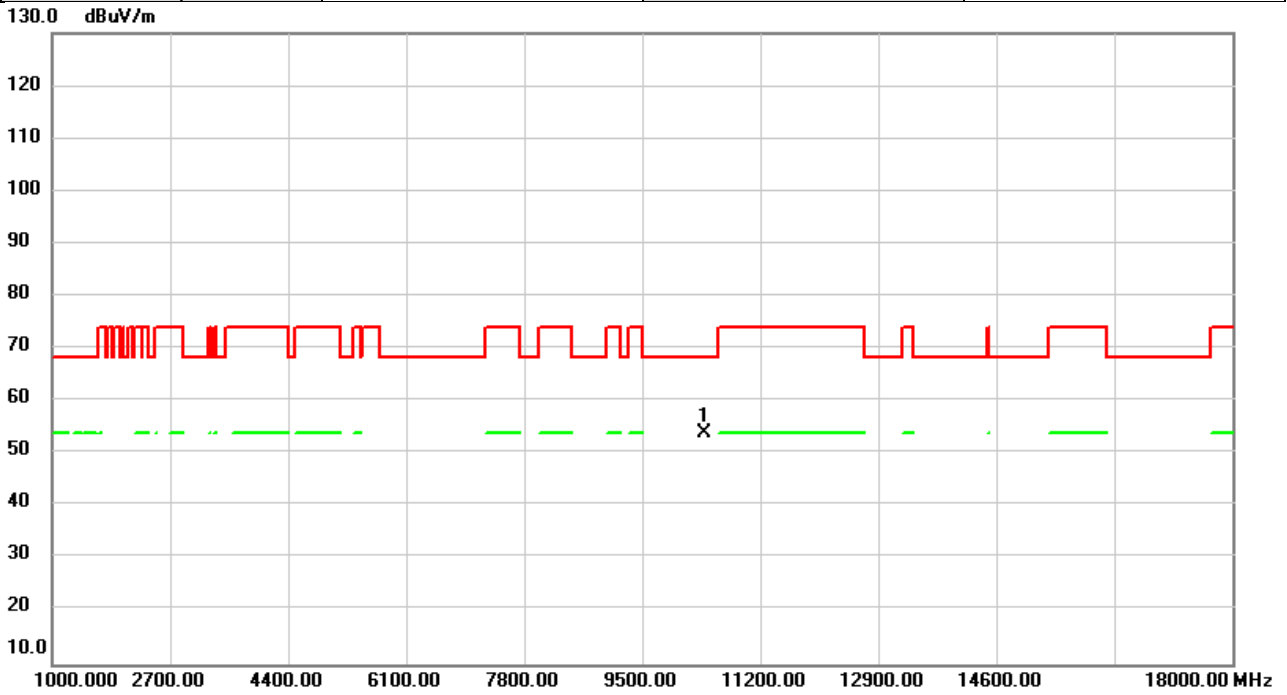

No.	Mk.	Freq.	Reading Level	Correct Factor	Measurement	Limit	Over	Detector	Comment
		MHz	dBuV	dB	dBuV/m	dBuV/m	dB		
1	*	10400.00	47.20	6.68	53.88	68.20	-14.32	peak	

REMARKS:

- (1) Measurement Value = Reading Level + Correct Factor.
- (2) Margin Level = Measurement Value - Limit Value.

Test Mode	IEEE 802.11n (HT20)	Test Date	2024/3/26
Test Frequency	5240MHz	Polarization	Vertical
Temp	24°C	Hum.	64%

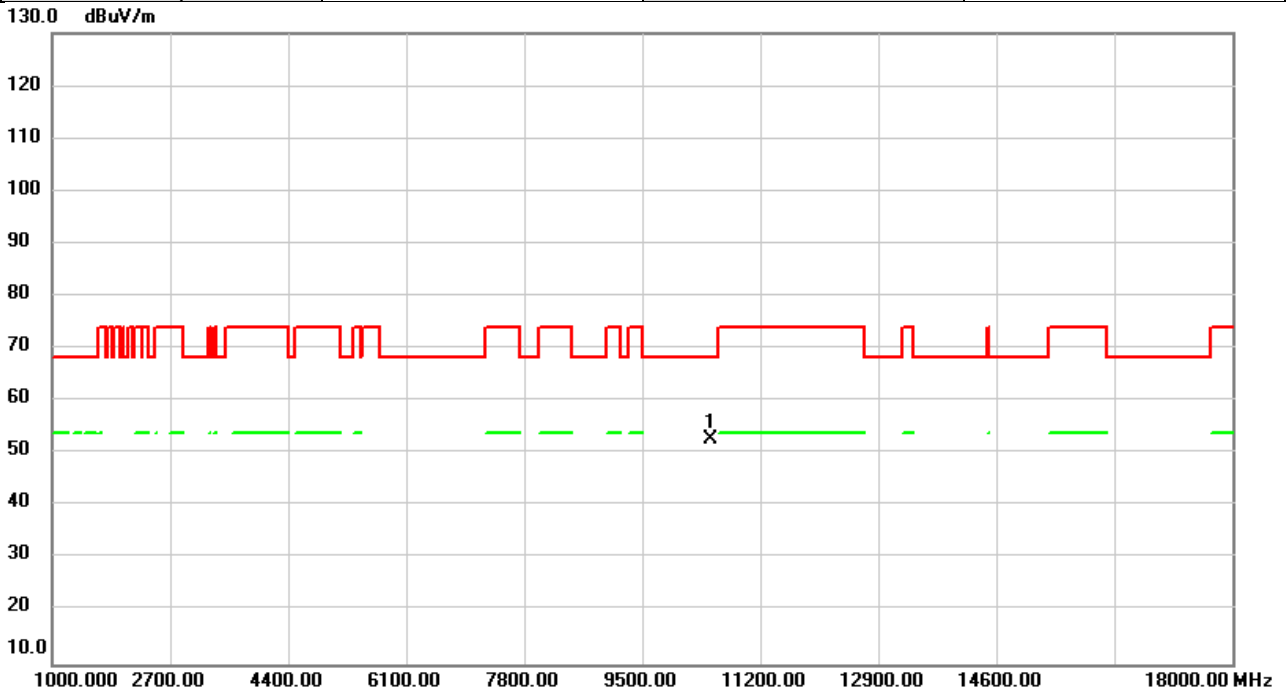

No.	Mk.	Freq.	Reading Level	Correct Factor	Measurement	Limit	Over	Detector	Comment
		MHz	dBuV	dB	dBuV/m	dBuV/m	dB		
1	*	10480.00	46.11	6.71	52.82	68.20	-15.38	peak	

REMARKS:

- (1) Measurement Value = Reading Level + Correct Factor.
- (2) Margin Level = Measurement Value - Limit Value.

Test Mode	IEEE 802.11n (HT20)	Test Date	2024/3/26
Test Frequency	5240MHz	Polarization	Horizontal
Temp	24°C	Hum.	64%

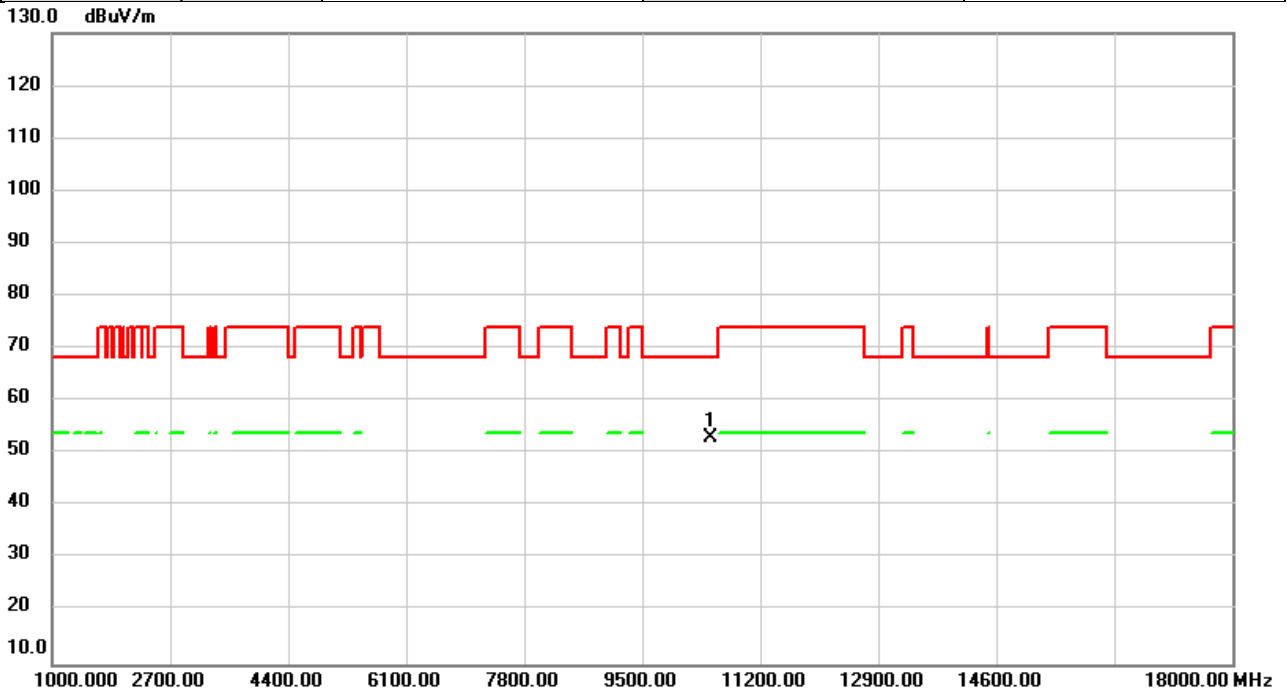

No.	Mk.	Freq.	Reading Level	Correct Factor	Measurement	Limit	Over	Detector	Comment
		MHz	dBuV	dB	dBuV/m	dBuV/m	dB		
1	*	10480.00	46.48	6.71	53.19	68.20	-15.01	peak	

REMARKS:

- (1) Measurement Value = Reading Level + Correct Factor.
- (2) Margin Level = Measurement Value - Limit Value.

Test Mode	IEEE 802.11n (HT20)	Test Date	2024/3/26
Test Frequency	5260MHz	Polarization	Vertical
Temp	24°C	Hum.	64%

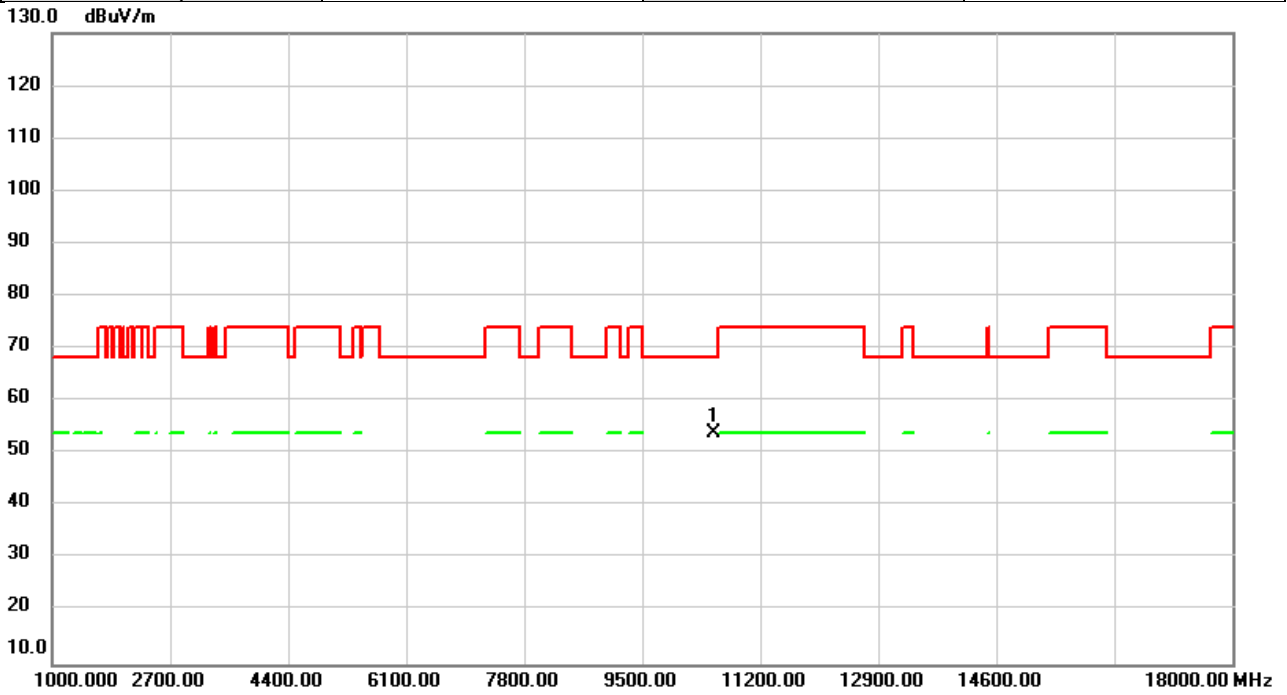

No.	Mk.	Freq.	Reading Level	Correct Factor	Measurement	Limit	Over	Detector	Comment
		MHz	dBuV	dB	dBuV/m	dBuV/m	dB		
1	*	10520.00	47.21	6.73	53.94	68.20	-14.26	peak	

REMARKS:

- (1) Measurement Value = Reading Level + Correct Factor.
- (2) Margin Level = Measurement Value - Limit Value.

Test Mode	IEEE 802.11n (HT20)	Test Date	2024/3/26
Test Frequency	5260MHz	Polarization	Horizontal
Temp	24°C	Hum.	64%

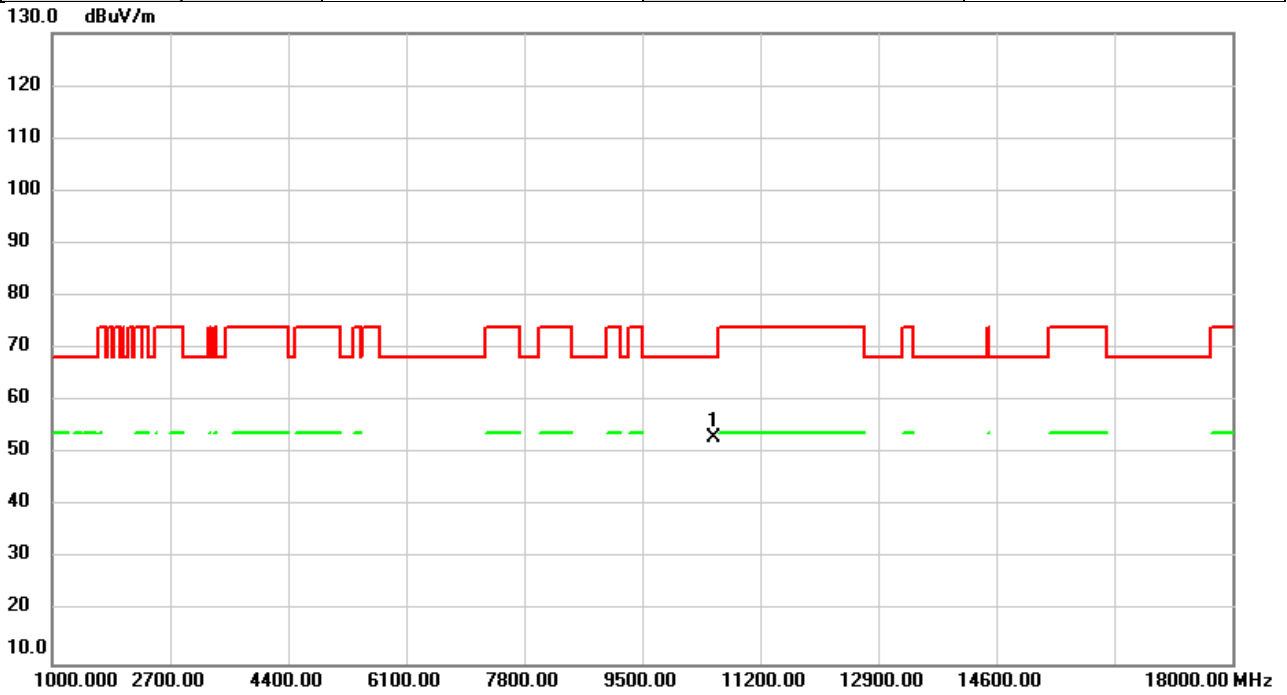

No.	Mk.	Freq.	Reading Level	Correct Factor	Measurement	Limit	Over	Detector	Comment
		MHz	dBuV	dB	dBuV/m	dBuV/m	dB		
1	*	10520.00	46.45	6.73	53.18	68.20	-15.02	peak	

REMARKS:

- (1) Measurement Value = Reading Level + Correct Factor.
- (2) Margin Level = Measurement Value - Limit Value.

Test Mode	IEEE 802.11n (HT20)	Test Date	2024/3/26
Test Frequency	5300MHz	Polarization	Vertical
Temp	24°C	Hum.	64%

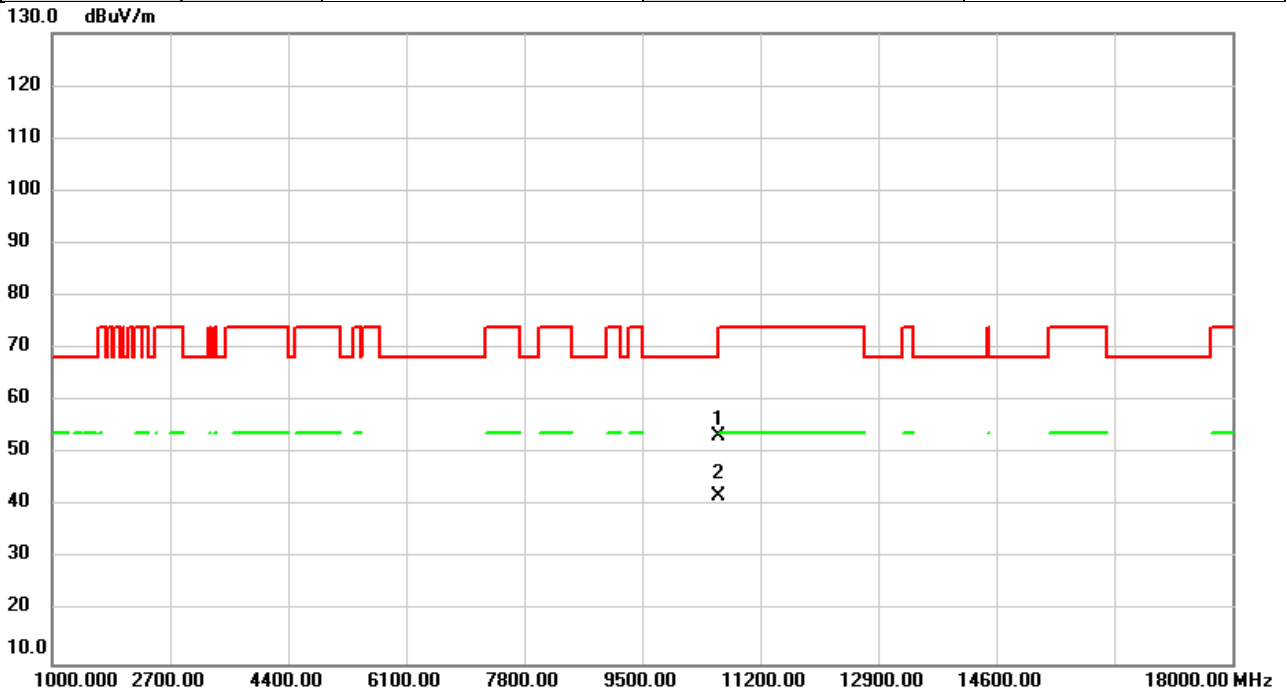

No.	Mk.	Freq.	Reading Level	Correct Factor	Measurement	Limit	Over	Detector	Comment
		MHz	dBuV	dB	dBuV/m	dBuV/m	dB		
1		10600.00	46.60	6.81	53.41	68.20	-14.79	peak	
2	*	10600.00	35.22	6.81	42.03	54.00	-11.97	AVG	

REMARKS:

- (1) Measurement Value = Reading Level + Correct Factor.
- (2) Margin Level = Measurement Value - Limit Value.

Test Mode	IEEE 802.11n (HT20)	Test Date	2024/3/26
Test Frequency	5300MHz	Polarization	Horizontal
Temp	24°C	Hum.	64%

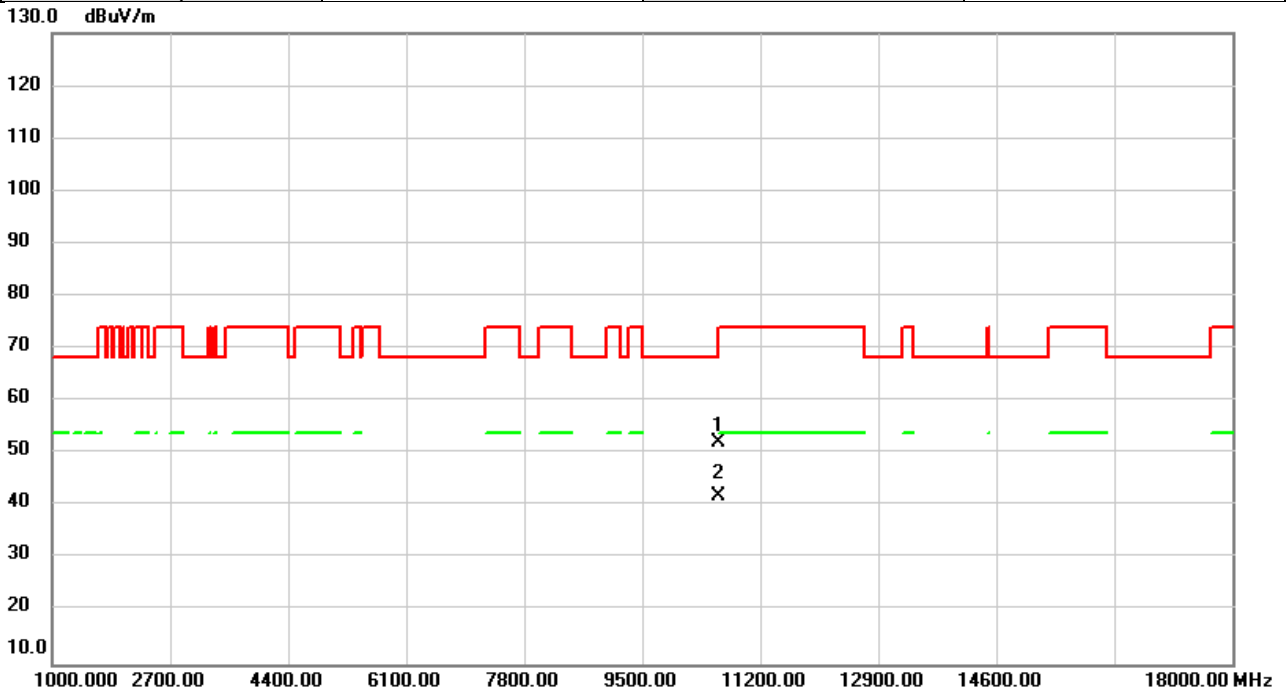

No.	Mk.	Freq.	Reading Level	Correct Factor	Measurement	Limit	Over	Detector	Comment
		MHz	dBuV	dB	dBuV/m	dBuV/m	dB		
1		10600.00	45.40	6.81	52.21	68.20	-15.99	peak	
2	*	10600.00	35.27	6.81	42.08	54.00	-11.92	AVG	

REMARKS:

- (1) Measurement Value = Reading Level + Correct Factor.
- (2) Margin Level = Measurement Value - Limit Value.

Test Mode	IEEE 802.11n (HT20)	Test Date	2024/3/26
Test Frequency	5320MHz	Polarization	Vertical
Temp	24°C	Hum.	64%

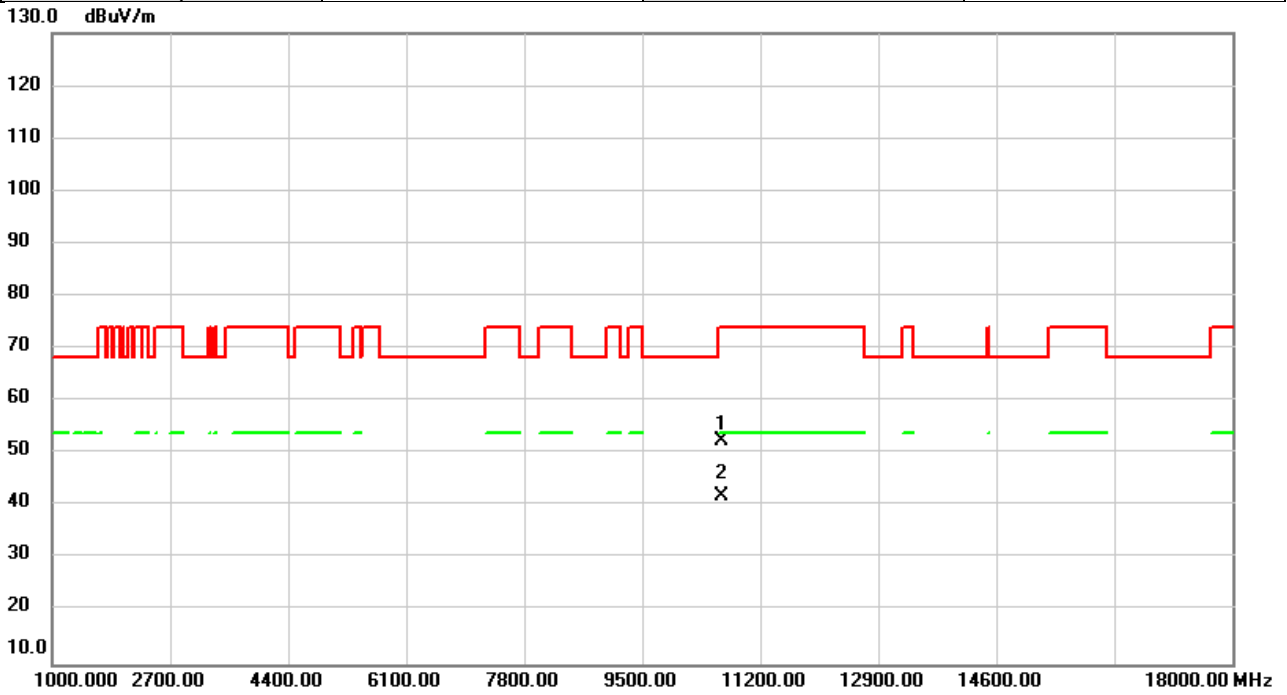

No.	Mk.	Freq. MHz	Reading Level dBuV	Correct Factor dB	Measure- ment dBuV/m	Limit dBuV/m	Over dB	Detector	Comment
1		10640.00	45.71	6.85	52.56	74.00	-21.44	peak	
2	*	10640.00	34.96	6.85	41.81	54.00	-12.19	AVG	

REMARKS:

- (1) Measurement Value = Reading Level + Correct Factor.
- (2) Margin Level = Measurement Value - Limit Value.

Test Mode	IEEE 802.11n (HT20)	Test Date	2024/3/26
Test Frequency	5320MHz	Polarization	Horizontal
Temp	24°C	Hum.	64%

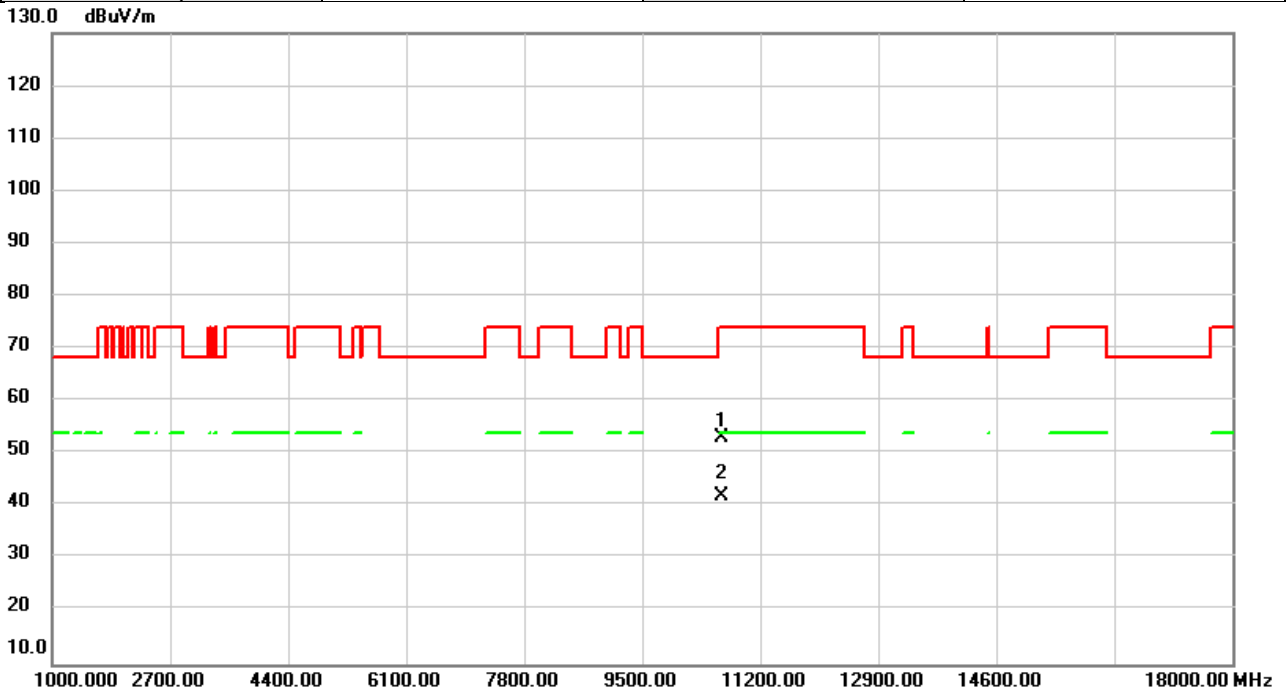

No.	Mk.	Freq.	Reading Level	Correct Factor	Measurement	Limit	Over	Detector	Comment
		MHz	dBuV	dB	dBuV/m	dBuV/m	dB		
1		10640.00	46.16	6.85	53.01	74.00	-20.99	peak	
2	*	10640.00	35.11	6.85	41.96	54.00	-12.04	AVG	

REMARKS:

- (1) Measurement Value = Reading Level + Correct Factor.
- (2) Margin Level = Measurement Value - Limit Value.

Test Mode	IEEE 802.11n (HT20)	Test Date	2024/3/26
Test Frequency	5500MHz	Polarization	Vertical
Temp	24°C	Hum.	64%

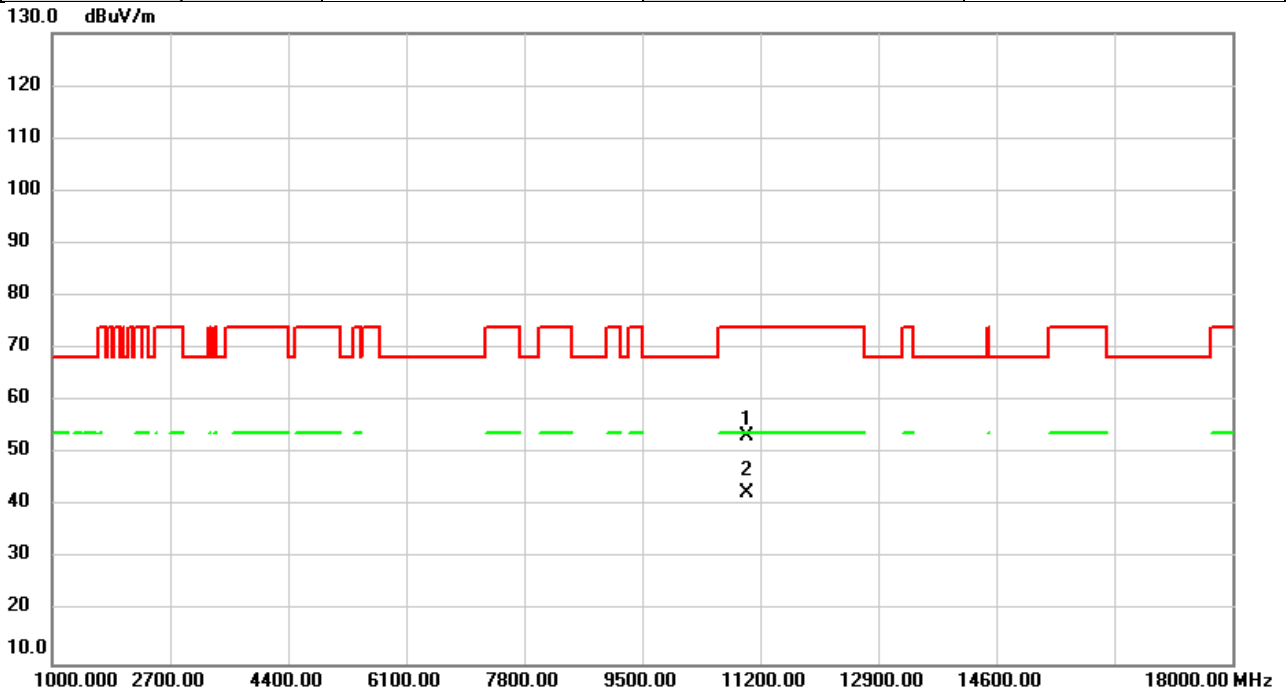

No.	Mk.	Freq.	Reading Level	Correct Factor	Measurement	Limit	Over	Detector	Comment
		MHz	dBuV	dB	dBuV/m	dBuV/m	dB		
1		11000.00	46.23	7.19	53.42	74.00	-20.58	peak	
2	*	11000.00	35.40	7.19	42.59	54.00	-11.41	AVG	

REMARKS:

- (1) Measurement Value = Reading Level + Correct Factor.
- (2) Margin Level = Measurement Value - Limit Value.

Test Mode	IEEE 802.11n (HT20)	Test Date	2024/3/26
Test Frequency	5500MHz	Polarization	Horizontal
Temp	24°C	Hum.	64%

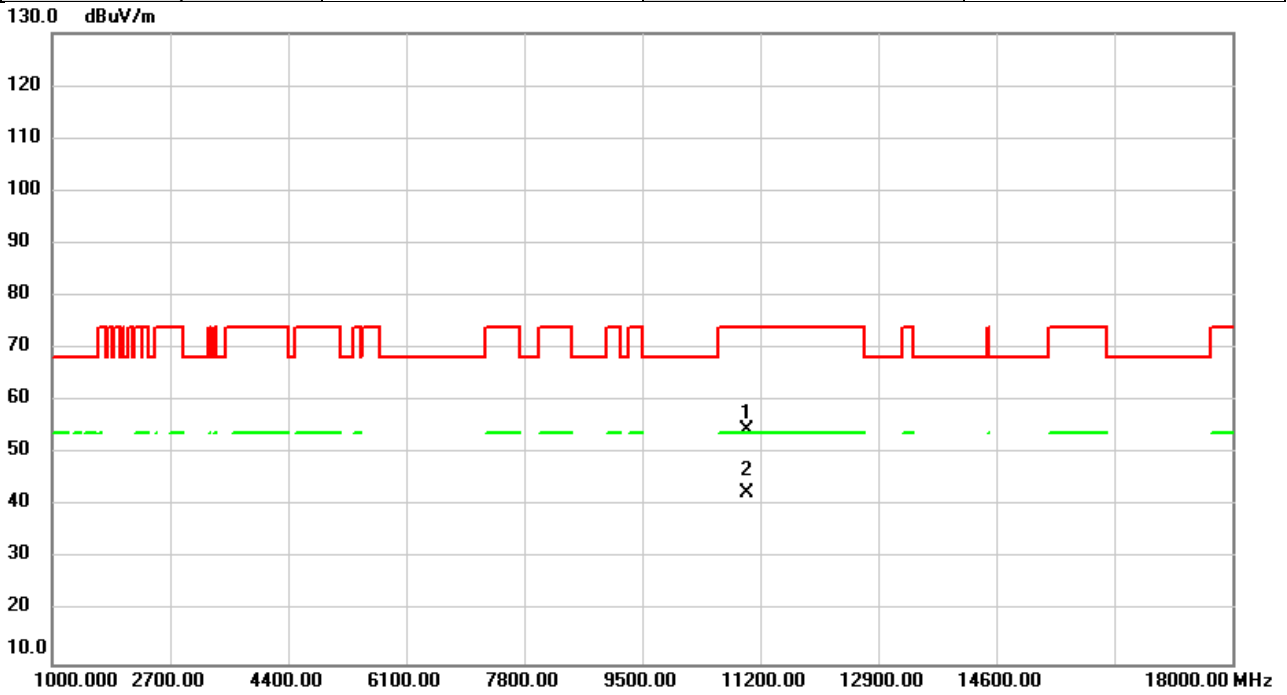

No.	Mk.	Freq. MHz	Reading Level dBuV	Correct Factor dB	Measure- ment dBuV/m	Limit dBuV/m	Over dB	Detector	Comment
1		11000.00	47.37	7.19	54.56	74.00	-19.44	peak	
2	*	11000.00	35.48	7.19	42.67	54.00	-11.33	AVG	

REMARKS:

- (1) Measurement Value = Reading Level + Correct Factor.
- (2) Margin Level = Measurement Value - Limit Value.

Test Mode	IEEE 802.11n (HT20)	Test Date	2024/3/26
Test Frequency	5580MHz	Polarization	Vertical
Temp	24°C	Hum.	64%

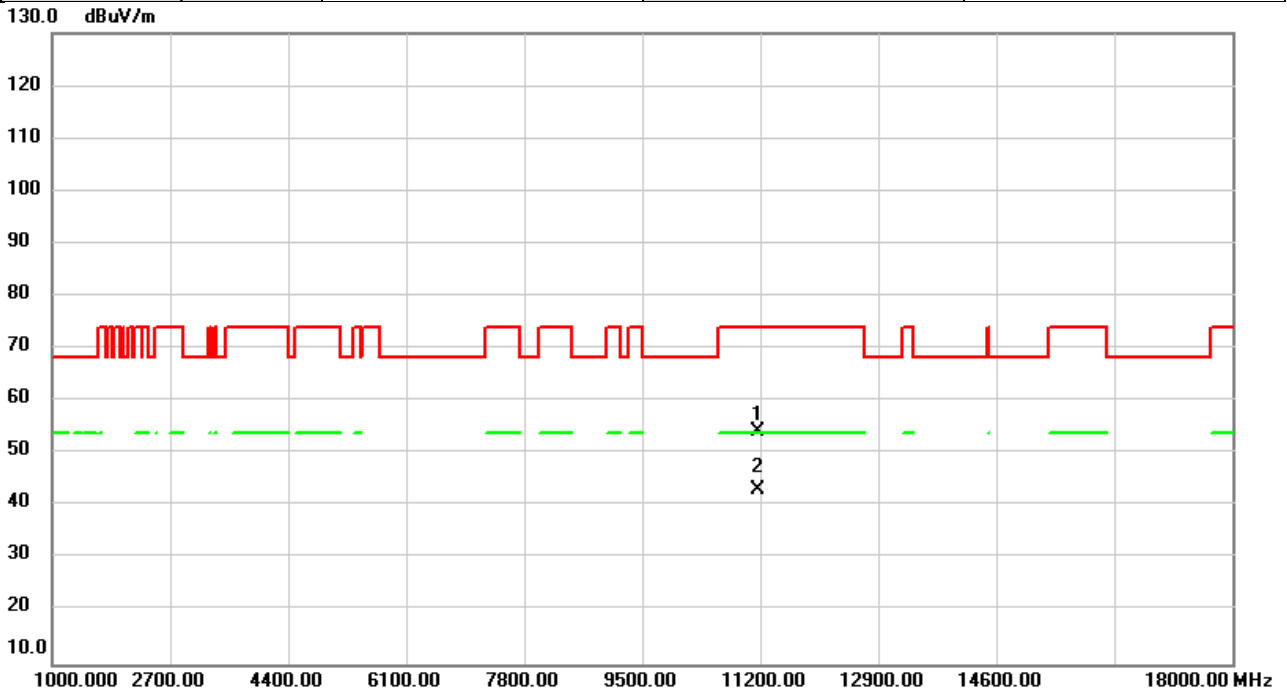

No.	Mk.	Freq. MHz	Reading Level dBuV	Correct Factor dB	Measure- ment dBuV/m	Limit dBuV/m	Over dB	Detector	Comment
1		11160.00	46.92	7.35	54.27	74.00	-19.73	peak	
2	*	11160.00	35.74	7.35	43.09	54.00	-10.91	AVG	

REMARKS:

- (1) Measurement Value = Reading Level + Correct Factor.
- (2) Margin Level = Measurement Value - Limit Value.

Test Mode	IEEE 802.11n (HT20)	Test Date	2024/3/26
Test Frequency	5580MHz	Polarization	Horizontal
Temp	24°C	Hum.	64%

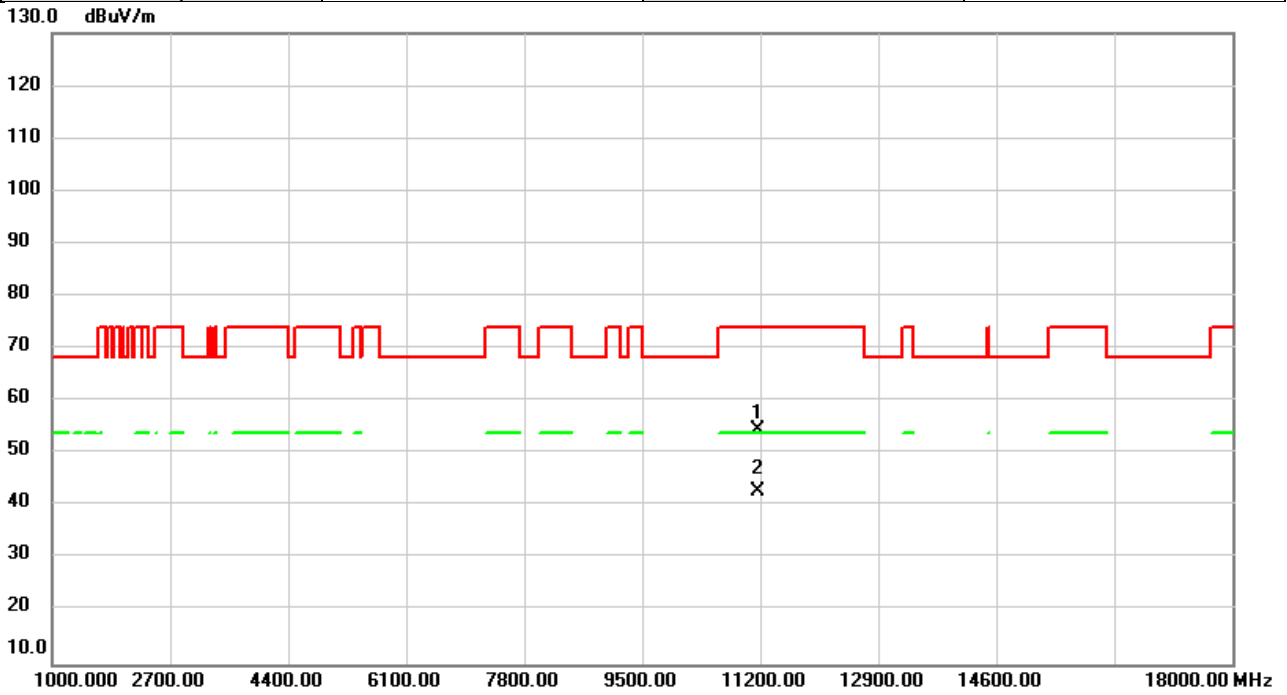

No.	Mk.	Freq.	Reading Level	Correct Factor	Measurement	Limit	Over	Detector	Comment
		MHz	dBuV	dB	dBuV/m	dBuV/m	dB		
1		11160.00	47.28	7.35	54.63	74.00	-19.37	peak	
2	*	11160.00	35.63	7.35	42.98	54.00	-11.02	AVG	

REMARKS:

- (1) Measurement Value = Reading Level + Correct Factor.
- (2) Margin Level = Measurement Value - Limit Value.

Test Mode	IEEE 802.11n (HT20)	Test Date	2024/3/26
Test Frequency	5700MHz	Polarization	Vertical
Temp	24°C	Hum.	64%

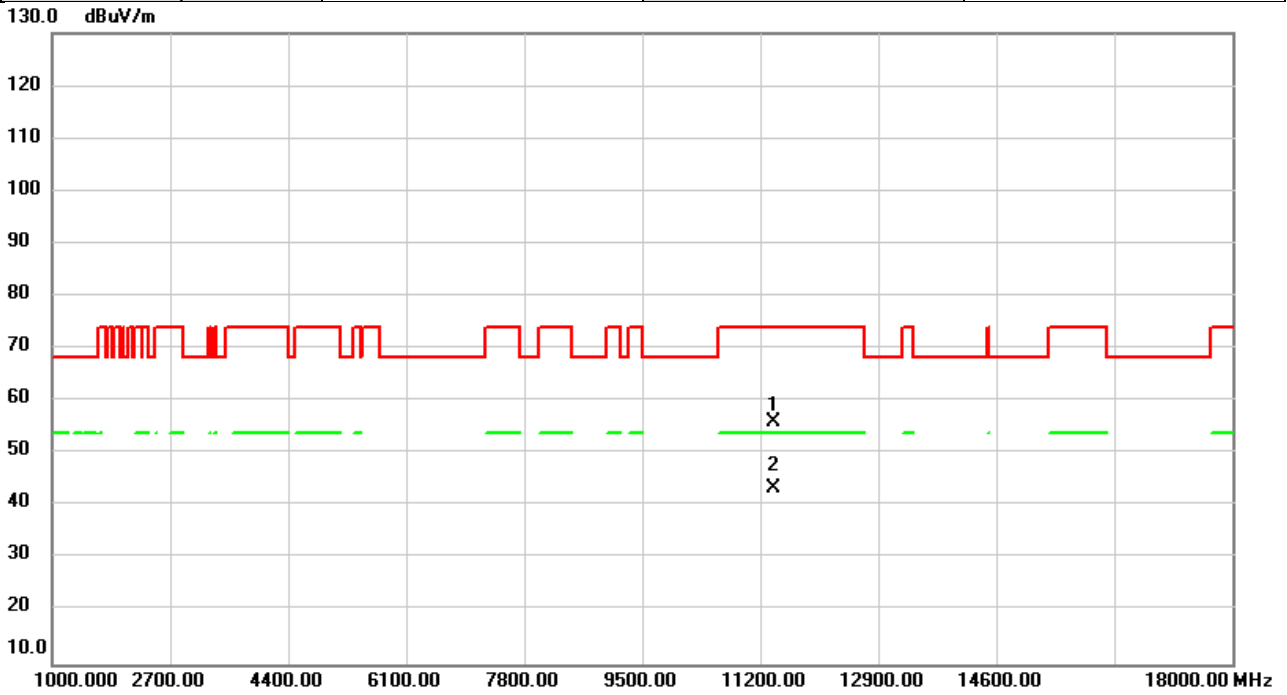

No.	Mk.	Freq.	Reading Level	Correct Factor	Measurement	Limit	Over	Detector	Comment
		MHz	dBuV	dB	dBuV/m	dBuV/m	dB		
1		11400.00	48.57	7.58	56.15	74.00	-17.85	peak	
2	*	11400.00	35.98	7.58	43.56	54.00	-10.44	AVG	

REMARKS:

- (1) Measurement Value = Reading Level + Correct Factor.
- (2) Margin Level = Measurement Value - Limit Value.

Test Mode	IEEE 802.11n (HT20)	Test Date	2024/3/26
Test Frequency	5700MHz	Polarization	Horizontal
Temp	24°C	Hum.	64%

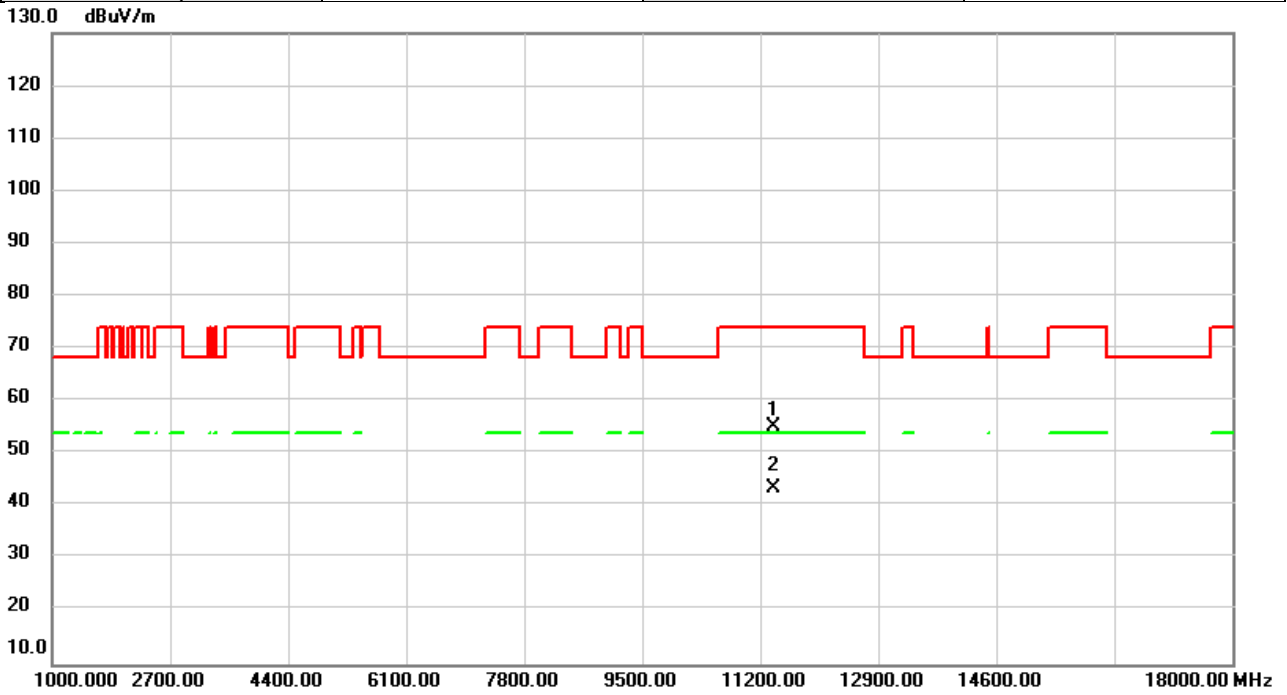

No.	Mk.	Freq. MHz	Reading Level dBuV	Correct Factor dB	Measure- ment dBuV/m	Limit dBuV/m	Over dB	Detector	Comment
1		11400.00	47.60	7.58	55.18	74.00	-18.82	peak	
2	*	11400.00	35.83	7.58	43.41	54.00	-10.59	AVG	

REMARKS:

- (1) Measurement Value = Reading Level + Correct Factor.
- (2) Margin Level = Measurement Value - Limit Value.

Test Mode	IEEE 802.11n (HT20)	Test Date	2024/3/26
Test Frequency	5745MHz	Polarization	Vertical
Temp	24°C	Hum.	64%

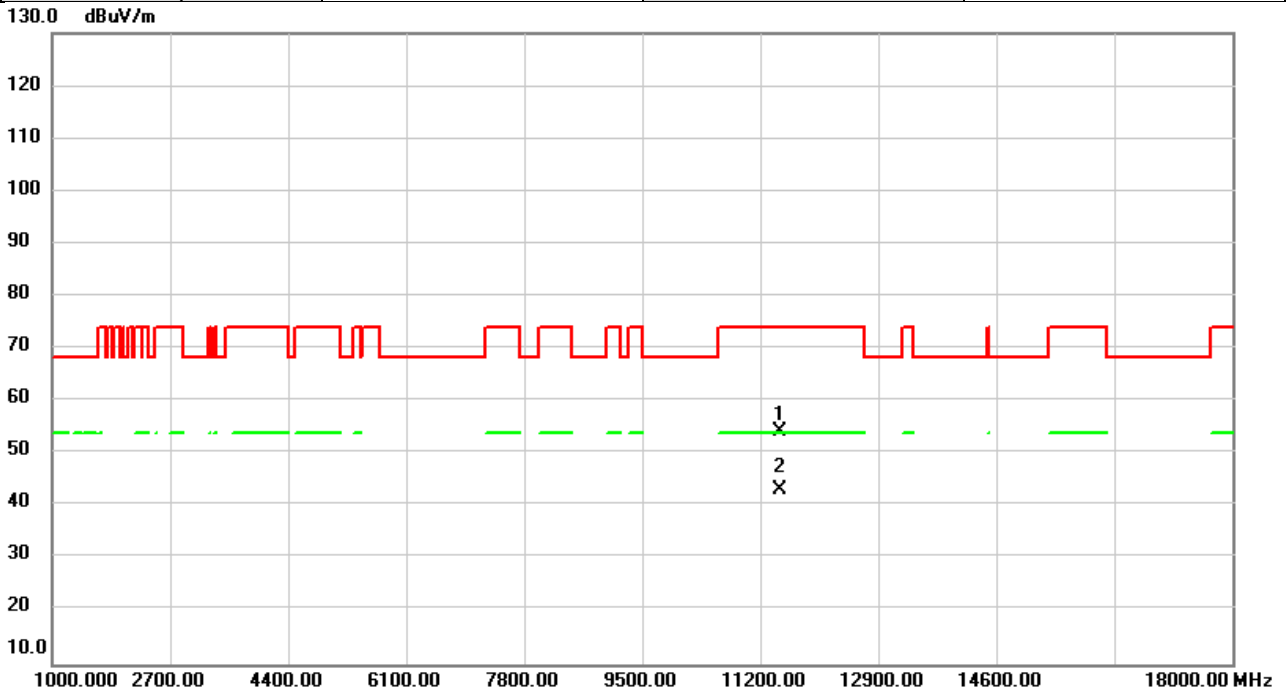

No.	Mk.	Freq.	Reading Level	Correct Factor	Measurement	Limit	Over	Detector	Comment
		MHz	dBuV	dB	dBuV/m	dBuV/m	dB		
1		11490.00	46.71	7.66	54.37	74.00	-19.63	peak	
2	*	11490.00	35.39	7.66	43.05	54.00	-10.95	AVG	

REMARKS:

- (1) Measurement Value = Reading Level + Correct Factor.
- (2) Margin Level = Measurement Value - Limit Value.

Test Mode	IEEE 802.11n (HT20)	Test Date	2024/3/26
Test Frequency	5745MHz	Polarization	Horizontal
Temp	24°C	Hum.	64%

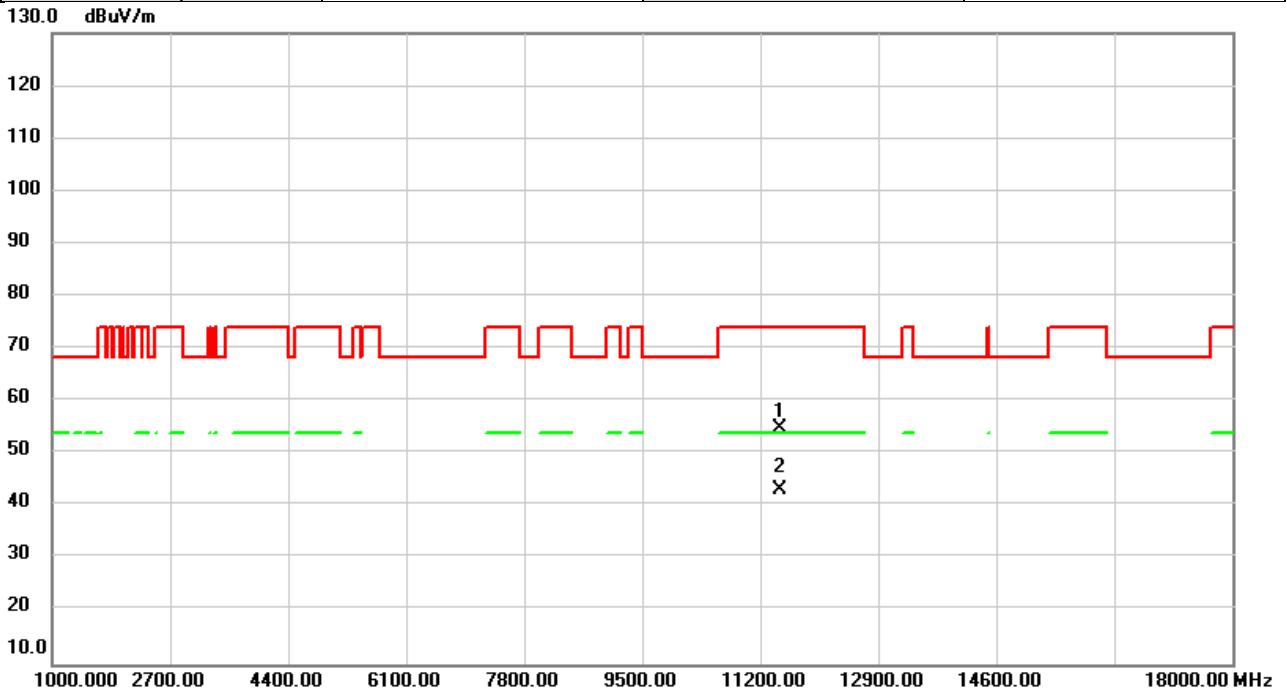

No.	Mk.	Freq. MHz	Reading Level dBuV	Correct Factor dB	Measure- ment dBuV/m	Limit dBuV/m	Over dB	Detector	Comment
1		11490.00	47.07	7.66	54.73	74.00	-19.27	peak	
2	*	11490.00	35.37	7.66	43.03	54.00	-10.97	AVG	

REMARKS:

- (1) Measurement Value = Reading Level + Correct Factor.
- (2) Margin Level = Measurement Value - Limit Value.

Test Mode	IEEE 802.11n (HT20)	Test Date	2024/3/26
Test Frequency	5785MHz	Polarization	Vertical
Temp	24°C	Hum.	64%

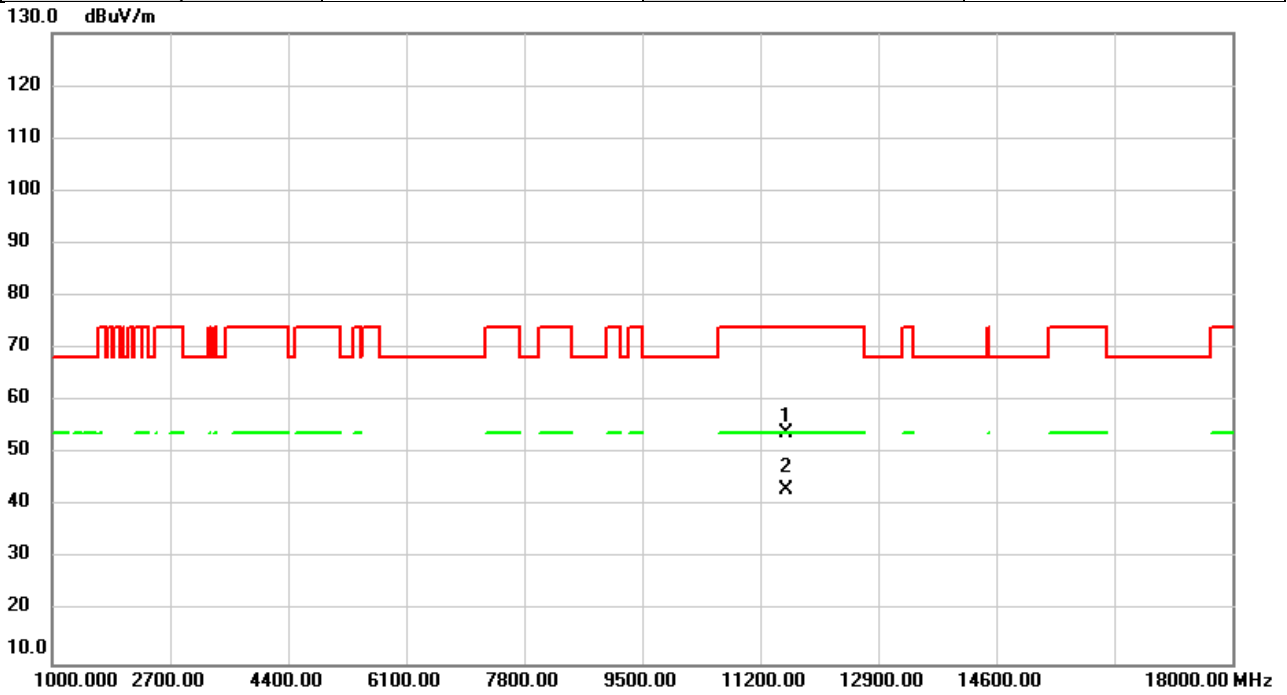

No.	Mk.	Freq. MHz	Reading Level dBuV	Correct Factor dB	Measure- ment dBuV/m	Limit dBuV/m	Over dB	Detector	Comment
1		11570.00	46.29	7.69	53.98	74.00	-20.02	peak	
2	*	11570.00	35.53	7.69	43.22	54.00	-10.78	AVG	

REMARKS:

- (1) Measurement Value = Reading Level + Correct Factor.
- (2) Margin Level = Measurement Value - Limit Value.

Test Mode	IEEE 802.11n (HT20)	Test Date	2024/3/26
Test Frequency	5785MHz	Polarization	Horizontal
Temp	24°C	Hum.	64%

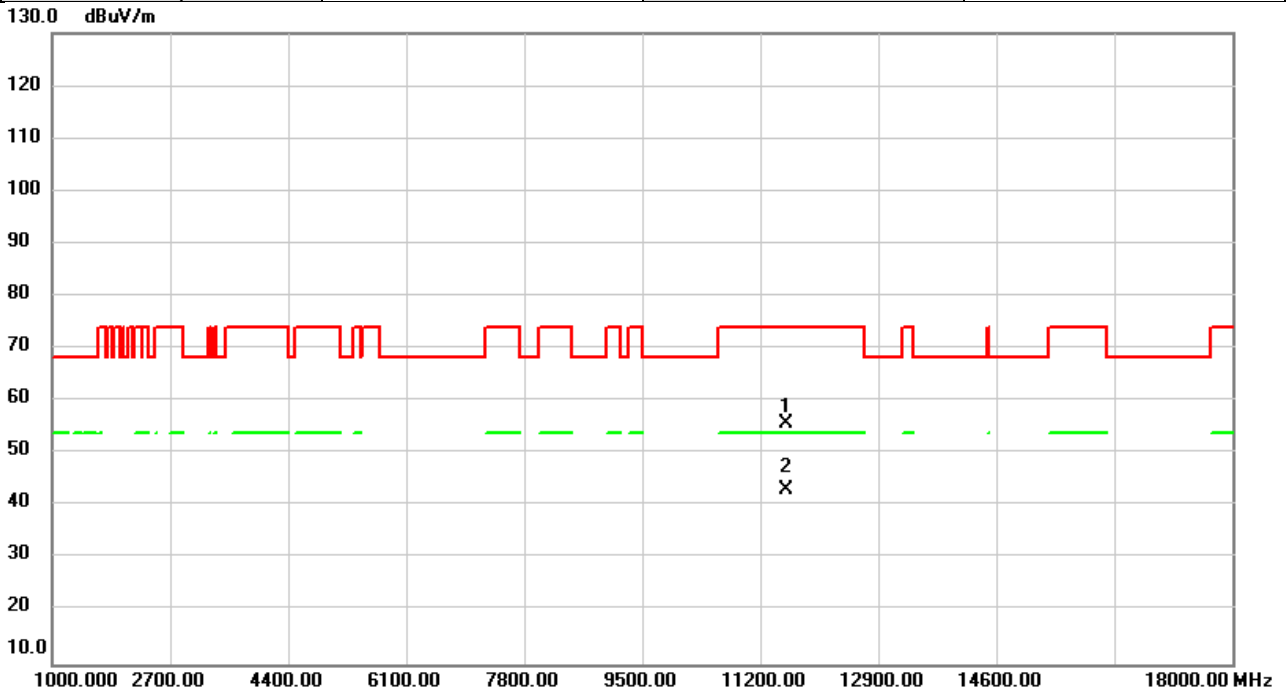

No.	Mk.	Freq.	Reading Level	Correct Factor	Measurement	Limit	Over	Detector	Comment
		MHz	dBuV	dB	dBuV/m	dBuV/m	dB		
1		11570.00	48.10	7.69	55.79	74.00	-18.21	peak	
2	*	11570.00	35.55	7.69	43.24	54.00	-10.76	AVG	

REMARKS:

- (1) Measurement Value = Reading Level + Correct Factor.
- (2) Margin Level = Measurement Value - Limit Value.

Test Mode	IEEE 802.11n (HT20)	Test Date	2024/3/26
Test Frequency	5825MHz	Polarization	Vertical
Temp	24°C	Hum.	64%

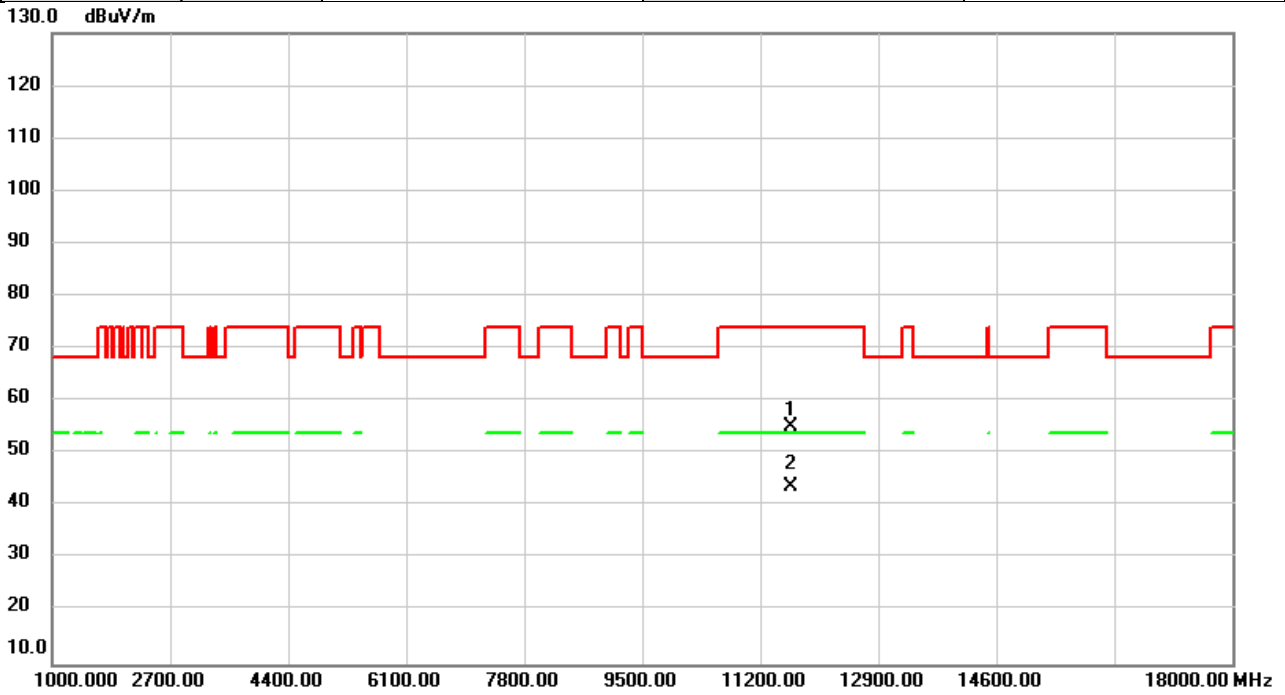

No.	Mk.	Freq. MHz	Reading Level dBuV	Correct Factor dB	Measure- ment dBuV/m	Limit dBuV/m	Over dB	Detector	Comment
1		11650.00	47.46	7.72	55.18	74.00	-18.82	peak	
2	*	11650.00	35.93	7.72	43.65	54.00	-10.35	AVG	

REMARKS:

- (1) Measurement Value = Reading Level + Correct Factor.
- (2) Margin Level = Measurement Value - Limit Value.

Test Mode	IEEE 802.11n (HT20)	Test Date	2024/3/26
Test Frequency	5825MHz	Polarization	Horizontal
Temp	24°C	Hum.	64%

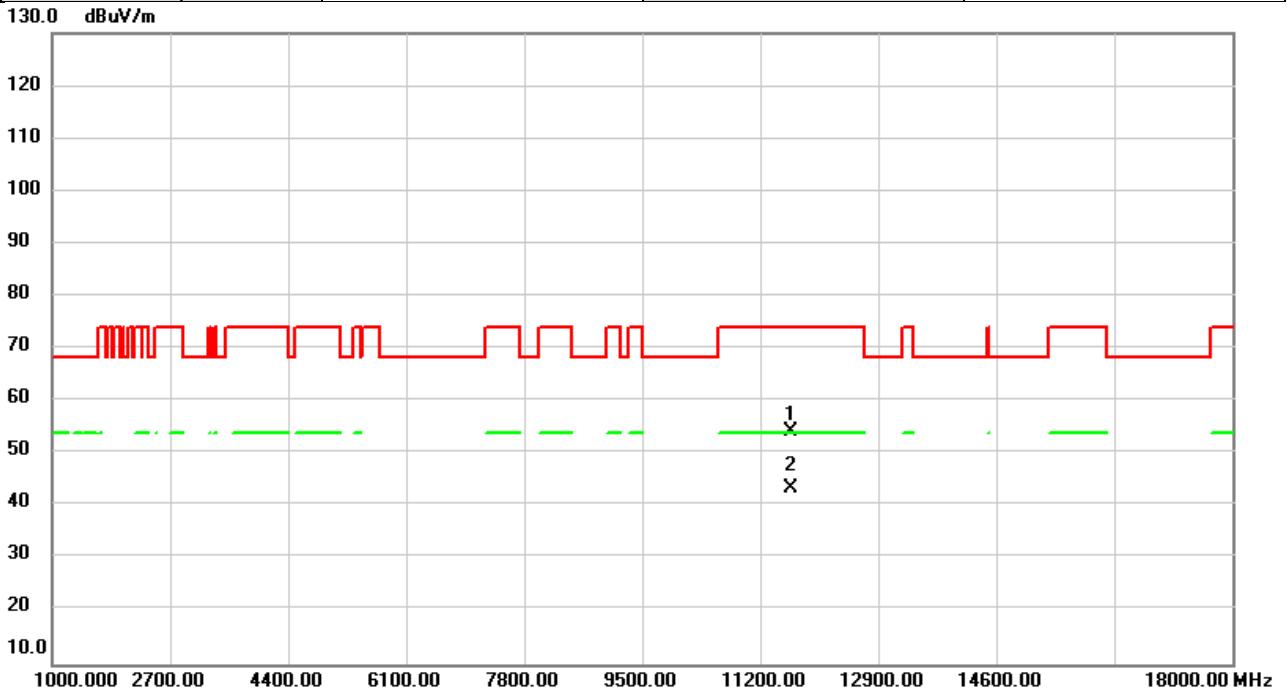

No.	Mk.	Freq.	Reading Level	Correct Factor	Measurement	Limit	Over	Detector	Comment
		MHz	dBuV	dB	dBuV/m	dBuV/m	dB		
1		11650.00	46.66	7.72	54.38	74.00	-19.62	peak	
2	*	11650.00	35.84	7.72	43.56	54.00	-10.44	AVG	

REMARKS:

- (1) Measurement Value = Reading Level + Correct Factor.
- (2) Margin Level = Measurement Value - Limit Value.

Test Mode	IEEE 802.11n (HT40)	Test Date	2024/3/26
Test Frequency	5190MHz	Polarization	Vertical
Temp	24°C	Hum.	64%

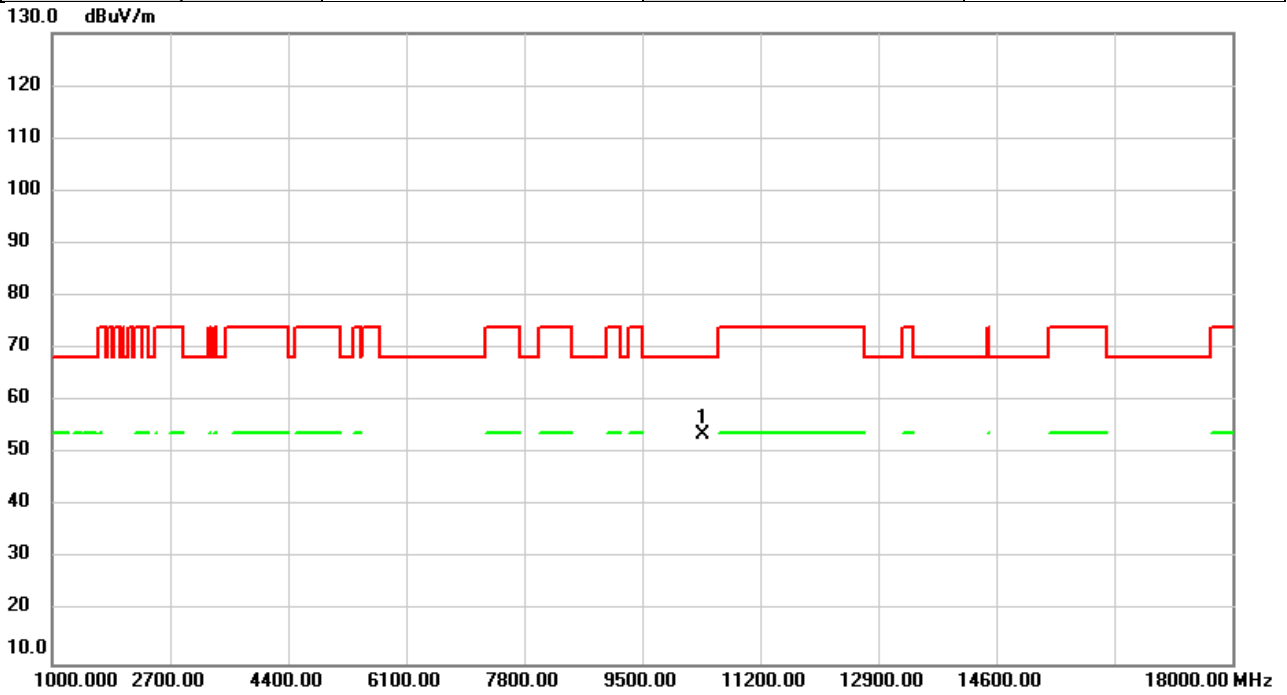

No.	Mk.	Freq.	Reading Level	Correct Factor	Measurement	Limit	Over	Detector	Comment
		MHz	dBuV	dB	dBuV/m	dBuV/m	dB		
1	*	10380.00	47.05	6.68	53.73	68.20	-14.47	peak	

REMARKS:

- (1) Measurement Value = Reading Level + Correct Factor.
- (2) Margin Level = Measurement Value - Limit Value.

Test Mode	IEEE 802.11n (HT40)	Test Date	2024/3/26
Test Frequency	5190MHz	Polarization	Horizontal
Temp	24°C	Hum.	64%

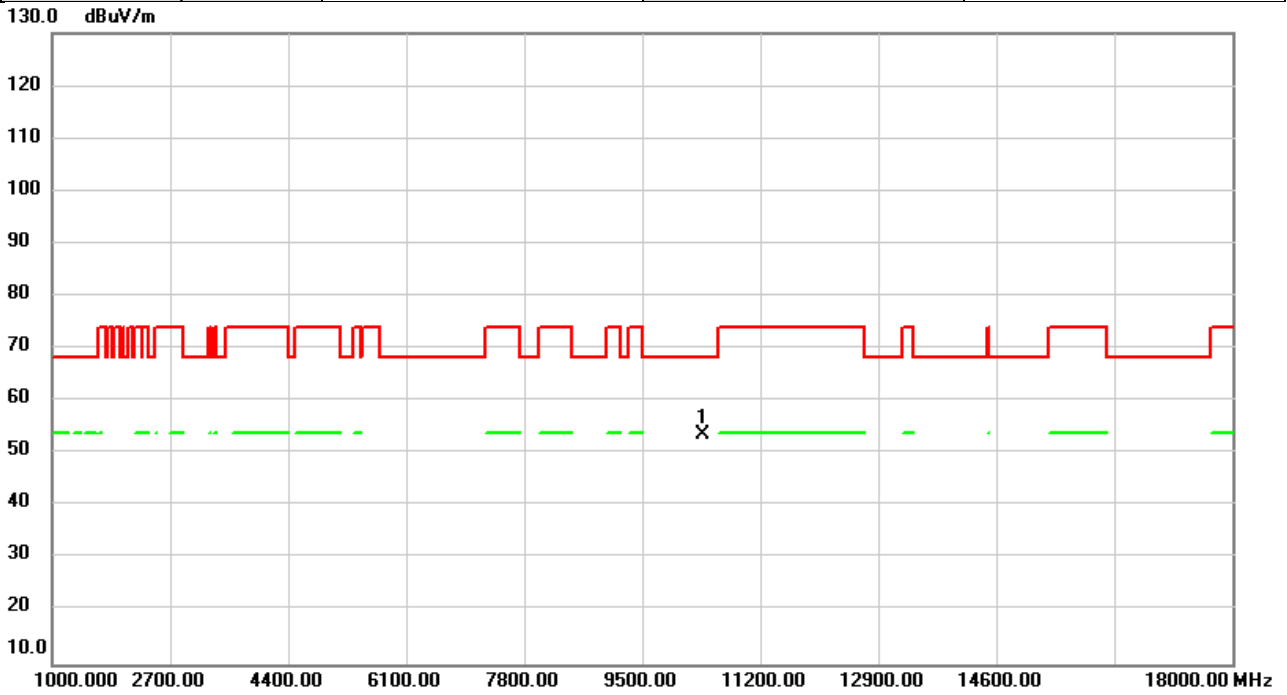

No.	Mk.	Freq.	Reading Level	Correct Factor	Measurement	Limit	Over	Detector	Comment
		MHz	dBuV	dB	dBuV/m	dBuV/m	dB		
1	*	10380.00	46.84	6.68	53.52	68.20	-14.68	peak	

REMARKS:

- (1) Measurement Value = Reading Level + Correct Factor.
- (2) Margin Level = Measurement Value - Limit Value.

Test Mode	IEEE 802.11n (HT40)	Test Date	2024/3/26
Test Frequency	5230MHz	Polarization	Vertical
Temp	24°C	Hum.	64%

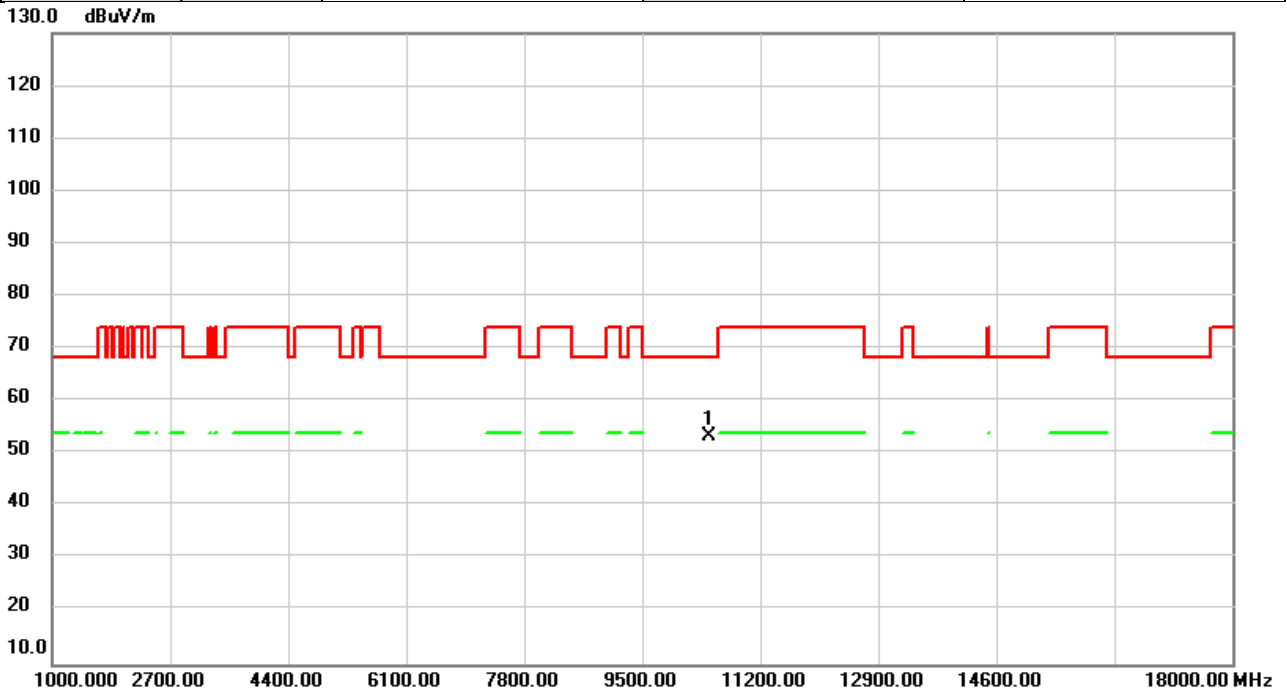

No.	Mk.	Freq.	Reading Level	Correct Factor	Measurement	Limit	Over	Detector	Comment
		MHz	dBuV	dB	dBuV/m	dBuV/m	dB		
1	*	10460.00	46.58	6.70	53.28	68.20	-14.92	peak	

REMARKS:

- (1) Measurement Value = Reading Level + Correct Factor.
- (2) Margin Level = Measurement Value - Limit Value.

Test Mode	IEEE 802.11n (HT40)	Test Date	2024/3/26
Test Frequency	5230MHz	Polarization	Horizontal
Temp	24°C	Hum.	64%

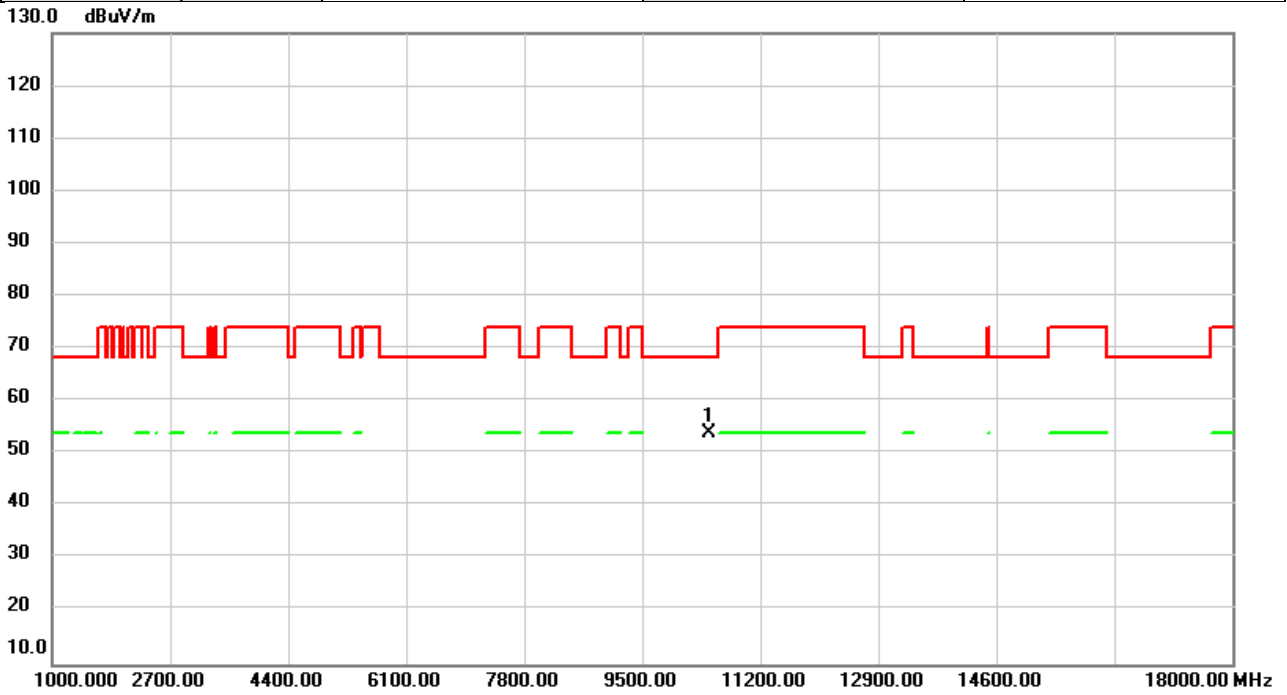

No.	Mk.	Freq.	Reading Level	Correct Factor	Measurement	Limit	Over	Detector	Comment
		MHz	dBuV	dB	dBuV/m	dBuV/m	dB		
1	*	10460.00	47.22	6.70	53.92	68.20	-14.28	peak	

REMARKS:

- (1) Measurement Value = Reading Level + Correct Factor.
- (2) Margin Level = Measurement Value - Limit Value.

Test Mode	IEEE 802.11n (HT40)	Test Date	2024/3/26
Test Frequency	5270MHz	Polarization	Vertical
Temp	24°C	Hum.	64%

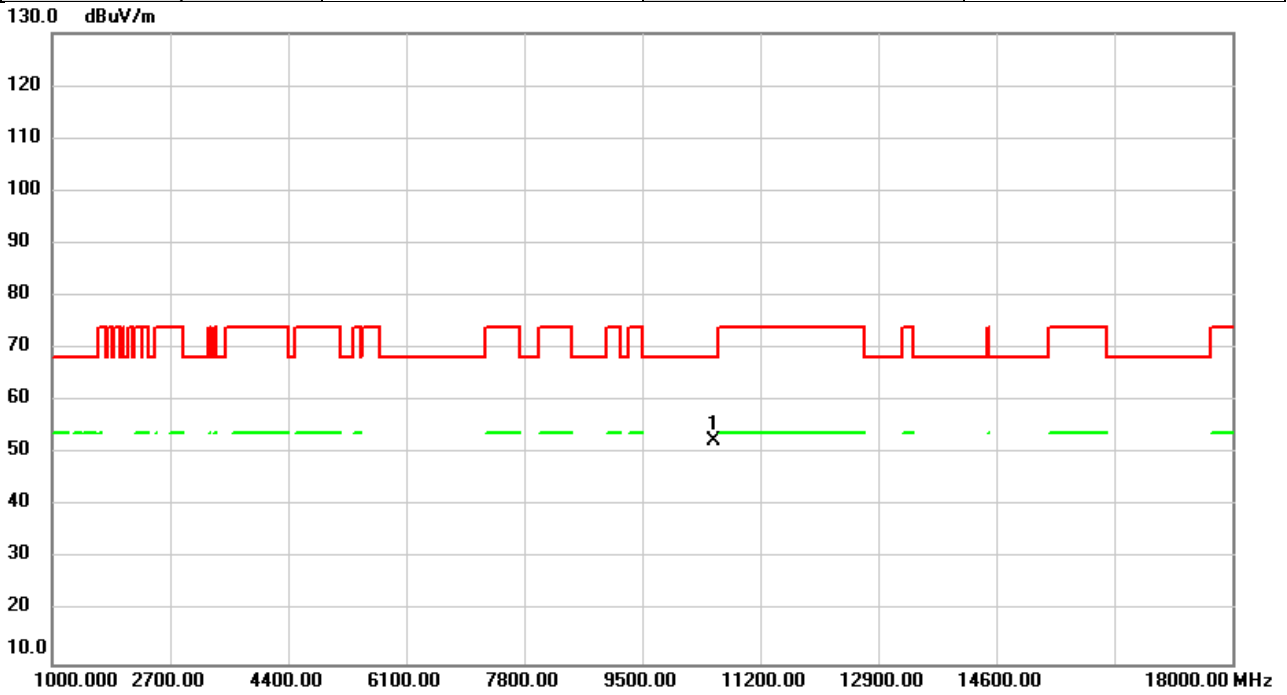

No.	Mk.	Freq.	Reading Level	Correct Factor	Measurement	Limit	Over	Detector	Comment
		MHz	dBuV	dB	dBuV/m	dBuV/m	dB		
1	*	10540.00	45.57	6.75	52.32	68.20	-15.88	peak	

REMARKS:

- (1) Measurement Value = Reading Level + Correct Factor.
- (2) Margin Level = Measurement Value - Limit Value.

Test Mode	IEEE 802.11n (HT40)	Test Date	2024/3/26
Test Frequency	5270MHz	Polarization	Horizontal
Temp	24°C	Hum.	64%

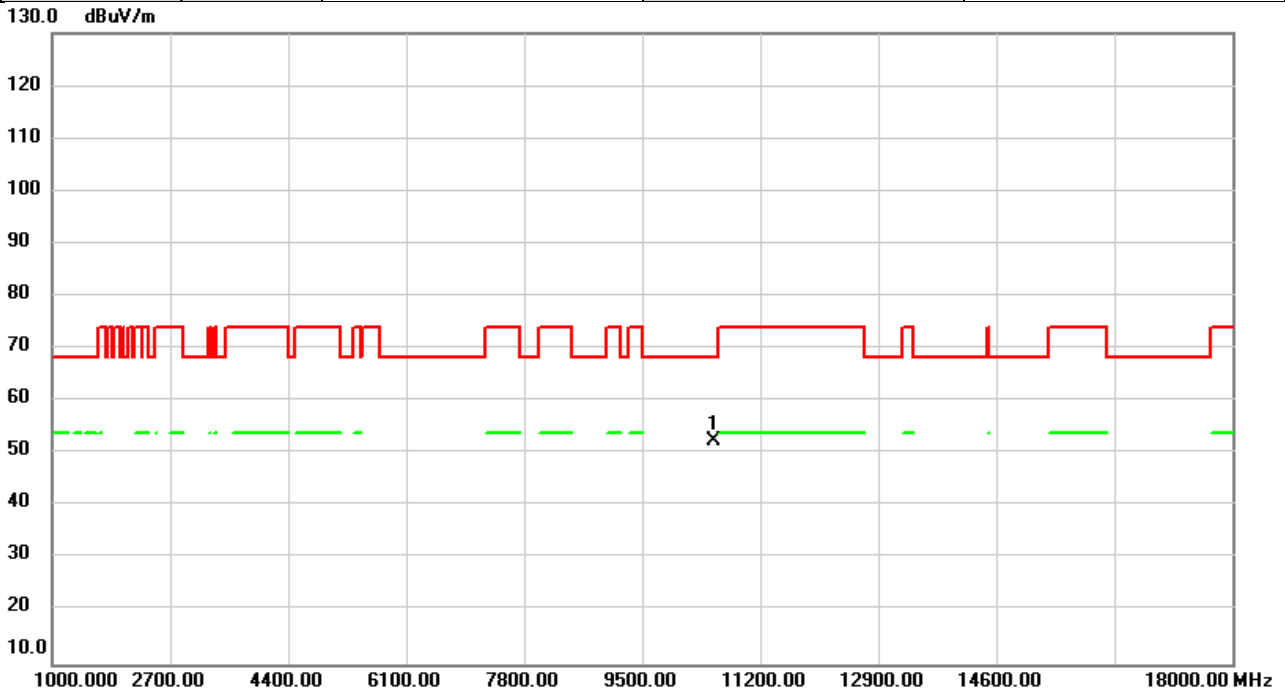

No.	Mk.	Freq.	Reading Level	Correct Factor	Measurement	Limit	Over	Detector	Comment
		MHz	dBuV	dB	dBuV/m	dBuV/m	dB		
1	*	10540.00	45.73	6.75	52.48	68.20	-15.72	peak	

REMARKS:

- (1) Measurement Value = Reading Level + Correct Factor.
- (2) Margin Level = Measurement Value - Limit Value.

Test Mode	IEEE 802.11n (HT40)	Test Date	2024/3/26
Test Frequency	5310MHz	Polarization	Vertical
Temp	24°C	Hum.	64%

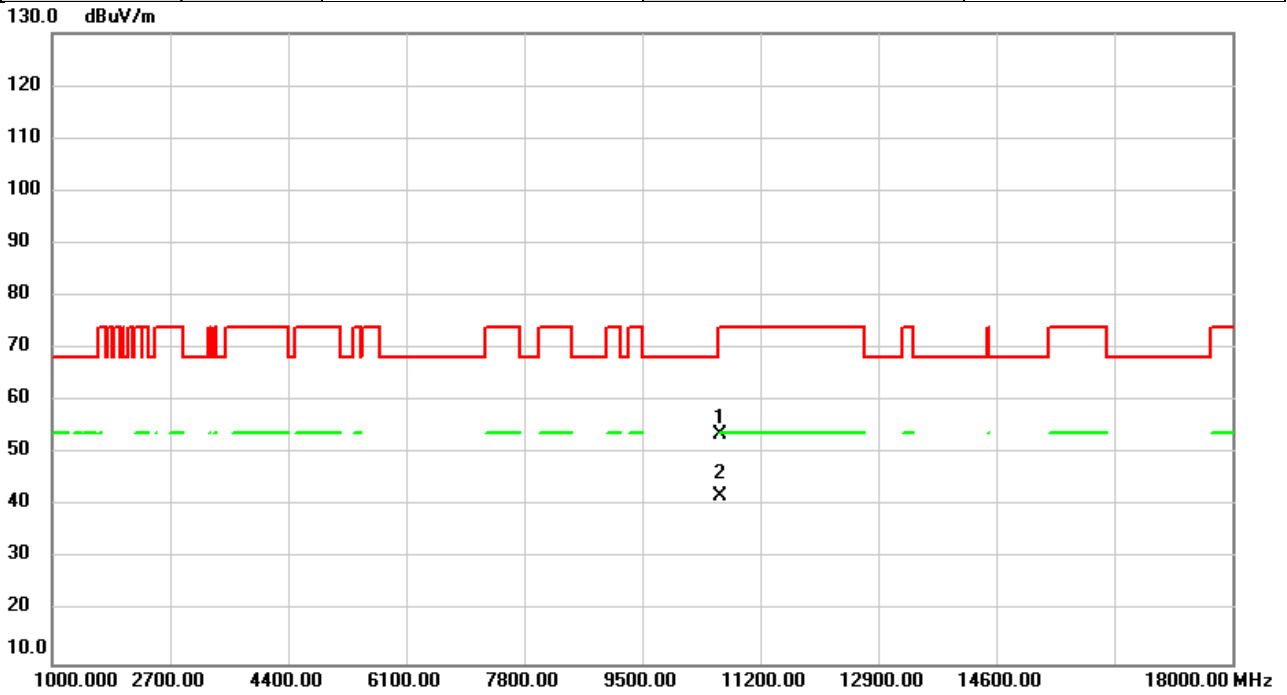

No.	Mk.	Freq. MHz	Reading Level dBuV	Correct Factor dB	Measure- ment dBuV/m	Limit dBuV/m	Over dB	Detector	Comment
1		10620.00	46.69	6.83	53.52	74.00	-20.48	peak	
2	*	10620.00	35.25	6.83	42.08	54.00	-11.92	AVG	

REMARKS:

- (1) Measurement Value = Reading Level + Correct Factor.
- (2) Margin Level = Measurement Value - Limit Value.

Test Mode	IEEE 802.11n (HT40)	Test Date	2024/3/26
Test Frequency	5310MHz	Polarization	Horizontal
Temp	24°C	Hum.	64%

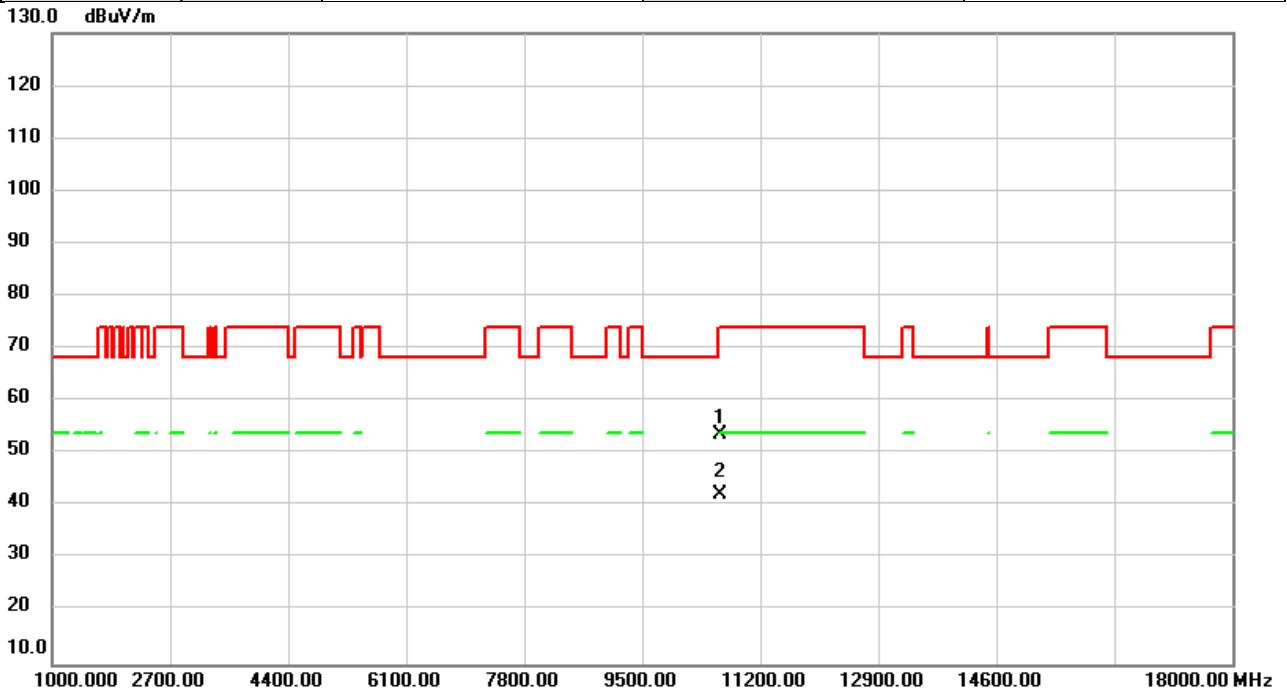

No.	Mk.	Freq. MHz	Reading Level dBuV	Correct Factor dB	Measure- ment dBuV/m	Limit dBuV/m	Over dB	Detector	Comment
1		10620.00	46.90	6.83	53.73	74.00	-20.27	peak	
2	*	10620.00	35.38	6.83	42.21	54.00	-11.79	AVG	

REMARKS:

- (1) Measurement Value = Reading Level + Correct Factor.
- (2) Margin Level = Measurement Value - Limit Value.

Test Mode	IEEE 802.11n (HT40)	Test Date	2024/3/26
Test Frequency	5510MHz	Polarization	Vertical
Temp	24°C	Hum.	64%

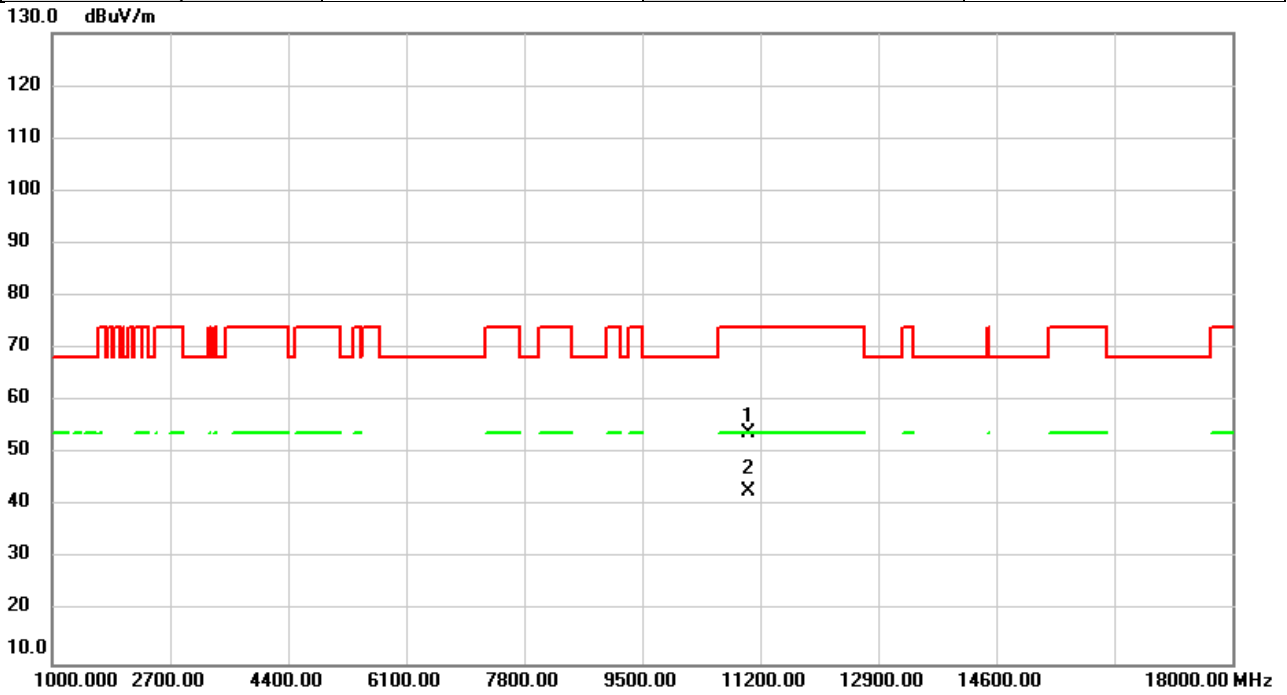

No.	Mk.	Freq.	Reading Level	Correct Factor	Measurement	Limit	Over	Detector	Comment
		MHz	dBuV	dB	dBuV/m	dBuV/m	dB		
1		11020.00	46.68	7.20	53.88	74.00	-20.12	peak	
2	*	11020.00	35.59	7.20	42.79	54.00	-11.21	AVG	

REMARKS:

- (1) Measurement Value = Reading Level + Correct Factor.
- (2) Margin Level = Measurement Value - Limit Value.

Test Mode	IEEE 802.11n (HT40)	Test Date	2024/3/26
Test Frequency	5510MHz	Polarization	Horizontal
Temp	24°C	Hum.	64%

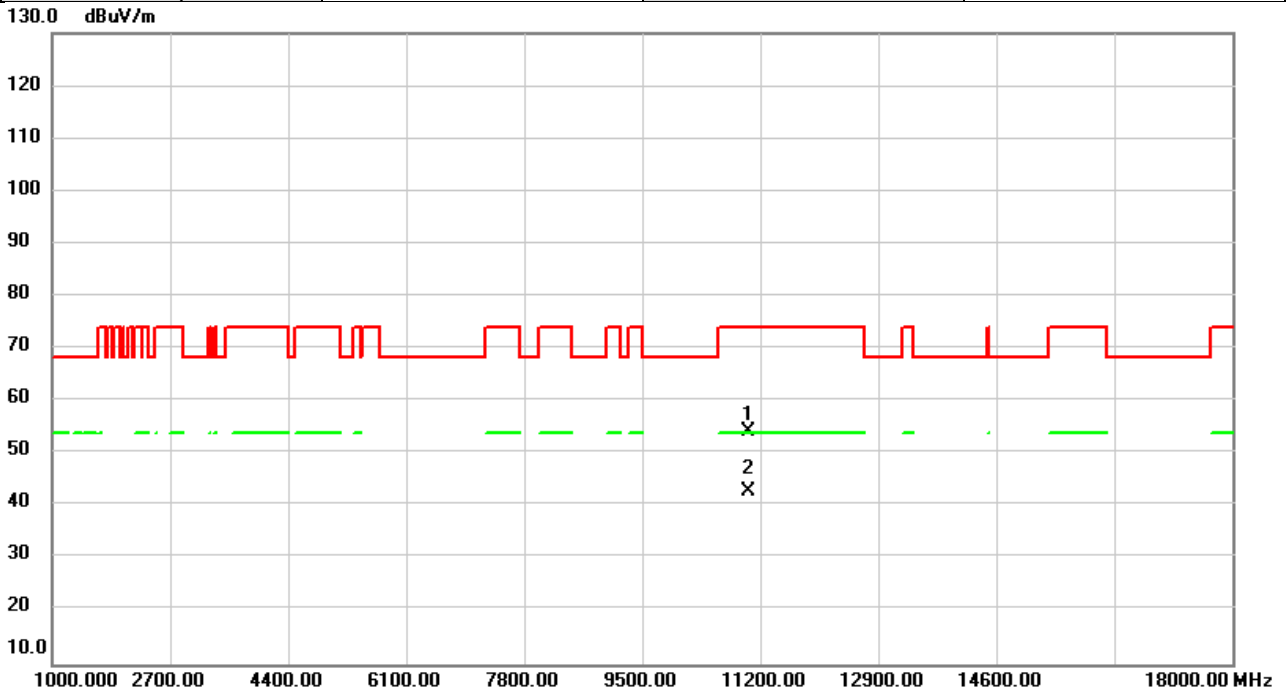

No.	Mk.	Freq. MHz	Reading Level dBuV	Correct Factor dB	Measure- ment dBuV/m	Limit dBuV/m	Over dB	Detector	Comment
1		11020.00	47.19	7.20	54.39	74.00	-19.61	peak	
2	*	11020.00	35.65	7.20	42.85	54.00	-11.15	AVG	

REMARKS:

- (1) Measurement Value = Reading Level + Correct Factor.
- (2) Margin Level = Measurement Value - Limit Value.

Test Mode	IEEE 802.11n (HT40)	Test Date	2024/3/26
Test Frequency	5550MHz	Polarization	Vertical
Temp	24°C	Hum.	64%

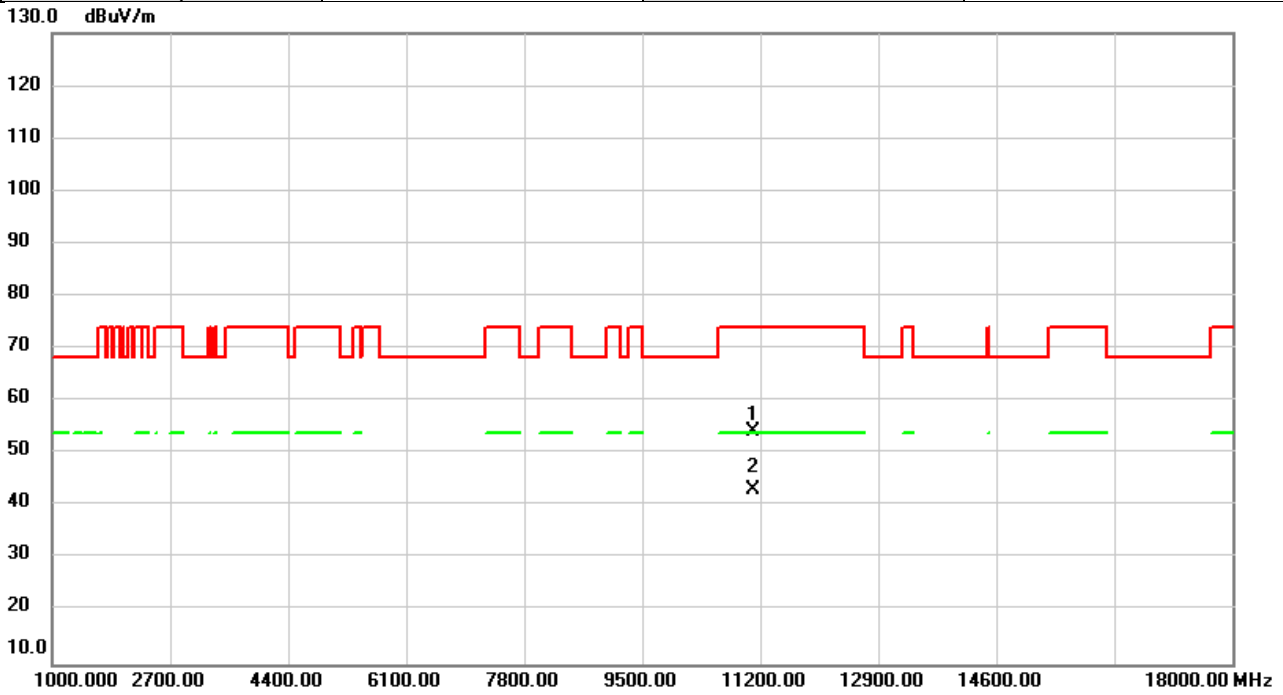

No.	Mk.	Freq.	Reading Level	Correct Factor	Measurement	Limit	Over	Detector	Comment
		MHz	dBuV	dB	dBuV/m	dBuV/m	dB		
1		11100.00	46.90	7.28	54.18	74.00	-19.82	peak	
2	*	11100.00	35.88	7.28	43.16	54.00	-10.84	AVG	

REMARKS:

- (1) Measurement Value = Reading Level + Correct Factor.
- (2) Margin Level = Measurement Value - Limit Value.

Test Mode	IEEE 802.11n (HT40)	Test Date	2024/3/26
Test Frequency	5550MHz	Polarization	Horizontal
Temp	24°C	Hum.	64%

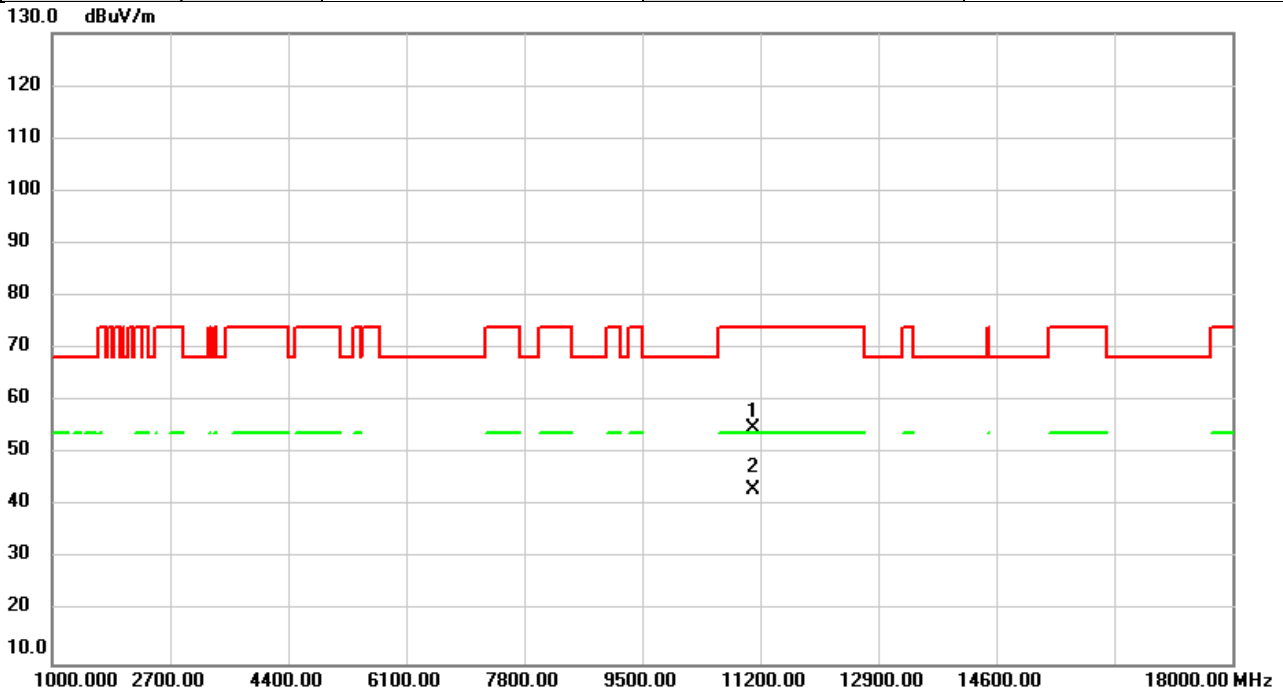

No.	Mk.	Freq.	Reading Level	Correct Factor	Measurement	Limit	Over	Detector	Comment
		MHz	dBuV	dB	dBuV/m	dBuV/m	dB		
1		11100.00	47.61	7.28	54.89	74.00	-19.11	peak	
2	*	11100.00	35.82	7.28	43.10	54.00	-10.90	AVG	

REMARKS:

- (1) Measurement Value = Reading Level + Correct Factor.
- (2) Margin Level = Measurement Value - Limit Value.

Test Mode	IEEE 802.11n (HT40)	Test Date	2024/3/26
Test Frequency	5670MHz	Polarization	Vertical
Temp	24°C	Hum.	64%

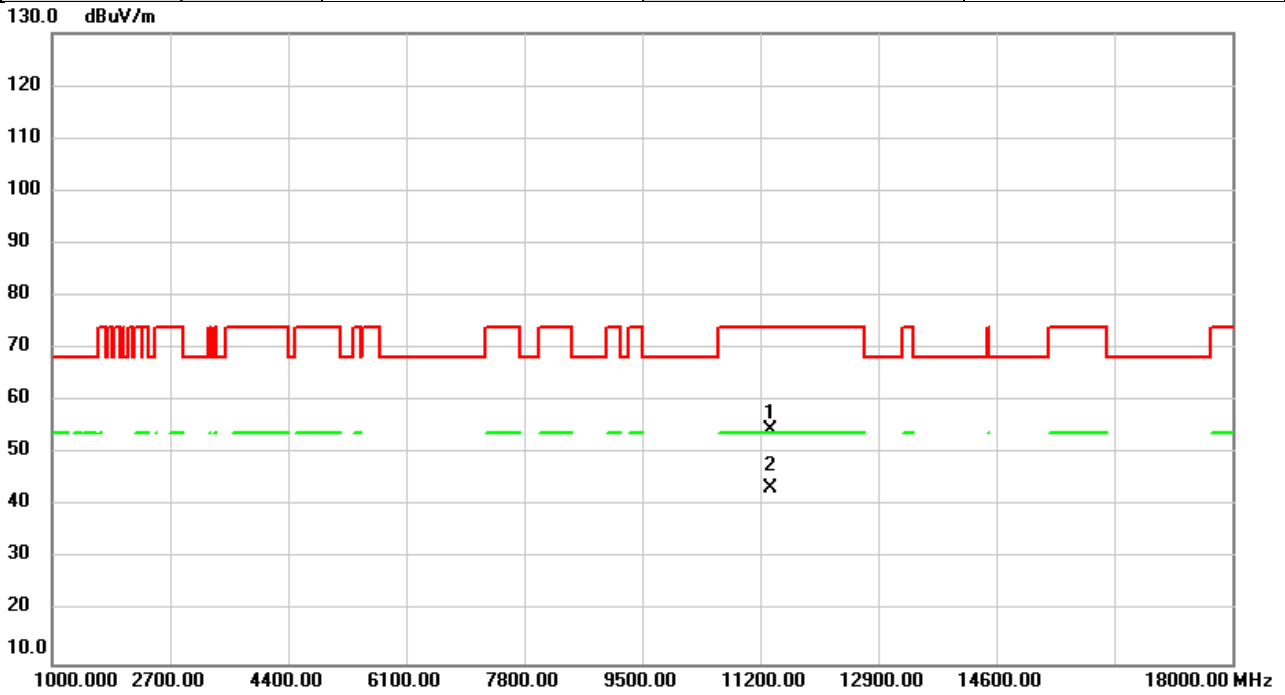

No.	Mk.	Freq.	Reading Level	Correct Factor	Measurement	Limit	Over	Detector	Comment
		MHz	dBuV	dB	dBuV/m	dBuV/m	dB		
1		11340.00	46.93	7.51	54.44	74.00	-19.56	peak	
2	*	11340.00	36.05	7.51	43.56	54.00	-10.44	AVG	

REMARKS:

- (1) Measurement Value = Reading Level + Correct Factor.
- (2) Margin Level = Measurement Value - Limit Value.

Test Mode	IEEE 802.11n (HT40)	Test Date	2024/3/26
Test Frequency	5670MHz	Polarization	Horizontal
Temp	24°C	Hum.	64%

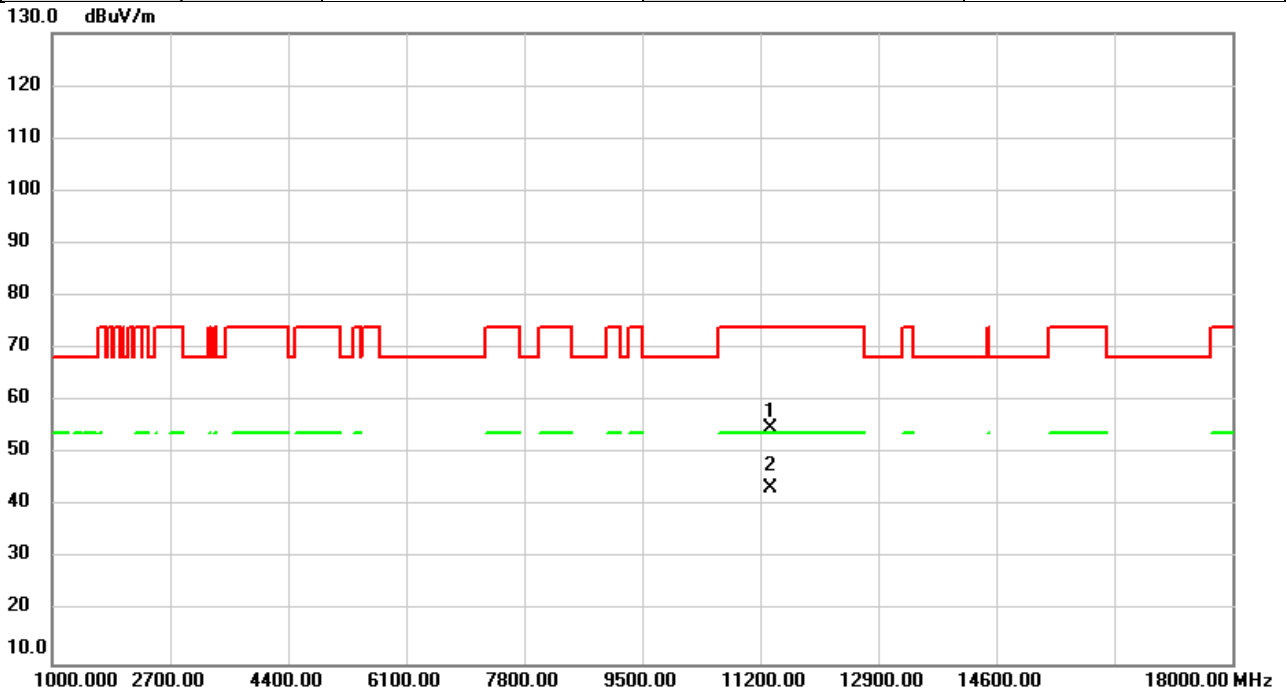

No.	Mk.	Freq.	Reading Level	Correct Factor	Measurement	Limit	Over	Detector	Comment
		MHz	dBuV	dB	dBuV/m	dBuV/m	dB		
1		11340.00	47.23	7.51	54.74	74.00	-19.26	peak	
2	*	11340.00	36.06	7.51	43.57	54.00	-10.43	AVG	

REMARKS:

- (1) Measurement Value = Reading Level + Correct Factor.
- (2) Margin Level = Measurement Value - Limit Value.

Test Mode	IEEE 802.11n (HT40)	Test Date	2024/3/26
Test Frequency	5755MHz	Polarization	Vertical
Temp	24°C	Hum.	64%

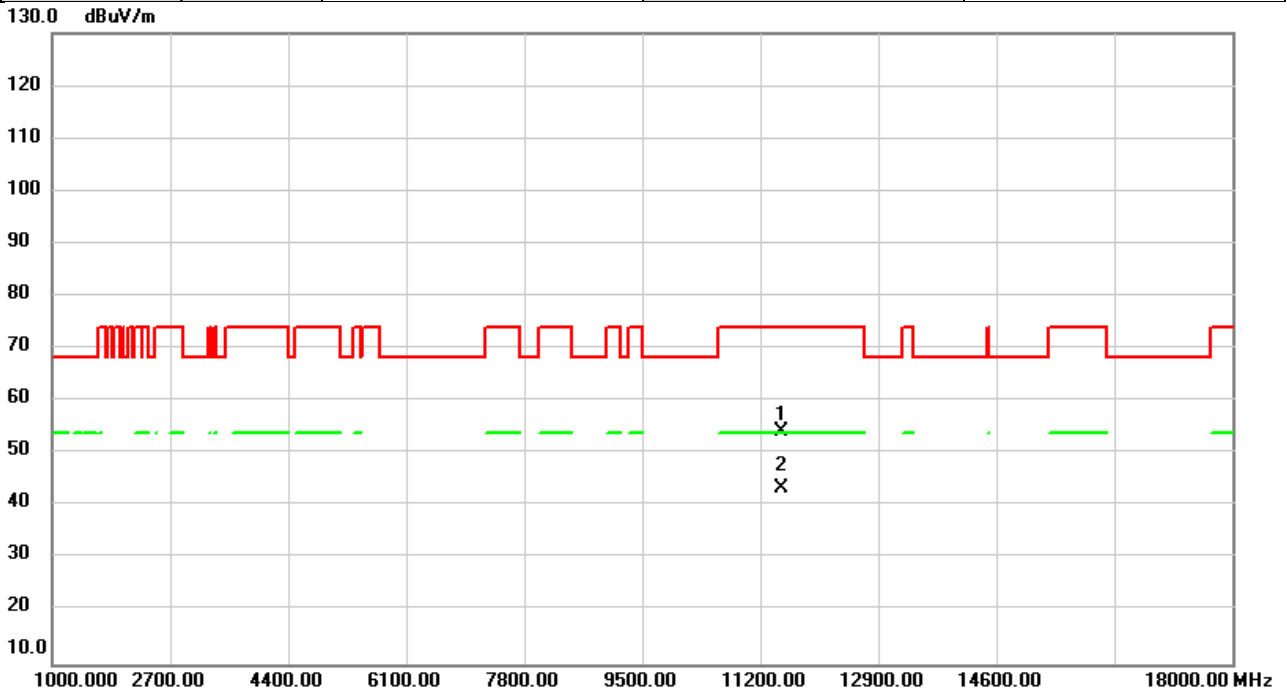

No.	Mk.	Freq. MHz	Reading Level dBuV	Correct Factor dB	Measure- ment dBuV/m	Limit dBuV/m	Over dB	Detector	Comment
1		11510.00	46.70	7.67	54.37	74.00	-19.63	peak	
2	*	11510.00	35.78	7.67	43.45	54.00	-10.55	AVG	

REMARKS:

- (1) Measurement Value = Reading Level + Correct Factor.
- (2) Margin Level = Measurement Value - Limit Value.

Test Mode	IEEE 802.11n (HT40)	Test Date	2024/3/26
Test Frequency	5755MHz	Polarization	Horizontal
Temp	24°C	Hum.	64%

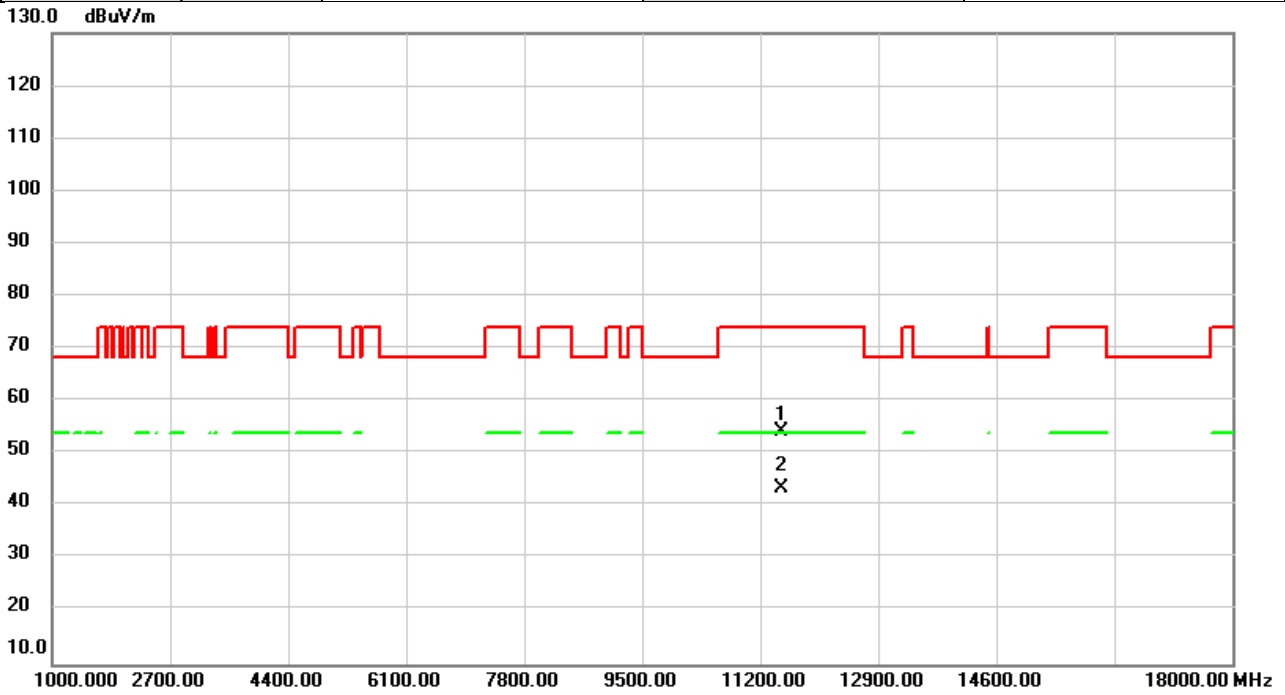

No.	Mk.	Freq. MHz	Reading Level dBuV	Correct Factor dB	Measure- ment dBuV/m	Limit dBuV/m	Over dB	Detector	Comment
1		11510.00	46.73	7.67	54.40	74.00	-19.60	peak	
2	*	11510.00	35.82	7.67	43.49	54.00	-10.51	AVG	

REMARKS:

- (1) Measurement Value = Reading Level + Correct Factor.
- (2) Margin Level = Measurement Value - Limit Value.

Test Mode	IEEE 802.11n (HT40)	Test Date	2024/3/26
Test Frequency	5795MHz	Polarization	Vertical
Temp	24°C	Hum.	64%

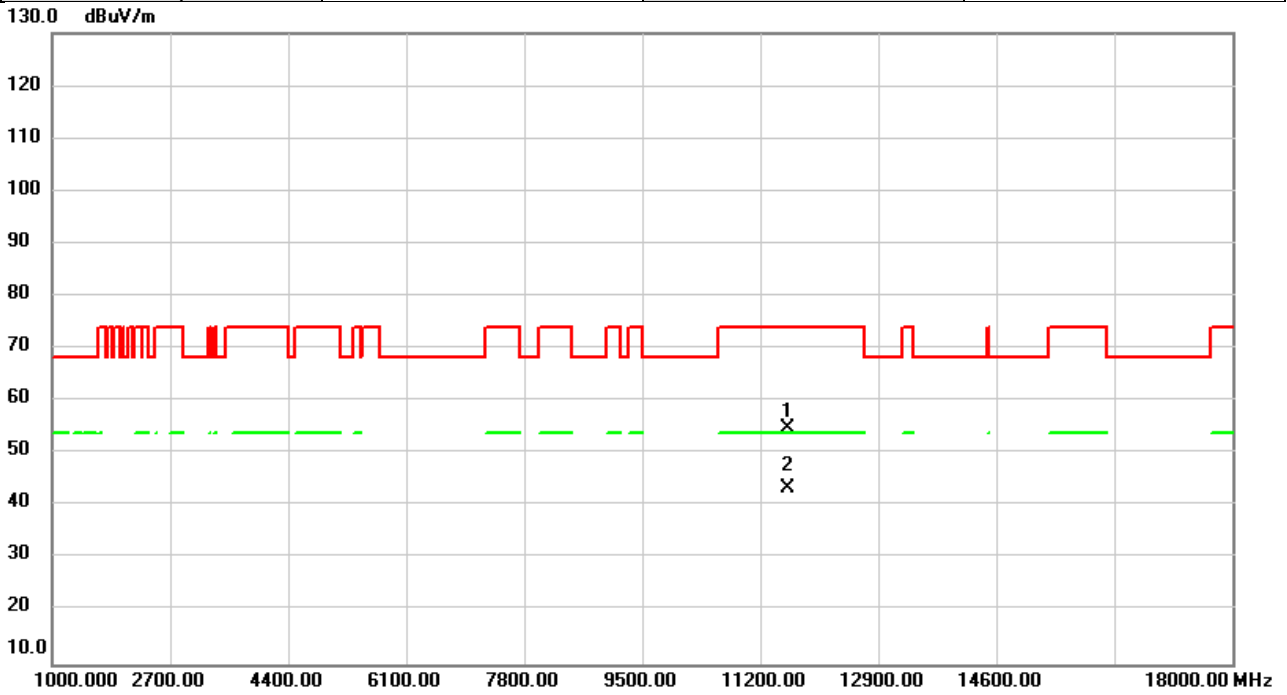

No.	Mk.	Freq.	Reading Level	Correct Factor	Measurement	Limit	Over	Detector	Comment
		MHz	dBuV	dB	dBuV/m	dBuV/m	dB		
1		11590.00	47.15	7.71	54.86	74.00	-19.14	peak	
2	*	11590.00	35.87	7.71	43.58	54.00	-10.42	AVG	

REMARKS:

- (1) Measurement Value = Reading Level + Correct Factor.
- (2) Margin Level = Measurement Value - Limit Value.

Test Mode	IEEE 802.11n (HT40)	Test Date	2024/3/26
Test Frequency	5795MHz	Polarization	Horizontal
Temp	24°C	Hum.	64%

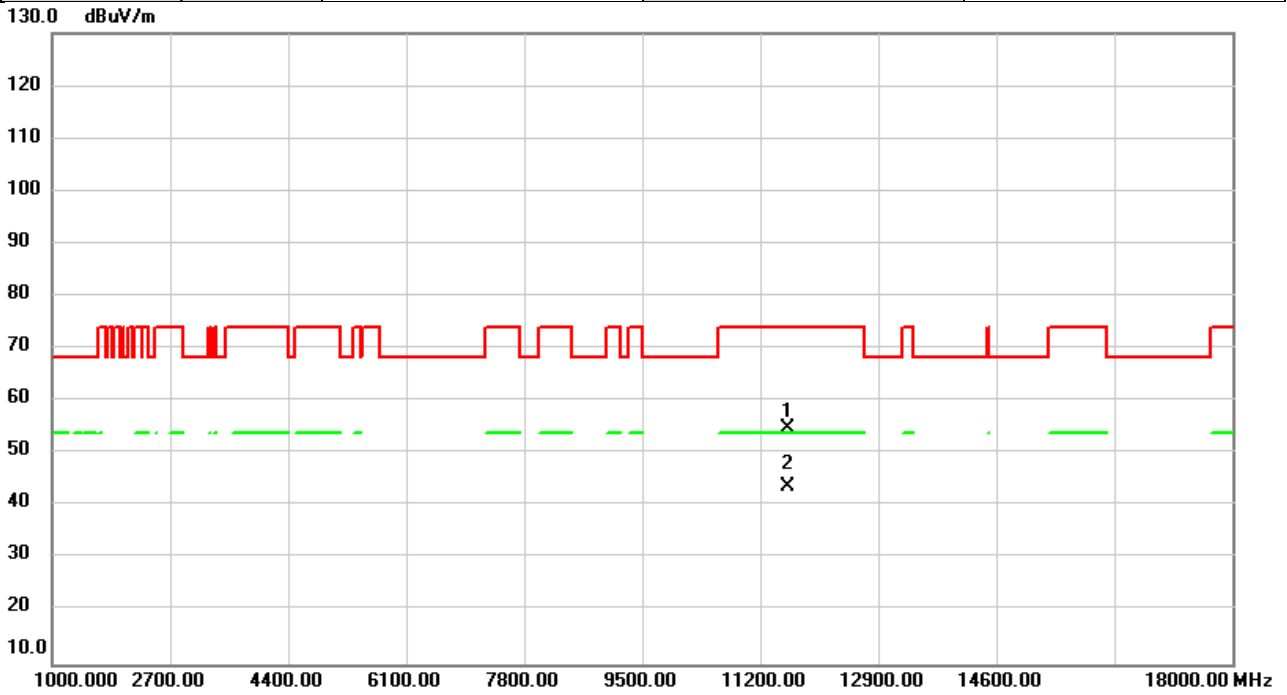

No.	Mk.	Freq.	Reading Level	Correct Factor	Measurement	Limit	Over	Detector	Comment
		MHz	dBuV	dB	dBuV/m	dBuV/m	dB		
1		11590.00	47.21	7.71	54.92	74.00	-19.08	peak	
2	*	11590.00	36.13	7.71	43.84	54.00	-10.16	AVG	

REMARKS:

- (1) Measurement Value = Reading Level + Correct Factor.
- (2) Margin Level = Measurement Value - Limit Value.

Test Mode	IEEE 802.11ac (VHT80)	Test Date	2024/3/26
Test Frequency	5210MHz	Polarization	Vertical
Temp	24°C	Hum.	64%

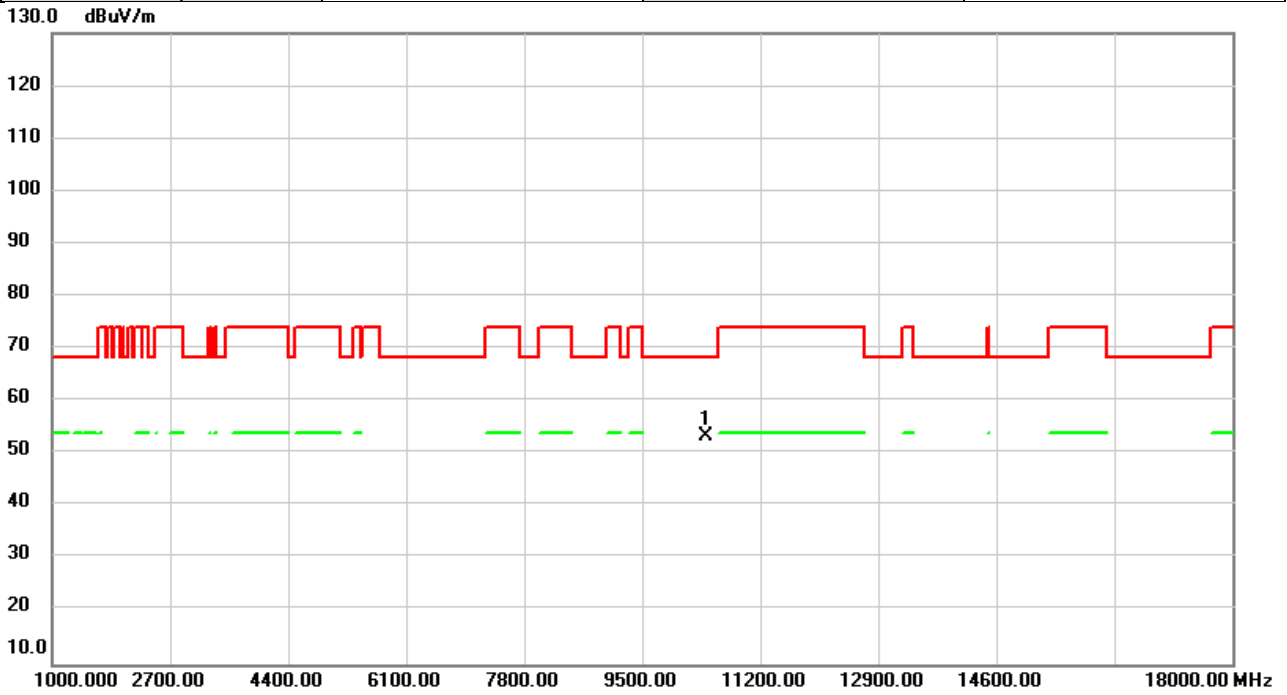

No.	Mk.	Freq.	Reading Level	Correct Factor	Measurement	Limit	Over	Detector	Comment
		MHz	dBuV	dB	dBuV/m	dBuV/m	dB		
1	*	10420.00	46.75	6.68	53.43	68.20	-14.77	peak	

REMARKS:

- (1) Measurement Value = Reading Level + Correct Factor.
- (2) Margin Level = Measurement Value - Limit Value.

Test Mode	IEEE 802.11ac (VHT80)	Test Date	2024/3/26
Test Frequency	5210MHz	Polarization	Horizontal
Temp	24°C	Hum.	64%

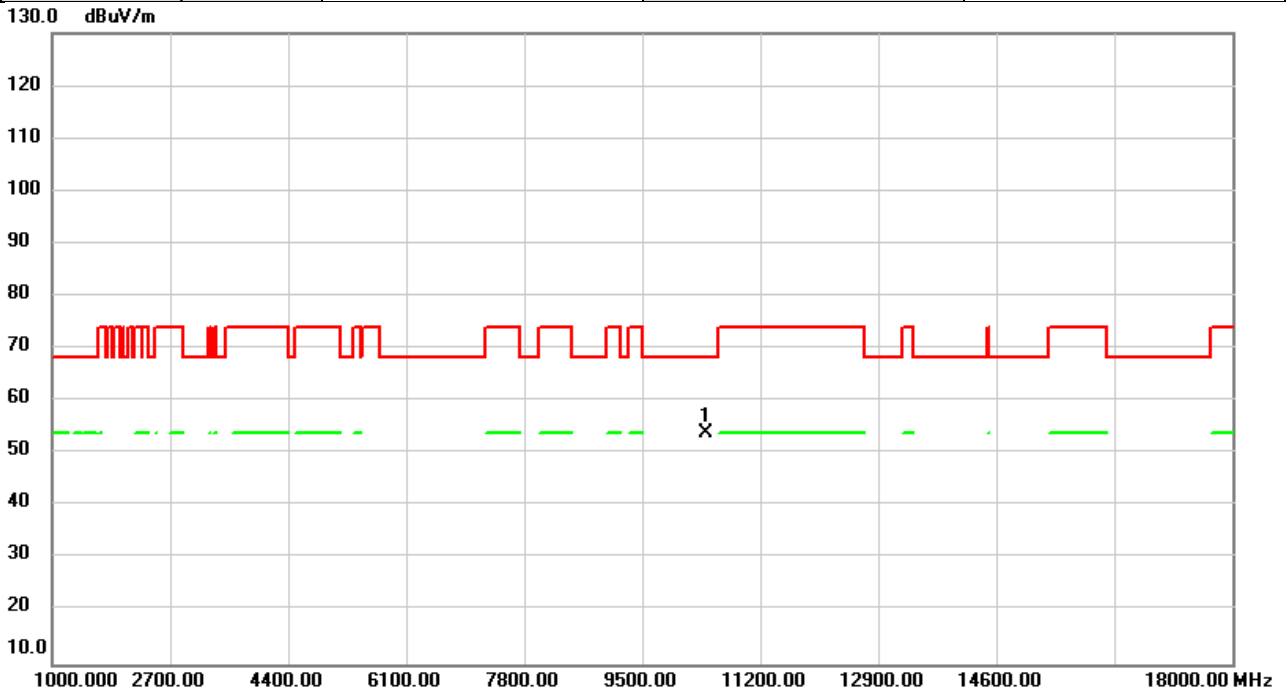

No.	Mk.	Freq.	Reading Level	Correct Factor	Measurement	Limit	Over	Detector	Comment
		MHz	dBuV	dB	dBuV/m	dBuV/m	dB		
1	*	10420.00	47.24	6.68	53.92	68.20	-14.28	peak	

REMARKS:

- (1) Measurement Value = Reading Level + Correct Factor.
- (2) Margin Level = Measurement Value - Limit Value.

Test Mode	IEEE 802.11ac (VHT80)	Test Date	2024/3/26
Test Frequency	5290MHz	Polarization	Vertical
Temp	24°C	Hum.	64%

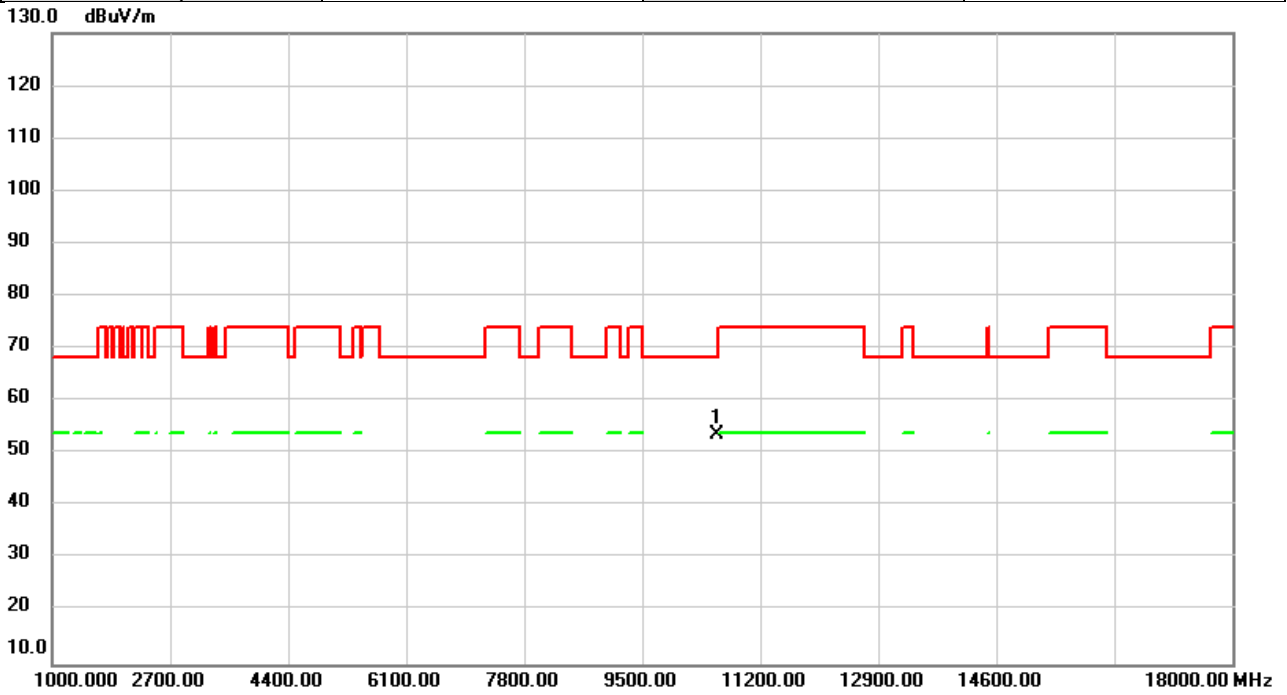

No.	Mk.	Freq.	Reading Level	Correct Factor	Measurement	Limit	Over	Detector	Comment
		MHz	dBuV	dB	dBuV/m	dBuV/m	dB		
1	*	10580.00	46.85	6.78	53.63	68.20	-14.57	peak	

REMARKS:

- (1) Measurement Value = Reading Level + Correct Factor.
- (2) Margin Level = Measurement Value - Limit Value.

Test Mode	IEEE 802.11ac (VHT80)	Test Date	2024/3/26
Test Frequency	5290MHz	Polarization	Horizontal
Temp	24°C	Hum.	64%

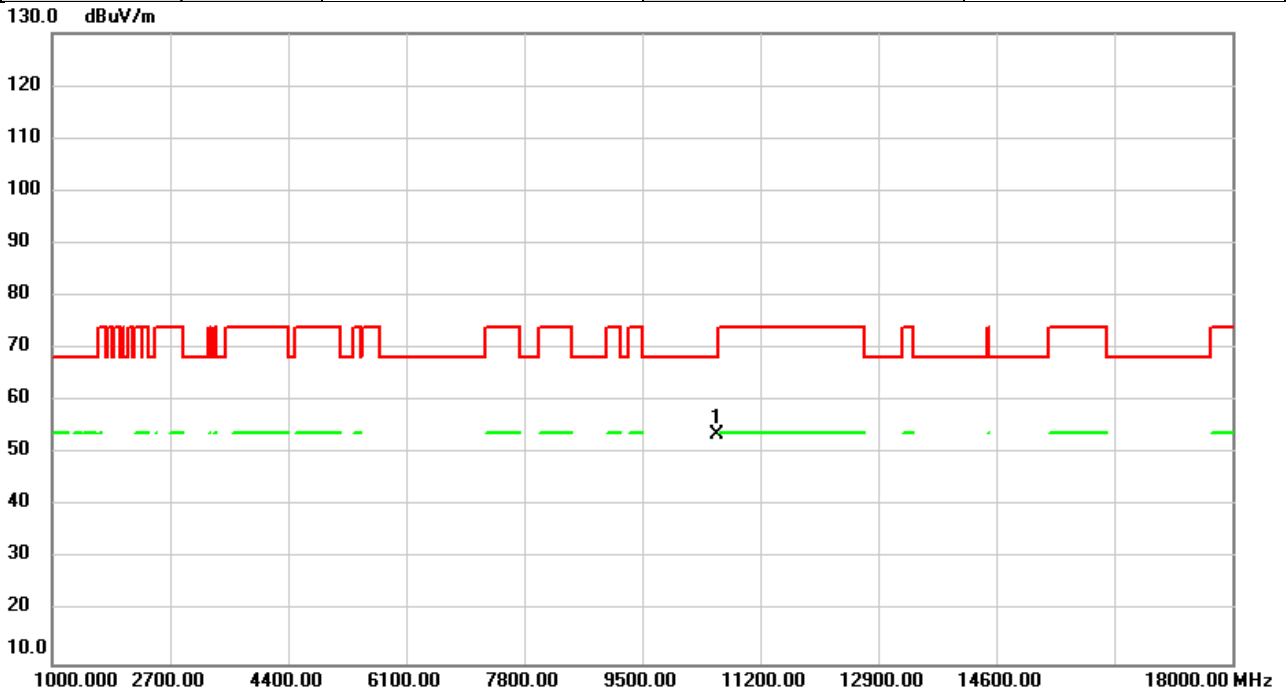

No.	Mk.	Freq.	Reading Level	Correct Factor	Measurement	Limit	Over	Detector	Comment
		MHz	dBuV	dB	dBuV/m	dBuV/m	dB		
1	*	10580.00	46.86	6.78	53.64	68.20	-14.56	peak	

REMARKS:

- (1) Measurement Value = Reading Level + Correct Factor.
- (2) Margin Level = Measurement Value - Limit Value.

Test Mode	IEEE 802.11ac (VHT80)	Test Date	2024/3/26
Test Frequency	5530MHz	Polarization	Vertical
Temp	24°C	Hum.	64%

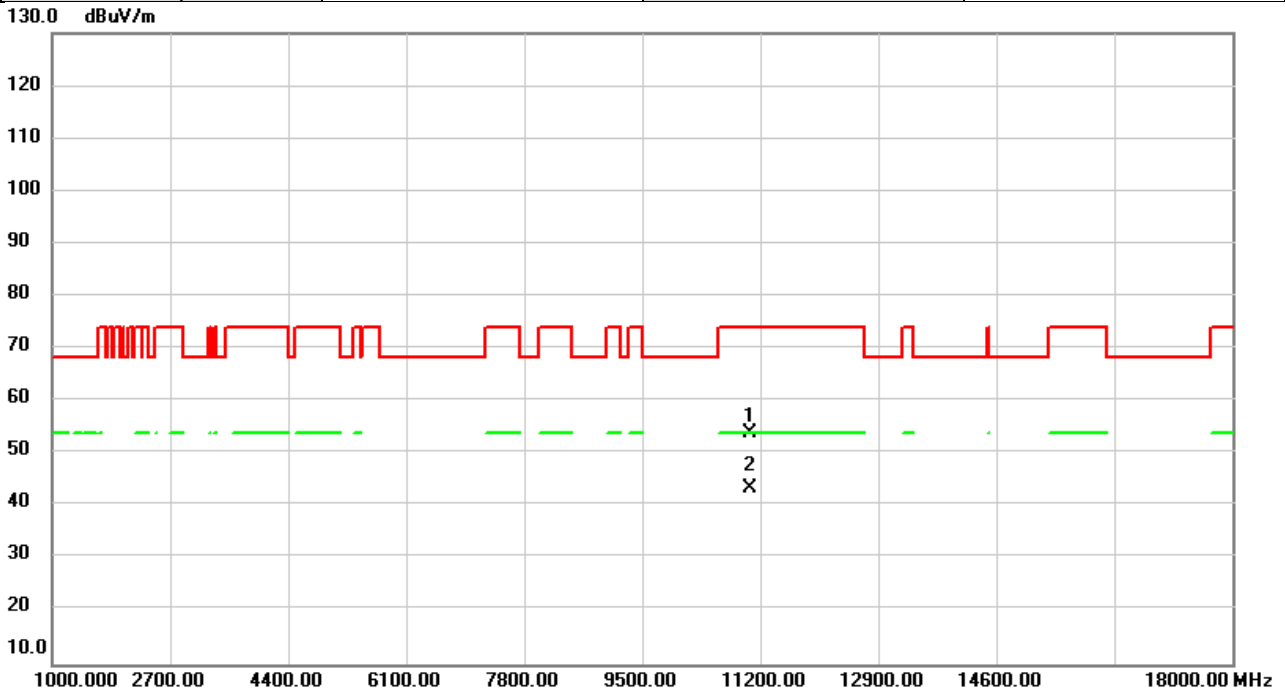

No.	Mk.	Freq. MHz	Reading Level dBuV	Correct Factor dB	Measure- ment dBuV/m	Limit dBuV/m	Over dB	Detector	Comment
1		11060.00	46.76	7.25	54.01	74.00	-19.99	peak	
2	*	11060.00	36.32	7.25	43.57	54.00	-10.43	AVG	

REMARKS:

- (1) Measurement Value = Reading Level + Correct Factor.
- (2) Margin Level = Measurement Value - Limit Value.

Test Mode	IEEE 802.11ac (VHT80)	Test Date	2024/3/26
Test Frequency	5530MHz	Polarization	Horizontal
Temp	24°C	Hum.	64%

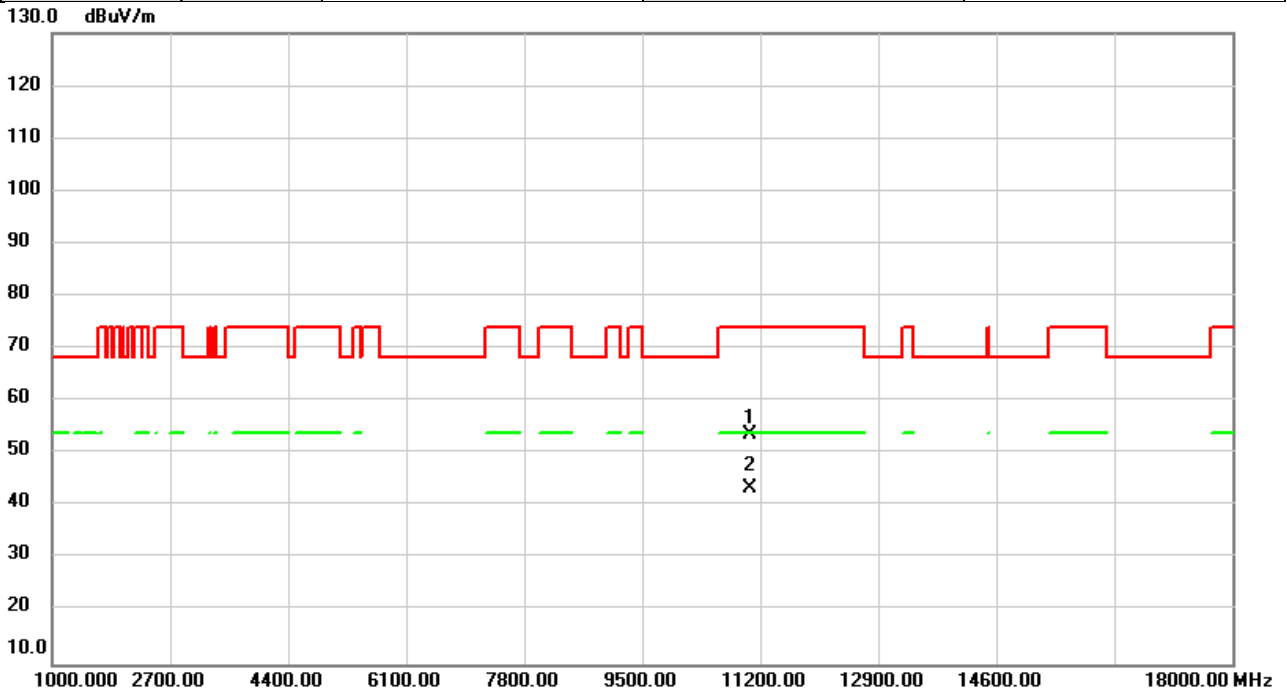

No.	Mk.	Freq.	Reading Level	Correct Factor	Measurement	Limit	Over	Detector	Comment
		MHz	dBuV	dB	dBuV/m	dBuV/m	dB		
1		11060.00	46.46	7.25	53.71	74.00	-20.29	peak	
2	*	11060.00	36.23	7.25	43.48	54.00	-10.52	AVG	

REMARKS:

- (1) Measurement Value = Reading Level + Correct Factor.
- (2) Margin Level = Measurement Value - Limit Value.

Test Mode	IEEE 802.11ac (VHT80)	Test Date	2024/3/26
Test Frequency	5610MHz	Polarization	Vertical
Temp	24°C	Hum.	64%

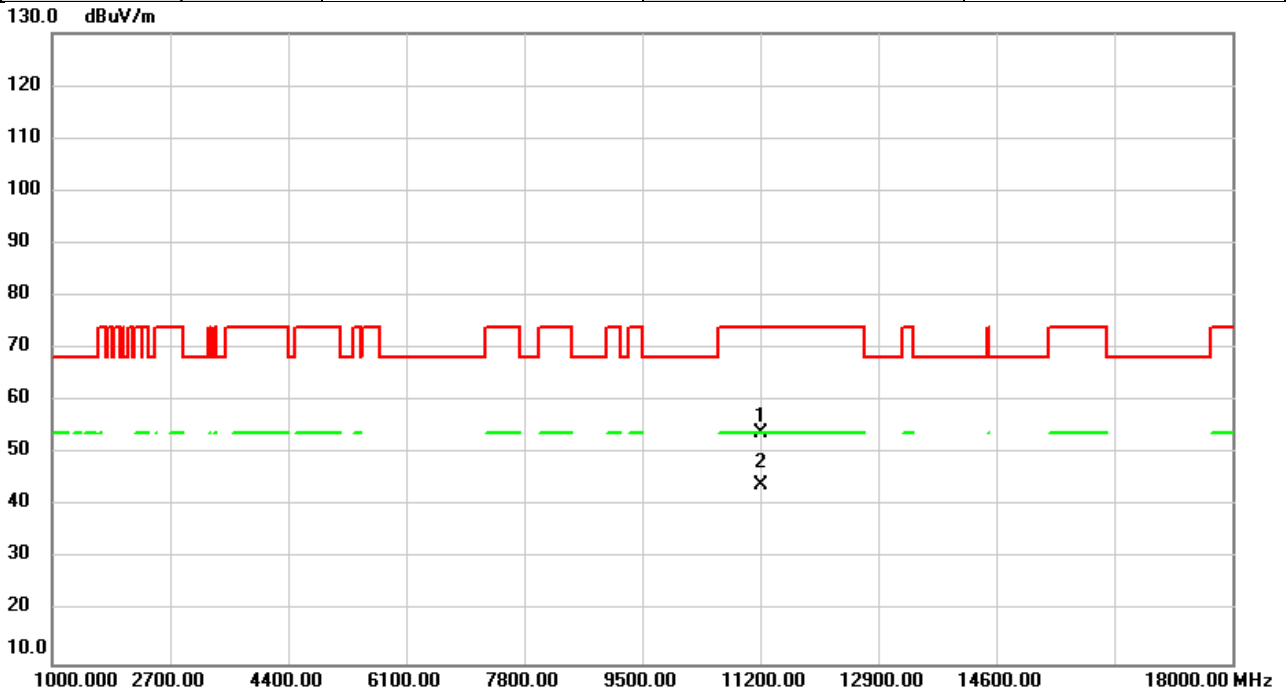

No.	Mk.	Freq.	Reading Level	Correct Factor	Measurement	Limit	Over	Detector	Comment
		MHz	dBuV	dB	dBuV/m	dBuV/m	dB		
1		11220.00	46.54	7.40	53.94	74.00	-20.06	peak	
2	*	11220.00	36.59	7.40	43.99	54.00	-10.01	AVG	

REMARKS:

- (1) Measurement Value = Reading Level + Correct Factor.
- (2) Margin Level = Measurement Value - Limit Value.

Test Mode	IEEE 802.11ac (VHT80)	Test Date	2024/3/26
Test Frequency	5610MHz	Polarization	Horizontal
Temp	24°C	Hum.	64%

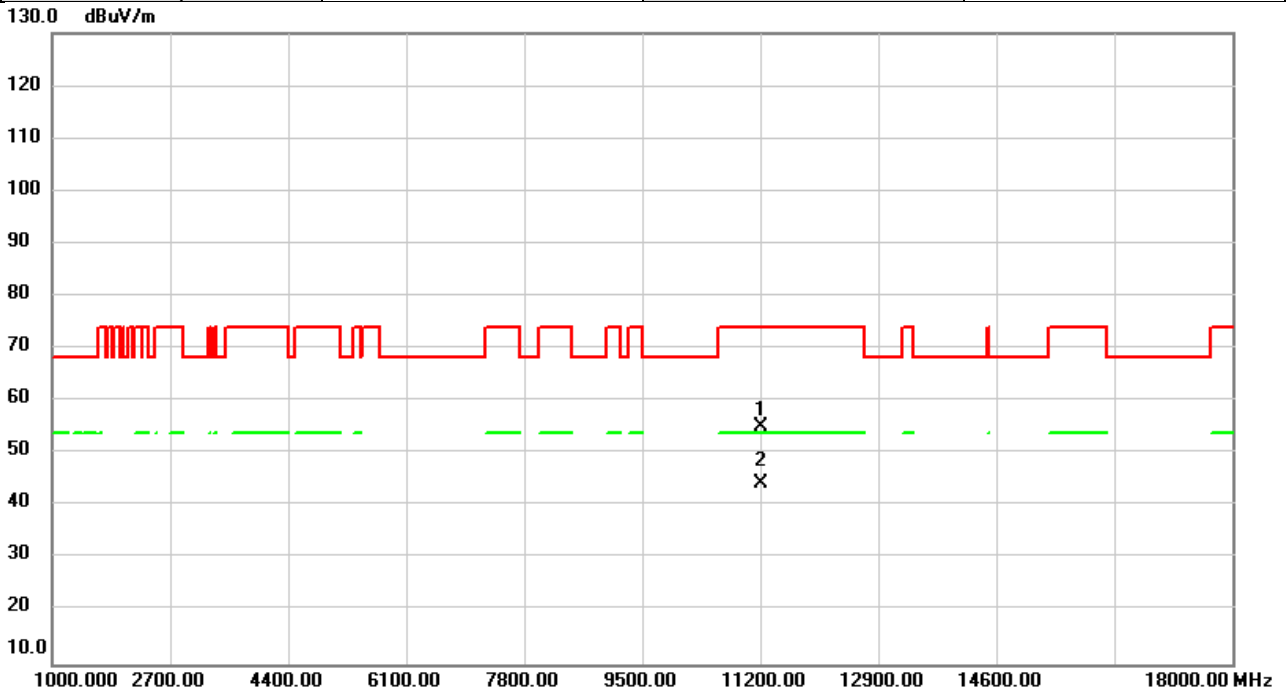

No.	Mk.	Freq.	Reading Level	Correct Factor	Measurement	Limit	Over	Detector	Comment
		MHz	dBuV	dB	dBuV/m	dBuV/m	dB		
1		11220.00	47.76	7.40	55.16	74.00	-18.84	peak	
2	*	11220.00	36.87	7.40	44.27	54.00	-9.73	AVG	

REMARKS:

- (1) Measurement Value = Reading Level + Correct Factor.
- (2) Margin Level = Measurement Value - Limit Value.

Test Mode	IEEE 802.11ac (VHT80)	Test Date	2024/3/26
Test Frequency	5775MHz	Polarization	Vertical
Temp	24°C	Hum.	64%

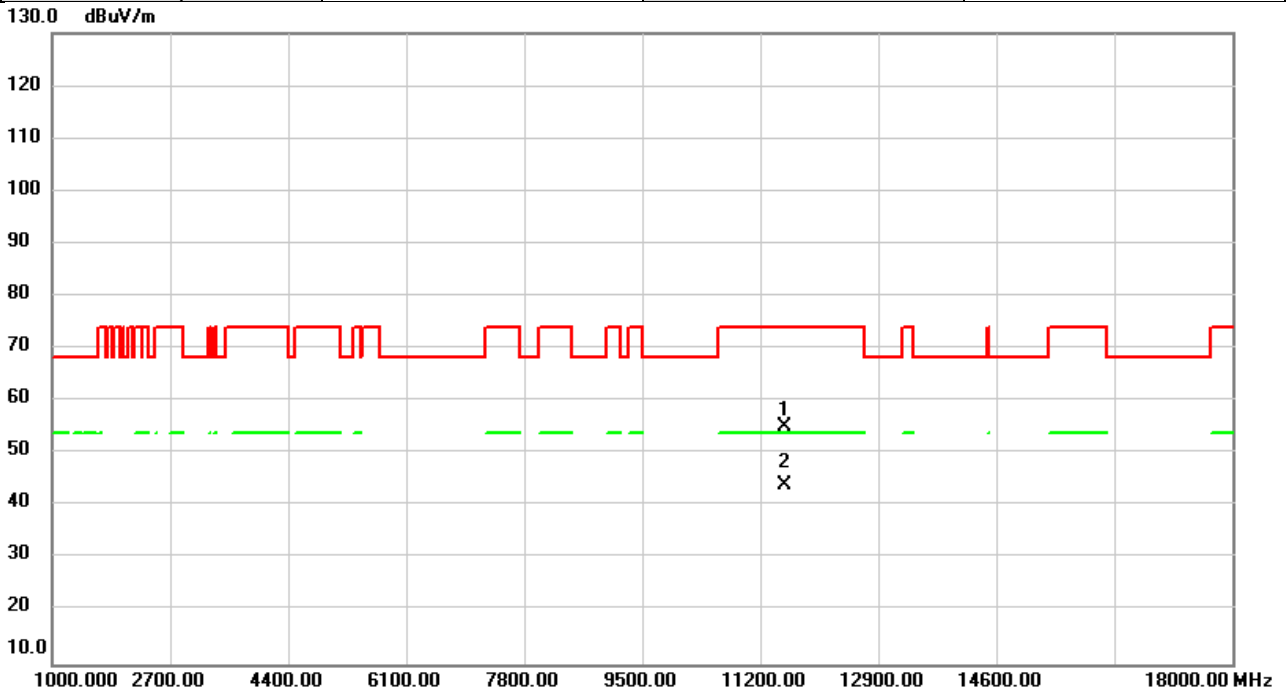

No.	Mk.	Freq. MHz	Reading Level dBuV	Correct Factor dB	Measure- ment dBuV/m	Limit dBuV/m	Over dB	Detector	Comment
1		11550.00	47.49	7.68	55.17	74.00	-18.83	peak	
2	*	11550.00	36.32	7.68	44.00	54.00	-10.00	AVG	

REMARKS:

- (1) Measurement Value = Reading Level + Correct Factor.
- (2) Margin Level = Measurement Value - Limit Value.

Test Mode	IEEE 802.11ac (VHT80)	Test Date	2024/3/26
Test Frequency	5775MHz	Polarization	Horizontal
Temp	24°C	Hum.	64%

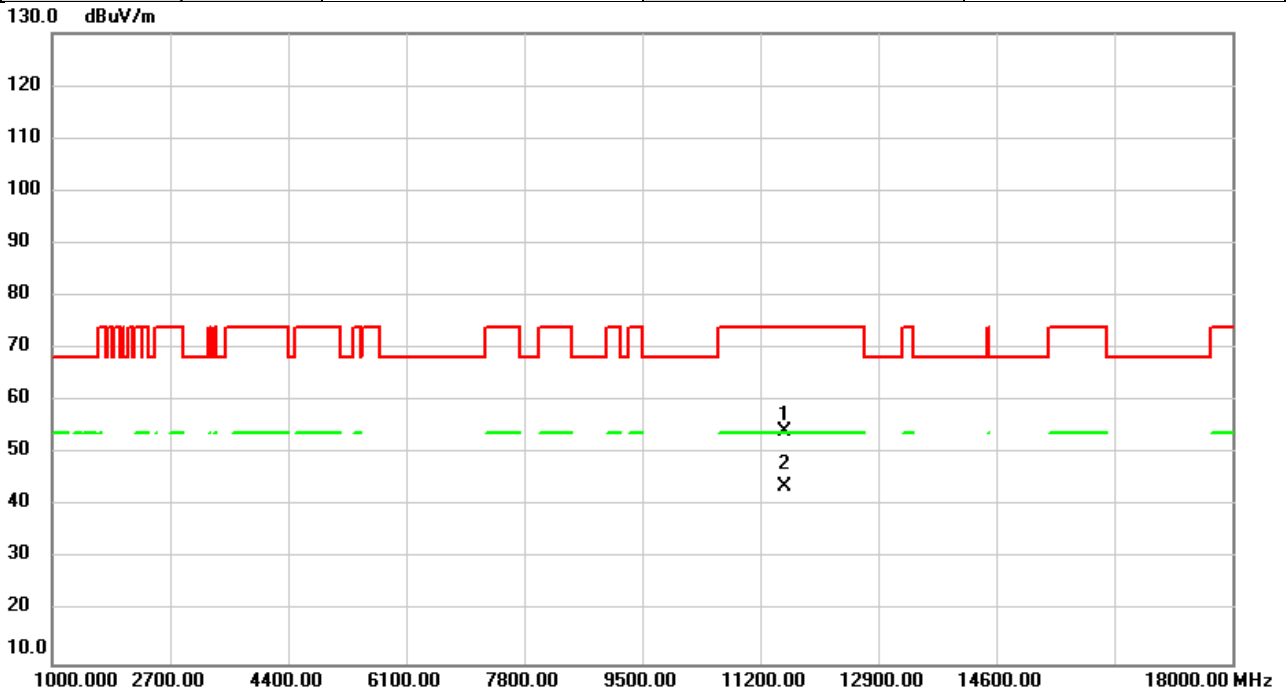

No.	Mk.	Freq.	Reading Level	Correct Factor	Measurement	Limit	Over	Detector	Comment
		MHz	dBuV	dB	dBuV/m	dBuV/m	dB		
1		11550.00	46.43	7.68	54.11	74.00	-19.89	peak	
2	*	11550.00	36.12	7.68	43.80	54.00	-10.20	AVG	

REMARKS:

- (1) Measurement Value = Reading Level + Correct Factor.
- (2) Margin Level = Measurement Value - Limit Value.

Test Mode	IEEE 802.11ac (VHT80)	Test Date	2024/3/26
Test Frequency	5290MHz	Polarization	Vertical
Temp	20°C	Hum.	60%

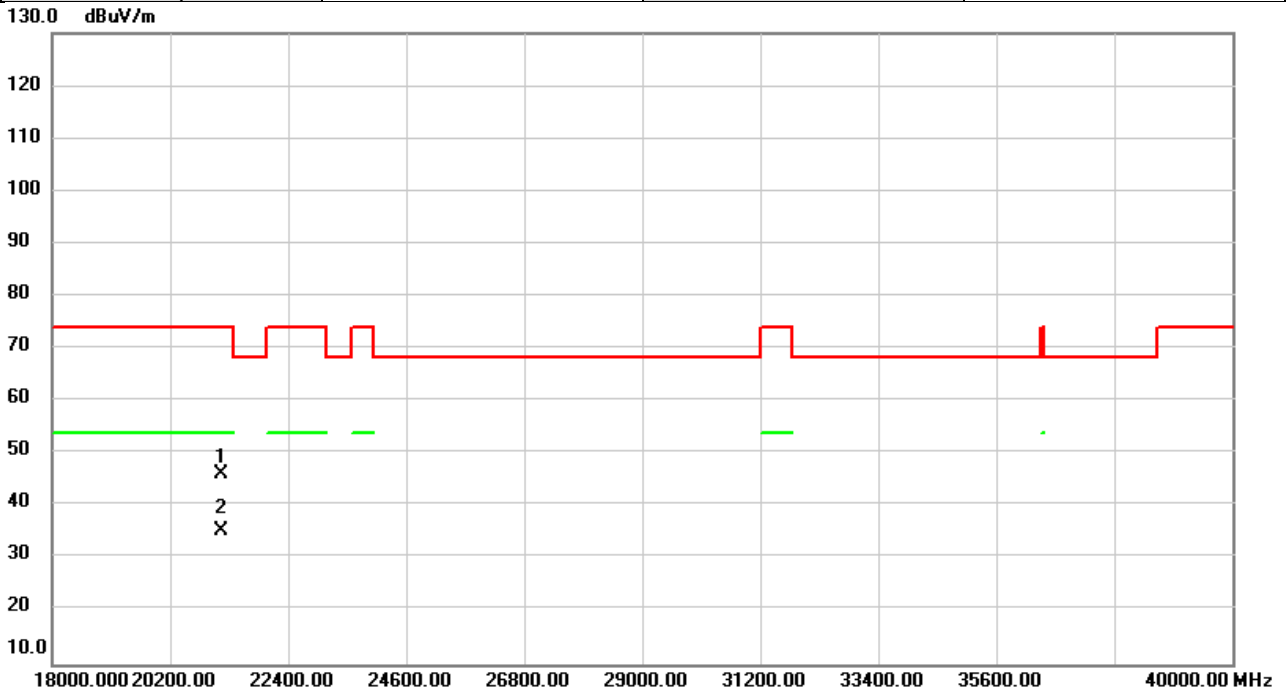

No.	Mk.	Freq. MHz	Reading Level dBuV	Correct Factor dB	Measure- ment dBuV/m	Limit dBuV/m	Over dB	Detector	Comment
1		21160.00	52.34	-6.15	46.19	74.00	-27.81	peak	
2	*	21160.00	41.63	-6.15	35.48	54.00	-18.52	AVG	

REMARKS:

- (1) Measurement Value = Reading Level + Correct Factor.
- (2) Margin Level = Measurement Value - Limit Value.

Test Mode	IEEE 802.11ac (VHT80)	Test Date	2024/3/26
Test Frequency	5290MHz	Polarization	Horizontal
Temp	20°C	Hum.	60%

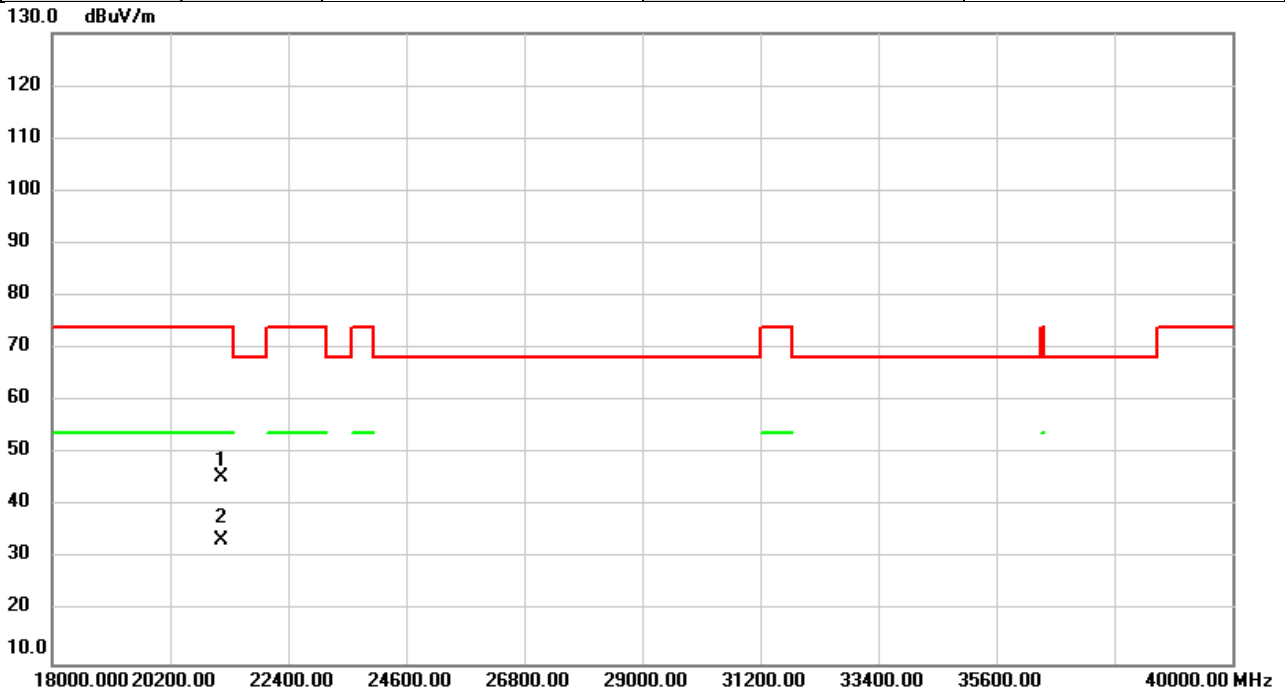

No.	Mk.	Freq.	Reading Level	Correct Factor	Measurement	Limit	Over	Detector	Comment
		MHz	dBuV	dB	dBuV/m	dBuV/m	dB		
1		21160.00	51.59	-6.15	45.44	74.00	-28.56	peak	
2	*	21160.00	39.64	-6.15	33.49	54.00	-20.51	AVG	

REMARKS:

- (1) Measurement Value = Reading Level + Correct Factor.
- (2) Margin Level = Measurement Value - Limit Value.

APPENDIX E BANDWIDTH

Test Mode	IEEE 802.11a
-----------	--------------

Test Frequency (MHz)	26 dB Bandwidth (MHz)	99 % Occupied Bandwidth (MHz)	Limit
5180	21.59	17.00	No limit
5200	21.50	17.00	No limit
5240	21.65	17.00	No limit

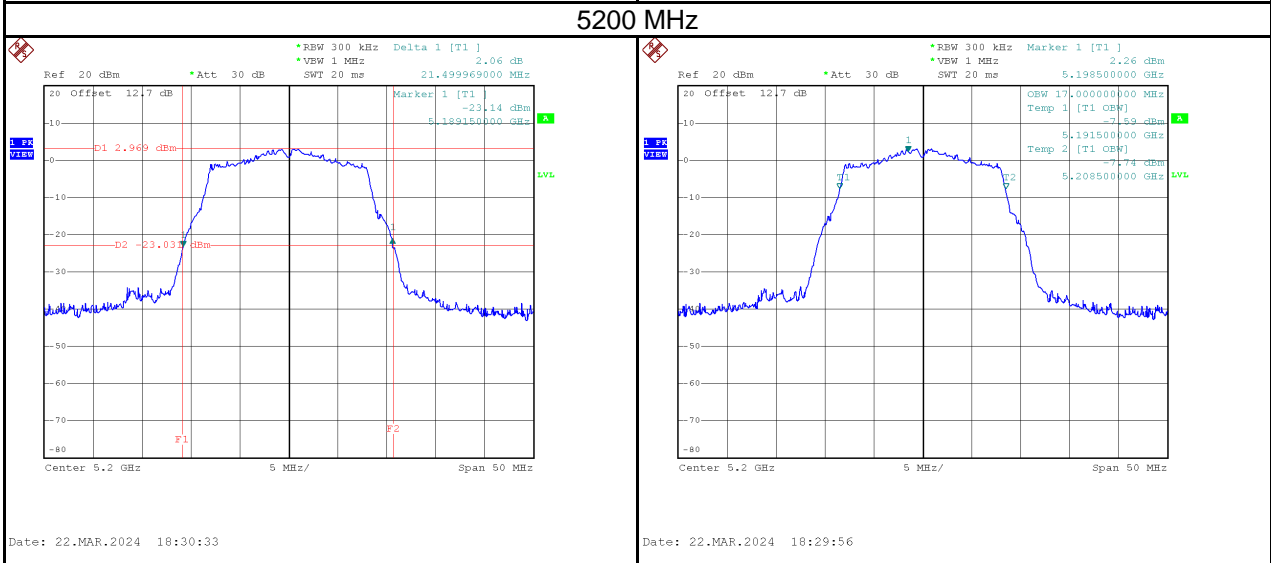
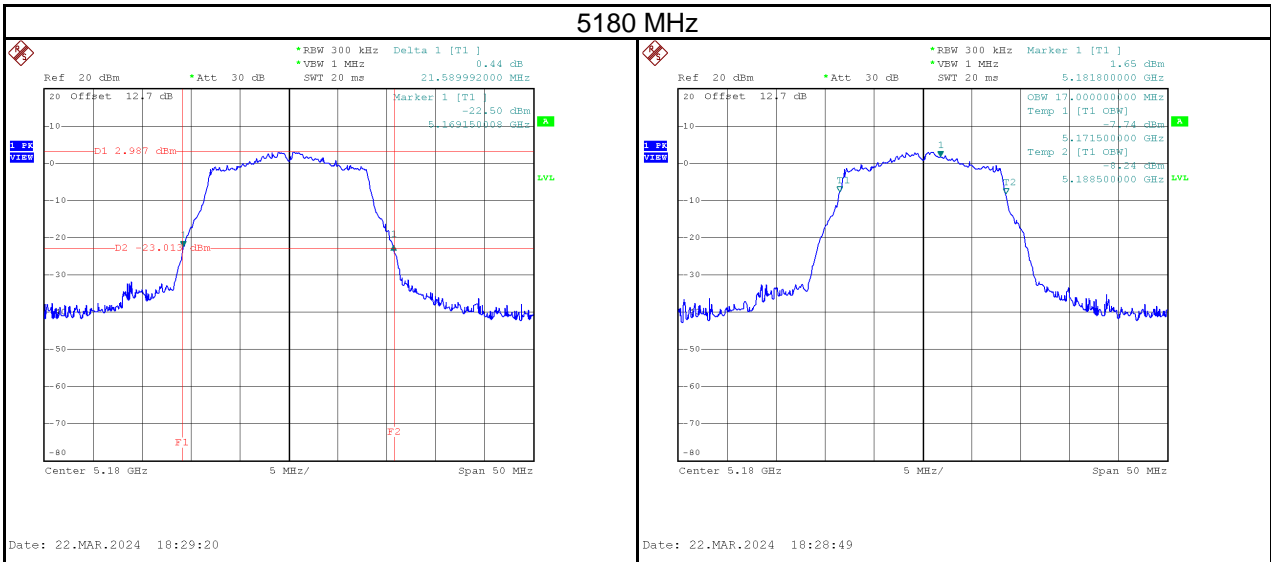

5240 MHz

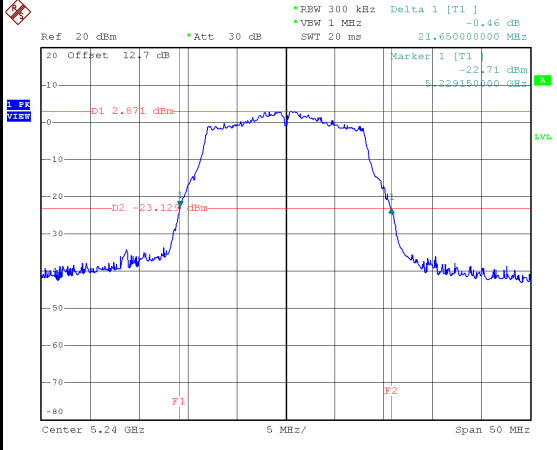

Date: 22.MAR.2024 18:31:50

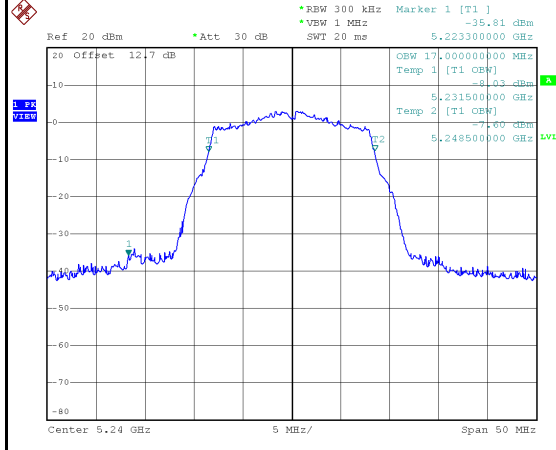

Date: 22.MAR.2024 18:31:18

Test Frequency (MHz)	26 dB Bandwidth (MHz)	99 % Occupied Bandwidth (MHz)	Limit
5260	21.65	17.00	No limit
5300	21.59	16.90	No limit
5320	21.59	17.10	No limit

5260 MHz

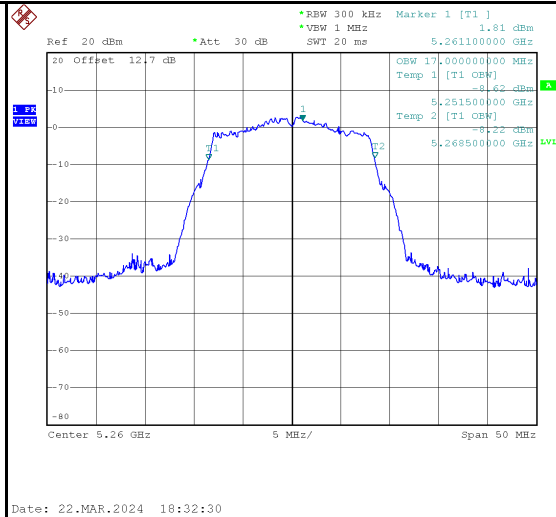
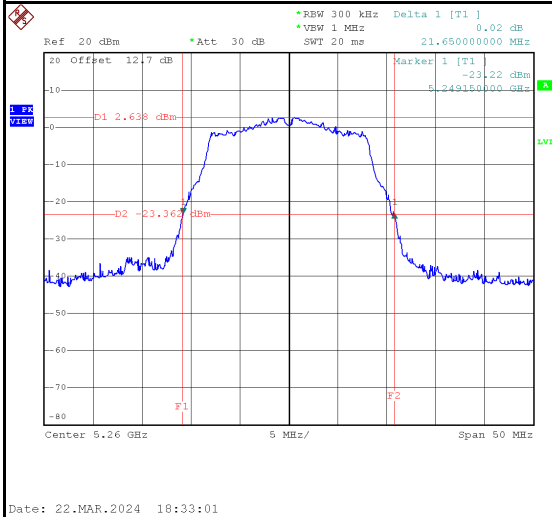

5300 MHz

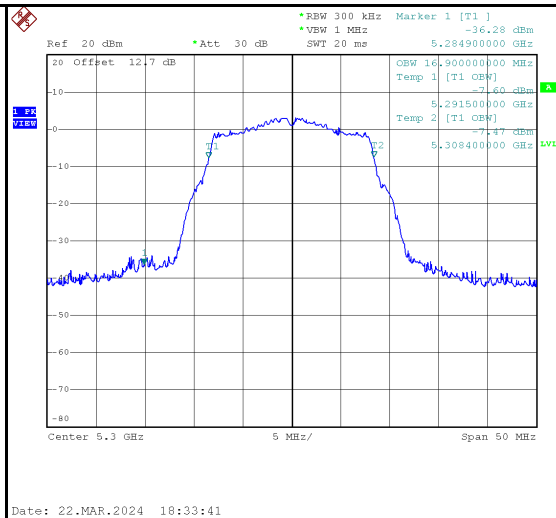
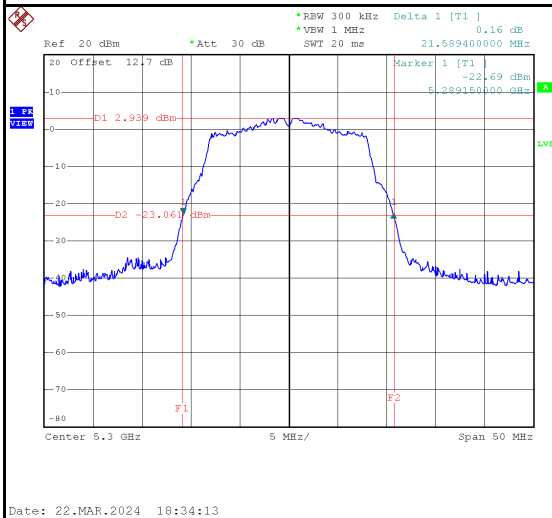

5320 MHz

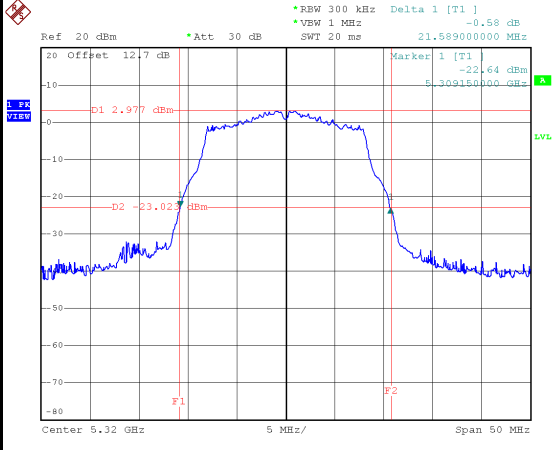

Date: 22.MAR.2024 18:35:21

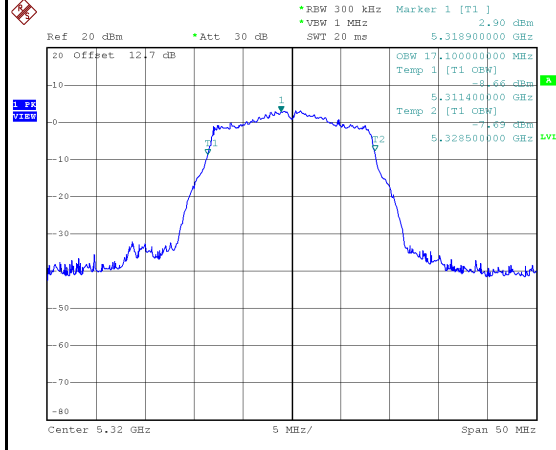

Date: 22.MAR.2024 18:34:50

Test Frequency (MHz)	26 dB Bandwidth (MHz)	99 % Occupied Bandwidth (MHz)	Limit
5500	21.65	17.00	No limit
5580	21.60	17.00	No limit
5700	21.61	17.10	No limit

5500 MHz

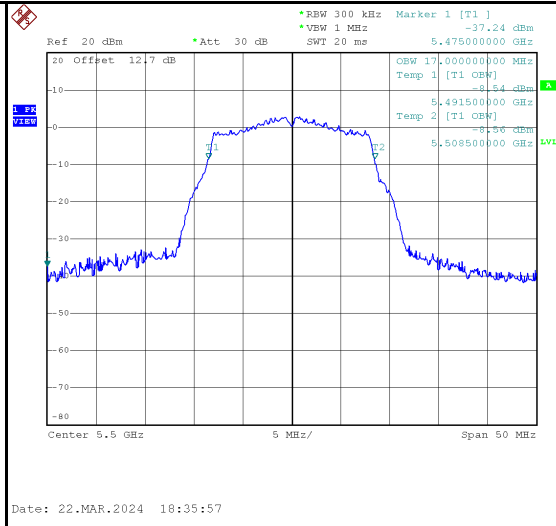
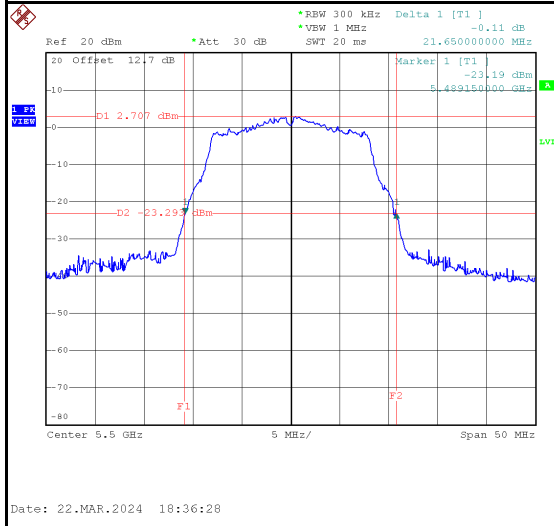

5580 MHz

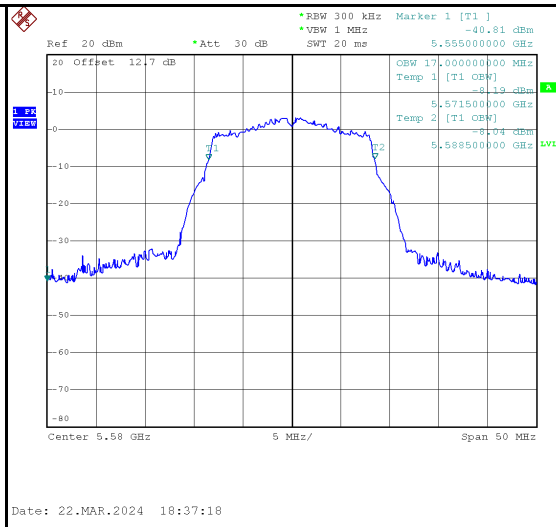
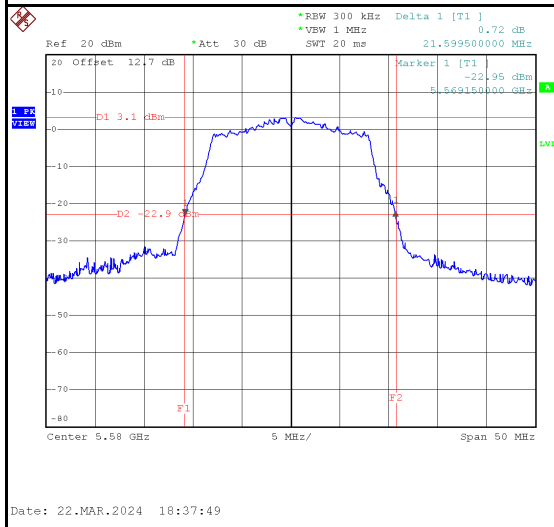

5700 MHz

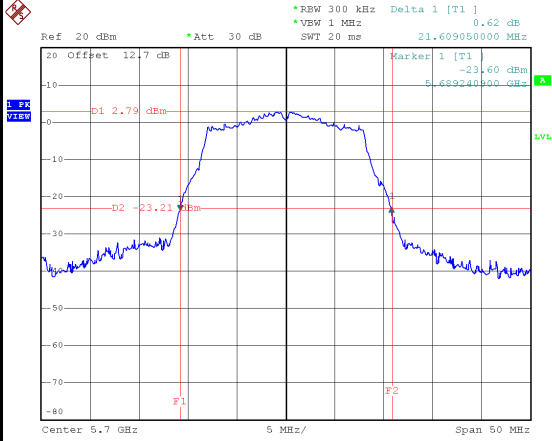

Date: 22.MAR.2024 18:39:02

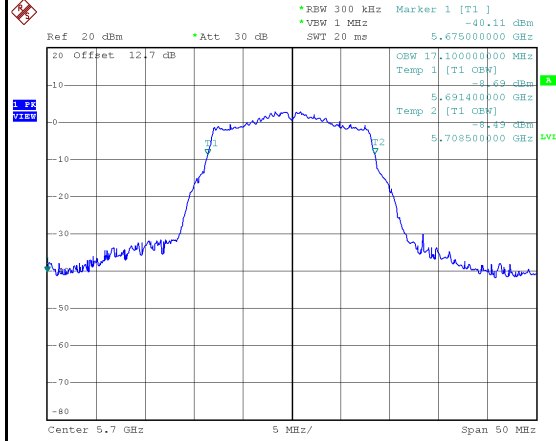

Date: 22.MAR.2024 18:38:30

Test Frequency (MHz)	6 dB Bandwidth (MHz)	99 % Occupied Bandwidth (MHz)	Minimum 6 dB Bandwidth Limit (kHz)	Result
5745	16.39	17.00	500	Pass
5785	16.35	17.00	500	Pass
5825	16.35	17.10	500	Pass

5745 MHz

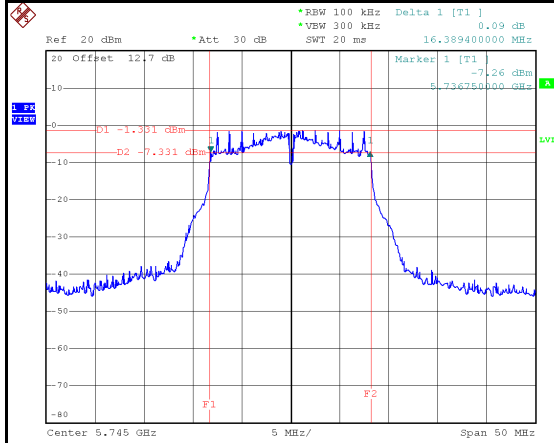

Date: 22.MAR.2024 10:40:25

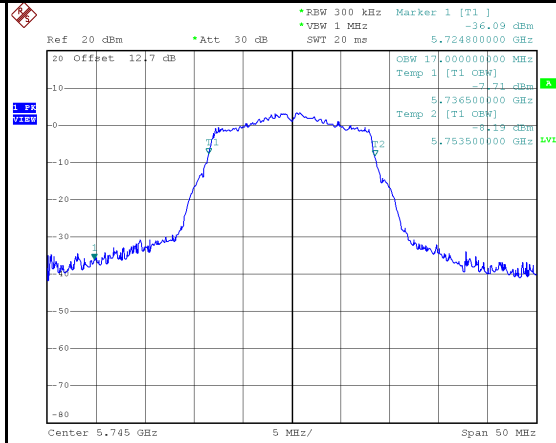

Date: 22.MAR.2024 10:39:49

5785 MHz

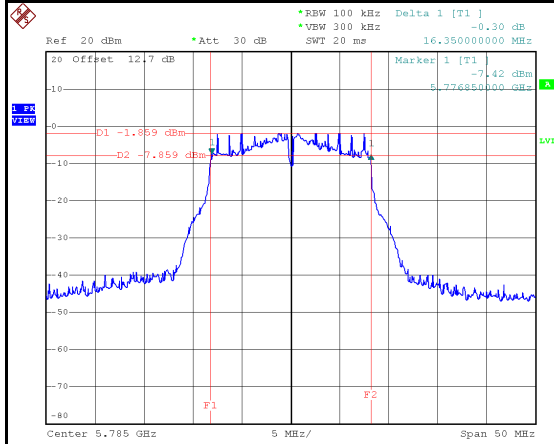

Date: 22.MAR.2024 10:41:41

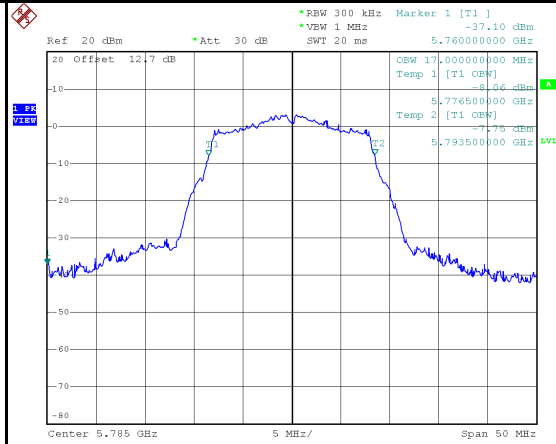

Date: 22.MAR.2024 10:41:04

5825 MHz

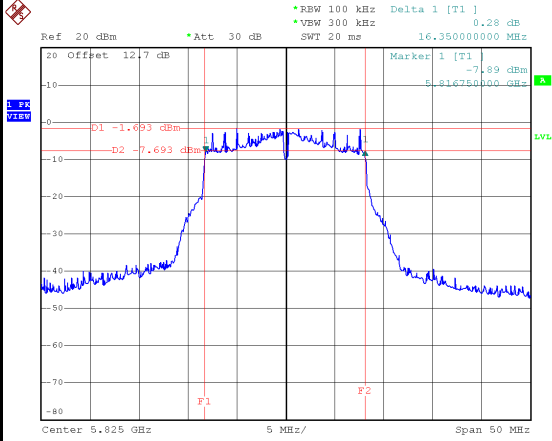

Date: 22.MAR.2024 18:42:54

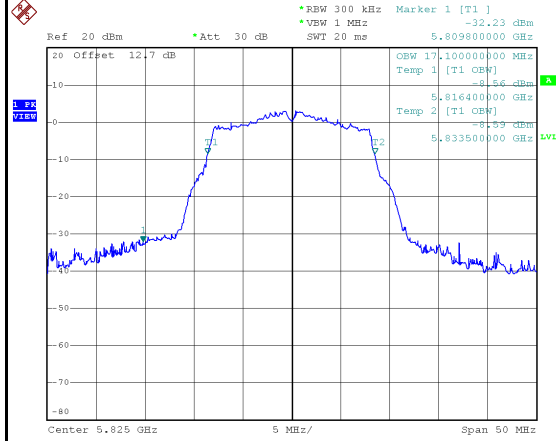

Date: 22.MAR.2024 18:42:18

Test Mode	IEEE 802.11n (HT20)
-----------	---------------------

Test Frequency (MHz)	26 dB Bandwidth (MHz)	99 % Occupied Bandwidth (MHz)	Limit
5180	21.70	18.20	No limit
5200	21.75	18.00	No limit
5240	21.79	18.20	No limit

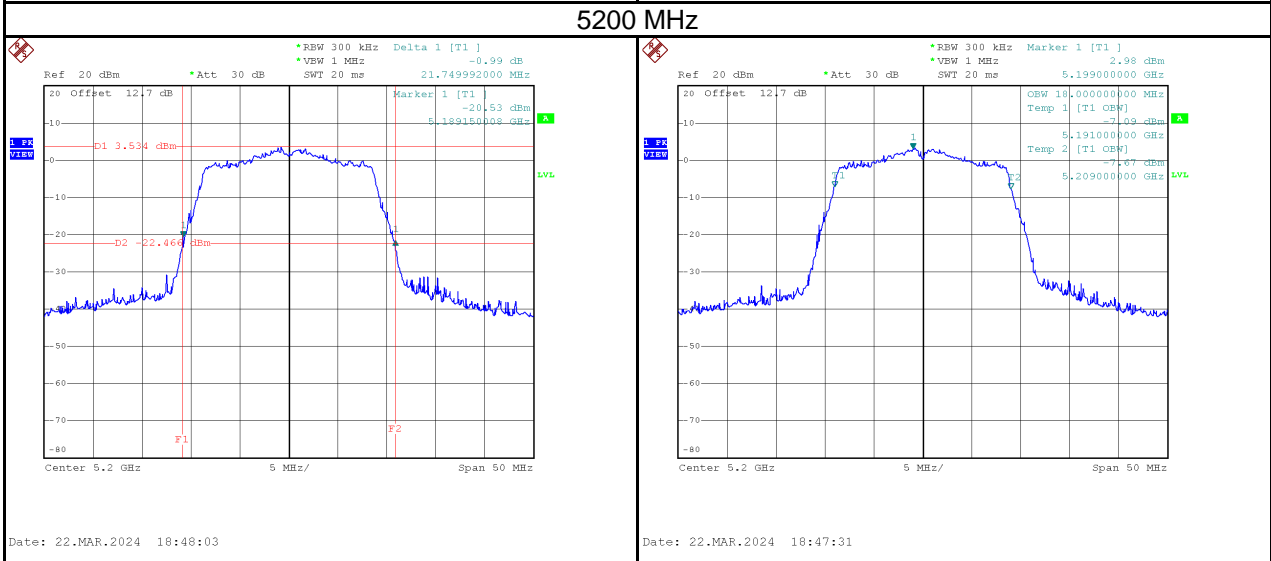
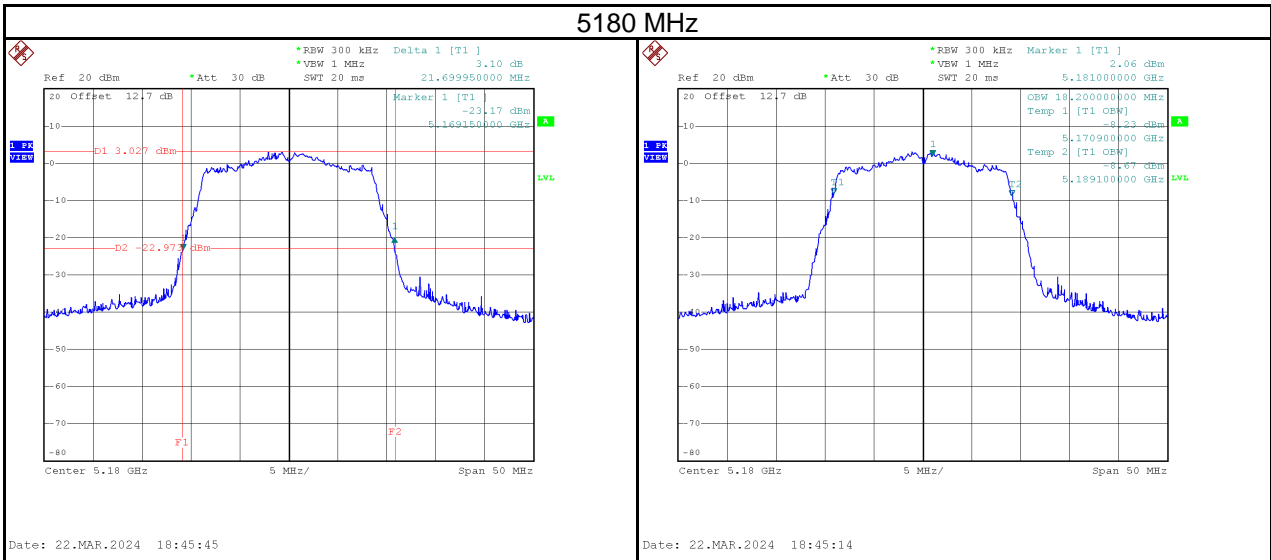

5240 MHz

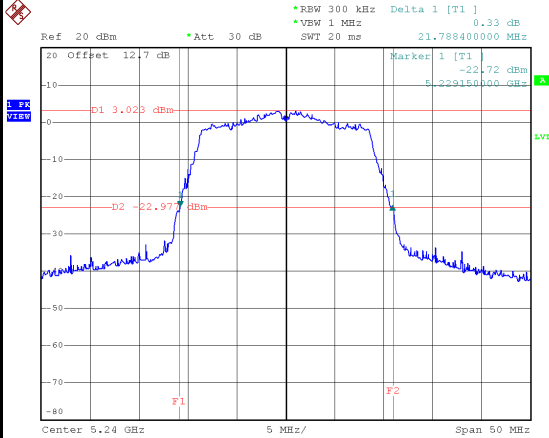

Date: 22.MAR.2024 18:49:27

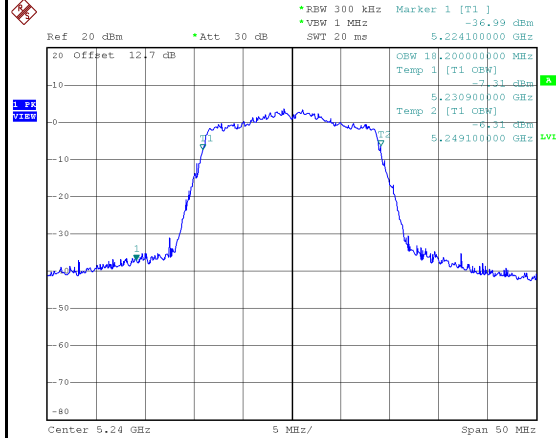

Date: 22.MAR.2024 18:48:56

Test Frequency (MHz)	26 dB Bandwidth (MHz)	99 % Occupied Bandwidth (MHz)	Limit
5260	21.61	18.00	No limit
5300	21.80	18.10	No limit
5320	21.70	18.00	No limit

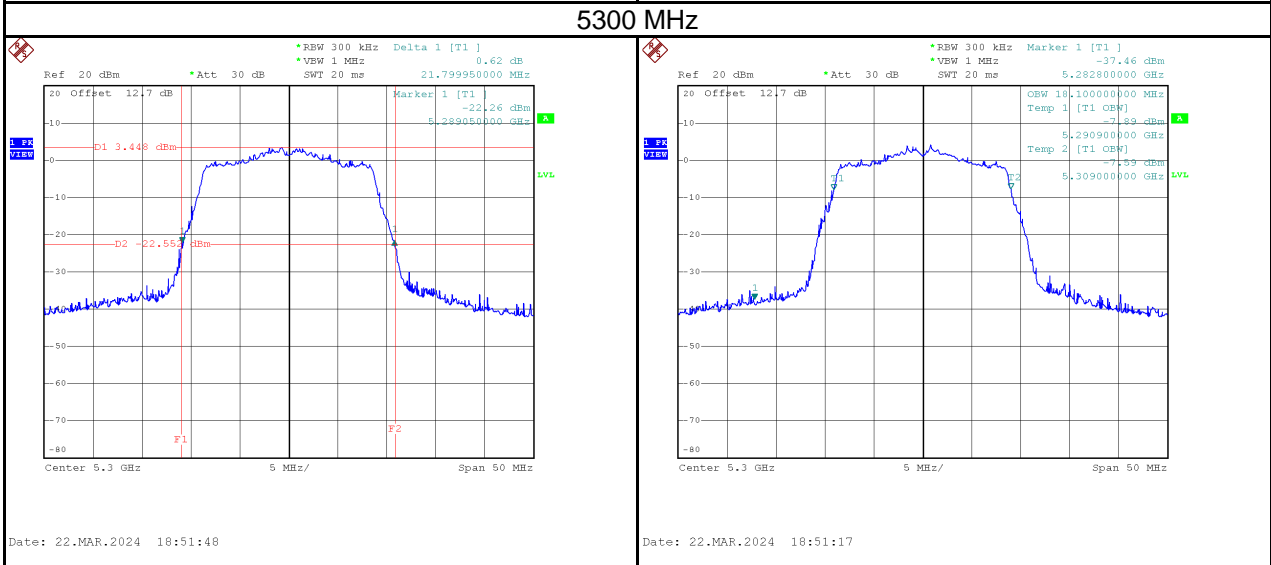
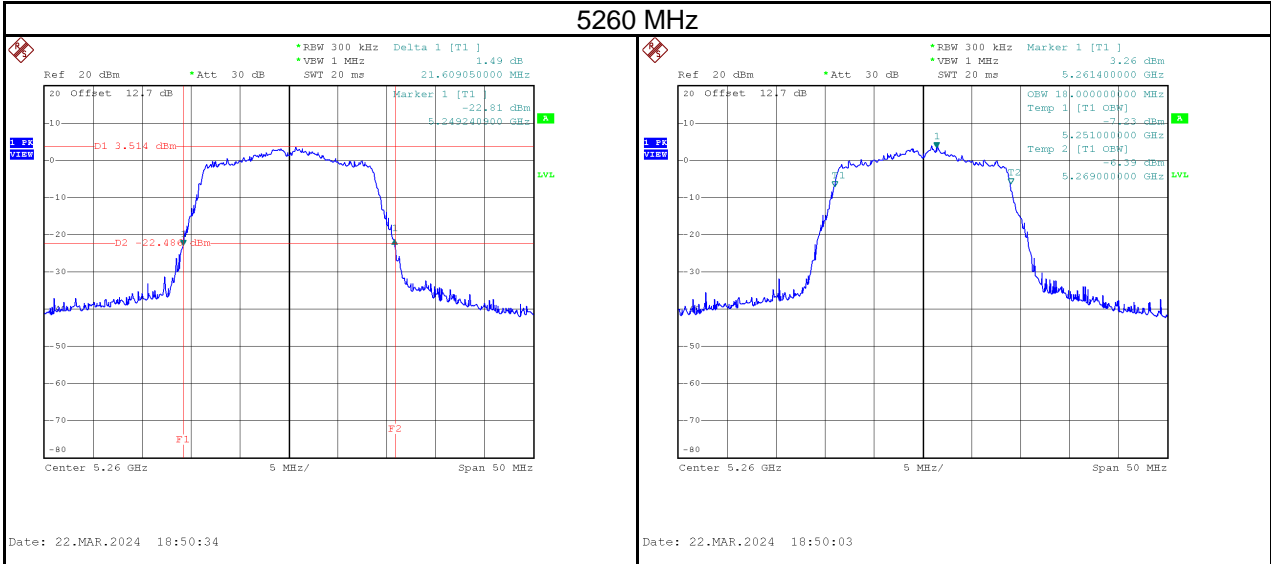

5320 MHz

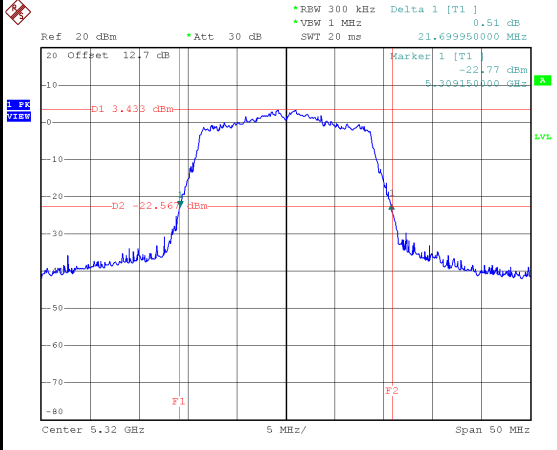

Date: 22.MAR.2024 18:52:53

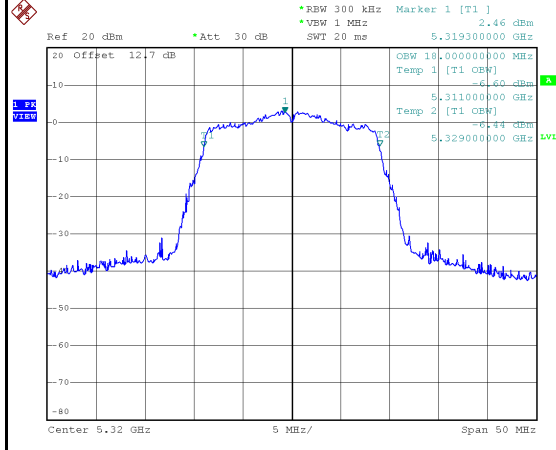

Date: 22.MAR.2024 18:52:20

Test Frequency (MHz)	26 dB Bandwidth (MHz)	99 % Occupied Bandwidth (MHz)	Limit
5500	21.80	18.00	No limit
5580	21.79	18.10	No limit
5700	21.85	18.10	No limit

5500 MHz

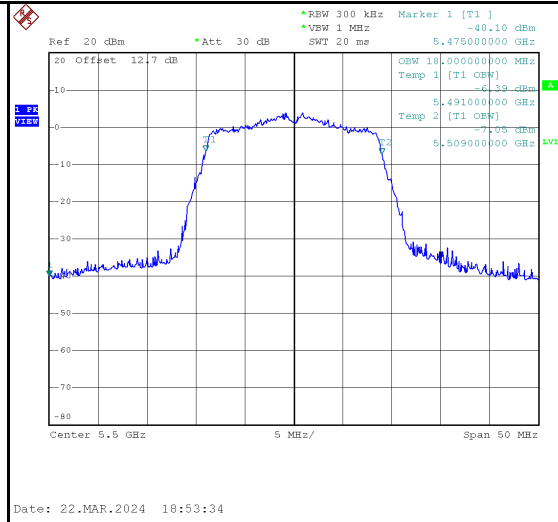
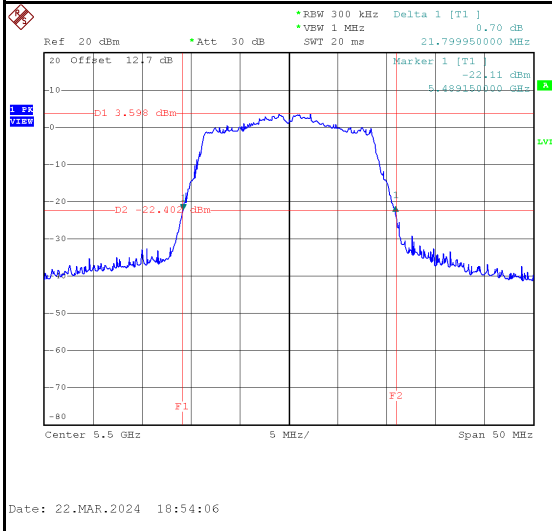

5580 MHz

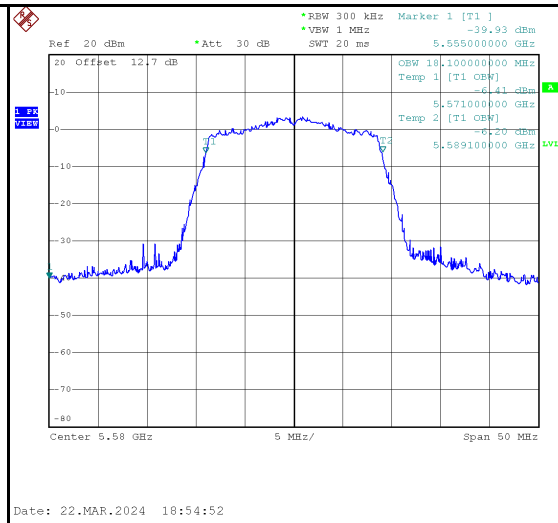
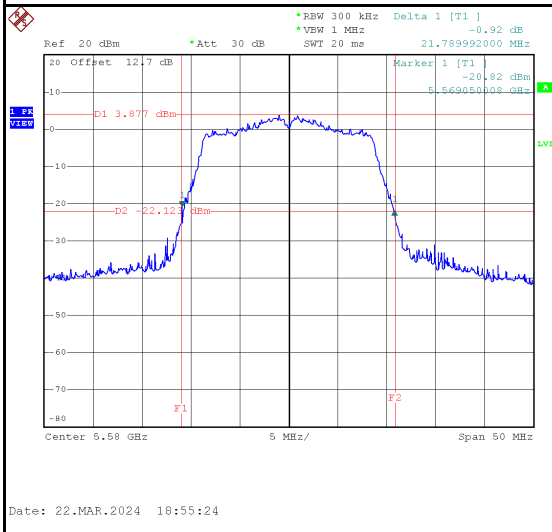

5700 MHz

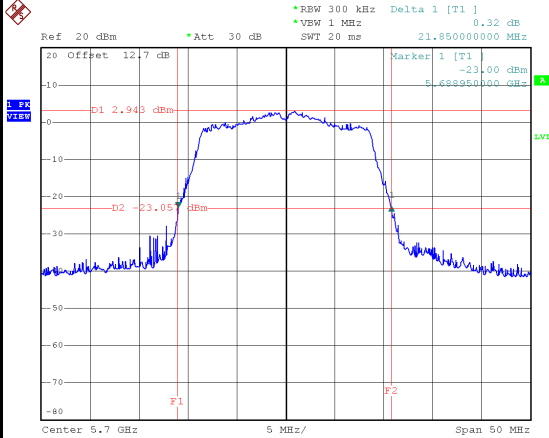

Date: 22.MAR.2024 18:56:31

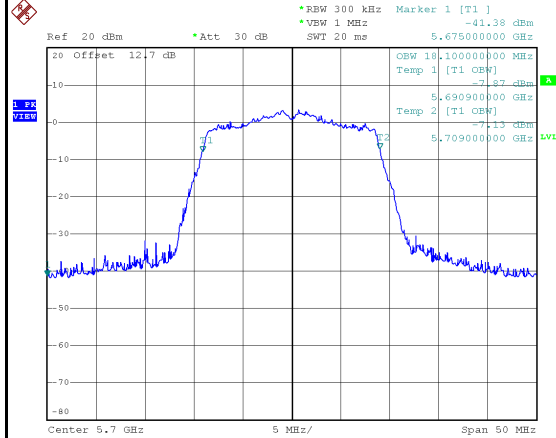

Date: 22.MAR.2024 18:56:00

Test Frequency (MHz)	6 dB Bandwidth (MHz)	99 % Occupied Bandwidth (MHz)	Minimum 6 dB Bandwidth Limit (kHz)	Result
5745	16.99	18.00	500	Pass
5785	17.55	18.00	500	Pass
5825	16.20	18.10	500	Pass

5745 MHz

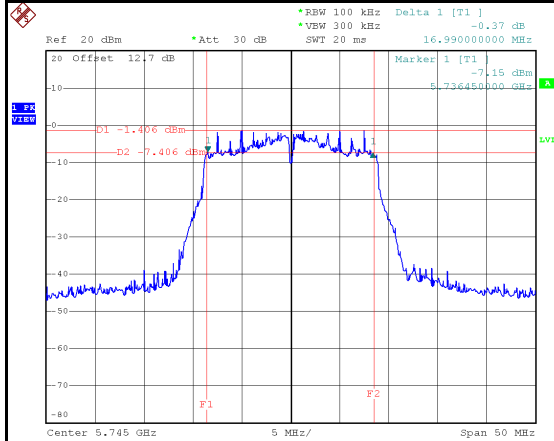

Date: 22.MAR.2024 10:57:50

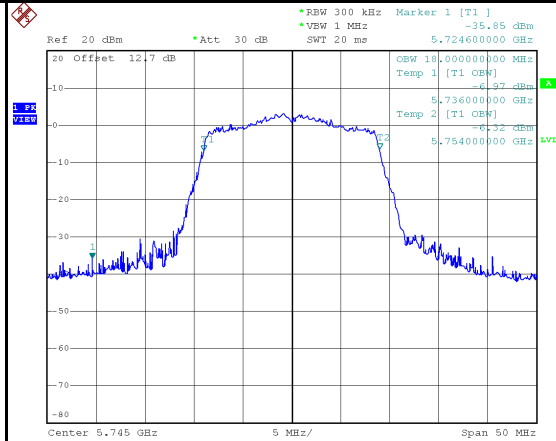

Date: 22.MAR.2024 10:57:13

5785 MHz

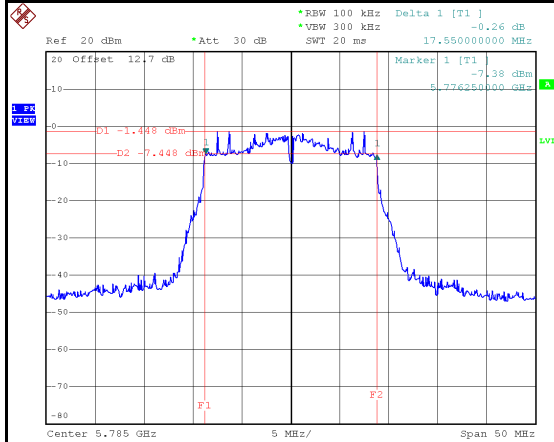

Date: 22.MAR.2024 10:59:04

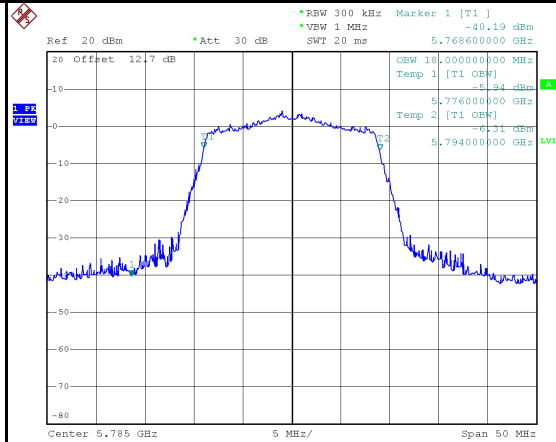

Date: 22.MAR.2024 10:58:28

5825 MHz

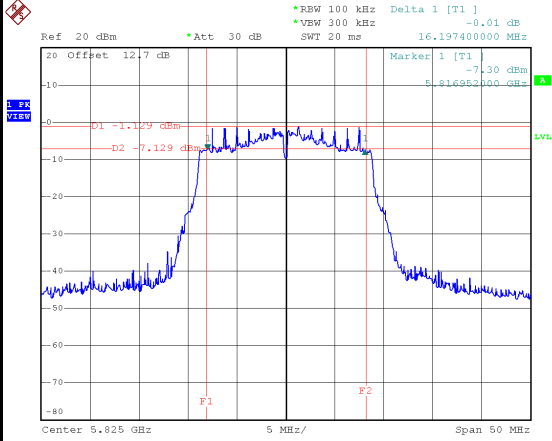

Date: 22.MAR.2024 19:00:15

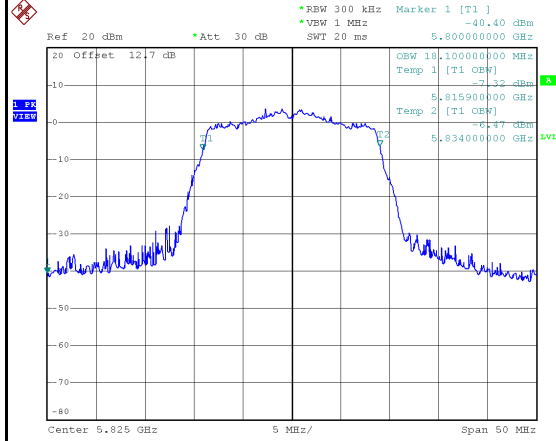

Date: 22.MAR.2024 18:59:36

Test Mode	IEEE 802.11n (HT40)
-----------	---------------------

Test Frequency (MHz)	26 dB Bandwidth (MHz)	99 % Occupied Bandwidth (MHz)	Limit
5190	39.50	36.60	No limit
5230	39.50	36.60	No limit

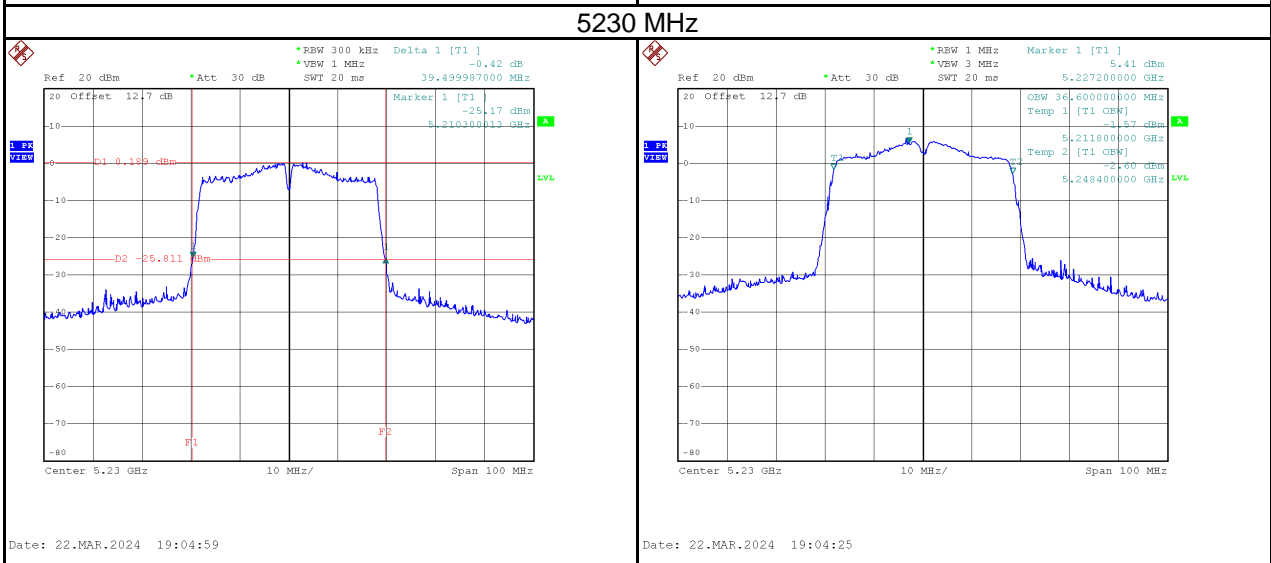
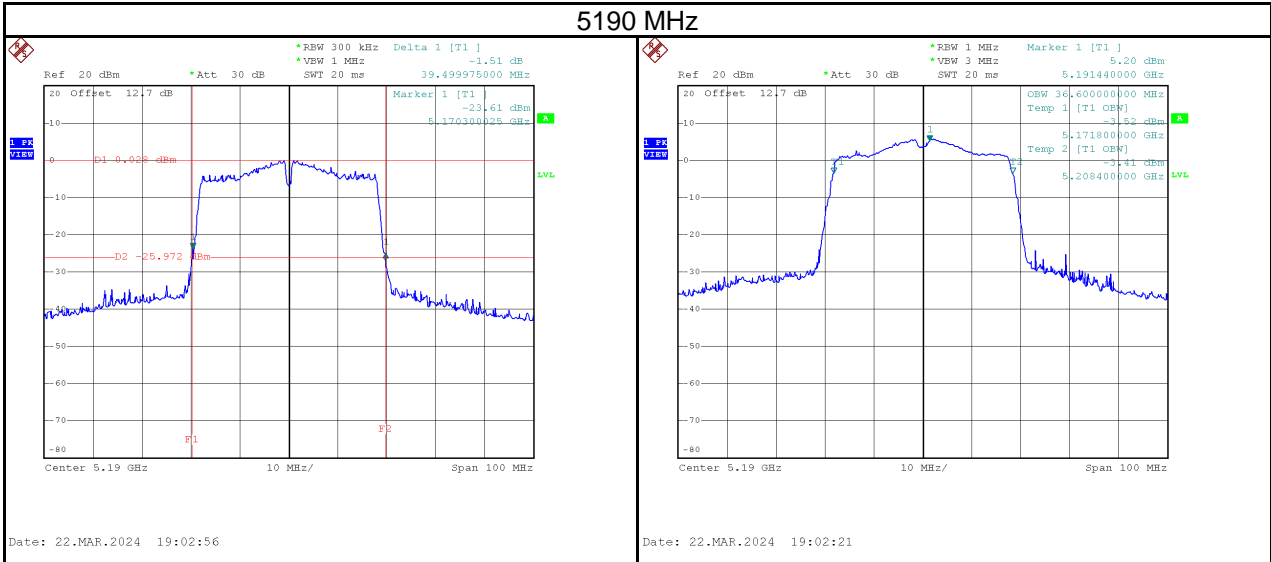

Test Frequency (MHz)	26 dB Bandwidth (MHz)	99 % Occupied Bandwidth (MHz)	Limit
5270	39.50	36.60	No limit
5310	39.80	36.60	No limit

5270 MHz

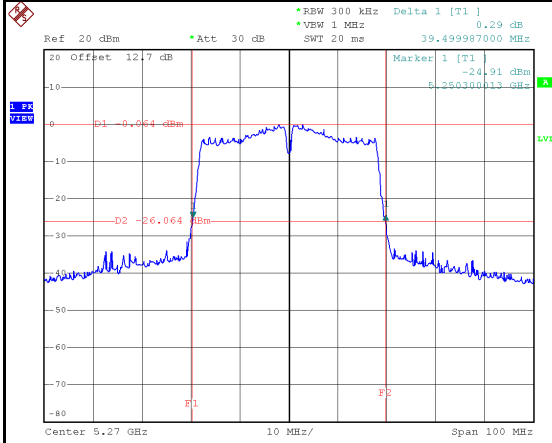

Date: 22.MAR.2024 19:06:20

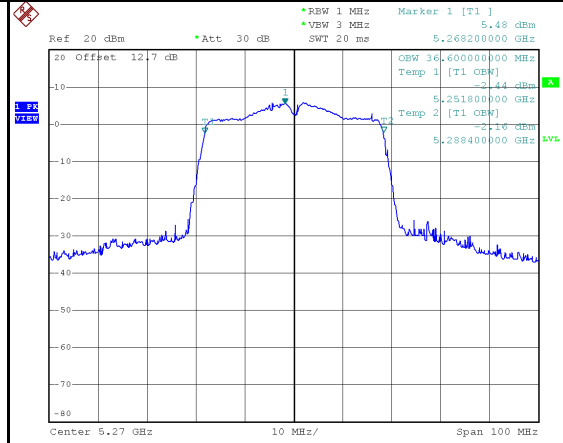

Date: 22.MAR.2024 19:05:46

5310 MHz

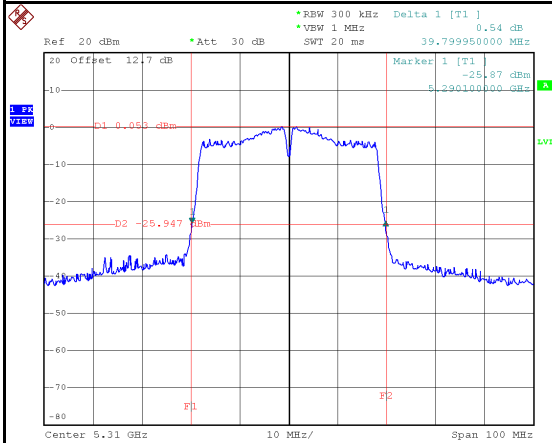

Date: 22.MAR.2024 19:08:02

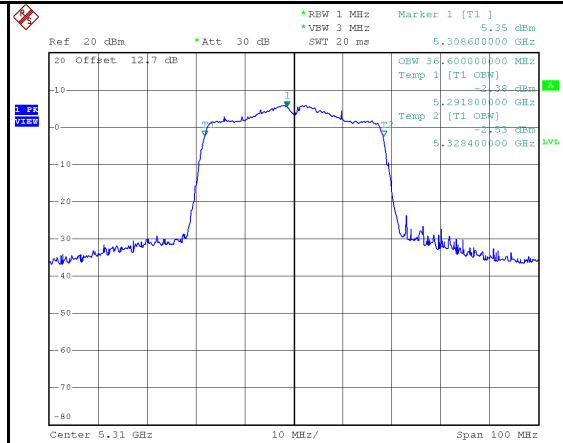

Date: 22.MAR.2024 19:07:29

Test Frequency (MHz)	26 dB Bandwidth (MHz)	99 % Occupied Bandwidth (MHz)	Limit
5510	39.60	36.60	No limit
5550	39.50	36.60	No limit
5670	39.70	36.60	No limit

5510 MHz

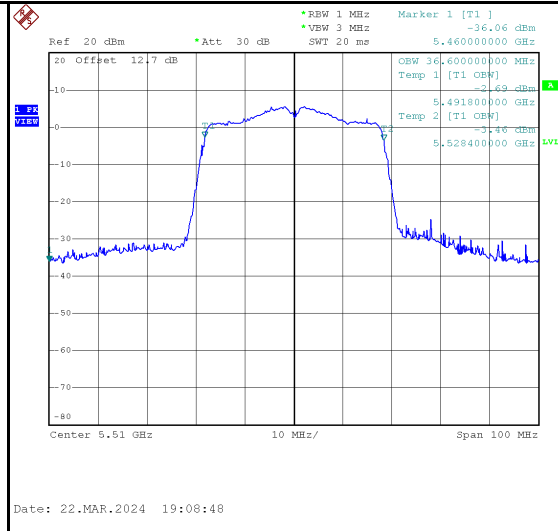
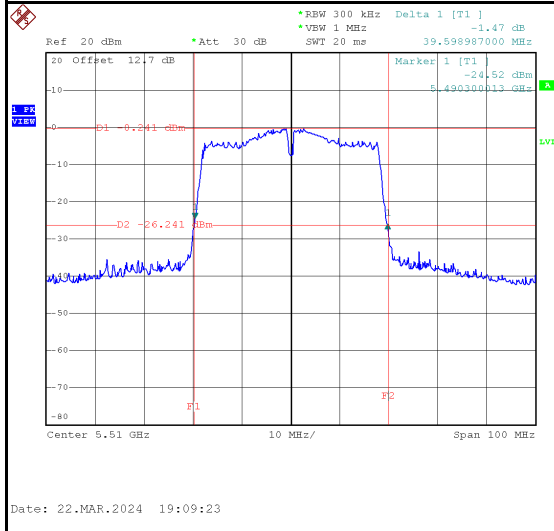

5550 MHz

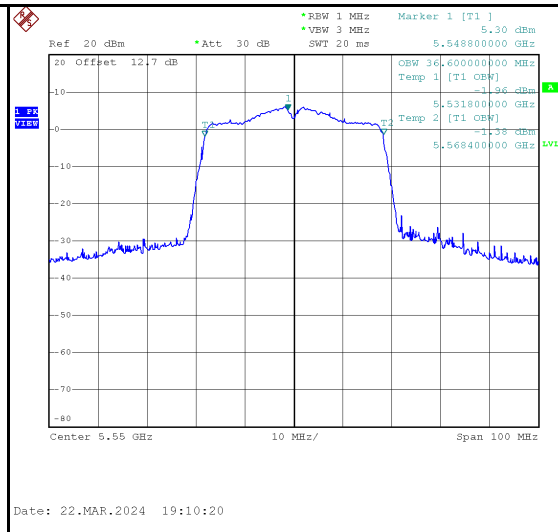
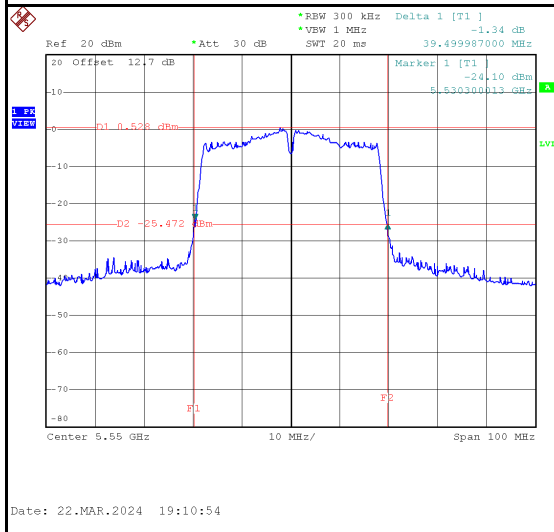

5670 MHz

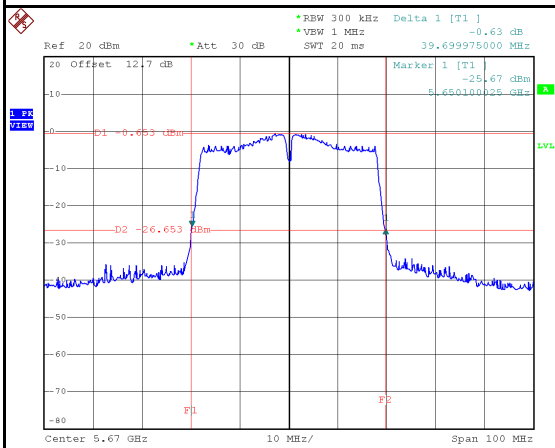

Date: 22.MAR.2024 19:12:24

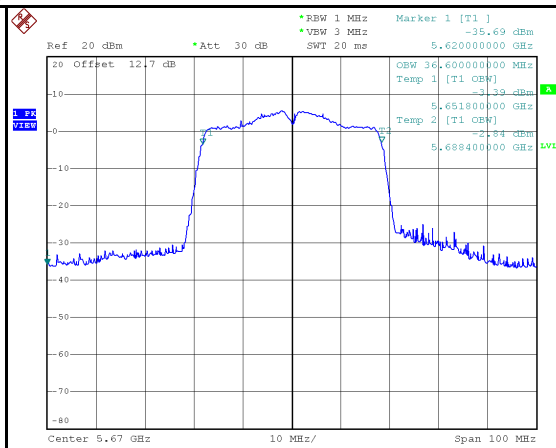

Date: 22.MAR.2024 19:11:49

Test Frequency (MHz)	6 dB Bandwidth (MHz)	99 % Occupied Bandwidth (MHz)	Minimum 6 dB Bandwidth Limit (kHz)	Result
5755	35.60	36.80	500	Pass
5795	35.40	36.80	500	Pass

5755 MHz

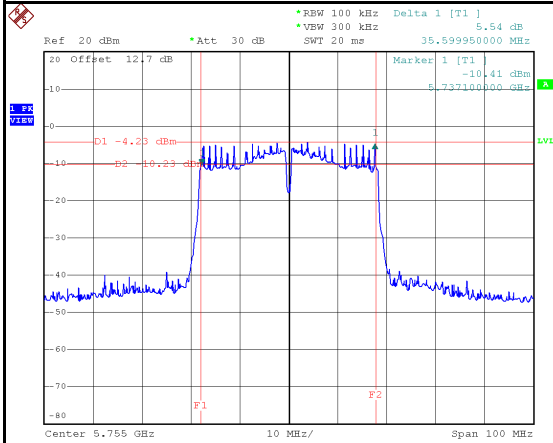

Date: 22.MAR.2024 19:13:53

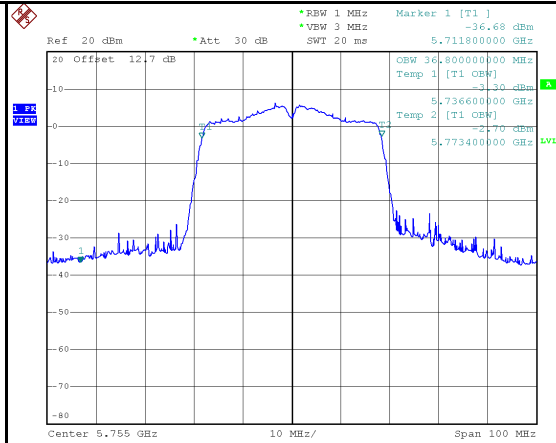

Date: 22.MAR.2024 19:13:14

5795 MHz

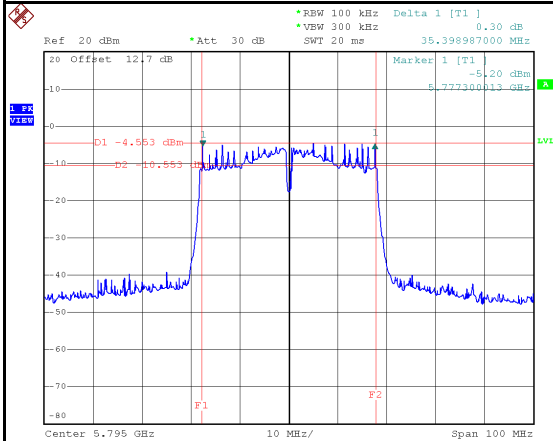

Date: 22.MAR.2024 19:15:23

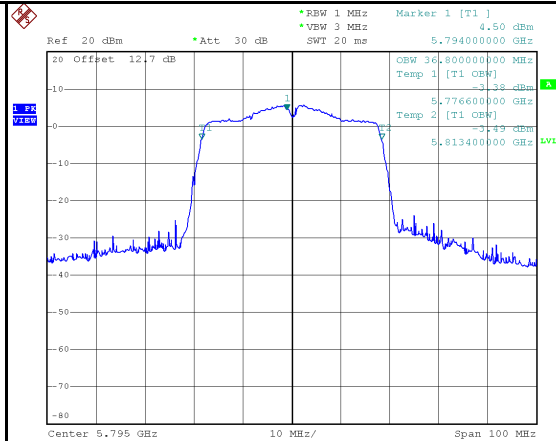

Date: 22.MAR.2024 19:14:46

Test Mode	IEEE 802.11ac (VHT80)
-----------	-----------------------

Test Frequency (MHz)	26 dB Bandwidth (MHz)	99 % Occupied Bandwidth (MHz)	Limit
5210	82.00	75.60	No limit

5210 MHz

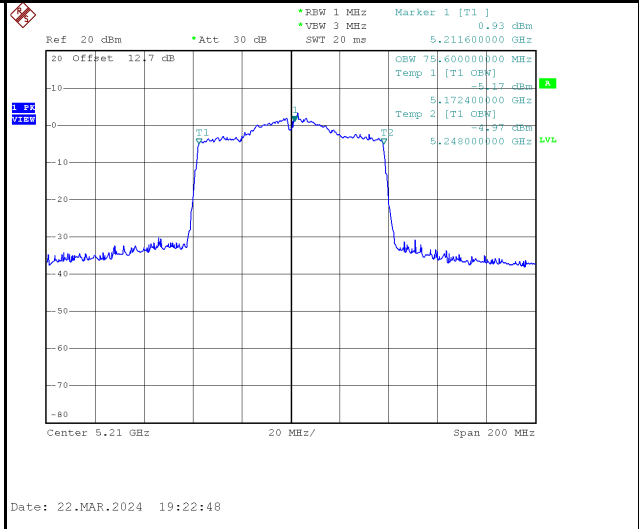
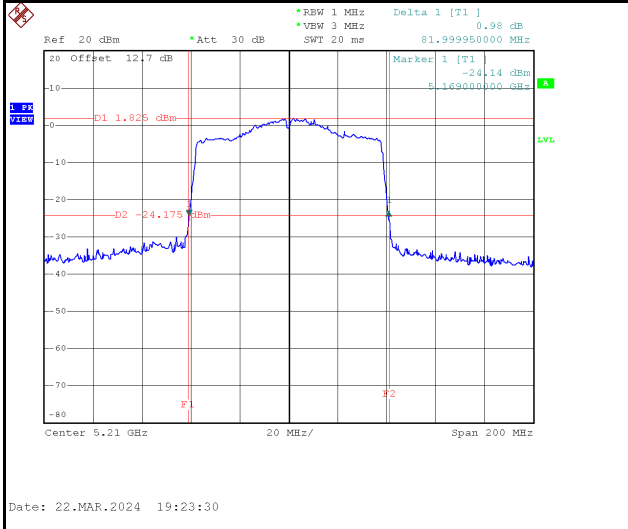

Test Frequency (MHz)	26 dB Bandwidth (MHz)	99 % Occupied Bandwidth (MHz)	Limit
5290	81.19	75.60	No limit

5290 MHz

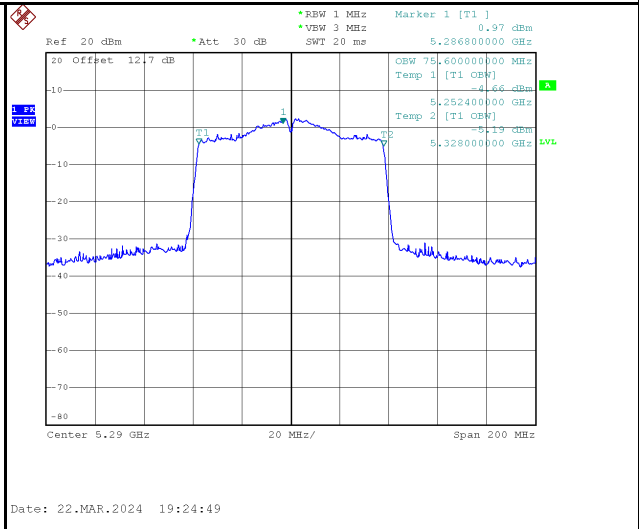
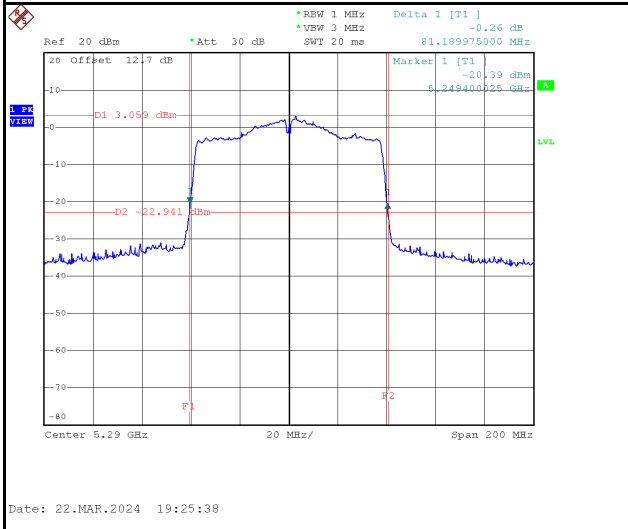

Test Frequency (MHz)	26 dB Bandwidth (MHz)	99 % Occupied Bandwidth (MHz)	Limit
5530	82.20	75.60	No limit
5610	81.60	75.60	No limit

5530 MHz

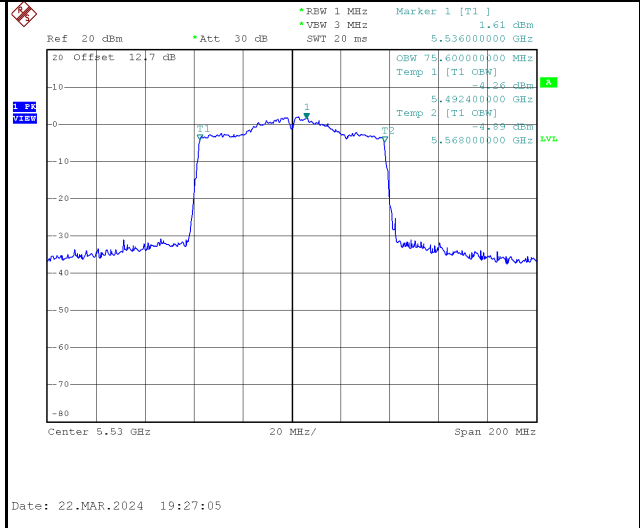
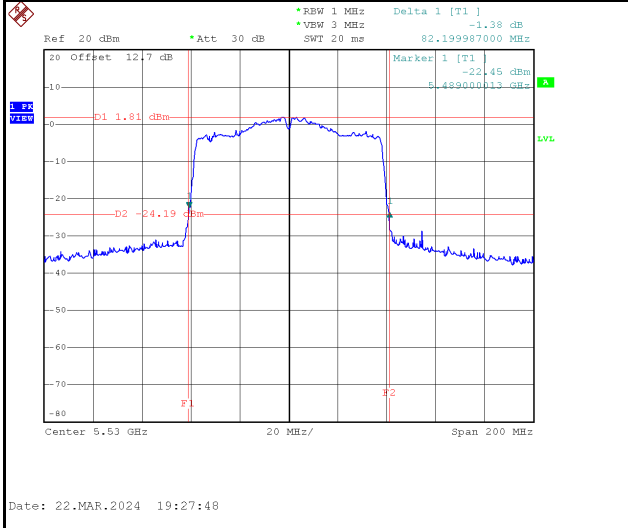

5610 MHz

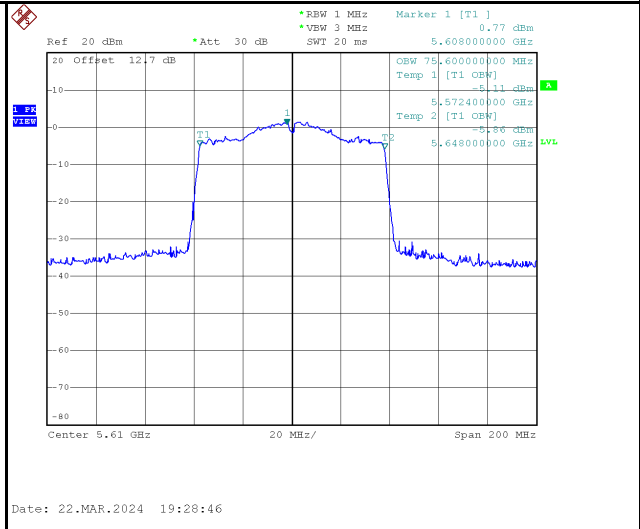
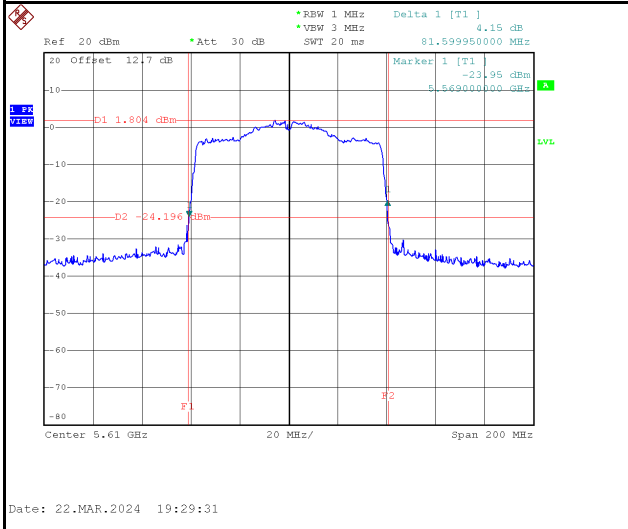

Test Frequency (MHz)	6 dB Bandwidth (MHz)	99 % Occupied Bandwidth (MHz)	Minimum 6 dB Bandwidth Limit (kHz)	Result
5775	75.80	75.60	500	Pass

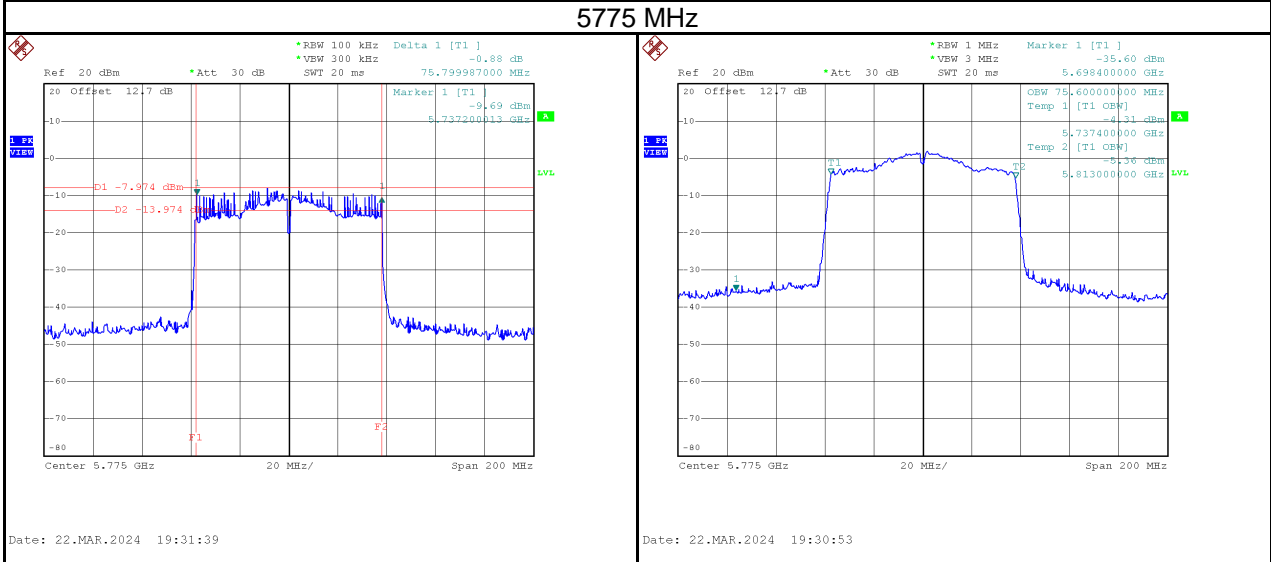

APPENDIX F CONDUCTED OUTPUT POWER

Test Mode	IEEE 802.11a	Tested Date	2024/3/21
-----------	--------------	-------------	-----------

Frequency (MHz)	Conducted Average Power (dBm)	Conducted Average Power (W)	Max. Limit (dBm)	Max. Limit (W)	Result
5180	12.92	0.0196	24.00	0.2512	Pass
5200	12.89	0.0195	24.00	0.2512	Pass
5240	12.99	0.0199	24.00	0.2512	Pass
5260	12.83	0.0192	24.00	0.2512	Pass
5300	12.92	0.0196	24.00	0.2512	Pass
5320	12.84	0.0192	24.00	0.2512	Pass
5500	12.93	0.0196	24.00	0.2512	Pass
5580	12.95	0.0197	24.00	0.2512	Pass
5700	12.67	0.0185	24.00	0.2512	Pass
5745	12.96	0.0198	30.00	1.0000	Pass
5785	12.98	0.0199	30.00	1.0000	Pass
5825	12.98	0.0199	30.00	1.0000	Pass

Test Mode	IEEE 802.11n (HT20)	Tested Date	2024/3/21
-----------	---------------------	-------------	-----------

Frequency (MHz)	Conducted Average Power (dBm)	Conducted Average Power (W)	Max. Limit (dBm)	Max. Limit (W)	Result
5180	12.92	0.0196	24.00	0.2512	Pass
5200	12.85	0.0193	24.00	0.2512	Pass
5240	12.90	0.0195	24.00	0.2512	Pass
5260	12.95	0.0197	24.00	0.2512	Pass
5300	12.75	0.0188	24.00	0.2512	Pass
5320	12.68	0.0185	24.00	0.2512	Pass
5500	12.98	0.0199	24.00	0.2512	Pass
5580	12.98	0.0199	24.00	0.2512	Pass
5700	12.88	0.0194	24.00	0.2512	Pass
5745	12.93	0.0196	30.00	1.0000	Pass
5785	12.95	0.0197	30.00	1.0000	Pass
5825	12.98	0.0199	30.00	1.0000	Pass

Test Mode	IEEE 802.11n (HT40)	Tested Date	2024/3/21
-----------	---------------------	-------------	-----------

Frequency (MHz)	Conducted Average Power (dBm)	Conducted Average Power (W)	Max. Limit (dBm)	Max. Limit (W)	Result
5190	11.82	0.0152	24.00	0.2512	Pass
5230	11.97	0.0157	24.00	0.2512	Pass
5270	11.90	0.0155	24.00	0.2512	Pass
5310	11.88	0.0154	24.00	0.2512	Pass
5510	11.76	0.0150	24.00	0.2512	Pass
5550	11.98	0.0158	24.00	0.2512	Pass
5670	11.93	0.0156	24.00	0.2512	Pass
5755	11.92	0.0156	30.00	1.0000	Pass
5795	11.97	0.0157	30.00	1.0000	Pass

Test Mode	IEEE 802.11ac (VHT80)	Tested Date	2024/3/21
-----------	-----------------------	-------------	-----------

Frequency (MHz)	Conducted Average Power (dBm)	Conducted Average Power (W)	Max. Limit (dBm)	Max. Limit (W)	Result
5210	10.29	0.0107	24.00	0.2512	Pass
5290	10.32	0.0108	24.00	0.2512	Pass
5530	10.46	0.0111	24.00	0.2512	Pass
5610	10.37	0.0109	24.00	0.2512	Pass
5775	10.05	0.0101	30.00	1.0000	Pass

APPENDIX G POWER SPECTRAL DENSITY

Test Mode	IEEE 802.11a
-----------	--------------

Test Frequency (MHz)	Power Density (dBm/MHz)	Duty Factor (dB)	Calculated Power Density (dBm/MHz)	Maximum Limit (dBm/MHz)	Result
5180	-0.43	0.34	-0.09	17.00	Pass
5200	-0.86	0.34	-0.52	17.00	Pass
5240	-0.90	0.34	-0.56	17.00	Pass

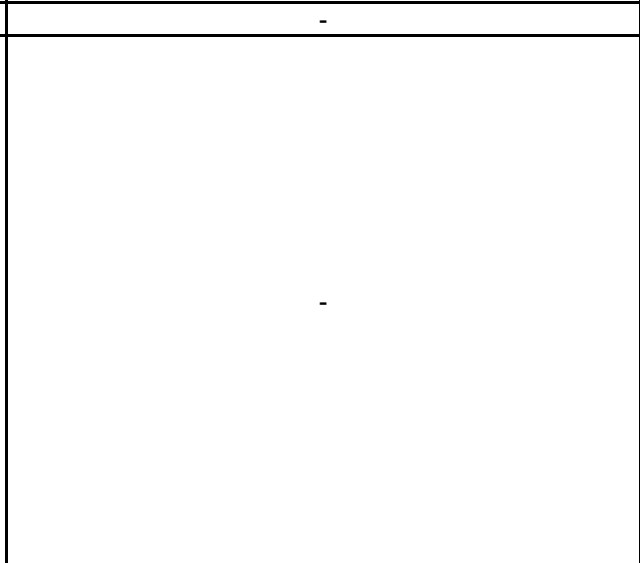
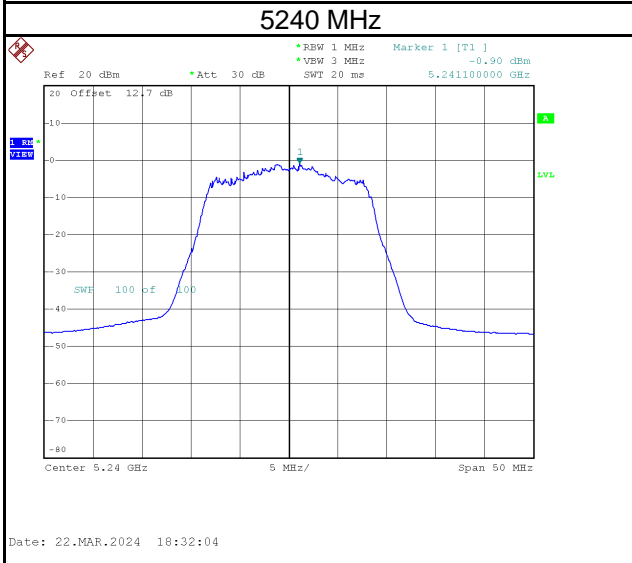
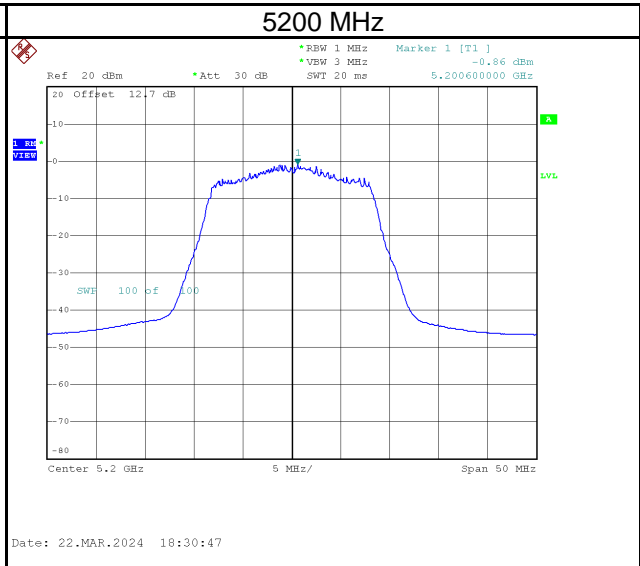
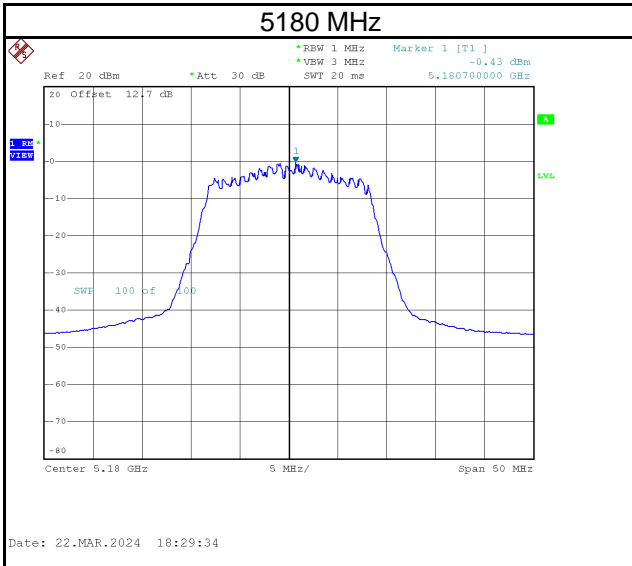

Test Frequency (MHz)	Power Density (dBm/MHz)	Duty Factor (dB)	Calculated Power Density (dBm/MHz)	Maximum Limit (dBm/MHz)	Result
5260	-1.15	0.34	-0.81	11.00	Pass
5300	-0.87	0.34	-0.53	11.00	Pass
5320	-0.39	0.34	-0.05	11.00	Pass

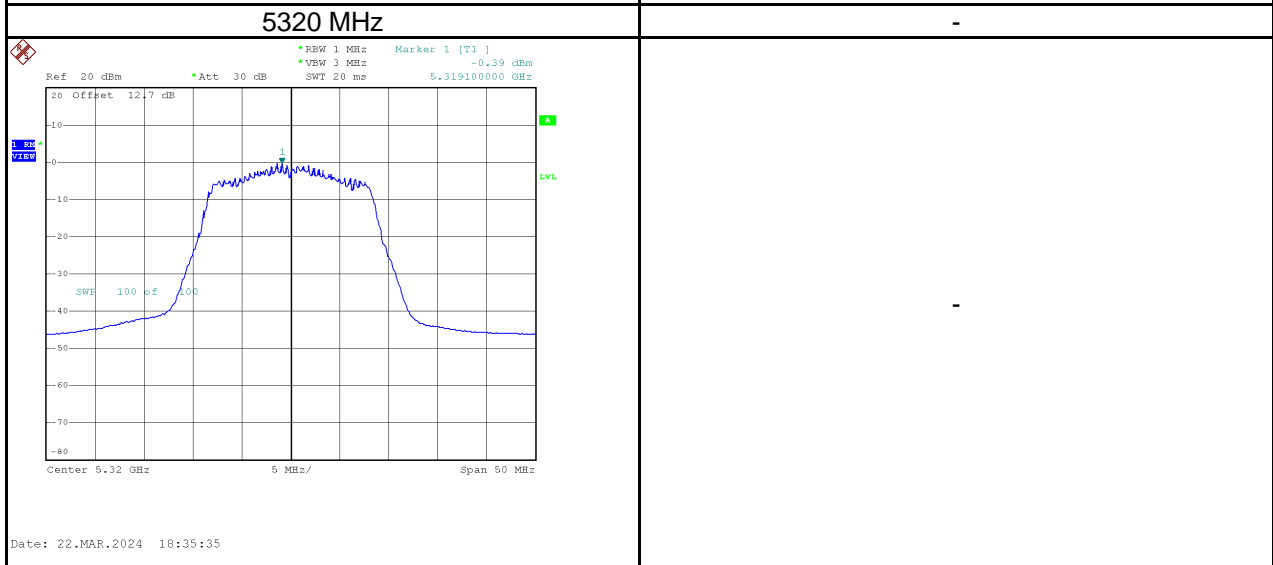
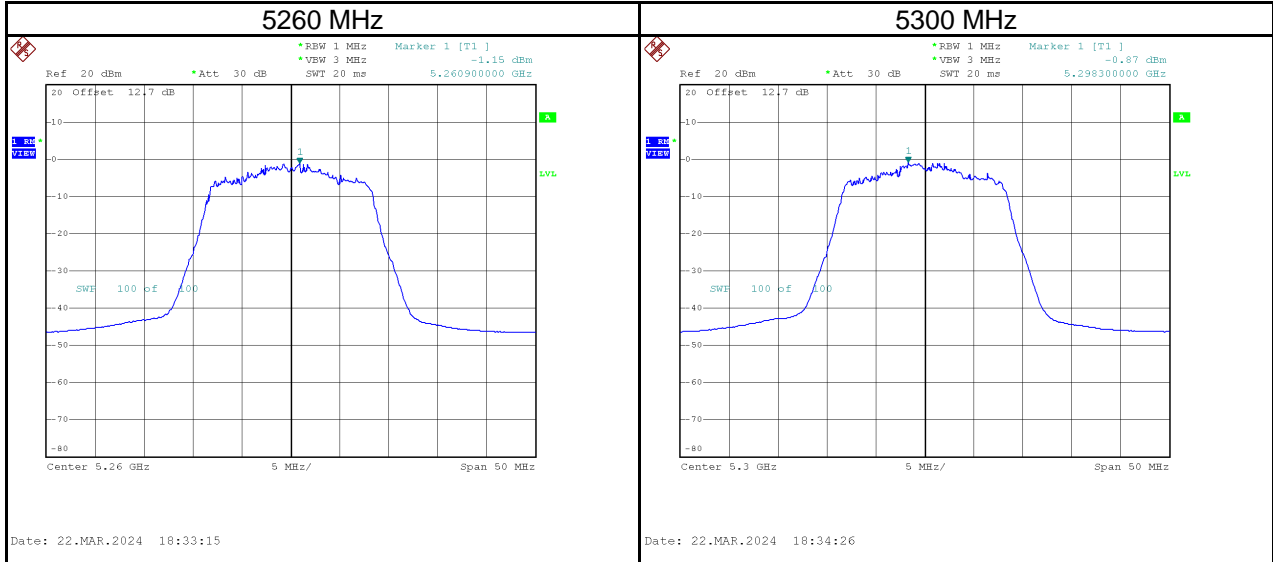

Test Frequency (MHz)	Power Density (dBm/MHz)	Duty Factor (dB)	Calculated Power Density (dBm/MHz)	Maximum Limit (dBm/MHz)	Result
5500	-0.84	0.34	-0.84	11.00	Pass
5580	-0.18	0.34	-0.18	11.00	Pass
5700	-0.65	0.34	-0.65	11.00	Pass

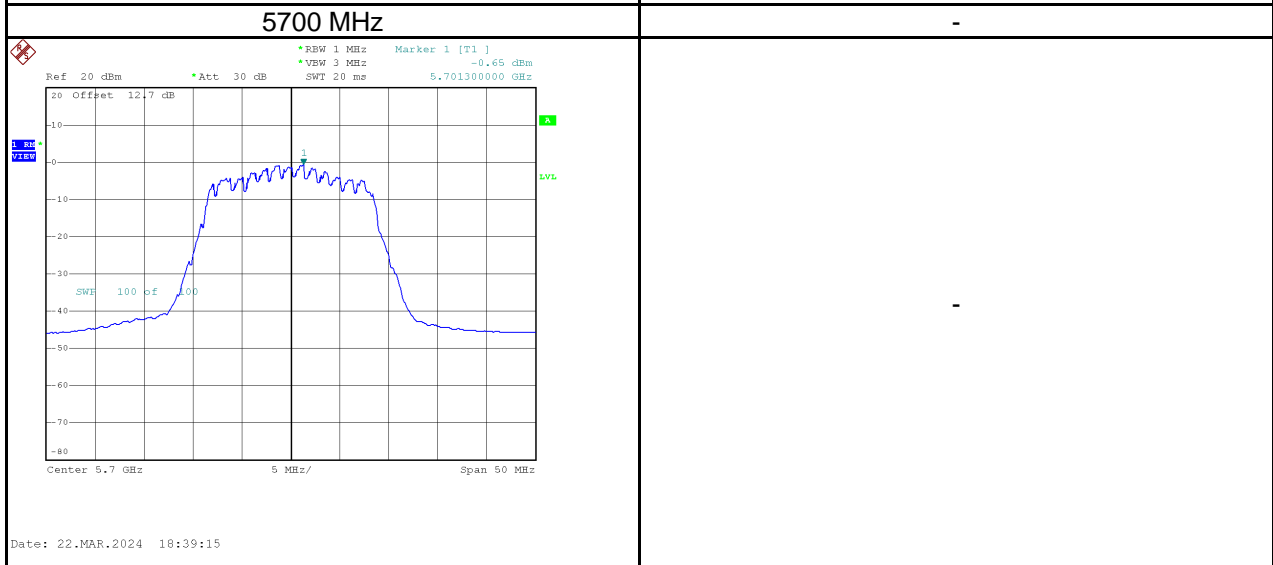
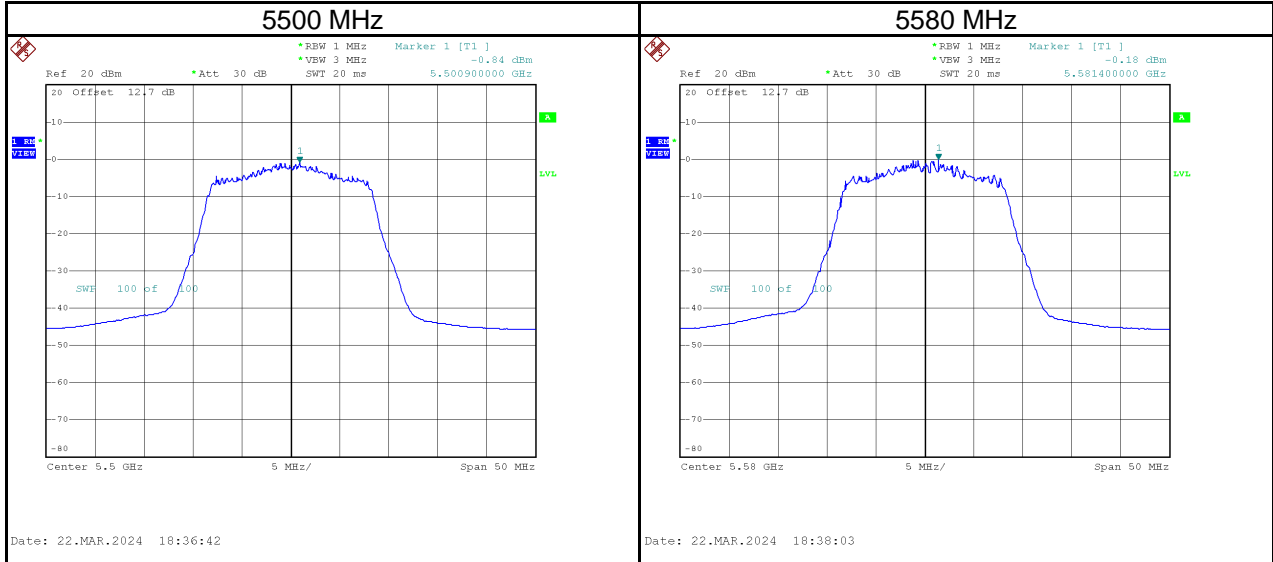

Test Frequency (MHz)	Power Density (dBm/100 kHz)	Power Density (dBm/500 kHz)	Duty Factor (dB)	Calculated Power Density (dBm/500 kHz)	Maximum Limit (dBm/500 kHz)	Result
5745	-2.68	4.31	0.34	4.64	30.00	Pass
5785	-2.95	4.04	0.34	4.37	30.00	Pass
5825	-3.60	3.39	0.34	3.72	30.00	Pass

NOTE: $PSD_{dBm/500\text{ kHz}} = PSD_{dBm/100\text{ kHz}} + 10 \times \log_{10}(500\text{ kHz} / 100\text{ kHz})$

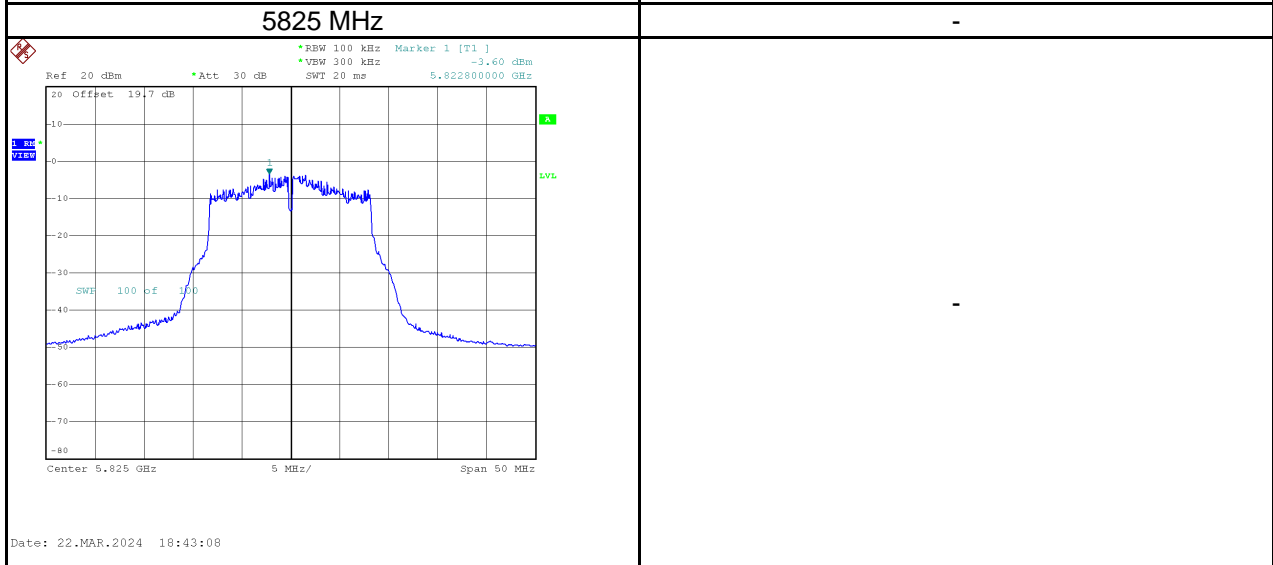
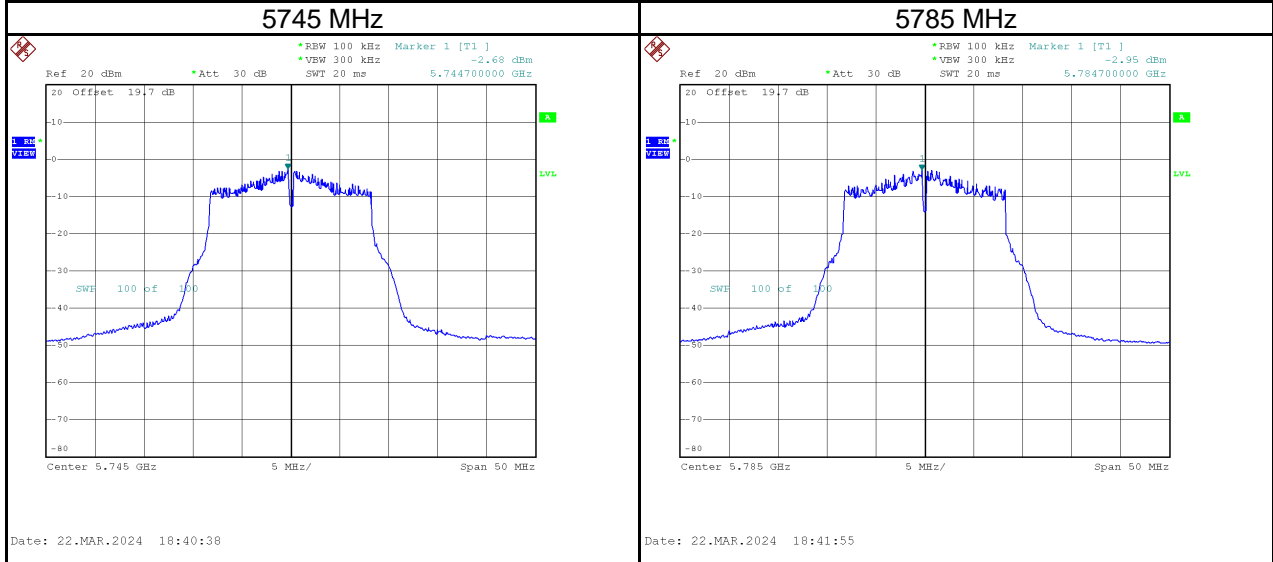

Test Mode	IEEE 802.11n (HT20)
-----------	---------------------

Test Frequency (MHz)	Power Density (dBm/MHz)	Duty Factor (dB)	Calculated Power Density (dBm/MHz)	Maximum Limit (dBm/MHz)	Result
5180	-1.69	0.38	-1.31	17.00	Pass
5200	-0.94	0.38	-0.56	17.00	Pass
5240	-0.74	0.38	-0.36	17.00	Pass

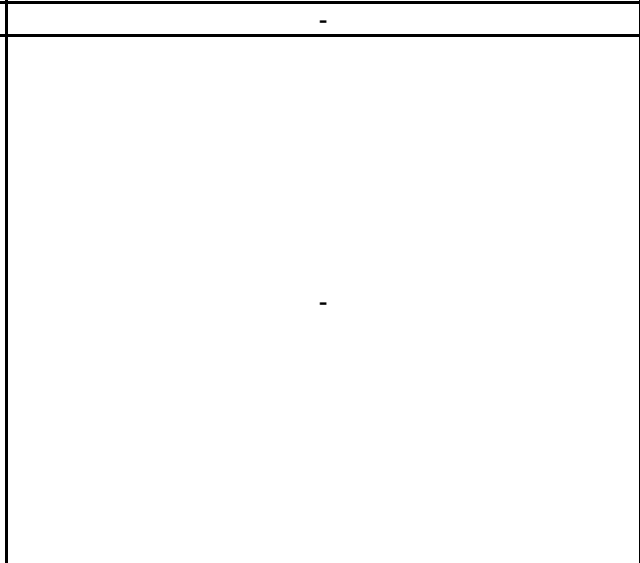
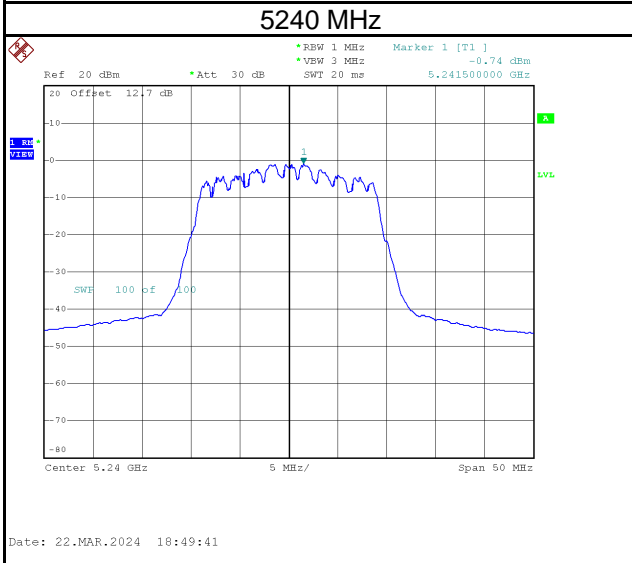
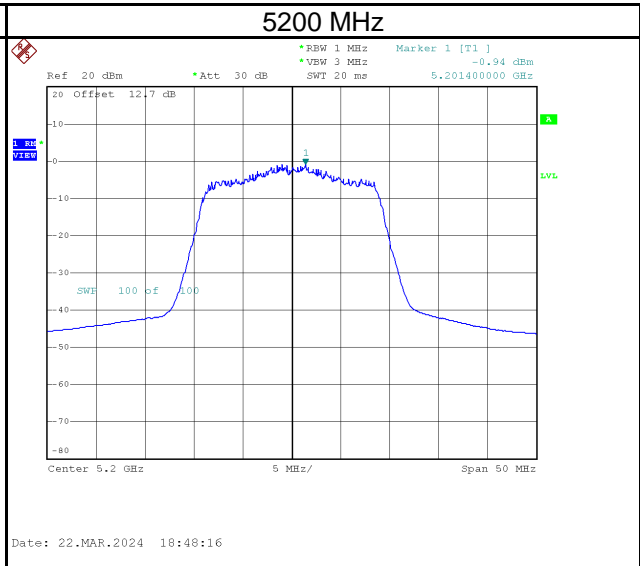
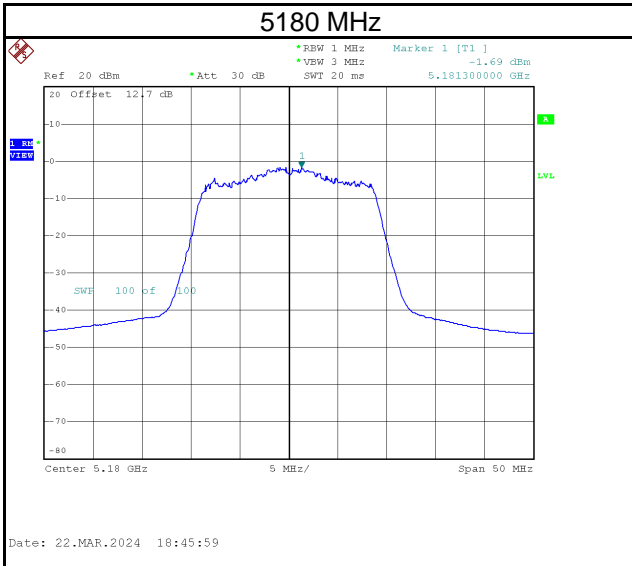

Test Frequency (MHz)	Power Density (dBm/MHz)	Duty Factor (dB)	Calculated Power Density (dBm/MHz)	Maximum Limit (dBm/MHz)	Result
5260	-0.90	0.38	-0.52	11.00	Pass
5300	-1.06	0.38	-0.68	11.00	Pass
5320	-0.79	0.38	-0.41	11.00	Pass

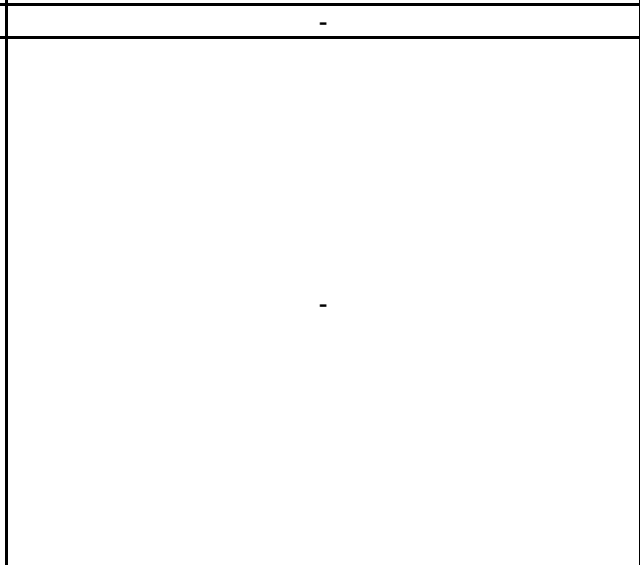
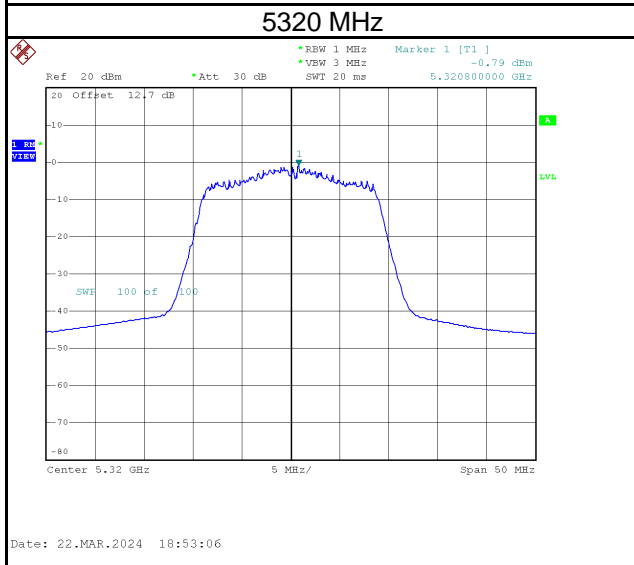
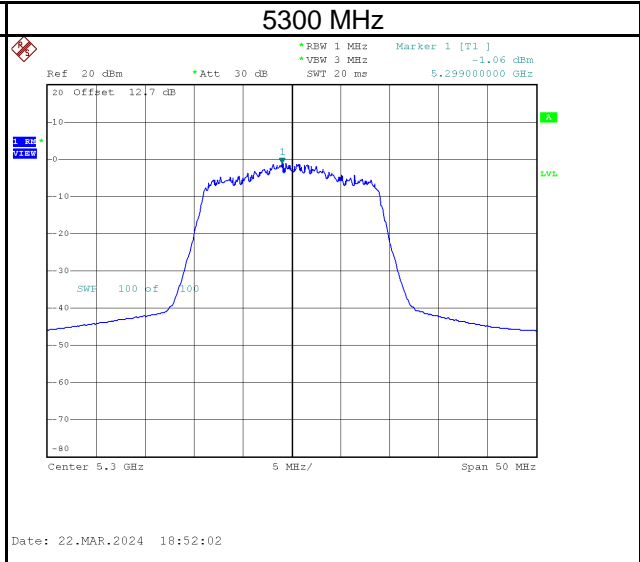
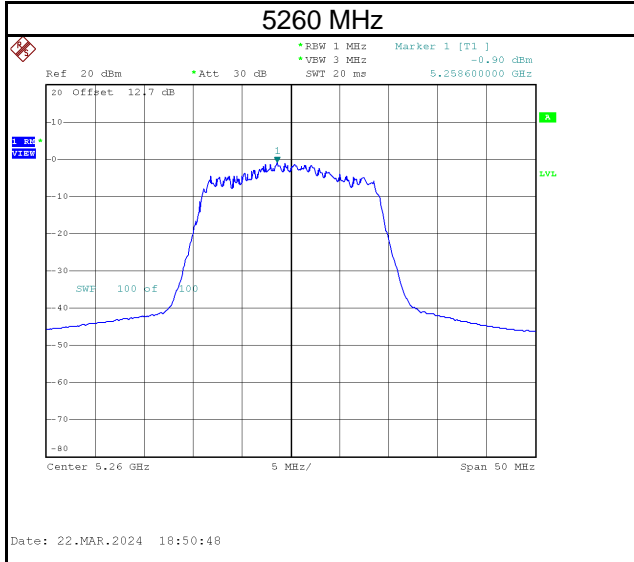

Test Frequency (MHz)	Power Density (dBm/MHz)	Duty Factor (dB)	Calculated Power Density (dBm/MHz)	Maximum Limit (dBm/MHz)	Result
5500	-0.68	0.38	-0.30	11.00	Pass
5580	-0.23	0.38	0.15	11.00	Pass
5700	-1.59	0.38	-1.21	11.00	Pass

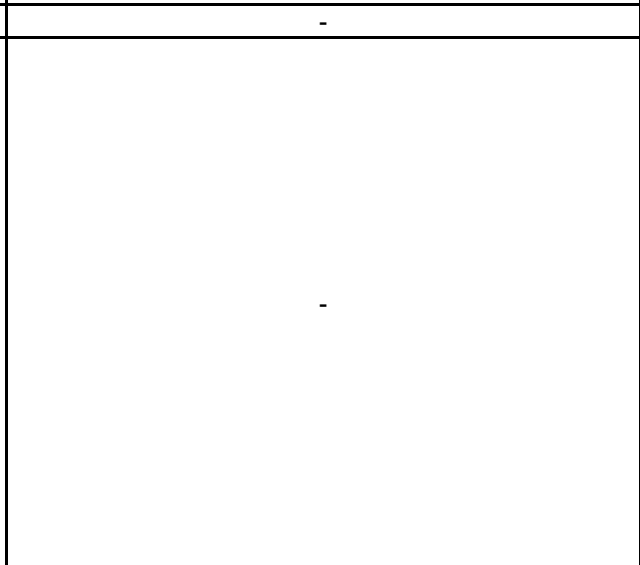
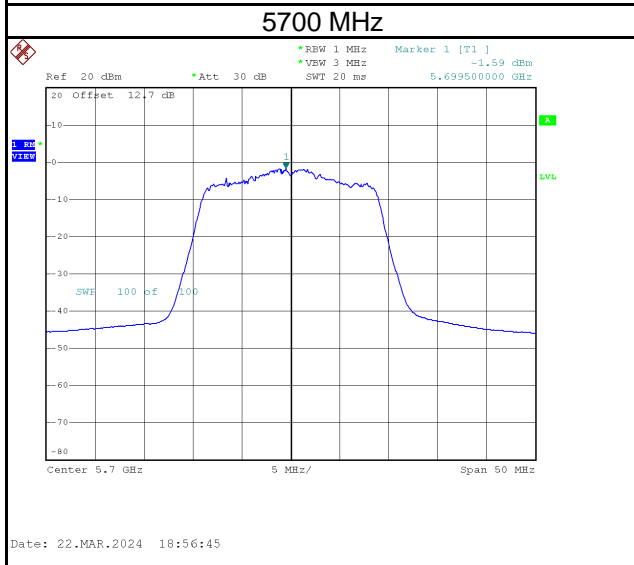
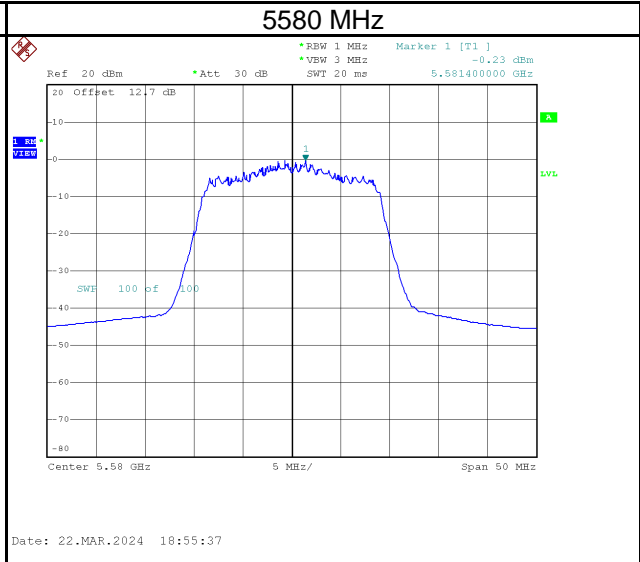
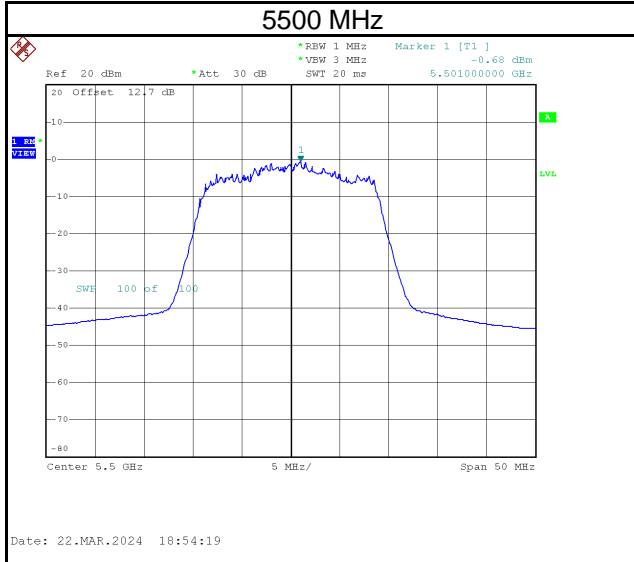

Test Frequency (MHz)	Power Density (dBm/100 kHz)	Power Density (dBm/500 kHz)	Duty Factor (dB)	Calculated Power Density (dBm/500 kHz)	Maximum Limit (dBm/500 kHz)	Result
5745	-3.23	3.76	0.38	4.14	30.00	Pass
5785	-3.77	3.22	0.38	3.60	30.00	Pass
5825	-3.11	3.88	0.38	4.26	30.00	Pass

NOTE: $PSD_{dBm/500\text{ kHz}} = PSD_{dBm/100\text{ kHz}} + 10 \times \log_{10}(500\text{ kHz} / 100\text{ kHz})$

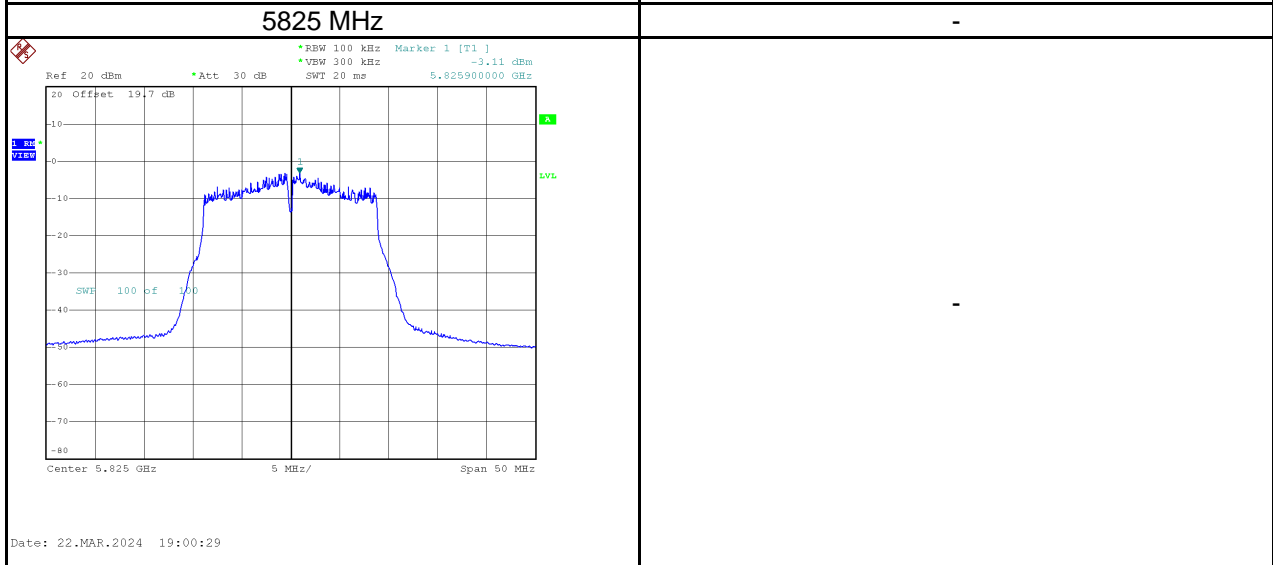
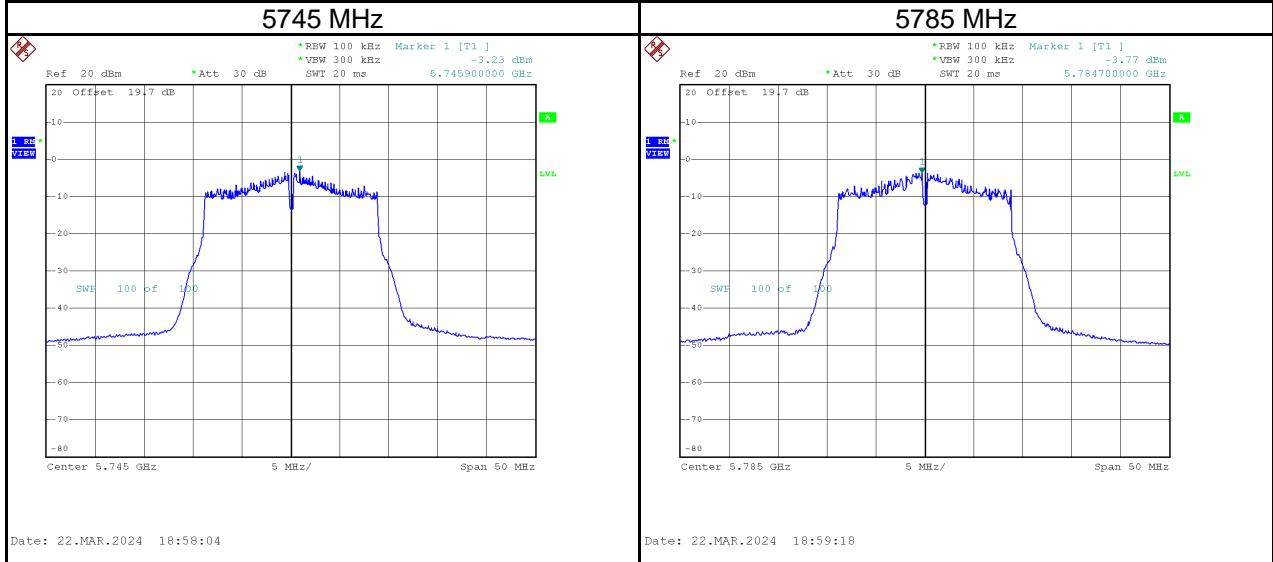

Test Mode	IEEE 802.11n (HT40)
-----------	---------------------

Test Frequency (MHz)	Power Density (dBm/MHz)	Duty Factor (dB)	Calculated Power Density (dBm/MHz)	Maximum Limit (dBm/MHz)	Result
5190	-6.27	0.89	-5.38	17.00	Pass
5230	-5.03	0.89	-4.14	17.00	Pass

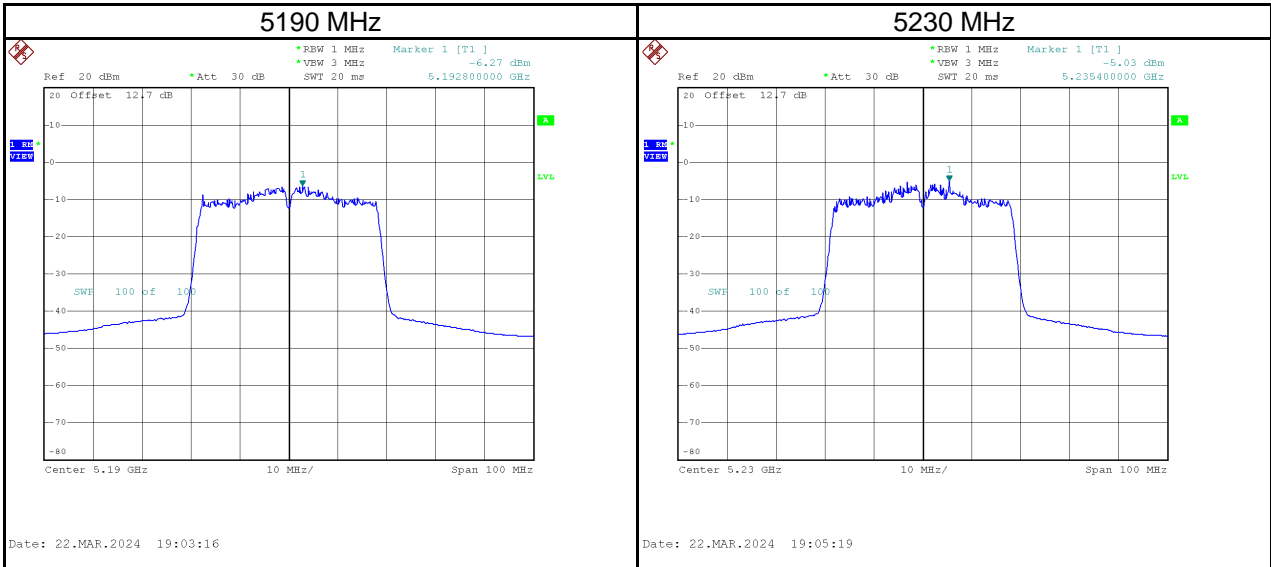

Test Frequency (MHz)	Power Density (dBm/MHz)	Duty Factor (dB)	Calculated Power Density (dBm/MHz)	Maximum Limit (dBm/MHz)	Result
5270	-6.10	0.89	-5.21	11.00	Pass
5310	-4.38	0.89	-3.49	11.00	Pass

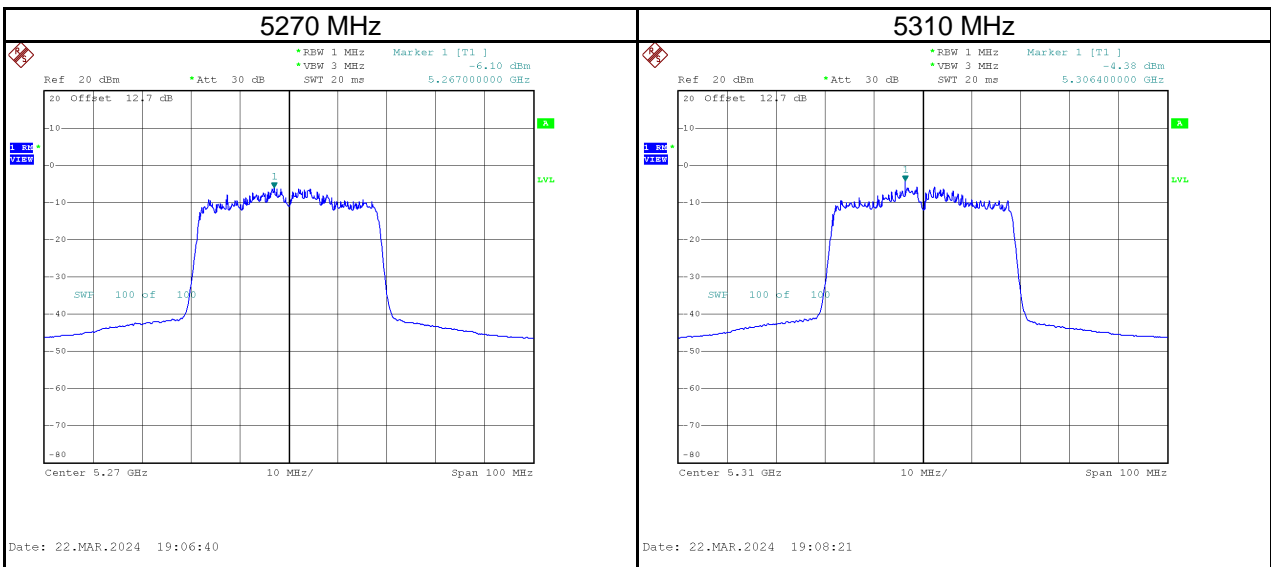

Test Frequency (MHz)	Power Density (dBm/MHz)	Duty Factor (dB)	Calculated Power Density (dBm/MHz)	Maximum Limit (dBm/MHz)	Result
5510	-5.57	0.89	-4.68	11.00	Pass
5550	-5.61	0.89	-4.72	11.00	Pass
5670	-6.09	0.89	-5.20	11.00	Pass

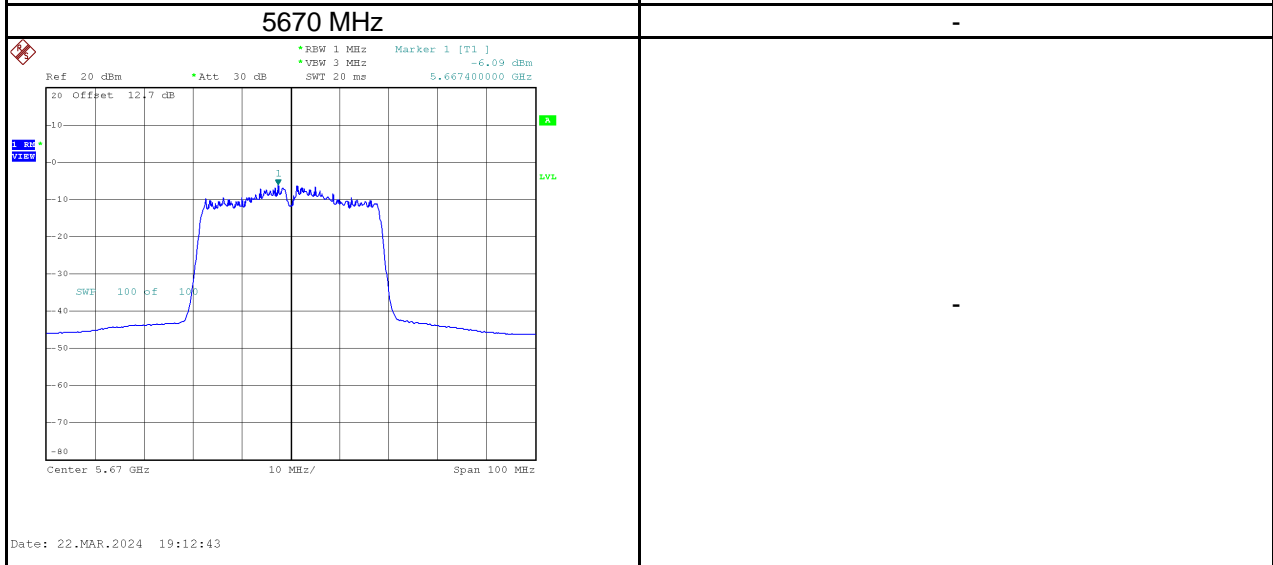
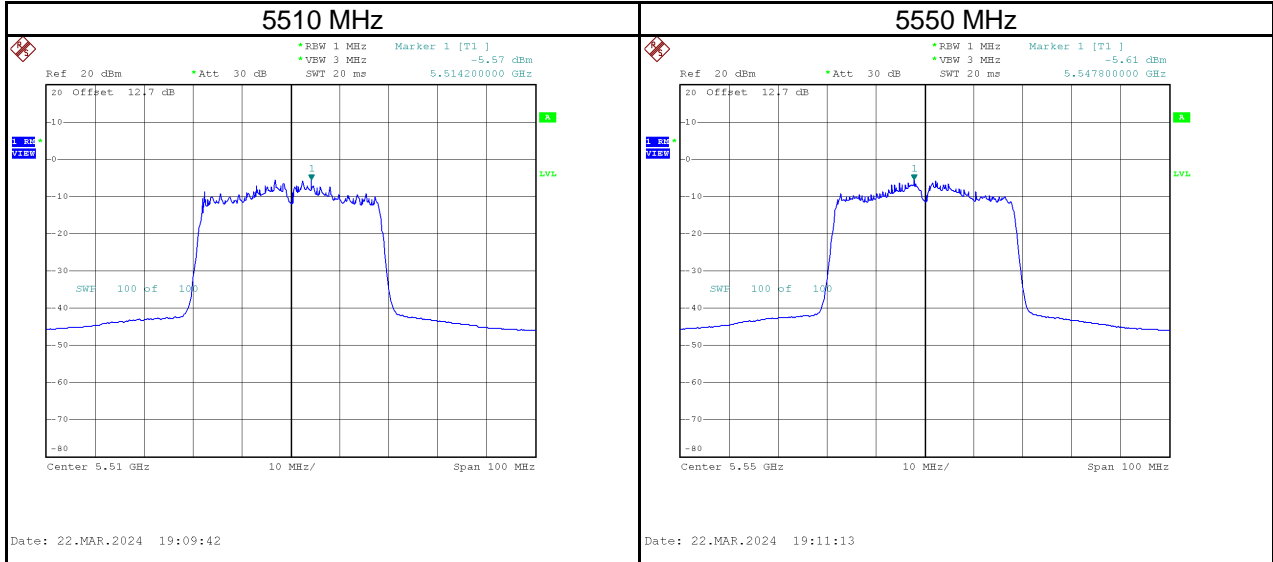

Test Frequency (MHz)	Power Density (dBm/100 kHz)	Power Density (dBm/500 kHz)	Duty Factor (dB)	Calculated Power Density (dBm/500 kHz)	Maximum Limit (dBm/500 kHz)	Result
5755	-7.62	-0.63	0.89	0.26	30.00	Pass
5795	-8.46	-1.47	0.89	-0.58	30.00	Pass

NOTE: $PSD_{dBm/500\text{ kHz}} = PSD_{dBm/100\text{ kHz}} + 10 \times \log_{10}(500\text{ kHz} / 100\text{ kHz})$

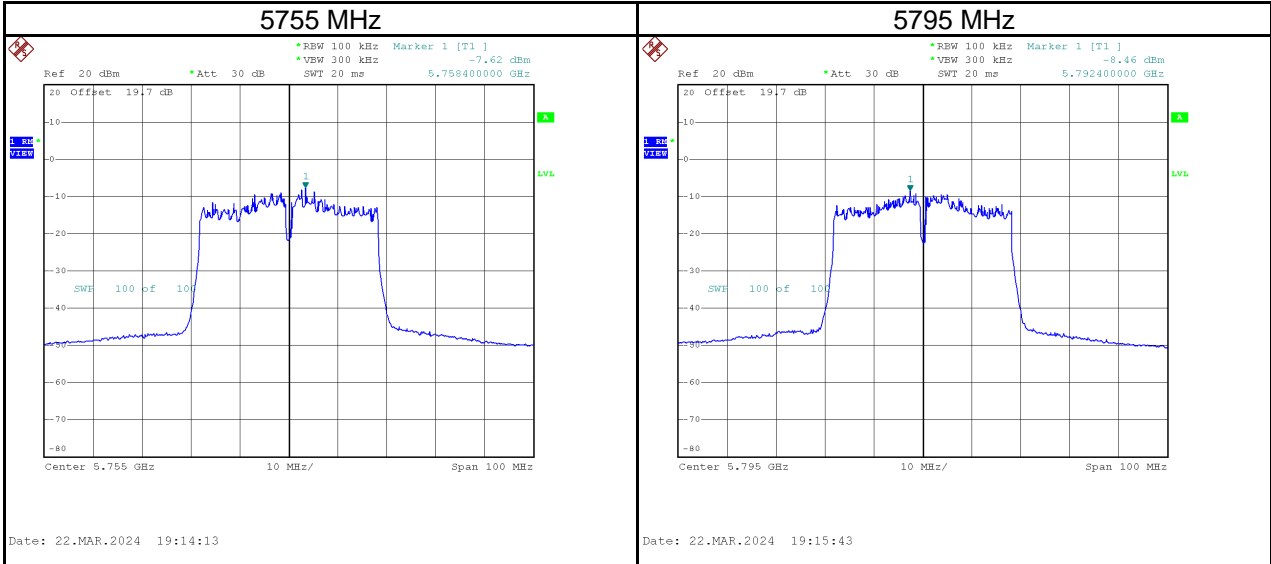

Test Mode	IEEE 802.11ac (VHT80)
-----------	-----------------------

Test Frequency (MHz)	Power Density (dBm/MHz)	Duty Factor (dB)	Calculated Power Density (dBm/MHz)	Maximum Limit (dBm/MHz)	Result
5210	-12.60	1.68	-10.92	17.00	Pass

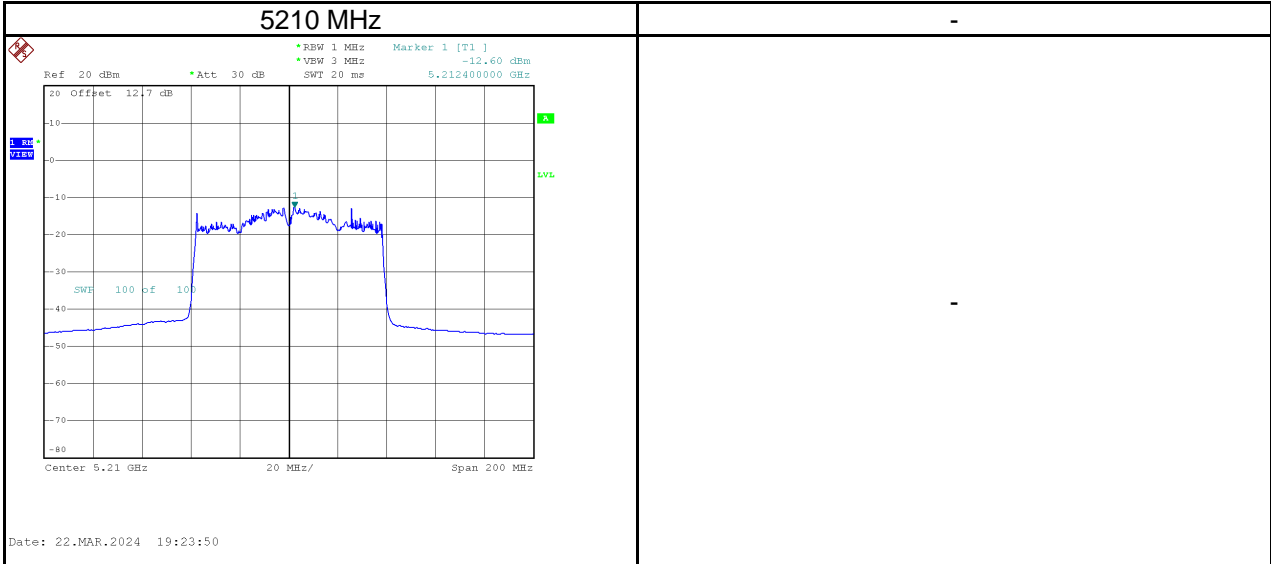

Test Frequency (MHz)	Power Density (dBm/MHz)	Duty Factor (dB)	Calculated Power Density (dBm/MHz)	Maximum Limit (dBm/MHz)	Result
5290	-11.15	1.68	-9.47	11.00	Pass

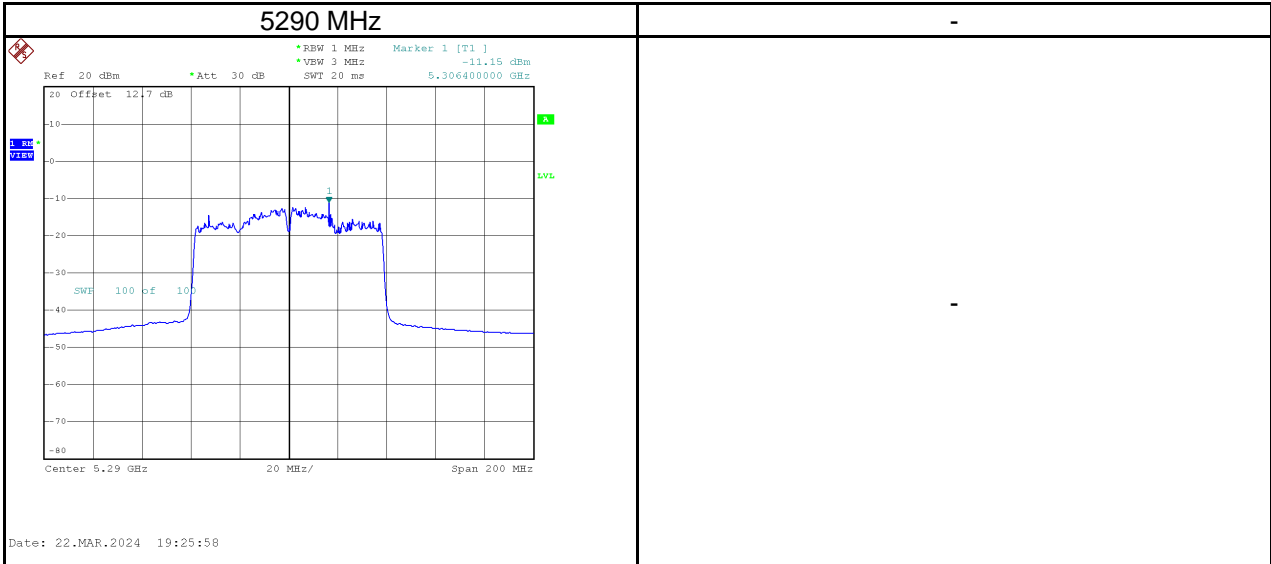

Test Frequency (MHz)	Power Density (dBm/MHz)	Duty Factor (dB)	Calculated Power Density (dBm/MHz)	Maximum Limit (dBm/MHz)	Result
5530	-11.96	1.68	-10.28	11.00	Pass
5610	-12.13	1.68	-10.45	11.00	Pass

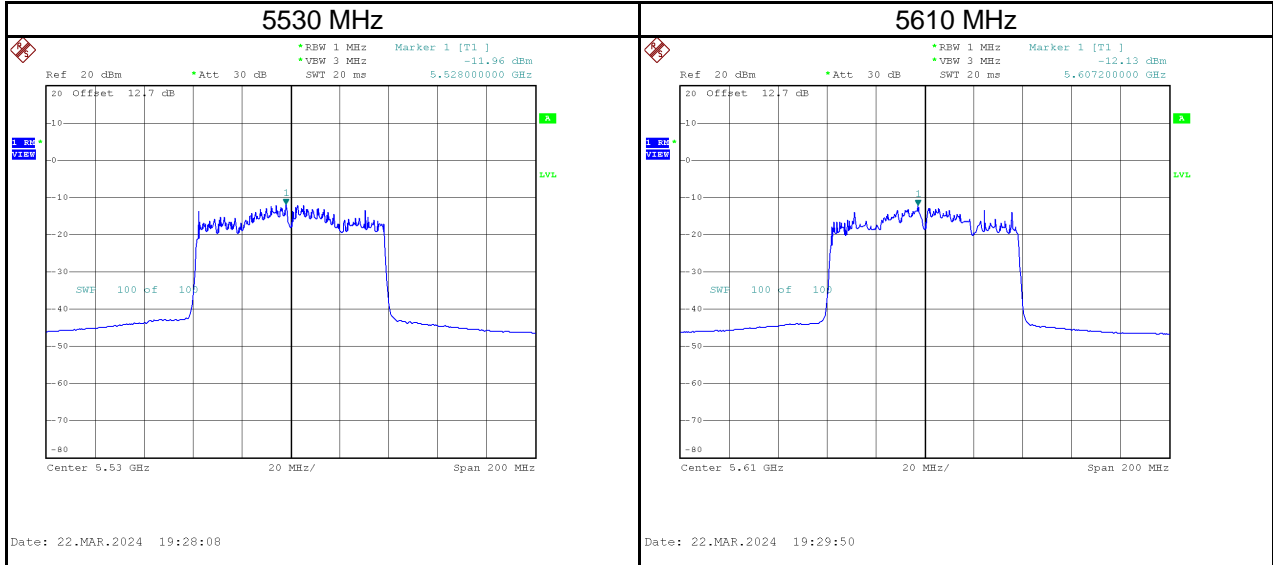

Test Frequency (MHz)	Power Density (dBm/100 kHz)	Power Density (dBm/500 kHz)	Duty Factor (dB)	Calculated Power Density (dBm/500 kHz)	Maximum Limit (dBm/500 kHz)	Result
5775	-14.03	-7.04	1.68	-5.36	30.00	Pass

NOTE: $PSD_{dBm/500\text{ kHz}} = PSD_{dBm/100\text{ kHz}} + 10 \times \log_{10}(500\text{ kHz} / 100\text{ kHz})$

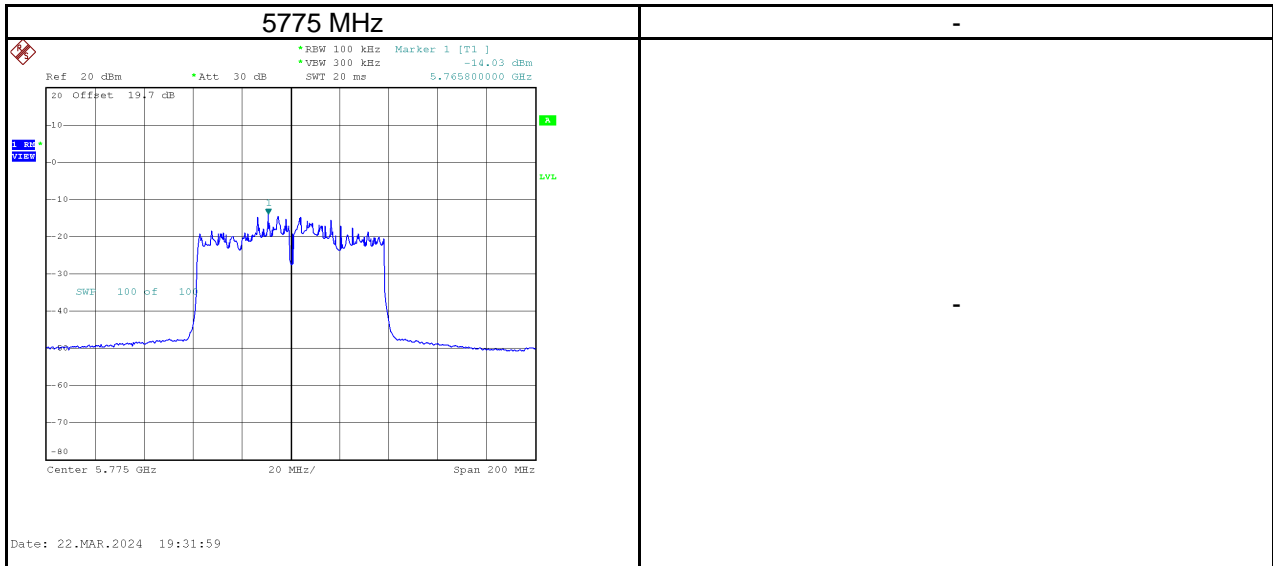

End of Test Report