



GETTING STARTED GUIDE



Cisco Aironet 1800s Network Sensor

First Published: April 5, 2017

- 1** About this Guide
- 2** About the Network Sensor
- 3** Safety Instructions
- 4** Unpacking the 1800s Network Sensor
- 5** Ports and Connectors on the 1800s
- 6** Preparing the AP for Installation
- 6** Installation Overview
- 8** Performing a Pre-Installation Configuration
- 7** Mounting and Powering the Network Sensor
- 8** Configuring the Network Sensor for Wireless Service Assurance
- 8** Configuring the Network Sensor for Wireless Service Assurance
- 12** Checking the Network Sensor LED
- 13** Miscellaneous Usage and Configuration Guidelines
- 10** Related Documentation
- 11** Declarations of Conformity and Regulatory Information

1 About this Guide

This guide provides instructions on how to install and configure your Cisco Aironet 1800s Network Sensor. This guide also provides mounting instructions and limited troubleshooting procedures.

The Cisco Aironet 1800s Network Sensor is referred to as the *network sensor*, or *sensor* in this document.

2 About the Network Sensor

The Cisco Aironet 1800s wireless network sensor is a part of Cisco's Wireless Service Assurance solution. The Wireless Service Assurance platform has three components, namely, Wireless Performance Analytics, Real-time Client Troubleshooting, and Proactive Health Assessment.

The Cisco Aironet 1800s network sensor is an 802.11 a/b/g/n/ac (Wave 2) sensor, with internal antennas, and an Ethernet backhaul. The network sensor can be mounted, in a vertical orientation, on a wall or a desk, and supports 2x2:2 SS MU-MIMO applications. The sensor is capable of connecting to a Wireless LAN Controller via CAPWAP, or, joining an infrastructure Access Point as a client. The sensor can be used to monitor, measure, and troubleshoot overall wired and wireless network performance.

The 1800s wireless network sensor is available as a base unit with these three power accessory modules:

- USB adapter module (AIR-MOD-USB-xx)
- AC adapter module (AIR-MOD-AC-xx)
- PoE/Ethernet module (AIR-MOD-POE-xx)

Network Sensor Model Numbers and Regulatory Domains

The Cisco Aironet 1800s network sensor model has the model number format AIR-AP1800S-x-K9, where the 'x' placeholder represents the regulatory domain. The 'x' can be any one of the supported regulatory domains as listed at:

<http://www.cisco.com/go/aironet/compliance>

Network Sensor Features

A full listing of the network sensor's features and specification are provided in the *Cisco Aironet 1800s Network Sensor Data Sheet*, at the following URL:

([URL to be added at CCO](#))

The features of the 1800s network sensors are as follows:

- The only supported mode of operation is as a network sensor for Wireless Service Assurance.
- Two integrated omnidirectional 2.4 GHz single band and 5 GHz single band antennas. Peak antenna gain is approximately 3 dBi and 5 dBi in 2.4 GHz and 5 GHz bands respectively.
- Radio features supported are:
 - 2.4 GHz and 5 GHz concurrent radios
 - 2 GHz radio with 2TX x 2RX and two spatial streams SU-MIMO
 - 5 GHz radio with 2TX x 2RX 802.11ac Wave 2 capable with two spatial streams SU-MIMO and MU-MIMO
 - 802.11ac based Transmit Beamforming
 - Quality of Service (QoS)
 - Radio Resource Management (RRM)
 - Rogue Detection
 - BandSelect
 - Bluetooth Low Energy 4.0
- Hardware external interfaces:
 - One 10/100/1000 BASE-T (Ethernet) Uplink Interface with inline power capability, Auto-MDIX (automatically support either straight through or crossover cables), and 802.3af/at PoE.
 - RS-232 console interface, using a custom console cable AIR-MOD-UART-xx.
- Depending on the model of the network sensor and the mounting option chosen, it can be powered using:
 - USB power 5V, 1.5A.
 - AC power, from Cisco-supplied AC Adapter, providing 120~240VAC, 50~60Hz power.
 - PoE power from a network device supplying 802.3af Class 0 power or greater. You can use Cisco power injectors AIR-PWRINJ5 (for 802.3af) or AIR-PWRINJ6 (for 802.3at).

For more information on power and mounting options, see XXX.

- Reset button. For information on how to use the Reset button, see [“Using the Reset Button” section on page 25](#).

- One multi-color LED status indicator. See the “[Checking the Network Sensor LED](#)” section on [page 18](#) for information on the colors of the LED status indicator.
- BLE antenna gain is 1 dBi

3 Safety Instructions

Translated versions of the following safety warnings are provided in the translated safety warnings document that is shipped with your network sensor. The translated warnings are also in the *Translated Safety Warnings for Cisco Aironet Network Sensors*, which is available on Cisco.com.



Warning

IMPORTANT SAFETY INSTRUCTIONS

This warning symbol means danger. You are in a situation that could cause bodily injury. Before you work on any equipment, be aware of the hazards involved with electrical circuitry and be familiar with standard practices for preventing accidents. Use the statement number provided at the end of each warning to locate its translation in the translated safety warnings that accompanied this device. Statement 1071

SAVE THESE INSTRUCTIONS



Warning

Read the installation instructions before you connect the system to its power source. Statement 1004



Warning

Installation of the equipment must comply with local and national electrical codes. Statement 1074



Warning

This product relies on the building's installation for short-circuit (overcurrent) protection. Ensure that the protective device is rated not greater than: 20A. Statement 1005



Warning

Do not operate your wireless network device near unshielded blasting caps or in an explosive environment unless the device has been modified to be especially qualified for such use. Statement 245B



Caution

This product and all interconnected equipment must be installed indoors within the same building, including the associated LAN connections as defined by Environment A of the IEEE 802.3af/at Standard.

**Note**

The network sensor is suitable for use in environmental air space in accordance with section 300.22.C of the National Electrical Code and sections 2-128, 12-010(3), and 12-100 of the Canadian Electrical Code, Part 1, C22.1. You should not install the power supply or power injector in air handling spaces.

**Note**

Use only with listed Information Technology Equipment (ITE) equipment. For more information on ITE equipment, refer to article 645 of the latest National Electrical Code (NEC).

4 Unpacking the 1800s Network Sensor

To unpack the network sensor, follow these steps:

-
- Step 1** Unpack and remove the network sensor and the mounting accessories, from the shipping box.
- Step 2** Return any packing material to the shipping container and save it for future use.
- Step 3** Verify that you have received the items listed below. If any item is missing or damaged, contact your Cisco representative or reseller for instructions.
- The network sensor base unit.
 - One of the optional power accessory modules, selected when you ordered the network sensor. These modules be ordered separately also.
-

5 Ports and Connectors on the 1800s

Figure 1 Status LED and Ports Location – Face of the Sensor

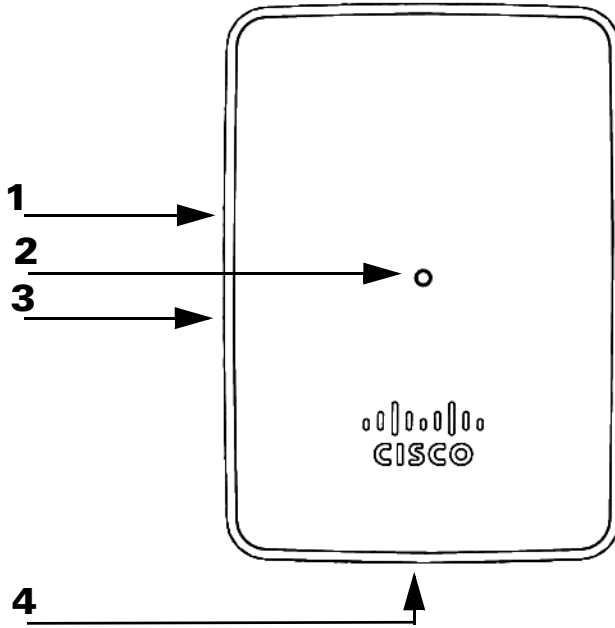

1	Reset button, on the right side of the sensor. For information on how to use the Reset button, see “Using the Reset Button” section on page 25 .
2	Status LED. For more information, see the “Network Sensor Status LED” section on page 23 .
3	Kensington security lock slot, on the right side of the sensor.
4	For the 1800s wireless network sensor having the AIR-MOD-POE-xx PoE/Ethernet module, the base of the sensor has a USB port and the PoE port (Gigabit Ethernet uplink port). For the 1800s wireless network sensor having the AIR-MOD-AC-xx EU-specification AC adapter module, the base of the sensor will have a power on-off switch.

Figure 2 Base of the Network Sensor – With AIR-MOD-POE-xx PoE/Ethernet Module

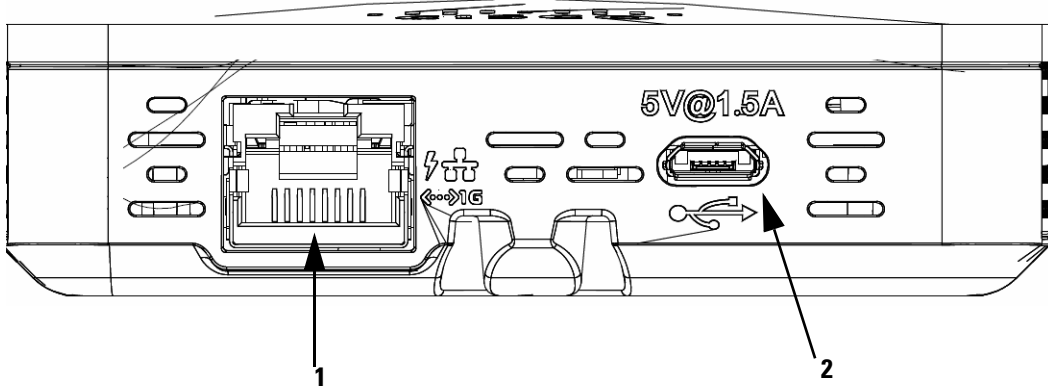

<p>1</p>	<p>10/100/1000 BASE-T (Ethernet) Uplink Interface with inline power capability, Auto-MDIX (automatically support either straight through or crossover cables), and 802.3af/at PoE-In</p>	<p>2</p>	<p>USB port for powering the sensor, using 5V, 1.5A power.</p>
-----------------	--	-----------------	--

6 Installation Overview

Installing the network sensor involves these operations:

- Step 1** [Mounting and Powering the Network Sensor, page 10](#)
- Step 2** [Configuring the Network Sensor for Wireless Service Assurance, page 22](#)
- Step 3** [Configuring the Network Sensor for Wireless Service Assurance, page 22](#)

7 Mounting and Powering the Network Sensor

Cisco Aironet 1800s series network sensors can be mounted in a vertical orientation, on a wall or desk. You can also mount the sensor on an electrical or network box. The mounting and powering options are provided in the following table.

Network Sensor and Powering Accessory Module	Power Supply Option(s)	Mounting Option(s)
1800s network sensor with PoE/Ethernet module AIR-MOD-POE-xx	<ul style="list-style-type: none"> • AC power, using the AC-USB adapter AIR-MOD-USB, supplying 5V DC, 1.5A power. • PoE, 802.3af Class 0 power or greater, from: <ul style="list-style-type: none"> – a network device or power injector. – Cisco power injectors AIR-PWRINJ5 (for 802.3af) or AIR-PWRINJ6 (for 802.3at). 	Vertical mounting on a wall or desk, using AIR-AP-BRACKET-NS. See the “Mounting the Sensor using AIR-AP-BRACKET-NS” section on page 11.
1800s network sensor with USB adapter module AIR-MOD-USB-xx	AC power, using the AC-USB adapter AIR-MOD-USB, supplying 5V DC, 1.5A power.	
1800s network sensor with AC adapter module AIR-MOD-AC-xx	AC power from a wall socket power outlet, through the AC Adapter module, providing 120~240VAC, 50~60Hz power.	The AC adapter module also functions as a mounting cradle, thereby mounting the sensor on a wall socket power outlet. See the “Mounting the Sensor using AIR-MOD-AC-xx Cradle” section on page 15.

Mounting the Sensor using AIR-AP-BRACKET-NS

The Cisco Aironet 1800s wireless sensor can be mounted, in a vertical orientation, on a wall or desk, to a height of 3 feet, using the wall-mount bracket AIR-AP-BRACKET-NS.

To mount the sensor, follow these instructions:

-
- Step 1** Identify the location for mounting the sensor.
 - Step 2** Use the wall-mount bracket AIR-AP-BRACKET-NS, as a template to mark the two screw-hole locations for fastening the bracket to the wall or desk.
 - Step 3** At the marked locations, drill a hole into the wall or desk.
 - Step 4** Fasten the AIR-AP-BRACKET-NS to the wall using two 18mm screws.
 - Step 5** Hold the back of the sensor against the wall, above the bracket, and then slide the sensor down onto the bracket, till it clicks into place. The hooks on the bracket will click into the recesses on the back of the sensor.
 - Step 6** Proceed with connecting the data and power cables.
-

The sensor can be powered using:

- AC power, using the AC-USB adapter AIR-MOD-USB, supplying 5V DC, 1.5A power.
- PoE, 802.3af Class 0 power or greater, from:
 - a network device or power injector.
 - Cisco power injectors AIR-PWRINJ5 (for 802.3af) or AIR-PWRINJ6 (for 802.3at).

The PoE and USB ports are located on the base of the sensor. When both AC power and PoE power is available, the PoE power takes precedence.

Figure 3 *Wall and Desk Mounting Bracket AIR-AP-BRACKET-NS*

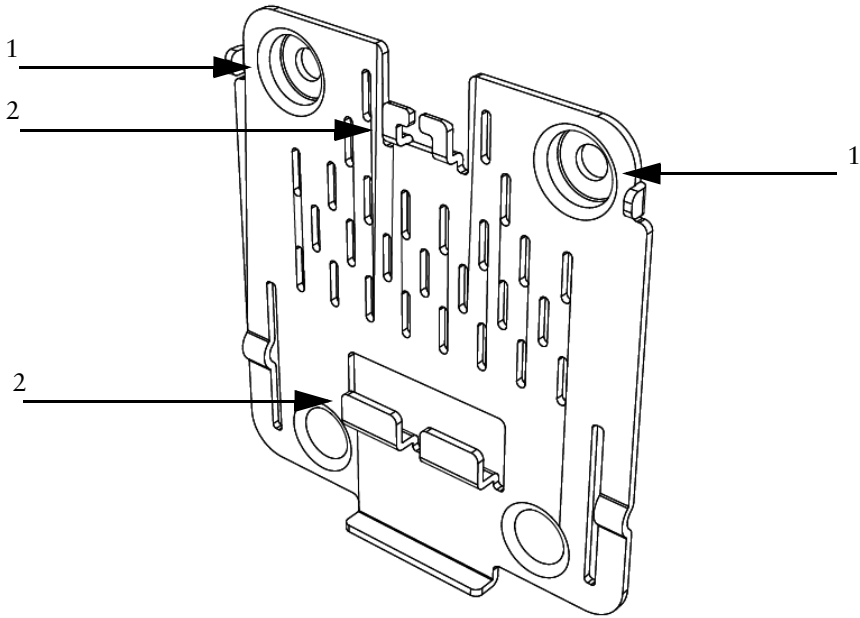

1	Screw holes for fastening the bracket to the wall or desk.	2	Hooks which click into the recesses on the back the sensor, for mounting the sensor on the bracket.
----------	--	----------	---

Figure 4 Back of the Sensor – With PoE/Ethernet Module AIR-MOD-POE-xx

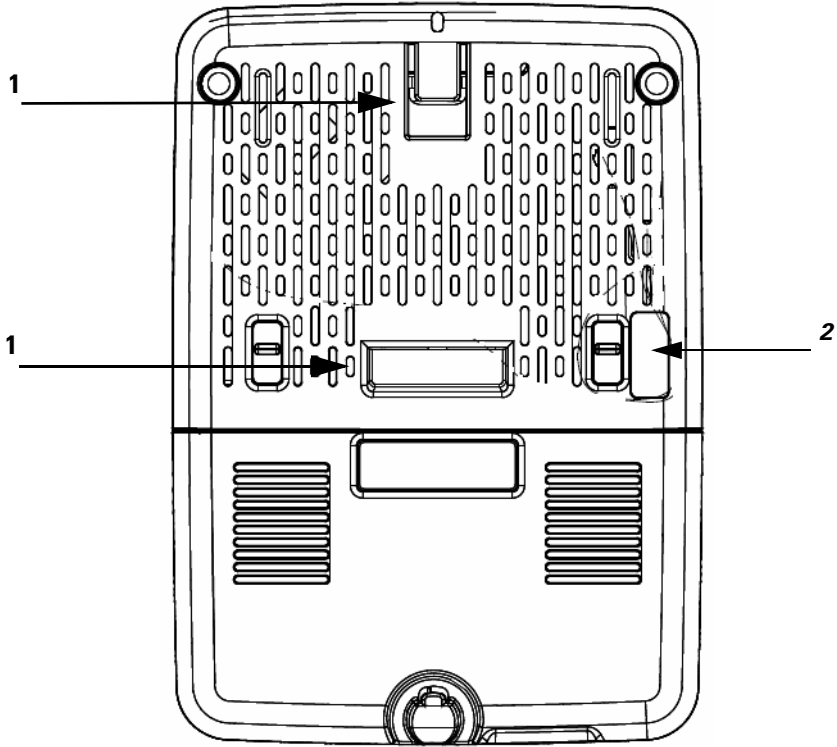

<p>1</p>	<p>Recesses on the back of the sensor into which the hooks on the wall-mount bracket slide and click into place.</p>	<p>2</p>	<p>RS-232 console interface port, hidden under a mylar label. You need to use the custom console cable AIR-MOD-UART-xx.</p>
-----------------	--	-----------------	---

Figure 5 Back of the Sensor – With USB adapter module AIR-MOD-USB-xx

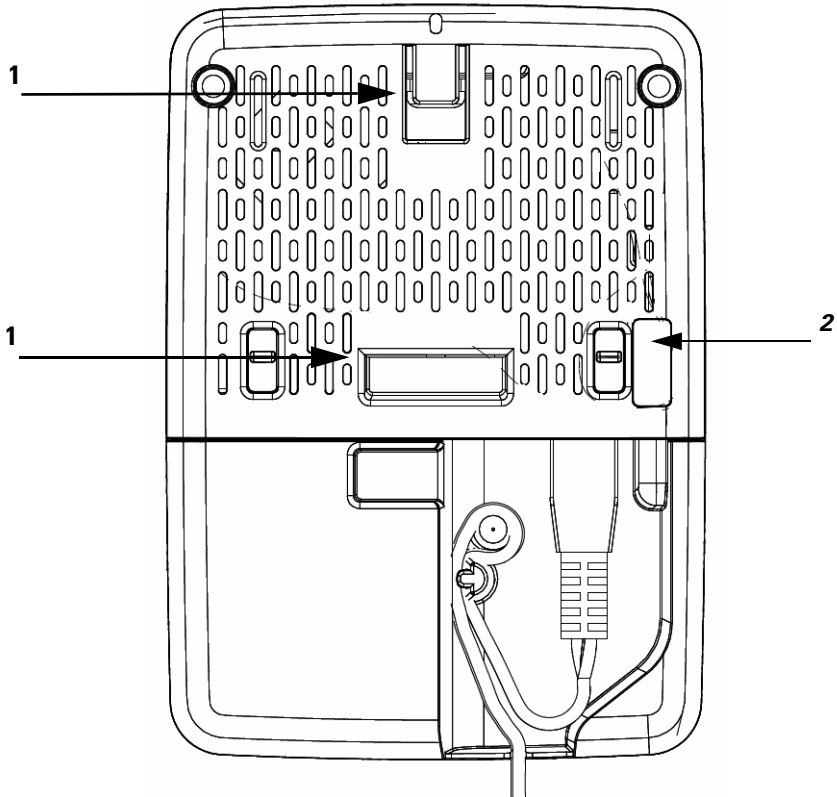

1	Recesses on the back of the sensor into which the hooks on the wall-mount bracket slide and click into place.	2	RS-232 console interface port, hidden under a mylar label. You need to use the custom console cable AIR-MOD-UART-xx.
----------	---	----------	--

Mounting the Sensor using AIR-MOD-AC-xx Cradle

The AIR-MOD-AC-xx AC adapter module also functions as a mounting cradle, using which you can plug-in (and thereby, mount) the sensor into a wall socket power outlet. You can additionally secure the sensor by fastening the security wire to the wall or desk.

Figure 6 Back of the Sensor – With AC Adapter Module AIR-MOD-AC-xx

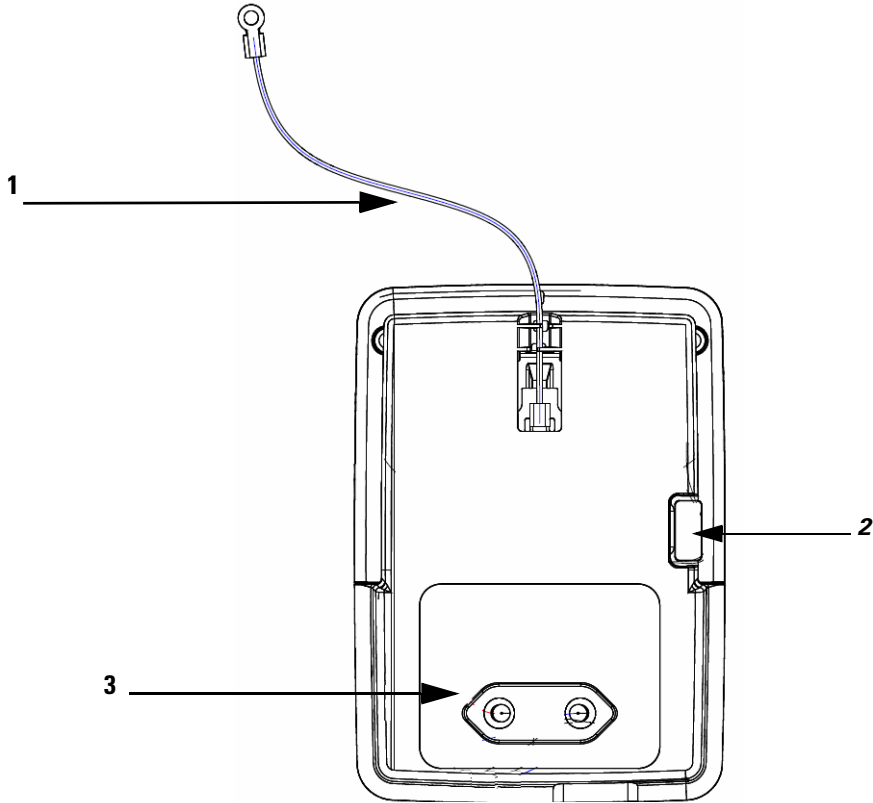

1	Security wire which can be used to secure the sensor by fastening it to the wall.	EU-specification AC adapter module AIR-MOD-AC-xx.
2	RS-232 console interface port, hidden under a mylar label. You need to use the custom console cable AIR-MOD-UART-xx.	3 The AC adapter module/cradle provided differs in design according to regional power supply standards. See the “AC Cradle Options for Different Power Supply Standards and Regions” section on page 16.

AC Cradle Options for Different Power Supply Standards and Regions

Figure 7 Sensor with AC Cradle for AU Region



Figure 8 **Sensor with AC Cradle for CN Region**



Figure 9 **Sensor with AC Cradle for EU Region**



Figure 10 Sensor with AC Cradle for SA Region

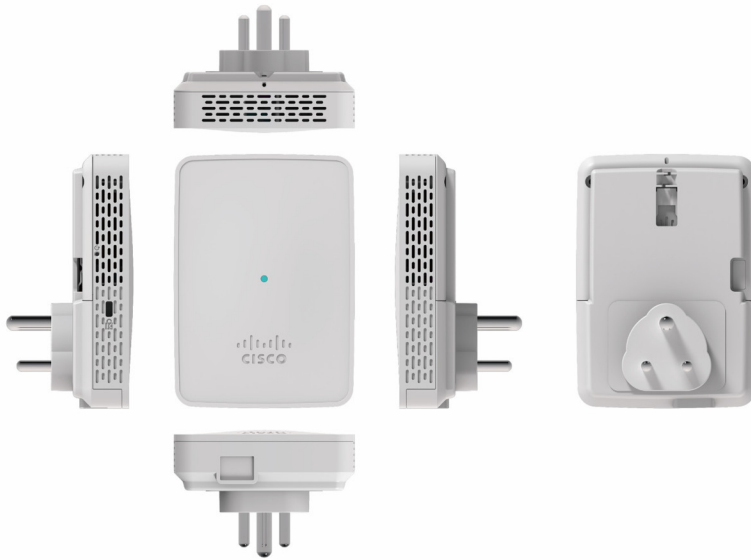

Figure 11 Sensor with AC Cradle for UK Region



Figure 12 Sensor with AC Cradle for US Region



8 Configuring the Network Sensor for Wireless Service Assurance

The Cisco Aironet 1800s wireless network sensors are configured and managed by Cisco wireless LAN controllers. The wireless LAN controller manages network sensors in the same manner as it manages Lightweight Access Points. The controller also:

- Collect stats and data from Network Sensors, Infrastructure APs and Clients and display real time information from the data collected.
- Interfaces with Cisco Cloud Service to send the collected data at regular intervals, to enable the cloud service to display historical information about the wireless network health.

Each network sensor establishes a management and control connection to a Wireless LAN Controller over the intermediate Ipv4/Ipv6 network.

The wireless LAN controller operates as a control center that determines the current task for each network sensor. In addition to configuring network sensors, the controller also collects, aggregates, parses, and presents statistics and results returned from each network sensor.

The wireless LAN controller uses the data from the sensor for basic connectivity troubleshooting, RF performance troubleshooting, and Wireless QoE troubleshooting. The controller also periodically sends wireless network information to the Cisco Cloud Service's Performance Analytics function. The cloud-based Network Assurance Collector collects historical network assurance data, which is scheduled by the controller and collected by the network sensors.

For information on configuring the network sensor and on the role of the wireless LAN controller in Wireless Service Assurance, see the following guide:

[\(To be added at CCO/FCS\)](#)

For more information on the role of the Cisco Cloud Service in Wireless Service Assurance, see the following guide:

[\(To be added at CCO/FCS\)](#)

9 Troubleshooting and Resetting the Network Sensor

Network Sensor Status LED



Note It is expected that there will be small variations in the LED color intensity and hue from unit to unit. This is within the normal range of the LED manufacturer’s specifications and is not a defect.

The network sensor status LED indicates various conditions which are described in [Table 1](#).

Table 1 *LED Status Indications*

Message Type	LED State	Message Meaning
Boot loader status sequence	Blinking Green	DRAM memory test in progress
		DRAM memory test OK
		Board initialization in progress
		Initializing FLASH file system
		FLASH memory test OK
		Initializing Ethernet
		Ethernet OK
		Starting the operating system of the sensor
Initialization successful		
Association status	Chirping Green	Normal operating condition, but no wireless client associated
	Green	Normal operating condition with at least one wireless client association
Operating status	Blinking Amber	Software upgrade is in progress.
	Cycling through Green, Red, and Amber	Discovery/join process is in progress.
	Rapidly cycling through Red, Green, Amber, and off.	Access point location command invoked from controller web interface.
	Blinking Red	Ethernet link is not operational.

Table 1 LED Status Indications (continued)

Message Type	LED State	Message Meaning
Boot loader warnings	Blinking Amber	Configuration recovery in progress (Reset button pushed for 2 to 3 seconds)
	Red	Ethernet failure or image recovery (Reset button pushed for 20 to 30 seconds)
	Blinking Green	Image recovery in progress (Reset button released)
Boot loader errors	Red	DRAM memory test failure
	Blinking Red and Amber	FLASH file system failure
	Blinking Red and off	One of the following: <ul style="list-style-type: none"> • Environment variable failure • Bad MAC address • Ethernet failure during image recovery • Boot environment failure • No Cisco image file • Boot failure
Cisco Network Sensor Operating System errors	Red	Software failure; try disconnecting and reconnecting unit power
	Cycling through Red, Green, Amber and off.	General warning; insufficient inline power

Ethernet Port LEDs

The Ethernet port has two LEDs for showing Link (Green) and Activity (Amber) statuses. They are integrated on the RJ45 connector. For a description of the statuses they indicate, see the following table.

	10M Link	10M Active	100M Link	100M Active	1000M Link	1000M Active
Link (Green) LED State	Off	Off	Off	Off	On	On
Activity (Amber) LED State	On	Blinking	On	Blinking	On	Blinking

Using the Reset Button

Using the Reset button (see [Figure 2](#)) you can:

- Reset the network sensor to its default factory-shipped configuration.
- Clear the network sensor internal storage, including all configuration files and the regulatory domain configuration.

To use the Reset button, press, and keep pressed, the Reset button on the network sensor during the network sensor boot cycle. Wait until the status LED changes to Amber. Then:

- To reset the network sensor to the default factory-shipped configuration, keep the Reset button pressed for less than 20 seconds. The network sensor configuration files are cleared.
This resets all configuration settings to factory defaults, including passwords, encryption keys, the IP address, and the SSID.
- To clear the network sensor internal storage, including all configuration files and the regulatory domain configuration, keep the Reset button pressed for more than 20 seconds, but less than 60 seconds.

The network sensor status LED changes from Amber to Red, and all the files in the network sensor storage directory are cleared.

If you keep the Reset button pressed for more than 60 seconds, the Reset button is assumed faulty and no changes are made.

10 Related Documentation

All user documentation for the Cisco Aironet 1800s series network sensor is available at the following URL:

[\(To be added at CCO/FCS\)](#)

For detailed information and guidelines for configuring and deploying your network sensor in a wireless network, see the *Cisco Wireless LAN Controller Configuration Guide*, at the following URL:

[\(To be added at CCO/FCS\)](#)

11 Declarations of Conformity and Regulatory Information

This section provides declarations of conformity and regulatory information for the Cisco Aironet 1800s Network Sensor. You can find additional information at this URL:

www.cisco.com/go/aironet/compliance

Manufacturers Federal Communication Commission Declaration of Conformity Statement



Network Sensor Models

AIR-AP1800S-B-K9

Certification Number

LDK102108

Manufacturer:

Cisco Systems, Inc.
170 West Tasman Drive
San Jose, CA 95134-1706
USA

This device complies with Part 15 rules. Operation is subject to the following two conditions:

1. This device may not cause harmful interference, and
2. This device must accept any interference received, including interference that may cause undesired operation.

This equipment has been tested and found to comply with the limits of a Class B digital device, pursuant to Part 15 of the FCC Rules. These limits are designed to provide reasonable protection against harmful interference when the equipment is operated in a residential environment. This equipment generates, uses, and radiates radio frequency energy, and if not installed and used in accordance with the instructions, may cause harmful interference. However, there is no guarantee that

interference will not occur. If this equipment does cause interference to radio or television reception, which can be determined by turning the equipment off and on, the user is encouraged to correct the interference by one of the following measures:

- Reorient or relocate the receiving antenna.
- Increase separation between the equipment and receiver.
- Connect the equipment to an outlet on a circuit different from which the receiver is connected.
- Consult the dealer or an experienced radio/TV technician.



Caution

The Part 15 radio device operates on a non-interference basis with other devices operating at this frequency when using the integrated antennas. Any changes or modification to the product not expressly approved by Cisco could void the user's authority to operate this device.

VCCI Statement for Japan

Warning

This is a Class B product based on the standard of the Voluntary Control Council for Interference from Information Technology Equipment (VCCI). If this is used near a radio or television receiver in a domestic environment, it may cause radio interference. Install and use the equipment according to the instruction manual.

警告 この装置は、クラスB情報技術装置です。この装置は、家庭環境で使用することを目的としていますが、この装置がラジオやテレビジョン受信機に近接して使用されると、受信障害を引き起こすことがあります。
取扱説明書に従って正しい取り扱いをして下さい。

VCCI-B

Guidelines for Operating Cisco Aironet Network Sensors in Japan

This section provides guidelines for avoiding interference when operating Cisco Aironet network sensors in Japan. These guidelines are provided in both Japanese and English.

Japanese Translation

この機器の使用周波数帯では、電子レンジ等の産業・科学・医療用機器のほか工場の製造ライン等で使用されている移動体識別用の構内無線局（免許を要する無線局）及び特定小電力無線局（免許を要しない無線局）が運用されています。

- 1 この機器を使用する前に、近くで移動体識別用の構内無線局及び特定小電力無線局が運用されていないことを確認して下さい。
- 2 万一、この機器から移動体識別用の構内無線局に対して電波干渉の事例が発生した場合には、速やかに使用周波数を変更するか又は電波の発射を停止した上、下記連絡先にご連絡頂き、混信回避のための処置等(例えば、パーティションの設置など)についてご相談して下さい。
- 3 その他、この機器から移動体識別用の特定小電力無線局に対して電波干渉の事例が発生した場合など何かお困りのことが起きたときは、次の連絡先へお問い合わせ下さい。

連絡先 : 03-6434-6500

208697

English Translation

This equipment operates in the same frequency bandwidth as industrial, scientific, and medical devices such as microwave ovens and mobile object identification (RF-ID) systems (licensed premises radio stations and unlicensed specified low-power radio stations) used in factory production lines.

1. Before using this equipment, make sure that no premises radio stations or specified low-power radio stations of RF-ID are used in the vicinity.
2. If this equipment causes RF interference to a premises radio station of RF-ID, promptly change the frequency or stop using the device; contact the number below and ask for recommendations on avoiding radio interference, such as setting partitions.
3. If this equipment causes RF interference to a specified low-power radio station of RF-ID, contact the number below.

Contact Number: 03-6434-6500

Statement 371—Power Cable and AC Adapter

接続ケーブル、電源コード、ACアダプタ、バッテリーなどの部品は、必ず添付品または指定品をご使用ください。添付品・指定品以外の部品をご使用になると故障や動作不良、火災の原因となります。また、電気用品安全法により、当該法の認定（PSEとコードに表記）でなくUL認定（ULまたはCSAマークがコードに表記）の電源ケーブルは弊社が指定する製品以外の電気機器には使用できないためご注意ください。

English Translation

When installing the product, please use the provided or designated connection cables/power cables/AC adaptors. Using any other cables/adaptors could cause a malfunction or a fire. Electrical Appliance and Material Safety Law prohibits the use of UL-certified cables (that have the “UL” shown on the code) for any other electrical devices than products designated by CISCO. The use of cables that are certified by Electrical Appliance and Material Safety Law (that have “PSE” shown on the code) is not limited to CISCO-designated products.

Industry Canada

Network Sensor Models

AIR-AP1800S-A-K9

Certification Number

2461B-102108

Canadian Compliance Statement

This device complies with Industry Canada licence-exempt RSS standard(s). Operation is subject to the following two conditions: (1) this device may not cause interference, and (2) this device must accept any interference, including interference that may cause undesired operation of the device. Le présent appareil est conforme aux CNR d'Industrie Canada applicables aux appareils radio exempts de licence. L'exploitation est autorisée aux deux conditions suivantes : (1) l'appareil ne doit pas produire de brouillage, et (2) l'utilisateur de l'appareil doit accepter tout brouillage radioélectrique subi, même si le brouillage est susceptible d'en compromettre le fonctionnement.

Under Industry Canada regulations, this radio transmitter may only operate using an antenna of a type and maximum (or lesser) gain approved for the transmitter by Industry Canada. To reduce potential radio interference to other users, the antenna type and its gain should be so chosen that the equivalent isotropically radiated power (e.i.r.p.) is not more than that necessary for successful communication. Conformément à la réglementation d'Industrie Canada, le présent émetteur radio peut fonctionner avec une antenne d'un type et d'un gain maximal (ou inférieur) approuvé pour l'émetteur par Industrie Canada. Dans le but de réduire les risques de brouillage radioélectrique à l'intention des autres utilisateurs, il faut choisir le type d'antenne et son gain de sorte que la puissance isotrope rayonnée équivalente (p.i.r.e.) ne dépasse pas l'intensité nécessaire à l'établissement d'une communication satisfaisante.

This radio transmitter has been approved by Industry Canada to operate with the antenna types listed below with the maximum permissible gain and required antenna impedance for each antenna type indicated. Antenna types not included in this list, having a gain greater than the maximum gain indicated for that type, are strictly prohibited for use with this device. Le présent émetteur radio a été approuvé par Industrie Canada pour fonctionner avec les types d'antenne énumérés ci-dessous et ayant un gain admissible maximal et l'impédance requise pour chaque type d'antenne. Les types d'antenne non inclus dans cette liste, ou dont le gain est supérieur au gain maximal indiqué, sont strictement interdits pour l'exploitation de l'émetteur.

Antenna Type	Antenna Gain	Antenna Impedance
Dual-band Omni	3/5 dBi	50 ohms

Operation in the band 5150-5250 MHz is only for indoor use to reduce the potential for harmful interference to co-channel mobile satellite systems.

La bande 5 150-5 250 MHz est réservés uniquement pour une utilisation à l'intérieur afin de réduire les risques de brouillage préjudiciable aux systèmes de satellites mobiles utilisant les mêmes canaux.

Users are advised that high-power radars are allocated as primary users (i.e. priority users) of the bands 5250-5350 MHz and 5650-5850 MHz and that these radars could cause interference and/or damage to LE-LAN devices.

Les utilisateurs êtes avisés que les utilisateurs de radars de haute puissance sont désignés utilisateurs principaux (c.-à-d., qu'ils ont la priorité) pour les bandes 5 250-5 350 MHz et 5 650-5 850 MHz et que ces radars pourraient causer du brouillage et/ou des dommages aux dispositifs LAN-EL.

European Community, Switzerland, Norway, Iceland, and Liechtenstein

Network Sensor Models:

AIR-AP1800S-E-K9

Declaration of Conformity with regard to the R&TTE Directive 1999/5/EC & Medical Directive 93/42/EEC

Български [Bulgarian]:	Това оборудване отговаря на съществените изисквания и приложими клаузи на Директива 1999/5/EC.
Česky [Czech]:	Toto zařízení je v souladu se základními požadavky a ostatními odpovídajícími ustanoveními Směrnice 1999/5/EC.
Dansk [Danish]:	Dette udstyr er i overensstemmelse med de væsentlige krav og andre relevante bestemmelser i Direktiv 1999/5/EF.
Deutsch [German]:	Dieses Gerät entspricht den grundlegenden Anforderungen und den weiteren entsprechenden Vorgaben der Richtlinie 1999/5/EU.
Eesti [Estonian]:	See seade vastab direktiivi 1999/5/EÜ olulistele nõuetele ja teistele asjakohastele sätetele.
English:	This equipment is in compliance with the essential requirements and other relevant provisions of Directive 1999/5/EC.
Español [Spanish]:	Este equipo cumple con los requisitos esenciales así como con otras disposiciones de la Directiva 1999/5/CE.
Ελληνική [Greek]:	Αυτός ο εξοπλισμός είναι σε συμμόρφωση με τις ουσιώδεις απαιτήσεις και άλλες σχετικές διατάξεις της Οδηγίας 1999/5/EC.
Français [French]:	Cet appareil est conforme aux exigences essentielles et aux autres dispositions pertinentes de la Directive 1999/5/EC.
Íslenska [Icelandic]:	Þetta tæki er samkvæmt grunnkröfum og öðrum viðeigandi ákvæðum Tilskipunar 1999/5/EC.
Italiano [Italian]:	Questo apparato é conforme ai requisiti essenziali ed agli altri principi sanciti dalla Direttiva 1999/5/CE.
Latviešu [Latvian]:	Šī iekārta atbilst Direktīvas 1999/5/EK būtiskajām prasībām un citiem ar to saistītajiem noteikumiem.

Nederlands [Dutch]:	Dit apparaat voldoet aan de essentiële eisen en andere van toepassing zijnde bepalingen van de Richtlijn 1999/5/EC.
Malti [Maltese]:	Dan l-apparat huwa konformi mal-htigiet essenzjali u l-provedimenti l-oħra rilevanti tad-Direttiva 1999/5/EC.
Magyar [Hungarian]:	Ez a készülék teljesíti az alapvető követelményeket és más 1999/5/EK irányelvben meghatározott vonatkozó rendelkezéseket.
Norsk [Norwegian]:	Dette utstyret er i samsvar med de grunnleggende krav og andre relevante bestemmelser i EU-direktiv 1999/5/EF.
Polski [Polish]:	Urządzenie jest zgodne z ogólnymi wymaganiami oraz szczególnymi warunkami określonymi Dyrektywą UE: 1999/5/EC.
Português [Portuguese]:	Este equipamento está em conformidade com os requisitos essenciais e outras provisões relevantes da Diretiva 1999/5/EC.
Română [Romanian]:	Acest echipament este în conformitate cu cerințele esențiale și cu alte prevederi relevante ale Directivei 1999/5/EC.
Slovensko [Slovenian]:	Ta naprava je skladna z bistvenimi zahtevami in ostalimi relevantnimi pogoji Direktive 1999/5/EC.
Slovensky [Slovak]:	Toto zariadenie je v zhode so základnými požiadavkami a inými príslušnými nariadeniami direktív: 1999/5/EC.
Suomi [Finnish]:	Tämä laite täyttää direktiivin 1999/5/EY olennaiset vaatimukset ja on siinä asetettujen muiden laitetta koskevien määräysten mukainen.
Svenska [Swedish]:	Denna utrustning är i överensstämmelse med de väsentliga kraven och andra relevanta bestämmelser i Direktiv 1999/5/EC.
Türk [Turkish]:	Bu cihaz 1999/5/EC Direktifi'nin temel gereklerine ve ilgili diğer hükümlerine uygundur.

142730

The following standards were applied:

EMC—EN 301.489-1 v1.9.2; EN 301.489-17 v2.2.1

Health & Safety—EN60950-1: 2006; EN 50385: 2002

Radio—EN 300 328 v 1.8.1; EN 301.893 v 1.7.1

The conformity assessment procedure referred to in Article 10.4 and Annex III of Directive 1999/5/EC has been followed.

This device also conforms to the EMC requirements of the Medical Devices Directive 93/42/EEC.



Note This equipment is intended to be used in all EU and EFTA countries. Outdoor use may be restricted to certain frequencies and/or may require a license for operation. For more details, contact Cisco Corporate Compliance.

The product carries the CE Mark:



Declaration of Conformity for RF Exposure

This section contains information on compliance with guidelines related to RF exposure.

Generic Discussion on RF Exposure

The Cisco products are designed to comply with the following national and international standards on Human Exposure to Radio Frequencies:

- US 47 Code of Federal Regulations Part 2 Subpart J
- American National Standards Institute (ANSI) / Institute of Electrical and Electronic Engineers / IEEE C 95.1 (99)
- International Commission on Non Ionizing Radiation Protection (ICNIRP) 98
- Ministry of Health (Canada) Safety Code 6. Limits on Human Exposure to Radio Frequency Fields in the range from 3kHz to 300 GHz
- Australia Radiation Protection Standard

To ensure compliance with various national and international Electromagnetic Field (EMF) standards, the system should only be operated with Cisco approved accessories.

This Device Meets International Guidelines for Exposure to Radio Waves

The 1800s network sensor device includes a radio transmitter and receiver. It is designed not to exceed the limits for exposure to radio waves (radio frequency electromagnetic fields) recommended by international guidelines. The guidelines were developed by an independent scientific organization (ICNIRP) and include a substantial safety margin designed to ensure the safety of all persons, regardless of age and health.

As such the systems are designed to be operated as to avoid contact with the antennas by the end user. It is recommended to set the system in a location where the antennas can remain at least a minimum distance as specified from the user in accordance to the regulatory guidelines which are designed to reduce the overall exposure of the user or operator.

Separation Distance		
MPE	Distance	Limit
0.06 mW/cm ²	20 cm (7.87 inches)	1.00 mW/cm ²

The World Health Organization has stated that present scientific information does not indicate the need for any special precautions for the use of wireless devices. They recommend that if you are interested in further reducing your exposure then you can easily do so by reorienting antennas away from the user or placing the antennas at a greater separation distance than recommended.

This Device Meets FCC Guidelines for Exposure to Radio Waves

The 1800s network sensor device includes a radio transmitter and receiver. It is designed not to exceed the limits for exposure to radio waves (radio frequency electromagnetic fields) as referenced in FCC Part 1.1310. The guidelines are based on IEEE ANSI C 95.1 (92) and include a substantial safety margin designed to ensure the safety of all persons, regardless of age and health.

As such the systems are designed to be operated as to avoid contact with the antennas by the end user. It is recommended to set the system in a location where the antennas can remain at least a minimum distance as specified from the user in accordance to the regulatory guidelines which are designed to reduce the overall exposure of the user or operator.

The device has been tested and found compliant with the applicable regulations as part of the radio certification process.

Separation Distance		
MPE	Distance	Limit
0.60mW/cm ²	20 cm (7.87 inches)	1.00 mW/cm ²

The US Food and Drug Administration has stated that present scientific information does not indicate the need for any special precautions for the use of wireless devices. The FCC recommends that if you are interested in further reducing your exposure then you can easily do so by reorienting antennas away from the user or placing the antennas at a greater separation distance than recommended or lowering the transmitter power output.

This Device Meets the Industry Canada Guidelines for Exposure to Radio Waves

The 1800s network sensor device includes a radio transmitter and receiver. It is designed not to exceed the limits for exposure to radio waves (radio frequency electromagnetic fields) as referenced in Health Canada Safety Code 6. The guidelines include a substantial safety margin designed into the limit to ensure the safety of all persons, regardless of age and health.

As such the systems are designed to be operated as to avoid contact with the antennas by the end user. It is recommended to set the system in a location where the antennas can remain at least a minimum distance as specified from the user in accordance to the regulatory guidelines which are designed to reduce the overall exposure of the user or operator.

Separation Distance			
Frequency	MPE	Distance	Limit
2.4 GHz	0.17 W/m ²	20 cm (7.87 inches)	5.4 W/m ²
5 GHz	0.66 W/m ²		9.2 W/m ²

Health Canada states that present scientific information does not indicate the need for any special precautions for the use of wireless devices. They recommend that if you are interested in further reducing your exposure you can easily do so by reorienting antennas away from the user, placing the antennas at a greater separation distance than recommended, or lowering the transmitter power output.

Cet appareil est conforme aux directives internationales en matière d'exposition aux fréquences radioélectriques

Cet appareil de la gamme 1800s comprend un émetteur-récepteur radio. Il a été conçu de manière à respecter les limites en matière d'exposition aux fréquences radioélectriques (champs électromagnétiques de fréquence radio), recommandées dans le code de sécurité 6 de Santé Canada. Ces directives intègrent une marge de sécurité importante destinée à assurer la sécurité de tous, indépendamment de l'âge et de la santé.

Par conséquent, les systèmes sont conçus pour être exploités en évitant que l'utilisateur n'entre en contact avec les antennes. Il est recommandé de poser le système là où les antennes sont à une distance minimale telle que précisée par l'utilisateur conformément aux directives réglementaires qui sont conçues pour réduire l'exposition générale de l'utilisateur ou de l'opérateur.

Distance d'éloignement			
Fréquence	MPE	Distance	Limite
2.4 GHz	0.17 W/m ²	20 cm (7.87 inches)	5.4 W/m ²
5 GHz	0.66 W/m ²		9.2 W/m ²

Santé Canada affirme que la littérature scientifique actuelle n'indique pas qu'il faille prendre des précautions particulières lors de l'utilisation d'un appareil sans fil. Si vous voulez réduire votre exposition encore davantage, selon l'agence, vous pouvez facilement le faire en réorientant les antennes afin qu'elles soient dirigées à l'écart de l'utilisateur, en les plaçant à une distance d'éloignement supérieure à celle recommandée ou en réduisant la puissance de sortie de l'émetteur.

Additional Information on RF Exposure

You can find additional information on the subject at the following links:

- Cisco Systems Spread Spectrum Radios and RF Safety white paper at this URL: http://www.cisco.com/warp/public/cc/pd/witc/ao340ap/prodlit/rfhr_wi.htm
- FCC Bulletin 56: Questions and Answers about Biological Effects and Potential Hazards of Radio Frequency Electromagnetic Fields
- FCC Bulletin 65: Evaluating Compliance with the FCC guidelines for Human Exposure to Radio Frequency Electromagnetic Fields

You can obtain additional information from the following organizations:

- World Health Organization Internal Commission on Non-Ionizing Radiation Protection at this URL: www.who.int/emf
- United Kingdom, National Radiological Protection Board at this URL: www.nrp.org.uk
- Cellular Telecommunications Association at this URL: www.wow-com.com
- The Mobile Manufacturers Forum at this URL: www.mmfa.org

Administrative Rules for Cisco Aironet Network Sensors in Taiwan

This section provides administrative rules for operating Cisco Aironet network sensors in Taiwan. The rules for all network sensors are provided in both Chinese and English.

Chinese Translation

低功率電波輻射性電機管理辦法

第十二條 經型式認證合格之低功率射頻電機，非經許可，公司、商號或使用者均不得擅自變更頻率、加大功率或變更原設計之特性及功能。

第十四條 低功率射頻電機之使用不得影響飛航安全及干擾合法通信；經發現有干擾現象時，應立即停用，並改善至無干擾時方得繼續使用。

前項合法通信，指依電信法規定作業之無線電信。

低功率射頻電機須忍受合法通信或工業、科學及醫療用電波輻射性電機設備之干擾。

127DAB

English Translation

Administrative Rules for Low-power Radio-Frequency Devices

Article 12

For those low-power radio-frequency devices that have already received a type-approval, companies, business units or users should not change its frequencies, increase its power or change its original features and functions.

Article 14

The operation of the low-power radio-frequency devices is subject to the conditions that no harmful interference is caused to aviation safety and authorized radio station; and if interference is caused, the user must stop operating the device immediately and can't re-operate it until the harmful interference is clear.

The authorized radio station means a radio-communication service operating in accordance with the Communication Act.

The operation of the low-power radio-frequency devices is subject to the interference caused by the operation of an authorized radio station, by another intentional or unintentional radiator, by industrial, scientific and medical (ISM) equipment, or by an incidental radiator.

Chinese Translation

低功率射頻電機技術規範

4.7 無線資訊傳輸設備

4.7.5 在 5.25-5.35 兆赫頻帶內操作之無線資訊傳輸設備，限於室內使用。

4.7.6 無線資訊傳輸設備須忍受合法通信之干擾且不得干擾合法通信；如造成干擾，應立即停用，俟無干擾之虞，始得繼續使用。

4.7.7 無線資訊傳輸設備的製造廠商應確保頻率穩定性，如依製造廠商使用手冊上所述正常操作，發射的信號應維持於操作頻帶中。

English Translation

Low-power Radio-frequency Devices Technical Specifications

- 4.7 Unlicensed National Information Infrastructure
- 4.7.5 Within the 5.25-5.35 GHz band, U-NII devices will be restricted to indoor operations to reduce any potential for harmful interference to co-channel MSS operations.
- 4.7.6 The U-NII devices shall accept any interference from legal communications and shall not interfere the legal communications. If interference is caused, the user must stop operating the device immediately and can't re-operate it until the harmful interference is clear.
- 4.7.7 Manufacturers of U-NII devices are responsible for ensuring frequency stability such that an emission is maintained within the band of operation under all conditions of normal operation as specified in the user manual.

Operation of Cisco Aironet Network Sensors in Brazil

This section contains special information for operation of Cisco Aironet network sensors in Brazil.

Network Sensor Models:

AIR-AP1800S-Z-K9

Figure 13 *Brazil Regulatory Information*

Portuguese Translation

Este equipamento opera em caráter secundário, isto é, não tem direito a proteção contra interferência prejudicial, mesmo de estações do mesmo tipo, e não pode causar interferência a sistemas operando em caráter primário.

English Translation

This equipment operates on a secondary basis and consequently must accept harmful interference, including interference from stations of the same kind. This equipment may not cause harmful interference to systems operating on a primary basis.

Declaration of Conformity Statements

All the Declaration of Conformity statements related to this product can be found at the following location: <http://www.ciscofax.com>

12 Obtaining Documentation and Submitting a Service Request

For information on obtaining documentation, using the Cisco Bug Search Tool (BST), submitting a service request, and gathering additional information, see *What's New in Cisco Product Documentation*.

To receive new and revised Cisco technical content directly to your desktop, you can subscribe to the [What's New in Cisco Product Documentation RSS feed](#). The RSS feeds are a free service.

© 2017 Cisco Systems, Inc. All rights reserved.

Cisco and the Cisco logo are trademarks or registered trademarks of Cisco and/or its affiliates in the U.S. and other countries. To view a list of Cisco trademarks, go to this URL: www.cisco.com/go/trademarks. Third-party trademarks mentioned are the property of their respective owners. The use of the word partner does not imply a partnership relationship between Cisco and any other company. (1110R)

