



## Test Report

**FCC ID: LDK102099**

**AIR-AP3802E-B-K9, AIR-AP3802E-UXK9**

**AIR-AP2802E-B-K9, AIR-AP2802E-UXK9**

**IC: 2461B-102099**

**AIR-AP3802E-A-K9, AIR-AP3802E-UXK9**

**AIR-AP2802E-A-K9, AIR-AP2802E-UXK9**

Cisco Aironet 802.11ac Dual Band Access Points

### 5725-5850 MHz

Against the following Specifications:

**CFR47 Part 15.407**

**RSS-247**

**Cisco Systems**

170 West Tasman Drive

San Jose, CA 95134

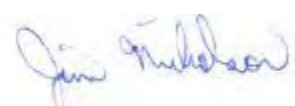
	
<b>Author:</b> Jose Aguirre <b>Tested By</b>	<b>Approved By:</b> Jim Nicholson <b>Title:</b> Technical Leader, Engineering <b>Revision:</b> 3

This report replaces any previously entered test report under EDCS – **1552002**. This test report has been electronically authorized and archived using the CISCO Engineering Document Control system.



This test report has been electronically authorized and archived using the CISCO Engineering Document Control system.

**SECTION 1: OVERVIEW .....3**

**SECTION 2: ASSESSMENT INFORMATION .....4**

    2.1 GENERAL .....4

    2.2 DATE OF TESTING.....6

    2.3 REPORT ISSUE DATE .....6

    2.4 TESTING FACILITIES .....6

    2.5 EQUIPMENT ASSESSED (EUT).....6

    2.6 EUT DESCRIPTION.....7

**SECTION 3: RESULT SUMMARY.....10**

    3.1 RESULTS SUMMARY TABLE .....10

**SECTION 4: SAMPLE DETAILS.....12**

**APPENDIX A: EMISSION TEST RESULTS.....13**

    CONDUCTED TEST SETUP DIAGRAM.....13

    TARGET MAXIMUM CHANNEL POWER .....13

    A.1 6dB BANDWIDTH.....14

    A.2 99% AND 26dB BANDWIDTH .....22

    A.3 MAXIMUM CONDUCTED OUTPUT POWER .....30

    A.4 POWER SPECTRAL DENSITY .....36

    A.5 CONDUCTED SPURIOUS EMISSIONS.....42

    A.6 CONDUCTED BANDEDGE.....57

**APPENDIX B: EMISSION TEST RESULTS.....64**

    RADIATED EMISSION SETUP DIAGRAM-BELOW 1G .....64

    RADIATED EMISSION SETUP DIAGRAM-ABOVE 1G .....64

    B.1 RADIATED SPURIOUS EMISSIONS .....65

    B.2 RADIATED RECEIVER SPURIOUS EMISSIONS .....76

    B.3 RADIATED EMISSIONS 30MHZ TO 1GHZ .....81

    B.4 AC CONDUCTED EMISSIONS .....83

**APPENDIX C: LIST OF TEST EQUIPMENT USED TO PERFORM THE TEST.....89**

**APPENDIX E: ABBREVIATION KEY AND DEFINITIONS .....91**



**Section 1: Overview**

The samples were assessed against the tests detailed in section 3 under the requirements of the following specifications:

<b>Specifications:</b>
CFR47 Part 15.407 RSS-247 Issue 1: May 2015 RSS-Gen Issue 4: Nov 2014

Measurements were made in accordance with

- ANSI C63.10:2013
- KDB 789033 D02 General UNII Test Procedures New Rules v01r01
- KDB 662911 D01 Multiple Transmitter Output v02r01



## Section 2: Assessment Information

### 2.1 General

This report contains an assessment of an apparatus against Electromagnetic Compatibility Standards based upon tests carried out on the samples submitted. The testing was performed by and for the use of Cisco systems Inc:

With regard to this assessment, the following points should be noted:

- a) The results contained in this report relate only to the items tested and were obtained in the period between the date of the initial assessment and the date of issue of the report. Manufactured products will not necessarily give identical results due to production and measurement tolerances.
- b) The apparatus was set up and exercised using the configuration and modes of operation defined in this report only.
- c) Where relevant, the apparatus was only assessed using the susceptibility criteria defined in this report and the Test Assessment Plan (TAP).
- d) All testing was performed under the following environmental conditions:

Temperature	15°C to 35°C (54°F to 95°F)
Atmospheric Pressure	860mbar to 1060mbar (25.4" to 31.3")
Humidity	10% to 75*%
- e) All AC testing was performed at one or more of the following supply voltages:  
110V 60 Hz (+/-20%)

### Units of Measurement

The units of measurements defined in the appendices are reported in specific terms, which are test dependent. Where radiated measurements are concerned these are defined at a particular distance. Basic voltage measurements are defined in units of [dBuV]

As an example, the basic calculation for all measurements is as follows:

$$\text{Emission level [dBuV]} = \text{Indicated voltage level [dBuV]} + \text{Cable Loss [dB]} + \text{Other correction factors [dB]}$$

The combinations of correction factors are dependent upon the exact test configurations [see test equipment lists for further details] and may include:-

Antenna Factors, Pre Amplifier Gain, LISN Loss, Pulse Limiter Loss and Filter Insertion Loss

Note: to convert the results from dBuV/m to uV/m use the following formula:-

$$\text{Level in uV/m} = \text{Common Antilogarithm} [(X \text{ dBuV/m})/20] = Y \text{ uV/m}$$



## Measurement Uncertainty Values

voltage and power measurements	± 2 dB
conducted EIRP measurements	± 1.4 dB
radiated measurements	± 3.2 dB
frequency measurements	± 2.4 10 <sup>-7</sup>
temperature measurements	± 0.54°
humidity measurements	± 2.3%
DC and low frequency measurements	± 2.5%

Where relevant measurement uncertainty levels have been estimated for tests performed on the apparatus. This uncertainty represents an expanded uncertainty expressed at approximately the 95% confidence level using a coverage factor of k=2.

## Radiated emissions (expanded uncertainty, confidence interval 95%)

30 MHz - 300 MHz	+/- 3.8 dB
300 MHz - 1000 MHz	+/- 4.3 dB
1 GHz - 10 GHz	+/- 4.0 dB
10 GHz - 18GHz	+/- 8.2 dB
18GHz - 26.5GHz	+/- 4.1 dB
26.5GHz - 40GHz	+/- 3.9 dB

## Conducted emissions (expanded uncertainty, confidence interval 95%)

30 MHz – 40GHz	+/- 0.38 dB
----------------	-------------

A product is considered to comply with a requirement if the nominal measured value is below the limit line. The product is considered to not be in compliance in case the nominal measured value is above the limit line.

**This report must not be reproduced except in full, without written approval of Cisco Systems.**

**2.2 Date of testing**

01-Jan-16 - 03-Mar-16

**2.3 Report Issue Date**

04-March-2016

Cisco uses an electronic system to issue, store and control the revision of test reports. This system is called the Engineering Document Control System (EDCS). The actual report issue date is embedded into the original file on EDCS. Any copies of this report, either electronic or paper, that are not on EDCS must be considered uncontrolled.

**2.4 Testing facilities**

This assessment was performed by:

**Testing Laboratory**

Cisco Systems, Inc.,  
125 West Tasman Drive  
San Jose, CA 95134, USA

**Registration Numbers for Industry Canada**

<b>Cisco System Site</b>	<b>Address</b>	<b>Site Identifier</b>
Building P, 10m Chamber	125 West Tasman Dr San Jose, CA 95134	Company #: 2461N-2
Building P, 5m Chamber	125 West Tasman Dr San Jose, CA 95134	Company #: 2461N-1
Building I, 5m Chamber	285 W. Tasman Drive San Jose, California 95134	Company #: 2461M-1

**Test Engineers**

Jose Aguirre

**2.5 Equipment Assessed (EUT)**

AIR-AP3802E-B-K9 Series



## 2.6 EUT Description

The Cisco Aironet 802.11ac Radio supports the following modes of operation. The modes are further defined in the radio Theory of Operation. The modes included in this report represent the worst case data for all modes.

- 802.11n/ac - Non HT20, One Antenna, 6 to 54 Mbps
- 802.11n/ac - Non HT20, Two Antennas, 6 to 54 Mbps
- 802.11n/ac - Non HT20, Three Antennas, 6 to 54 Mbps
- 802.11n/ac - Non HT20, Four Antennas, 6 to 54 Mbps
  
- 802.11n/ac - Non HT20 Beam Forming, Two Antennas, 6 to 54 Mbps
- 802.11n/ac - Non HT20 Beam Forming, Three Antennas, 6 to 54 Mbps
- 802.11n/ac - Non HT20 Beam Forming, Four Antennas, 6 to 54 Mbps
  
- 802.11n/ac - HT/VHT20, One Antenna, M0 to M7
- 802.11n/ac - HT/VHT20, Two Antennas, M0 to M7
- 802.11n/ac - HT/VHT20, Two Antennas, M8 to M15
- 802.11n/ac - HT/VHT20, Three Antennas, M0 to M7
- 802.11n/ac - HT/VHT20, Three Antennas, M8 to M15
- 802.11n/ac - HT/VHT20, Three Antennas, M16 to M23
- 802.11n/ac - HT/VHT20, Four Antennas, M0 to M7
- 802.11n/ac - HT/VHT20, Four Antennas, M8 to M15
- 802.11n/ac - HT/VHT20, Four Antennas, M16 to M23
  
- 802.11n/ac - HT/VHT20 Beam Forming, Two Antennas, M0 to M7
- 802.11n/ac - HT/VHT20 Beam Forming, Two Antennas, M8 to M15
- 802.11n/ac - HT/VHT20 Beam Forming, Three Antennas, M0 to M7
- 802.11n/ac - HT/VHT20 Beam Forming, Three Antennas, M8 to M15
- 802.11n/ac - HT/VHT20 Beam Forming, Three Antennas, M16 to M23
- 802.11n/ac - HT/VHT20 Beam Forming, Four Antennas, M0 to M7
- 802.11n/ac - HT/VHT20 Beam Forming, Four Antennas, M8 to M15
- 802.11n/ac - HT/VHT20 Beam Forming, Four Antennas, M16 to M23
  
- 802.11n/ac - HT/VHT20 STBC, Two Antennas, M0 to M7
- 802.11n/ac - HT/VHT20 STBC, Three Antennas, M0 to M7
- 802.11n/ac - HT/VHT20 STBC, Four Antennas, M0 to M7
  
- 802.11n/ac - Non HT40 Duplicate, One Antenna, 6 to 54 Mbps
- 802.11n/ac - Non HT40 Duplicate, Two Antennas, 6 to 54 Mbps
- 802.11n/ac - Non HT40 Duplicate, Three Antennas, 6 to 54 Mbps
- 802.11n/ac - Non HT40 Duplicate, Four Antennas, 6 to 54 Mbps
  
- 802.11n/ac - HT/VHT40, One Antenna, M0 to M7
- 802.11n/ac - HT/VHT40, Two Antennas, M0 to M7
- 802.11n/ac - HT/VHT40, Two Antennas, M8 to M15
- 802.11n/ac - HT/VHT40, Three Antennas, M0 to M7
- 802.11n/ac - HT/VHT40, Three Antennas, M8 to M15
- 802.11n/ac - HT/VHT40, Three Antennas, M16 to M23
- 802.11n/ac - HT/VHT40, Four Antennas, M0 to M7
- 802.11n/ac - HT/VHT40, Four Antennas, M8 to M15
- 802.11n/ac - HT/VHT40, Four Antennas, M16 to M23



802.11n/ac - HT/VHT40 Beam Forming, Two Antennas, M0 to M7  
802.11n/ac - HT/VHT40 Beam Forming, Two Antennas, M8 to M15  
802.11n/ac - HT/VHT40 Beam Forming, Three Antennas, M0 to M7  
802.11n/ac - HT/VHT40 Beam Forming, Three Antennas, M8 to M15  
802.11n/ac - HT/VHT40 Beam Forming, Three Antennas, M16 to M23  
802.11n/ac - HT/VHT40 Beam Forming, Four Antennas, M0 to M7  
802.11n/ac - HT/VHT40 Beam Forming, Four Antennas, M8 to M15  
802.11n/ac - HT/VHT40 Beam Forming, Four Antennas, M16 to M23

802.11n/ac - HT/VHT40 STBC, Two Antennas, M0 to M7  
802.11n/ac - HT/VHT40 STBC, Three Antennas, M0 to M7  
802.11n/ac - HT/VHT40 STBC, Four Antennas, M0 to M7

802.11n/ac - Non HT80 Duplicate, One Antenna, 6 to 54 Mbps  
802.11n/ac - Non HT80 Duplicate, Two Antennas, 6 to 54 Mbps  
802.11n/ac - Non HT80 Duplicate, Three Antennas, 6 to 54 Mbps  
802.11n/ac - Non HT80 Duplicate, Four Antennas, 6 to 54 Mbps

802.11ac - VHT80, One Antenna, M0.1 to M9.1  
802.11ac - VHT80, Two Antennas, M0.1 to M9.1  
802.11ac - VHT80, Two Antennas, M0.2 to M9.2  
802.11ac - VHT80, Three Antennas, M0.1 to M9.1  
802.11ac - VHT80, Three Antennas, M0.2 to M9.2  
802.11ac - VHT80, Three Antennas, M0.3 to M9.3  
802.11ac - VHT80, Four Antennas, M0.1 to M9.1  
802.11ac - VHT80, Four Antennas, M0.2 to M9.2  
802.11ac - VHT80, Four Antennas, M0.3 to M9.3

802.11ac - VHT80 Beam Forming, Two Antennas, M0.1 to M9.1  
802.11ac - VHT80 Beam Forming, Two Antennas, M0.2 to M9.2  
802.11ac - VHT80 Beam Forming, Three Antennas, M0.1 to M9.1  
802.11ac - VHT80 Beam Forming, Three Antennas, M0.2 to M9.2  
802.11ac - VHT80 Beam Forming, Three Antennas, M0.3 to M9.3  
802.11ac - VHT80 Beam Forming, Four Antennas, M0.1 to M9.1  
802.11ac - VHT80 Beam Forming, Four Antennas, M0.2 to M9.2  
802.11ac - VHT80 Beam Forming, Four Antennas, M0.3 to M9.3

802.11ac - VHT80 STBC, Two Antennas, M0.1 to M9.1  
802.11ac - VHT80 STBC, Three Antennas, M0.1 to M9.1  
802.11ac - VHT80 STBC, Four Antennas, M0.1 to M9.1





The following antennas are supported by this product series.  
The data included in this report represent the worst case data for all antennas.

Frequency	Part Number	Antenna Type	Antenna Gain (dBi)	Model
<b>5 GHz</b>	AIR-ANT5140V-R	MIMO 3-Element Omni	4	3800E
	AIR-ANT5140NV-R	MIMO Wall-Mount Omni Antenna	4	3800E
	AIR-ANT5145V-R	Diversity Omni-directional	4.5	3800E
	AIR-ANT5160NP-R	MIMO 3-Element Patch	6	3800E
<b>2.4 / 5 GHz</b>	AIR-ANT2451V-R	Omni	2 / 3	3800E
	AIR-ANT2451NV-R	Omni	3 / 4	3800E
	AIR-ANT2524DB-R	Dual-resonant black dipole	2 / 4	2800E/3800E
	AIR-ANT2524DW-R	Dual-resonant white dipole	2 / 4	2800E/3800E
	AIR-ANT2524DG-R	Dual-resonant gray dipole	2 / 4	2800E/3800E
	AIR-ANT2524V4C-R	Dual-resonant ceiling mount omni (4-pack)	2 / 4	2800E/3800E
	AIR-ANT2535SDW-R	Dual-resonant "stubby" monopole	3 / 5	2800E/3800E
	AIR-ANT2544V4M-R	Dual-resonant omni (4-pack)	4 / 4	2800E/3800E
	AIR-ANT2566P4W-R	Dual-resonant "directional" antenna (4-pack)	6 / 6	2800E/3800E
	AIR-ANT25-LOC-02	Directional HL / Directional WiFi	4 / 4	2800E/3800E
	AIR-ANT25-LOC-03	Linear HL / Omni WiFi	1 / 3	2800E/3800E
	AIR-ANT25-LOC-04	Omni HL / Omni WiFi	1 / 3	2800E/3800E



### Section 3: Result Summary

#### 3.1 Results Summary Table

##### Conducted emissions

Basic Standard	Technical Requirements / Details	Result
FCC 15.407 RSS-247	<b>6dB Bandwidth:</b> Systems using digital modulation techniques may operate in the 2400-2483.5MHz band. The minimum 6dB bandwidth shall be at least 500 kHz.	Pass
FCC 15.407 RSS-247	<b>99% &amp; 26 dB Bandwidth:</b> The 99% occupied bandwidth is the frequency bandwidth such that, below its lower and above its upper frequency limits, the mean powers are each equal to 0.5% of the total mean power of the given emission. There is no limit for 99% OBW.  The 26 dB emission is the width of the emission that is constrained by the frequencies associated with the two outermost amplitude points (upper and lower frequencies) that are attenuated by 26 dB relative to the maximum level measured in the fundamental emission.	Pass
FCC 15.407 RSS-247	<b>Output Power:</b> For the band 5.725-5.85 GHz, the maximum conducted output power over the frequency band of operation shall not exceed 1 W.	Pass
FCC 15.407 RSS-247	<b>Power Spectral Density:</b> <b>15.407</b> The maximum power spectral density shall not exceed 30 dBm in any 500-kHz band.	Pass
FCC 15.407 RSS-247	<b>Conducted Spurious Emissions / Band-Edge:</b> For transmitters operating in the 5.725-5.85 GHz band: All emissions within the frequency range from the band edge to 10 MHz above or below the band edge shall not exceed an e.i.r.p. of -17 dBm/MHz; for frequencies 10 MHz or greater above or below the band edge, emissions shall not exceed an e.i.r.p. of -27 dBm/MHz.	Pass
FCC 15.407 FCC 15.209 FCC 152.05 RSS-247 RSS-Gen	<b>Restricted band:</b> Unwanted emissions falling within the restricted bands, as defined in FCC 15.205 (a) must also comply with the radiated emission limits specified in FCC 15.209 (a).	Pass

**Radiated Emissions (General requirements)**

<b>Basic Standard</b>	<b>Technical Requirements / Details</b>	<b>Result</b>
FCC 15.407 FCC 15.209 FCC 15.205 RSS-Gen	<b>TX Spurious Emissions:</b> Except as provided elsewhere in this subpart, the emissions from an intentional radiator shall not exceed the field strength levels specified in the filed strength limits table in this section.	Pass
FCC 15.207 RSS-Gen	<b>AC conducted Emissions:</b> Except when the requirements applicable to a given device state otherwise, for any radio apparatus equipped to operate from the public utility AC power supply, either directly or indirectly (such as with a battery charger), the radio frequency voltage of emissions conducted back onto the AC power lines in the frequency range of 0.15 MHz to 30 MHz shall not exceed the limits shown in the table in these sections. The more stringent limit applies at the frequency range boundaries.	Pass

\* MPE calculation is recorded in a separate report



## Section 4: Sample Details

Note: Each sample was evaluated to ensure that its condition was suitable to be used as a test sample prior to the commencement of testing.

### 4.1 Sample Details

Sample No.	Equipment Details	Manufacturer	Hardware Rev.	Firmware Rev.	Software Rev.	Serial Number
S01	AIR-AP3802E-B-K9 Series	Cisco Systems	01	Linux ver 3.14.33	U-boot	FOC1945132D
S02*	PWR-CUBE-B 341-100460-001	Delta	A0	NA	NA	Engineering sample

(\*) S02 are support equipment Power supplies for EUT S01

### 4.2 System Details

System #	Description	Samples
1	AIR-AP3802E-B-K9 Series	S01
2	PWR-CUBE-B	S02

### 4.3 Mode of Operation Details

Mode#	Description	Comments
1	Continuous Transmitting	Continuous Transmitting $\geq 98\%$ duty cycle

All measurements were made in accordance with

- ANSI C63.10:2013
- KDB 789033 D02 General UNII Test Procedures New Rules v01r01
- KDB 662911 D01 Multiple Transmitter Output v02r01

**Appendix A: Emission Test Results**

**Conducted Test Setup Diagram**

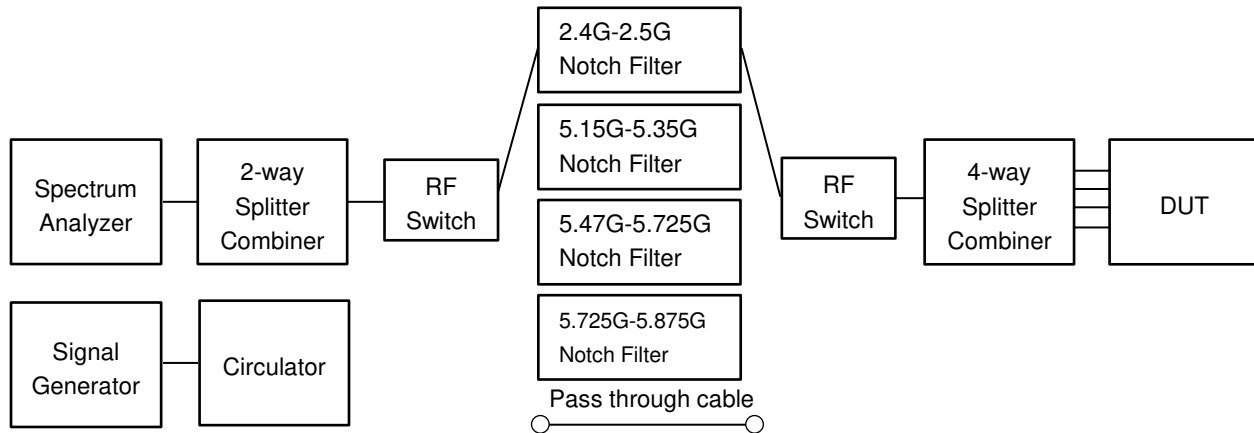

**Target Maximum Channel Power**

The following table details the maximum supported Total Channel Power for all operating modes.

Operating Mode	Maximum Channel Power (dBm)		
	Frequency (MHz)		
	5745	5785	5825
Non HT20, 6 to 54 Mbps	15	23	16
Non HT20 Beam Forming, 6 to 54 Mbps	12	23	13
HT/VHT20, M0 to M23, M0 to M9 1-0ss	16	23	16
HT/VHT20 Beam Forming, M0 to M23, M0 to M9 1-0ss	16	23	16
HT/VHT20 STBC, M0 to M7	16	23	16
	5755	5795	
Non HT40, 6 to 54 Mbps	8	22	
HT/VHT40, M0 to M23, M0 to M9 1-0ss	15	23	
HT/VHT40 Beam Forming, M0 to M23, M0 to M9 1-0ss	13	23	
HT/VHT40 STBC, M0 to M7	13	23	
	5775		
Non HT80, 6 to 54 Mbps	14		
VHT80, M0 to M9, M0 to M9 1-0ss	18		
VHT80 Beam Forming, M0 to M9, M0 to M9 1-0ss	18		
VHT80 STBC, M0.1 to M9.1	18		



## A.1 6dB Bandwidth

15.407 Within the 5.725-5.85 GHz band, the minimum 6 dB bandwidth of U-NII devices shall be at least 500 kHz.

### Test Procedure

Ref. KDB 789033 D02 General UNII Test Procedures New Rules v01r01  
ANSI C63.10: 2013

<p><b>6 BW</b> Test Procedure</p> <ol style="list-style-type: none"> <li>1. Set the radio in the continuous transmitting mode.</li> <li>2. Allow the trace to stabilize.</li> <li>3. Setting the x-dB bandwidth mode to -6dB within the measurement set up function.</li> <li>4. Select the automatic OBW measurement function of an instrument to perform bandwidth measurement.</li> <li>5. Capture graphs and record pertinent measurement data.</li> </ol>
--

Ref. KDB 789033 D02 General UNII Test Procedures New Rules v01r01  
ANSI C63.10: 2013 section 11.8.2 Option 2

<p><b>6 BW</b> Test parameters</p> <p>X dB BW = 6dB (using the OBW function of the spectrum analyzer) Span = Large enough to capture the entire EBW RBW = 100 KHz VBW ≥ 3 x RBW Sweep = Auto couple Detector = Peak or where practical sample shall be used Trace = Max. Hold</p>
---

System Number	Description	Samples	System under test	Support equipment
1	EUT	S01	<input checked="" type="checkbox"/>	<input type="checkbox"/>
	Support	S02	<input type="checkbox"/>	<input checked="" type="checkbox"/>

<p><b>Tested By :</b> Jose Aguirre</p>	<p><b>Date of testing:</b> 01-Jan-16 - 03-Mar-16</p>
<p><b>Test Result : PASS</b></p>	

See Appendix C for list of test equipment



Frequency (MHz)	Mode	Data Rate (Mbps)	6dB BW (MHz)	Limit (kHz)	Margin (MHz)
5745	Non HT20, 6 to 54 Mbps	6	16.4	>500	15.9
	HT/VHT20, M0 to M23, M0 to M9 1-0ss	m0	17.6	>500	17.1
5755	Non HT40, 6 to 54 Mbps	6	35.9	>500	35.4
	HT/VHT40, M0 to M23, M0 to M9 1-0ss	m0	35.6	>500	35.1
5775	Non HT80, 6 to 54 Mbps	6	76.5	>500	76.0
	VHT80, M0 to M9, M0 to M9 1-0ss	m0x1	76.2	>500	75.7
5785	Non HT20, 6 to 54 Mbps	6	16.4	>500	15.9
	HT/VHT20, M0 to M23, M0 to M9 1-0ss	m0	17.6	>500	17.1
5795	Non HT40, 6 to 54 Mbps	6	35.8	>500	35.3
	HT/VHT40, M0 to M23, M0 to M9 1-0ss	m0	35.6	>500	35.1
5825	Non HT20, 6 to 54 Mbps	6	16.4	>500	15.9
	HT/VHT20, M0 to M23, M0 to M9 1-0ss	m0	17.6	>500	17.1



**6dB Bandwidth, 5745 MHz, Non HT20, 6 to 54 Mbps**

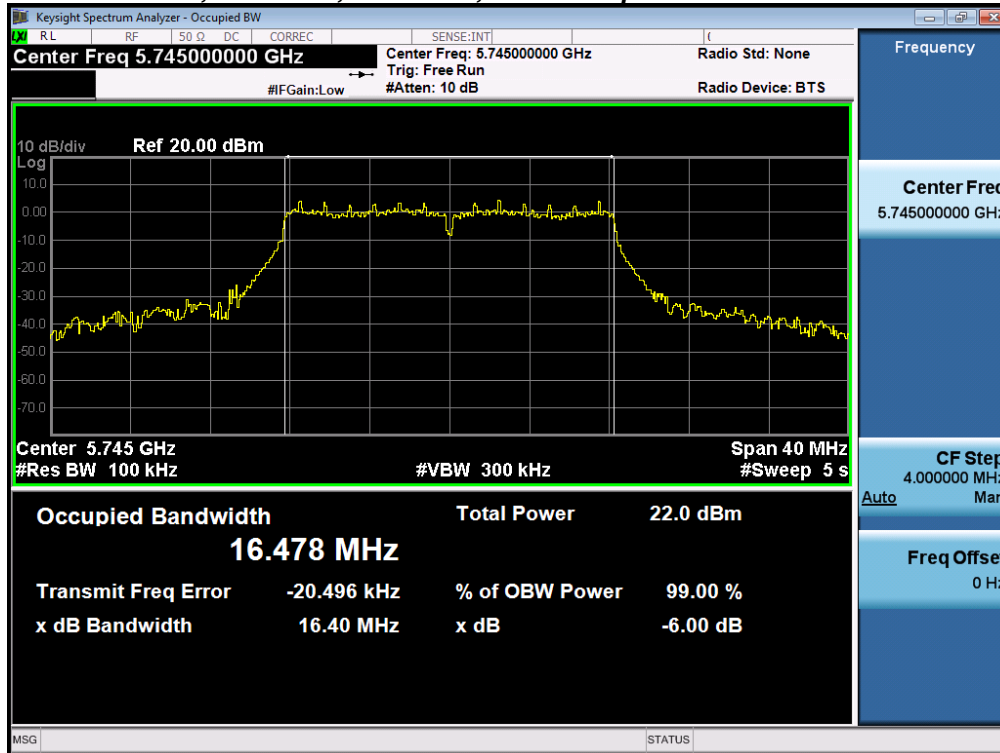

**6dB Bandwidth, 5745 MHz, HT/VHT20, M0 to M23, M0 to M9 1-0ss**

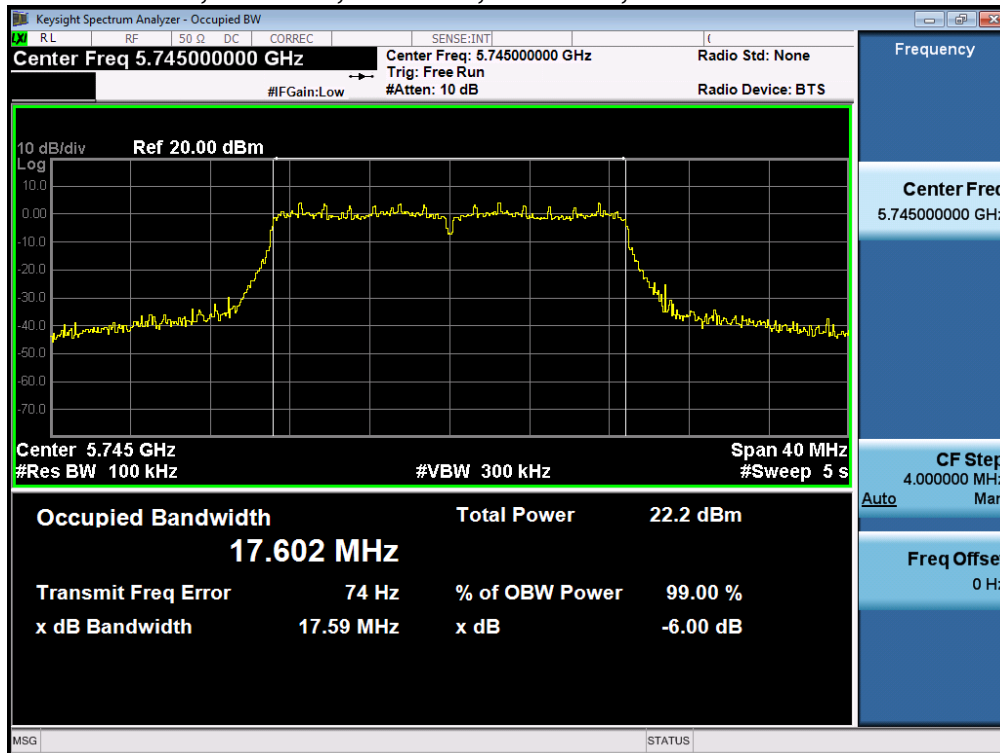





**6dB Bandwidth, 5755 MHz, Non HT40, 6 to 54 Mbps**

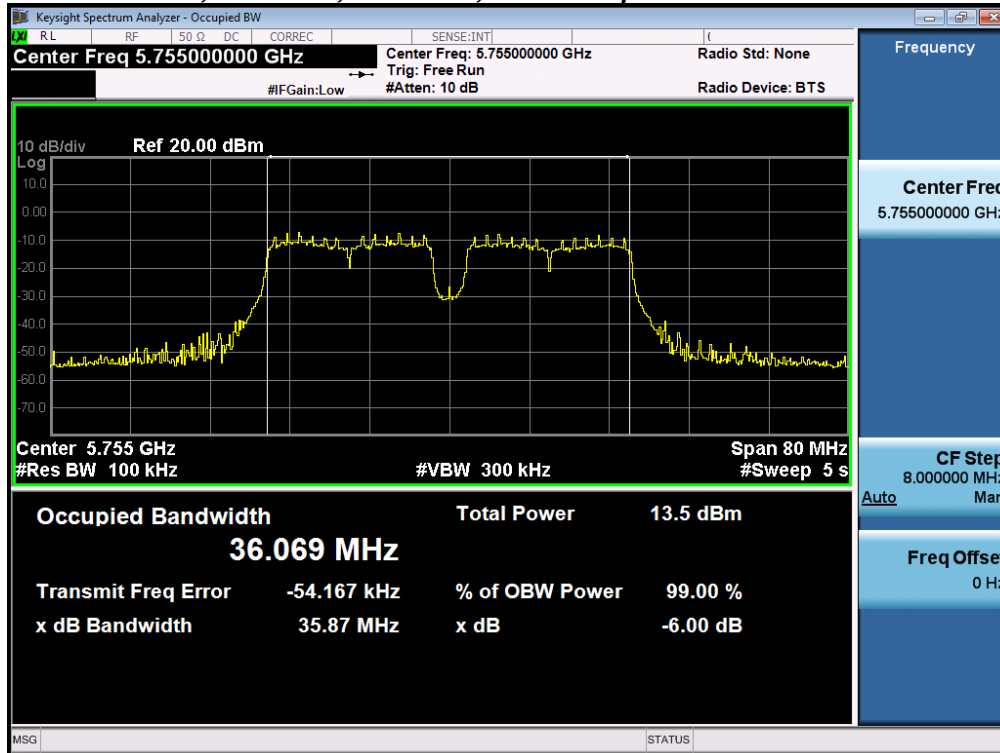

**6dB Bandwidth, 5755 MHz, HT/VHT40, M0 to M23, M0 to M9 1-0ss**

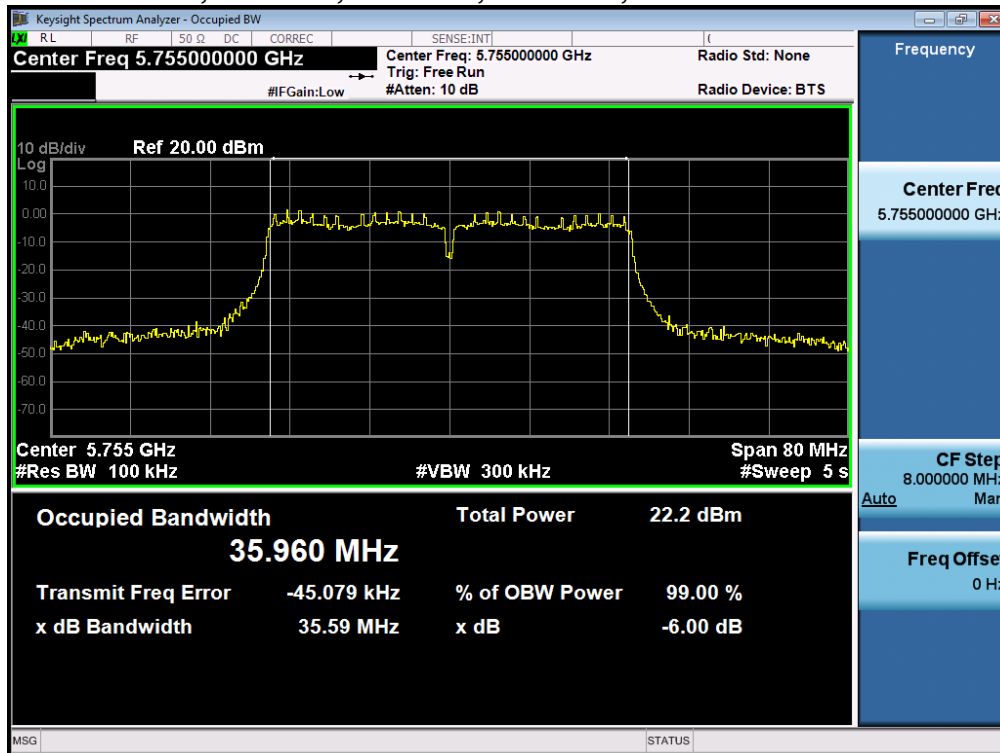



**6dB Bandwidth, 5775 MHz, Non HT80, 6 to 54 Mbps**

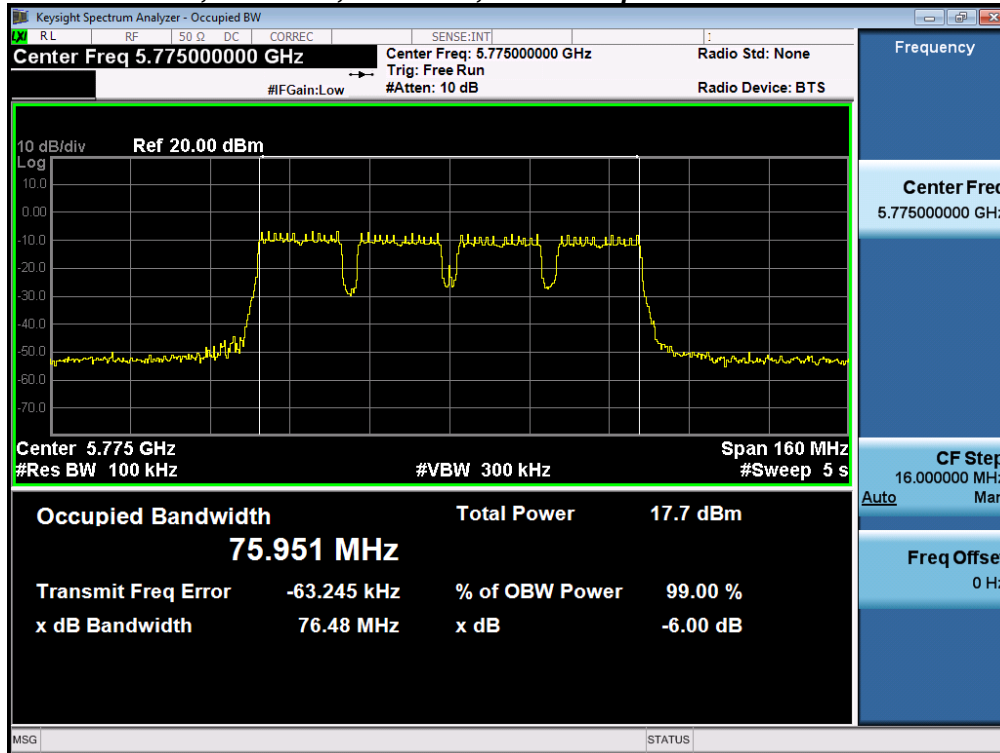

**6dB Bandwidth, 5775 MHz, VHT80, M0 to M9, M0 to M9 1-0ss**

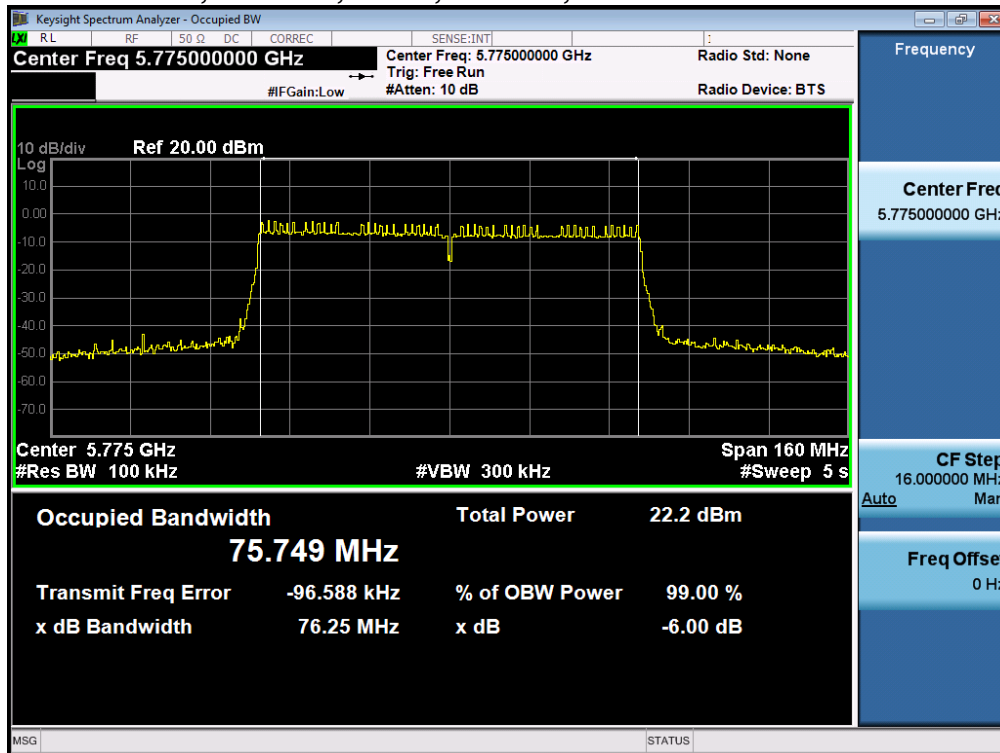



**6dB Bandwidth, 5785 MHz, Non HT20, 6 to 54 Mbps**

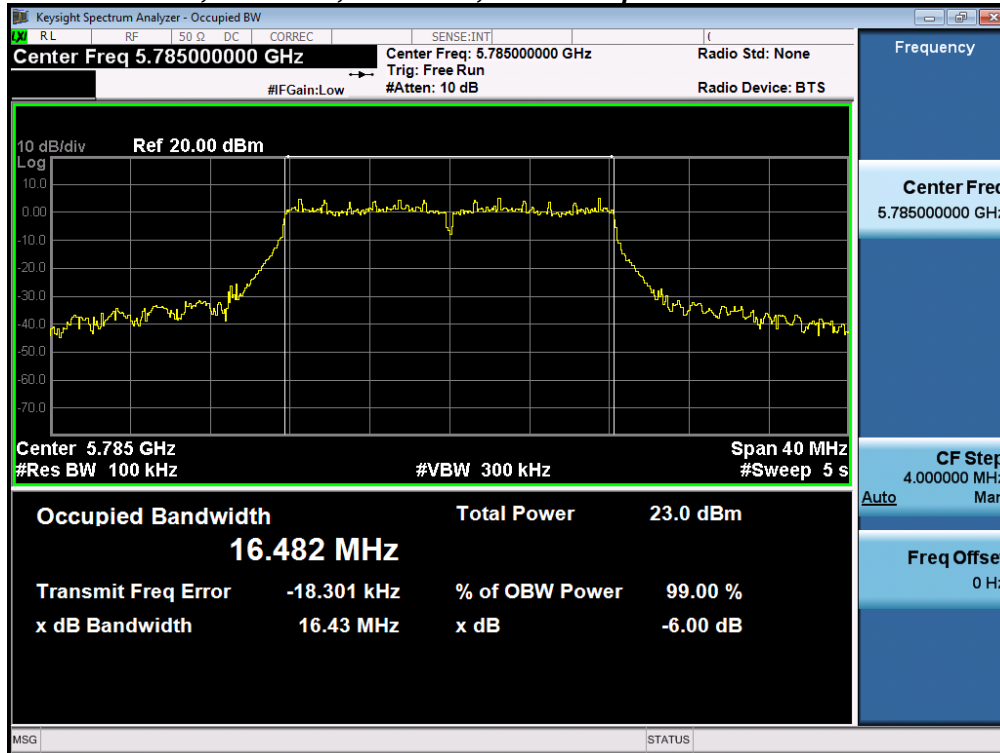

**6dB Bandwidth, 5785 MHz, HT/VHT20, M0 to M23, M0 to M9 1-0ss**

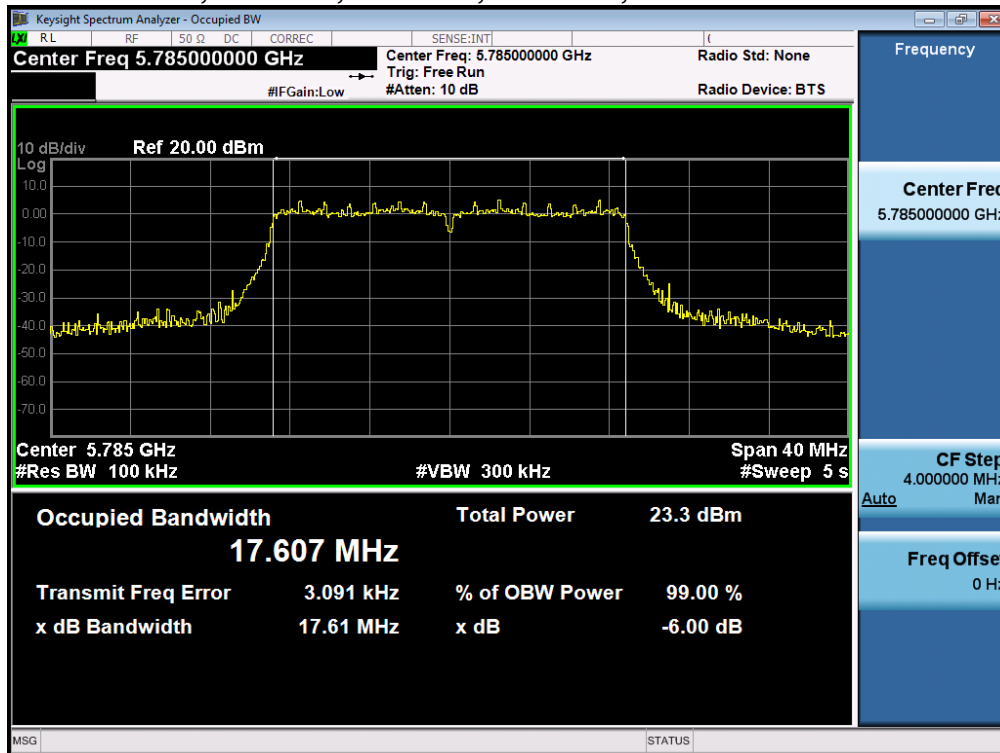



**6dB Bandwidth, 5795 MHz, Non HT40, 6 to 54 Mbps**

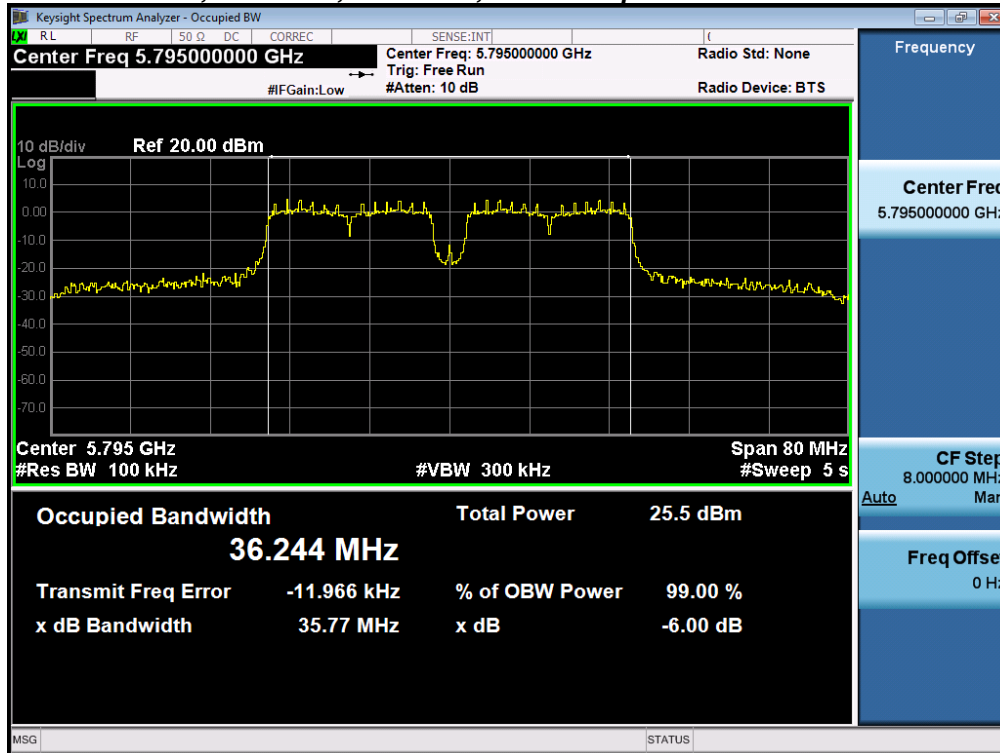

**6dB Bandwidth, 5795 MHz, HT/VHT40, M0 to M23, M0 to M9 1-0ss**

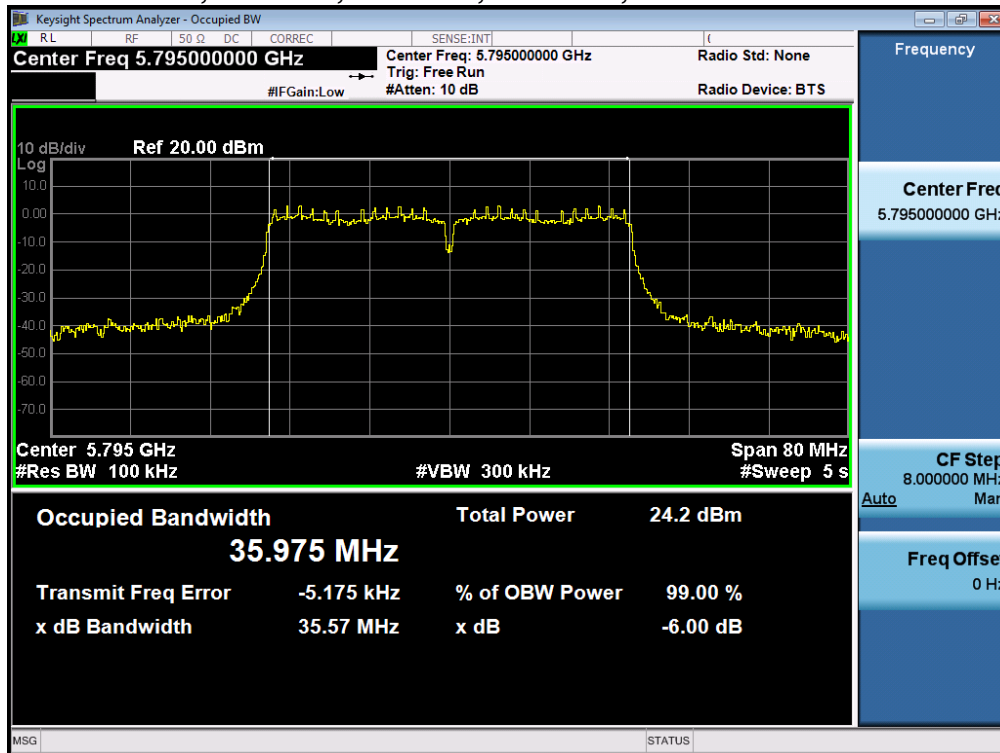



**6dB Bandwidth, 5825 MHz, Non HT20, 6 to 54 Mbps**

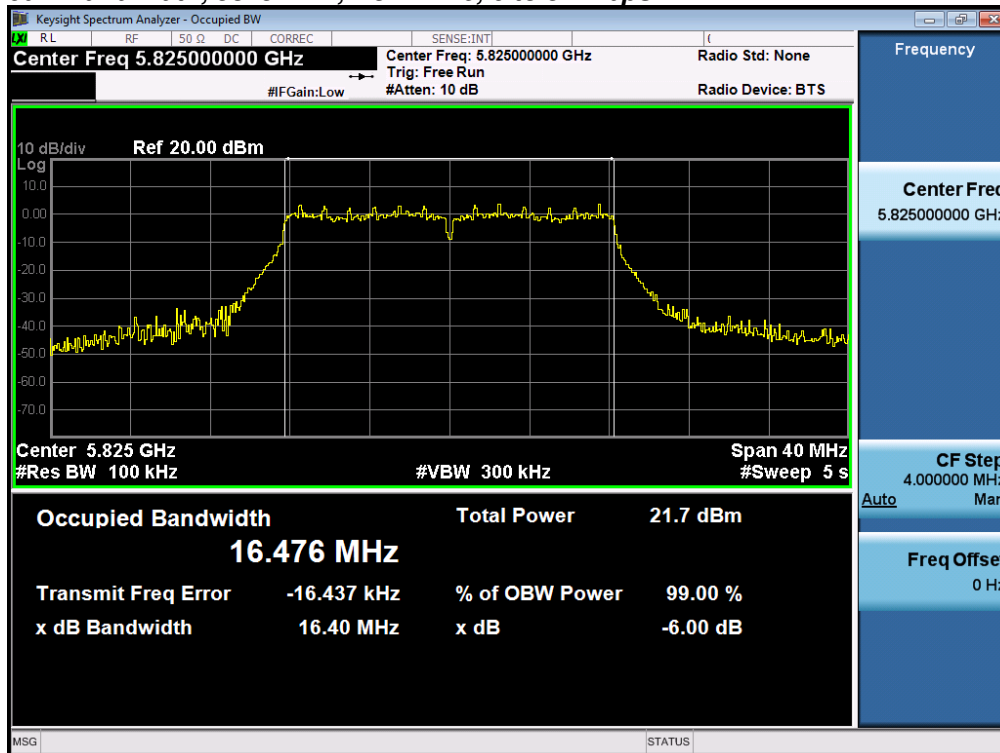

**6dB Bandwidth, 5825 MHz, HT/VHT20, M0 to M23, M0 to M9 1-0ss**

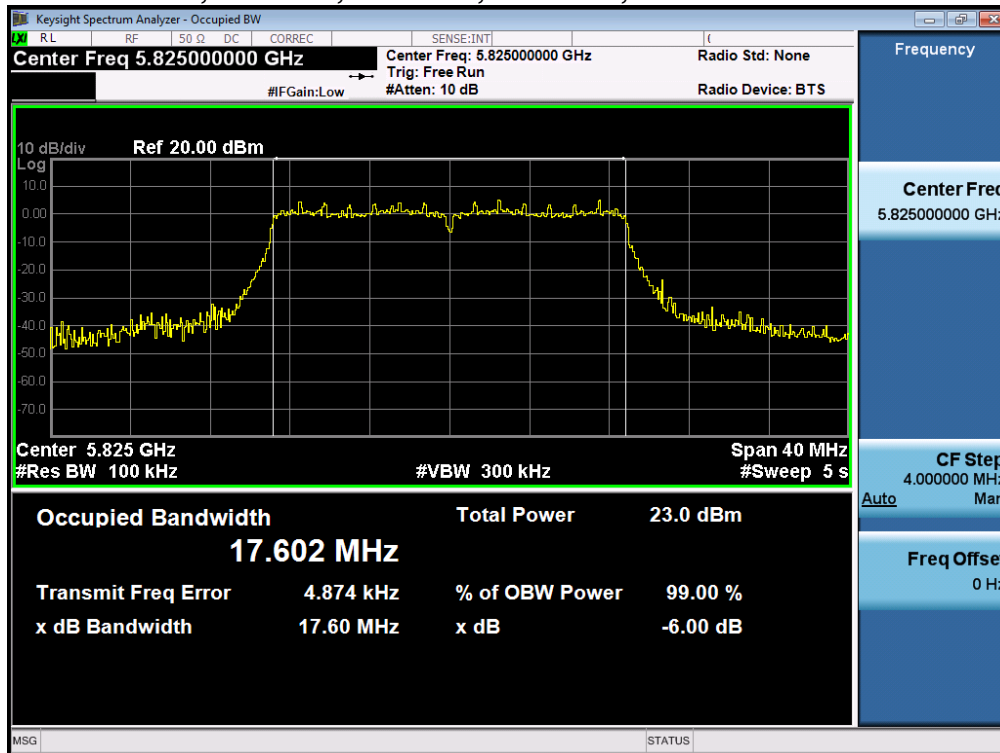



## A.2 99% and 26dB Bandwidth

**FCC 15.407** The 99% occupied bandwidth is the frequency bandwidth such that, below its lower and above its upper frequency limits, the mean powers are each equal to 0.5% of the total mean power of the given emission. There is no limit for 99% OBW.

The 26 dB emission is the width of the emission that is constrained by the frequencies associated with the two outermost amplitude points (upper and lower frequencies) that are attenuated by 26 dB relative to the maximum level measured in the fundamental emission.

### Test Procedure

Ref. ANSI C63.10: 2013 Section 6.9.3

#### 99% BW and EBW (-26dB)

Test Procedure

1. Set the radio in the continuous transmitting mode.
2. Allow the trace to stabilize.
3. Setting the x-dB bandwidth mode to -26dB and OBW power function to 99% within the measurement set up function.
4. Select the automatic OBW measurement function of an instrument to perform bandwidth measurement.
5. Capture graphs and record pertinent measurement data.

Ref. ANSI C63.10: 2013 Section 6.9.3

#### 99% BW and EBW (-26dB)

Test parameters

Span = 1.5 x to 5.0 times OBW  
 RBW = approx. 1% to 5% of the OBW  
 VBW ≥ 3 x RBW  
 Detector = Peak or where practical sample shall be used  
 Trace = Max. Hold

System Number	Description	Samples	System under test	Support equipment
1	EUT	S01	<input checked="" type="checkbox"/>	<input type="checkbox"/>
	Support	S02	<input type="checkbox"/>	<input checked="" type="checkbox"/>

<b>Tested By :</b> Jose Aguirre	<b>Date of testing:</b> 01-Jan-16 - 03-Mar-16
<b>Test Result : PASS</b>	

See Appendix C for list of test equipment



Frequency (MHz)	Mode	Data Rate (Mbps)	26dB BW (MHz)	99% BW (MHz)
5745	Non HT20, 6 to 54 Mbps	6	25.8	18.0
	HT/VHT20, M0 to M23, M0 to M9 1-0ss	m0	22.8	18.3
5755	Non HT40, 6 to 54 Mbps	6	48.4	36.9
	HT/VHT40, M0 to M23, M0 to M9 1-0ss	m0	43.6	36.6
5775	Non HT80, 6 to 54 Mbps	6	83.9	76.4
	VHT80, M0 to M9, M0 to M9 1-0ss	m0x1	84.5	76.6
5785	Non HT20, 6 to 54 Mbps	6	24.0	18.0
	HT/VHT20, M0 to M23, M0 to M9 1-0ss	m0	23.5	18.3
5795	Non HT40, 6 to 54 Mbps	6	76.2	38.3
	HT/VHT40, M0 to M23, M0 to M9 1-0ss	m0	43.8	36.6
5825	Non HT20, 6 to 54 Mbps	6	22.1	17.9
	HT/VHT20, M0 to M23, M0 to M9 1-0ss	m0	26.6	18.3



**26dB / 99% Bandwidth, 5745 MHz, Non HT20, 6 to 54 Mbps**

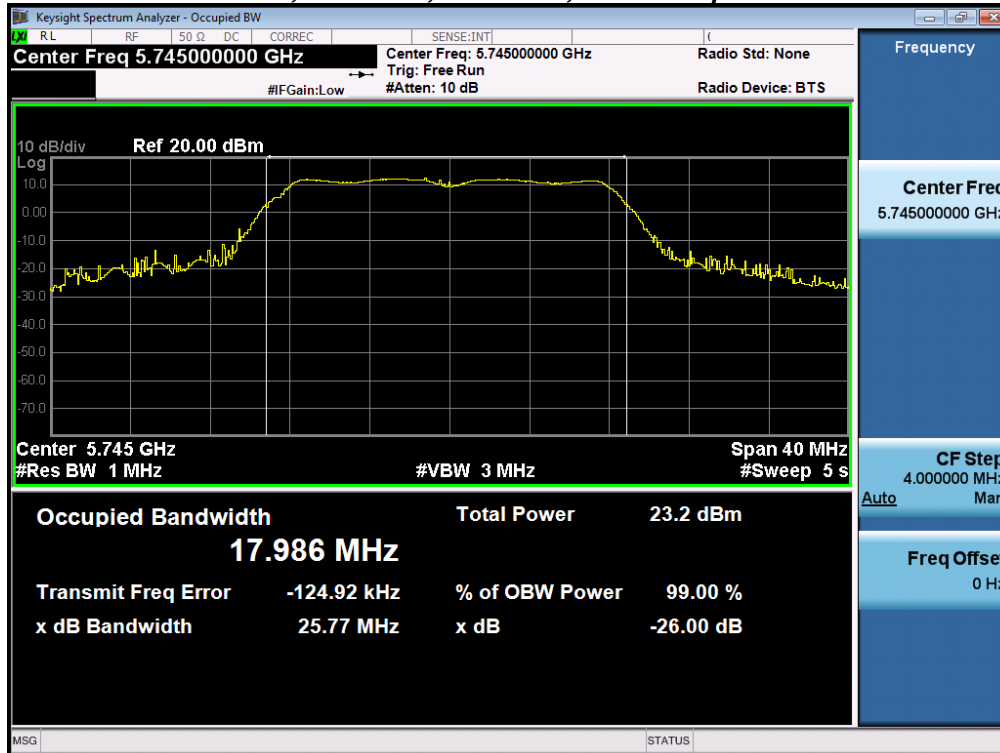

**26dB / 99% Bandwidth, 5745 MHz, HT/VHT20, M0 to M23, M0 to M9 1-0ss**

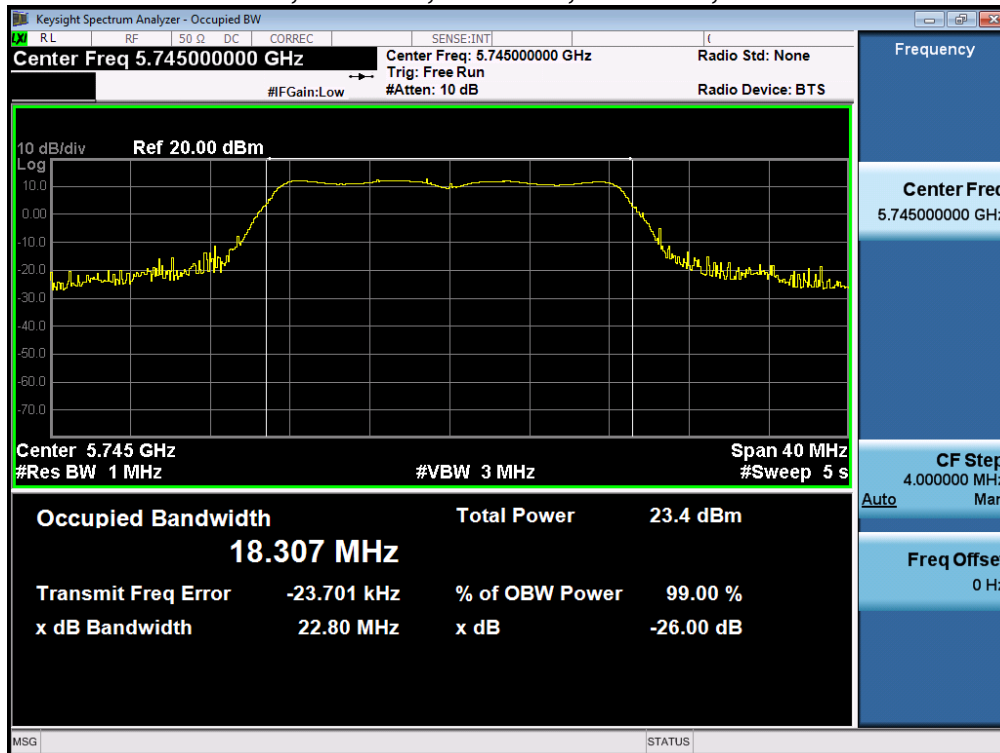





**26dB / 99% Bandwidth, 5755 MHz, Non HT40, 6 to 54 Mbps**

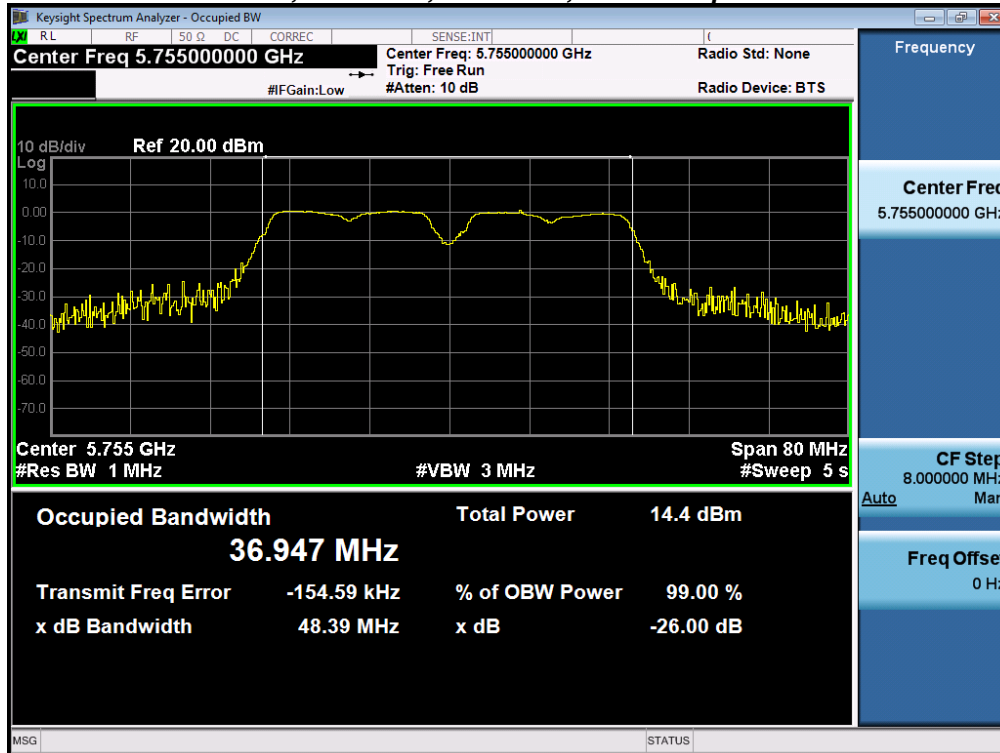

**26dB / 99% Bandwidth, 5755 MHz, HT/VHT40, M0 to M23, M0 to M9 1-0ss**

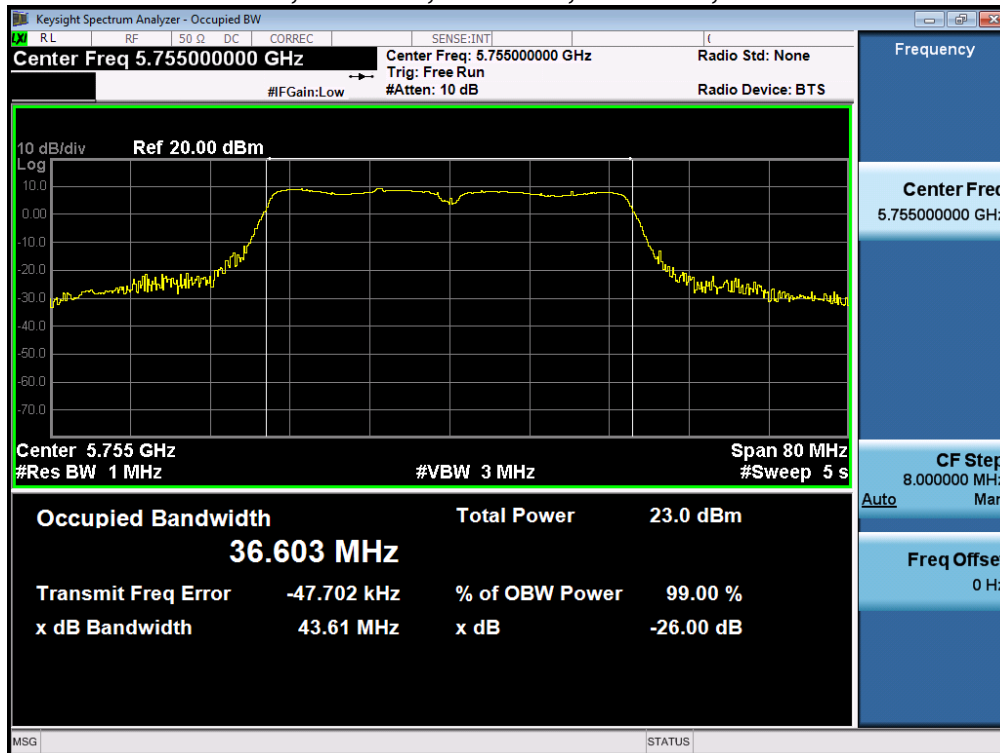



**26dB / 99% Bandwidth, 5775 MHz, Non HT80, 6 to 54 Mbps**

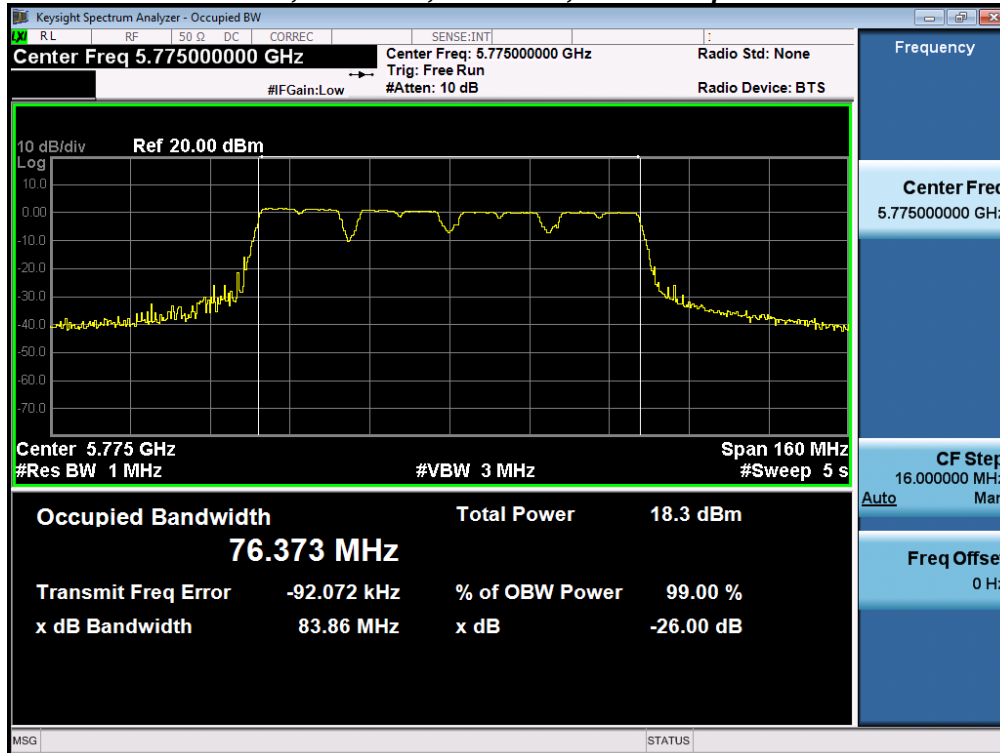

**26dB / 99% Bandwidth, 5775 MHz, VHT80, M0 to M9, M0 to M9 1-0ss**

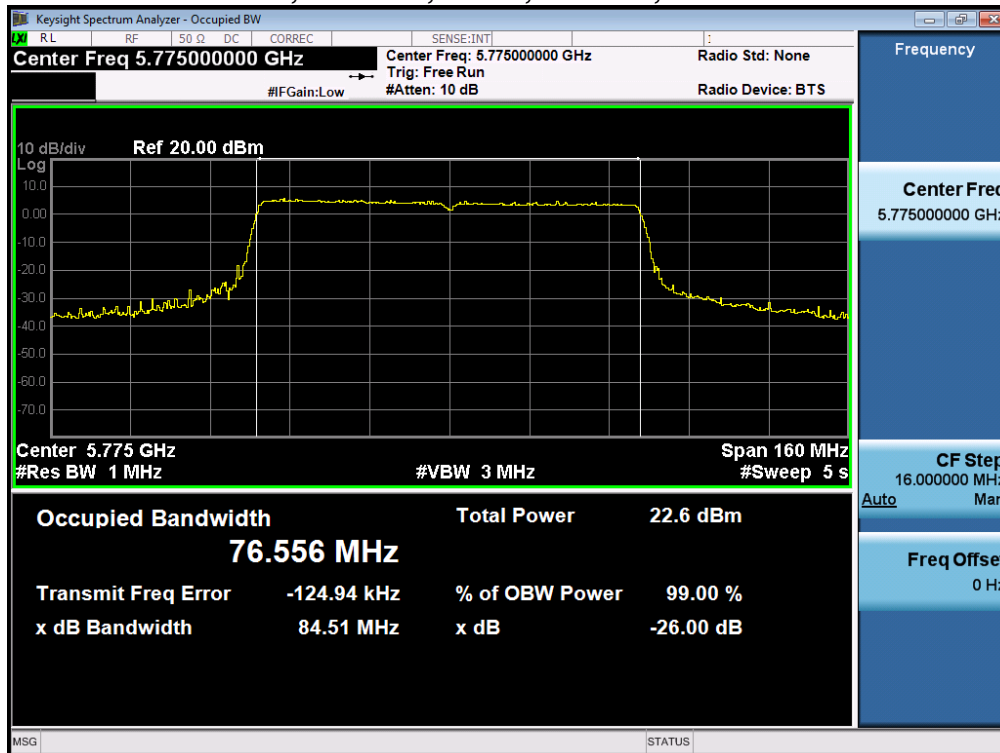



**26dB / 99% Bandwidth, 5785 MHz, Non HT20, 6 to 54 Mbps**

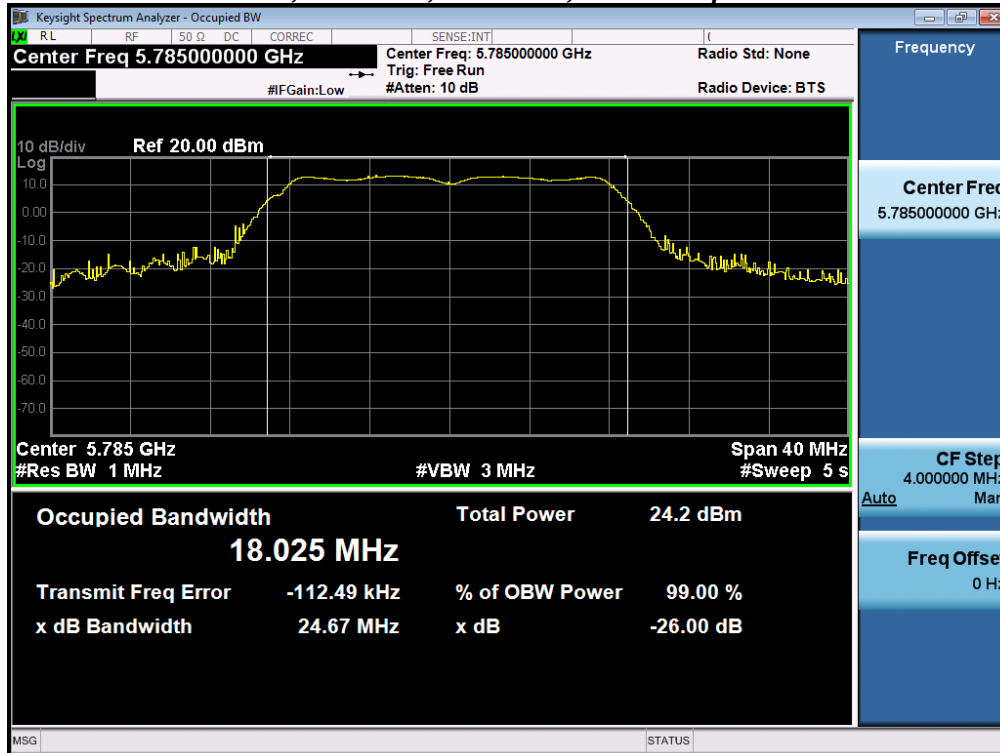

**26dB / 99% Bandwidth, 5785 MHz, HT/VHT20, M0 to M23, M0 to M9 1-0ss**

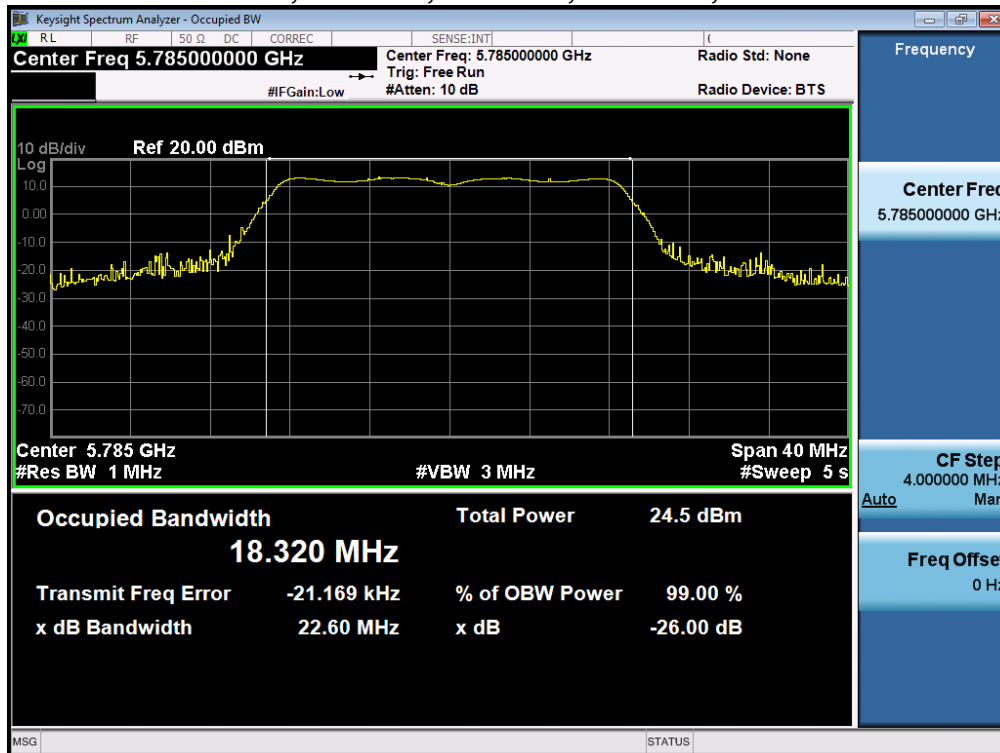



**26dB / 99% Bandwidth, 5795 MHz, Non HT40, 6 to 54 Mbps**

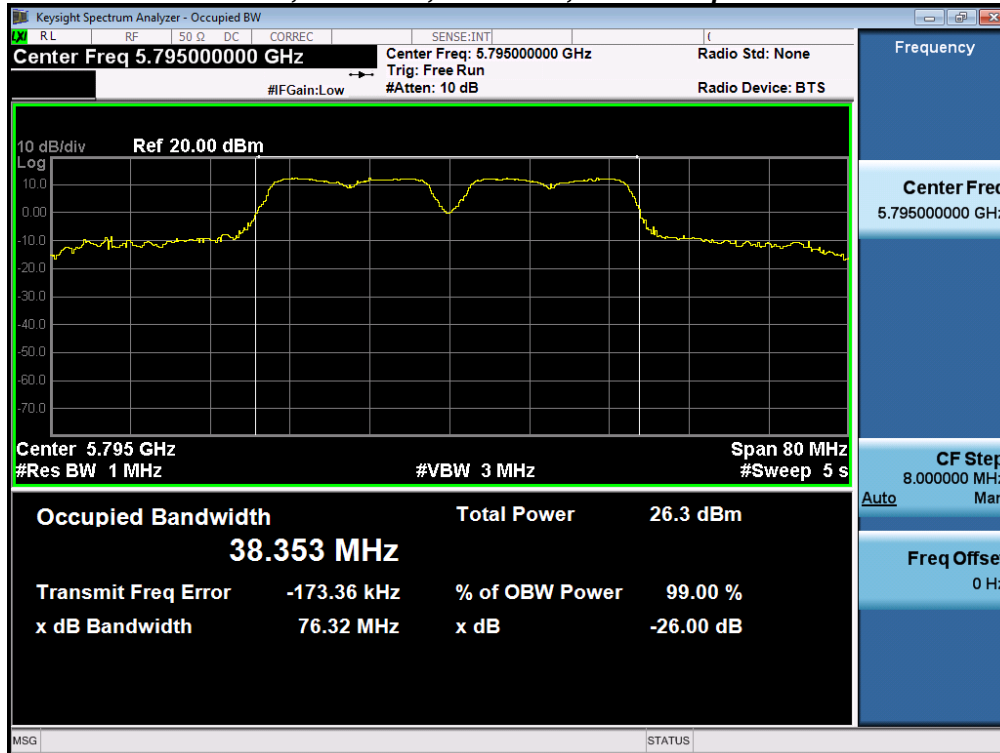

**26dB / 99% Bandwidth, 5795 MHz, HT/VHT40, M0 to M23, M0 to M9 1-0ss**

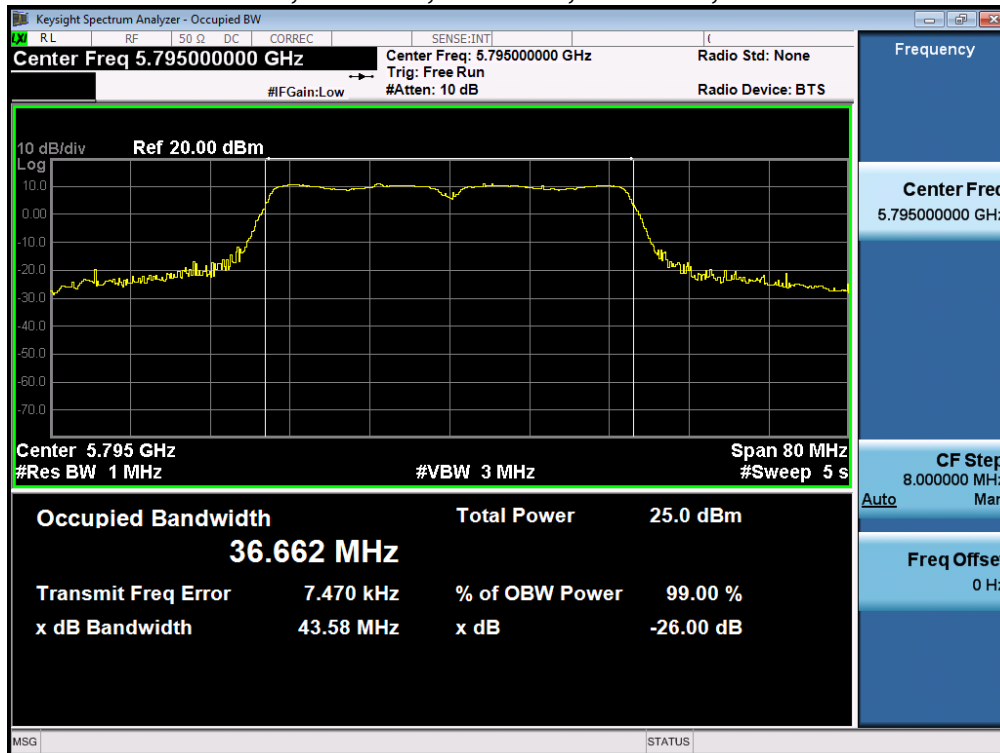



**26dB / 99% Bandwidth, 5825 MHz, Non HT20, 6 to 54 Mbps**

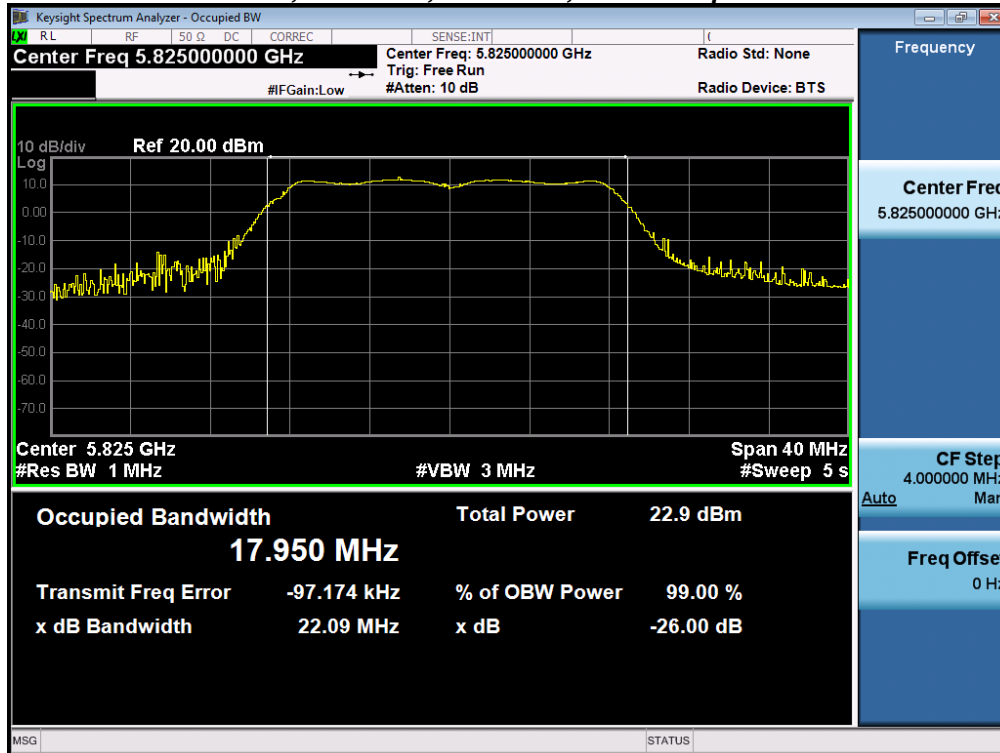

**26dB / 99% Bandwidth, 5825 MHz, HT/VHT20, M0 to M23, M0 to M9 1-0ss**

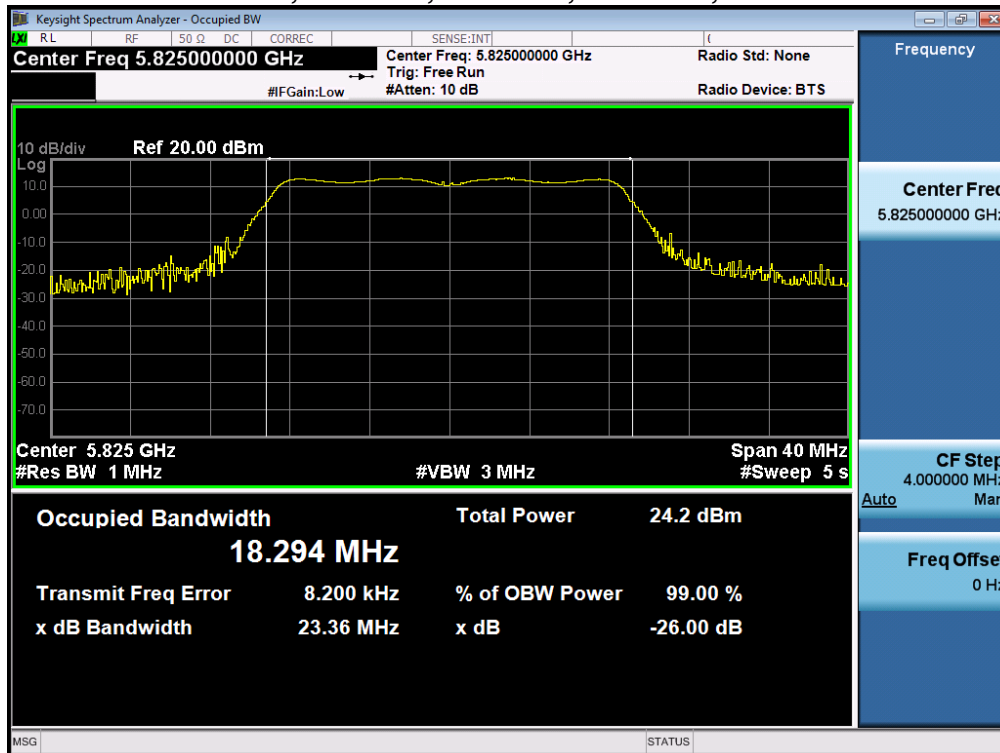



### A.3 Maximum Conducted Output Power

**15.407** (3) For the band 5.725-5.85 GHz, the maximum conducted output power over the frequency band of operation shall not exceed 1 W. In addition, the maximum power spectral density shall not exceed 30 dBm in any 500-kHz band. If transmitting antennas of directional gain greater than 6 dBi are used, both the maximum conducted output power and the maximum power spectral density shall be reduced by the amount in dB that the directional gain of the antenna exceeds 6 dBi. However, fixed point-to-point U-NII devices operating in this band may employ transmitting antennas with directional gain greater than 6 dBi without any corresponding reduction in transmitter conducted power. Fixed, point-to-point operations exclude the use of point-to-multipoint systems, omnidirectional applications, and multiple collocated transmitters transmitting the same information. The operator of the U-NII device, or if the equipment is professionally installed, the installer, is responsible for ensuring that systems employing high gain directional antennas are used exclusively for fixed, point-to-point operations.

**Test Procedure**

**Ref.** KDB 789033 D02 General UNII Test Procedures New Rules v01r01  
ANSI C63.10: 2013

<b>Output Power</b> Test Procedure
<ol style="list-style-type: none"> <li>1. Set the radio in the continuous transmitting mode at full power</li> <li>2. Compute power by integrating the spectrum across the EBW (or alternatively entire 99% OBW) of the signal using the instrument's band power measurement function. The integration shall be performed using the spectrum analyzer band-power measurement function with band limits set equal to the EBW or the OBW band edges.</li> <li>3. Capture graphs and record pertinent measurement data.</li> </ol>

**Ref.** KDB 789033 D02 General UNII Test Procedures New Rules v01r01  
ANSI C63.10: 2013 section 12.3.2.2 Method SA-1

<b>Output Power</b> Test parameters
Span = >1.5 times the OBW RBW = 1MHz VBW ≥ 3 x RBW Sweep = Auto couple Detector = sample Trace = Trace Average 100

The "measure-and-sum technique" is used for measuring in-band transmit power of a device. In the measure-and-sum approach, the conducted emission level is measured at each antenna port. The measured results at the various antenna ports are then summed mathematically to determine the total emission level from the device. Summing is performed in linear power units. (See ANSI C63.10 section 14.3.2.2)

System Number	Description	Samples	System under test	Support equipment
1	EUT	S01	<input checked="" type="checkbox"/>	<input type="checkbox"/>
	Support	S02	<input type="checkbox"/>	<input checked="" type="checkbox"/>

<b>Tested By :</b> Jose Aguirre	<b>Date of testing:</b> 01-Jan-16 - 03-Mar-16
<b>Test Result : PASS</b>	

See Appendix C for list of test equipment



Frequency (MHz)	Mode	Tx Paths	Correlated Antenna Gain (dBi)	Tx 1 Max Power (dBm)	Tx 2 Max Power (dBm)	Tx 3 Max Power (dBm)	Tx 4 Max Power (dBm)	Total Tx Channel Power (dBm)	Limit (dBm)	Margin (dB)
5745	Non HT20, 6 to 54 Mbps	1	6	15.2				15.2	30.0	14.8
	Non HT20, 6 to 54 Mbps	2	6	12.1	11.2			14.7	30.0	15.3
	Non HT20, 6 to 54 Mbps	3	6	10.2	9.3	8.6		14.2	30.0	15.8
	Non HT20, 6 to 54 Mbps	4	6	9.3	8.3	7.7	9.1	14.7	30.0	15.3
	Non HT20 Beam Forming, 6 to 54 Mbps	2	9	9.3	8.3			11.8	27.0	15.2
	Non HT20 Beam Forming, 6 to 54 Mbps	3	11	6.2	5.1	4.7		10.2	25.0	14.8
	Non HT20 Beam Forming, 6 to 54 Mbps	4	12	3.3	2.2	1.8	3.1	8.7	24.0	15.3
	HT/VHT20, M0 to M7	1	6	15.3				15.3	30.0	14.7
	HT/VHT20, M0 to M7	2	6	13.1	12.3			15.7	30.0	14.3
	HT/VHT20, M8 to M15	2	6	13.1	12.3			15.7	30.0	14.3
	HT/VHT20, M0 to M7	3	6	11.3	10.4	9.8		15.3	30.0	14.7
	HT/VHT20, M8 to M15	3	6	11.3	10.4	9.8		15.3	30.0	14.7
	HT/VHT20, M16 to M23	3	6	11.3	10.4	9.8		15.3	30.0	14.7
	HT/VHT20, M0 to M7	4	6	9.4	8.5	7.8	9.3	14.8	30.0	15.2
	HT/VHT20, M8 to M15	4	6	9.4	8.5	7.8	9.3	14.8	30.0	15.2
	HT/VHT20, M16 to M23	4	6	9.4	8.5	7.8	9.3	14.8	30.0	15.2
	HT/VHT20 Beam Forming, M0 to M7	2	9	9.4	8.5			12.0	27.0	15.0
	HT/VHT20 Beam Forming, M8 to M15	2	6	13.1	12.3			15.7	30.0	14.3
	HT/VHT20 Beam Forming, M0 to M7	3	11	6.3	5.3	4.8		10.3	25.0	14.7
	HT/VHT20 Beam Forming, M8 to M15	3	8	9.4	8.5	7.8		13.4	28.0	14.6
	HT/VHT20 Beam Forming, M16 to M23	3	6	11.3	10.4	9.8		15.3	30.0	14.7
	HT/VHT20 Beam Forming, M0 to M7	4	12	3.5	2.4	1.9	3.3	8.8	24.0	15.2
	HT/VHT20 Beam Forming, M8 to M15	4	9	6.3	5.3	4.8	6.3	11.7	27.0	15.3
	HT/VHT20 Beam Forming, M16 to M23	4	7	8.1	7.1	6.7	8.2	13.6	29.0	15.4
	HT/VHT20 STBC, M0 to M7	2	6	13.1	12.3			15.7	30.0	14.3
	HT/VHT20 STBC, M0 to M7	3	6	11.3	10.4	9.8		15.3	30.0	14.7
HT/VHT20 STBC, M0 to M7	4	6	9.4	8.5	7.8	9.3	14.8	30.0	15.2	
5755	Non HT40, 6 to 54 Mbps	1	6	6.4				6.4	30.0	23.6
	Non HT40, 6 to 54 Mbps	2	6	3.4	2.6			6.0	30.0	24.0
	Non HT40, 6 to 54 Mbps	3	6	2.4	1.4	1.0		6.4	30.0	23.6
	Non HT40, 6 to 54 Mbps	4	6	2.4	1.4	1.0	2.2	7.8	30.0	22.2
	HT/VHT40, M0 to M7	1	6	14.9				14.9	30.0	15.1
	HT/VHT40, M0 to M7	2	6	10.4	9.2			12.9	30.0	17.1



	HT/VHT40, M8 to M15	2	6	10.4	9.2			12.9	30.0	17.1
	HT/VHT40, M0 to M7	3	6	8.1	7.2	6.9		12.2	30.0	17.8
	HT/VHT40, M8 to M15	3	6	8.1	7.2	6.9		12.2	30.0	17.8
	HT/VHT40, M16 to M23	3	6	8.1	7.2	6.9		12.2	30.0	17.8
	HT/VHT40, M0 to M7	4	6	6.2	5.3	5.0	6.1	11.7	30.0	18.3
	HT/VHT40, M8 to M15	4	6	6.2	5.3	5.0	6.1	11.7	30.0	18.3
	HT/VHT40, M16 to M23	4	6	6.2	5.3	5.0	6.1	11.7	30.0	18.3
	HT/VHT40 Beam Forming, M0 to M7	2	9	8.1	7.2			10.7	27.0	16.3
	HT/VHT40 Beam Forming, M8 to M15	2	6	10.4	9.2			12.9	30.0	17.1
	HT/VHT40 Beam Forming, M0 to M7	3	11	2.2	1.3	0.8		6.2	25.0	18.8
	HT/VHT40 Beam Forming, M8 to M15	3	8	5.2	4.3	4.1		9.3	28.0	18.7
	HT/VHT40 Beam Forming, M16 to M23	3	6	8.1	7.2	6.9		12.2	30.0	17.8
	HT/VHT40 Beam Forming, M0 to M7	4	12	1.2	0.3	-0.2	1.1	6.7	24.0	17.3
	HT/VHT40 Beam Forming, M8 to M15	4	9	3.3	2.3	2.0	3.1	8.7	27.0	18.3
	HT/VHT40 Beam Forming, M16 to M23	4	7	5.2	4.3	4.1	5.1	10.7	29.0	18.3
	HT/VHT40 STBC, M0 to M7	2	6	10.4	9.2			12.9	30.0	17.1
	HT/VHT40 STBC, M0 to M7	3	6	8.1	7.2	6.9		12.2	30.0	17.8
	HT/VHT40 STBC, M0 to M7	4	6	6.2	5.3	5.0	6.1	11.7	30.0	18.3
5775	Non HT80, 6 to 54 Mbps	1	6	10.3				10.3	30.0	19.7
	Non HT80, 6 to 54 Mbps	2	6	10.3	10.1			13.2	30.0	16.8
	Non HT80, 6 to 54 Mbps	3	6	7.5	8.5	8.8		13.1	30.0	16.9
	Non HT80, 6 to 54 Mbps	4	6	7.7	7.6	7.9	8.2	13.9	30.0	16.1
	VHT80, M0.1 to M9.1	1	6	14.2				14.2	30.0	15.8
	VHT80, M0.1 to M9.1	2	6	13.0	12.8			15.9	30.0	14.1
	VHT80, M0.2 to M9.2	2	6	13.0	12.8			15.9	30.0	14.1
	VHT80, M0.1 to M9.1	3	6	13.0	12.8	13.1		17.7	30.0	12.3
	VHT80, M0.2 to M9.2	3	6	13.0	12.8	13.1		17.7	30.0	12.3
	VHT80, M0.3 to M9.3	3	6	13.0	12.8	13.1		17.7	30.0	12.3
	VHT80, M0.1 to M9.1	4	6	10.1	9.8	10.3	10.4	16.2	30.0	13.8
	VHT80, M0.2 to M9.2	4	6	10.1	9.8	10.3	10.4	16.2	30.0	13.8
	VHT80, M0.3 to M9.3	4	6	10.1	9.8	10.3	10.4	16.2	30.0	13.8
	VHT80 Beam Forming, M0.1 to M9.1	2	6	13.0	12.8			15.9	30.0	14.1
	VHT80 Beam Forming, M0.2 to M9.2	2	6	13.0	12.8			15.9	30.0	14.1
	VHT80 Beam Forming, M0.1 to M9.1	3	6	13.0	12.8	13.1		17.7	30.0	12.3
	VHT80 Beam Forming, M0.2 to M9.2	3	6	13.0	12.8	13.1		17.7	30.0	12.3
	VHT80 Beam Forming, M0.3 to M9.3	3	6	13.0	12.8	13.1		17.7	30.0	12.3
	VHT80 Beam Forming, M0.1 to M9.1	4	6	10.1	9.8	10.3	10.4	16.2	30.0	13.8
	VHT80 Beam Forming, M0.2 to M9.2	4	6	10.1	9.8	10.3	10.4	16.2	30.0	13.8
VHT80 Beam Forming, M0.3 to M9.3	4	6	10.1	9.8	10.3	10.4	16.2	30.0	13.8	
VHT80 STBC, M0.1 to M9.1	2	6	13.0	12.8			15.9	30.0	14.1	





	VHT80 STBC, M0.1 to M9.1	3	6	13.0	12.8	13.1		17.7	30.0	12.3
	VHT80 STBC, M0.1 to M9.1	4	6	10.1	9.8	10.3	10.4	16.2	30.0	13.8
5785	Non HT20, 6 to 54 Mbps	1	6	16.3				16.3	30.0	13.7
	Non HT20, 6 to 54 Mbps	2	6	16.3	16.1			19.2	30.0	10.8
	Non HT20, 6 to 54 Mbps	3	6	16.3	16.1	16.9		21.2	30.0	8.8
	Non HT20, 6 to 54 Mbps	4	6	16.3	16.1	16.9	16.6	22.5	30.0	7.5
	Non HT20 Beam Forming, 6 to 54 Mbps	2	9	16.3	16.1			19.2	27.0	7.8
	Non HT20 Beam Forming, 6 to 54 Mbps	3	11	16.3	16.1	16.9		21.2	25.0	3.8
	Non HT20 Beam Forming, 6 to 54 Mbps	4	12	16.3	16.1	16.9	16.6	22.5	24.0	1.5
	HT/VHT20, M0 to M7	1	6	16.5				16.5	30.0	13.5
	HT/VHT20, M0 to M7	2	6	16.5	16.3			19.4	30.0	10.6
	HT/VHT20, M8 to M15	2	6	16.5	16.3			19.4	30.0	10.6
	HT/VHT20, M0 to M7	3	6	16.5	16.3	17.1		21.4	30.0	8.6
	HT/VHT20, M8 to M15	3	6	16.5	16.3	17.1		21.4	30.0	8.6
	HT/VHT20, M16 to M23	3	6	16.5	16.3	17.1		21.4	30.0	8.6
	HT/VHT20, M0 to M7	4	6	16.5	16.3	17.1	16.7	22.7	30.0	7.3
	HT/VHT20, M8 to M15	4	6	16.5	16.3	17.1	16.7	22.7	30.0	7.3
	HT/VHT20, M16 to M23	4	6	16.5	16.3	17.1	16.7	22.7	30.0	7.3
	HT/VHT20 Beam Forming, M0 to M7	2	9	16.5	16.3			19.4	27.0	7.6
	HT/VHT20 Beam Forming, M8 to M15	2	6	16.5	16.3			19.4	30.0	10.6
	HT/VHT20 Beam Forming, M0 to M7	3	11	16.5	16.3	17.1		21.4	25.0	3.6
	HT/VHT20 Beam Forming, M8 to M15	3	8	16.5	16.3	17.1		21.4	28.0	6.6
	HT/VHT20 Beam Forming, M16 to M23	3	6	16.5	16.3	17.1		21.4	30.0	8.6
	HT/VHT20 Beam Forming, M0 to M7	4	12	16.5	16.3	17.1	16.7	22.7	24.0	1.3
	HT/VHT20 Beam Forming, M8 to M15	4	9	16.5	16.3	17.1	16.7	22.7	27.0	4.3
	HT/VHT20 Beam Forming, M16 to M23	4	7	16.5	16.3	17.1	16.7	22.7	29.0	6.3
HT/VHT20 STBC, M0 to M7	2	6	16.5	16.3			19.4	30.0	10.6	
HT/VHT20 STBC, M0 to M7	3	6	16.5	16.3	17.1		21.4	30.0	8.6	
HT/VHT20 STBC, M0 to M7	4	6	16.5	16.3	17.1	16.7	22.7	30.0	7.3	
5795	Non HT40, 6 to 54 Mbps	1	6	18.4				18.4	30.0	11.6
	Non HT40, 6 to 54 Mbps	2	6	16.2	15.1			18.7	30.0	11.3
	Non HT40, 6 to 54 Mbps	3	6	16.2	15.1	16.0		20.6	30.0	9.4
	Non HT40, 6 to 54 Mbps	4	6	16.2	15.1	16.0	15.7	21.8	30.0	8.2
	HT/VHT40, M0 to M7	1	6	17.0				17.0	30.0	13.0
	HT/VHT40, M0 to M7	2	6	17.0	16.2			19.6	30.0	10.4
	HT/VHT40, M8 to M15	2	6	17.0	16.2			19.6	30.0	10.4
	HT/VHT40, M0 to M7	3	6	17.0	16.2	17.2		21.6	30.0	8.4
	HT/VHT40, M8 to M15	3	6	17.0	16.2	17.2		21.6	30.0	8.4
	HT/VHT40, M16 to M23	3	6	17.0	16.2	17.2		21.6	30.0	8.4



	HT/VHT40, M0 to M7	4	6	17.0	16.2	17.2	16.8	22.8	30.0	7.2
	HT/VHT40, M8 to M15	4	6	17.0	16.2	17.2	16.8	22.8	30.0	7.2
	HT/VHT40, M16 to M23	4	6	17.0	16.2	17.2	16.8	22.8	30.0	7.2
	HT/VHT40 Beam Forming, M0 to M7	2	9	17.0	16.2			19.6	27.0	7.4
	HT/VHT40 Beam Forming, M8 to M15	2	6	17.0	16.2			19.6	30.0	10.4
	HT/VHT40 Beam Forming, M0 to M7	3	11	17.0	16.2	17.2		21.6	25.0	3.6
	HT/VHT40 Beam Forming, M8 to M15	3	8	17.0	16.2	17.2		21.6	28.0	6.4
	HT/VHT40 Beam Forming, M16 to M23	3	6	17.0	16.2	17.2		21.6	30.0	8.2
	<b>HT/VHT40 Beam Forming, M0 to M7</b>	<b>4</b>	<b>12</b>	<b>17.0</b>	<b>16.2</b>	<b>17.2</b>	<b>16.8</b>	<b>22.8</b>	<b>24.0</b>	<b>1.2</b>
	HT/VHT40 Beam Forming, M8 to M15	4	9	17.0	16.2	17.2	16.8	22.8	27.0	4.2
	HT/VHT40 Beam Forming, M16 to M23	4	7	17.0	16.2	17.2	16.8	22.8	29.0	6.2
	HT/VHT40 STBC, M0 to M7	2	6	17.0	16.2			19.6	30.0	10.4
	HT/VHT40 STBC, M0 to M7	3	6	17.0	16.2	17.2		21.6	30.0	8.4
	HT/VHT40 STBC, M0 to M7	4	6	17.0	16.2	17.2	16.8	22.8	30.0	7.2
5825	Non HT20, 6 to 54 Mbps	1	6	15.0				15.0	30.0	15.0
	Non HT20, 6 to 54 Mbps	2	6	12.6	13.0			15.8	30.0	14.2
	Non HT20, 6 to 54 Mbps	3	6	10.7	11.1	11.4		15.8	30.0	14.2
	Non HT20, 6 to 54 Mbps	4	6	9.8	10.0	10.5	10.4	16.2	30.0	13.8
	Non HT20 Beam Forming, 6 to 54 Mbps	2	9	9.8	10.0			12.9	27.0	14.1
	Non HT20 Beam Forming, 6 to 54 Mbps	3	11	5.6	5.8	6.3		10.7	25.0	14.3
	Non HT20 Beam Forming, 6 to 54 Mbps	4	12	2.7	2.9	3.3	3.4	9.1	24.0	14.9
	HT/VHT20, M0 to M7	1	6	16.2				16.2	30.0	13.8
	HT/VHT20, M0 to M7	2	6	12.7	13.1			15.9	30.0	14.1
	HT/VHT20, M8 to M15	2	6	12.7	13.1			15.9	30.0	14.1
	HT/VHT20, M0 to M7	3	6	10.7	11.2	11.5		15.9	30.0	14.1
	HT/VHT20, M8 to M15	3	6	10.7	11.2	11.5		15.9	30.0	14.1
	HT/VHT20, M16 to M23	3	6	10.7	11.2	11.5		15.9	30.0	14.1
	HT/VHT20, M0 to M7	4	6	9.8	10.1	10.6	10.4	16.3	30.0	13.7
	HT/VHT20, M8 to M15	4	6	9.8	10.1	10.6	10.4	16.3	30.0	13.7
	HT/VHT20, M16 to M23	4	6	9.8	10.1	10.6	10.4	16.3	30.0	13.7
	HT/VHT20 Beam Forming, M0 to M7	2	9	8.9	9.1			12.0	27.0	15.0
	HT/VHT20 Beam Forming, M8 to M15	2	6	12.7	13.1			15.9	30.0	14.1
	HT/VHT20 Beam Forming, M0 to M7	3	11	6.6	6.9	7.4		11.8	25.0	13.2
	HT/VHT20 Beam Forming, M8 to M15	3	8	8.9	9.1	9.4		13.9	28.0	14.1
	HT/VHT20 Beam Forming, M16 to M23	3	6	10.7	11.2	11.5		15.9	30.0	14.1
	HT/VHT20 Beam Forming, M0 to M7	4	12	3.7	4.1	4.6	4.4	10.2	24.0	13.8
	HT/VHT20 Beam Forming, M8 to M15	4	9	6.6	6.9	7.4	7.4	13.1	27.0	13.9
	HT/VHT20 Beam Forming, M16 to M23	4	7	8.9	9.1	9.4	9.4	15.2	29.0	13.8
	HT/VHT20 STBC, M0 to M7	2	6	12.7	13.1			15.9	30.0	14.1
	HT/VHT20 STBC, M0 to M7	3	6	10.7	11.2	11.5		15.9	30.0	14.1



HT/VHT20 STBC, M0 to M7	4	6	9.8	10.1	10.6	10.4	16.3	30.0	13.7
-------------------------	---	---	-----	------	------	------	------	------	------

**Peak Output Power, 5795 MHz, HT/VHT40 Beam Forming, M0 to M7**

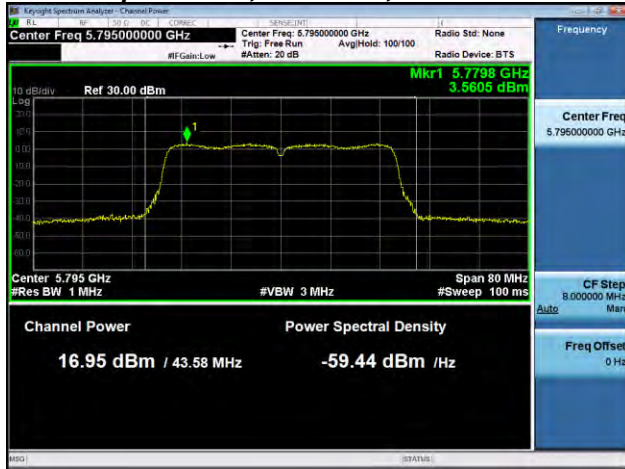

**Antenna A**

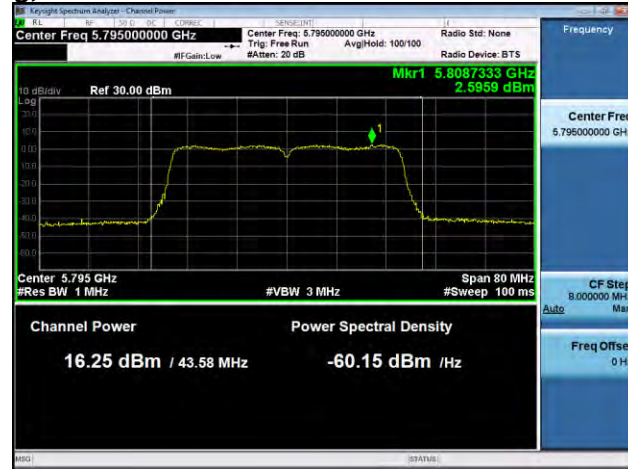

**Antenna B**

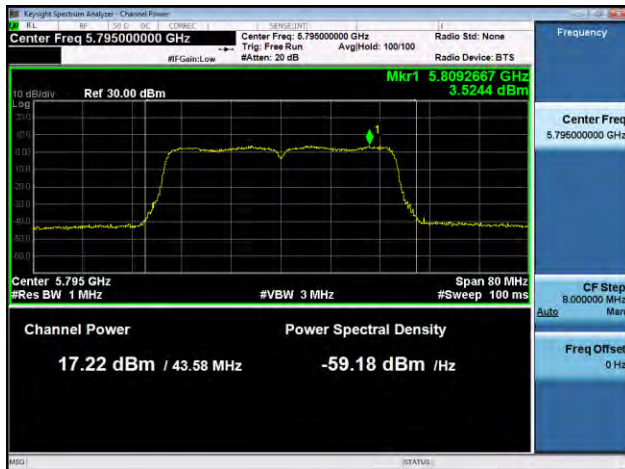

**Antenna C**

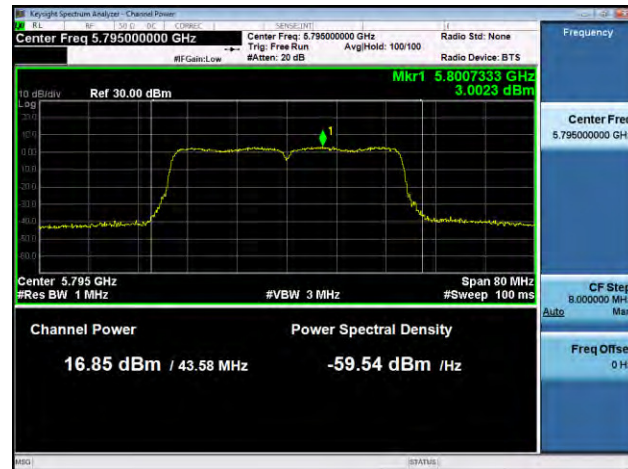

**Antenna D**



## A.4 Power Spectral Density

### 15.407

The power spectral density shall not exceed 30 dBm in any 500 kHz band. If transmitting antennas of directional gain greater than 6 dBi are used, both the maximum conducted output power and the power spectral density shall be reduced by the amount in dB that the directional gain of the antenna exceeds 6 dBi.

### Test Procedure

Ref. KDB 789033 D02 General UNII Test Procedures New Rules v01r01

<b>Power Spectral Density</b> Test Procedure
1. Connect the antenna port(s) to the spectrum analyzer input. 2. Set the radio in the continuous transmitting mode at full power 3. Configure Spectrum analyzer as per test parameters below and Peak search marker 4. Capture graphs and record pertinent measurement data.

Ref. KDB 789033 D02 v01r01 section F.5

<b>Power Spectral Density</b> Test parameters
Span = >1.5 times the OBW RBW = 500 kHz. VBW ≥ 3 x RBW Sweep = 10s Detector = Peak Trace = Single Sweep Marker = Peak Search

The “Measure and add 10 log(N) dB technique”, where N is the number of outputs, is used for measuring in-band Power Spectral Density. With this technique, spectrum measurements are performed at each output of the device, and the quantity 10 log(4) (or 6dB) is added to the worst case spectrum value before comparing to the emission limit. (ANSI C63.10 2013 section 14.3.2.3)

System Number	Description	Samples	System under test	Support equipment
1	EUT	S01	<input checked="" type="checkbox"/>	<input type="checkbox"/>
	Support	S02	<input type="checkbox"/>	<input checked="" type="checkbox"/>

<b>Tested By :</b> Jose Aguirre	<b>Date of testing:</b> 01-Jan-16 - 03-Mar-16
<b>Test Result : PASS</b>	

See Appendix C for list of test equipment



Frequency (MHz)	Mode	Tx Paths	Correlated Antenna Gain (dBi)	Tx 1 PSD (dBm/MHz)	Tx 2 PSD (dBm/MHz)	Tx 3 PSD (dBm/MHz)	Tx 4 PSD (dBm/MHz)	Total PSD (dBm/500MHz)	Limit (dBm/500MHz)	Margin (dB)
5745	Non HT20, 6 to 54 Mbps	1	6	2.0				2.0	30.0	28.0
	Non HT20, 6 to 54 Mbps	2	9	-1.5	-2.2			1.2	27.0	25.8
	Non HT20, 6 to 54 Mbps	3	11	-3.2	-4.2	-4.8		0.8	25.0	24.3
	Non HT20, 6 to 54 Mbps	4	12	-4.3	-5.1	-5.9	-4.0	1.3	24.0	22.7
	Non HT20 Beam Forming, 6 to 54 Mbps	2	9	-4.3	-5.1			-1.7	27.0	28.7
	Non HT20 Beam Forming, 6 to 54 Mbps	3	11	-6.9	-8.4	-8.7		-3.2	25.0	28.2
	Non HT20 Beam Forming, 6 to 54 Mbps	4	12	-10.3	-11.3	-11.8	-10.4	-4.9	24.0	28.9
	HT/VHT20, M0 to M7	1	6	1.7				1.7	30.0	28.3
	HT/VHT20, M0 to M7	2	9	-0.6	-1.4			2.0	27.0	25.0
	HT/VHT20, M8 to M15	2	6	-0.6	-1.4			2.0	30.0	28.0
	HT/VHT20, M0 to M7	3	11	-2.4	-3.4	-3.9		1.6	25.0	23.4
	HT/VHT20, M8 to M15	3	8	-2.4	-3.4	-3.9		1.6	28.0	26.4
	HT/VHT20, M16 to M23	3	6	-2.4	-3.4	-3.9		1.6	30.0	28.4
	HT/VHT20, M0 to M7	4	12	-4.3	-5.3	-5.8	-4.2	1.2	24.0	22.8
	HT/VHT20, M8 to M15	4	9	-4.3	-5.3	-5.8	-4.2	1.2	27.0	25.8
	HT/VHT20, M16 to M23	4	7	-4.3	-5.3	-5.8	-4.2	1.2	29.0	27.8
	HT/VHT20 Beam Forming, M0 to M7	2	9	-4.3	-5.3			-1.8	27.0	28.8
	HT/VHT20 Beam Forming, M8 to M15	2	6	-0.6	-1.4			2.0	30.0	28.0
	HT/VHT20 Beam Forming, M0 to M7	3	11	-7.4	-8.5	-9.0		-3.5	25.0	28.5
	HT/VHT20 Beam Forming, M8 to M15	3	8	-4.3	-5.3	-5.8		-0.3	28.0	28.4
	HT/VHT20 Beam Forming, M16 to M23	3	6	-2.4	-3.4	-3.9		1.6	30.0	28.4
	HT/VHT20 Beam Forming, M0 to M7	4	12	-9.7	-11.4	-12.0	-10.3	-4.7	24.0	28.7
	HT/VHT20 Beam Forming, M8 to M15	4	9	-7.4	-8.5	-9.0	-7.4	-2.0	27.0	29.0
	HT/VHT20 Beam Forming, M16 to M23	4	7	-5.2	-6.7	-6.6	-5.6	0.0	28.8	28.7
	HT/VHT20 STBC, M0 to M7	2	6	-0.6	-1.4			2.0	30.0	28.0
	HT/VHT20 STBC, M0 to M7	3	8	-2.4	-3.4	-3.9		1.6	28.0	26.5
	HT/VHT20 STBC, M0 to M7	4	9	-4.3	-5.3	-5.8	-4.2	1.2	27.0	25.8
	5755	Non HT40, 6 to 54 Mbps	1	6	-9.7				-9.7	30.0
Non HT40, 6 to 54 Mbps		2	9	-12.8	-13.7			-10.2	27.0	37.2
Non HT40, 6 to 54 Mbps		3	11	-13.7	-15.1	-15.3		-9.9	25.0	34.9
Non HT40, 6 to 54 Mbps		4	12	-13.7	-15.1	-15.3	-13.7	-8.4	24.0	32.3
HT/VHT40, M0 to M7		1	6	-1.8				-1.8	30.0	31.8
HT/VHT40, M0 to M7		2	9	-6.0	-7.3			-3.6	27.0	30.6



	HT/VHT40, M8 to M15	2	6	-6.0	-7.3			-3.6	30.0	33.6
	HT/VHT40, M0 to M7	3	11	-8.1	-9.5	-9.4		-4.2	25.0	29.2
	HT/VHT40, M8 to M15	3	8	-8.1	-9.5	-9.4		-4.2	28.0	32.2
	HT/VHT40, M16 to M23	3	6	-8.1	-9.5	-9.4		-4.2	30.0	34.2
	HT/VHT40, M0 to M7	4	12	-10.2	-11.5	-11.5	-10.2	-4.8	24.0	28.8
	HT/VHT40, M8 to M15	4	9	-10.2	-11.5	-11.5	-10.2	-4.8	27.0	31.8
	HT/VHT40, M16 to M23	4	7	-10.2	-11.5	-11.5	-10.2	-4.8	29.0	33.8
	HT/VHT40 Beam Forming, M0 to M7	2	9	-8.1	-9.5			-5.7	27.0	32.7
	HT/VHT40 Beam Forming, M8 to M15	2	6	-6.0	-7.3			-3.6	30.0	33.6
	HT/VHT40 Beam Forming, M0 to M7	3	11	-14.5	-15.5	-15.9		-10.5	25.0	35.5
	HT/VHT40 Beam Forming, M8 to M15	3	8	-10.5	-12.4	-12.6		-7.0	28.0	35.0
	HT/VHT40 Beam Forming, M16 to M23	3	6	-8.1	-9.5	-9.4		-4.2	30.0	34.2
	HT/VHT40 Beam Forming, M0 to M7	4	12	-15.4	-16.6	-17.0	-15.3	-10.0	24.0	34.0
	HT/VHT40 Beam Forming, M8 to M15	4	9	-13.1	-14.6	-14.6	-12.9	-7.7	27.0	34.7
	HT/VHT40 Beam Forming, M16 to M23	4	7	-10.5	-12.4	-12.6	-11.1	-5.5	29.0	34.1
	HT/VHT40 STBC, M0 to M7	2	6	-6.0	-7.3			-3.6	30.0	33.6
	HT/VHT40 STBC, M0 to M7	3	8	-8.1	-9.5	-9.4		-4.2	28.0	32.0
	HT/VHT40 STBC, M0 to M7	4	9	-10.2	-11.5	-11.5	-10.2	-4.8	27.0	31.8
5775	Non HT80, 6 to 54 Mbps	1	6	-9.1				-9.1	30.0	39.1
	Non HT80, 6 to 54 Mbps	2	9	-9.1	-9.5			-6.3	27.0	33.3
	Non HT80, 6 to 54 Mbps	3	11	-11.9	-11.3	-10.7		-6.5	25.0	31.5
	Non HT80, 6 to 54 Mbps	4	12	-11.3	-12.1	-11.6	-11.4	-5.6	24.0	29.5
	VHT80, M0.1 to M9.1	1	6	-5.5				-5.5	30.0	35.5
	VHT80, M0.1 to M9.1	2	6	-6.9	-7.5			-4.2	30.0	34.2
	VHT80, M0.2 to M9.2	2	6	-6.9	-7.5			-4.2	30.0	34.2
	VHT80, M0.1 to M9.1	3	6	-6.9	-7.5	-6.7		-2.2	30.0	32.2
	VHT80, M0.2 to M9.2	3	6	-6.9	-7.5	-6.7		-2.2	30.0	32.2
	VHT80, M0.3 to M9.3	3	6	-6.9	-7.5	-6.7		-2.2	30.0	32.2
	VHT80, M0.1 to M9.1	4	6	-9.6	-10.6	-9.6	-9.7	-3.8	30.0	33.8
	VHT80, M0.2 to M9.2	4	6	-9.6	-10.6	-9.6	-9.7	-3.8	30.0	33.8
	VHT80, M0.3 to M9.3	4	6	-9.6	-10.6	-9.6	-9.7	-3.8	30.0	33.8
	VHT80 Beam Forming, M0.1 to M9.1	2	6	-6.9	-7.5			-4.2	30.0	34.2
	VHT80 Beam Forming, M0.2 to M9.2	2	6	-6.9	-7.5			-4.2	30.0	34.2
	VHT80 Beam Forming, M0.1 to M9.1	3	6	-6.9	-7.5	-6.7		-2.2	30.0	32.2
	VHT80 Beam Forming, M0.2 to M9.2	3	6	-6.9	-7.5	-6.7		-2.2	30.0	32.2
	VHT80 Beam Forming, M0.3 to M9.3	3	6	-6.9	-7.5	-6.7		-2.2	30.0	32.2
	VHT80 Beam Forming, M0.1 to M9.1	4	6	-9.6	-10.6	-9.6	-9.7	-3.8	30.0	33.8
	VHT80 Beam Forming, M0.2 to M9.2	4	6	-9.6	-10.6	-9.6	-9.7	-3.8	30.0	33.8
VHT80 Beam Forming, M0.3 to M9.3	4	6	-9.6	-10.6	-9.6	-9.7	-3.8	30.0	33.8	
VHT80 STBC, M0.1 to M9.1	2	6	-6.9	-7.5			-4.2	30.0	34.2	



	VHT80 STBC, M0.1 to M9.1	3	6	-6.9	-7.5	-6.7		-2.2	30.0	32.2
	VHT80 STBC, M0.1 to M9.1	4	6	-9.6	-10.6	-9.6	-9.7	-3.8	30.0	33.8
5785	Non HT20, 6 to 54 Mbps	1	6	2.9				2.9	30.0	27.1
	Non HT20, 6 to 54 Mbps	2	9	2.9	2.5			5.7	27.0	21.3
	Non HT20, 6 to 54 Mbps	3	11	2.9	2.5	3.6		7.8	25.0	17.2
	Non HT20, 6 to 54 Mbps	4	12	2.9	2.5	3.6	3.0	9.0	24.0	14.9
	Non HT20 Beam Forming, 6 to 54 Mbps	2	9	2.9	2.5			5.7	27.0	21.3
	Non HT20 Beam Forming, 6 to 54 Mbps	3	11	2.9	2.5	3.6		7.8	25.0	17.2
	Non HT20 Beam Forming, 6 to 54 Mbps	4	12	2.9	2.5	3.6	3.0	9.0	24.0	14.9
	HT/VHT20, M0 to M7	1	6	3.0				3.0	30.0	27.0
	HT/VHT20, M0 to M7	2	9	3.0	2.5			5.8	27.0	21.2
	HT/VHT20, M8 to M15	2	6	3.0	2.5			5.8	30.0	24.2
	HT/VHT20, M0 to M7	3	11	3.0	2.5	3.5		7.8	25.0	17.2
	HT/VHT20, M8 to M15	3	8	3.0	2.5	3.5		7.8	28.0	20.2
	HT/VHT20, M16 to M23	3	6	3.0	2.5	3.5		7.8	30.0	22.2
	<b>HT/VHT20, M0 to M7</b>	<b>4</b>	<b>12</b>	<b>3.0</b>	<b>2.5</b>	<b>3.5</b>	<b>3.1</b>	<b>9.1</b>	<b>24.0</b>	<b>14.9</b>
	HT/VHT20, M8 to M15	4	9	3.0	2.5	3.5	3.1	9.1	27.0	17.9
	HT/VHT20, M16 to M23	4	7	3.0	2.5	3.5	3.1	9.1	29.0	19.9
	HT/VHT20 Beam Forming, M0 to M7	2	9	3.0	2.5			5.8	27.0	21.2
	HT/VHT20 Beam Forming, M8 to M15	2	6	3.0	2.5			5.8	30.0	24.2
	HT/VHT20 Beam Forming, M0 to M7	3	11	3.0	2.5	3.5		7.8	25.0	17.2
	HT/VHT20 Beam Forming, M8 to M15	3	8	3.0	2.5	3.5		7.8	28.0	20.2
	HT/VHT20 Beam Forming, M16 to M23	3	6	3.0	2.5	3.5		7.8	30.0	22.2
	HT/VHT20 Beam Forming, M0 to M7	4	12	3.0	2.5	3.5	3.1	9.1	24.0	14.9
	HT/VHT20 Beam Forming, M8 to M15	4	9	3.0	2.5	3.5	3.1	9.1	27.0	17.9
	HT/VHT20 Beam Forming, M16 to M23	4	7	3.0	2.5	3.5	3.1	9.1	29.0	19.9
	HT/VHT20 STBC, M0 to M7	2	6	3.0	2.5			5.8	30.0	24.2
	HT/VHT20 STBC, M0 to M7	3	8	3.0	2.5	3.5		7.8	28.0	20.2
HT/VHT20 STBC, M0 to M7	4	9	3.0	2.5	3.5	3.1	9.1	27.0	17.9	
5795	Non HT40, 6 to 54 Mbps	1	6	1.8				1.8	30.0	28.2
	Non HT40, 6 to 54 Mbps	2	9	-0.1	-1.4			2.3	27.0	24.7
	Non HT40, 6 to 54 Mbps	3	11	-0.1	-1.4	-0.3		4.2	25.0	20.8
	Non HT40, 6 to 54 Mbps	4	12	-0.1	-1.4	-0.3	-0.7	5.4	24.0	18.6
	HT/VHT40, M0 to M7	1	6	0.4				0.4	30.0	29.6
	HT/VHT40, M0 to M7	2	9	0.4	-0.5			3.0	27.0	24.0
	HT/VHT40, M8 to M15	2	6	0.4	-0.5			3.0	30.0	27.0
	HT/VHT40, M0 to M7	3	11	0.4	-0.5	0.6		5.0	25.0	20.1
	HT/VHT40, M8 to M15	3	8	0.4	-0.5	0.6		5.0	28.0	23.1
	HT/VHT40, M16 to M23	3	6	0.4	-0.5	0.6		5.0	30.0	25.0



	HT/VHT40, M0 to M7	4	12	0.4	-0.5	0.6	0.1	6.2	24.0	17.8
	HT/VHT40, M8 to M15	4	9	0.4	-0.5	0.6	0.1	6.2	27.0	20.8
	HT/VHT40, M16 to M23	4	7	0.4	-0.5	0.6	0.1	6.2	29.0	22.8
	HT/VHT40 Beam Forming, M0 to M7	2	9	0.4	-0.5			3.0	27.0	24.0
	HT/VHT40 Beam Forming, M8 to M15	2	6	0.4	-0.5			3.0	30.0	27.0
	HT/VHT40 Beam Forming, M0 to M7	3	11	0.4	-0.5	0.6		5.0	25.0	20.0
	HT/VHT40 Beam Forming, M8 to M15	3	8	0.4	-0.5	0.6		5.0	28.0	23.0
	HT/VHT40 Beam Forming, M16 to M23	3	6	0.4	-0.5	0.6		5.0	30.0	25.0
	HT/VHT40 Beam Forming, M0 to M7	4	12	0.4	-0.5	0.6	0.1	6.2	24.0	17.8
	HT/VHT40 Beam Forming, M8 to M15	4	9	0.4	-0.5	0.6	0.1	6.2	27.0	20.8
	HT/VHT40 Beam Forming, M16 to M23	4	7	0.4	-0.5	0.6	0.1	6.2	29.0	22.8
	HT/VHT40 STBC, M0 to M7	2	6	0.4	-0.5			3.0	30.0	27.0
	HT/VHT40 STBC, M0 to M7	3	8	0.4	-0.5	0.6		5.0	28.0	23.0
	HT/VHT40 STBC, M0 to M7	4	9	0.4	-0.5	0.6	0.1	6.2	27.0	20.8
5825	Non HT20, 6 to 54 Mbps	1	6	1.9				1.9	30.0	28.1
	Non HT20, 6 to 54 Mbps	2	9	-0.8	-0.4			2.4	27.0	24.6
	Non HT20, 6 to 54 Mbps	3	11	-2.7	-2.4	-2.0		2.4	25.0	22.6
	Non HT20, 6 to 54 Mbps	4	12	-3.7	-3.4	-3.0	-3.1	2.7	24.0	21.3
	Non HT20 Beam Forming, 6 to 54 Mbps	2	9	-3.7	-3.4			-0.5	27.0	27.5
	Non HT20 Beam Forming, 6 to 54 Mbps	3	11	-7.7	-7.7	-6.8		-2.6	25.0	27.6
	Non HT20 Beam Forming, 6 to 54 Mbps	4	12	-10.8	-10.6	-10.2	-10.3	-4.4	24.0	28.4
	HT/VHT20, M0 to M7	1	6	2.7				2.7	30.0	27.3
	HT/VHT20, M0 to M7	2	9	-1.1	-0.7			2.1	27.0	24.9
	HT/VHT20, M8 to M15	2	6	-1.1	-0.7			2.1	30.0	27.9
	HT/VHT20, M0 to M7	3	11	-2.9	-2.2	-2.1		2.4	25.0	22.6
	HT/VHT20, M8 to M15	3	8	-2.9	-2.2	-2.1		2.4	28.0	25.7
	HT/VHT20, M16 to M23	3	6	-2.9	-2.2	-2.1		2.4	30.0	27.6
	HT/VHT20, M0 to M7	4	12	-3.9	-3.2	-2.7	-3.3	2.8	24.0	21.2
	HT/VHT20, M8 to M15	4	9	-3.9	-3.2	-2.7	-3.3	2.8	27.0	24.2
	HT/VHT20, M16 to M23	4	7	-3.9	-3.2	-2.7	-3.3	2.8	29.0	26.2
	HT/VHT20 Beam Forming, M0 to M7	2	9	-4.7	-4.7			-1.7	27.0	28.7
	HT/VHT20 Beam Forming, M8 to M15	2	6	-1.1	-0.7			2.1	30.0	27.9
	HT/VHT20 Beam Forming, M0 to M7	3	11	-7.1	-6.8	-6.2		-1.9	25.0	26.9
	HT/VHT20 Beam Forming, M8 to M15	3	8	-4.7	-4.7	-3.9		0.4	28.0	27.6
	HT/VHT20 Beam Forming, M16 to M23	3	6	-2.9	-2.2	-2.1		2.4	30.0	27.6
	HT/VHT20 Beam Forming, M0 to M7	4	12	-9.5	-9.5	-8.4	-9.2	-3.1	24.0	27.1
	HT/VHT20 Beam Forming, M8 to M15	4	9	-7.1	-6.8	-6.2	-6.3	-0.6	27.0	27.6
	HT/VHT20 Beam Forming, M16 to M23	4	7	-4.7	-4.7	-3.9	-4.0	1.7	29.0	27.3
	HT/VHT20 STBC, M0 to M7	2	6	-1.1	-0.7			2.1	30.0	27.9
HT/VHT20 STBC, M0 to M7	3	8	-2.9	-2.2	-2.1		2.4	28.0	25.7	





HT/VHT20 STBC, M0 to M7	4	9	-3.9	-3.2	-2.7	-3.3	2.8	27.0	24.2
-------------------------	---	---	------	------	------	------	-----	------	------

**Power Spectral Density, 5785 MHz, HT/VHT20 Beam Forming, M0 to M7**

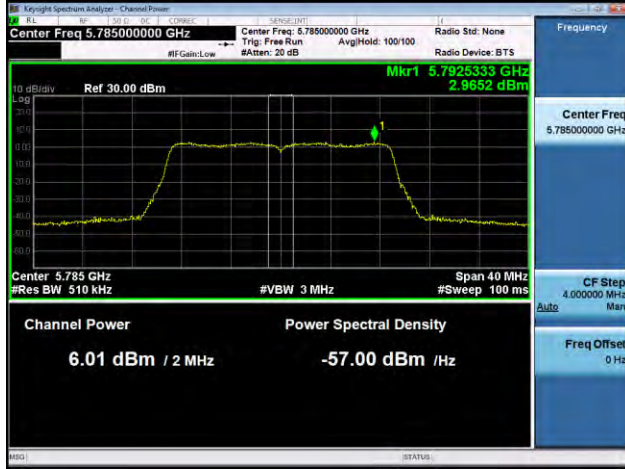

**Antenna A**

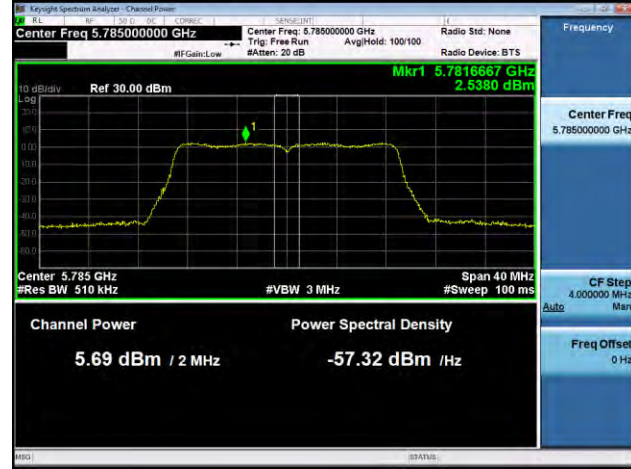

**Antenna B**

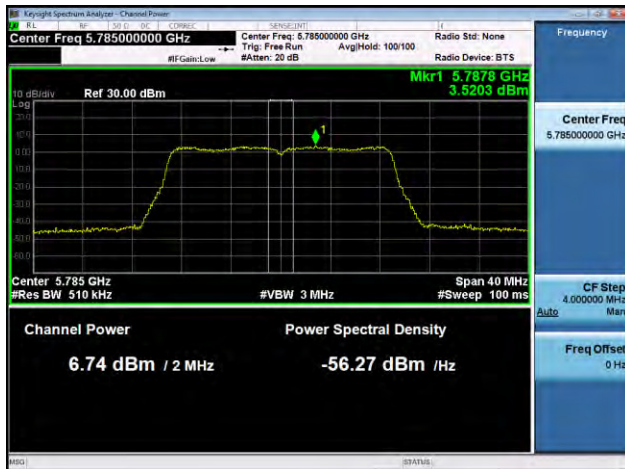

**Antenna C**

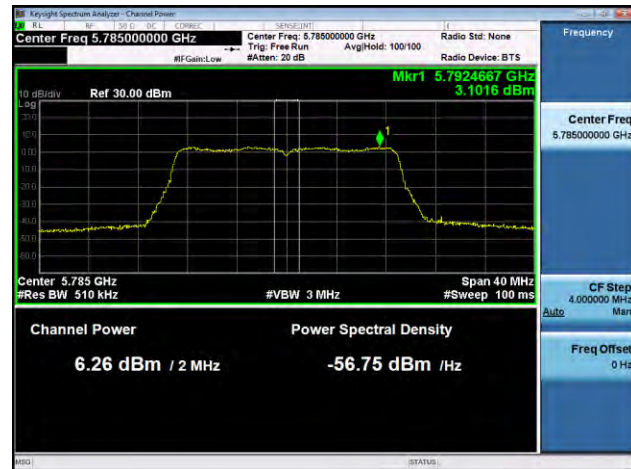

**Antenna D**



## A.5 Conducted Spurious Emissions

**15.407** (b) *Undesirable emission limits.* Except as shown in paragraph (b) (7) of this section, the maximum emissions outside of the frequency bands of operation shall be attenuated in accordance with the following limits:

(4) For transmitters operating in the 5.725-5.85 GHz band: All emissions within the frequency range from the band edge to 10 MHz above or below the band edge shall not exceed an e.i.r.p. of -17 dBm/MHz; for frequencies 10 MHz or greater above or below the band edge, emissions shall not exceed an e.i.r.p. of -27 dBm/MHz.

(6) Unwanted emissions below 1 GHz must comply with the general field strength limits set forth in §15.209.

(7) The provisions of §15.205 apply to intentional radiators operating under this section.

### Test Procedure

Ref. KDB 789033 D02 General UNII Test Procedures New Rules v01r01  
ANSI C63.10: 2013

Conducted Spurious Emissions
Test Procedure
<ol style="list-style-type: none"> <li>1. Connect the antenna port(s) to the spectrum analyzer input.</li> <li>2. Place the radio in continuous transmit mode. Use the procedures in KDB 789033 D02 General UNII Test Procedures New Rules v01 to substitute conducted measurements in place of radiated measurements.</li> <li>3. Configure Spectrum analyzer as per test parameters below (be sure to enter all losses between the transmitter output and the spectrum analyzer).</li> <li>4. Record the marker waveform peak to spur difference. Also measure any emissions in the restricted bands.</li> <li>5. The "measure-and-sum technique" is used for measuring in-band transmit power of a device. In the measure-and-sum approach, the conducted emission level is measured at each antenna port. The measured results at the various antenna ports are then summed mathematically to determine the total emission level from the device. Summing is performed in linear power units. The worst case output is recorded.</li> <li>6. Capture graphs and record pertinent measurement data.</li> </ol>

Ref. KDB 789033 D02 General UNII Test Procedures New Rules v01r01  
ANSI C63.10: 2013 section 12.7.7.3 (average) & 12.7.6 (peak)

Conducted Spurious Emissions
Test parameters
Span = 30MHz to 18GHz / 18GHz to 40GHz RBW = 1 MHz VBW ≥ 3 x RBW for Peak, 1kHz for Average Sweep = Auto couple Detector = Peak Trace = Max Hold.



System Number	Description	Samples	System under test	Support equipment
1	EUT	S01	<input checked="" type="checkbox"/>	<input type="checkbox"/>
	Support	S02	<input type="checkbox"/>	<input checked="" type="checkbox"/>

<b>Tested By :</b> Jose Aguirre	<b>Date of testing:</b> 01-Jan-16 - 03-Mar-16
<b>Test Result : PASS</b>	

See Appendix C for list of test equipment



Frequency (MHz)	Mode	Tx Paths	Correlated Antenna Gain (dBi)	Tx 1 Spur Power (dBm)	Tx 2 Spur Power (dBm)	Tx 3 Spur Power (dBm)	Tx 4 Spur Power (dBm)	Total Conducted Spur (dBm)	Limit (dBm)	Margin (dB)
5745	Non HT20, 6 to 54 Mbps	1	6	-68.2				-62.2	-41.25	21.0
	Non HT20, 6 to 54 Mbps	2	6	-68.2	-68.5			-59.3	-41.25	18.1
	Non HT20, 6 to 54 Mbps	3	6	-68.2	-68.5	-68.2		-57.5	-41.25	16.3
	Non HT20, 6 to 54 Mbps	4	6	-68.2	-68.5	-68.2	-68.9	-56.4	-41.25	15.2
	Non HT20 Beam Forming, 6 to 54 Mbps	2	9	-68.2	-68.5			-56.3	-41.25	15.1
	Non HT20 Beam Forming, 6 to 54 Mbps	3	11	-68.2	-68.5	-68.2		-52.7	-41.25	11.5
	Non HT20 Beam Forming, 6 to 54 Mbps	4	12	-68.2	-68.5	-68.2	-68.9	-50.4	-41.25	9.2
	HT/VHT20, M0 to M7	1	6	-66.7				-60.7	-41.25	19.5
	HT/VHT20, M0 to M7	2	6	-66.7	-68.5			-58.5	-41.25	17.2
	HT/VHT20, M8 to M15	2	6	-66.7	-68.5			-58.5	-41.25	17.2
	HT/VHT20, M0 to M7	3	6	-66.7	-68.5	-68.2		-57.0	-41.25	15.7
	HT/VHT20, M8 to M15	3	6	-66.7	-68.5	-68.2		-57.0	-41.25	15.7
	HT/VHT20, M16 to M23	3	6	-66.7	-68.5	-68.2		-57.0	-41.25	15.7
	HT/VHT20, M0 to M7	4	6	-66.7	-68.5	-68.2	-68.8	-56.0	-41.25	14.7
	HT/VHT20, M8 to M15	4	6	-66.7	-68.5	-68.2	-68.8	-56.0	-41.25	14.7
	HT/VHT20, M16 to M23	4	6	-66.7	-68.5	-68.2	-68.8	-56.0	-41.25	14.7
	HT/VHT20 Beam Forming, M0 to M7	2	9	-66.7	-68.5			-55.5	-41.25	14.2
	HT/VHT20 Beam Forming, M8 to M15	2	6	-66.7	-68.5			-58.5	-41.25	17.2
	HT/VHT20 Beam Forming, M0 to M7	3	11	-66.7	-68.5	-68.2		-52.2	-41.25	10.9
	HT/VHT20 Beam Forming, M8 to M15	3	8	-66.7	-68.5	-68.2		-55.2	-41.25	13.9
	HT/VHT20 Beam Forming, M16 to M23	3	6	-66.7	-68.5	-68.2		-57.0	-41.25	15.7
	HT/VHT20 Beam Forming, M0 to M7	4	12	-66.7	-68.5	-68.2	-68.8	-50.0	-41.25	8.7
	HT/VHT20 Beam Forming, M8 to M15	4	9	-66.7	-68.5	-68.2	-68.8	-53.0	-41.25	11.7
	HT/VHT20 Beam Forming, M16 to M23	4	7	-66.7	-68.5	-68.2	-68.8	-54.8	-41.25	13.5
	HT/VHT20 STBC, M0 to M7	2	6	-66.7	-68.5			-58.5	-41.25	17.2
	HT/VHT20 STBC, M0 to M7	3	6	-66.7	-68.5	-68.2		-57.0	-41.25	15.7
HT/VHT20 STBC, M0 to M7	4	6	-66.7	-68.5	-68.2	-68.8	-56.0	-41.25	14.7	
5755	Non HT40, 6 to 54 Mbps	1	6	-66.9				-60.9	-41.25	19.7
	Non HT40, 6 to 54 Mbps	2	6	-66.9	-68.3			-58.5	-41.25	17.3
	Non HT40, 6 to 54 Mbps	3	6	-66.9	-68.3	-68.5		-57.1	-41.25	15.8
	Non HT40, 6 to 54 Mbps	4	6	-66.9	-68.3	-68.5	-68.9	-56.1	-41.25	14.8
	HT/VHT40, M0 to M7	1	6	-68.7				-62.7	-41.25	21.5
	HT/VHT40, M0 to M7	2	6	-68.7	-68.9			-59.8	-41.25	18.5



	HT/VHT40, M8 to M15	2	6	-68.7	-68.9			-59.8	-41.25	18.5
	HT/VHT40, M0 to M7	3	6	-68.7	-68.9	-68.7		-58.0	-41.25	16.7
	HT/VHT40, M8 to M15	3	6	-68.7	-68.9	-68.7		-58.0	-41.25	16.7
	HT/VHT40, M16 to M23	3	6	-68.7	-68.9	-68.7		-58.0	-41.25	16.7
	HT/VHT40, M0 to M7	4	6	-68.7	-68.9	-68.7	-69.1	-56.8	-41.25	15.6
	HT/VHT40, M8 to M15	4	6	-68.7	-68.9	-68.7	-69.1	-56.8	-41.25	15.6
	HT/VHT40, M16 to M23	4	6	-68.7	-68.9	-68.7	-69.1	-56.8	-41.25	15.6
	HT/VHT40 Beam Forming, M0 to M7	2	9	-68.7	-68.9			-56.8	-41.25	15.5
	HT/VHT40 Beam Forming, M8 to M15	2	6	-68.7	-68.9			-59.8	-41.25	18.5
	HT/VHT40 Beam Forming, M0 to M7	3	11	-68.7	-68.9	-68.7		-53.2	-41.25	11.9
	HT/VHT40 Beam Forming, M8 to M15	3	8	-68.7	-68.9	-68.7		-56.2	-41.25	14.9
	HT/VHT40 Beam Forming, M16 to M23	3	6	-68.7	-68.9	-68.7		-58.0	-41.25	16.7
	HT/VHT40 Beam Forming, M0 to M7	4	12	-68.7	-68.9	-68.7	-69.1	-50.8	-41.25	9.6
	HT/VHT40 Beam Forming, M8 to M15	4	9	-68.7	-68.9	-68.7	-69.1	-53.8	-41.25	12.6
	HT/VHT40 Beam Forming, M16 to M23	4	7	-68.7	-68.9	-68.7	-69.1	-55.6	-41.25	14.4
	HT/VHT40 STBC, M0 to M7	2	6	-68.7	-68.9			-59.8	-41.25	18.5
	HT/VHT40 STBC, M0 to M7	3	6	-68.7	-68.9	-68.7		-58.0	-41.25	16.7
	HT/VHT40 STBC, M0 to M7	4	6	-68.7	-68.9	-68.7	-69.1	-56.8	-41.25	15.6
5775	Non HT80, 6 to 54 Mbps	1	6	-68.9				-62.9	-41.25	21.7
	Non HT80, 6 to 54 Mbps	2	6	-68.9	-69.1			-60.0	-41.25	18.7
	Non HT80, 6 to 54 Mbps	3	6	-68.9	-69.1	-69.0		-58.2	-41.25	17.0
	Non HT80, 6 to 54 Mbps	4	6	-68.9	-69.1	-69.0	-69.2	-57.0	-41.25	15.8
	VHT80, M0.1 to M9.1	1	6	-69.1				-63.1	-41.25	21.9
	VHT80, M0.1 to M9.1	2	6	-69.1	-69.0			-60.0	-41.25	18.8
	VHT80, M0.2 to M9.2	2	6	-69.1	-69.0			-60.0	-41.25	18.8
	VHT80, M0.1 to M9.1	3	6	-69.1	-69.0	-66.8		-57.4	-41.25	16.1
	VHT80, M0.2 to M9.2	3	6	-69.1	-69.0	-66.8		-57.4	-41.25	16.1
	VHT80, M0.3 to M9.3	3	6	-69.1	-69.0	-66.8		-57.4	-41.25	16.1
	VHT80, M0.1 to M9.1	4	6	-69.1	-69.0	-66.8	-69.1	-56.4	-41.25	15.1
	VHT80, M0.2 to M9.2	4	6	-69.1	-69.0	-66.8	-69.1	-56.4	-41.25	15.1
	VHT80, M0.3 to M9.3	4	6	-69.1	-69.0	-66.8	-69.1	-56.4	-41.25	15.1
	VHT80 Beam Forming, M0.1 to M9.1	2	6	-69.1	-69.0			-60.0	-41.25	18.8
	VHT80 Beam Forming, M0.2 to M9.2	2	6	-69.1	-69.0			-60.0	-41.25	18.8
	VHT80 Beam Forming, M0.1 to M9.1	3	6	-69.1	-69.0	-66.8		-57.4	-41.25	16.1
	VHT80 Beam Forming, M0.2 to M9.2	3	6	-69.1	-69.0	-66.8		-57.4	-41.25	16.1
	VHT80 Beam Forming, M0.3 to M9.3	3	6	-69.1	-69.0	-66.8		-57.4	-41.25	16.1
	VHT80 Beam Forming, M0.1 to M9.1	4	6	-69.1	-69.0	-66.8	-69.1	-56.4	-41.25	15.1
	VHT80 Beam Forming, M0.2 to M9.2	4	6	-69.1	-69.0	-66.8	-69.1	-56.4	-41.25	15.1
VHT80 Beam Forming, M0.3 to M9.3	4	6	-69.1	-69.0	-66.8	-69.1	-56.4	-41.25	15.1	
VHT80 STBC, M0.1 to M9.1	2	6	-69.1	-69.0			-60.0	-41.25	18.8	



	VHT80 STBC, M0.1 to M9.1	3	6	-69.1	-69.0	-66.8		-57.4	-41.25	16.1
	VHT80 STBC, M0.1 to M9.1	4	6	-69.1	-69.0	-66.8	-69.1	-56.4	-41.25	15.1
5785	Non HT20, 6 to 54 Mbps	1	6	-68.7				-62.7	-41.25	21.5
	Non HT20, 6 to 54 Mbps	2	6	-68.7	-67.9			-59.3	-41.25	18.0
	Non HT20, 6 to 54 Mbps	3	6	-68.7	-67.9	-67.9		-57.4	-41.25	16.1
	Non HT20, 6 to 54 Mbps	4	6	-68.7	-67.9	-67.9	-68.9	-56.3	-41.25	15.1
	Non HT20 Beam Forming, 6 to 54 Mbps	2	9	-68.7	-67.9			-56.3	-41.25	15.0
	Non HT20 Beam Forming, 6 to 54 Mbps	3	11	-68.7	-67.9	-67.9		-52.6	-41.25	11.3
	Non HT20 Beam Forming, 6 to 54 Mbps	4	12	-68.7	-67.9	-67.9	-68.9	-50.3	-41.25	9.1
	HT/VHT20, M0 to M7	1	6	-68.6				-62.6	-41.25	21.4
	HT/VHT20, M0 to M7	2	6	-68.6	-67.8			-59.2	-41.25	17.9
	HT/VHT20, M8 to M15	2	6	-68.6	-67.8			-59.2	-41.25	17.9
	HT/VHT20, M0 to M7	3	6	-68.6	-67.8	-68.2		-57.4	-41.25	16.2
	HT/VHT20, M8 to M15	3	6	-68.6	-67.8	-68.2		-57.4	-41.25	16.2
	HT/VHT20, M16 to M23	3	6	-68.6	-67.8	-68.2		-57.4	-41.25	16.2
	HT/VHT20, M0 to M7	4	6	-68.6	-67.8	-68.2	-68.9	-56.3	-41.25	15.1
	HT/VHT20, M8 to M15	4	6	-68.6	-67.8	-68.2	-68.9	-56.3	-41.25	15.1
	HT/VHT20, M16 to M23	4	6	-68.6	-67.8	-68.2	-68.9	-56.3	-41.25	15.1
	HT/VHT20 Beam Forming, M0 to M7	2	9	-68.6	-67.8			-56.2	-41.25	14.9
	HT/VHT20 Beam Forming, M8 to M15	2	6	-68.6	-67.8			-59.2	-41.25	17.9
	HT/VHT20 Beam Forming, M0 to M7	3	11	-68.6	-67.8	-68.2		-52.6	-41.25	11.4
	HT/VHT20 Beam Forming, M8 to M15	3	8	-68.6	-67.8	-68.2		-55.6	-41.25	14.4
	HT/VHT20 Beam Forming, M16 to M23	3	6	-68.6	-67.8	-68.2		-57.4	-41.25	16.2
	HT/VHT20 Beam Forming, M0 to M7	4	12	-68.6	-67.8	-68.2	-68.9	-50.3	-41.25	9.1
	HT/VHT20 Beam Forming, M8 to M15	4	9	-68.6	-67.8	-68.2	-68.9	-53.3	-41.25	12.1
	HT/VHT20 Beam Forming, M16 to M23	4	7	-68.6	-67.8	-68.2	-68.9	-55.1	-41.25	13.9
HT/VHT20 STBC, M0 to M7	2	6	-68.6	-67.8			-59.2	-41.25	17.9	
HT/VHT20 STBC, M0 to M7	3	6	-68.6	-67.8	-68.2		-57.4	-41.25	16.2	
HT/VHT20 STBC, M0 to M7	4	6	-68.6	-67.8	-68.2	-68.9	-56.3	-41.25	15.1	
5795	Non HT40, 6 to 54 Mbps	1	6	-69.1				-63.1	-41.25	21.9
	Non HT40, 6 to 54 Mbps	2	6	-69.1	-69.3			-60.2	-41.25	18.9
	Non HT40, 6 to 54 Mbps	3	6	-69.1	-69.3	-67.1		-57.6	-41.25	16.4
	Non HT40, 6 to 54 Mbps	4	6	-69.1	-69.3	-67.1	-68.9	-56.5	-41.25	15.2
	HT/VHT40, M0 to M7	1	6	-69.0				-63.0	-41.25	21.8
	HT/VHT40, M0 to M7	2	6	-69.0	-69.1			-60.0	-41.25	18.8
	HT/VHT40, M8 to M15	2	6	-69.0	-69.1			-60.0	-41.25	18.8
	HT/VHT40, M0 to M7	3	6	-69.0	-69.1	-69.0		-58.3	-41.25	17.0
	HT/VHT40, M8 to M15	3	6	-69.0	-69.1	-69.0		-58.3	-41.25	17.0
	HT/VHT40, M16 to M23	3	6	-69.0	-69.1	-69.0		-58.3	-41.25	17.0



	HT/VHT40, M0 to M7	4	6	-69.0	-69.1	-69.0	-69.2	-57.1	-41.25	15.8
	HT/VHT40, M8 to M15	4	6	-69.0	-69.1	-69.0	-69.2	-57.1	-41.25	15.8
	HT/VHT40, M16 to M23	4	6	-69.0	-69.1	-69.0	-69.2	-57.1	-41.25	15.8
	HT/VHT40 Beam Forming, M0 to M7	2	9	-69.0	-69.1			-57.0	-41.25	15.8
	HT/VHT40 Beam Forming, M8 to M15	2	6	-69.0	-69.1			-60.0	-41.25	18.8
	HT/VHT40 Beam Forming, M0 to M7	3	11	-69.0	-69.1	-69.0		-53.5	-41.25	12.2
	HT/VHT40 Beam Forming, M8 to M15	3	8	-69.0	-69.1	-69.0		-56.5	-41.25	15.2
	HT/VHT40 Beam Forming, M16 to M23	3	6	-69.0	-69.1	-69.0		-58.3	-41.25	17.0
	HT/VHT40 Beam Forming, M0 to M7	4	12	-69.0	-69.1	-69.0	-69.2	-51.1	-41.25	9.8
	HT/VHT40 Beam Forming, M8 to M15	4	9	-69.0	-69.1	-69.0	-69.2	-54.1	-41.25	12.8
	HT/VHT40 Beam Forming, M16 to M23	4	7	-69.0	-69.1	-69.0	-69.2	-55.9	-41.25	14.6
	HT/VHT40 STBC, M0 to M7	2	6	-69.0	-69.1			-60.0	-41.25	18.8
	HT/VHT40 STBC, M0 to M7	3	6	-69.0	-69.1	-69.0		-58.3	-41.25	17.0
	HT/VHT40 STBC, M0 to M7	4	6	-69.0	-69.1	-69.0	-69.2	-57.1	-41.25	15.8
5825	Non HT20, 6 to 54 Mbps	1	6	-68.6				-62.6	-41.25	21.4
	Non HT20, 6 to 54 Mbps	2	6	-68.6	-66.5			-58.4	-41.25	17.2
	Non HT20, 6 to 54 Mbps	3	6	-68.6	-66.5	-66.8		-56.4	-41.25	15.2
	Non HT20, 6 to 54 Mbps	4	6	-68.6	-66.5	-66.8	-66.8	-55.1	-41.25	13.8
	Non HT20 Beam Forming, 6 to 54 Mbps	2	9	-68.6	-66.5			-55.4	-41.25	14.2
	Non HT20 Beam Forming, 6 to 54 Mbps	3	11	-68.6	-66.5	-66.8		-51.6	-41.25	10.4
	<b>Non HT20 Beam Forming, 6 to 54 Mbps</b>	<b>4</b>	<b>12</b>	<b>-68.6</b>	<b>-66.5</b>	<b>-66.8</b>	<b>-66.8</b>	<b>-49.1</b>	<b>-41.25</b>	<b>7.8</b>
	HT/VHT20, M0 to M7	1	6	-68.3				-62.3	-41.25	21.1
	HT/VHT20, M0 to M7	2	6	-68.3	-66.8			-58.5	-41.25	17.2
	HT/VHT20, M8 to M15	2	6	-68.3	-66.8			-58.5	-41.25	17.2
	HT/VHT20, M0 to M7	3	6	-68.3	-66.8	-66.5		-56.4	-41.25	15.1
	HT/VHT20, M8 to M15	3	6	-68.3	-66.8	-66.5		-56.4	-41.25	15.1
	HT/VHT20, M16 to M23	3	6	-68.3	-66.8	-66.5		-56.4	-41.25	15.1
	HT/VHT20, M0 to M7	4	6	-68.3	-66.8	-66.5	-68.4	-55.4	-41.25	14.1
	HT/VHT20, M8 to M15	4	6	-68.3	-66.8	-66.5	-68.4	-55.4	-41.25	14.1
	HT/VHT20, M16 to M23	4	6	-68.3	-66.8	-66.5	-68.4	-55.4	-41.25	14.1
	HT/VHT20 Beam Forming, M0 to M7	2	9	-68.3	-66.8			-55.5	-41.25	14.2
	HT/VHT20 Beam Forming, M8 to M15	2	6	-68.3	-66.8			-58.5	-41.25	17.2
	HT/VHT20 Beam Forming, M0 to M7	3	11	-68.3	-66.8	-66.5		-51.6	-41.25	10.3
	HT/VHT20 Beam Forming, M8 to M15	3	8	-68.3	-66.8	-66.5		-54.6	-41.25	13.3
	HT/VHT20 Beam Forming, M16 to M23	3	6	-68.3	-66.8	-66.5		-56.4	-41.25	15.1
	HT/VHT20 Beam Forming, M0 to M7	4	12	-68.3	-66.8	-66.5	-68.4	-49.4	-41.25	8.1
HT/VHT20 Beam Forming, M8 to M15	4	9	-68.3	-66.8	-66.5	-68.4	-52.4	-41.25	11.1	
HT/VHT20 Beam Forming, M16 to M23	4	7	-68.3	-66.8	-66.5	-68.4	-54.2	-41.25	12.9	
HT/VHT20 STBC, M0 to M7	2	6	-68.3	-66.8			-58.5	-41.25	17.2	
HT/VHT20 STBC, M0 to M7	3	6	-68.3	-66.8	-66.5		-56.4	-41.25	15.1	



HT/VHT20 STBC, M0 to M7	4	6	-68.3	-66.8	-66.5	-68.4	-55.4	-41.25	14.1
-------------------------	---	---	-------	-------	-------	-------	-------	--------	------





Frequency (MHz)	Mode	Tx Paths	Correlated Antenna Gain (dBi)	Tx 1 Spur Power (dBm)	Tx 2 Spur Power (dBm)	Tx 3 Spur Power (dBm)	Tx 4 Spur Power (dBm)	Total Conducted Spur (dBm)	Limit (dBm)	Margin (dB)
5745	Non HT20, 6 to 54 Mbps	1	6	-58.9				-52.9	-21.25	31.7
	Non HT20, 6 to 54 Mbps	2	6	-58.9	-59.3			-50.1	-21.25	28.8
	Non HT20, 6 to 54 Mbps	3	6	-58.9	-59.3	-58.4		-48.1	-21.25	26.8
	Non HT20, 6 to 54 Mbps	4	6	-58.9	-59.3	-58.4	-59.1	-46.9	-21.25	25.6
	Non HT20 Beam Forming, 6 to 54 Mbps	2	9	-58.9	-59.3			-47.1	-21.25	25.8
	Non HT20 Beam Forming, 6 to 54 Mbps	3	11	-58.9	-59.3	-58.4		-43.3	-21.25	22.0
	Non HT20 Beam Forming, 6 to 54 Mbps	4	12	-58.9	-59.3	-58.4	-59.1	-40.9	-21.25	19.6
	HT/VHT20, M0 to M7	1	6	-59.6				-53.6	-21.25	32.4
	HT/VHT20, M0 to M7	2	6	-59.6	-61.0			-51.2	-21.25	30.0
	HT/VHT20, M8 to M15	2	6	-59.6	-61.0			-51.2	-21.25	30.0
	HT/VHT20, M0 to M7	3	6	-59.6	-61.0	-60.7		-49.6	-21.25	28.4
	HT/VHT20, M8 to M15	3	6	-59.6	-61.0	-60.7		-49.6	-21.25	28.4
	HT/VHT20, M16 to M23	3	6	-59.6	-61.0	-60.7		-49.6	-21.25	28.4
	HT/VHT20, M0 to M7	4	6	-59.6	-61.0	-60.7	-58.8	-47.9	-21.25	26.7
	HT/VHT20, M8 to M15	4	6	-59.6	-61.0	-60.7	-58.8	-47.9	-21.25	26.7
	HT/VHT20, M16 to M23	4	6	-59.6	-61.0	-60.7	-58.8	-47.9	-21.25	26.7
	HT/VHT20 Beam Forming, M0 to M7	2	9	-59.6	-61.0			-48.2	-21.25	27.0
	HT/VHT20 Beam Forming, M8 to M15	2	6	-59.6	-61.0			-51.2	-21.25	30.0
	HT/VHT20 Beam Forming, M0 to M7	3	11	-59.6	-61.0	-60.7		-44.8	-21.25	23.6
	HT/VHT20 Beam Forming, M8 to M15	3	8	-59.6	-61.0	-60.7		-47.8	-21.25	26.6
	HT/VHT20 Beam Forming, M16 to M23	3	6	-59.6	-61.0	-60.7		-49.6	-21.25	28.4
	HT/VHT20 Beam Forming, M0 to M7	4	12	-59.6	-61.0	-60.7	-58.8	-41.9	-21.25	20.7
	HT/VHT20 Beam Forming, M8 to M15	4	9	-59.6	-61.0	-60.7	-58.8	-44.9	-21.25	23.7
	HT/VHT20 Beam Forming, M16 to M23	4	7	-59.6	-61.0	-60.7	-58.8	-46.7	-21.25	25.5
	HT/VHT20 STBC, M0 to M7	2	6	-59.6	-61.0			-51.2	-21.25	30.0
	HT/VHT20 STBC, M0 to M7	3	6	-59.6	-61.0	-60.7		-49.6	-21.25	28.4
	HT/VHT20 STBC, M0 to M7	4	6	-59.6	-61.0	-60.7	-58.8	-47.9	-21.25	26.7
	5755	Non HT40, 6 to 54 Mbps	1	6	-59.2				-53.2	-21.25
Non HT40, 6 to 54 Mbps		2	6	-59.2	-59.4			-50.3	-21.25	29.0
Non HT40, 6 to 54 Mbps		3	6	-59.2	-59.4	-59.7		-48.7	-21.25	27.4
Non HT40, 6 to 54 Mbps		4	6	-59.2	-59.4	-59.7	-58.4	-47.1	-21.25	25.9
HT/VHT40, M0 to M7		1	6	-58.7				-52.7	-21.25	31.5
HT/VHT40, M0 to M7		2	6	-58.7	-60.7			-50.6	-21.25	29.3



	HT/VHT40, M8 to M15	2	6	-58.7	-60.7			-50.6	-21.25	29.3
	HT/VHT40, M0 to M7	3	6	-58.7	-60.7	-59.9		-48.9	-21.25	27.7
	HT/VHT40, M8 to M15	3	6	-58.7	-60.7	-59.9		-48.9	-21.25	27.7
	HT/VHT40, M16 to M23	3	6	-58.7	-60.7	-59.9		-48.9	-21.25	27.7
	HT/VHT40, M0 to M7	4	6	-58.7	-60.7	-59.9	-59.8	-47.7	-21.25	26.4
	HT/VHT40, M8 to M15	4	6	-58.7	-60.7	-59.9	-59.8	-47.7	-21.25	26.4
	HT/VHT40, M16 to M23	4	6	-58.7	-60.7	-59.9	-59.8	-47.7	-21.25	26.4
	HT/VHT40 Beam Forming, M0 to M7	2	9	-58.7	-60.7			-47.6	-21.25	26.3
	HT/VHT40 Beam Forming, M8 to M15	2	6	-58.7	-60.7			-50.6	-21.25	29.3
	HT/VHT40 Beam Forming, M0 to M7	3	11	-58.7	-60.7	-59.9		-44.1	-21.25	22.9
	HT/VHT40 Beam Forming, M8 to M15	3	8	-58.7	-60.7	-59.9		-47.1	-21.25	25.9
	HT/VHT40 Beam Forming, M16 to M23	3	6	-58.7	-60.7	-59.9		-48.9	-21.25	27.7
	HT/VHT40 Beam Forming, M0 to M7	4	12	-58.7	-60.7	-59.9	-59.8	-41.7	-21.25	20.4
	HT/VHT40 Beam Forming, M8 to M15	4	9	-58.7	-60.7	-59.9	-59.8	-44.7	-21.25	23.4
	HT/VHT40 Beam Forming, M16 to M23	4	7	-58.7	-60.7	-59.9	-59.8	-46.5	-21.25	25.2
	HT/VHT40 STBC, M0 to M7	2	6	-58.7	-60.7			-50.6	-21.25	29.3
	HT/VHT40 STBC, M0 to M7	3	6	-58.7	-60.7	-59.9		-48.9	-21.25	27.7
	HT/VHT40 STBC, M0 to M7	4	6	-58.7	-60.7	-59.9	-59.8	-47.7	-21.25	26.4
5775	Non HT80, 6 to 54 Mbps	1	6	-59.9				-53.9	-21.25	32.7
	Non HT80, 6 to 54 Mbps	2	6	-59.9	-60.7			-51.3	-21.25	30.0
	Non HT80, 6 to 54 Mbps	3	6	-59.9	-60.7	-58.7		-48.9	-21.25	27.7
	Non HT80, 6 to 54 Mbps	4	6	-59.9	-60.7	-58.7	-59.8	-47.7	-21.25	26.4
	VHT80, M0.1 to M9.1	1	6	-57.7				-51.7	-21.25	30.5
	VHT80, M0.1 to M9.1	2	6	-57.7	-61.0			-50.0	-21.25	28.8
	VHT80, M0.2 to M9.2	2	6	-57.7	-61.0			-50.0	-21.25	28.8
	VHT80, M0.1 to M9.1	3	6	-57.7	-61.0	-58.0		-47.9	-21.25	26.6
	VHT80, M0.2 to M9.2	3	6	-57.7	-61.0	-58.0		-47.9	-21.25	26.6
	VHT80, M0.3 to M9.3	3	6	-57.7	-61.0	-58.0		-47.9	-21.25	26.6
	VHT80, M0.1 to M9.1	4	6	-57.7	-61.0	-58.0	-58.9	-46.7	-21.25	25.5
	VHT80, M0.2 to M9.2	4	6	-57.7	-61.0	-58.0	-58.9	-46.7	-21.25	25.5
	VHT80, M0.3 to M9.3	4	6	-57.7	-61.0	-58.0	-58.9	-46.7	-21.25	25.5
	VHT80 Beam Forming, M0.1 to M9.1	2	6	-57.7	-61.0			-50.0	-21.25	28.8
	VHT80 Beam Forming, M0.2 to M9.2	2	6	-57.7	-61.0			-50.0	-21.25	28.8
	VHT80 Beam Forming, M0.1 to M9.1	3	6	-57.7	-61.0	-58.0		-47.9	-21.25	26.6
	VHT80 Beam Forming, M0.2 to M9.2	3	6	-57.7	-61.0	-58.0		-47.9	-21.25	26.6
	VHT80 Beam Forming, M0.3 to M9.3	3	6	-57.7	-61.0	-58.0		-47.9	-21.25	26.6
	VHT80 Beam Forming, M0.1 to M9.1	4	6	-57.7	-61.0	-58.0	-58.9	-46.7	-21.25	25.5
	VHT80 Beam Forming, M0.2 to M9.2	4	6	-57.7	-61.0	-58.0	-58.9	-46.7	-21.25	25.5
VHT80 Beam Forming, M0.3 to M9.3	4	6	-57.7	-61.0	-58.0	-58.9	-46.7	-21.25	25.5	
VHT80 STBC, M0.1 to M9.1	2	6	-57.7	-61.0			-50.0	-21.25	28.8	



	VHT80 STBC, M0.1 to M9.1	3	6	-57.7	-61.0	-58.0		-47.9	-21.25	26.6
	VHT80 STBC, M0.1 to M9.1	4	6	-57.7	-61.0	-58.0	-58.9	-46.7	-21.25	25.5
5785	Non HT20, 6 to 54 Mbps	1	6	-58.4				-52.4	-21.25	31.2
	Non HT20, 6 to 54 Mbps	2	6	-58.4	-60.3			-50.2	-21.25	29.0
	Non HT20, 6 to 54 Mbps	3	6	-58.4	-60.3	-59.4		-48.5	-21.25	27.3
	Non HT20, 6 to 54 Mbps	4	6	-58.4	-60.3	-59.4	-59.6	-47.4	-21.25	26.1
	Non HT20 Beam Forming, 6 to 54 Mbps	2	9	-58.4	-60.3			-47.2	-21.25	26.0
	Non HT20 Beam Forming, 6 to 54 Mbps	3	11	-58.4	-60.3	-59.4		-43.7	-21.25	22.5
	Non HT20 Beam Forming, 6 to 54 Mbps	4	12	-58.4	-60.3	-59.4	-59.6	-41.4	-21.25	20.1
	HT/VHT20, M0 to M7	1	6	-56.9				-50.9	-21.25	29.7
	HT/VHT20, M0 to M7	2	6	-56.9	-59.2			-48.9	-21.25	27.6
	HT/VHT20, M8 to M15	2	6	-56.9	-59.2			-48.9	-21.25	27.6
	HT/VHT20, M0 to M7	3	6	-56.9	-59.2	-59.0		-47.5	-21.25	26.2
	HT/VHT20, M8 to M15	3	6	-56.9	-59.2	-59.0		-47.5	-21.25	26.2
	HT/VHT20, M16 to M23	3	6	-56.9	-59.2	-59.0		-47.5	-21.25	26.2
	HT/VHT20, M0 to M7	4	6	-56.9	-59.2	-59.0	-59.5	-46.5	-21.25	25.2
	HT/VHT20, M8 to M15	4	6	-56.9	-59.2	-59.0	-59.5	-46.5	-21.25	25.2
	HT/VHT20, M16 to M23	4	6	-56.9	-59.2	-59.0	-59.5	-46.5	-21.25	25.2
	HT/VHT20 Beam Forming, M0 to M7	2	9	-56.9	-59.2			-45.9	-21.25	24.6
	HT/VHT20 Beam Forming, M8 to M15	2	6	-56.9	-59.2			-48.9	-21.25	27.6
	HT/VHT20 Beam Forming, M0 to M7	3	11	-56.9	-59.2	-59.0		-42.7	-21.25	21.4
	HT/VHT20 Beam Forming, M8 to M15	3	8	-56.9	-59.2	-59.0		-45.7	-21.25	24.4
	HT/VHT20 Beam Forming, M16 to M23	3	6	-56.9	-59.2	-59.0		-47.5	-21.25	26.2
	HT/VHT20 Beam Forming, M0 to M7	4	12	-56.9	-59.2	-59.0	-59.5	-40.5	-21.25	19.2
	HT/VHT20 Beam Forming, M8 to M15	4	9	-56.9	-59.2	-59.0	-59.5	-43.5	-21.25	22.2
	HT/VHT20 Beam Forming, M16 to M23	4	7	-56.9	-59.2	-59.0	-59.5	-45.3	-21.25	24.0
HT/VHT20 STBC, M0 to M7	2	6	-56.9	-59.2			-48.9	-21.25	27.6	
HT/VHT20 STBC, M0 to M7	3	6	-56.9	-59.2	-59.0		-47.5	-21.25	26.2	
HT/VHT20 STBC, M0 to M7	4	6	-56.9	-59.2	-59.0	-59.5	-46.5	-21.25	25.2	
5795	Non HT40, 6 to 54 Mbps	1	6	-60.0				-54.0	-21.25	32.8
	Non HT40, 6 to 54 Mbps	2	6	-60.0	-61.3			-51.6	-21.25	30.3
	Non HT40, 6 to 54 Mbps	3	6	-60.0	-61.3	-57.8		-48.7	-21.25	27.4
	Non HT40, 6 to 54 Mbps	4	6	-60.0	-61.3	-57.8	-58.0	-47.0	-21.25	25.8
	HT/VHT40, M0 to M7	1	6	-59.8				-53.8	-21.25	32.6
	HT/VHT40, M0 to M7	2	6	-59.8	-59.7			-50.7	-21.25	29.5
	HT/VHT40, M8 to M15	2	6	-59.8	-59.7			-50.7	-21.25	29.5
	HT/VHT40, M0 to M7	3	6	-59.8	-59.7	-56.0		-47.3	-21.25	26.1
	HT/VHT40, M8 to M15	3	6	-59.8	-59.7	-56.0		-47.3	-21.25	26.1
	HT/VHT40, M16 to M23	3	6	-59.8	-59.7	-56.0		-47.3	-21.25	26.1



	HT/VHT40, M0 to M7	4	6	-59.8	-59.7	-56.0	-58.5	-46.2	-21.25	24.9
	HT/VHT40, M8 to M15	4	6	-59.8	-59.7	-56.0	-58.5	-46.2	-21.25	24.9
	HT/VHT40, M16 to M23	4	6	-59.8	-59.7	-56.0	-58.5	-46.2	-21.25	24.9
	HT/VHT40 Beam Forming, M0 to M7	2	9	-59.8	-59.7			-47.7	-21.25	26.5
	HT/VHT40 Beam Forming, M8 to M15	2	6	-59.8	-59.7			-50.7	-21.25	29.5
	HT/VHT40 Beam Forming, M0 to M7	3	11	-59.8	-59.7	-56.0		-42.5	-21.25	21.3
	HT/VHT40 Beam Forming, M8 to M15	3	8	-59.8	-59.7	-56.0		-45.5	-21.25	24.3
	HT/VHT40 Beam Forming, M16 to M23	3	6	-59.8	-59.7	-56.0		-47.3	-21.25	26.1
	<b>HT/VHT40 Beam Forming, M0 to M7</b>	<b>4</b>	<b>12</b>	<b>-59.8</b>	<b>-59.7</b>	<b>-56.0</b>	<b>-58.5</b>	<b>-40.2</b>	<b>-21.25</b>	<b>18.9</b>
	HT/VHT40 Beam Forming, M8 to M15	4	9	-59.8	-59.7	-56.0	-58.5	-43.2	-21.25	21.9
	HT/VHT40 Beam Forming, M16 to M23	4	7	-59.8	-59.7	-56.0	-58.5	-45.0	-21.25	23.7
	HT/VHT40 STBC, M0 to M7	2	6	-59.8	-59.7			-50.7	-21.25	29.5
	HT/VHT40 STBC, M0 to M7	3	6	-59.8	-59.7	-56.0		-47.3	-21.25	26.1
	HT/VHT40 STBC, M0 to M7	4	6	-59.8	-59.7	-56.0	-58.5	-46.2	-21.25	24.9
5825	Non HT20, 6 to 54 Mbps	1	6	-60.8				-54.8	-21.25	33.6
	Non HT20, 6 to 54 Mbps	2	6	-60.8	-57.5			-49.8	-21.25	28.6
	Non HT20, 6 to 54 Mbps	3	6	-60.8	-57.5	-58.7		-48.0	-21.25	26.8
	Non HT20, 6 to 54 Mbps	4	6	-60.8	-57.5	-58.7	-58.8	-46.8	-21.25	25.5
	Non HT20 Beam Forming, 6 to 54 Mbps	2	9	-60.8	-57.5			-46.8	-21.25	25.6
	Non HT20 Beam Forming, 6 to 54 Mbps	3	11	-60.8	-57.5	-58.7		-43.2	-21.25	22.0
	Non HT20 Beam Forming, 6 to 54 Mbps	4	12	-60.8	-57.5	-58.7	-58.8	-40.8	-21.25	19.5
	HT/VHT20, M0 to M7	1	6	-58.6				-52.6	-21.25	31.4
	HT/VHT20, M0 to M7	2	6	-58.6	-59.0			-49.8	-21.25	28.5
	HT/VHT20, M8 to M15	2	6	-58.6	-59.0			-49.8	-21.25	28.5
	HT/VHT20, M0 to M7	3	6	-58.6	-59.0	-58.4		-47.9	-21.25	26.6
	HT/VHT20, M8 to M15	3	6	-58.6	-59.0	-58.4		-47.9	-21.25	26.6
	HT/VHT20, M16 to M23	3	6	-58.6	-59.0	-58.4		-47.9	-21.25	26.6
	HT/VHT20, M0 to M7	4	6	-58.6	-59.0	-58.4	-62.9	-47.4	-21.25	26.1
	HT/VHT20, M8 to M15	4	6	-58.6	-59.0	-58.4	-62.9	-47.4	-21.25	26.1
	HT/VHT20, M16 to M23	4	6	-58.6	-59.0	-58.4	-62.9	-47.4	-21.25	26.1
	HT/VHT20 Beam Forming, M0 to M7	2	9	-58.6	-59.0			-46.8	-21.25	25.5
	HT/VHT20 Beam Forming, M8 to M15	2	6	-58.6	-59.0			-49.8	-21.25	28.5
	HT/VHT20 Beam Forming, M0 to M7	3	11	-58.6	-59.0	-58.4		-43.1	-21.25	21.8
	HT/VHT20 Beam Forming, M8 to M15	3	8	-58.6	-59.0	-58.4		-46.1	-21.25	24.8
	HT/VHT20 Beam Forming, M16 to M23	3	6	-58.6	-59.0	-58.4		-47.9	-21.25	26.6
	HT/VHT20 Beam Forming, M0 to M7	4	12	-58.6	-59.0	-58.4	-62.9	-41.4	-21.25	20.1
	HT/VHT20 Beam Forming, M8 to M15	4	9	-58.6	-59.0	-58.4	-62.9	-44.4	-21.25	23.1
	HT/VHT20 Beam Forming, M16 to M23	4	7	-58.6	-59.0	-58.4	-62.9	-46.2	-21.25	24.9
HT/VHT20 STBC, M0 to M7	2	6	-58.6	-59.0			-49.8	-21.25	28.5	
HT/VHT20 STBC, M0 to M7	3	6	-58.6	-59.0	-58.4		-47.9	-21.25	26.6	



HT/VHT20 STBC, M0 to M7	4	6	-58.6	-59.0	-58.4	-62.9	-47.4	-21.25	26.1
-------------------------	---	---	-------	-------	-------	-------	-------	--------	------



### Conducted Spurs Average, All Antennas



### Conducted Spurs Peak, All Antennas





**Conducted Spurs Average, 5825 MHz, Non HT20 Beam Forming, 6 to 54 Mbps**



**Antenna A**



**Antenna B**



**Antenna C**



**Antenna D**



**Conducted Spurs Peak, 5795 MHz, HT/VHT40 Beam Forming, M0 to M7**

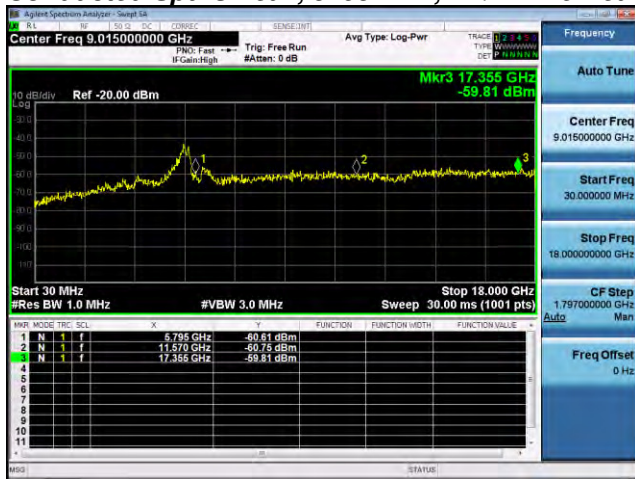

**Antenna A**

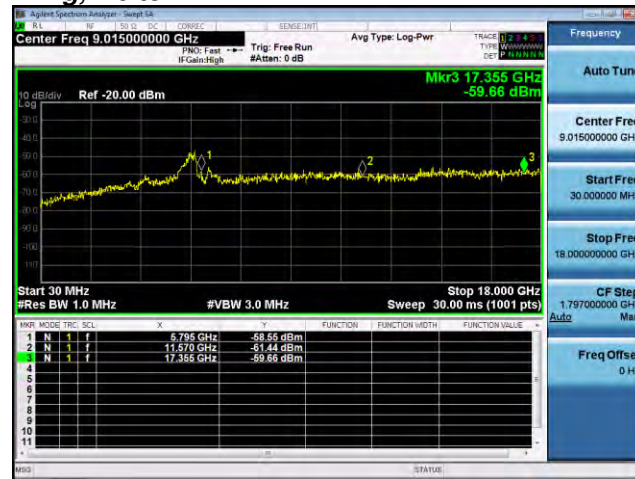

**Antenna B**

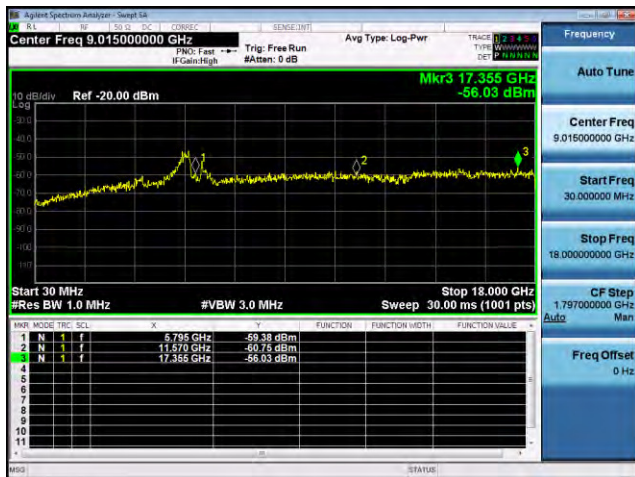

**Antenna C**

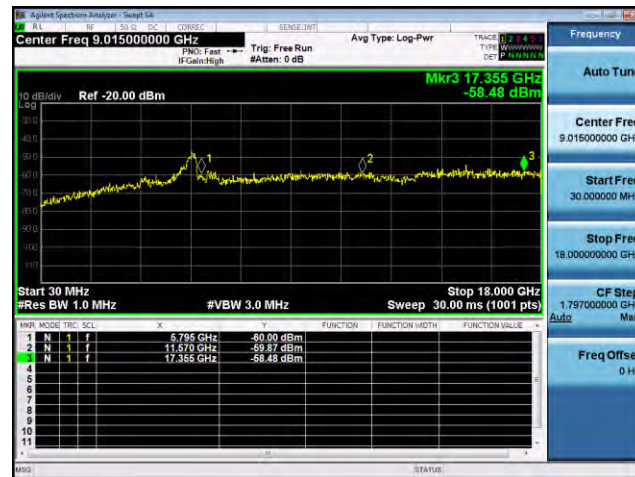

**Antenna D**





## A.6 Conducted Bandedge

**15.407** (b) *Undesirable emission limits.* Except as shown in paragraph (b) (7) of this section, the maximum emissions outside of the frequency bands of operation shall be attenuated in accordance with the following limits:

(4) For transmitters operating in the 5.725-5.85 GHz band: All emissions within the frequency range from the band edge to 10 MHz above or below the band edge shall not exceed an e.i.r.p. of -17 dBm/MHz; for frequencies 10 MHz or greater above or below the band edge, emissions shall not exceed an e.i.r.p. of -27 dBm/MHz.

(6) Unwanted emissions below 1 GHz must comply with the general field strength limits set forth in 15.209.

(7) The provisions of §15.205 apply to intentional radiators operating under this section.

(8) When measuring the emission limits, the nominal carrier frequency shall be adjusted as close to the upper and lower frequency band edges as the design of the equipment permits

### Test Procedure

Ref. KDB 789033 D02 General UNII Test Procedures New Rules v01r01  
ANSI C63.10: 2013

<b>Conducted Bandedge</b>
Test Procedure
1. Connect the antenna port(s) to the spectrum analyzer input. 2. Place the radio in continuous transmit mode. Use the procedures in ANSI C63.10: 2013 to substitute conducted measurements in place of radiated measurements. 3. Configure Spectrum analyzer as per test parameters below (be sure to enter all losses between the transmitter output and the spectrum analyzer). 4. Place a marker at the end of the restricted band closest to the transmit frequency to show compliance. Also measure any emissions in the restricted bands. 5. The "measure-and-sum technique" is used for measuring in-band transmit power of a device. In the measure-and-sum approach, the conducted emission level is measured at each antenna port. The measured results at the various antenna ports are then summed mathematically to determine the total emission level from the device. Summing is performed in linear power units. The worst case output is recorded. 6. Place a marker at the end of the restricted band closest to the transmit frequency to show compliance. Also measure any emissions in the restricted bands. 7. Capture graphs and record pertinent measurement data.

Ref. ANSI C63.10: 2013 section 12.7.6 (peak) & 12.7.7.3 (average, Method VB-A (Alternative))

<b>Conducted Bandedge</b>
Test parameters restricted Band
RBW = 1 MHz VBW ≥ 3 x RBW for Peak, 100Hz for Average Sweep = Auto couple Detector = Peak Trace = Max Hold.

System Number	Description	Samples	System under test	Support equipment
1	EUT	S01	<input checked="" type="checkbox"/>	<input type="checkbox"/>
	Support	S02	<input type="checkbox"/>	<input checked="" type="checkbox"/>

<b>Tested By :</b> Jose Aguirre	<b>Date of testing:</b> 01-Jan-16 - 03-Mar-16
<b>Test Result : PASS</b>	

See Appendix C for list of test equipment



Frequency (MHz)	Mode	Tx Paths	Correlated Antenna Gain (dBi)	Tx 1 Bandedge Level (dBm)	Tx 2 Bandedge Level (dBm)	Tx 3 Bandedge Level (dBm)	Tx 4 Bandedge Level (dBm)	Total Tx Bandedge Level (dBm)	Limit (dBm)	Margin (dB)
5745	Non HT20, 6 to 54 Mbps	1	6	-33.6				-27.6	-27.00	0.6
	Non HT20, 6 to 54 Mbps	2	6	-35.9	-38.2			-27.9	-27.00	0.9
	Non HT20, 6 to 54 Mbps	3	6	-37.9	-39.6	-39.8		-28.2	-27.00	1.2
	Non HT20, 6 to 54 Mbps	4	6	-38.8	-40.6	-40.1	-38.7	-27.5	-27.00	0.5
	Non HT20 Beam Forming, 6 to 54 Mbps	2	9	-38.8	-40.6			-27.6	-27.00	0.6
	Non HT20 Beam Forming, 6 to 54 Mbps	3	11	-41.9	-44.7	-43.6		-27.7	-27.00	0.7
	Non HT20 Beam Forming, 6 to 54 Mbps	4	12	-44.7	-45.6	-45.9	-45.3	-27.3	-27.00	0.3
	HT/VHT20, M0 to M7	1	6	-33.6				-27.6	-27.00	0.6
	HT/VHT20, M0 to M7	2	6	-35.2	-37.3			-27.1	-27.00	0.1
	HT/VHT20, M8 to M15	2	6	-35.2	-37.3			-27.1	-27.00	0.1
	HT/VHT20, M0 to M7	3	6	-37.2	-38.8	-38.4		-27.3	-27.00	0.3
	HT/VHT20, M8 to M15	3	6	-37.2	-38.8	-38.4		-27.3	-27.00	0.3
	HT/VHT20, M16 to M23	3	6	-37.2	-38.8	-38.4		-27.3	-27.00	0.3
	HT/VHT20, M0 to M7	4	6	-38.7	-40.1	-40.1	-39.0	-27.4	-27.00	0.4
	HT/VHT20, M8 to M15	4	6	-38.7	-40.1	-40.1	-39.0	-27.4	-27.00	0.4
	HT/VHT20, M16 to M23	4	6	-38.7	-40.1	-40.1	-39.0	-27.4	-27.00	0.4
	HT/VHT20 Beam Forming, M0 to M7	2	9	-38.7	-40.1			-27.3	-27.00	0.3
	HT/VHT20 Beam Forming, M8 to M15	2	6	-35.2	-37.3			-27.1	-27.00	0.1
	HT/VHT20 Beam Forming, M0 to M7	3	11	-41.7	-44.4	-43.7		-27.5	-27.00	0.5
	<b>HT/VHT20 Beam Forming, M8 to M15</b>	<b>3</b>	<b>8</b>	<b>-38.7</b>	<b>-40.1</b>	<b>-40.1</b>		<b>-27.0</b>	<b>-27.00</b>	<b>0.0</b>
	HT/VHT20 Beam Forming, M16 to M23	3	6	-37.2	-38.8	-38.4		-27.3	-27.00	0.3
	HT/VHT20 Beam Forming, M0 to M7	4	12	-44.3	-45.6	-46.0	-44.8	-27.1	-27.00	0.1
	HT/VHT20 Beam Forming, M8 to M15	4	9	-41.7	-44.4	-43.7	-41.3	-27.6	-27.00	0.6
	HT/VHT20 Beam Forming, M16 to M23	4	7	-39.7	-42.3	-41.1	-40.3	-27.5	-27.00	0.5
	HT/VHT20 STBC, M0 to M7	2	6	-35.2	-37.3			-27.1	-27.00	0.1
	HT/VHT20 STBC, M0 to M7	3	6	-37.2	-38.8	-38.4		-27.3	-27.00	0.3
	HT/VHT20 STBC, M0 to M7	4	6	-38.7	-40.1	-40.1	-39.0	-27.4	-27.00	0.4
	5755	Non HT40, 6 to 54 Mbps	1	6	-34.2				-28.2	-27.00
Non HT40, 6 to 54 Mbps		2	6	-36.9	-35.4			-27.1	-27.00	0.1
Non HT40, 6 to 54 Mbps		3	6	-39.2	-41.0	-38.6		-28.7	-27.00	1.7
Non HT40, 6 to 54 Mbps		4	6	-39.2	-41.0	-38.6	-39.0	-27.3	-27.00	0.3
HT/VHT40, M0 to M7		1	6	-33.0				-27.0	-27.00	0.0



HT/VHT40, M0 to M7	2	6	-35.1	-37.3			-27.1	-27.00	0.1
HT/VHT40, M8 to M15	2	6	-35.1	-37.3			-27.1	-27.00	0.1
HT/VHT40, M0 to M7	3	6	-41.4	-39.1	-36.7		-27.9	-27.00	0.9
HT/VHT40, M8 to M15	3	6	-41.4	-39.1	-36.7		-27.9	-27.00	0.9
HT/VHT40, M16 to M23	3	6	-41.4	-39.1	-36.7		-27.9	-27.00	0.9
HT/VHT40, M0 to M7	4	6	-38.2	-41.6	-38.8	-40.6	-27.6	-27.00	0.6
HT/VHT40, M8 to M15	4	6	-38.2	-41.6	-38.8	-40.6	-27.6	-27.00	0.6
HT/VHT40, M16 to M23	4	6	-38.2	-41.6	-38.8	-40.6	-27.6	-27.00	0.6
HT/VHT40 Beam Forming, M0 to M7	2	9	-41.4	-39.1			-28.1	-27.00	1.1
HT/VHT40 Beam Forming, M8 to M15	2	6	-35.1	-37.3			-27.1	-27.00	0.1
HT/VHT40 Beam Forming, M0 to M7	3	11	-44.3	-46.2	-48.4		-30.4	-27.00	3.4
HT/VHT40 Beam Forming, M8 to M15	3	8	-40.3	-42.8	-41.6		-28.9	-27.00	1.9
HT/VHT40 Beam Forming, M16 to M23	3	6	-41.4	-39.1	-36.7		-27.9	-27.00	0.9
HT/VHT40 Beam Forming, M0 to M7	4	12	-44.1	-46.9	-48.4	-43.2	-27.1	-27.00	0.1
HT/VHT40 Beam Forming, M8 to M15	4	9	-39.4	-46.5	-41.9	-43.7	-27.1	-27.00	0.1
HT/VHT40 Beam Forming, M16 to M23	4	7	-40.3	-42.8	-41.6	-40.8	-28.1	-27.00	1.1
HT/VHT40 STBC, M0 to M7	2	6	-35.1	-37.3			-27.1	-27.00	0.1
HT/VHT40 STBC, M0 to M7	3	6	-41.4	-39.1	-36.7		-27.9	-27.00	0.9
HT/VHT40 STBC, M0 to M7	4	6	-38.2	-41.6	-38.8	-40.6	-27.6	-27.00	0.6

Non HT80, 6 to 54 Mbps	1	6	-39.2				-33.2	-27.00	6.2
Non HT80, 6 to 54 Mbps	2	6	-39.2	-34.5			-27.2	-27.00	0.2
Non HT80, 6 to 54 Mbps	3	6	-41.9	-37.5	-36.7		-27.4	-27.00	0.4
Non HT80, 6 to 54 Mbps	4	6	-42.6	-36.7	-43.2	-41.6	-28.1	-27.00	1.1
VHT80, M0.1 to M9.1	1	6	-35.5				-29.5	-27.00	2.5
VHT80, M0.1 to M9.1	2	6	-37.3	-38.2			-28.7	-27.00	1.7
VHT80, M0.2 to M9.2	2	6	-37.3	-38.2			-28.7	-27.00	1.7
VHT80, M0.1 to M9.1	3	6	-37.3	-38.2	-38.0		-27.0	-27.00	0.0
VHT80, M0.2 to M9.2	3	6	-37.3	-38.2	-38.0		-27.0	-27.00	0.0
VHT80, M0.3 to M9.3	3	6	-37.3	-38.2	-38.0		-27.0	-27.00	0.0
VHT80, M0.1 to M9.1	4	6	-40.4	-40.7	-40.9	-37.0	-27.4	-27.00	0.4
VHT80, M0.2 to M9.2	4	6	-40.4	-40.7	-40.9	-37.0	-27.4	-27.00	0.4
VHT80, M0.3 to M9.3	4	6	-40.4	-40.7	-40.9	-37.0	-27.4	-27.00	0.4
VHT80 Beam Forming, M0.1 to M9.1	2	6	-37.3	-38.2			-28.7	-27.00	1.7
VHT80 Beam Forming, M0.2 to M9.2	2	6	-37.3	-38.2			-28.7	-27.00	1.7
VHT80 Beam Forming, M0.1 to M9.1	3	6	-37.3	-38.2	-38.0		-27.0	-27.00	0.0
VHT80 Beam Forming, M0.2 to M9.2	3	6	-37.3	-38.2	-38.0		-27.0	-27.00	0.0
VHT80 Beam Forming, M0.3 to M9.3	3	6	-37.3	-38.2	-38.0		-27.0	-27.00	0.0
VHT80 Beam Forming, M0.1 to M9.1	4	6	-40.4	-40.7	-40.9	-37.0	-27.4	-27.00	0.4
VHT80 Beam Forming, M0.2 to M9.2	4	6	-40.4	-40.7	-40.9	-37.0	-27.4	-27.00	0.4
VHT80 Beam Forming, M0.3 to M9.3	4	6	-40.4	-40.7	-40.9	-37.0	-27.4	-27.00	0.4

5775



	VHT80 STBC, M0.1 to M9.1	2	6	-37.3	-38.2			-28.7	-27.00	1.7
	VHT80 STBC, M0.1 to M9.1	3	6	-37.3	-38.2	-38.0		-27.0	-27.00	0.0
	VHT80 STBC, M0.1 to M9.1	4	6	-40.4	-40.7	-40.9	-37.0	-27.4	-27.00	0.4
5795	Non HT40, 6 to 54 Mbps	1	6	-36.4				-30.4	-27.00	3.4
	Non HT40, 6 to 54 Mbps	2	6	-40.5	-46.1			-33.4	-27.00	6.4
	Non HT40, 6 to 54 Mbps	3	6	-40.5	-46.1	-44.2		-32.2	-27.00	5.2
	Non HT40, 6 to 54 Mbps	4	6	-40.5	-46.1	-44.2	-39.7	-29.9	-27.00	2.9
	HT/VHT40, M0 to M7	1	6	-52.2				-46.2	-27.00	19.2
	HT/VHT40, M0 to M7	2	6	-52.2	-51.7			-42.9	-27.00	15.9
	HT/VHT40, M8 to M15	2	6	-52.2	-51.7			-42.9	-27.00	15.9
	HT/VHT40, M0 to M7	3	6	-52.2	-51.7	-46.4		-38.5	-27.00	11.5
	HT/VHT40, M8 to M15	3	6	-52.2	-51.7	-46.4		-38.5	-27.00	11.5
	HT/VHT40, M16 to M23	3	6	-52.2	-51.7	-46.4		-38.5	-27.00	11.5
	HT/VHT40, M0 to M7	4	6	-52.2	-51.7	-46.4	-44.4	-35.4	-27.00	8.4
	HT/VHT40, M8 to M15	4	6	-52.2	-51.7	-46.4	-44.4	-35.4	-27.00	8.4
	HT/VHT40, M16 to M23	4	6	-52.2	-51.7	-46.4	-44.4	-35.4	-27.00	8.4
	HT/VHT40 Beam Forming, M0 to M7	2	9	-52.2	-51.7			-39.9	-27.00	12.9
	HT/VHT40 Beam Forming, M8 to M15	2	6	-52.2	-51.7			-42.9	-27.00	15.9
	HT/VHT40 Beam Forming, M0 to M7	3	11	-52.2	-51.7	-46.4		-33.7	-27.00	6.7
	HT/VHT40 Beam Forming, M8 to M15	3	8	-52.2	-51.7	-46.4		-36.7	-27.00	9.7
	HT/VHT40 Beam Forming, M16 to M23	3	6	-52.2	-51.7	-46.4		-38.5	-27.00	11.5
	HT/VHT40 Beam Forming, M0 to M7	4	12	-52.2	-51.7	-46.4	-44.4	-29.4	-27.00	2.4
	HT/VHT40 Beam Forming, M8 to M15	4	9	-52.2	-51.7	-46.4	-44.4	-32.4	-27.00	5.4
	HT/VHT40 Beam Forming, M16 to M23	4	7	-52.2	-51.7	-46.4	-44.4	-34.2	-27.00	7.2
HT/VHT40 STBC, M0 to M7	2	6	-52.2	-51.7			-42.9	-27.00	15.9	
HT/VHT40 STBC, M0 to M7	3	6	-52.2	-51.7	-46.4		-38.5	-27.00	11.5	
HT/VHT40 STBC, M0 to M7	4	6	-52.2	-51.7	-46.4	-44.4	-35.4	-27.00	8.4	
5825	Non HT20, 6 to 54 Mbps	1	6	-34.5				-28.5	-27.00	1.5
	Non HT20, 6 to 54 Mbps	2	6	-36.7	-36.5			-27.6	-27.00	0.6
	Non HT20, 6 to 54 Mbps	3	6	-38.7	-37.8	-38.9		-27.7	-27.00	0.7
	Non HT20, 6 to 54 Mbps	4	6	-39.2	-39.0	-39.9	-40.5	-27.6	-27.00	0.6
	<b>Non HT20 Beam Forming, 6 to 54 Mbps</b>	<b>2</b>	<b>9</b>	<b>-39.2</b>	<b>-39.0</b>			<b>-27.1</b>	<b>-27.00</b>	<b>0.1</b>
	Non HT20 Beam Forming, 6 to 54 Mbps	3	11	-43.0	-43.2	-43.8		-27.7	-27.00	0.7
	Non HT20 Beam Forming, 6 to 54 Mbps	4	12	-45.6	-45.8	-46.3	-46.3	-28.0	-27.00	1.0
	HT/VHT20, M0 to M7	1	6	-33.2				-27.2	-27.00	0.2
	HT/VHT20, M0 to M7	2	6	-36.8	-36.5			-27.6	-27.00	0.6
	HT/VHT20, M8 to M15	2	6	-36.8	-36.5			-27.6	-27.00	0.6
	HT/VHT20, M0 to M7	3	6	-39.0	-38.3	-38.9		-28.0	-27.00	1.0
	HT/VHT20, M8 to M15	3	6	-39.0	-38.3	-38.9		-28.0	-27.00	1.0



HT/VHT20, M16 to M23	3	6	-39.0	-38.3	-38.9		-28.0	-27.00	1.0
HT/VHT20, M0 to M7	4	6	-38.7	-39.1	-40.0	-40.5	-27.5	-27.00	0.5
HT/VHT20, M8 to M15	4	6	-38.7	-39.1	-40.0	-40.5	-27.5	-27.00	0.5
HT/VHT20, M16 to M23	4	6	-38.7	-39.1	-40.0	-40.5	-27.5	-27.00	0.5
HT/VHT20 Beam Forming, M0 to M7	2	9	-40.3	-40.1			-28.2	-27.00	1.2
HT/VHT20 Beam Forming, M8 to M15	2	6	-36.8	-36.5			-27.6	-27.00	0.6
HT/VHT20 Beam Forming, M0 to M7	3	11	-42.0	-42.9	-43.2		-27.1	-27.00	0.1
HT/VHT20 Beam Forming, M8 to M15	3	8	-40.3	-40.1	-41.0		-27.9	-27.00	0.9
HT/VHT20 Beam Forming, M16 to M23	3	6	-39.0	-38.3	-38.9		-28.0	-27.00	1.0
HT/VHT20 Beam Forming, M0 to M7	4	12	-45.0	-44.6	-44.8	-46.5	-27.1	-27.00	0.1
HT/VHT20 Beam Forming, M8 to M15	4	9	-42.0	-42.9	-43.2	-43.7	-27.9	-27.00	0.9
HT/VHT20 Beam Forming, M16 to M23	4	7	-40.3	-40.1	-41.0	-41.4	-27.4	-27.00	0.4
HT/VHT20 STBC, M0 to M7	2	6	-36.8	-36.5			-27.6	-27.00	0.6
HT/VHT20 STBC, M0 to M7	3	6	-39.0	-38.3	-38.9		-28.0	-27.00	1.0
HT/VHT20 STBC, M0 to M7	4	6	-38.7	-39.1	-40.0	-40.5	-27.5	-27.00	0.5



**Conducted Bandedge Peak, 5755 MHz, HT/VHT40, M0 to M7**



**Antenna A**



**Conducted Bandedge Peak, 5825 MHz, Non HT20 Beam Forming, 6 to 54 Mbps**

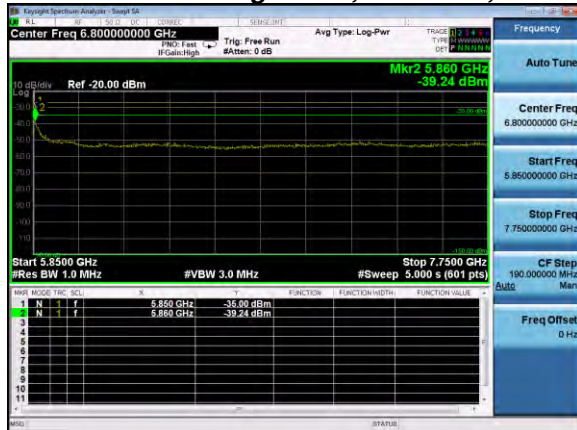

**Antenna A**

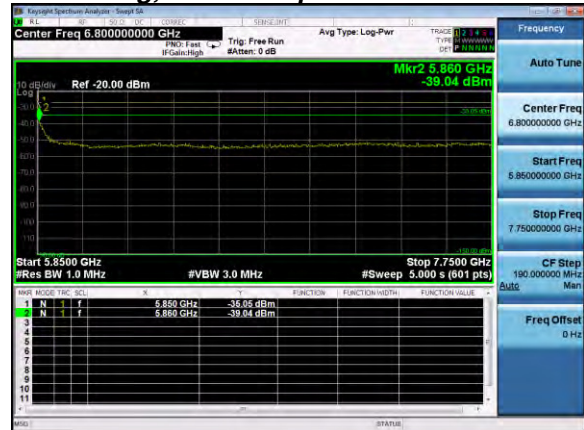

**Antenna B**

**Appendix B: Emission Test Results**

**Testing Laboratory:** Cisco Systems, Inc., 125 West Tasman Drive, San Jose, CA 95134, USA

**Radiated Emission Setup Diagram-Below 1G**

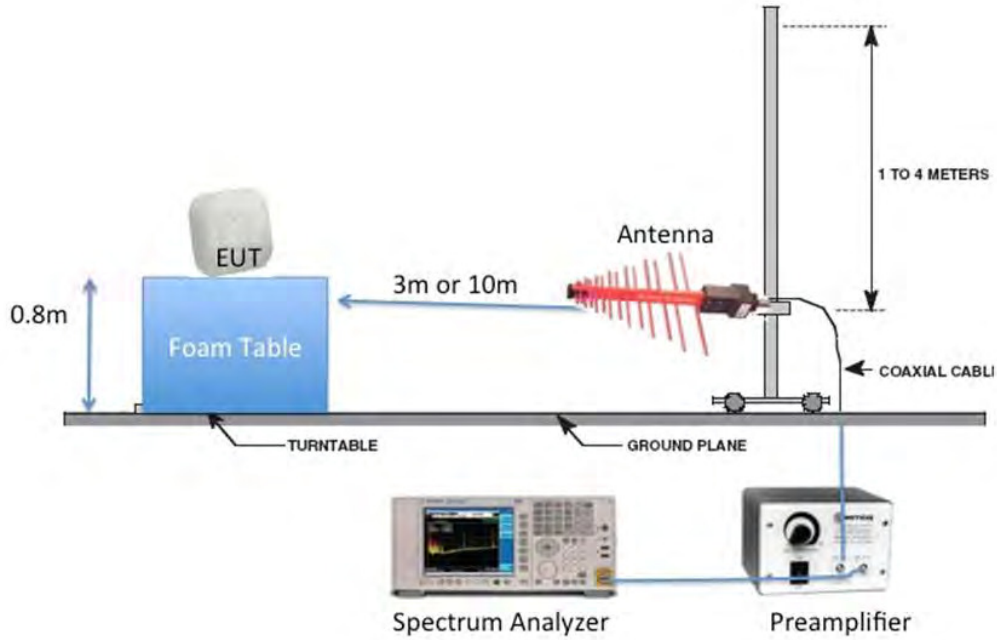

**Radiated Emission Setup Diagram-Above 1G**

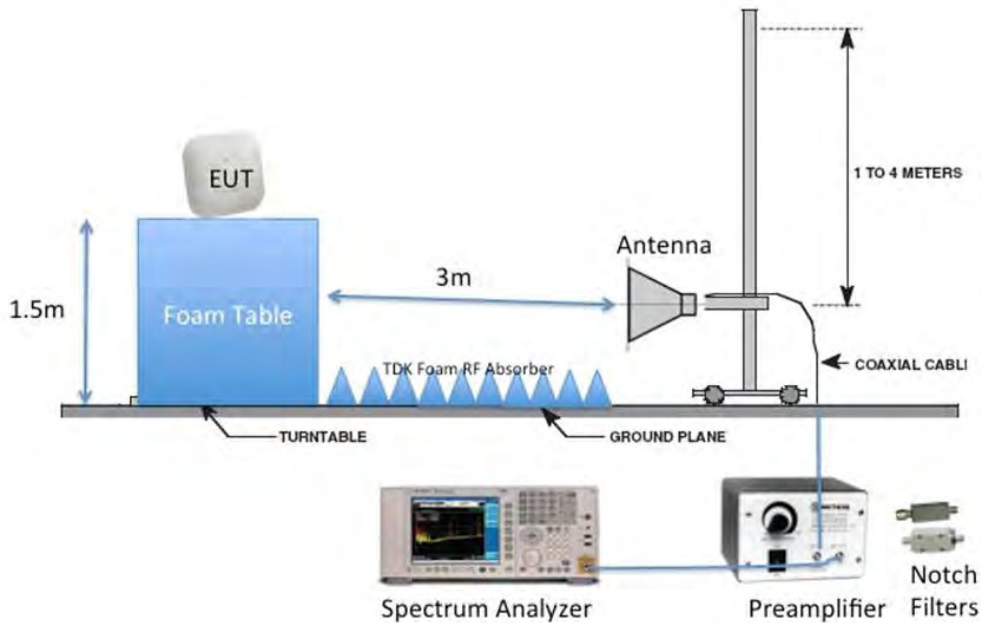





## B.1 Radiated Spurious Emissions

**15.407 (b) Undesirable emission limits.** Except as shown in paragraph (b) (7) of this section, the maximum emissions outside of the frequency bands of operation shall be attenuated in accordance with the following limits:

(4) For transmitters operating in the 5.725-5.85 GHz band: All emissions within the frequency range from the band edge to 10 MHz above or below the band edge shall not exceed an e.i.r.p. of -17 dBm/MHz; for frequencies 10 MHz or greater above or below the band edge, emissions shall not exceed an e.i.r.p. of -27 dBm/MHz.

(6) Unwanted emissions below 1 GHz must comply with the general field strength limits set forth in 15.209.

(7) The provisions of §15.205 apply to intentional radiators operating under this section.

(8) When measuring the emission limits, the nominal carrier frequency shall be adjusted as close to the upper and lower frequency band edges as the design of the equipment permits

**Ref.** ANSI C63.10: 2013 section 12.7.6 (peak) & 12.7.7.3 (average)

Using Vasona, configure the spectrum analyzer as shown below (be sure to enter all losses between the transmitter output and the spectrum analyzer). Place the radio in continuous transmit mode.

Span:	1GHz – 18 GHz/18GHz-26G/26GHz-40GHz
Reference Level:	80 dBuV
Attenuation:	10 dB
Sweep Time:	Coupled
Resolution Bandwidth:	1MHz
Video Bandwidth:	3 MHz for peak, 1 KHz for average
Detector:	Peak

Terminate the access Point RF ports with 50 ohm loads.

Maximize Turntable (find worst case table angle), Maximize Antenna (find worst case height)

Save 2 plots:     1) Average plot (Vertical and Horizontal), Limit= 54dBuV/m @3m  
                     2) Peak plot (Vertical and Horizontal), Limit = 74dBuV/m @3m

Place a marker at the end of the restricted band closest to the transmit frequency to show compliance. Also measure any emissions in the restricted bands.

This report represents the worst case data for all supported operating modes and antennas. There are no measurable emissions above 18 GHz.

System Number	Description	Samples	System under test	Support equipment
2	EUT	S03	<input checked="" type="checkbox"/>	<input type="checkbox"/>
	Support	S04	<input type="checkbox"/>	<input checked="" type="checkbox"/>

<b>Tested By :</b> Jose Aguirre	<b>Date of testing:</b> 01-Jan-16 - 03-Mar-16
<b>Test Result : PASS</b>	

See Appendix C for list of test equipment

**B.1.A Transmitter Radiated Spurious Emissions-Average worst case**

Frequency (MHz)	Mode	Data Rate (Mbps)	Spurious Emission Level (dBuV/m)	Limit (dBuV/m)	Margin (MHz)
5745	Non HT/VHT20, 6 to 54 Mbps	6	50.4	54.0	3.6
5755	HT/VHT40, M0 to M7, M0 to M9 1ss	m0	50.4	54.0	3.6
5775	HT/VHT80, M0 to M7, M0 to M9 1ss	m0x1	50.5	54.0	3.5
5785	Non HT/VHT20, 6 to 54 Mbps	6	50.3	54.0	3.7
5795	HT/VHT40, M0 to M7, M0 to M9 1ss	m0	50.4	54.0	3.6
5825	Non HT/VHT20, 6 to 54 Mbps	6	50.5	54.0	3.5



**B.1.A.1 Radiated Transmitter Spurs, 5745 MHz, Non HT/VHT20, 6 to 54 Mbps, Average (1-18GHz)**

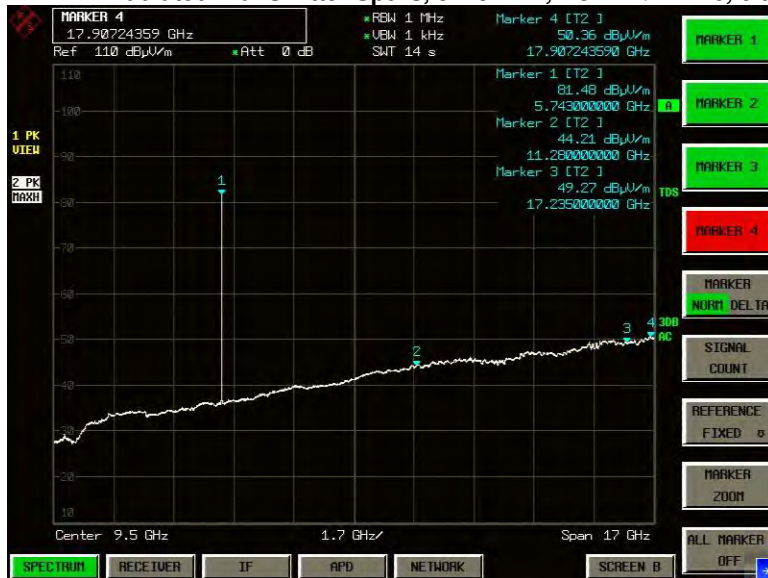

**B.1.A.2 Radiated Transmitter Spurs, 5755 MHz, HT/VHT40, M0 to M7, M0 to M9 1ss Average (1-18GHz)**

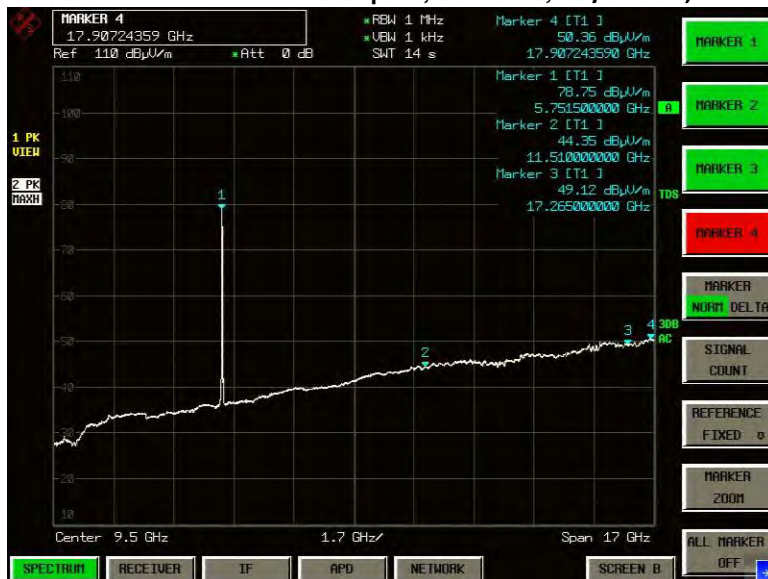



**B.1.A.3 Radiated Transmitter Spurs, 5775 MHz, HT/VHT80, M0 to M7, M0 to M9 1ss, Average (1-18GHz)**



**B.1.A.4 Radiated Transmitter Spurs, 5785 MHz, Non HT/VHT20, 6 to 54 Mbps, Average (1-18GHz)**





**B.1.A.5 Radiated Transmitter Spurs, 5795 MHz, HT/VHT40, M0 to M7, M0 to M9 1ss, Average (1-18GHz)**

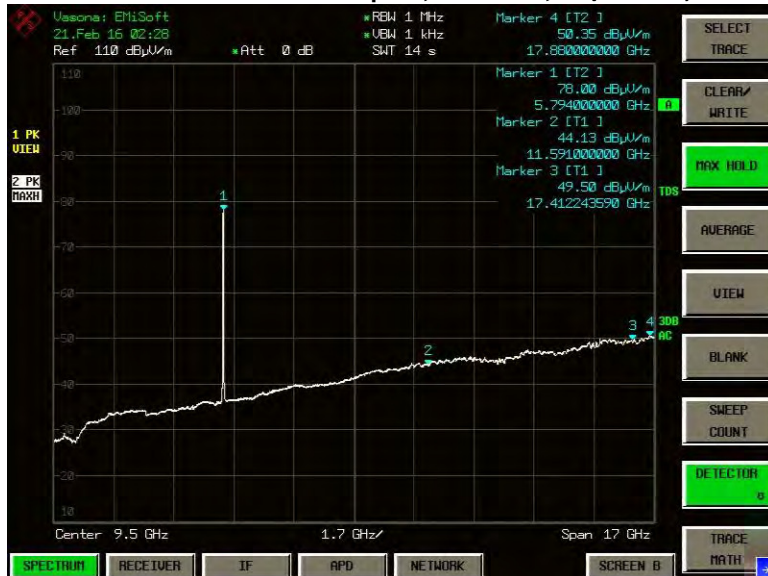

**B.1.A.6 Radiated Transmitter Spurs, 5825 MHz, Non HT/VHT20, 6 to 54 Mbps, Average (1-18GHz)**





**B.1.A.7 Radiated Transmitter Spurs, All rate, All modes, Average (18-26.5GHz)**



**B.1.A.8 Radiated Transmitter Spurs, All rate, All modes, Average (26.5- 40GHz)**





**B.1.P Transmitter Radiated Spurious Emissions-Peak worst case**

Frequency (MHz)	Mode	Data Rate (Mbps)	Spurious Emission Level (dBuV/m)	Limit (dBuV/m)	Margin (MHz)
5745	Non HT/VHT20, 6 to 54 Mbps	6	62.6	74.0	11.4
5755	HT/VHT40, M0 to M7, M0 to M9 1ss	m0	62.2	74.0	11.8
5775	HT/VHT80, M0 to M7, M0 to M9 1ss	m0x1	62.8	74.0	11.2
5785	Non HT/VHT20, 6 to 54 Mbps	6	61.6	74.0	12.4
5795	HT/VHT40, M0 to M7, M0 to M9 1ss	m0	62.3	74.0	11.7
5825	Non HT/VHT20, 6 to 54 Mbps	6	62.0	74.0	12.0

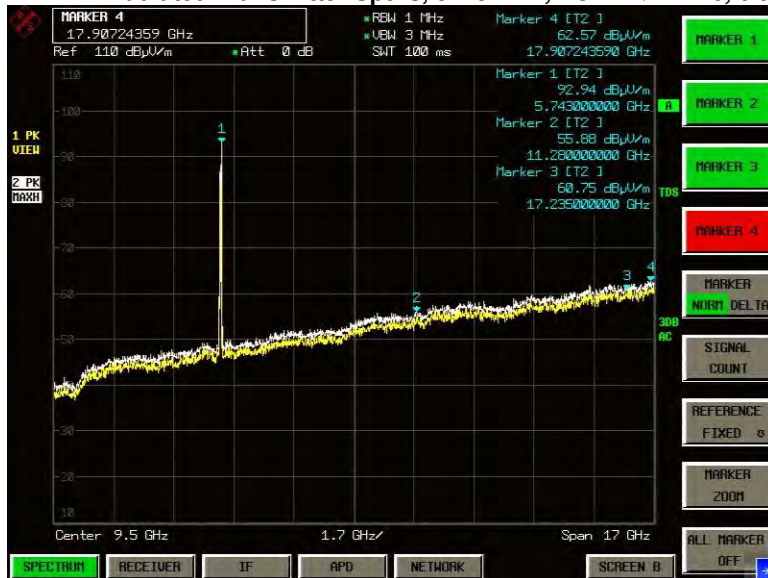

**B.1.P.1 Radiated Transmitter Spurs, 5745 MHz, Non HT/VHT20, 6 to 54 Mbps, (1-18GHz)**



**B.1.P.2 Radiated Transmitter Spurs, 5755 MHz, HT/VHT40, M0 to M7, M0 to M9 1ss, Peak (1-18GHz)**

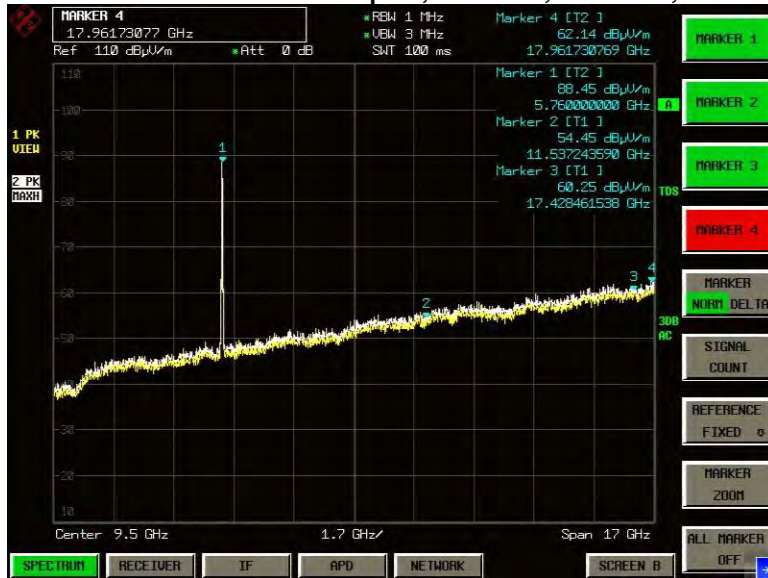





**B.1.P.3 Radiated Transmitter Spurs, 5775 MHz, VHT80, M0 to M9, M0 to M9 1.1, Peak (1-18GHz)**

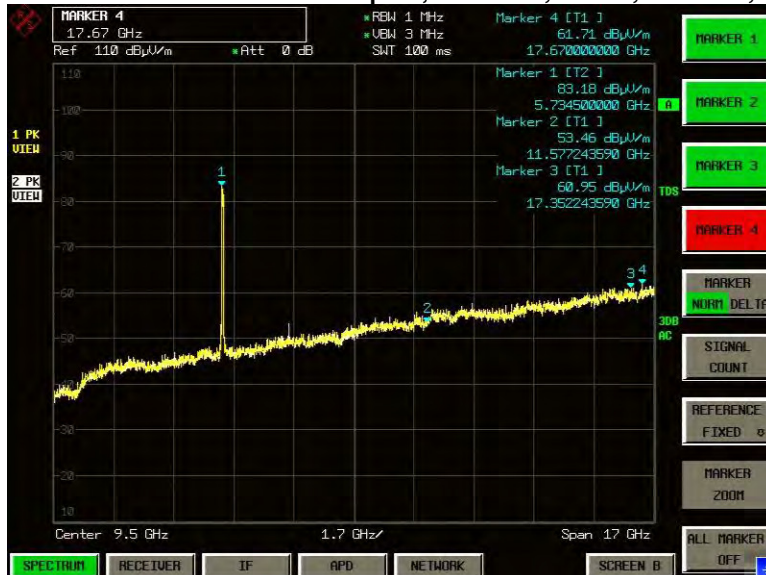

**B.1.P.4 Radiated Transmitter Spurs, 5785 MHz, Non HT/VHT20, 6 to 54 Mbps, Peak (1-18GHz)**

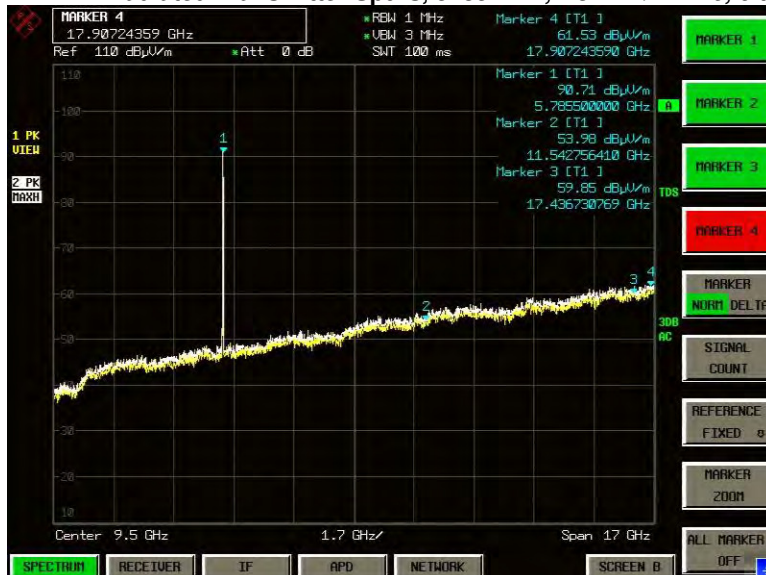



**B.1.P.5 Radiated Transmitter Spurs, 5795 MHz, HT/VHT40, M0 to M7, M0 to M9 1ss, Peak (1-18GHz)**

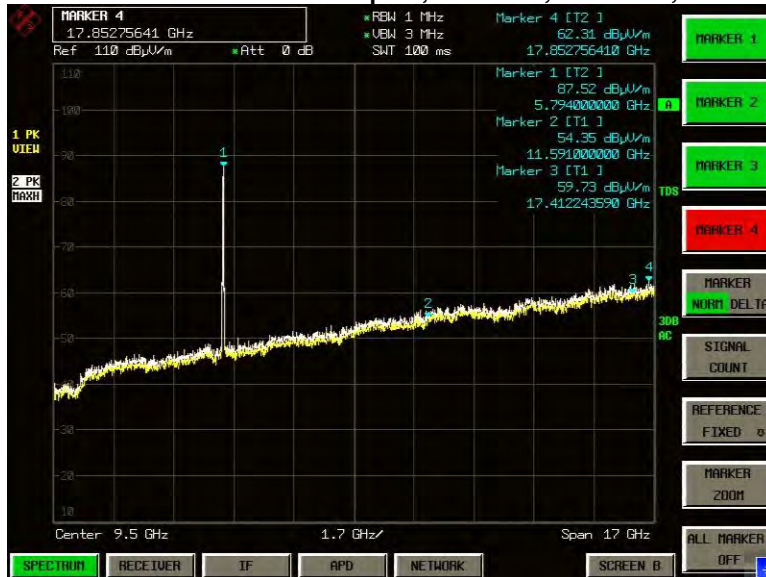

**B.1.P.6 Radiated Transmitter Spurs, 5825 MHz, Non HT/VHT20, 6 to 54 Mbps, Peak (1-18GHz)**

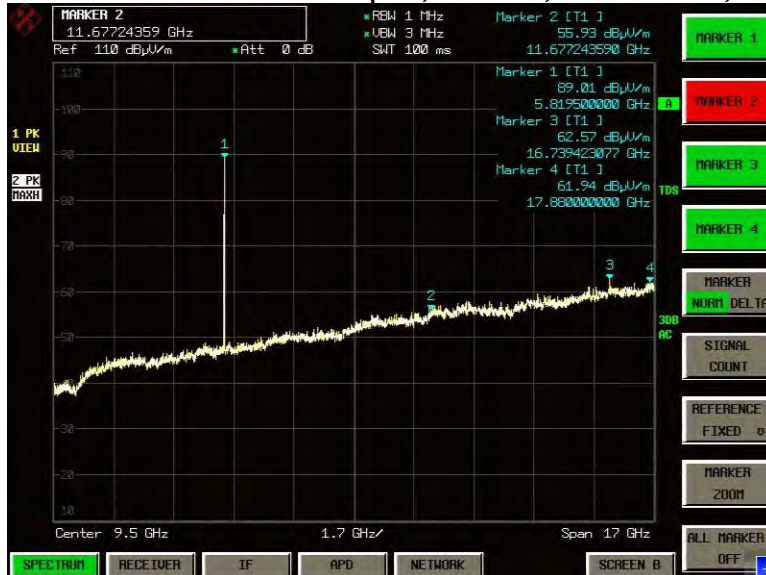



**B.1.P.7 Radiated Transmitter Spurs, All rate, All modes, Peak (18-26.5GHz)**



**B.1.P.8 Radiated Transmitter Spurs, All rate, All modes, Peak (26.5-40GHz)**





## B.2 Radiated Receiver Spurious Emissions

**RSS-GEN:** Receivers, are required to comply with the limits of spurious emissions as set out in this section. Receiver emission measurements are to be performed as per the normative test method referenced in Section 3.

For emissions at frequencies below 1 GHz, measurements shall be performed using a CISPR quasi-peak detector and the related measurement bandwidth. At frequencies above 1 GHz, measurements shall be performed using a linear average detector with a minimum resolution bandwidth of 1 MHz.

**Ref.** ANSI C63.10: 2013 section 12.7.6 (peak) & 12.7.7.3 (average)

Using Vasona, configure the spectrum analyzer as shown below (be sure to enter all losses between the transmitter output and the spectrum analyzer). Place the radio in continuous transmit mode.

Span:	1GHz – 18 GHz/18GHz-26G/26GHz-40GHz
Reference Level:	80 dBuV
Attenuation:	10 dB
Sweep Time:	Coupled
Resolution Bandwidth:	1MHz
Video Bandwidth:	3 MHz for peak, 1 KHz for average
Detector:	Peak

Terminate the access Point RF ports with 50 ohm loads.

Maximize Turntable (find worst case table angle), Maximize Antenna (find worst case height)

Save 2 plots: 1) Average plot (Vertical and Horizontal), Limit= 54dBuV/m @3m  
2) Peak plot (Vertical and Horizontal), Limit = 74dBuV/m @3m

Place a marker at the end of the restricted band closest to the transmit frequency to show compliance. Also measure any emissions in the restricted bands.

This report represents the worst case data for all supported operating modes and antennas. There are no measurable emissions above 18 GHz.

System Number	Description	Samples	System under test	Support equipment
1	EUT	S01	<input checked="" type="checkbox"/>	<input type="checkbox"/>
	Support	S02	<input type="checkbox"/>	<input checked="" type="checkbox"/>

<b>Tested By :</b> Jose Aguirre	<b>Date of testing:</b> 01-Jan-16 - 22-Feb-16
<b>Test Result : PASS</b>	

See Appendix C for list of test equipment



## B.2.A Receiver Radiated Spurious Emissions Average Measurements

### B.2.A.1 Radiated Receiver Spurs, All rates, All Mode, Average (1-18GHz)



### B.2.A.2 Radiated Receiver Spurs, All rates, All Mode, Average (18-26.5GHz)





**B.2.A.3 Radiated Receiver Spurs, All rates, All Mode, Average (26.5-40GHz)**

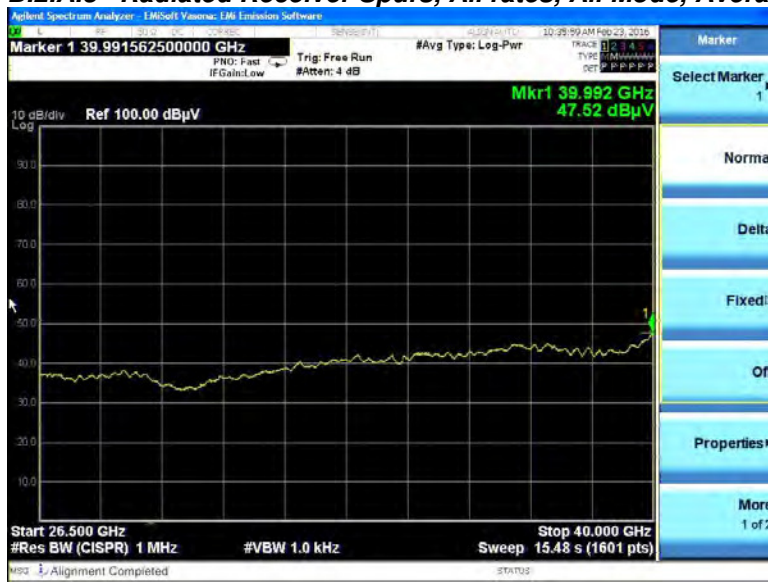



## B.2.P Receiver Radiated Spurious Emissions Peak Measurements

### B.2.P.1 Radiated Receiver Spurs, All rates, All Mode, Peak (1-18GHz)



### B.2.P.2 Radiated Receiver Spurs, All rates, All Mode, Peak (18-26.5GHz)





**B.2.P.3 Radiated Receiver Spurs, All rates, All Mode, Peak (26.5-40GHz)**







### B.3 Radiated Emissions 30MHz to 1GHz

**15.205 / 15.209 / RSS-Gen:**

Radiated emissions which fall in the restricted bands, as defined in Section 15.205(a), and RSS-Gen sec 8.10 must also comply with the radiated emission limits specified in Section 15.209(a) (see Section 15.205(c)) and RSS-Gen sec 8.9

**Ref.** ANSI C63.10: 2013 section 6.5

Using Vasona, configure the spectrum analyzer as shown below (be sure to enter all losses between the transmitter output and the spectrum analyzer). Place the radio in continuous transmit mode.

Span:	30MHz – 1GHz
Reference Level:	80 dBuV
Attenuation:	10 dB
Sweep Time:	Coupled
Resolution Bandwidth:	100kHz
Video Bandwidth:	300kHz
Detector:	Peak for Pre-scan, Quasi-Peak

Compliance shall be determined using CISPR quasi-peak detection; however, peak detection is permitted as an alternative to quasi-peak detection.

Terminate the access Point RF ports with 50 ohm loads.

Maximize Turntable (find worst case table angle), Maximize Antenna (find worst case height)

This report represents the worst case data for all supported operating modes and antennas.

System Number	Description	Samples	System under test	Support equipment
1	EUT	S01	<input checked="" type="checkbox"/>	<input type="checkbox"/>
	Support	S02	<input type="checkbox"/>	<input checked="" type="checkbox"/>

<b>Tested By :</b> Jose Aguirre	<b>Date of testing:</b> 10-Feb-16 to 22-Feb-16
<b>Test Result : PASS</b>	

See Appendix C for list of test equipment



**Graphical Test Results**

Note that the data displayed on the plots detailed in this appendix were measured using a 'Peak Detector'. Please refer to the results table for the detectors used during formal measurements

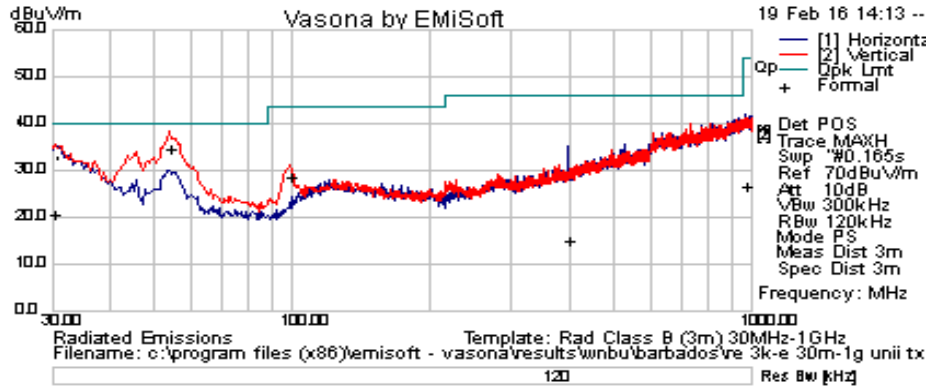

**Test Results**

Frequency MHz	Raw dBuV	Cable Loss	AF dB	Level dBuV/m	Measurement Type	P ol	Hgt cm	Azt Deg	Limit dBuV/m	Margin dB	Pass /Fail
967.505	0.54	2.96	23.1	26.6	Quasi Max	H	389	52	54	-27.4	Pass
53.998	26.59	0.7	7.35	34.65	Quasi Max	V	110	142	40	-5.35	Pass
98.87	18.09	0.93	9.89	28.92	Quasi Max	V	157	194	43.5	-14.58	Pass
398.115	-1.71	1.89	15.06	15.24	Quasi Max	H	326	200	46	-30.76	Pass
30.485	-0.96	0.49	21.27	20.81	Quasi Max	V	355	350	40	-19.19	Pass



## B.4 AC Conducted Emissions

**FCC 15.207** Except when the requirements applicable to a given device state otherwise, for any radio apparatus equipped to operate from the public utility AC power supply, either directly or indirectly (such as with a battery charger), the radio frequency voltage of emissions conducted back onto the AC power lines in the frequency range of 0.15 MHz to 30 MHz shall not exceed the limits shown in the table in these sections. The more stringent limit applies at the frequency range boundaries.

Measurement Procedure  
 Accordance with ANSI C63.10:2013 section 6.2

Using Vasona, configure the spectrum analyzer as shown below (be sure to enter all losses between the transmitter output and the spectrum analyzer). Place the radio in continuous transmit mode.

Span: 150 KHz – 30 MHz  
 Attenuation: 10 dB  
 Sweep Time: Coupled  
 Resolution Bandwidth: 9 KHz  
 Video Bandwidth: 30 KHz  
 Detector: Quasi-Peak / Average

System Number	Description	Samples	System under test	Support equipment
1	EUT	S01	<input checked="" type="checkbox"/>	<input type="checkbox"/>
	Support	S02	<input type="checkbox"/>	<input checked="" type="checkbox"/>

<b>Tested By :</b> Jose Aguirre	<b>Date of testing:</b> 10-Feb-16 to 22-Feb-16
<b>Test Result : PASS</b>	

See Appendix C for list of test equipment



**Graphical Test Results**

Note that the data displayed on the plots detailed in this appendix were measured using a 'Peak Detector'. Please refer to the results table for the detectors used during formal measurements

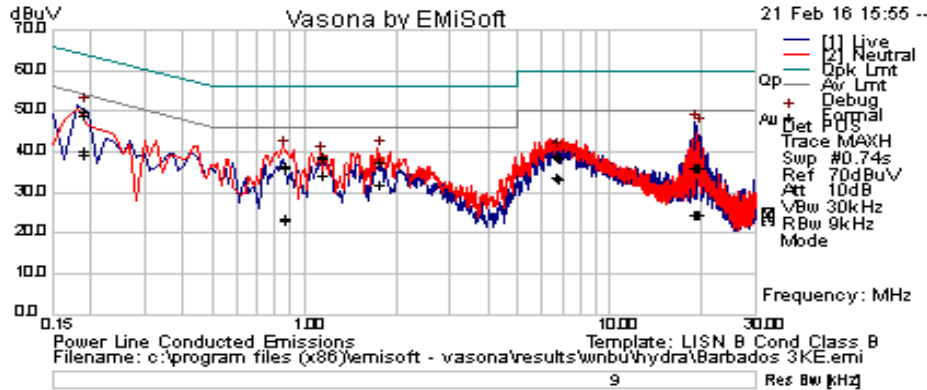

**Test Results**

Frequency MHz	Raw dBuV	Cable Loss	Factors dB	Level dBuV	Measurement Type	Line	Limit dBuV	Margin dB	Pass /Fail
0.857757	16.19	19.91	0.03	36.14	Quasi Peak	Live	56	-19.86	Pass
0.187244	29.09	20.91	0.06	50.06	Quasi Peak	Live	64.16	-14.1	Pass
19.007406	15.87	20.3	0.2	36.37	Quasi Peak	Live	60	-23.63	Pass
1.755417	17.64	19.9	0.03	37.57	Quasi Peak	Live	56	-18.43	Pass
19.383573	15.92	20.3	0.2	36.42	Quasi Peak	Live	60	-23.58	Pass
6.724028	18.68	20.01	0.07	38.76	Quasi Peak	Live	60	-21.24	Pass
1.131699	18.77	19.9	0.04	38.71	Quasi Peak	Live	56	-17.29	Pass
19.029708	16	20.3	0.2	36.5	Quasi Peak	Neutral	60	-23.5	Pass
0.856911	16.86	19.91	0.03	36.81	Quasi Peak	Neutral	56	-19.19	Pass
19.384527	15.97	20.3	0.2	36.47	Quasi Peak	Neutral	60	-23.53	Pass
0.190178	28.11	20.9	0.06	49.06	Quasi Peak	Neutral	64.03	-14.97	Pass
1.133571	19.28	19.9	0.04	39.22	Quasi Peak	Neutral	56	-16.78	Pass
1.756893	17.73	19.9	0.03	37.66	Quasi Peak	Neutral	56	-18.34	Pass
6.712994	19.08	20.01	0.07	39.16	Quasi Peak	Neutral	60	-20.84	Pass
0.857757	4.02	19.91	0.03	23.97	Average	Live	46	-22.03	Pass
0.187244	19.33	20.91	0.06	40.3	Average	Live	54.16	-13.86	Pass
19.007406	4.14	20.3	0.2	24.65	Average	Live	50	-25.35	Pass
1.755417	12.41	19.9	0.03	32.34	Average	Live	46	-13.66	Pass
19.383573	4.45	20.3	0.2	24.95	Average	Live	50	-25.05	Pass
6.724028	13.39	20.01	0.07	33.47	Average	Live	50	-16.53	Pass
1.131699	14.43	19.9	0.04	34.37	Average	Live	46	-11.63	Pass
19.029708	4.05	20.3	0.2	24.55	Average	Neutral	50	-25.45	Pass
0.856911	3.62	19.91	0.03	23.57	Average	Neutral	46	-22.43	Pass
19.384527	4.22	20.3	0.2	24.72	Average	Neutral	50	-25.28	Pass
0.190178	18.8	20.9	0.06	39.75	Average	Neutral	54.03	-14.28	Pass
1.133571	14.69	19.9	0.04	34.63	Average	Neutral	46	-11.37	Pass
1.756893	12.41	19.9	0.03	32.34	Average	Neutral	46	-13.66	Pass
6.712994	13.86	20.01	0.07	33.94	Average	Neutral	50	-16.06	Pass

**Photographs of setup**

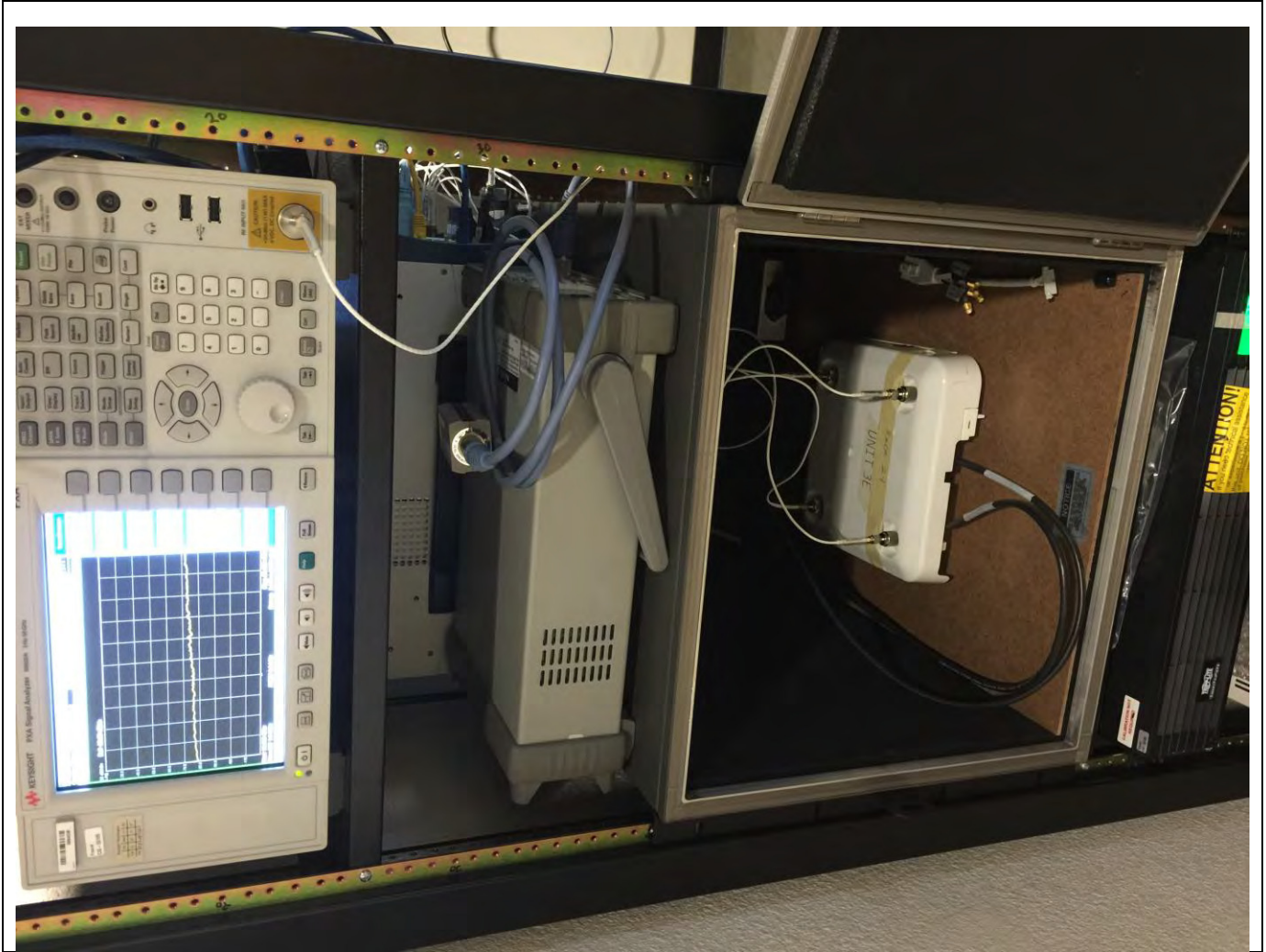

**Title: Conducted Test Setup**

This is a dual band 2.4GHz / 5GHz device. All ports in this test set up photo are connected as all testing is automated. Section 2.6 of this test report given an overview of the different Tx antenna combinations used by this device.

**AIR-AP3802E-B-K9 AC Mains Conducted Emissions setup**



**AIR-AP3802E-B-K9 Radiated Emissions setup 30MHz – 1GHz**

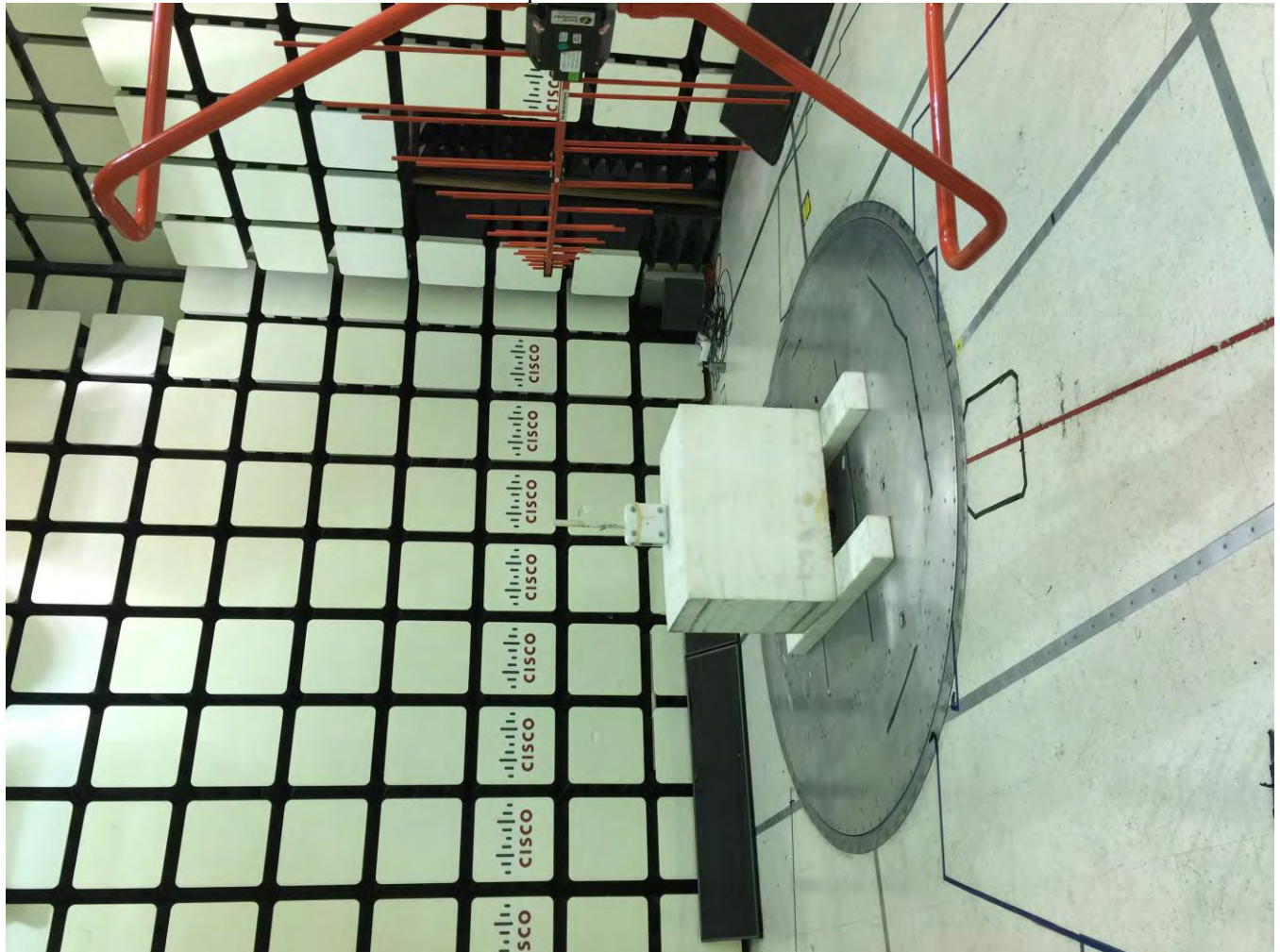

**AIR-AP3802E-B-K9 Radiated Emissions setup above 1GHz**

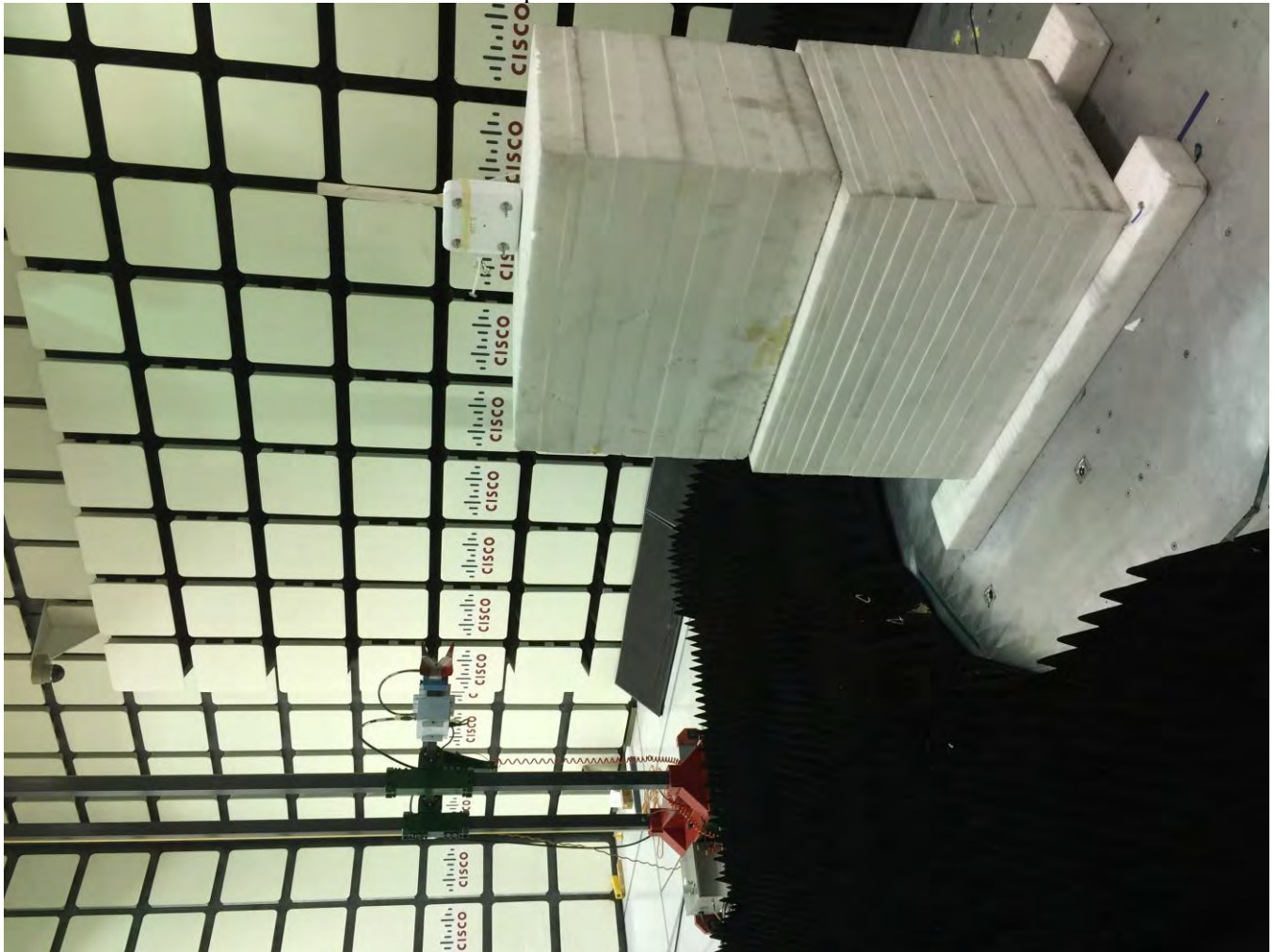





**Appendix C: List of Test Equipment Used to perform the test**

Equip#	Manufacturer/ Model	Description	Last Cal	Next Due	Test Item
<b>Test Equipment used for Radiated Emissions</b>					
CIS005691	NSP1800-25-S1 Miteq	Broadband Preampifier (1-18GHz)	25-Jun-15	25-Jun-16	B.1
CIS008448	NSA 5m Chamber Cisco	NSA 5m Chamber	9-Oct-15	9-Oct-16	B.2
CIS021117	UFB311A-0-2484-520520 Micro-Coax	RF Coaxial Cable, to 18GHz, 248.4 in	24-Aug-15	24-Aug-16	B.1, B.2
CIS034075	RSG 2000 Schaffner	Reference Spectrum Generator, 1-18GHz	Cal Not Required	Cal Not Required	B.1
CIS035284	3117 ETS-Lindgren	Double Ridged Waveguide Horn Antenna	30-Sep-15	30-Sep-16	B.1
CIS037236	50CB-015 JFW	GPIB Control Box	Cal Not Required	Cal Not Required	B.1
CIS040597	Above 1GHz Site Cal Cisco	Above 1GHz Cispr Site Verification	25-Sep-15	25-Sep-16	B.1
CIS041979	1840 Cisco	18-40GHz EMI Test Head/Verification Fixture	13-Jul-15	13-Jul-16	B.1
CIS042266	JB1 Sunol Sciences	Combination Antenna	21-Apr-15	21-Apr-16	B.2
CIS044940	ESU40 Rohde & Schwarz	EMI Test Receiver, 20Hz-40GHz	2-Nov-15	2-Nov-16	B.1
CIS054230	iBTHP-5-DB9 Newport	5 inch Temp/RH/Press Sensor w/20ft cable	10-Feb-16	10-Feb-17	B.1, B.2

<b>Test Equipment used for AC Mains Conducted Emissions</b>					
Equip No	Model Manufacturer	Description	Last Cal	Next Cal	Test Item
CIS002464	FCC-801-M2-16 Fischer Custom Communications	CDN, 2-LINE, 16A	12-Mar-15	12-Mar-16	B.3
CIS049532	H785-150K-50-21378 TTE	High Pass Filter	8-May-15	8-May-16	B.3
CIS020913	FCC-LISN-PA-NEMA-5-15 Fischer Custom Communications	AC Adapter	8-May-15	8-May-16	B.3
CIS007704	FCC-LISN-50/250-50-2-01 Fischer Custom Communications	LISN	8-May-15	8-May-16	B.3
CIS008185	FCC-450B-2.4-N Fischer Custom Communications	Instrumentation Limiter	28-Jul-15	28-Jul-16	B.3
CIS051756	5-T-MB Bird	5W 50 Ohm BNC Termination 4GHz	6-Aug-15	6-Aug-16	B.3
CIS049563	Sucoflex 106A Huber + Suhner	N Type Cable 18GHz	24-Aug-15	24-Aug-16	B.3
CIS021117	UFB311A-0-2484-520520 Micro-Coax	RF Coaxial Cable, to 18GHz, 248.4 in	24-Aug-15	24-Aug-16	B.3
CIS044940	ESU40 Rohde & Schwarz	EMI Test Receiver, 20Hz-40GHz	2-Nov-15	2-Nov-16	B.3
CIS054647	33-605 Stanley	10meter Measuring Tape	Cal not required	Cal not required	B.3
CIS018963	CNE V York	Comparison Noise Emitter, 30 - 1000MHz	Cal not required	Cal not required	B.3

<b>Test Equipment used for RF Conducted Tests</b>					
Equip No	Model Manufacturer	Description	Last Cal	Next Cal	Test Item



CIS050721	N9030A Keysight	PXA Signal Analyzer	13-Apr-15	13-Apr-16	A1 thru A6
CIS054662	SF18-S1S1-36 MegaPhase	SMA 36" cable	24-Sep-15	24-Sep-16	A1 thru A6
CIS054663	F120-S1S1-48 MegaPhase	SMA 48" Cable	25-Sep-15	25-Sep-16	A1 thru A6
CIS054665	RA08-S1S1-24 MegaPhase	SMA 24" Cable	25-Sep-15	25-Sep-16	A1 thru A6
CIS054666	RA08-S1S1-18 MegaPhase	SMA 18" Cable	25-Sep-15	25-Sep-16	A1 thru A6
CIS054667	RA08-S1S1-18 MegaPhase	SMA 18" Cable	25-Sep-15	25-Sep-16	A1 thru A6
CIS054668	RA08-S1S1-18 MegaPhase	SMA 18" Cable	25-Sep-15	25-Sep-16	A1 thru A6
CIS054669	RA08-S1S1-18 MegaPhase	SMA 18" Cable	25-Sep-15	25-Sep-16	A1 thru A6
CIS054670	RA08-S1S1-12 MegaPhase	SMA 12" Cable	25-Sep-15	25-Sep-16	A1 thru A6
CIS054671	RA08-S1S1-12 MegaPhase	SMA 12" Cable	25-Sep-15	25-Sep-16	A1 thru A6
CIS054672	RA08-S1S1-12 MegaPhase	SMA 12" Cable	25-Sep-15	25-Sep-16	A1 thru A6
CIS054673	RA08-S1S1-12 MegaPhase	SMA 12" Cable	25-Sep-15	25-Sep-16	A1 thru A6
CIS054674	RA08-S1S1-12 MegaPhase	SMA 12" Cable	25-Sep-15	25-Sep-16	A1 thru A6
CIS054675	RA08-S1S1-12 MegaPhase	SMA 12" Cable	25-Sep-15	25-Sep-16	A1 thru A6
CIS054677	RA08-S1S1-12 MegaPhase	SMA 12" Cable	25-Sep-15	25-Sep-16	A1 thru A6
CIS054678	RA08-S1S1-12 MegaPhase	SMA 12" Cable	25-Sep-15	25-Sep-16	A1 thru A6
CIS054686	NI PXI-2796 National Instruments	Plug-in switch module	6-Oct-15	6-Oct-16	A1 thru A6
CIS055094	PXI-1042 National Instruments	Chassis	Cal Not Required	Cal Not Required	A1 thru A6
CIS055117	RFLT2WDC40G RF Lambda	2 Way 40GHz Splitter	11-Nov-15	11-Nov-16	A1 thru A6
CIS055166	RFLT4WDC40GK RF Lambda	4 Way Power Divider 40GHz	23-Nov-15	23-Nov-16	A1 thru A6
CIS054656	BRC50705-02 Micro-Tronics	Band Reject Filter	24-Sep-15	24-Sep-16	A1 thru A6
CIS054655	BRC50704-02 Micro-Tronics	Notch Filter, SB:5.470-5.725GHz, to 12GHz	24-Sep-15	24-Sep-16	A1 thru A6
CIS054654	BRC50703-02 Micro-Tronics	Notch Filter, SB:5.150-5.350GHz, to 11GHz	24-Sep-15	24-Sep-16	A1 thru A6
CIS054653	BRM50702-02 Micro-Tronics	Notch Filter, SB:2.400-2.500GHz, to 18GHz	24-Sep-15	24-Sep-16	A1 thru A6
CIS054637	BWS30-W2/ Aeroflex	SMA 30dB Attenuator	02-June-15	02-June-16	A1 thru A6
CIS054636	BWS20-W2/ Aeroflex	20dB SMA Attenuator	02-June-15	02-June-16	A1 thru A6



## Appendix E: Abbreviation Key and Definitions

The following table defines abbreviations used within this test report.

Abbreviation	Description	Abbreviation	Description
EMC	Electro Magnetic Compatibility	°F	Degrees Fahrenheit
EMI	Electro Magnetic Interference	°C	Degrees Celsius
EUT	Equipment Under Test	Temp	Temperature
ITE	Information Technology Equipment	S/N	Serial Number
TAP	Test Assessment Schedule	Qty	Quantity
ESD	Electro Static Discharge	emf	Electromotive force
EFT	Electric Fast Transient	RMS	Root mean square
EDCS	Engineering Document Control System	Qp	Quasi Peak
Config	Configuration	Av	Average
CIS#	Cisco Number (unique identification number for Cisco test equipment)	Pk	Peak
Cal	Calibration	kHz	Kilohertz (1x10 <sup>3</sup> )
EN	European Norm	MHz	MegaHertz (1x10 <sup>6</sup> )
IEC	International Electro technical Commission	GHz	Gigahertz (1x10 <sup>9</sup> )
CISPR	International Special Committee on Radio Interference	H	Horizontal
CDN	Coupling/Decoupling Network	V	Vertical
LISN	Line Impedance Stabilization Network	dB	decibel
PE	Protective Earth	V	Volt
GND	Ground	kV	Kilovolt (1x10 <sup>3</sup> )
L1	Line 1	μV	Microvolt (1x10 <sup>-6</sup> )
L2	Line2	A	Amp
L3	Line 3	μA	Micro Amp (1x10 <sup>-6</sup> )
DC	Direct Current	mS	Milli Second (1x10 <sup>-3</sup> )
RAW	Uncorrected measurement value, as indicated by the measuring device	μS	Micro Second (1x10 <sup>-6</sup> )
RF	Radio Frequency	μS	Micro Second (1x10 <sup>-6</sup> )
SLCE	Signal Line Conducted Emissions	m	Meter
Meas dist	Measurement distance	Spec dist	Specification distance
N/A or NA	Not Applicable	SL	Signal Line (or Telecom Line)
P	Power Line	L	Live Line
N	Neutral Line	R	Return
S	Supply	AC	Alternating Current



**End**