



M. Flom Associates, Inc. - Global Compliance Center

3356 North San Marcos Place, Suite 107, Chandler, Arizona 85225-7176

www.mflom.com general@mflom.com (480) 926-3100, FAX: 926-3598

VERIFICATION
(UNINTENTIONAL RADIATOR)

of

MODEL: AIR-USB340

FCC ID: LDK102041

to

FEDERAL COMMUNICATIONS COMMISSION

RULE PART 15, SUBPART B - UNINTENTIONAL RADIATORS

CLASS B LIMITS.

DATE OF REPORT: September 12, 2000

ON THE BEHALF OF THE APPLICANT:

Cisco Systems Inc

AT THE REQUEST OF:

P.O. 394296

Cisco Systems Inc
3875 Embassy Parkway
Akron, OH 44333

Attention of:

David A. Case, NCE, Senior Compliance Engineer
(330) 664-7396; FAX: -7301
Email: davecase@cisco.com

SUPERVISED BY:

Morton Flom, P. Eng.

TABLE OF CONTENTS

<u>RULE</u>	<u>DESCRIPTION</u>	<u>PAGE</u>
	Test Report	1
2.947	General Information	3
15.109	Spurious Emissions (Radiated)	6

PAGE NO. 1 of 15.

Required information per ISO/IEC Guide 25-1990, paragraph 13.2:

- a) TEST REPORT
- b) Laboratory: M. Flom Associates, Inc.
(FCC: 31040/SIT) 3356 N. San Marcos Place, Suite 107
(Canada: IC 2044) Chandler, AZ 85225
- c) Report Number: d0090017
- d) Client: Cisco Systems Inc
3875 Embassy Parkway
Akron, OH 44333
- e) Identification: AIR-USB340
FCC ID: LDK102041
Description: Spread Spectrum Radio
- f) EUT Condition: Not required unless specified in individual tests.
- g) Report Date: September 12, 2000
EUT Received: July 20, 2000
- h, j, k): As indicated in individual tests.
- i) Sampling method: No sampling procedure used.
- l) Uncertainty: In accordance with MFA internal quality manual.
- m) Supervised by: 
Morton Flom, P. Eng.
- n) Results: The results presented in this report relate only to the item tested.
- o) Reproduction: This report must not be reproduced, except in full, without written permission from this laboratory.

M. Flom Associates, Inc. is accredited by the American Association for Laboratory Association (A2LA) as shown in the scope below.



THE AMERICAN ASSOCIATION FOR LABORATORY ACCREDITATION

ACCREDITED LABORATORY

A2LA has accredited

M. FLOM ASSOCIATES, INC.
Chandler, AZ

for technical competence in the field of

Electrical (EMC) Testing

The accreditation covers the specific tests and types of tests listed on the agreed scope of accreditation. This laboratory meets the requirements of ISO/IEC Guide 25-1990 "General Requirements for the Competence of Calibration and Testing Laboratories" (equivalent to relevant requirements of the ISO 9000 series of standards) and any additional program requirements in the identified field of testing.

Presented this 24th day of November, 1998.



Peter Abjorn
President
For the Accreditation Council
Certificate Number 1008.01
Valid to December 31, 2000

For tests or types of tests to which this accreditation applies, please refer to the laboratory's Electrical (EMC) Scope of Accreditation



American Association for Laboratory Accreditation

SCOPE OF ACCREDITATION TO ISO/IEC GUIDE 25-1990 AND EN 45001

M. FLOM ASSOCIATES, INC.
Electronic Testing Laboratory
3356 North San Marcos Place, Suite 107
Chandler, AZ 85225
Morton Flom Phone: 480 926 3100

ELECTRICAL (EMC)

Valid to: December 31, 2000 Certificate Number: 1008-01

In recognition of the successful completion of the A2LA evaluation process, accreditation is granted to this laboratory to perform the following electromagnetic compatibility tests:

Tests	Standard(s)
RF Emissions	FCC Part 15 (Subparts B and C) using ANSI C63 4-1992; CISPR 11; CISPR 13; CISPR 14; CISPR 22; EN 55011; EN 55013; EN 55014; EN 55022; EN 50081-1; EN 50081-2; FCC Part 18; ICES-003; AS/NZS 1044; AS/NZS 1053; AS/NZS 3548; AS/NZS 4251.1; CNS 13438
RF Immunity	EN 50082-1; EN 50082-2; AS/NZS 4251.1
Radiated Susceptibility	EN 61000-4-3; ENV 50140; ENV 50204; IEC 1000-4-3; IEC 801-3
ESD	EN 61000-4-2; IEC 1000-4-2; IEC 801-2
EFT	EN 61000-4-4; IEC 1000-4-4; IEC 801-4
Surge	EN 61000-4-5; ENV 50142; IEC 1000-4-5; IEC 801-5
47 CFR (FCC)	2, 21, 22, 23, 24, 74, 80, 87, 90, 95, 97

Revised 2/2/2000

Peter Abjorn

5301 Buckeystown Pike, Suite 350 • Frederick, MD 21704-8370 • Phone: 301 644 3248 • Fax: 301 662 2974

"This laboratory is accredited by the American Association for Laboratory Accreditation (A2LA) and the results shown in this report have been determined in accordance with the laboratory's terms of accreditation unless stated otherwise in the report."

Should this report contain any data for tests for which we are not accredited, or which have been undertaken by a subcontractor that is not A2LA accredited, such data would not covered by this laboratory's A2LA accreditation.

PAGE NO. 3 of 15.

GENERAL INFORMATION

Part 2.947:

MEASUREMENT PROCEDURE

15.101:

AUTHORIZATION OF UNINTENTIONAL RADIATORS

GUIDE:

MEASUREMENT PROCEDURE ANSI C63.4-1992

DESCRIPTION OF MEASUREMENT FACILITIES:

FILE: 31040/SIT

A description of the measurement facilities was filed with the Commission and was found to be in compliance with the requirements of Section 2.948, by letter dated March 3, 1997. All pertinent changes will be reported to the Commission by up-date prior to March 2000.

NOTE: The equipment under test was connected with all accessories as normally supplied, and was operated in accordance with the manufacturer's specifications.

The data herein is to indicate that the equipment under test has been found to comply with the FCC Rules Part 15 Subpart B Class B Limits.

DATE OF TESTS:

July 2000

PERSONNEL:

STAFF AT M. FLOM ASSOCIATES, INC.

NOTE: This report must not be reproduced, except in full, without written permission from this laboratory.

PAGE NO. 4 of 15.

TECHNICAL REPORT

1. (a) NAME AND ADDRESS OF MANUFACTURER:

Cisco Systems Inc
170 West Tasman Drive
San Jose, CA 95134-1706

(b) MODEL NO:

AIR-USB340

(c) TRADE NAME:

Cisco

(d) EQUIPMENT UNDER TEST (EUT) DESCRIPTION:

Spread Spectrum Radio

(e) THE EUT'S NORMAL OPERATING LOCATION IS:

Module

2. ACCESSORIES:

<u>Qty</u>	<u>Type</u>	<u>Make, Model</u>	<u>S/N</u>	<u>FCC ID</u>
------------	-------------	--------------------	------------	---------------

N/A

3. CABLES:

Qty	Type	Length, m	Shield	Shielded Hood	Ferrite
N/A					

FOR ALL TESTS:

- a. Interface cables were positioned so as to maximize the emissions during testing.
- b. Cables draped and bundled individually.
- c. Cables were arranged and moved in all planes to maximize emissions.
- d. External monitor connected (a) to auxiliary AC outlet and then (b) to floor-mounted AC outlet.
- e. Photographs show worst case conditions.

In accordance with ANSI C63.4-1992/2000, section 6.1.9, and unless otherwise indicated in the specific measurement results, the ambient temperature of the actual EUT was maintained within the range of 10° to 40°C (50° to 104 °F) unless the particular equipment requirements specify testing over a different temperature range. Also, unless otherwise indicated, the humidity levels were in the range of 10% to 90% relative humidity.

4. MODIFICATIONS:

(none)

15.31: MEASUREMENT STANDARD & PROCEDURE:

- ___ IEEE STANDARD 187 WAS USED AS A GUIDE.
- ___ FCC MEASUREMENT PROCEDURE MP-1
- x ANSI 63.4 (1992/2000) "Methods of measurement of radio-noise emissions from low-voltage electrical and electronic equipment in the range of 9 kHz to 40 GHz."
- ___

PAGE NO. 6 of 15.

NAME OF TEST: Radiated Spurious Emissions

SPECIFICATION:

15.109: Radiated Interference Limits
15.209: Radiated Emission Limits; General Requirements
15.33: Frequency Range of Radiated Measurements
80.217: Suppression of Interference Aboard Ships

GUIDE: ANSI C63.4-1992/2000

TEST EQUIPMENT: See attached test setup

TEST CONFIGURATION OF EUT:

1. The equipment was installed in a typical system and configured in accordance with the manufacturer's instructions. It was also operated in a manner which is representative of the typical usage for the EUT.
2. The equipment and I/O cable(s) were re-arranged to maximize each emission. For each change in configuration, the system was rotated through 360°. The antenna height was changed from one to six meters. Both horizontal and vertical polarization scans were used. The worst case is here reported.
3. For EUTs normally operated on top of a table, tests were performed with the EUT on a rotating non-conducting table top of size 1.0 by 1.5 meters, approximately 1.0 meter above the ground plane.
4. EUTs normally placed on the floor, tests were performed with the EUT on a rotating non-conducting platform, approximately 15 cm above the ground plane.

PAGE NO. 7 of 15.

NAME OF TEST: Radiated Spurious Emissions (Continued)

TEST PROCEDURE:

1. For AC powered equipment, the EUT was connected to the Public Utility Power Line through a Singer 94641-1 Line Impedance Stabilization Network (LISN), (50 μ H).
2. The test configuration consisted of the aforementioned equipment and peripherals, using ANSI C63.4-1992/2000.
3. Radiation emission tests were performed on all possible combinations.
4. All measurements were performed manually. No automatic scan was used.
5. Measurements were made with the EUT:
 - A. POWERED ON and awaiting data input/output (quiescent mode)
 - B. Receiving/sending data in a typical operation.
6. Each emission was maximized by varying the mode of operation, where applicable.

PAGE NO. 8 of 15.

NAME OF TEST: Radiated Spurious Emissions (Continued)

MEASUREMENT DISTANCE, Meter = 3
 HEIGHT ABOVE GROUND, Meters = 0.8
 SPECTRUM SEARCHED = Per 47 CFR 15.33
 RESOLUTION BANDWIDTH, kHz = 120
 WORST CASE = VERTICAL
 SYSTEM SENSITIVITY, dBm = -130
 SEARCH ANTENNAS = See Test Setup
 POST DETECTOR VIDEO FILTERS USED = INDICATED BY "Q.P."

ALL MEASUREMENTS WERE PERFORMED MANUALLY USING:

- a. HP 85685A, option K40, (EMCO #1061) turntable with HPIB controls.
- b. HP 85685A, option K42, (EMCO #1053) antenna positioning tower with pneumatic and HPIB controls.

SAMPLE CALCULATION:

$$\begin{aligned} \text{EMISSION FREQUENCY, MHz} &= 32.300000 \\ \text{LEVEL} &= \text{Log}_{10}^{-1} \left(\frac{-7.72 + 14.56}{20} \right) \\ \text{LEVEL, } \mu\text{V/m @ 3m} &= 13 \end{aligned}$$

TEST SETUP: ATTACHED

PHOTOGRAPHS: ATTACHED

RESULTS: ATTACHED



SUPERVISED BY:

Morton Flom, P. Eng.

PAGE NO.

9 of 15.

NAME OF TEST: Radiated Spurious Emissions (Continued)

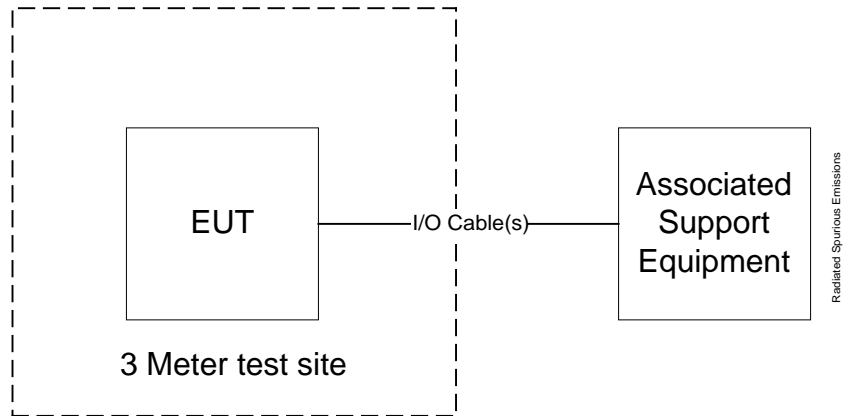

NOTES:

1. The Equipment Under Test (EUT) was located 3 meters from the search antenna and placed on a conductive ground plane.
2. The Associated Support Equipment and I/O Cable(s), if used, were placed a minimum of 30 meters from the EUT and measuring antenna.

RADIATED TEST SETUP

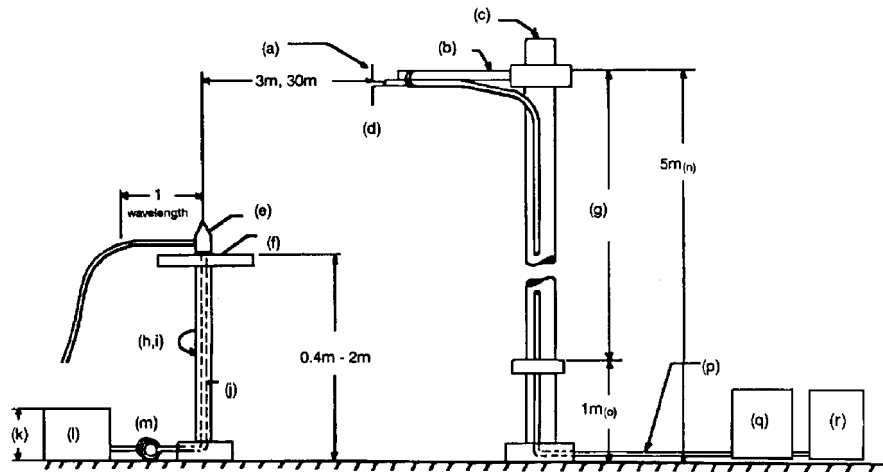

NOTES:

- (a) Search Antenna - Rotatable on boom
- (b) Non-metallic boom
- (c) Non-metallic mast
- (d) Adjustable horizontally
- (e) Equipment Under Test
- (f) Turntable
- (g) Boom adjustable in height.
- (h) External control cables routed horizontally at least one wavelength.
- (i) Rotatable
- (j) Cables routed through hollow turntable center
- (k) 30 cm or less
- (l) External power source
- (m) 10 cm diameter coil of excess cable
- (n) 25 cm (V), 1 m-7 m (V, H)
- (o) 25 cm from bottom end of 'V', 1m normally
- (p) Calibrated Cable at least 10m in length
- (q) Amplifier (optional)
- (r) Spectrum Analyzer

Asset Description (as applicable)	s/n	Cycle	Last Cal
--------------------------------------	-----	-------	----------

Per ANSI C63.4-1992, 10.1.4

TRANSDUCER

i00088	EMCO 3109-B 25MHz-300MHz	2336	12 mo.	Sep-99
i00089	Aprel 2001 200MHz-1GHz	001500	12 mo.	Sep-99
i00103	EMCO 3115 1GHz-18GHz	9208-3925	12 mo.	Sep-99
i00065	EMCO 3301-B Active Monopole	2635	12 mo.	Sep-99

AMPLIFIER

i00028	HP 8449A	2749A00121	12 mo.	Mar-00
--------	----------	------------	--------	--------

SPECTRUM ANALYZER

i00029	HP 8563E	3213A00104	12 mo.	Aug-00
i00033	HP 85462A	3625A00357	12 mo.	May-00
i00048	HP 8566B	2511AD1467	6 mo.	May-00

PAGE NO.

11 of 15.

All other emissions in the required measurement range were more than 20 dB below the required limits.

NAME OF TEST: Radiated Spurious Emissions

g0080502: 2000-Aug-02 Wed 15:40:00

STATE: 0:General

FREQUENCY EMISSION, MHz	LEVEL, @ m dBuV		C.F., dB	$\mu\text{V}/\text{m}$ @ m		Margin, dB
32.300000	7.72	3	14.56	13	3	-17.7
35.000000	1.49	3	14.2	6.09	3	-24.3
39.330000	9.35	3	13.68	14.17	3	-17
42.950000	14.69	3	13.06	24.41	3	-12.3
46.530000	19.06	3	12.45	37.63	3	-8.5
49.030000	8.87	3	12.05	11.12	3	-19.1
50.830000	4.4	3	11.76	6.43	3	-23.8
53.680000	19.72	3	11.28	35.48	3	-9
56.250000	11.66	3	10.87	13.38	3	-17.5
59.680000	8.68	3	10.35	8.94	3	-21
60.300000	9.91	3	10.26	10.2	3	-19.8
67.250000	19.68	3	9.56	28.97	3	-10.8
69.800000	10.21	3	9.32	9.47	3	-20.5
72.110000	30.76	3	9.17	99.2	3	-0.1
75.900000	10.92	3	8.94	9.84	3	-20.1
79.760000	14.96	3	8.71	15.26	3	-16.3
80.830000	26.24	3	8.8	56.49	3	-5
85.900000	13.39	3	9.37	13.74	3	-17.2
88.750000	26.57	3	9.67	64.86	3	-6.8
89.780000	11.78	3	9.78	11.97	3	-21.4
109.770000	6.48	3	1.47	2.5	3	-35.1
111.890000	8.69	3	1.5	3.23	3	-32.8
114.530000	8.44	3	1.54	3.16	3	-33
118.900000	5.89	3	1.61	2.37	3	-35.5
121.730000	4.99	3	1.65	2.15	3	-36.4
125.300000	12.09	3	1.71	4.9	3	-29.2
129.000000	4.92	3	1.77	2.16	3	-36.3
132.130000	14.13	3	14.35	26.55	3	-14.5
135.480000	16.46	3	14.61	35.77	3	-11.9
138.980000	16.37	3	14.87	36.48	3	-11.8
140.000000	16.61	3	14.95	37.84	3	-11.4
141.130000	17.71	3	14.97	43.05	3	-10.3
143.930000	21.65	3	15.01	68.08	3	-6.3
149.630000	14.9	3	15.1	31.62	3	-13
154.600000	20.61	3	15.02	60.46	3	-7.4
155.580000	21.29	3	15	65.24	3	-6.7
159.630000	18.54	3	14.93	47.15	3	-9.5
160.550000	15.48	3	14.91	33.08	3	-12.6
165.180000	18.58	3	14.83	46.83	3	-9.6
168.950000	17.41	3	14.76	40.6	3	-10.8
171.230000	15.94	3	14.76	34.28	3	-12.3
175.100000	17.16	3	14.8	39.63	3	-11
178.500000	14.93	3	14.86	30.87	3	-13.2
188.500000	16.47	3	15.79	41.02	3	-10.7

PAGE NO.

12 of 15.

NAME OF TEST: Radiated Spurious Emissions (Continued)
 g0080502: 2000-Aug-02 Wed 15:40:00
 STATE: 0:General

FREQUENCY EMISSION, MHz	LEVEL, @ m dBuV		C.F., dB	μ V/m @ m	Margin, dB
200.350000	18.93	3	17.03	62.81	3 -7
202.230000	14.22	3	17.21	37.28	3 -11.6
212.080000	14.57	3	18.1	43	3 -10.3
216.030000	17.7	3	18.46	64.27	3 -9.8
219.880000	20.45	3	18.8	91.73	3 -6.8
222.430000	14.27	3	18.99	46.03	3 -12.7
225.100000	14.64	3	19.18	49.09	3 -12.2
229.130000	16.96	3	19.46	66.22	3 -9.6
230.580000	15.08	3	19.53	53.77	3 -11.4
235.000000	21.35	3	19.66	112.33	3 -5
239.900000	24.07	3	19.81	156.31	3 -2.1
241.000000	23.36	3	19.88	145.21	3 -2.8
244.980000	23.13	3	20.16	146.05	3 -2.7
249.950000	23.8	3	20.5	164.06	3 -1.7
252.000000	22.62	3	20.52	143.55	3 -2.9
254.950000	23.11	3	20.55	152.41	3 -2.3
258.980000	21.33	3	20.6	124.88	3 -4.1
260.930000	20.12	3	20.66	109.4	3 -5.2
263.950000	19.28	3	20.81	101.04	3 -5.9
265.050000	18.27	3	20.86	90.47	3 -6.9
269.530000	16.41	3	21.09	74.99	3 -8.5
271.030000	14.82	3	21.15	62.88	3 -10
275.030000	15.57	3	21.31	69.82	3 -9.1
279.100000	15.93	3	21.47	74.13	3 -8.6
282.650000	18.38	3	21.49	98.51	3 -6.1
284.980000	15.65	3	21.46	71.7	3 -8.9
289.600000	16.1	3	21.41	75.08	3 -8.5
290.950000	16.64	3	22.31	88.61	3 -7.1
295.050000	19.37	3	26.14	188.58	3 -0.5
298.930000	15.48	3	29.72	181.97	3 -0.8
303.995000	9.97	3	18.05	25.18	3 -18
305.000000	9.76	3	18.11	24.75	3 -18.1
307.190000	13.99	3	18.25	40.93	3 -13.8
309.390000	8.05	3	18.38	20.97	3 -19.6
311.030000	8.28	3	18.48	21.78	3 -19.2
315.000000	8.59	3	18.73	23.23	3 -18.7
319.480000	15.97	3	18.99	55.98	3 -11
320.980000	7.88	3	19.08	22.28	3 -19
324.950000	6.33	3	19.32	19.16	3 -20.4
328.980000	6.74	3	19.55	20.63	3 -19.7
331.330000	7.25	3	19.68	22.21	3 -19.1
335.000000	8.62	3	19.89	26.64	3 -17.5
339.100000	10.46	3	20.12	33.81	3 -15.4
340.830000	7.68	3	20.22	24.83	3 -18.1
345.080000	9.89	3	20.45	32.89	3 -15.7
349.330000	7.53	3	20.69	25.76	3 -17.8
351.950000	13.67	3	20.83	53.09	3 -11.5

PAGE NO.

13 of 15.

NAME OF TEST: Radiated Spurious Emissions (Continued)
g0080502: 2000-Aug-02 Wed 15:40:00
STATE: 0:General

FREQUENCY EMISSION, MHz	LEVEL, @ m dBuV		C.F., dB	μ V/m @ m	Margin, dB
355.000000	12.1	3	21	45.19	3 -12.9
358.680000	12.38	3	21.21	47.81	3 -12.4
365.000000	14.67	3	21.56	64.79	3 -9.8
368.680000	17.43	3	21.77	91.2	3 -6.8
375.000000	14.56	3	22.11	68.16	3 -9.3
377.900000	10.14	3	22.26	41.69	3 -13.6
384.455000	9.14	3	22.6	38.64	3 -14.3
389.187000	7.51	3	22.85	32.96	3 -15.6
393.200000	16.63	3	23.06	96.49	3 -6.3
396.230000	9.95	3	23.22	45.55	3 -12.8
405.480000	12.72	3	23.39	63.9	3 -9.9
409.000000	6.74	3	23.38	32.06	3 -15.9
414.000000	5.97	3	23.37	29.31	3 -16.7
417.800000	15.5	3	23.35	87.6	3 -7.2
422.980000	7.81	3	23.34	36.1	3 -14.9
427.980000	6.52	3	23.33	31.08	3 -16.2
430.200000	15.19	3	23.33	84.33	3 -7.5
435.030000	8	3	23.31	36.77	3 -14.7
439.000000	7.91	3	23.31	36.39	3 -14.8
442.380000	15.99	3	23.3	92.15	3 -6.7
447.000000	12.15	3	23.28	59.09	3 -10.6
451.200000	9.46	3	23.28	43.35	3 -13.3
457.900000	7.98	3	23.29	36.6	3 -14.7
460.850000	8.39	3	23.28	38.33	3 -14.3
466.980000	15.74	3	23.29	89.43	3 -7
470.050000	3.88	3	23.29	22.83	3 -18.8
475.030000	3.9	3	23.29	22.88	3 -18.8
479.080000	7.52	3	23.29	34.71	3 -15.2
482.300000	4.26	3	23.29	23.85	3 -18.5
487.550000	4.64	3	23.29	24.92	3 -18.1
494.600000	5.22	3	23.3	26.67	3 -17.5
498.230000	5.48	3	23.3	27.48	3 -17.2
505.000000	7.11	3	23.5	33.92	3 -15.4
509.030000	3.33	3	23.67	22.39	3 -19
511.700000	5.49	3	23.77	29.04	3 -16.7
515.050000	4.95	3	23.9	27.7	3 -17.2
518.900000	2.55	3	24.05	21.38	3 -19.4
522.080000	2.42	3	24.18	21.38	3 -19.4
525.100000	4.05	3	24.3	26.15	3 -17.7
529.680000	2.93	3	24.47	23.44	3 -18.6
532.080000	3.27	3	24.56	24.63	3 -18.2
537.280000	16.1	3	24.76	110.41	3 -5.1
541.200000	3.36	3	24.91	25.91	3 -17.7
550.500000	3.07	3	25.25	26.06	3 -17.7
553.600000	4.31	3	25.37	30.48	3 -16.3
557.800000	3.59	3	25.52	28.54	3 -16.9
561.580000	3.7	3	25.66	29.38	3 -16.6

PAGE NO.

14 of 15.

NAME OF TEST: Radiated Spurious Emissions (Continued)
 g0080502: 2000-Aug-02 Wed 15:40:00
 STATE: 0:General

FREQUENCY EMISSION, MHz	LEVEL, @ m dBuV		C.F., dB	μ V/m @ m	Margin, dB
565.230000	3.92	3	25.79	30.58	3 -16.3
569.630000	2.16	3	25.94	25.41	3 -17.9
571.530000	2.42	3	26.02	26.42	3 -17.6
578.230000	1.85	3	26.25	25.41	3 -17.9
582.150000	2.73	3	26.39	28.58	3 -16.9
587.180000	3.64	3	26.57	32.4	3 -15.8
590.250000	4.61	3	26.67	36.64	3 -14.7
591.850000	2.2	3	26.72	27.93	3 -17.1
595.980000	3	3	26.86	31.12	3 -16.1
600.000000	6.21	3	27	45.76	3 -12.8
608.430000	6.55	3	27.11	48.19	3 -12.3
611.980000	4.26	3	27.15	37.2	3 -14.6
615.000000	2.69	3	27.19	31.19	3 -16.1
617.000000	1.89	3	27.22	28.54	3 -16.9
627.000000	4.37	3	27.34	38.5	3 -14.3
637.000000	4.75	3	27.46	40.78	3 -13.8
647.000000	4.21	3	27.59	38.9	3 -14.2
655.900000	3.44	3	27.7	36.06	3 -14.9
665.900000	5.11	3	27.81	44.26	3 -13.1
675.900000	3.69	3	27.93	38.11	3 -14.4
685.900000	5.34	3	28.04	46.67	3 -12.6
698.630000	10.43	3	28.18	85.21	3 -7.4
706.980000	3.69	3	28.3	39.76	3 -14
716.980000	1.28	3	28.44	30.62	3 -16.3
728.330000	3.26	3	28.59	39.13	3 -14.2
737.000000	1.78	3	28.7	33.42	3 -15.5
747.000000	3.26	3	28.83	40.23	3 -13.9
759.000000	3.06	3	28.98	39.99	3 -14
769.000000	3.26	3	29.11	41.54	3 -13.6
779.000000	2.72	3	29.24	39.63	3 -14
789.000000	3.94	3	29.37	46.29	3 -12.7
799.000000	3.61	3	29.48	45.13	3 -12.9
809.000000	2.59	3	29.53	40.36	3 -13.9
819.000000	5.65	3	29.56	57.61	3 -10.8
829.000000	4.25	3	29.59	49.2	3 -12.2
839.000000	4.92	3	29.62	53.33	3 -11.5
849.000000	3.87	3	29.64	47.37	3 -12.5
859.700000	5.24	3	29.68	55.72	3 -11.1
869.700000	5.8	3	29.7	59.57	3 -10.5
879.780000	4.71	3	29.73	52.72	3 -11.6
889.750000	4.92	3	29.75	54.14	3 -11.3
899.750000	6.52	3	29.78	65.31	3 -9.7
909.750000	4.88	3	30.71	60.19	3 -10.4
919.750000	4.74	3	31.67	66.15	3 -9.6
928.530000	4.35	3	32.48	69.42	3 -9.2
938.530000	6.24	3	33.42	96.16	3 -6.3
948.530000	4.36	3	34.34	86.1	3 -7.3

PAGE NO.

15 of 15.

NAME OF TEST: Radiated Spurious Emissions (Continued)

g0080502: 2000-Aug-02 Wed 15:40:00

STATE: 0:General

FREQUENCY EMISSION, MHz	LEVEL, @ m dBuV		C.F., dB	μ V/m @ m	Margin, dB
958.530000	3.82	3	35.25	89.85	3 -6.9
968.530000	4.03	3	36.15	102.09	3 -13.8
978.530000	4.97	3	37.04	126.04	3 -12
988.530000	3.85	3	37.92	122.6	3 -12.2
998.530000	7.72	3	38.77	211.11	3 -7.5
1000.000000	8.51	3	38.9	234.69	3 -6.6

SUPERVISED BY:

Morton Flom, P. Eng.

LABELING REQUIREMENTS
(For Certification, and Verification)

47 CFR 15.19 Labeling requirements.

(a) In addition to the requirements in Part 2 of this chapter, a device subject to certification, or verification shall be labeled as follows:

(1) Receivers associated with the operation of a licensed radio service, e.g., FM broadcast under part 73 of this chapter, land mobile operation under part 90, etc., shall bear the following statement in a conspicuous location on the device:

This device complies with part 15 of the FCC Rules. Operation is subject to the condition that this device does not cause harmful interference.

(2) A stand-alone cable input selector switch shall bear the following statement in a conspicuous location on the device:

This device is verified to comply with part 15 of the FCC Rules for use with cable television service.

(3) All other devices shall bear the following statement in a conspicuous location on the device:

This device complies with part 15 of the FCC Rules. Operation is subject to the following two conditions: (1) This device may not cause harmful interference, and (2) this device must accept any interference received, including interference that may cause undesired operation.

(b) Where a device is constructed in two or more sections connected by wires and marketed together, the statement specified in this section is required to be affixed to the main control unit.

(c) When the device is so small or for such use that it is not practicable to place the statement specified in this section on it, the information required by these paragraphs shall be placed in a prominent location in the instruction manual or pamphlet supplied to the user or, alternatively, shall be placed on the container in which the device is marketed. However, the FCC identifier or the unique identifier, as appropriate, must be displayed on the device.

COMPLIANCE STATEMENT

15.105(b) INFORMATION TO THE USER
(For Class B equipment only)

For a Class B digital device or peripheral, the instructions furnished the user shall include the following or similar statement, placed in a prominent location in the text of the manual:

NOTE: This equipment has been tested and found to comply with the limits of Part 15 of the FCC Rules. These limits are designed to provide reasonable protection against harmful interference in a residential installation. This equipment generates, uses and can radiate radio frequency energy and, if not installed and used in accordance with the instructions, may cause harmful interference to radio communications. However, there is no guarantee that interference will not occur in a particular installation. If this equipment does cause harmful interference to radio or television reception, which can be determined by turning the equipment off and on, the user is encouraged to try to correct the interference by one or more of the following measures:

- Reorient or relocate the receiving antenna.
- Increase the separation between the equipment and receiver.
- Connect the equipment into an outlet on a circuit different from that to which the receiver is connected.
- Consult the dealer or an experienced radio/TV technician for help.

THE APPLICANT HAS BEEN CAUTIONED AS TO THE FOLLOWING:

15.21 INFORMATION TO USER.

The users manual or instruction manual for an intentional radiator shall caution the user that changes or modifications not expressly approved by the party responsible for compliance could void the user's authority to operate the equipment.

15.27(a) SPECIAL ACCESSORIES.

Equipment marketed to a consumer must be capable of complying with the necessary regulations in the configuration in which the equipment is marketed. Where special accessories, such as shielded cables and/or special connectors are required to enable an unintentional or intentional radiator to comply with the emission limits in this part, the equipment must be marketed with, i.e. shipped and sold with, those special accessories. However, in lieu of shipping or packaging the special accessories with the unintentional or intentional radiator, the responsible party may employ other methods of ensuring that the special accessories are provided to the consumer, without additional charge.

Information detailing any alternative method used to supply the special accessories for a grant of equipment authorization or retained in the verification records, as appropriate. The party responsible for the equipment, as detailed in § 2.909 of this chapter, shall ensure that these special accessories are provided with the equipment. The instruction manual for such devices shall include appropriate instructions on the first page of text concerned with the installation of the device that these special accessories must be used with the device. It is the responsibility of the user to use the needed special accessories supplied with the equipment.

47 CFR 15.107(a): A/C Powerline Conducted Emission Limits15.107(a) CLASS B CONDUCTED LIMITS

Frequency of Emission, MHz	μV	dBuV
0.450 - 30	250	48

15.107(b) CLASS A CONDUCTED LIMITS

Frequency of Emission, MHz	μV	dBuV
0.450 - 1.705	1000	60
1.705 - 30.0	3000	70

47 CFR 15.109(a): Radiated Emission Limits15.109(a) CLASS B RADIATED LIMITS

Frequency of Emission, MHz	Field Strength, $\mu\text{V}/\text{m}$ @ 3m
30 - 88	100
88 - 216	150
216 - 960	200
Above 960	500

15.109(b) CLASS A RADIATED LIMITS

Frequency of Emission, MHz	Field Strength, $\mu\text{V}/\text{m}$ @ 10m	Field Strength, $\mu\text{V}/\text{m}$ @ 3m
30 - 88	90	284
88 - 216	150	474
216 - 960	210	664
Above 960	300	949

47 CFR 15.111: Receiver Antenna Conducted Emission Limits

The power at the antenna terminal at any frequency within the range of measurements shall not exceed 2.0 nanowatts.

STATEMENT OF COMPLIANCE

THIS IS TO CERTIFY:

THAT, ON THE BASIS OF THE MEASUREMENTS MADE, THE
EQUIPMENT TESTED IS CAPABLE OF COMPLYING WITH THE
REQUIREMENTS OF

FCC RULE PART 15, SUBPART B x

FCC RULE PART 15, SUBPART C

USING ANSI C63.4-1992 IN EFFECT AS OF THIS DATE, UNDER
NORMAL OPERATION, WITH THE USUAL MAINTENANCE.

THAT THE DATA CONTAINED HEREIN IS A SUMMARY (WORST CASE)
OF THAT OBTAINED ON SEVERAL RANDOMLY-SELECTED PRODUCTION
SAMPLES.

THAT THE EQUIPMENT MEETS OR EXCEEDS THE REQUIREMENTS OF
PART 15.

SUPERVISED BY:

Morton Flom, P. Eng.

LIST OF EXHIBITS
(FCC **VERIFICATION** - REVISED 3/24/97)

APPLICANT:

EQUIPMENT:

BY APPLICANT:

IF APPLICABLE: Subsection 2.1033

1. LETTER OF AUTHORIZATION
2. IDENTIFICATION LABEL DRAWING
 - ___ LABEL
 - ___ LOCATION OF LABEL
 - ___ COMPLIANCE STATEMENT
 - ___ LOCATION OF COMPLIANCE STATEMENT
3. DOCUMENTATION: 2.1033(b)
 - (3) USER MANUAL
 - (4) OPERATIONAL DESCRIPTION
 - (5) BLOCK DIAGRAM
 - (5) SCHEMATIC DIAGRAM
 - (7) PHOTOGRAPHS

BY M.F.A. INC.

- A. STATEMENT OF COMPLIANCE
- B. STATEMENT OF QUALIFICATIONS
- C. LIST OF TEST INSTRUMENTATION