

8 7 6 5 4 3 2 1

--REVISION--				
REV	DESCRIPTION	ECN	APPROVE	
			MECH	MFG
A0	INITIAL RELEASE	6057	JAM	

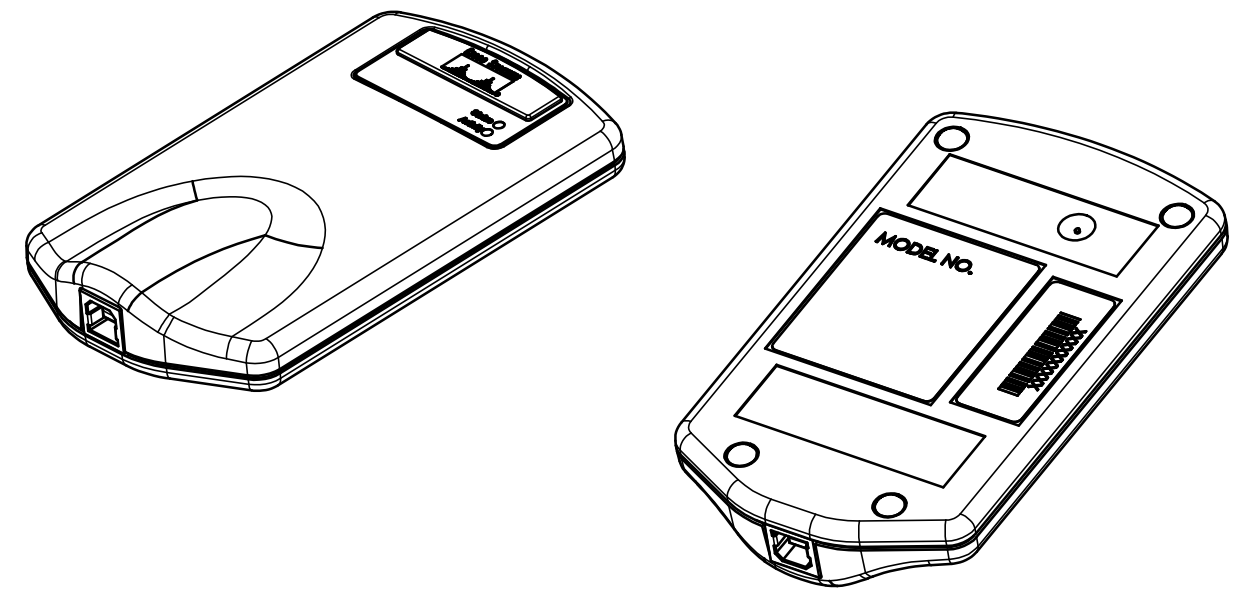
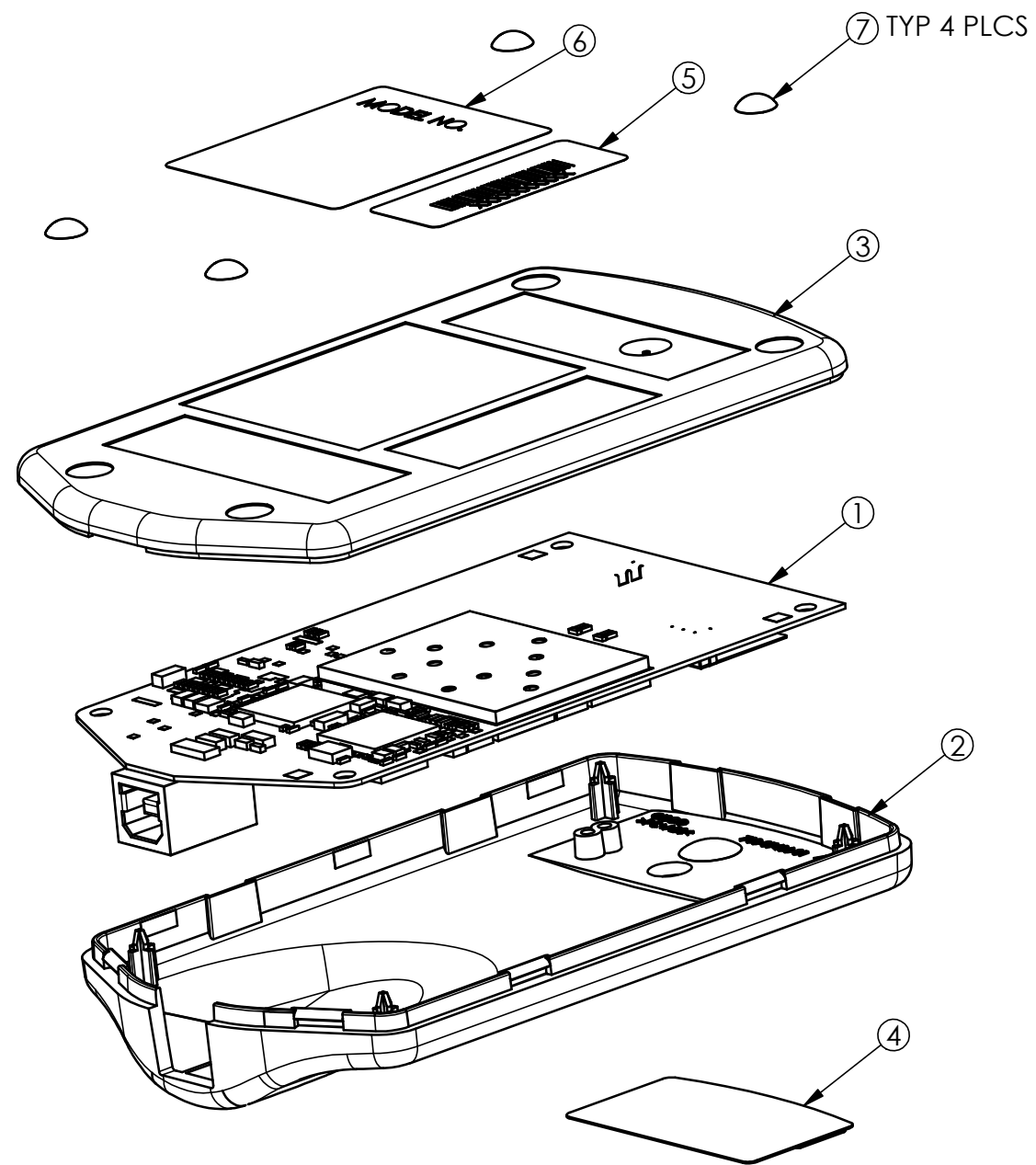

NOTES: UNLESS OTHERWISE SPECIFIED
 1) REFERENCE BOM'S xxxxxxxxxxxxxxxxxxxxxxx .
 2) SHALL MEET MECHANICAL ACCEPTANCE SPEC., DOCUMENT NO. 5-0669-XX .
 3) PLACE SERIAL LABEL APPROX. AS SHOWN. REFER TO CISCO SPECIFICATION FOR LABEL AND PRINTING REQUIREMENT, DOCUMENT NO. 701806-0000.

ASSEMBLY PROCEDURE:
 1) MOUNT ITEM 1 HOLES INTO ITEM 2 LOCATING PINS, ORIENTED AS SHOWN
 2) SNAP ITEM 3 TO ITEM 2
 3) ASSEMBLE ITEM 4 TO ITEM 2, ORIENTED AS SHOWN
 4) ASSEMBLE ITEMS 5 & 6 TO ITEM 3, ORIENTED AS SHOWN
 5) ASSEMBLE ITEM 7 (QTY 4) TO ITEM 3

UNLESS OTHERWISE SPECIFIED DIMENSIONS ARE IN INCHES: TOLERANCES: X.X = ±.030 X.XX = ±.015 X.XXX = ±.005 ANGULAR = ±0°-30'	THIS DRAWING CONTAINS INFORMATION WHICH IS THE PROPRIETARY PROPERTY OF CISCO SYSTEMS. THIS DRAWING IS CONFIDENTIAL AND ITS CONTENTS MAY NOT BE DISCLOSED WITHOUT PRIOR WRITTEN CONSENT OF CISCO SYSTEMS.			
	APPROVAL		DATE	
MATERIAL:	DES:	SIZE	DWG NO.	REV
FINISH:	ENG: JAM	B	62-6387-01	A0
DO NOT SCALE DRAWING		SCALE: 1:1	MODEL FILE: 62-6387-01	SHT 1 OF 1

8 7 6 5 4 3 2 1

CAD TYPE: SOLIDWORKS