

802.11n-HT20 Power Spectral Density - Ant 1 / Ant 0 + 1

Channel 36 (5180MHz)

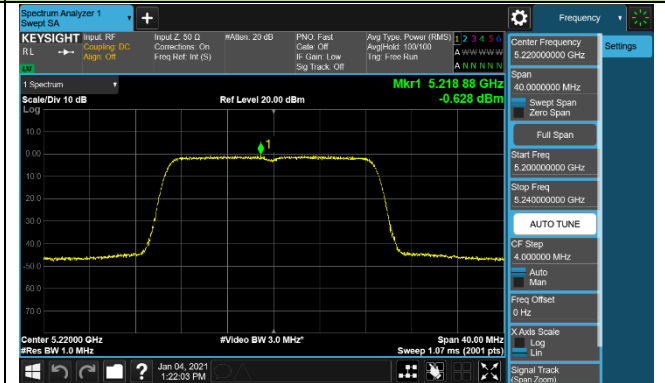

Channel 44 (5220MHz)



Channel 48 (5240MHz)

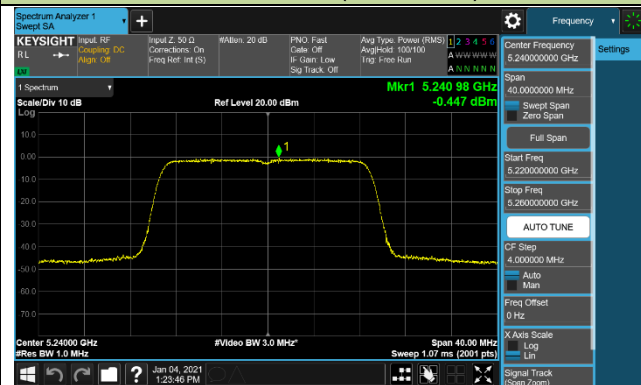

Channel 52 (5260MHz)

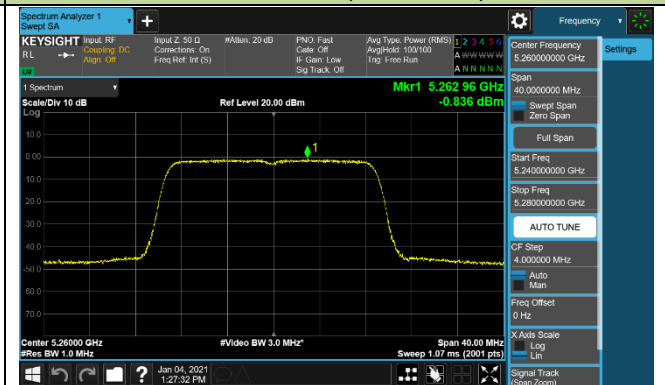

Channel 60 (5300MHz)

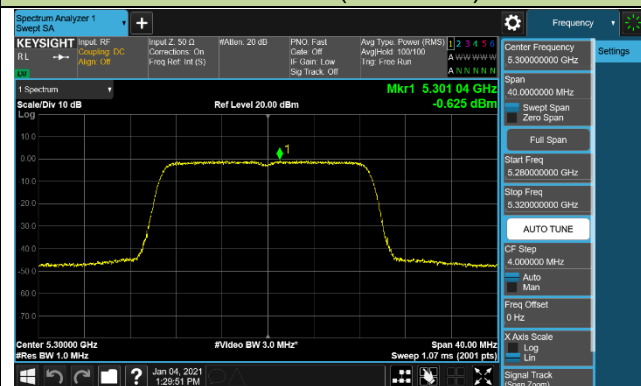

Channel 64 (5320MHz)

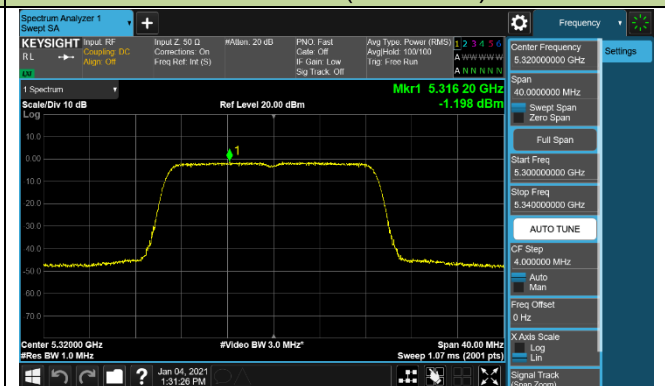

Channel 100 (5500MHz)

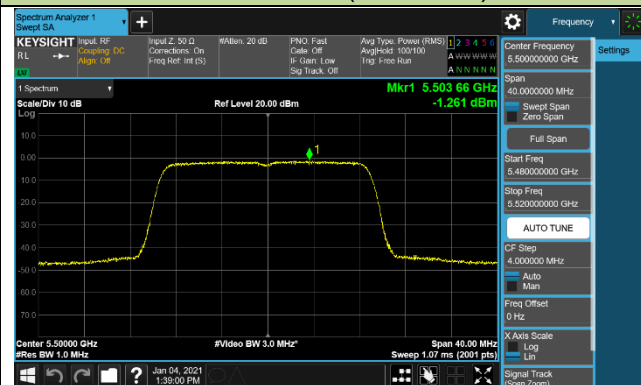

Channel 116 (5580MHz)

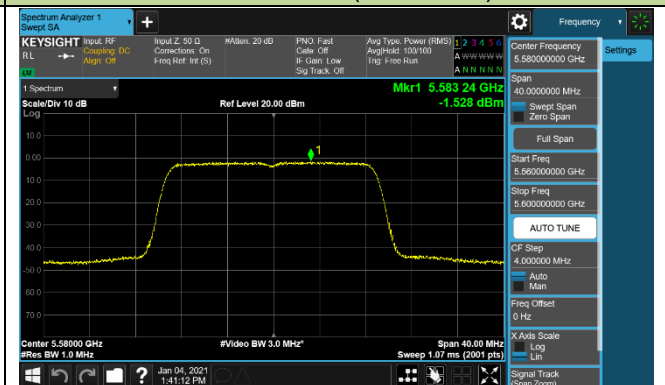

802.11n-HT20 Power Spectral Density - Ant 1 / Ant 0 + 1

Channel 140 (5700MHz)

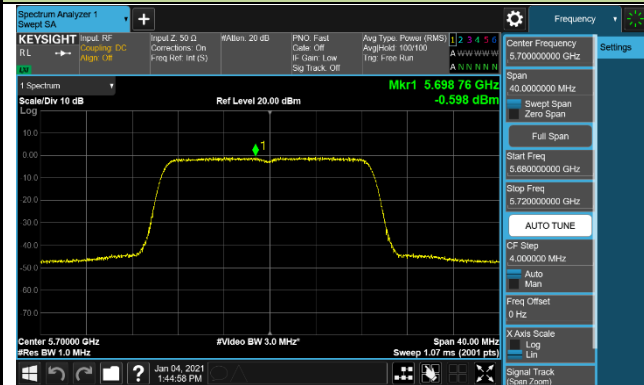

Channel 144 (5720MHz)

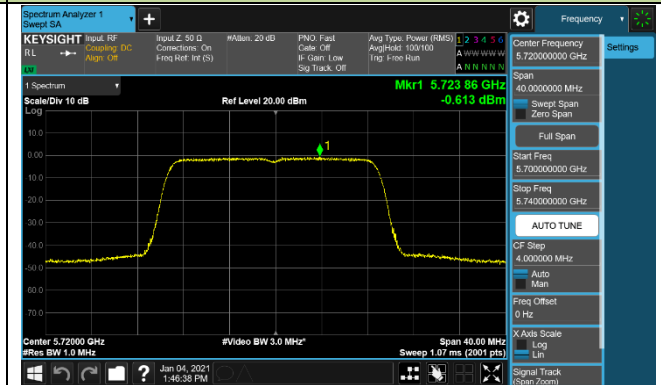

Channel 149 (5745MHz)

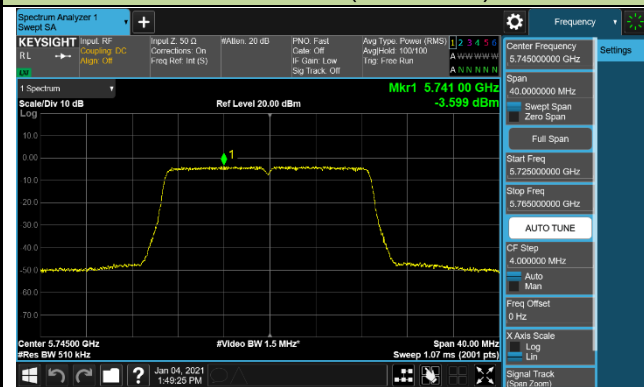

Channel 157 (5785MHz)

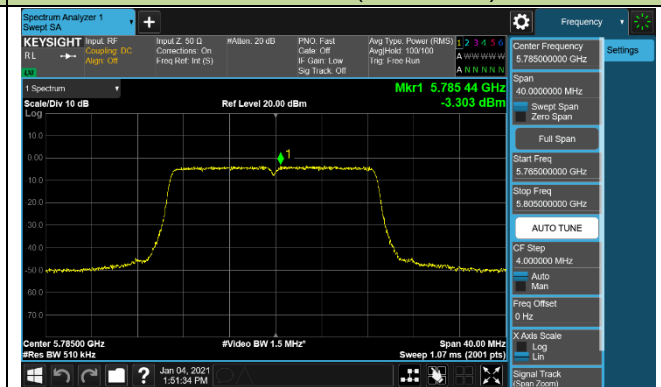

Channel 165 (5825MHz)

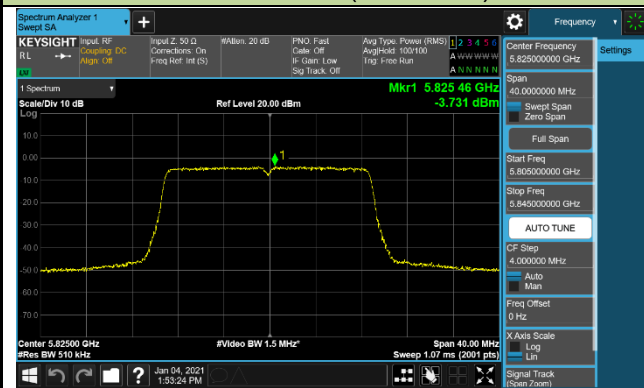

802.11n-HT40 Power Spectral Density - Ant 1 / Ant 0 + 1

Channel 38 (5190MHz)

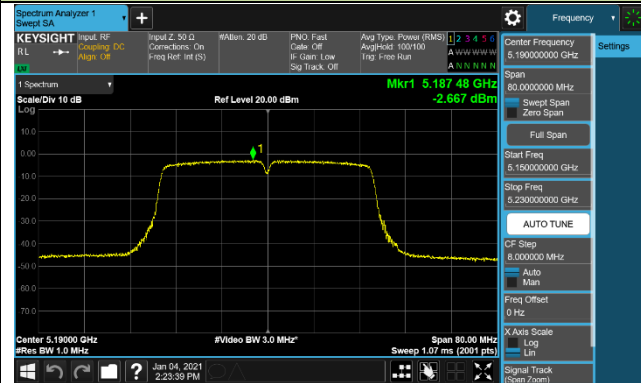

Channel 46 (5230MHz)

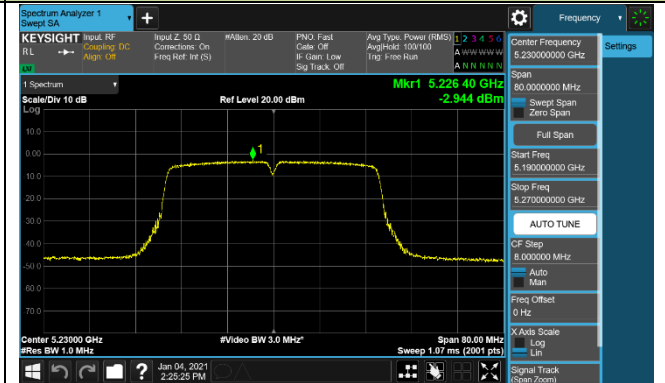

Channel 54 (5270MHz)

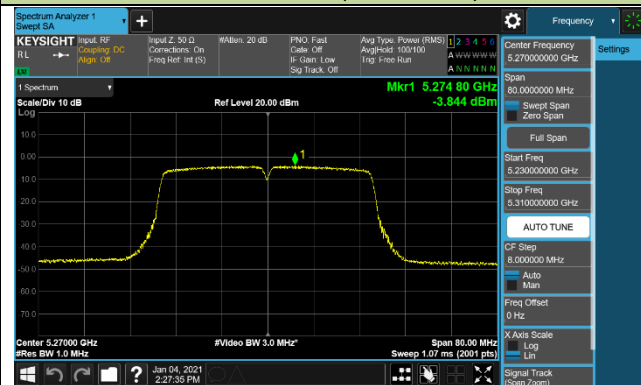

Channel 62 (5310MHz)

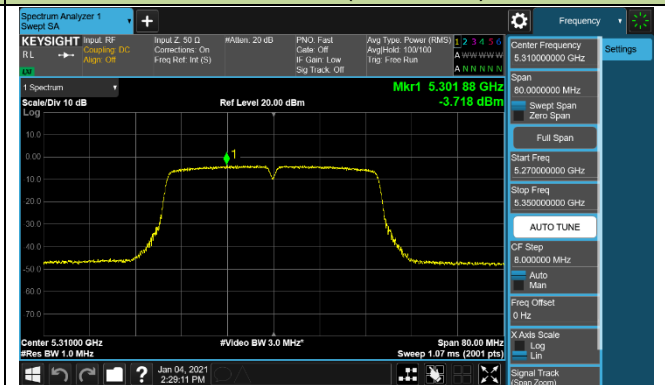

Channel 102 (5510MHz)

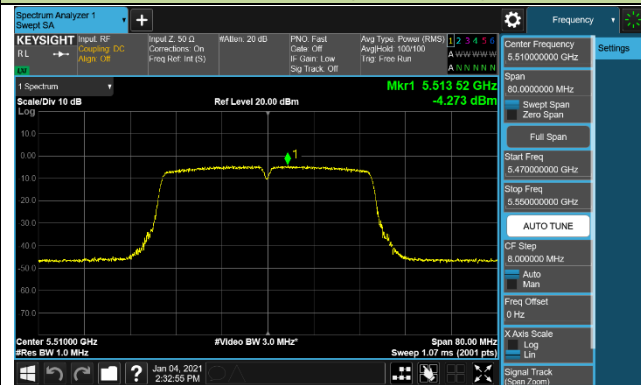

Channel 110 (5550MHz)

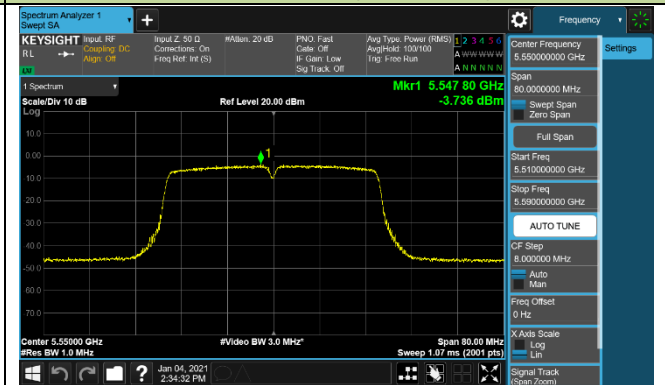

Channel 134 (5670MHz)

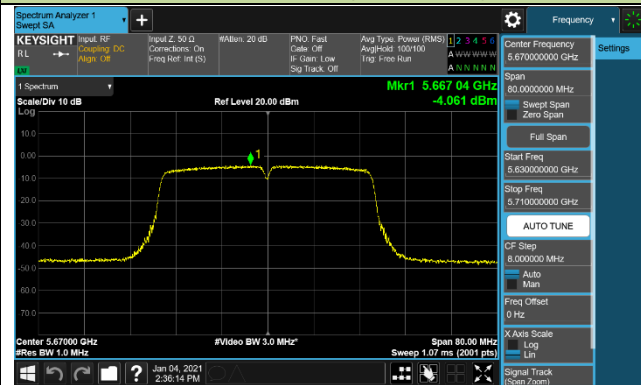

Channel 142 (5710MHz)

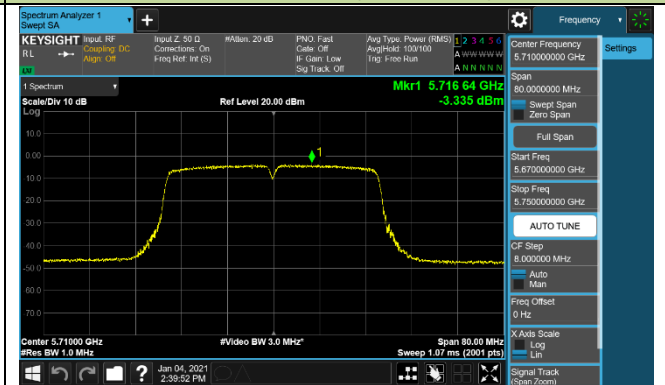

802.11n-HT40 Power Spectral Density - Ant 1 / Ant 0 + 1

Channel 151 (5755MHz)

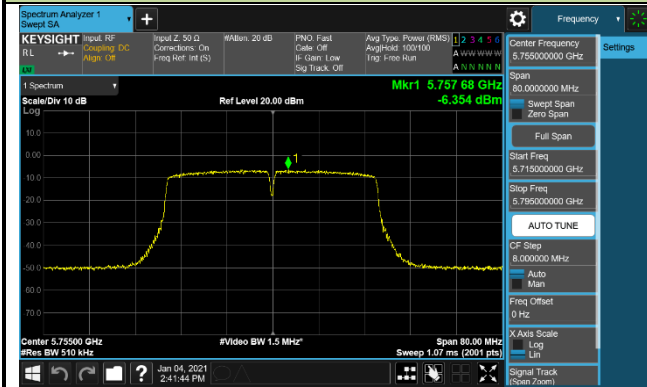

Channel 159 (5795MHz)

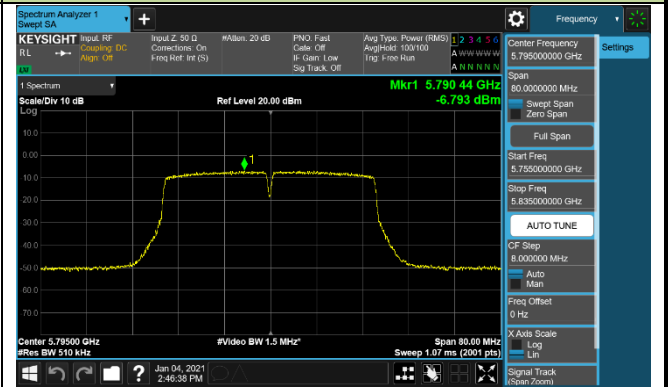

802.11ac-VHT20 Power Spectral Density - Ant 1 / Ant 0 + 1

Channel 36 (5180MHz)

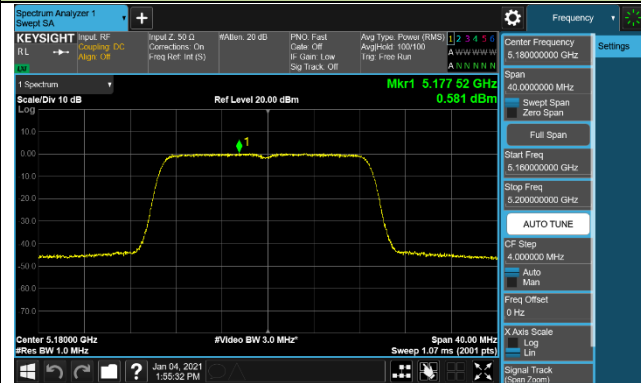

Channel 44 (5220MHz)

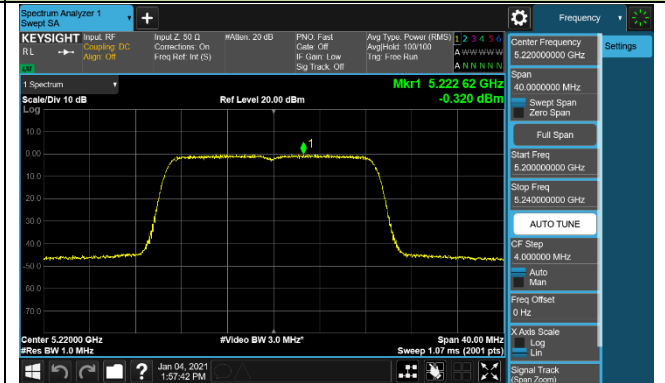

Channel 48 (5240MHz)

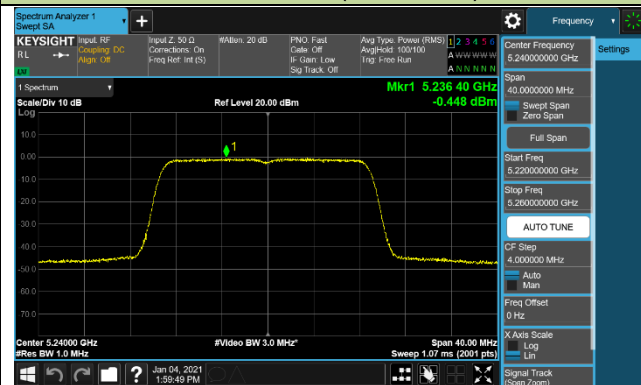

Channel 52 (5260MHz)

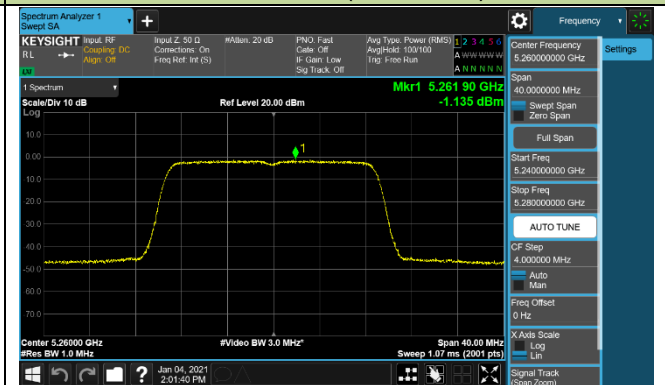

Channel 60 (5300MHz)

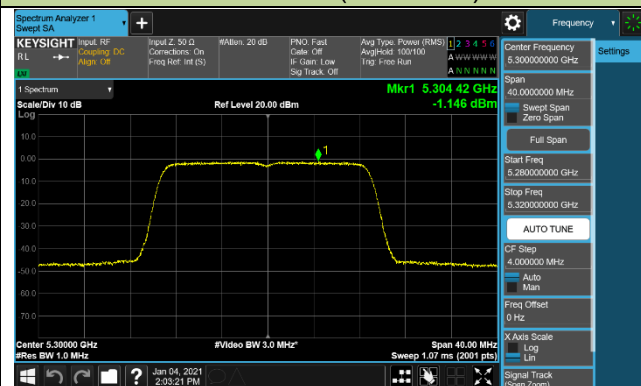

Channel 64 (5320MHz)

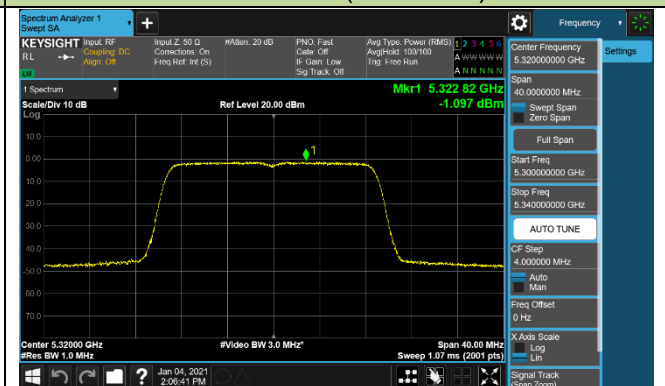

Channel 100 (5500MHz)

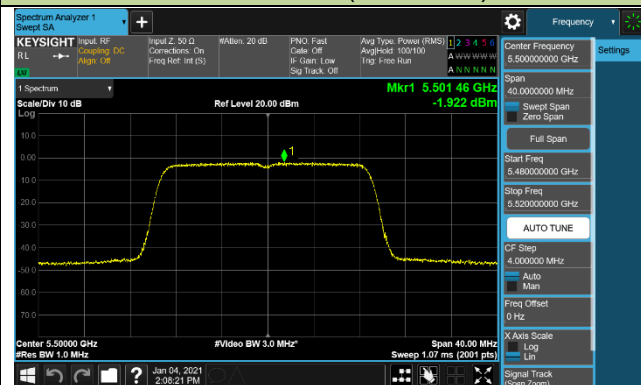

Channel 116 (5580MHz)

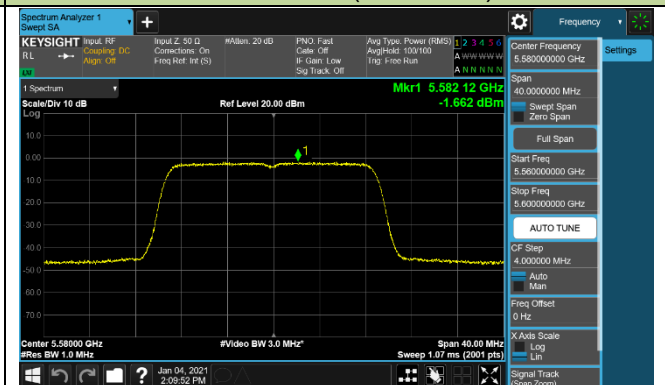

802.11ac-VHT20 Power Spectral Density - Ant 1 / Ant 0 + 1

Channel 140 (5700MHz)

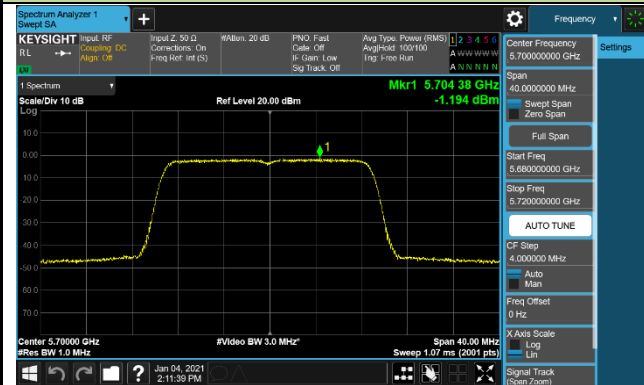

Channel 144 (5720MHz)

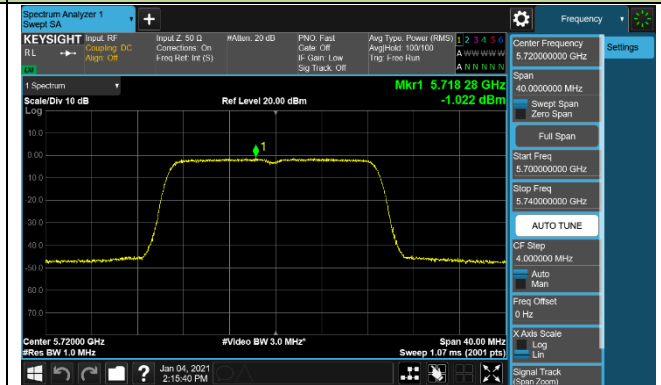

Channel 149 (5745MHz)

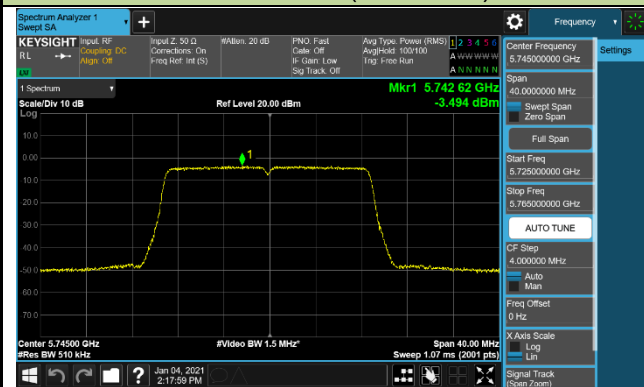

Channel 157 (5785MHz)

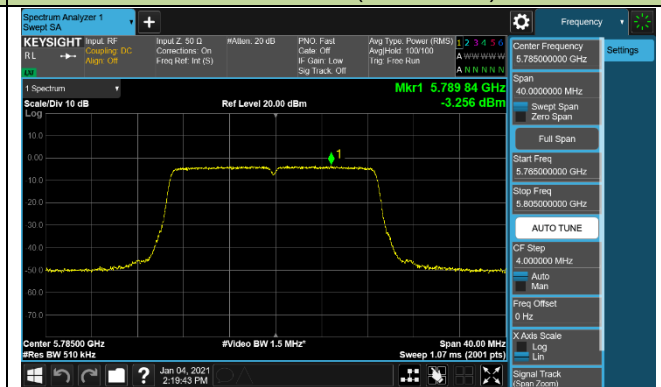

Channel 165 (5825MHz)

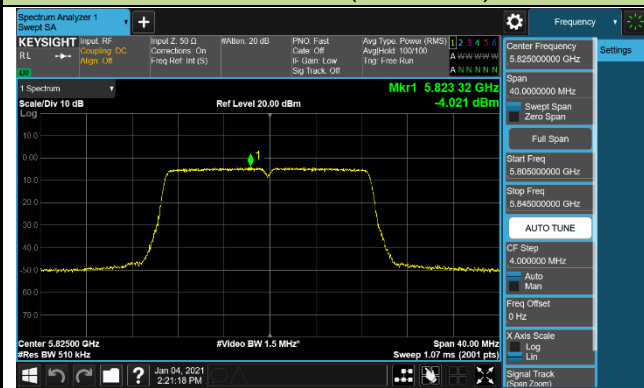

802.11ac-VHT40 Power Spectral Density - Ant 1 / Ant 0 + 1

Channel 38 (5190MHz)

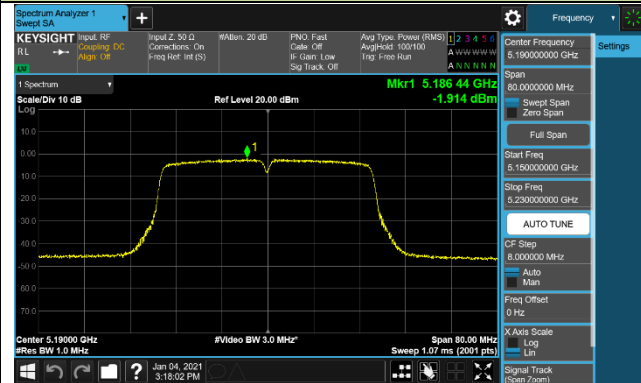

Channel 46 (5230MHz)

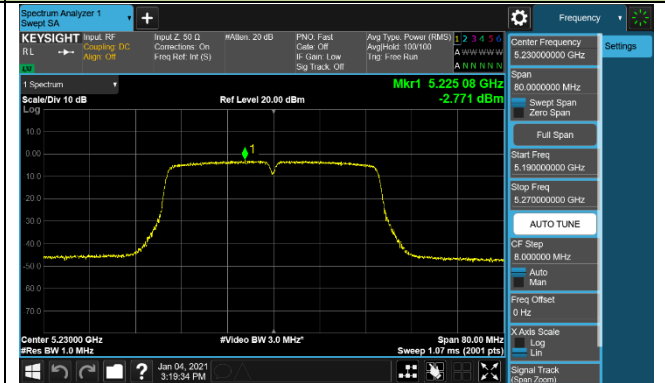

Channel 54 (5270MHz)

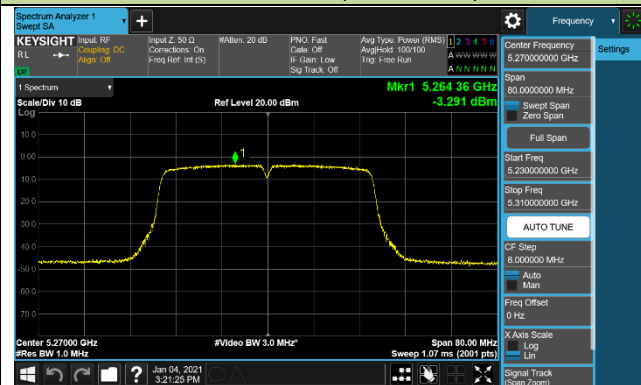

Channel 62 (5310MHz)

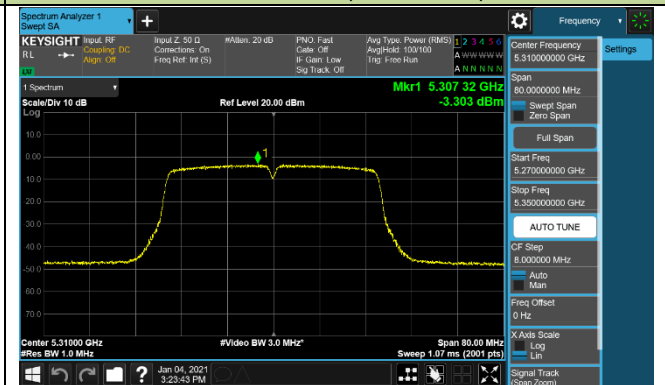

Channel 102 (5510MHz)

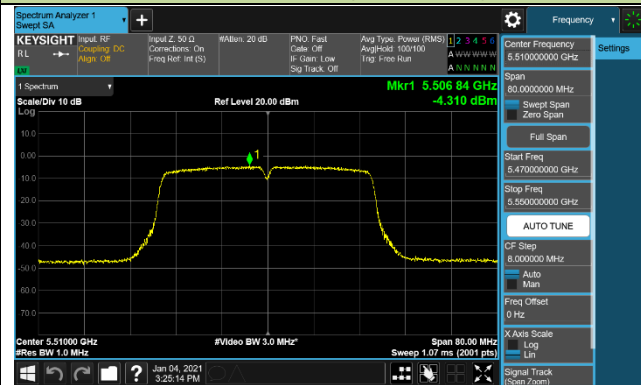

Channel 110 (5550MHz)

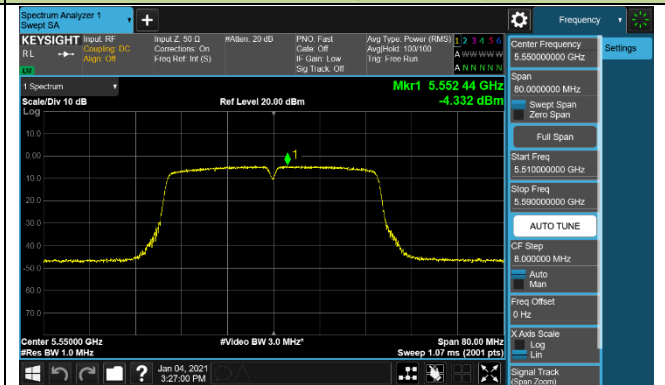

Channel 134 (5670MHz)

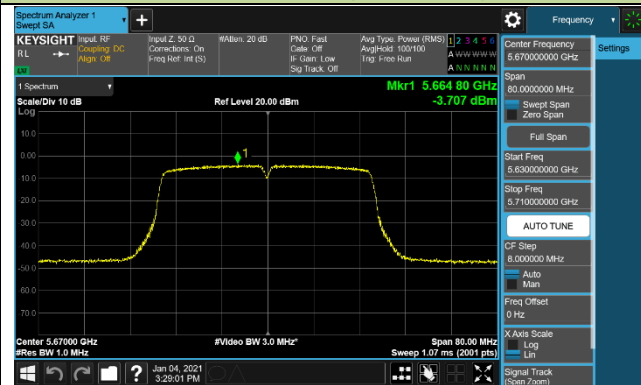

Channel 142 (5710MHz)

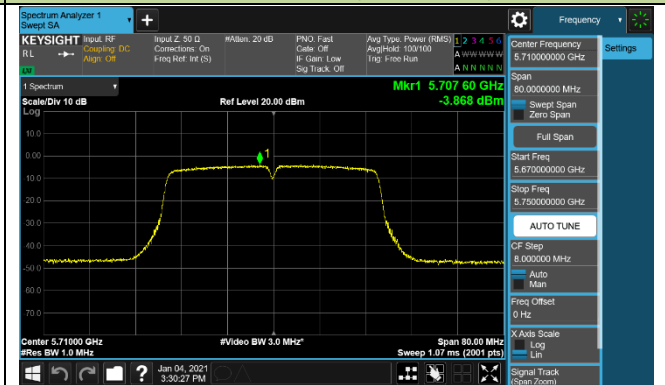

802.11ac-VHT40 Power Spectral Density - Ant 1 / Ant 0 + 1

Channel 151 (5755MHz)

Channel 159 (5795MHz)

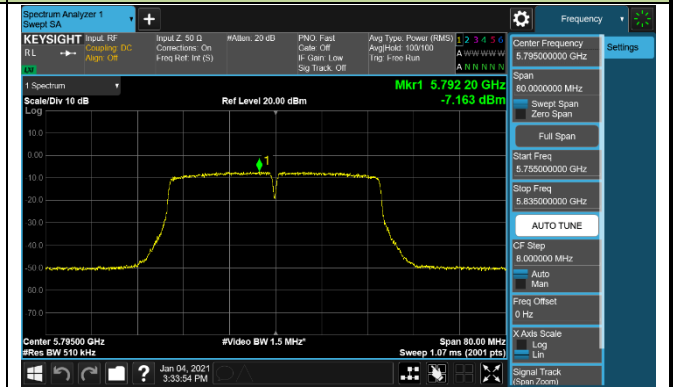
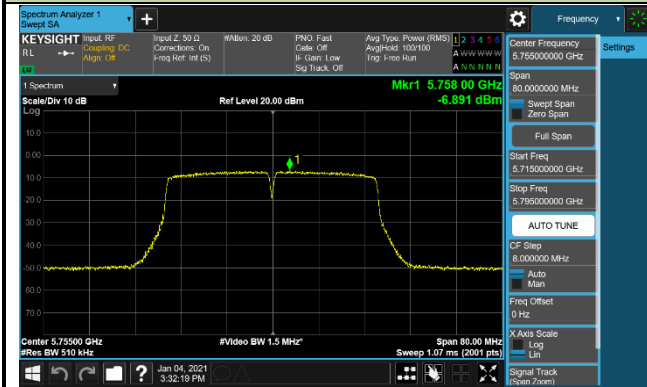

802.11ac-VHT80 Power Spectral Density - Ant 1 / Ant 0 + 1

Channel 42 (5210MHz)

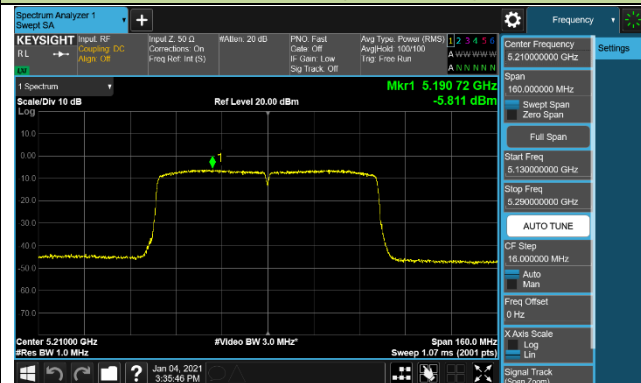

Channel 58 (5290MHz)

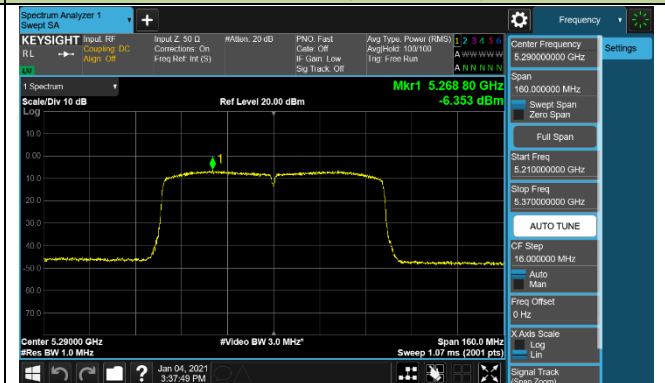

Channel 106 (5530MHz)

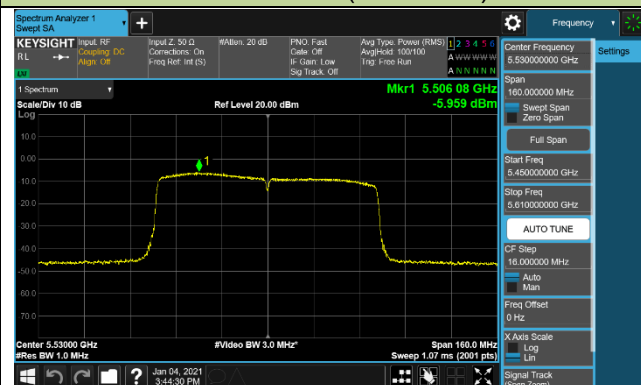

Channel 122 (5610MHz)

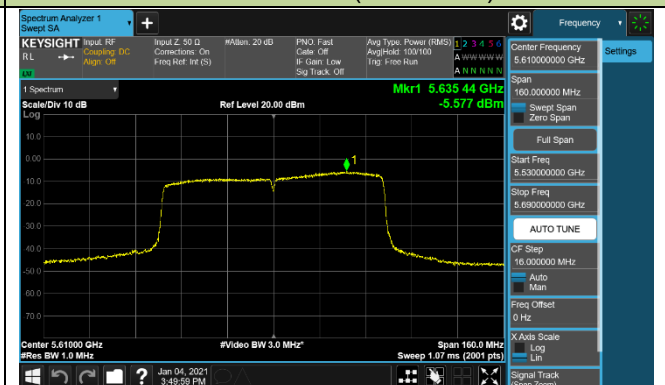

Channel 138 (5690MHz)

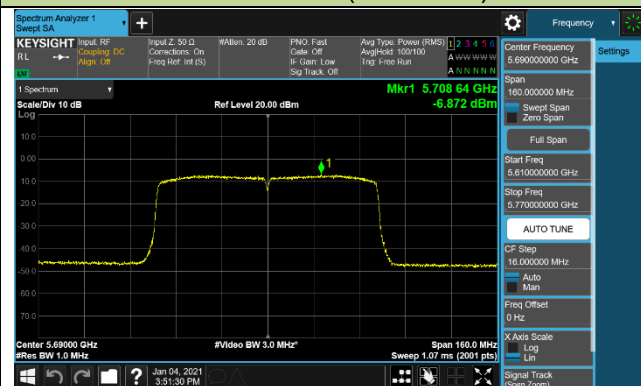

Channel 155 (5775MHz)

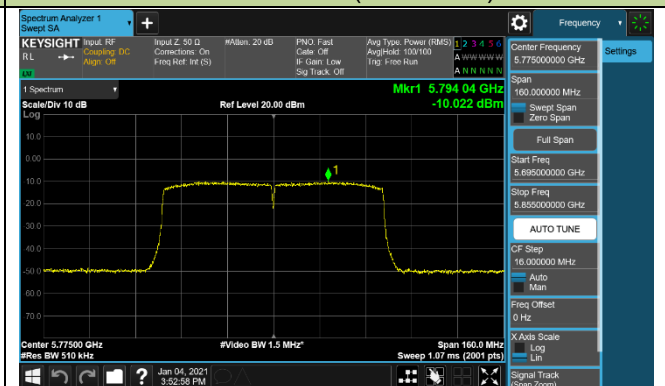

6.7. Frequency Stability Measurement

6.7.1. Test Limit

Manufactures of U-NII devices are responsible for ensuring frequency stability such that an emission is maintained within the band of operation under all conditions of normal operation as specified in the user's manual.

6.7.2. Test Procedure Used

Frequency Stability Under Temperature Variations:

The equipment under test was connected to an external AC or DC power supply and input rated voltage. RF output was connected to a frequency counter or spectrum analyzer via feed through attenuators. The EUT was placed inside the temperature chamber. Set the spectrum analyzer RBW low enough to obtain the desired frequency resolution and measure EUT 20°C operating frequency as reference frequency. Turn EUT off and set the chamber temperature to highest. After the temperature stabilized for approximately 30 minutes recorded the frequency. Repeat step measure with 10°C decreased per stage until the lowest temperature reached.

Frequency Stability Under Voltage Variations:

Set chamber temperature to 20°C. Use a variable AC power supply / DC power source to power the EUT and set the voltage to rated voltage. Set the spectrum analyzer RBW low enough to obtain the desired frequency resolution and recorded the frequency.

Reduce the input voltage to specify extreme voltage variation ($\pm 15\%$) and endpoint, record the maximum frequency change. For hand-carried battery-powered equipment, primary supply voltage is reduced to the battery operating end point which shall be specified by the manufacturer.

6.7.3. Test Setup

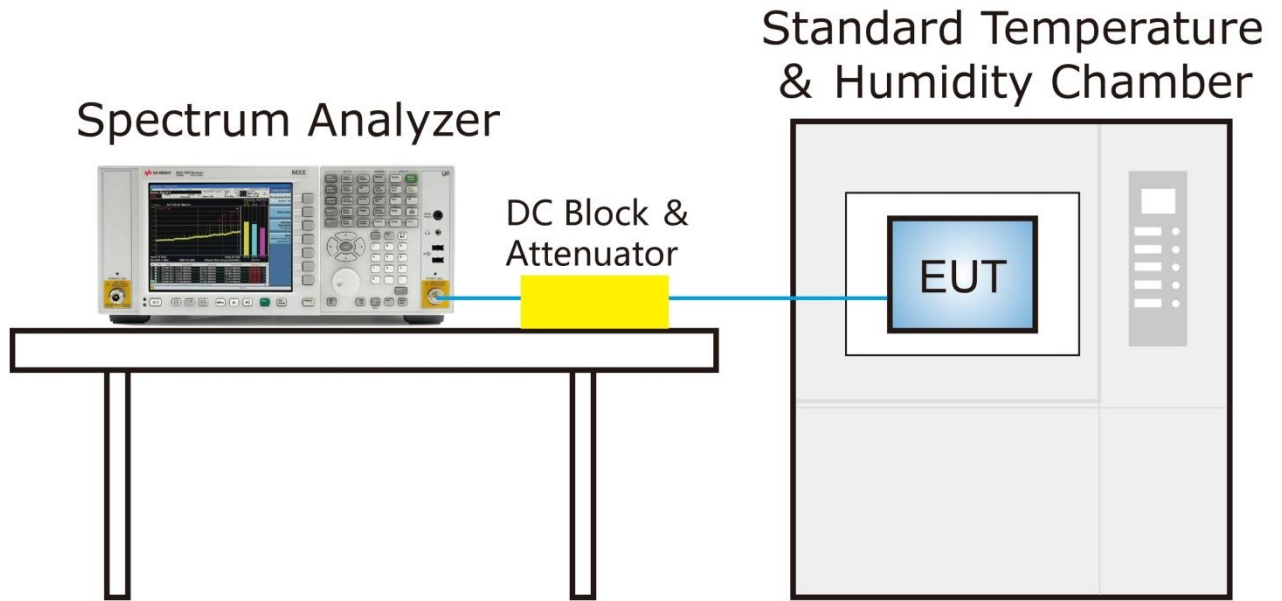

6.7.4. Test Result

Test Site	WZ-TR3	Test Engineer	Amy Zhang
Test Date	2020/12/02	Test Mode	5500MHz (Carrier Mode)

Voltage (%)	Power (VAC)	Temp (°C)	Frequency Tolerance (ppm)			
			0 minutes	2 minutes	5 minutes	10 minutes
100%	120	- 5	-30.71	-30.55	-30.62	-30.79
		5	-30.72	-30.51	-30.77	-30.65
		+ 15	-30.54	-30.42	-30.68	-30.92
		+ 25	-31.05	-31.24	-30.95	-31.03
		+ 35	-31.21	-31.02	-31.08	-31.02
		+ 45	-31.04	-31.07	-31.56	-31.77
115%	138	+ 20	-31.02	-31.05	-31.01	-31.12
85%	102	+ 20	-31.04	-31.22	-31.25	-31.36

Note: Frequency Tolerance (ppm) = $\{[\text{Measured Frequency (MHz)} - \text{Declared Frequency (MHz)}] / \text{Declared Frequency (MHz)}\} * 10^6$.

6.8. Radiated Spurious Emission Measurement

6.8.1. Test Limit

All out of band emissions appearing in a restricted band as specified in Section 15.205 of the Title 47 CFR must not exceed the limits shown in Table per Section 15.209.

FCC Part 15 Subpart C Paragraph 15.209		
Frequency (MHz)	Field Strength ($\mu\text{V/m}$)	Measured Distance (m)
0.009 - 0.490	2400/F (kHz)	300
0.490 - 1.705	24000/F (kHz)	30
1.705 - 30	30	30
30 - 88	100	3
88 - 216	150	3
216 - 960	200	3
Above 960	500	3

6.8.2. Test Procedure Used

KDB 789033 D02v02r01- Section G

6.8.3. Test Setting

Table 1 - RBW as a function of frequency

Frequency	RBW
9 ~ 150 kHz	200 ~ 300 Hz
0.15 ~ 30 MHz	9 ~ 10 kHz
30 ~ 1000 MHz	100 ~ 120 kHz
> 1000 MHz	1 MHz

Quasi-Peak Measurements below 1GHz

1. Analyzer center frequency was set to the frequency of the radiated spurious emission of interest
2. Span was set greater than 1MHz
3. RBW = as specified in Table 1
4. Detector = CISPR quasi-peak
5. Sweep time = auto couple
6. Trace was allowed to stabilize

Peak Measurements above 1GHz

1. Analyzer center frequency was set to the frequency of the radiated spurious emission of interest
2. RBW = 1MHz
3. VBW = 3MHz
4. Detector = peak
5. Sweep time = auto couple
6. Trace mode = max hold
7. Trace was allowed to stabilize

Average Measurements above 1GHz (Method VB)

1. Analyzer center frequency was set to the frequency of the radiated spurious emission of interest
2. RBW = 1MHz
3. VBW; If the EUT is configured to transmit with duty cycle $\geq 98\%$, set VBW = 10Hz
If the EUT duty cycle is $< 98\%$, set VBW $\geq 1/T$. T is the minimum transmission duration
4. Detector = Peak
5. Sweep time = auto
6. Trace mode = max hold
7. Trace was allowed to stabilize

6.8.4. Test Setup

Below 1GHz Test Setup:

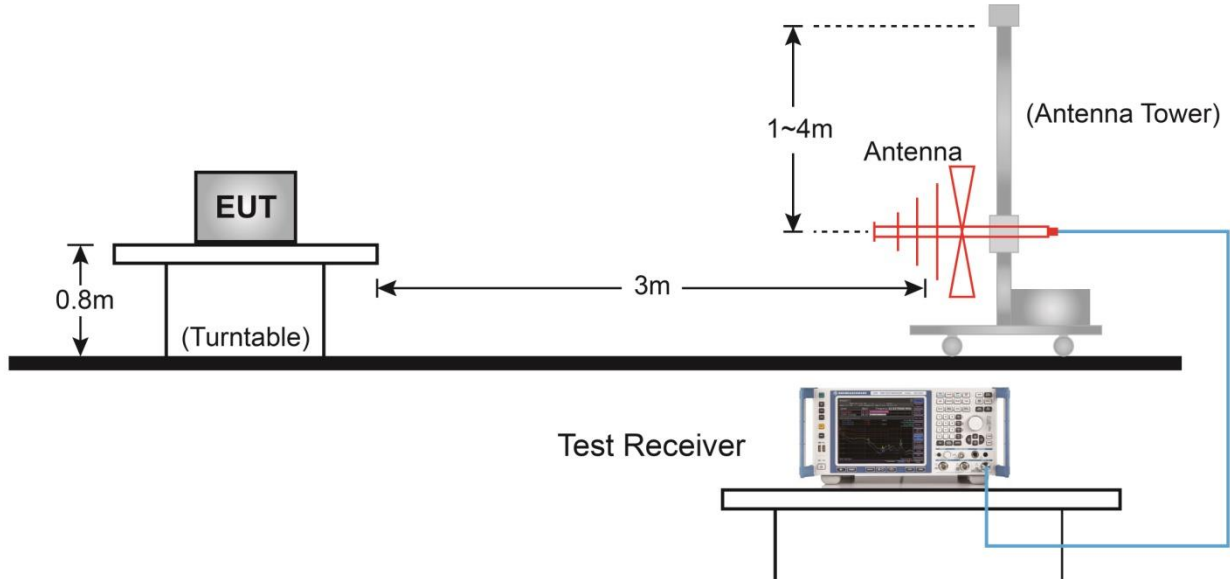

Above 1GHz Test Setup:

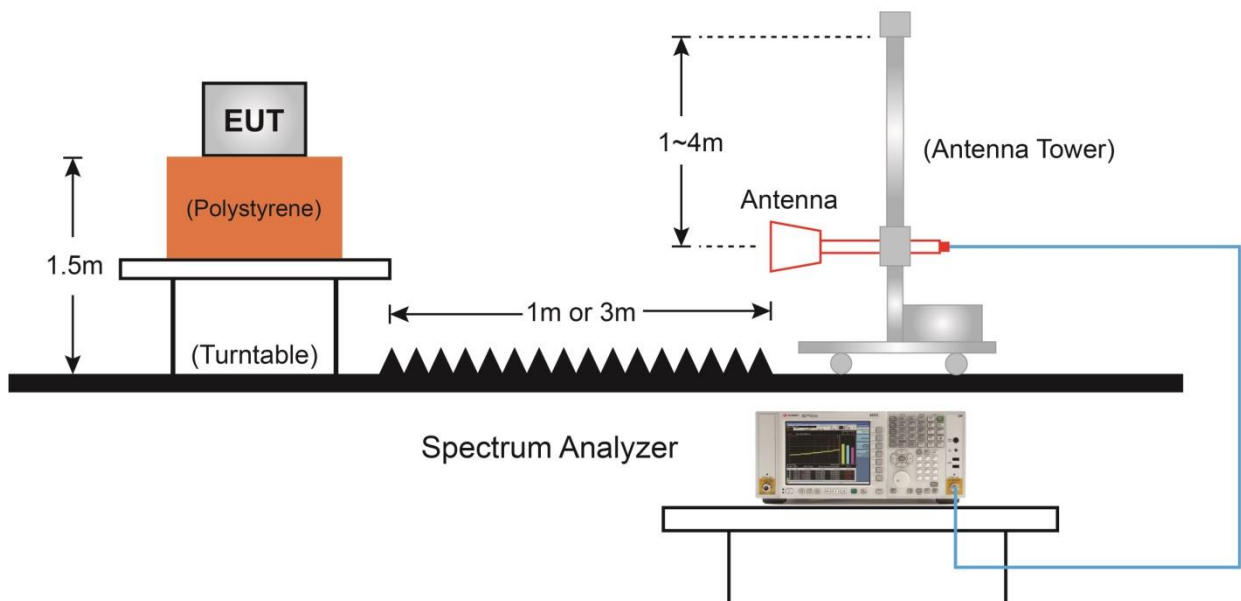

6.8.5. Test Result

Test Site	WZ-AC2	Test Engineer	Buter Shi
Test Date	2021/01/02	Test Channel	36
Test Mode	802.11a (CDD Mode)		
Remark	1. Average measurement was not performed if peak level lower than average limit. 2. Other frequency was 20dB below limit line within 1-18GHz, there is not show in the report.		

Mark	Frequency (MHz)	Reading Level (dBμV)	Factor (dB)	Measure Level (dBμV/m)	Limit (dBμV/m)	Margin (dB)	Detector	Polarization
*	8896.5	37.9	12.0	49.9	68.2	-18.3	Peak	Horizontal
*	10358.5	41.8	15.2	57.0	68.2	-11.2	Peak	Horizontal
	11820.5	38.3	14.9	53.2	74.0	-20.8	Peak	Horizontal
	15543.5	43.3	14.9	58.2	74.0	-15.8	Peak	Horizontal
	15543.5	30.1	14.9	45.0	54.0	-9.0	Average	Horizontal
*	8735.0	36.2	11.9	48.1	68.2	-20.1	Peak	Vertical
*	10367.0	39.9	14.9	54.8	68.2	-13.4	Peak	Vertical
	11251.0	37.6	15.3	52.9	74.0	-21.1	Peak	Vertical
	15535.0	42.1	14.9	57.0	74.0	-17.0	Peak	Vertical
	15535.0	29.7	14.9	44.6	54.0	-9.4	Average	Vertical

Note 1: "*" is not in restricted band, its limit is -27dBm/MHz. At a distance of 3 meters, the field strength limit in dBμV/m can be determined by adding a "conversion" factor of 95.2dB to the EIRP limit of -27dBm/MHz to obtain the limit for out of band spurious emissions.

Note 2: Measure Level (dBμV/m) = Reading Level (dBμV) + Factor (dB)

Factor (dB) = Cable Loss (dB) + Antenna Factor (dB/m) - Pre_Amplifier Gain (dB)

Test Site	WZ-AC2	Test Engineer	Buter Shi
Test Date	2021/01/02	Test Channel	44
Test Mode	802.11a (CDD Mode)		
Remark	1. Average measurement was not performed if peak level lower than average limit. 2. Other frequency was 20dB below limit line within 1-18GHz, there is not show in the report.		

Mark	Frequency (MHz)	Reading Level (dBμV)	Factor (dB)	Measure Level (dBμV/m)	Limit (dBμV/m)	Margin (dB)	Detector	Polarization
*	8820.0	36.3	12.3	48.6	68.2	-19.6	Peak	Horizontal
*	10443.5	40.1	14.8	54.9	68.2	-13.3	Peak	Horizontal
	11676.0	37.2	15.3	52.5	74.0	-21.5	Peak	Horizontal
	15654.0	43.0	15.2	58.2	74.0	-15.8	Peak	Horizontal
	15654.0	30.3	15.2	45.5	54.0	-8.5	Average	Horizontal
*	8947.5	37.5	12.0	49.5	68.2	-18.7	Peak	Vertical
*	10180.0	37.0	14.8	51.8	68.2	-16.4	Peak	Vertical
	11438.0	37.6	15.5	53.1	74.0	-20.9	Peak	Vertical
	15662.5	39.0	15.0	54.0	74.0	-20.0	Peak	Vertical
	15662.5	28.8	15.0	43.8	54.0	-10.2	Average	Vertical

Note 1: "*" is not in restricted band, its limit is -27dBm/MHz. At a distance of 3 meters, the field strength limit in dBμV/m can be determined by adding a "conversion" factor of 95.2dB to the EIRP limit of -27dBm/MHz to obtain the limit for out of band spurious emissions.

Note 2: Measure Level (dBμV/m) = Reading Level (dBμV) + Factor (dB)

Factor (dB) = Cable Loss (dB) + Antenna Factor (dB/m) - Pre_Amplifier Gain (dB)

Test Site	WZ-AC2	Test Engineer	Buter Shi
Test Date	2021/01/02	Test Channel	48
Test Mode	802.11a (CDD Mode)		
Remark	1. Average measurement was not performed if peak level lower than average limit. 2. Other frequency was 20dB below limit line within 1-18GHz, there is not show in the report.		

Mark	Frequency (MHz)	Reading Level (dBμV)	Factor (dB)	Measure Level (dBμV/m)	Limit (dBμV/m)	Margin (dB)	Detector	Polarization
*	8735.0	35.7	11.9	47.6	68.2	-20.6	Peak	Horizontal
*	10477.5	40.2	15.3	55.5	68.2	-12.7	Peak	Horizontal
	11965.0	37.5	14.8	52.3	74.0	-21.7	Peak	Horizontal
	15722.0	45.4	14.7	60.1	74.0	-13.9	Peak	Horizontal
	15722.0	31.8	14.7	46.5	54.0	-7.5	Average	Horizontal
*	8811.5	36.2	12.3	48.5	68.2	-19.7	Peak	Vertical
*	9806.0	36.2	14.3	50.5	68.2	-17.7	Peak	Vertical
	11361.5	37.2	15.5	52.7	74.0	-21.3	Peak	Vertical
	15713.5	39.4	14.7	54.1	74.0	-19.9	Peak	Vertical
	15713.5	29.6	14.7	44.3	54.0	-9.7	Average	Vertical

Note 1: "*" is not in restricted band, its limit is -27dBm/MHz. At a distance of 3 meters, the field strength limit in dBμV/m can be determined by adding a "conversion" factor of 95.2dB to the EIRP limit of -27dBm/MHz to obtain the limit for out of band spurious emissions.

Note 2: Measure Level (dBμV/m) = Reading Level (dBμV) + Factor (dB)

Factor (dB) = Cable Loss (dB) + Antenna Factor (dB/m) - Pre_Amplifier Gain (dB)

Test Site	WZ-AC2	Test Engineer	Buter Shi
Test Date	2021/01/02	Test Channel	52
Test Mode	802.11a (CDD Mode)		
Remark	1. Average measurement was not performed if peak level lower than average limit. 2. Other frequency was 20dB below limit line within 1-18GHz, there is not show in the report.		

Mark	Frequency (MHz)	Reading Level (dBμV)	Factor (dB)	Measure Level (dBμV/m)	Limit (dBμV/m)	Margin (dB)	Detector	Polarization
*	8658.5	35.7	11.9	47.6	68.2	-20.6	Peak	Horizontal
*	10520.0	39.1	15.2	54.3	68.2	-13.9	Peak	Horizontal
	11846.0	37.8	15.0	52.8	74.0	-21.2	Peak	Horizontal
	15773.0	46.1	14.6	60.7	74.0	-13.3	Peak	Horizontal
	15773.0	30.2	14.6	44.8	54.0	-9.2	Average	Horizontal
*	8947.5	37.9	12.0	49.9	68.2	-18.3	Peak	Vertical
*	10137.5	34.7	14.6	49.3	68.2	-18.9	Peak	Vertical
	11829.0	37.4	14.9	52.3	74.0	-21.7	Peak	Vertical
	15773.0	40.0	14.6	54.6	74.0	-19.4	Peak	Vertical
	15773.0	28.9	14.6	43.5	54.0	-10.5	Average	Vertical

Note 1: "*" is not in restricted band, its limit is -27dBm/MHz. At a distance of 3 meters, the field strength limit in dBμV/m can be determined by adding a "conversion" factor of 95.2dB to the EIRP limit of -27dBm/MHz to obtain the limit for out of band spurious emissions.

Note 2: Measure Level (dBμV/m) = Reading Level (dBμV) + Factor (dB)

Factor (dB) = Cable Loss (dB) + Antenna Factor (dB/m) - Pre_Amplifier Gain (dB)

Test Site	WZ-AC2	Test Engineer	Buter Shi
Test Date	2021/01/02	Test Channel	60
Test Mode	802.11a (CDD Mode)		
Remark	1. Average measurement was not performed if peak level lower than average limit. 2. Other frequency was 20dB below limit line within 1-18GHz, there is not show in the report.		

Mark	Frequency (MHz)	Reading Level (dBμV)	Factor (dB)	Measure Level (dBμV/m)	Limit (dBμV/m)	Margin (dB)	Detector	Polarization
*	8650.0	36.7	11.9	48.6	68.2	-19.6	Peak	Horizontal
*	10129.0	36.8	14.8	51.6	68.2	-16.6	Peak	Horizontal
	10605.0	40.1	15.3	55.4	74.0	-18.6	Peak	Horizontal
	10605.0	26.0	15.3	41.3	54.0	-12.7	Average	Horizontal
	15892.0	46.5	14.6	61.1	74.0	-12.9	Peak	Horizontal
	15892.0	34.0	14.6	48.6	54.0	-5.4	Average	Vertical
*	8820.0	35.9	12.3	48.2	68.2	-20.0	Peak	Vertical
*	10596.5	36.6	15.5	52.1	68.2	-16.1	Peak	Vertical
	11693.0	37.0	15.3	52.3	74.0	-21.7	Peak	Vertical
	15892.0	40.4	14.6	55.0	74.0	-19.0	Peak	Vertical
	15892.0	29.6	14.6	44.2	54.0	-9.8	Average	Vertical

Note 1: "*" is not in restricted band, its limit is -27dBm/MHz. At a distance of 3 meters, the field strength limit in dBμV/m can be determined by adding a "conversion" factor of 95.2dB to the EIRP limit of -27dBm/MHz to obtain the limit for out of band spurious emissions.

Note 2: Measure Level (dBμV/m) = Reading Level (dBμV) + Factor (dB)

Factor (dB) = Cable Loss (dB) + Antenna Factor (dB/m) - Pre_Amplifier Gain (dB)

Test Site	WZ-AC2	Test Engineer	Buter Shi
Test Date	2021/01/02	Test Channel	64
Test Mode	802.11a (CDD Mode)		
Remark	1. Average measurement was not performed if peak level lower than average limit. 2. Other frequency was 20dB below limit line within 1-18GHz, there is not show in the report.		

Mark	Frequency (MHz)	Reading Level (dBμV)	Factor (dB)	Measure Level (dBμV/m)	Limit (dBμV/m)	Margin (dB)	Detector	Polarization
*	8616.0	36.9	11.7	48.6	68.2	-19.6	Peak	Horizontal
*	9916.5	36.0	14.1	50.1	68.2	-18.1	Peak	Horizontal
	10639.0	38.5	15.2	53.7	74.0	-20.3	Peak	Horizontal
	15960.0	46.9	14.7	61.6	74.0	-12.4	Peak	Horizontal
	15960.0	32.7	14.7	47.4	54.0	-6.6	Average	Horizontal
*	8735.0	35.8	11.9	47.7	68.2	-20.5	Peak	Vertical
*	9746.5	36.5	14.5	51.0	68.2	-17.2	Peak	Vertical
	10639.0	38.7	15.2	53.9	74.0	-20.1	Peak	Vertical
	15960.0	40.2	14.7	54.9	74.0	-19.1	Peak	Vertical
	15960.0	30.1	14.7	44.8	54.0	-9.2	Average	Vertical

Note 1: "*" is not in restricted band, its limit is -27dBm/MHz. At a distance of 3 meters, the field strength limit in dBμV/m can be determined by adding a "conversion" factor of 95.2dB to the EIRP limit of -27dBm/MHz to obtain the limit for out of band spurious emissions.

Note 2: Measure Level (dBμV/m) = Reading Level (dBμV) + Factor (dB)

Factor (dB) = Cable Loss (dB) + Antenna Factor (dB/m) - Pre_Amplifier Gain (dB)

Test Site	WZ-AC2	Test Engineer	Buter Shi
Test Date	2021/01/02	Test Channel	100
Test Mode	802.11a (CDD Mode)		
Remark	1. Average measurement was not performed if peak level lower than average limit. 2. Other frequency was 20dB below limit line within 1-18GHz, there is not show in the report.		

Mark	Frequency (MHz)	Reading Level (dBμV)	Factor (dB)	Measure Level (dBμV/m)	Limit (dBμV/m)	Margin (dB)	Detector	Polarization
	8216.5	38.0	11.0	49.0	74.0	-25.0	Peak	Horizontal
	11004.5	39.3	15.6	54.9	74.0	-19.1	Peak	Horizontal
	11004.5	27.6	15.6	43.2	54.0	-10.8	Average	Horizontal
*	13036.0	35.9	14.9	50.8	68.2	-17.4	Peak	Horizontal
*	16487.0	47.3	15.9	63.2	68.2	-5.0	Peak	Horizontal
	8403.5	36.3	11.0	47.3	74.0	-26.7	Peak	Vertical
	11497.5	36.7	15.6	52.3	74.0	-21.7	Peak	Vertical
*	12959.5	36.8	14.9	51.7	68.2	-16.5	Peak	Vertical
*	17073.5	37.6	18.7	56.3	68.2	-11.9	Peak	Vertical

Note 1: "*" is not in restricted band, its limit is -27dBm/MHz. At a distance of 3 meters, the field strength limit in dBμV/m can be determined by adding a "conversion" factor of 95.2dB to the EIRP limit of -27dBm/MHz to obtain the limit for out of band spurious emissions.

Note 2: Measure Level (dBμV/m) = Reading Level (dBμV) + Factor (dB)

Factor (dB) = Cable Loss (dB) + Antenna Factor (dB/m) - Pre_Amplifier Gain (dB)

Test Site	WZ-AC2	Test Engineer	Buter Shi
Test Date	2021/01/02	Test Channel	116
Test Mode	802.11a (CDD Mode)		
Remark	1. Average measurement was not performed if peak level lower than average limit. 2. Other frequency was 20dB below limit line within 1-18GHz, there is not show in the report.		

Mark	Frequency (MHz)	Reading Level (dB μ V)	Factor (dB)	Measure Level (dB μ V/m)	Limit (dB μ V/m)	Margin (dB)	Detector	Polarization
	8352.5	37.5	10.7	48.2	74.0	-25.8	Peak	Horizontal
	11166.0	38.2	15.1	53.3	74.0	-20.7	Peak	Horizontal
*	12993.5	37.5	14.8	52.3	68.2	-15.9	Peak	Horizontal
*	16742.0	44.9	17.8	62.7	68.2	-5.5	Peak	Horizontal
	8267.5	38.2	10.8	49.0	74.0	-25.0	Peak	Vertical
	12186.0	38.0	14.8	52.8	74.0	-21.2	Peak	Vertical
*	13070.0	37.3	14.8	52.1	68.2	-16.1	Peak	Vertical
*	17082.0	37.2	18.9	56.1	68.2	-12.1	Peak	Vertical

Note 1: "*" is not in restricted band, its limit is -27dBm/MHz. At a distance of 3 meters, the field strength limit in dB μ V/m can be determined by adding a "conversion" factor of 95.2dB to the EIRP limit of -27dBm/MHz to obtain the limit for out of band spurious emissions.

Note 2: Measure Level (dB μ V/m) = Reading Level (dB μ V) + Factor (dB)

Factor (dB) = Cable Loss (dB) + Antenna Factor (dB/m) - Pre_Amplifier Gain (dB)

Test Site	WZ-AC2	Test Engineer	Buter Shi
Test Date	2021/01/02	Test Channel	140
Test Mode	802.11a (CDD Mode)		
Remark	1. Average measurement was not performed if peak level lower than average limit. 2. Other frequency was 20dB below limit line within 1-18GHz, there is not show in the report.		

Mark	Frequency (MHz)	Reading Level (dBμV)	Factor (dB)	Measure Level (dBμV/m)	Limit (dBμV/m)	Margin (dB)	Detector	Polarization
	8242.0	37.1	10.9	48.0	74.0	-26.0	Peak	Horizontal
	11395.5	39.0	15.2	54.2	74.0	-19.8	Peak	Horizontal
	11395.5	28.9	15.2	44.1	54.0	-9.9	Average	Horizontal
*	12891.5	35.8	14.7	50.5	68.2	-17.7	Peak	Horizontal
*	17099.0	45.8	18.8	64.6	68.2	-3.6	Peak	Horizontal
	8293.0	35.7	10.7	46.4	74.0	-27.6	Peak	Vertical
	11132.0	36.5	15.2	51.7	74.0	-22.3	Peak	Vertical
*	12951.0	35.4	14.8	50.2	68.2	-18.0	Peak	Vertical
*	17090.5	38.3	18.9	57.2	68.2	-11.0	Peak	Vertical

Note 1: "*" is not in restricted band, its limit is -27dBm/MHz. At a distance of 3 meters, the field strength limit in dBμV/m can be determined by adding a "conversion" factor of 95.2dB to the EIRP limit of -27dBm/MHz to obtain the limit for out of band spurious emissions.

Note 2: Measure Level (dBμV/m) = Reading Level (dBμV) + Factor (dB)

Factor (dB) = Cable Loss (dB) + Antenna Factor (dB/m) - Pre_Amplifier Gain (dB)

Test Site	WZ-AC2	Test Engineer	Buter Shi
Test Date	2021/01/02	Test Channel	144
Test Mode	802.11a (CDD Mode)		
Remark	1. Average measurement was not performed if peak level lower than average limit. 2. Other frequency was 20dB below limit line within 1-18GHz, there is not show in the report.		

Mark	Frequency (MHz)	Reading Level (dB μ V)	Factor (dB)	Measure Level (dB μ V/m)	Limit (dB μ V/m)	Margin (dB)	Detector	Polarization
	8191.0	38.1	10.7	48.8	74.0	-25.2	Peak	Horizontal
	11438.0	38.4	15.5	53.9	74.0	-20.1	Peak	Horizontal
*	12849.0	36.5	14.6	51.1	68.2	-17.1	Peak	Horizontal
*	17158.5	44.7	18.3	63.0	68.2	-5.2	Peak	Horizontal
	8225.0	37.9	11.1	49.0	74.0	-25.0	Peak	Vertical
	10945.0	36.4	15.8	52.2	74.0	-21.8	Peak	Vertical
*	12849.0	35.6	14.6	50.2	68.2	-18.0	Peak	Vertical
*	17158.5	40.0	18.3	58.3	68.2	-9.9	Peak	Vertical

Note 1: "*" is not in restricted band, its limit is -27dBm/MHz. At a distance of 3 meters, the field strength limit in dB μ V/m can be determined by adding a "conversion" factor of 95.2dB to the EIRP limit of -27dBm/MHz to obtain the limit for out of band spurious emissions.

Note 2: Measure Level (dB μ V/m) = Reading Level (dB μ V) + Factor (dB)

Factor (dB) = Cable Loss (dB) + Antenna Factor (dB/m) - Pre_Amplifier Gain (dB)

Test Site	WZ-AC2	Test Engineer	Buter Shi
Test Date	2021/01/02	Test Channel	149
Test Mode	802.11a (CDD Mode)		
Remark	1. Average measurement was not performed if peak level lower than average limit. 2. Other frequency was 20dB below limit line within 1-18GHz, there is not show in the report.		

Mark	Frequency (MHz)	Reading Level (dBμV)	Factor (dB)	Measure Level (dBμV/m)	Limit (dBμV/m)	Margin (dB)	Detector	Polarization
	8276.0	36.1	10.6	46.7	74.0	-27.3	Peak	Horizontal
	11489.0	37.9	15.6	53.5	74.0	-20.5	Peak	Horizontal
*	12891.5	36.6	14.7	51.3	68.2	-16.9	Peak	Horizontal
*	17235.0	45.3	18.0	63.3	68.2	-4.9	Peak	Horizontal
	8276.0	36.9	10.6	47.5	74.0	-26.5	Peak	Vertical
	11489.0	37.1	15.6	52.7	74.0	-21.3	Peak	Vertical
*	12985.0	35.3	14.7	50.0	68.2	-18.2	Peak	Vertical
*	17243.5	41.1	18.0	59.1	68.2	-9.1	Peak	Vertical

Note 1: "*" is not in restricted band, its limit is -27dBm/MHz. At a distance of 3 meters, the field strength limit in dBμV/m can be determined by adding a "conversion" factor of 95.2dB to the EIRP limit of -27dBm/MHz to obtain the limit for out of band spurious emissions.

Note 2: Measure Level (dBμV/m) = Reading Level (dBμV) + Factor (dB)

Factor (dB) = Cable Loss (dB) + Antenna Factor (dB/m) - Pre_Amplifier Gain (dB)

Test Site	WZ-AC2	Test Engineer	Buter Shi
Test Date	2021/01/02	Test Channel	157
Test Mode	802.11a (CDD Mode)		
Remark	1. Average measurement was not performed if peak level lower than average limit. 2. Other frequency was 20dB below limit line within 1-18GHz, there is not show in the report.		

Mark	Frequency (MHz)	Reading Level (dBμV)	Factor (dB)	Measure Level (dBμV/m)	Limit (dBμV/m)	Margin (dB)	Detector	Polarization
	8301.5	38.1	10.8	48.9	74.0	-25.1	Peak	Horizontal
	11565.5	39.4	15.2	54.6	74.0	-19.4	Peak	Horizontal
	11565.5	30.4	15.2	45.6	54.0	-8.4	Average	Horizontal
*	13112.5	35.9	14.8	50.7	68.2	-17.5	Peak	Horizontal
*	17345.5	46.5	18.0	64.5	68.2	-3.7	Peak	Horizontal
	8369.5	37.7	10.7	48.4	74.0	-25.6	Peak	Vertical
	11591.0	37.8	15.2	53.0	74.0	-21.0	Peak	Vertical
*	12959.5	36.1	14.9	51.0	68.2	-17.2	Peak	Vertical
*	17354.0	41.9	18.1	60.0	68.2	-8.2	Peak	Vertical

Note 1: "*" is not in restricted band, its limit is -27dBm/MHz. At a distance of 3 meters, the field strength limit in dBμV/m can be determined by adding a "conversion" factor of 95.2dB to the EIRP limit of -27dBm/MHz to obtain the limit for out of band spurious emissions.

Note 2: Measure Level (dBμV/m) = Reading Level (dBμV) + Factor (dB)

Factor (dB) = Cable Loss (dB) + Antenna Factor (dB/m) - Pre_Amplifier Gain (dB)

Test Site	WZ-AC2	Test Engineer	Buter Shi
Test Date	2021/01/02	Test Channel	165
Test Mode	802.11a (CDD Mode)		
Remark	1. Average measurement was not performed if peak level lower than average limit. 2. Other frequency was 20dB below limit line within 1-18GHz, there is not show in the report.		

Mark	Frequency (MHz)	Reading Level (dB μ V)	Factor (dB)	Measure Level (dB μ V/m)	Limit (dB μ V/m)	Margin (dB)	Detector	Polarization
	8242.0	36.7	10.9	47.6	74.0	-26.4	Peak	Horizontal
	11659.0	38.4	15.0	53.4	74.0	-20.6	Peak	Horizontal
*	13044.5	37.4	14.8	52.2	68.2	-16.0	Peak	Horizontal
*	17464.5	46.6	19.6	66.2	68.2	-2.0	Peak	Horizontal
	8310.0	37.5	11.0	48.5	74.0	-25.5	Peak	Vertical
	11676.0	37.9	15.3	53.2	74.0	-20.8	Peak	Vertical
*	12891.5	36.1	14.7	50.8	68.2	-17.4	Peak	Vertical
*	17473.0	40.0	19.5	59.5	68.2	-8.7	Peak	Vertical

Note 1: "*" is not in restricted band, its limit is -27dBm/MHz. At a distance of 3 meters, the field strength limit in dB μ V/m can be determined by adding a "conversion" factor of 95.2dB to the EIRP limit of -27dBm/MHz to obtain the limit for out of band spurious emissions.

Note 2: Measure Level (dB μ V/m) = Reading Level (dB μ V) + Factor (dB)

Factor (dB) = Cable Loss (dB) + Antenna Factor (dB/m) - Pre_Amplifier Gain (dB)

Test Site	WZ-AC2	Test Engineer	Buter Shi
Test Date	2021/01/02	Test Channel	36
Test Mode	802.11n-HT20 (CDD Mode)		
Remark	1. Average measurement was not performed if peak level lower than average limit. 2. Other frequency was 20dB below limit line within 1-18GHz, there is not show in the report.		

Mark	Frequency (MHz)	Reading Level (dB μ V)	Factor (dB)	Measure Level (dB μ V/m)	Limit (dB μ V/m)	Margin (dB)	Detector	Polarization
*	8692.5	36.5	12.1	48.6	68.2	-19.6	Peak	Horizontal
*	10350.0	41.3	15.0	56.3	68.2	-11.9	Peak	Horizontal
	11693.0	38.1	15.3	53.4	74.0	-20.6	Peak	Horizontal
	15526.5	45.5	14.9	60.4	74.0	-13.6	Peak	Horizontal
	15526.5	30.2	14.9	45.1	54.0	-8.9	Average	Horizontal
*	8752.0	35.1	12.0	47.1	68.2	-21.1	Peak	Vertical
*	10367.0	39.0	14.9	53.9	68.2	-14.3	Peak	Vertical
	11506.0	36.5	15.3	51.8	74.0	-22.2	Peak	Vertical
	15526.5	40.1	14.9	55.0	74.0	-19.0	Peak	Vertical
	15526.5	30.1	14.9	45.0	54.0	-9.0	Average	Vertical

Note 1: "*" is not in restricted band, its limit is -27dBm/MHz. At a distance of 3 meters, the field strength limit in dB μ V/m can be determined by adding a "conversion" factor of 95.2dB to the EIRP limit of -27dBm/MHz to obtain the limit for out of band spurious emissions.

Note 2: Measure Level (dB μ V/m) = Reading Level (dB μ V) + Factor (dB)

Factor (dB) = Cable Loss (dB) + Antenna Factor (dB/m) - Pre_Amplifier Gain (dB)

Test Site	WZ-AC2	Test Engineer	Buter Shi
Test Date	2021/01/02	Test Channel	44
Test Mode	802.11n-HT20 (CDD Mode)		
Remark	1. Average measurement was not performed if peak level lower than average limit. 2. Other frequency was 20dB below limit line within 1-18GHz, there is not show in the report.		

Mark	Frequency (MHz)	Reading Level (dBμV)	Factor (dB)	Measure Level (dBμV/m)	Limit (dBμV/m)	Margin (dB)	Detector	Polarization
*	8811.5	35.7	12.3	48.0	68.2	-20.2	Peak	Horizontal
*	10435.0	38.5	15.3	53.8	68.2	-14.4	Peak	Horizontal
	11803.5	37.1	14.8	51.9	74.0	-22.1	Peak	Horizontal
	15662.5	45.7	15.0	60.7	74.0	-13.3	Peak	Horizontal
	15662.5	30.2	15.0	45.2	54.0	-8.8	Average	Horizontal
*	8735.0	36.7	11.9	48.6	68.2	-19.6	Peak	Vertical
*	9976.0	36.1	14.1	50.2	68.2	-18.0	Peak	Vertical
	11225.5	37.6	14.9	52.5	74.0	-21.5	Peak	Vertical
	15645.5	37.3	15.2	52.5	74.0	-21.5	Peak	Vertical

Note 1: "*" is not in restricted band, its limit is -27dBm/MHz. At a distance of 3 meters, the field strength limit in dBμV/m can be determined by adding a "conversion" factor of 95.2dB to the EIRP limit of -27dBm/MHz to obtain the limit for out of band spurious emissions.

Note 2: Measure Level (dBμV/m) = Reading Level (dBμV) + Factor (dB)

Factor (dB) = Cable Loss (dB) + Antenna Factor (dB/m) - Pre_Amplifier Gain (dB)

Test Site	WZ-AC2	Test Engineer	Buter Shi
Test Date	2021/01/02	Test Channel	48
Test Mode	802.11n-HT20 (CDD Mode)		
Remark	1. Average measurement was not performed if peak level lower than average limit. 2. Other frequency was 20dB below limit line within 1-18GHz, there is not show in the report.		

Mark	Frequency (MHz)	Reading Level (dBμV)	Factor (dB)	Measure Level (dBμV/m)	Limit (dBμV/m)	Margin (dB)	Detector	Polarization
*	8658.5	35.3	11.9	47.2	68.2	-21.0	Peak	Horizontal
*	10477.5	37.6	15.3	52.9	68.2	-15.3	Peak	Horizontal
	11659.0	37.0	15.0	52.0	74.0	-22.0	Peak	Horizontal
	15722.0	44.1	14.7	58.8	74.0	-15.2	Peak	Horizontal
	15722.0	30.1	14.7	44.8	54.0	-9.2	Average	Horizontal
*	8735.0	35.3	11.9	47.2	68.2	-21.0	Peak	Vertical
*	10469.0	37.6	15.1	52.7	68.2	-15.5	Peak	Vertical
	11072.5	36.2	15.3	51.5	74.0	-22.5	Peak	Vertical
	15705.0	39.6	14.9	54.5	74.0	-19.5	Peak	Vertical
	15705.0	30.6	14.9	45.5	54.0	-8.5	Average	Vertical

Note 1: "*" is not in restricted band, its limit is -27dBm/MHz. At a distance of 3 meters, the field strength limit in dBμV/m can be determined by adding a "conversion" factor of 95.2dB to the EIRP limit of -27dBm/MHz to obtain the limit for out of band spurious emissions.

Note 2: Measure Level (dBμV/m) = Reading Level (dBμV) + Factor (dB)

Factor (dB) = Cable Loss (dB) + Antenna Factor (dB/m) - Pre_Amplifier Gain (dB)

Test Site	WZ-AC2	Test Engineer	Buter Shi
Test Date	2021/01/02	Test Channel	52
Test Mode	802.11n-HT20 (CDD Mode)		
Remark	1. Average measurement was not performed if peak level lower than average limit. 2. Other frequency was 20dB below limit line within 1-18GHz, there is not show in the report.		

Mark	Frequency (MHz)	Reading Level (dBμV)	Factor (dB)	Measure Level (dBμV/m)	Limit (dBμV/m)	Margin (dB)	Detector	Polarization
*	8658.5	37.2	11.9	49.1	68.2	-19.1	Peak	Horizontal
*	10520.0	36.9	15.2	52.1	68.2	-16.1	Peak	Horizontal
	11693.0	37.0	15.3	52.3	74.0	-21.7	Peak	Horizontal
	15773.0	46.1	14.6	60.7	74.0	-13.3	Peak	Horizontal
	15773.0	30.6	14.6	45.2	54.0	-8.8	Average	Horizontal
*	8769.0	34.8	11.9	46.7	68.2	-21.5	Peak	Vertical
*	10528.5	36.0	15.3	51.3	68.2	-16.9	Peak	Vertical
	11446.5	37.4	15.4	52.8	74.0	-21.2	Peak	Vertical
	15424.5	37.3	15.3	52.6	74.0	-21.4	Peak	Vertical

Note 1: "*" is not in restricted band, its limit is -27dBm/MHz. At a distance of 3 meters, the field strength limit in dBμV/m can be determined by adding a "conversion" factor of 95.2dB to the EIRP limit of -27dBm/MHz to obtain the limit for out of band spurious emissions.

Note 2: Measure Level (dBμV/m) = Reading Level (dBμV) + Factor (dB)

Factor (dB) = Cable Loss (dB) + Antenna Factor (dB/m) - Pre_Amplifier Gain (dB)

Test Site	WZ-AC2	Test Engineer	Buter Shi
Test Date	2021/01/02	Test Channel	60
Test Mode	802.11n-HT20 (CDD Mode)		
Remark	1. Average measurement was not performed if peak level lower than average limit. 2. Other frequency was 20dB below limit line within 1-18GHz, there is not show in the report.		

Mark	Frequency (MHz)	Reading Level (dBμV)	Factor (dB)	Measure Level (dBμV/m)	Limit (dBμV/m)	Margin (dB)	Detector	Polarization
*	10120.5	35.3	14.6	49.9	68.2	-18.3	Peak	Horizontal
*	10596.5	38.1	15.5	53.6	68.2	-14.6	Peak	Horizontal
	11786.5	36.3	14.9	51.2	74.0	-22.8	Peak	Horizontal
	15900.5	42.2	14.5	56.7	74.0	-17.3	Peak	Horizontal
	15900.5	30.2	14.5	44.7	54.0	-9.3	Average	Horizontal
*	8820.0	36.0	12.3	48.3	68.2	-19.9	Peak	Vertical
*	9959.0	36.5	13.9	50.4	68.2	-17.8	Peak	Vertical
	11854.5	36.7	15.1	51.8	74.0	-22.2	Peak	Vertical
	15900.5	38.9	14.5	53.4	74.0	-20.6	Peak	Vertical

Note 1: "*" is not in restricted band, its limit is -27dBm/MHz. At a distance of 3 meters, the field strength limit in dBμV/m can be determined by adding a "conversion" factor of 95.2dB to the EIRP limit of -27dBm/MHz to obtain the limit for out of band spurious emissions.

Note 2: Measure Level (dBμV/m) = Reading Level (dBμV) + Factor (dB)

Factor (dB) = Cable Loss (dB) + Antenna Factor (dB/m) - Pre_Amplifier Gain (dB)

Test Site	WZ-AC2	Test Engineer	Buter Shi
Test Date	2021/01/02	Test Channel	64
Test Mode	802.11n-HT20 (CDD Mode)		
Remark	1. Average measurement was not performed if peak level lower than average limit. 2. Other frequency was 20dB below limit line within 1-18GHz, there is not show in the report.		

Mark	Frequency (MHz)	Reading Level (dB μ V)	Factor (dB)	Measure Level (dB μ V/m)	Limit (dB μ V/m)	Margin (dB)	Detector	Polarization
*	8616.0	35.8	11.7	47.5	68.2	-20.7	Peak	Horizontal
*	9746.5	35.3	14.5	49.8	68.2	-18.4	Peak	Horizontal
	10630.5	38.8	15.2	54.0	74.0	-20.0	Peak	Horizontal
	15951.5	45.6	14.7	60.3	74.0	-13.7	Peak	Horizontal
*	8658.5	36.1	11.9	48.0	68.2	-20.2	Peak	Vertical
*	9942.0	34.6	14.1	48.7	68.2	-19.5	Peak	Vertical
	11200.0	36.7	15.0	51.7	74.0	-22.3	Peak	Vertical
	15569.0	36.5	15.3	51.8	74.0	-22.2	Peak	Vertical

Note 1: "*" is not in restricted band, its limit is -27dBm/MHz. At a distance of 3 meters, the field strength limit in dB μ V/m can be determined by adding a "conversion" factor of 95.2dB to the EIRP limit of -27dBm/MHz to obtain the limit for out of band spurious emissions.

Note 2: Measure Level (dB μ V/m) = Reading Level (dB μ V) + Factor (dB)

Factor (dB) = Cable Loss (dB) + Antenna Factor (dB/m) - Pre_Amplifier Gain (dB)

Test Site	WZ-AC2	Test Engineer	Buter Shi
Test Date	2021/01/02	Test Channel	100
Test Mode	802.11n-HT20 (CDD Mode)		
Remark	1. Average measurement was not performed if peak level lower than average limit. 2. Other frequency was 20dB below limit line within 1-18GHz, there is not show in the report.		

Mark	Frequency (MHz)	Reading Level (dBμV)	Factor (dB)	Measure Level (dBμV/m)	Limit (dBμV/m)	Margin (dB)	Detector	Polarization
	8344.0	35.8	10.7	46.5	74.0	-27.5	Peak	Horizontal
	11013.0	36.9	15.5	52.4	74.0	-21.6	Peak	Horizontal
*	12866.0	36.3	14.8	51.1	68.2	-17.1	Peak	Horizontal
*	16478.5	42.6	15.8	58.4	68.2	-9.8	Peak	Horizontal
	8216.5	37.9	11.0	48.9	74.0	-25.1	Peak	Vertical
	11514.5	36.1	15.2	51.3	74.0	-22.7	Peak	Vertical
*	13070.0	37.3	14.8	52.1	68.2	-16.1	Peak	Vertical
*	17082.0	36.7	18.9	55.6	68.2	-12.6	Peak	Vertical

Note 1: "*" is not in restricted band, its limit is -27dBm/MHz. At a distance of 3 meters, the field strength limit in dBμV/m can be determined by adding a "conversion" factor of 95.2dB to the EIRP limit of -27dBm/MHz to obtain the limit for out of band spurious emissions.

Note 2: Measure Level (dBμV/m) = Reading Level (dBμV) + Factor (dB)

Factor (dB) = Cable Loss (dB) + Antenna Factor (dB/m) - Pre_Amplifier Gain (dB)

Test Site	WZ-AC2	Test Engineer	Buter Shi
Test Date	2021/01/02	Test Channel	116
Test Mode	802.11n-HT20 (CDD Mode)		
Remark	1. Average measurement was not performed if peak level lower than average limit. 2. Other frequency was 20dB below limit line within 1-18GHz, there is not show in the report.		

Mark	Frequency (MHz)	Reading Level (dBμV)	Factor (dB)	Measure Level (dBμV/m)	Limit (dBμV/m)	Margin (dB)	Detector	Polarization
	8446.0	37.5	10.9	48.4	74.0	-25.6	Peak	Horizontal
	11157.5	37.3	15.1	52.4	74.0	-21.6	Peak	Horizontal
*	12840.5	34.5	14.5	49.0	68.2	-19.2	Peak	Horizontal
*	16742.0	45.5	17.8	63.3	68.2	-4.9	Peak	Horizontal
	8165.5	38.1	11.1	49.2	74.0	-24.8	Peak	Vertical
	11166.0	37.1	15.1	52.2	74.0	-21.8	Peak	Vertical
*	12891.5	34.8	14.7	49.5	68.2	-18.7	Peak	Vertical
*	17090.5	36.4	18.9	55.3	68.2	-12.9	Peak	Vertical

Note 1: "*" is not in restricted band, its limit is -27dBm/MHz. At a distance of 3 meters, the field strength limit in dBμV/m can be determined by adding a "conversion" factor of 95.2dB to the EIRP limit of -27dBm/MHz to obtain the limit for out of band spurious emissions.

Note 2: Measure Level (dBμV/m) = Reading Level (dBμV) + Factor (dB)

Factor (dB) = Cable Loss (dB) + Antenna Factor (dB/m) - Pre_Amplifier Gain (dB)

Test Site	WZ-AC2	Test Engineer	Buter Shi
Test Date	2021/01/02	Test Channel	140
Test Mode	802.11n-HT20 (CDD Mode)		
Remark	1. Average measurement was not performed if peak level lower than average limit. 2. Other frequency was 20dB below limit line within 1-18GHz, there is not show in the report.		

Mark	Frequency (MHz)	Reading Level (dB μ V)	Factor (dB)	Measure Level (dB μ V/m)	Limit (dB μ V/m)	Margin (dB)	Detector	Polarization
	8242.0	35.7	10.9	46.6	74.0	-27.4	Peak	Horizontal
	11395.5	38.2	15.2	53.4	74.0	-20.6	Peak	Horizontal
*	12840.5	34.4	14.5	48.9	68.2	-19.3	Peak	Horizontal
*	17099.0	46.0	18.8	64.8	68.2	-3.4	Peak	Horizontal
	8301.5	37.4	10.8	48.2	74.0	-25.8	Peak	Vertical
	11157.5	36.6	15.1	51.7	74.0	-22.3	Peak	Vertical
*	13061.5	37.1	14.8	51.9	68.2	-16.3	Peak	Vertical
*	17090.5	39.9	18.9	58.8	68.2	-9.4	Peak	Vertical

Note 1: "*" is not in restricted band, its limit is -27dBm/MHz. At a distance of 3 meters, the field strength limit in dB μ V/m can be determined by adding a "conversion" factor of 95.2dB to the EIRP limit of -27dBm/MHz to obtain the limit for out of band spurious emissions.

Note 2: Measure Level (dB μ V/m) = Reading Level (dB μ V) + Factor (dB)

Factor (dB) = Cable Loss (dB) + Antenna Factor (dB/m) - Pre_Amplifier Gain (dB)

Test Site	WZ-AC2	Test Engineer	Buter Shi
Test Date	2021/01/02	Test Channel	144
Test Mode	802.11n-HT20 (CDD Mode)		
Remark	1. Average measurement was not performed if peak level lower than average limit. 2. Other frequency was 20dB below limit line within 1-18GHz, there is not show in the report.		

Mark	Frequency (MHz)	Reading Level (dB μ V)	Factor (dB)	Measure Level (dB μ V/m)	Limit (dB μ V/m)	Margin (dB)	Detector	Polarization
	8242.0	36.1	10.9	47.0	74.0	-27.0	Peak	Horizontal
	11429.5	37.6	15.3	52.9	74.0	-21.1	Peak	Horizontal
*	13010.5	34.6	14.8	49.4	68.2	-18.8	Peak	Horizontal
*	17158.5	44.7	18.3	63.0	68.2	-5.2	Peak	Horizontal
	8199.5	37.3	10.8	48.1	74.0	-25.9	Peak	Vertical
	11438.0	36.4	15.5	51.9	74.0	-22.1	Peak	Vertical
*	13087.0	36.7	14.8	51.5	68.2	-16.7	Peak	Vertical
*	17150.0	38.3	18.4	56.7	68.2	-11.5	Peak	Vertical

Note 1: "*" is not in restricted band, its limit is -27dBm/MHz. At a distance of 3 meters, the field strength limit in dB μ V/m can be determined by adding a "conversion" factor of 95.2dB to the EIRP limit of -27dBm/MHz to obtain the limit for out of band spurious emissions.

Note 2: Measure Level (dB μ V/m) = Reading Level (dB μ V) + Factor (dB)

Factor (dB) = Cable Loss (dB) + Antenna Factor (dB/m) - Pre_Amplifier Gain (dB)

Test Site	WZ-AC2	Test Engineer	Buter Shi
Test Date	2021/01/02	Test Channel	149
Test Mode	802.11n-HT20 (CDD Mode)		
Remark	1. Average measurement was not performed if peak level lower than average limit. 2. Other frequency was 20dB below limit line within 1-18GHz, there is not show in the report.		

Mark	Frequency (MHz)	Reading Level (dB μ V)	Factor (dB)	Measure Level (dB μ V/m)	Limit (dB μ V/m)	Margin (dB)	Detector	Polarization
	8454.5	36.0	11.0	47.0	74.0	-27.0	Peak	Horizontal
	11497.5	36.8	15.6	52.4	74.0	-21.6	Peak	Horizontal
*	12908.5	34.4	14.7	49.1	68.2	-19.1	Peak	Horizontal
*	17235.0	43.7	18.0	61.7	68.2	-6.5	Peak	Horizontal
	8242.0	36.3	10.9	47.2	74.0	-26.8	Peak	Vertical
	11123.5	36.8	15.1	51.9	74.0	-22.1	Peak	Vertical
*	12891.5	35.8	14.7	50.5	68.2	-17.7	Peak	Vertical
*	17226.5	42.9	18.0	60.9	68.2	-7.3	Peak	Vertical

Note 1: "*" is not in restricted band, its limit is -27dBm/MHz. At a distance of 3 meters, the field strength limit in dB μ V/m can be determined by adding a "conversion" factor of 95.2dB to the EIRP limit of -27dBm/MHz to obtain the limit for out of band spurious emissions.

Note 2: Measure Level (dB μ V/m) = Reading Level (dB μ V) + Factor (dB)

Factor (dB) = Cable Loss (dB) + Antenna Factor (dB/m) - Pre_Amplifier Gain (dB)

Test Site	WZ-AC2	Test Engineer	Buter Shi
Test Date	2021/01/02	Test Channel	157
Test Mode	802.11n-HT20 (CDD Mode)		
Remark	1. Average measurement was not performed if peak level lower than average limit. 2. Other frequency was 20dB below limit line within 1-18GHz, there is not show in the report.		

Mark	Frequency (MHz)	Reading Level (dBμV)	Factor (dB)	Measure Level (dBμV/m)	Limit (dBμV/m)	Margin (dB)	Detector	Polarization
	8259.0	37.4	11.1	48.5	74.0	-25.5	Peak	Horizontal
	10885.5	36.7	15.7	52.4	74.0	-21.6	Peak	Horizontal
*	12857.5	35.0	14.8	49.8	68.2	-18.4	Peak	Horizontal
*	17345.5	45.9	18.0	63.9	68.2	-4.3	Peak	Horizontal
	8250.5	37.8	11.0	48.8	74.0	-25.2	Peak	Vertical
	11565.5	37.7	15.2	52.9	74.0	-21.1	Peak	Vertical
*	12849.0	37.3	14.6	51.9	68.2	-16.3	Peak	Vertical
*	17133.0	36.4	18.7	55.1	68.2	-13.1	Peak	Vertical

Note 1: "*" is not in restricted band, its limit is -27dBm/MHz. At a distance of 3 meters, the field strength limit in dBμV/m can be determined by adding a "conversion" factor of 95.2dB to the EIRP limit of -27dBm/MHz to obtain the limit for out of band spurious emissions.

Note 2: Measure Level (dBμV/m) = Reading Level (dBμV) + Factor (dB)

Factor (dB) = Cable Loss (dB) + Antenna Factor (dB/m) - Pre_Amplifier Gain (dB)

Test Site	WZ-AC2	Test Engineer	Buter Shi
Test Date	2021/01/02	Test Channel	165
Test Mode	802.11n-HT20 (CDD Mode)		
Remark	1. Average measurement was not performed if peak level lower than average limit. 2. Other frequency was 20dB below limit line within 1-18GHz, there is not show in the report.		

Mark	Frequency (MHz)	Reading Level (dBμV)	Factor (dB)	Measure Level (dBμV/m)	Limit (dBμV/m)	Margin (dB)	Detector	Polarization
	8191.0	38.1	10.7	48.8	74.0	-25.2	Peak	Horizontal
	11353.0	36.1	15.5	51.6	74.0	-22.4	Peak	Horizontal
*	13095.5	36.6	14.7	51.3	68.2	-16.9	Peak	Horizontal
*	17464.5	41.5	19.6	61.1	68.2	-7.1	Peak	Horizontal
	8250.5	37.6	11.0	48.6	74.0	-25.4	Peak	Vertical
	11650.5	37.1	14.9	52.0	74.0	-22.0	Peak	Vertical
*	12917.0	35.1	14.7	49.8	68.2	-18.4	Peak	Vertical
*	17473.0	39.2	19.5	58.7	68.2	-9.5	Peak	Vertical

Note 1: "*" is not in restricted band, its limit is -27dBm/MHz. At a distance of 3 meters, the field strength limit in dBμV/m can be determined by adding a "conversion" factor of 95.2dB to the EIRP limit of -27dBm/MHz to obtain the limit for out of band spurious emissions.

Note 2: Measure Level (dBμV/m) = Reading Level (dBμV) + Factor (dB)

Factor (dB) = Cable Loss (dB) + Antenna Factor (dB/m) - Pre_Amplifier Gain (dB)

Test Site	WZ-AC2	Test Engineer	Buter Shi
Test Date	2021/01/02	Test Channel	38
Test Mode	802.11n-HT40 (CDD Mode)		
Remark	1. Average measurement was not performed if peak level lower than average limit. 2. Other frequency was 20dB below limit line within 1-18GHz, there is not show in the report.		

Mark	Frequency (MHz)	Reading Level (dBμV)	Factor (dB)	Measure Level (dBμV/m)	Limit (dBμV/m)	Margin (dB)	Detector	Polarization
*	8735.0	35.6	11.9	47.5	68.2	-20.7	Peak	Horizontal
*	10375.5	39.3	14.5	53.8	68.2	-14.4	Peak	Horizontal
	11489.0	36.0	15.6	51.6	74.0	-22.4	Peak	Horizontal
	15552.0	43.9	14.8	58.7	74.0	-15.3	Peak	Horizontal
	15552.0	33.6	14.8	48.4	54.0	-5.6	Average	Horizontal
*	8828.5	36.8	12.0	48.8	68.2	-19.4	Peak	Vertical
*	9806.0	35.6	14.3	49.9	68.2	-18.3	Peak	Vertical
	11234.0	36.8	15.2	52.0	74.0	-22.0	Peak	Vertical
	15560.5	39.8	15.0	54.8	74.0	-19.2	Peak	Vertical
	15560.5	30.3	15.0	45.3	54.0	-8.7	Average	Vertical

Note 1: "*" is not in restricted band, its limit is -27dBm/MHz. At a distance of 3 meters, the field strength limit in dBμV/m can be determined by adding a "conversion" factor of 95.2dB to the EIRP limit of -27dBm/MHz to obtain the limit for out of band spurious emissions.

Note 2: Measure Level (dBμV/m) = Reading Level (dBμV) + Factor (dB)

Factor (dB) = Cable Loss (dB) + Antenna Factor (dB/m) - Pre_Amplifier Gain (dB)

Test Site	WZ-AC2	Test Engineer	Buter Shi
Test Date	2021/01/02	Test Channel	46
Test Mode	802.11n-HT40 (CDD Mode)		
Remark	1. Average measurement was not performed if peak level lower than average limit. 2. Other frequency was 20dB below limit line within 1-18GHz, there is not show in the report.		

Mark	Frequency (MHz)	Reading Level (dB μ V)	Factor (dB)	Measure Level (dB μ V/m)	Limit (dB μ V/m)	Margin (dB)	Detector	Polarization
*	8701.0	36.6	12.0	48.6	68.2	-19.6	Peak	Horizontal
*	10452.0	38.8	14.4	53.2	68.2	-15.0	Peak	Horizontal
	11863.0	37.1	14.9	52.0	74.0	-22.0	Peak	Horizontal
	15688.0	46.0	15.0	61.0	74.0	-13.0	Peak	Horizontal
	15688.0	31.4	15.0	46.4	54.0	-7.6	Average	Horizontal
*	8769.0	35.2	11.9	47.1	68.2	-21.1	Peak	Vertical
*	10469.0	36.9	15.1	52.0	68.2	-16.2	Peak	Vertical
	11098.0	36.7	15.3	52.0	74.0	-22.0	Peak	Vertical
	15705.0	41.0	14.9	55.9	74.0	-18.1	Peak	Vertical
	15705.0	30.1	14.9	45.0	54.0	-9.0	Average	Vertical

Note 1: "*" is not in restricted band, its limit is -27dBm/MHz. At a distance of 3 meters, the field strength limit in dB μ V/m can be determined by adding a "conversion" factor of 95.2dB to the EIRP limit of -27dBm/MHz to obtain the limit for out of band spurious emissions.

Note 2: Measure Level (dB μ V/m) = Reading Level (dB μ V) + Factor (dB)

Factor (dB) = Cable Loss (dB) + Antenna Factor (dB/m) - Pre_Amplifier Gain (dB)

Test Site	WZ-AC2	Test Engineer	Buter Shi
Test Date	2021/01/02	Test Channel	54
Test Mode	802.11n-HT40 (CDD Mode)		
Remark	1. Average measurement was not performed if peak level lower than average limit. 2. Other frequency was 20dB below limit line within 1-18GHz, there is not show in the report.		

Mark	Frequency (MHz)	Reading Level (dBμV)	Factor (dB)	Measure Level (dBμV/m)	Limit (dBμV/m)	Margin (dB)	Detector	Polarization
*	8743.5	36.0	11.9	47.9	68.2	-20.3	Peak	Horizontal
*	10545.5	37.5	15.4	52.9	68.2	-15.3	Peak	Horizontal
	11446.5	36.6	15.4	52.0	74.0	-22.0	Peak	Horizontal
	15815.5	46.0	14.7	60.7	74.0	-13.3	Peak	Horizontal
	15815.5	32.6	14.7	47.3	54.0	-6.7	Average	Horizontal
*	8709.5	34.3	11.9	46.2	68.2	-22.0	Peak	Vertical
*	10545.5	37.3	15.4	52.7	68.2	-15.5	Peak	Vertical
	11489.0	36.3	15.6	51.9	74.0	-22.1	Peak	Vertical
	15594.5	35.2	15.3	50.5	74.0	-23.5	Peak	Vertical

Note 1: "*" is not in restricted band, its limit is -27dBm/MHz. At a distance of 3 meters, the field strength limit in dBμV/m can be determined by adding a "conversion" factor of 95.2dB to the EIRP limit of -27dBm/MHz to obtain the limit for out of band spurious emissions.

Note 2: Measure Level (dBμV/m) = Reading Level (dBμV) + Factor (dB)

Factor (dB) = Cable Loss (dB) + Antenna Factor (dB/m) - Pre_Amplifier Gain (dB)

Test Site	WZ-AC2	Test Engineer	Buter Shi
Test Date	2021/01/02	Test Channel	62
Test Mode	802.11n-HT40 (CDD Mode)		
Remark	1. Average measurement was not performed if peak level lower than average limit. 2. Other frequency was 20dB below limit line within 1-18GHz, there is not show in the report.		

Mark	Frequency (MHz)	Reading Level (dB μ V)	Factor (dB)	Measure Level (dB μ V/m)	Limit (dB μ V/m)	Margin (dB)	Detector	Polarization
*	8828.5	37.4	12.0	49.4	68.2	-18.8	Peak	Horizontal
*	10188.5	36.1	14.8	50.9	68.2	-17.3	Peak	Horizontal
	11676.0	36.5	15.3	51.8	74.0	-22.2	Peak	Horizontal
	15909.0	47.9	14.5	62.4	74.0	-11.6	Peak	Horizontal
	15909.0	34.3	14.5	48.8	54.0	-5.2	Average	Horizontal
*	8862.5	36.5	11.8	48.3	68.2	-19.9	Peak	Vertical
*	10401.0	36.3	15.0	51.3	68.2	-16.9	Peak	Vertical
	11625.0	36.9	15.0	51.9	74.0	-22.1	Peak	Vertical
	15909.0	41.2	14.5	55.7	74.0	-18.3	Peak	Vertical
	15909.0	30.6	14.5	45.1	54.0	-8.9	Average	Vertical

Note 1: "*" is not in restricted band, its limit is -27dBm/MHz. At a distance of 3 meters, the field strength limit in dB μ V/m can be determined by adding a "conversion" factor of 95.2dB to the EIRP limit of -27dBm/MHz to obtain the limit for out of band spurious emissions.

Note 2: Measure Level (dB μ V/m) = Reading Level (dB μ V) + Factor (dB)

Factor (dB) = Cable Loss (dB) + Antenna Factor (dB/m) - Pre_Amplifier Gain (dB)

Test Site	WZ-AC2	Test Engineer	Buter Shi
Test Date	2021/01/02	Test Channel	102
Test Mode	802.11n-HT40 (CDD Mode)		
Remark	1. Average measurement was not performed if peak level lower than average limit. 2. Other frequency was 20dB below limit line within 1-18GHz, there is not show in the report.		

Mark	Frequency (MHz)	Reading Level (dBμV)	Factor (dB)	Measure Level (dBμV/m)	Limit (dBμV/m)	Margin (dB)	Detector	Polarization
	8471.5	37.5	11.0	48.5	74.0	-25.5	Peak	Horizontal
	10996.0	35.9	15.7	51.6	74.0	-22.4	Peak	Horizontal
*	13061.5	36.6	14.8	51.4	68.2	-16.8	Peak	Horizontal
*	16529.5	44.2	16.1	60.3	68.2	-7.9	Peak	Horizontal
	8276.0	36.5	10.6	47.1	74.0	-26.9	Peak	Vertical
	11098.0	36.1	15.3	51.4	74.0	-22.6	Peak	Vertical
*	12866.0	36.1	14.8	50.9	68.2	-17.3	Peak	Vertical
*	16691.0	37.8	17.6	55.4	68.2	-12.8	Peak	Vertical

Note 1: "*" is not in restricted band, its limit is -27dBm/MHz. At a distance of 3 meters, the field strength limit in dBμV/m can be determined by adding a "conversion" factor of 95.2dB to the EIRP limit of -27dBm/MHz to obtain the limit for out of band spurious emissions.

Note 2: Measure Level (dBμV/m) = Reading Level (dBμV) + Factor (dB)

Factor (dB) = Cable Loss (dB) + Antenna Factor (dB/m) - Pre_Amplifier Gain (dB)

Test Site	WZ-AC2	Test Engineer	Buter Shi
Test Date	2021/01/02	Test Channel	110
Test Mode	802.11n-HT40 (CDD Mode)		
Remark	1. Average measurement was not performed if peak level lower than average limit. 2. Other frequency was 20dB below limit line within 1-18GHz, there is not show in the report.		

Mark	Frequency (MHz)	Reading Level (dBμV)	Factor (dB)	Measure Level (dBμV/m)	Limit (dBμV/m)	Margin (dB)	Detector	Polarization
	8310.0	35.8	11.0	46.8	74.0	-27.2	Peak	Horizontal
	11098.0	37.3	15.3	52.6	74.0	-21.4	Peak	Horizontal
*	13070.0	35.9	14.8	50.7	68.2	-17.5	Peak	Horizontal
*	16631.5	46.3	16.8	63.1	68.2	-5.1	Peak	Horizontal
	8199.5	36.8	10.8	47.6	74.0	-26.4	Peak	Vertical
	11506.0	37.1	15.3	52.4	74.0	-21.6	Peak	Vertical
*	13053.0	35.0	14.8	49.8	68.2	-18.4	Peak	Vertical
*	16640.0	38.5	16.9	55.4	68.2	-12.8	Peak	Vertical

Note 1: "*" is not in restricted band, its limit is -27dBm/MHz. At a distance of 3 meters, the field strength limit in dBμV/m can be determined by adding a "conversion" factor of 95.2dB to the EIRP limit of -27dBm/MHz to obtain the limit for out of band spurious emissions.

Note 2: Measure Level (dBμV/m) = Reading Level (dBμV) + Factor (dB)

Factor (dB) = Cable Loss (dB) + Antenna Factor (dB/m) - Pre_Amplifier Gain (dB)

Test Site	WZ-AC2	Test Engineer	Buter Shi
Test Date	2021/01/02	Test Channel	134
Test Mode	802.11n-HT40 (CDD Mode)		
Remark	1. Average measurement was not performed if peak level lower than average limit. 2. Other frequency was 20dB below limit line within 1-18GHz, there is not show in the report.		

Mark	Frequency (MHz)	Reading Level (dB μ V)	Factor (dB)	Measure Level (dB μ V/m)	Limit (dB μ V/m)	Margin (dB)	Detector	Polarization
	8216.5	36.9	11.0	47.9	74.0	-26.1	Peak	Horizontal
	11336.0	37.9	15.3	53.2	74.0	-20.8	Peak	Horizontal
*	12874.5	35.6	14.8	50.4	68.2	-17.8	Peak	Horizontal
*	17014.0	46.1	18.4	64.5	68.2	-3.7	Peak	Horizontal
	8318.5	37.6	10.8	48.4	74.0	-25.6	Peak	Vertical
	11276.5	36.2	15.1	51.3	74.0	-22.7	Peak	Vertical
*	13002.0	36.5	14.8	51.3	68.2	-16.9	Peak	Vertical
*	17014.0	38.1	18.4	56.5	68.2	-11.7	Peak	Vertical

Note 1: "*" is not in restricted band, its limit is -27dBm/MHz. At a distance of 3 meters, the field strength limit in dB μ V/m can be determined by adding a "conversion" factor of 95.2dB to the EIRP limit of -27dBm/MHz to obtain the limit for out of band spurious emissions.

Note 2: Measure Level (dB μ V/m) = Reading Level (dB μ V) + Factor (dB)

Factor (dB) = Cable Loss (dB) + Antenna Factor (dB/m) - Pre_Amplifier Gain (dB)

Test Site	WZ-AC2	Test Engineer	Buter Shi
Test Date	2021/01/02	Test Channel	142
Test Mode	802.11n-HT40 (CDD Mode)		
Remark	1. Average measurement was not performed if peak level lower than average limit. 2. Other frequency was 20dB below limit line within 1-18GHz, there is not show in the report.		

Mark	Frequency (MHz)	Reading Level (dBμV)	Factor (dB)	Measure Level (dBμV/m)	Limit (dBμV/m)	Margin (dB)	Detector	Polarization
	8310.0	35.8	11.0	46.8	74.0	-27.2	Peak	Horizontal
	11421.0	38.3	15.2	53.5	74.0	-20.5	Peak	Horizontal
*	13223.0	36.3	14.9	51.2	68.2	-17.0	Peak	Horizontal
*	17107.5	45.4	18.7	64.1	68.2	-4.1	Peak	Horizontal
	8310.0	37.1	11.0	48.1	74.0	-25.9	Peak	Vertical
	11523.0	36.3	15.3	51.6	74.0	-22.4	Peak	Vertical
*	13044.5	36.4	14.8	51.2	68.2	-17.0	Peak	Vertical
*	17133.0	39.5	18.7	58.2	68.2	-10.0	Peak	Vertical

Note 1: "*" is not in restricted band, its limit is -27dBm/MHz. At a distance of 3 meters, the field strength limit in dBμV/m can be determined by adding a "conversion" factor of 95.2dB to the EIRP limit of -27dBm/MHz to obtain the limit for out of band spurious emissions.

Note 2: Measure Level (dBμV/m) = Reading Level (dBμV) + Factor (dB)

Factor (dB) = Cable Loss (dB) + Antenna Factor (dB/m) - Pre_Amplifier Gain (dB)

Test Site	WZ-AC2	Test Engineer	Buter Shi
Test Date	2021/01/02	Test Channel	151
Test Mode	802.11n-HT40 (CDD Mode)		
Remark	1. Average measurement was not performed if peak level lower than average limit. 2. Other frequency was 20dB below limit line within 1-18GHz, there is not show in the report.		

Mark	Frequency (MHz)	Reading Level (dB μ V)	Factor (dB)	Measure Level (dB μ V/m)	Limit (dB μ V/m)	Margin (dB)	Detector	Polarization
	8225.0	37.7	11.1	48.8	74.0	-25.2	Peak	Horizontal
	11514.5	36.8	15.2	52.0	74.0	-22.0	Peak	Horizontal
*	13027.5	34.4	14.9	49.3	68.2	-18.9	Peak	Horizontal
*	17260.5	42.2	17.5	59.7	68.2	-8.5	Peak	Horizontal
	8310.0	37.5	11.0	48.5	74.0	-25.5	Peak	Vertical
	12058.5	36.6	14.7	51.3	74.0	-22.7	Peak	Vertical
*	13112.5	34.9	14.8	49.7	68.2	-18.5	Peak	Vertical
*	17269.0	38.9	17.6	56.5	68.2	-11.7	Peak	Vertical

Note 1: "*" is not in restricted band, its limit is -27dBm/MHz. At a distance of 3 meters, the field strength limit in dB μ V/m can be determined by adding a "conversion" factor of 95.2dB to the EIRP limit of -27dBm/MHz to obtain the limit for out of band spurious emissions.

Note 2: Measure Level (dB μ V/m) = Reading Level (dB μ V) + Factor (dB)

Factor (dB) = Cable Loss (dB) + Antenna Factor (dB/m) - Pre_Amplifier Gain (dB)

Test Site	WZ-AC2	Test Engineer	Buter Shi
Test Date	2021/01/02	Test Channel	159
Test Mode	802.11n-HT40 (CDD Mode)		
Remark	1. Average measurement was not performed if peak level lower than average limit. 2. Other frequency was 20dB below limit line within 1-18GHz, there is not show in the report.		

Mark	Frequency (MHz)	Reading Level (dB μ V)	Factor (dB)	Measure Level (dB μ V/m)	Limit (dB μ V/m)	Margin (dB)	Detector	Polarization
	8165.5	37.7	11.1	48.8	74.0	-25.2	Peak	Horizontal
	11591.0	37.7	15.2	52.9	74.0	-21.1	Peak	Horizontal
*	13010.5	35.6	14.8	50.4	68.2	-17.8	Peak	Horizontal
*	17388.0	46.2	19.2	65.4	68.2	-2.8	Peak	Horizontal
	8284.5	36.0	10.7	46.7	74.0	-27.3	Peak	Vertical
	11021.5	36.9	15.4	52.3	74.0	-21.7	Peak	Vertical
*	13010.5	35.0	14.8	49.8	68.2	-18.4	Peak	Vertical
*	17388.0	37.9	19.2	57.1	68.2	-11.1	Peak	Vertical

Note 1: "*" is not in restricted band, its limit is -27dBm/MHz. At a distance of 3 meters, the field strength limit in dB μ V/m can be determined by adding a "conversion" factor of 95.2dB to the EIRP limit of -27dBm/MHz to obtain the limit for out of band spurious emissions.

Note 2: Measure Level (dB μ V/m) = Reading Level (dB μ V) + Factor (dB)

Factor (dB) = Cable Loss (dB) + Antenna Factor (dB/m) - Pre_Amplifier Gain (dB)

Test Site	WZ-AC2	Test Engineer	Buter Shi
Test Date	2021/01/02	Test Channel	36
Test Mode	802.11ac-VHT20 (CDD Mode)		
Remark	1. Average measurement was not performed if peak level lower than average limit. 2. Other frequency was 20dB below limit line within 1-18GHz, there is not show in the report.		

Mark	Frequency (MHz)	Reading Level (dBμV)	Factor (dB)	Measure Level (dBμV/m)	Limit (dBμV/m)	Margin (dB)	Detector	Polarization
*	8828.5	35.3	12.0	47.3	68.2	-20.9	Peak	Horizontal
*	10316.0	35.3	14.7	50.0	68.2	-18.2	Peak	Horizontal
	11489.0	35.8	15.6	51.4	74.0	-22.6	Peak	Horizontal
	15569.0	35.6	15.3	50.9	74.0	-23.1	Peak	Horizontal
*	8718.0	36.1	11.9	48.0	68.2	-20.2	Peak	Vertical
*	10307.5	35.1	14.5	49.6	68.2	-18.6	Peak	Vertical
	11489.0	36.1	15.6	51.7	74.0	-22.3	Peak	Vertical
	15841.0	35.2	14.4	49.6	74.0	-24.4	Peak	Vertical

Note 1: "*" is not in restricted band, its limit is -27dBm/MHz. At a distance of 3 meters, the field strength limit in dBμV/m can be determined by adding a "conversion" factor of 95.2dB to the EIRP limit of -27dBm/MHz to obtain the limit for out of band spurious emissions.

Note 2: Measure Level (dBμV/m) = Reading Level (dBμV) + Factor (dB)

Factor (dB) = Cable Loss (dB) + Antenna Factor (dB/m) - Pre_Amplifier Gain (dB)

Test Site	WZ-AC2	Test Engineer	Buter Shi
Test Date	2021/01/02	Test Channel	44
Test Mode	802.11ac-VHT20 (CDD Mode)		
Remark	1. Average measurement was not performed if peak level lower than average limit. 2. Other frequency was 20dB below limit line within 1-18GHz, there is not show in the report.		

Mark	Frequency (MHz)	Reading Level (dBμV)	Factor (dB)	Measure Level (dBμV/m)	Limit (dBμV/m)	Margin (dB)	Detector	Polarization
*	8752.0	35.4	12.0	47.4	68.2	-20.8	Peak	Horizontal
*	10129.0	34.4	14.8	49.2	68.2	-19.0	Peak	Horizontal
	11531.5	36.1	15.3	51.4	74.0	-22.6	Peak	Horizontal
	15832.5	34.9	14.5	49.4	74.0	-24.6	Peak	Horizontal
*	8760.5	35.8	12.0	47.8	68.2	-20.4	Peak	Vertical
*	9755.0	35.1	14.5	49.6	68.2	-18.6	Peak	Vertical
	11370.0	35.8	15.4	51.2	74.0	-22.8	Peak	Vertical
	15492.5	34.9	15.1	50.0	74.0	-24.0	Peak	Vertical

Note 1: "*" is not in restricted band, its limit is -27dBm/MHz. At a distance of 3 meters, the field strength limit in dBμV/m can be determined by adding a "conversion" factor of 95.2dB to the EIRP limit of -27dBm/MHz to obtain the limit for out of band spurious emissions.

Note 2: Measure Level (dBμV/m) = Reading Level (dBμV) + Factor (dB)

Factor (dB) = Cable Loss (dB) + Antenna Factor (dB/m) - Pre_Amplifier Gain (dB)

Test Site	WZ-AC2	Test Engineer	Buter Shi
Test Date	2021/01/02	Test Channel	48
Test Mode	802.11ac-VHT20 (CDD Mode)		
Remark	1. Average measurement was not performed if peak level lower than average limit. 2. Other frequency was 20dB below limit line within 1-18GHz, there is not show in the report.		

Mark	Frequency (MHz)	Reading Level (dBμV)	Factor (dB)	Measure Level (dBμV/m)	Limit (dBμV/m)	Margin (dB)	Detector	Polarization
*	8820.0	37.1	12.3	49.4	68.2	-18.8	Peak	Horizontal
*	9984.5	35.5	14.3	49.8	68.2	-18.4	Peak	Horizontal
	11557.0	36.0	15.2	51.2	74.0	-22.8	Peak	Horizontal
	15603.0	34.5	15.0	49.5	74.0	-24.5	Peak	Horizontal
*	8769.0	36.3	11.9	48.2	68.2	-20.0	Peak	Vertical
*	10197.0	35.8	14.8	50.6	68.2	-17.6	Peak	Vertical
	11693.0	36.8	15.3	52.1	74.0	-21.9	Peak	Vertical
	15705.0	35.0	14.9	49.9	74.0	-24.1	Peak	Vertical

Note 1: "*" is not in restricted band, its limit is -27dBm/MHz. At a distance of 3 meters, the field strength limit in dBμV/m can be determined by adding a "conversion" factor of 95.2dB to the EIRP limit of -27dBm/MHz to obtain the limit for out of band spurious emissions.

Note 2: Measure Level (dBμV/m) = Reading Level (dBμV) + Factor (dB)

Factor (dB) = Cable Loss (dB) + Antenna Factor (dB/m) - Pre_Amplifier Gain (dB)

Test Site	WZ-AC2	Test Engineer	Buter Shi
Test Date	2021/01/02	Test Channel	52
Test Mode	802.11ac-VHT20 (CDD Mode)		
Remark	1. Average measurement was not performed if peak level lower than average limit. 2. Other frequency was 20dB below limit line within 1-18GHz, there is not show in the report.		

Mark	Frequency (MHz)	Reading Level (dBμV)	Factor (dB)	Measure Level (dBμV/m)	Limit (dBμV/m)	Margin (dB)	Detector	Polarization
*	8786.0	36.4	11.8	48.2	68.2	-20.0	Peak	Horizontal
*	10171.5	34.6	14.5	49.1	68.2	-19.1	Peak	Horizontal
	11115.0	36.7	15.1	51.8	74.0	-22.2	Peak	Horizontal
	15577.5	35.6	15.4	51.0	74.0	-23.0	Peak	Horizontal
*	8667.0	36.0	11.6	47.6	68.2	-20.6	Peak	Vertical
*	9806.0	35.0	14.3	49.3	68.2	-18.9	Peak	Vertical
	11761.0	36.1	15.0	51.1	74.0	-22.9	Peak	Vertical
	15441.5	37.3	15.6	52.9	74.0	-21.1	Peak	Vertical

Note 1: "*" is not in restricted band, its limit is -27dBm/MHz. At a distance of 3 meters, the field strength limit in dBμV/m can be determined by adding a "conversion" factor of 95.2dB to the EIRP limit of -27dBm/MHz to obtain the limit for out of band spurious emissions.

Note 2: Measure Level (dBμV/m) = Reading Level (dBμV) + Factor (dB)

Factor (dB) = Cable Loss (dB) + Antenna Factor (dB/m) - Pre_Amplifier Gain (dB)

Test Site	WZ-AC2	Test Engineer	Buter Shi
Test Date	2021/01/02	Test Channel	60
Test Mode	802.11ac-VHT20 (CDD Mode)		
Remark	1. Average measurement was not performed if peak level lower than average limit. 2. Other frequency was 20dB below limit line within 1-18GHz, there is not show in the report.		

Mark	Frequency (MHz)	Reading Level (dB μ V)	Factor (dB)	Measure Level (dB μ V/m)	Limit (dB μ V/m)	Margin (dB)	Detector	Polarization
*	8641.5	37.2	11.6	48.8	68.2	-19.4	Peak	Horizontal
*	10163.0	35.4	14.2	49.6	68.2	-18.6	Peak	Horizontal
	11489.0	36.5	15.6	52.1	74.0	-21.9	Peak	Horizontal
	15773.0	35.3	14.6	49.9	74.0	-24.1	Peak	Horizontal
*	8828.5	36.7	12.0	48.7	68.2	-19.5	Peak	Vertical
*	10120.5	35.7	14.6	50.3	68.2	-17.9	Peak	Vertical
	11497.5	36.0	15.6	51.6	74.0	-22.4	Peak	Vertical
	15611.5	35.4	14.9	50.3	74.0	-23.7	Peak	Vertical

Note 1: "*" is not in restricted band, its limit is -27dBm/MHz. At a distance of 3 meters, the field strength limit in dB μ V/m can be determined by adding a "conversion" factor of 95.2dB to the EIRP limit of -27dBm/MHz to obtain the limit for out of band spurious emissions.

Note 2: Measure Level (dB μ V/m) = Reading Level (dB μ V) + Factor (dB)

Factor (dB) = Cable Loss (dB) + Antenna Factor (dB/m) - Pre_Amplifier Gain (dB)

Test Site	WZ-AC2	Test Engineer	Buter Shi
Test Date	2021/01/02	Test Channel	64
Test Mode	802.11ac-VHT20 (CDD Mode)		
Remark	1. Average measurement was not performed if peak level lower than average limit. 2. Other frequency was 20dB below limit line within 1-18GHz, there is not show in the report.		

Mark	Frequency (MHz)	Reading Level (dBμV)	Factor (dB)	Measure Level (dBμV/m)	Limit (dBμV/m)	Margin (dB)	Detector	Polarization
*	8862.5	37.0	11.8	48.8	68.2	-19.4	Peak	Horizontal
*	9984.5	35.4	14.3	49.7	68.2	-18.5	Peak	Horizontal
	11480.5	36.3	15.5	51.8	74.0	-22.2	Peak	Horizontal
	15637.0	34.8	15.1	49.9	74.0	-24.1	Peak	Horizontal
*	7876.5	36.6	10.7	47.3	68.2	-20.9	Peak	Vertical
*	8760.5	36.6	12.0	48.6	68.2	-19.6	Peak	Vertical
	11081.0	36.2	15.5	51.7	74.0	-22.3	Peak	Vertical
	15637.0	37.0	15.1	52.1	74.0	-21.9	Peak	Vertical

Note 1: "*" is not in restricted band, its limit is -27dBm/MHz. At a distance of 3 meters, the field strength limit in dBμV/m can be determined by adding a "conversion" factor of 95.2dB to the EIRP limit of -27dBm/MHz to obtain the limit for out of band spurious emissions.

Note 2: Measure Level (dBμV/m) = Reading Level (dBμV) + Factor (dB)

Factor (dB) = Cable Loss (dB) + Antenna Factor (dB/m) - Pre_Amplifier Gain (dB)

Test Site	WZ-AC2	Test Engineer	Buter Shi
Test Date	2021/01/02	Test Channel	100
Test Mode	802.11ac-VHT20 (CDD Mode)		
Remark	1. Average measurement was not performed if peak level lower than average limit. 2. Other frequency was 20dB below limit line within 1-18GHz, there is not show in the report.		

Mark	Frequency (MHz)	Reading Level (dB μ V)	Factor (dB)	Measure Level (dB μ V/m)	Limit (dB μ V/m)	Margin (dB)	Detector	Polarization
*	8650.0	36.1	11.9	48.0	68.2	-20.2	Peak	Horizontal
*	10188.5	35.0	14.8	49.8	68.2	-18.4	Peak	Horizontal
	11429.5	36.4	15.3	51.7	74.0	-22.3	Peak	Horizontal
	15560.5	34.9	15.0	49.9	74.0	-24.1	Peak	Horizontal
*	8854.0	36.1	11.7	47.8	68.2	-20.4	Peak	Vertical
*	10180.0	35.7	14.8	50.5	68.2	-17.7	Peak	Vertical
	11531.5	37.0	15.3	52.3	74.0	-21.7	Peak	Vertical
	15815.5	36.8	14.7	51.5	74.0	-22.5	Peak	Vertical

Note 1: "*" is not in restricted band, its limit is -27dBm/MHz. At a distance of 3 meters, the field strength limit in dB μ V/m can be determined by adding a "conversion" factor of 95.2dB to the EIRP limit of -27dBm/MHz to obtain the limit for out of band spurious emissions.

Note 2: Measure Level (dB μ V/m) = Reading Level (dB μ V) + Factor (dB)

Factor (dB) = Cable Loss (dB) + Antenna Factor (dB/m) - Pre_Amplifier Gain (dB)

Test Site	WZ-AC2	Test Engineer	Buter Shi
Test Date	2021/01/02	Test Channel	116
Test Mode	802.11ac-VHT20 (CDD Mode)		
Remark	1. Average measurement was not performed if peak level lower than average limit. 2. Other frequency was 20dB below limit line within 1-18GHz, there is not show in the report.		

Mark	Frequency (MHz)	Reading Level (dB μ V)	Factor (dB)	Measure Level (dB μ V/m)	Limit (dB μ V/m)	Margin (dB)	Detector	Polarization
*	8837.0	36.8	11.8	48.6	68.2	-19.6	Peak	Horizontal
*	10265.0	35.2	14.6	49.8	68.2	-18.4	Peak	Horizontal
	11531.5	36.3	15.3	51.6	74.0	-22.4	Peak	Horizontal
	15662.5	36.9	15.0	51.9	74.0	-22.1	Peak	Horizontal
*	8777.5	34.7	11.8	46.5	68.2	-21.7	Peak	Vertical
*	10035.5	33.8	14.5	48.3	68.2	-19.9	Peak	Vertical
	11956.5	35.3	14.8	50.1	74.0	-23.9	Peak	Vertical
	15611.5	34.6	14.9	49.5	74.0	-24.5	Peak	Vertical

Note 1: "*" is not in restricted band, its limit is -27dBm/MHz. At a distance of 3 meters, the field strength limit in dB μ V/m can be determined by adding a "conversion" factor of 95.2dB to the EIRP limit of -27dBm/MHz to obtain the limit for out of band spurious emissions.

Note 2: Measure Level (dB μ V/m) = Reading Level (dB μ V) + Factor (dB)

Factor (dB) = Cable Loss (dB) + Antenna Factor (dB/m) - Pre_Amplifier Gain (dB)

Test Site	WZ-AC2	Test Engineer	Buter Shi
Test Date	2021/01/02	Test Channel	140
Test Mode	802.11ac-VHT20 (CDD Mode)		
Remark	1. Average measurement was not performed if peak level lower than average limit. 2. Other frequency was 20dB below limit line within 1-18GHz, there is not show in the report.		

Mark	Frequency (MHz)	Reading Level (dB μ V)	Factor (dB)	Measure Level (dB μ V/m)	Limit (dB μ V/m)	Margin (dB)	Detector	Polarization
*	8735.0	34.8	11.9	46.7	68.2	-21.5	Peak	Horizontal
*	9772.0	34.4	14.2	48.6	68.2	-19.6	Peak	Horizontal
	11106.5	36.1	15.2	51.3	74.0	-22.7	Peak	Horizontal
	15645.5	34.5	15.2	49.7	74.0	-24.3	Peak	Horizontal
*	8905.0	36.5	12.2	48.7	68.2	-19.5	Peak	Vertical
*	10520.0	36.2	15.2	51.4	68.2	-16.8	Peak	Vertical
	11880.0	36.5	14.9	51.4	74.0	-22.6	Peak	Vertical
	15569.0	35.4	15.3	50.7	74.0	-23.3	Peak	Vertical

Note 1: "*" is not in restricted band, its limit is -27dBm/MHz. At a distance of 3 meters, the field strength limit in dB μ V/m can be determined by adding a "conversion" factor of 95.2dB to the EIRP limit of -27dBm/MHz to obtain the limit for out of band spurious emissions.

Note 2: Measure Level (dB μ V/m) = Reading Level (dB μ V) + Factor (dB)

Factor (dB) = Cable Loss (dB) + Antenna Factor (dB/m) - Pre_Amplifier Gain (dB)

Test Site	WZ-AC2	Test Engineer	Buter Shi
Test Date	2021/01/02	Test Channel	144
Test Mode	802.11ac-VHT20 (CDD Mode)		
Remark	1. Average measurement was not performed if peak level lower than average limit. 2. Other frequency was 20dB below limit line within 1-18GHz, there is not show in the report.		

Mark	Frequency (MHz)	Reading Level (dBμV)	Factor (dB)	Measure Level (dBμV/m)	Limit (dBμV/m)	Margin (dB)	Detector	Polarization
*	8905.0	37.0	12.2	49.2	68.2	-19.0	Peak	Horizontal
*	9772.0	35.0	14.2	49.2	68.2	-19.0	Peak	Horizontal
	11786.5	36.5	14.9	51.4	74.0	-22.6	Peak	Horizontal
	15450.0	36.5	15.6	52.1	74.0	-21.9	Peak	Horizontal
*	8692.5	34.7	12.1	46.8	68.2	-21.4	Peak	Vertical
*	10095.0	35.7	14.0	49.7	68.2	-18.5	Peak	Vertical
	12033.0	36.2	14.6	50.8	74.0	-23.2	Peak	Vertical
	15492.5	35.0	15.1	50.1	74.0	-23.9	Peak	Vertical

Note 1: "*" is not in restricted band, its limit is -27dBm/MHz. At a distance of 3 meters, the field strength limit in dBμV/m can be determined by adding a "conversion" factor of 95.2dB to the EIRP limit of -27dBm/MHz to obtain the limit for out of band spurious emissions.

Note 2: Measure Level (dBμV/m) = Reading Level (dBμV) + Factor (dB)

Factor (dB) = Cable Loss (dB) + Antenna Factor (dB/m) - Pre_Amplifier Gain (dB)

Test Site	WZ-AC2	Test Engineer	Buter Shi
Test Date	2021/01/02	Test Channel	149
Test Mode	802.11ac-VHT20 (CDD Mode)		
Remark	1. Average measurement was not performed if peak level lower than average limit. 2. Other frequency was 20dB below limit line within 1-18GHz, there is not show in the report.		

Mark	Frequency (MHz)	Reading Level (dB μ V)	Factor (dB)	Measure Level (dB μ V/m)	Limit (dB μ V/m)	Margin (dB)	Detector	Polarization
*	8726.5	36.4	11.9	48.3	68.2	-19.9	Peak	Horizontal
*	10120.5	35.3	14.6	49.9	68.2	-18.3	Peak	Horizontal
	11667.5	36.5	15.1	51.6	74.0	-22.4	Peak	Horizontal
	15705.0	35.6	14.9	50.5	74.0	-23.5	Peak	Horizontal
*	8684.0	35.7	11.9	47.6	68.2	-20.6	Peak	Vertical
*	10486.0	35.4	15.4	50.8	68.2	-17.4	Peak	Vertical
	11506.0	36.7	15.3	52.0	74.0	-22.0	Peak	Vertical
	15705.0	36.9	14.9	51.8	74.0	-22.2	Peak	Vertical

Note 1: "*" is not in restricted band, its limit is -27dBm/MHz. At a distance of 3 meters, the field strength limit in dB μ V/m can be determined by adding a "conversion" factor of 95.2dB to the EIRP limit of -27dBm/MHz to obtain the limit for out of band spurious emissions.

Note 2: Measure Level (dB μ V/m) = Reading Level (dB μ V) + Factor (dB)

Factor (dB) = Cable Loss (dB) + Antenna Factor (dB/m) - Pre_Amplifier Gain (dB)

Test Site	WZ-AC2	Test Engineer	Buter Shi
Test Date	2021/01/02	Test Channel	157
Test Mode	802.11ac-VHT20 (CDD Mode)		
Remark	1. Average measurement was not performed if peak level lower than average limit. 2. Other frequency was 20dB below limit line within 1-18GHz, there is not show in the report.		

Mark	Frequency (MHz)	Reading Level (dBμV)	Factor (dB)	Measure Level (dBμV/m)	Limit (dBμV/m)	Margin (dB)	Detector	Polarization
*	8658.5	35.9	11.9	47.8	68.2	-20.4	Peak	Horizontal
*	10486.0	34.7	15.4	50.1	68.2	-18.1	Peak	Horizontal
	12271.0	37.1	14.7	51.8	74.0	-22.2	Peak	Horizontal
	15467.0	37.0	15.3	52.3	74.0	-21.7	Peak	Horizontal
*	8811.5	35.5	12.3	47.8	68.2	-20.4	Peak	Vertical
*	10129.0	34.7	14.8	49.5	68.2	-18.7	Peak	Vertical
	11693.0	35.6	15.3	50.9	74.0	-23.1	Peak	Vertical
	15492.5	34.3	15.1	49.4	74.0	-24.6	Peak	Vertical

Note 1: "*" is not in restricted band, its limit is -27dBm/MHz. At a distance of 3 meters, the field strength limit in dBμV/m can be determined by adding a "conversion" factor of 95.2dB to the EIRP limit of -27dBm/MHz to obtain the limit for out of band spurious emissions.

Note 2: Measure Level (dBμV/m) = Reading Level (dBμV) + Factor (dB)

Factor (dB) = Cable Loss (dB) + Antenna Factor (dB/m) - Pre_Amplifier Gain (dB)

Test Site	WZ-AC2	Test Engineer	Buter Shi
Test Date	2021/01/02	Test Channel	165
Test Mode	802.11ac-VHT20 (CDD Mode)		
Remark	1. Average measurement was not performed if peak level lower than average limit. 2. Other frequency was 20dB below limit line within 1-18GHz, there is not show in the report.		

Mark	Frequency (MHz)	Reading Level (dB μ V)	Factor (dB)	Measure Level (dB μ V/m)	Limit (dB μ V/m)	Margin (dB)	Detector	Polarization
*	8845.5	36.9	11.7	48.6	68.2	-19.6	Peak	Horizontal
*	10188.5	35.3	14.8	50.1	68.2	-18.1	Peak	Horizontal
	11599.5	36.0	15.4	51.4	74.0	-22.6	Peak	Horizontal
	15535.0	35.6	14.9	50.5	74.0	-23.5	Peak	Horizontal
*	8692.5	35.6	12.1	47.7	68.2	-20.5	Peak	Vertical
*	9814.5	36.0	14.3	50.3	68.2	-17.9	Peak	Vertical
	11684.5	36.4	15.3	51.7	74.0	-22.3	Peak	Vertical
	15730.5	38.0	14.9	52.9	74.0	-21.1	Peak	Vertical

Note 1: "*" is not in restricted band, its limit is -27dBm/MHz. At a distance of 3 meters, the field strength limit in dB μ V/m can be determined by adding a "conversion" factor of 95.2dB to the EIRP limit of -27dBm/MHz to obtain the limit for out of band spurious emissions.

Note 2: Measure Level (dB μ V/m) = Reading Level (dB μ V) + Factor (dB)

Factor (dB) = Cable Loss (dB) + Antenna Factor (dB/m) - Pre_Amplifier Gain (dB)

Test Site	WZ-AC2	Test Engineer	Buter Shi
Test Date	2021/01/02	Test Channel	38
Test Mode	802.11ac-VHT40 (CDD Mode)		
Remark	1. Average measurement was not performed if peak level lower than average limit. 2. Other frequency was 20dB below limit line within 1-18GHz, there is not show in the report.		

Mark	Frequency (MHz)	Reading Level (dBμV)	Factor (dB)	Measure Level (dBμV/m)	Limit (dBμV/m)	Margin (dB)	Detector	Polarization
*	8811.5	35.3	12.3	47.6	68.2	-20.6	Peak	Horizontal
*	10384.0	36.7	14.6	51.3	68.2	-16.9	Peak	Horizontal
	11667.5	36.7	15.1	51.8	74.0	-22.2	Peak	Horizontal
	15577.5	40.6	15.4	56.0	74.0	-18.0	Peak	Horizontal
	15577.5	30.2	15.4	45.6	54.0	-8.4	Average	Horizontal
*	8777.5	35.8	11.8	47.6	68.2	-20.6	Peak	Vertical
*	9806.0	36.9	14.3	51.2	68.2	-17.0	Peak	Vertical
	11047.0	36.3	15.4	51.7	74.0	-22.3	Peak	Vertical
	15569.0	38.4	15.3	53.7	74.0	-20.3	Peak	Vertical

Note 1: "*" is not in restricted band, its limit is -27dBm/MHz. At a distance of 3 meters, the field strength limit in dBμV/m can be determined by adding a "conversion" factor of 95.2dB to the EIRP limit of -27dBm/MHz to obtain the limit for out of band spurious emissions.

Note 2: Measure Level (dBμV/m) = Reading Level (dBμV) + Factor (dB)

Factor (dB) = Cable Loss (dB) + Antenna Factor (dB/m) - Pre_Amplifier Gain (dB)

Test Site	WZ-AC2	Test Engineer	Buter Shi
Test Date	2021/01/02	Test Channel	46
Test Mode	802.11ac-VHT40 (CDD Mode)		
Remark	1. Average measurement was not performed if peak level lower than average limit. 2. Other frequency was 20dB below limit line within 1-18GHz, there is not show in the report.		

Mark	Frequency (MHz)	Reading Level (dBμV)	Factor (dB)	Measure Level (dBμV/m)	Limit (dBμV/m)	Margin (dB)	Detector	Polarization
*	8811.5	36.1	12.3	48.4	68.2	-19.8	Peak	Horizontal
*	9916.5	36.7	14.1	50.8	68.2	-17.4	Peak	Horizontal
	11166.0	36.0	15.1	51.1	74.0	-22.9	Peak	Horizontal
	15688.0	39.6	15.0	54.6	74.0	-19.4	Peak	Horizontal
	15688.0	29.0	15.0	44.0	54.0	-10.0	Average	Horizontal
*	8735.0	35.2	11.9	47.1	68.2	-21.1	Peak	Vertical
*	10469.0	35.9	15.1	51.0	68.2	-17.2	Peak	Vertical
	11786.5	36.5	14.9	51.4	74.0	-22.6	Peak	Vertical
	15815.5	37.2	14.7	51.9	74.0	-22.1	Peak	Vertical

Note 1: "*" is not in restricted band, its limit is -27dBm/MHz. At a distance of 3 meters, the field strength limit in dBμV/m can be determined by adding a "conversion" factor of 95.2dB to the EIRP limit of -27dBm/MHz to obtain the limit for out of band spurious emissions.

Note 2: Measure Level (dBμV/m) = Reading Level (dBμV) + Factor (dB)

Factor (dB) = Cable Loss (dB) + Antenna Factor (dB/m) - Pre_Amplifier Gain (dB)

Test Site	WZ-AC2	Test Engineer	Buter Shi
Test Date	2021/01/02	Test Channel	54
Test Mode	802.11ac-VHT40 (CDD Mode)		
Remark	1. Average measurement was not performed if peak level lower than average limit. 2. Other frequency was 20dB below limit line within 1-18GHz, there is not show in the report.		

Mark	Frequency (MHz)	Reading Level (dBμV)	Factor (dB)	Measure Level (dBμV/m)	Limit (dBμV/m)	Margin (dB)	Detector	Polarization
*	8769.0	35.6	11.9	47.5	68.2	-20.7	Peak	Horizontal
*	10554.0	35.7	15.3	51.0	68.2	-17.2	Peak	Horizontal
	12058.5	36.8	14.7	51.5	74.0	-22.5	Peak	Horizontal
	15798.5	41.7	14.8	56.5	74.0	-17.5	Peak	Horizontal
	15798.5	30.2	14.8	45.0	54.0	-9.0	Average	Horizontal
*	8905.0	37.2	12.2	49.4	68.2	-18.8	Peak	Vertical
*	10180.0	35.1	14.8	49.9	68.2	-18.3	Peak	Vertical
	11761.0	36.8	15.0	51.8	74.0	-22.2	Peak	Vertical
	15688.0	36.4	15.0	51.4	74.0	-22.6	Peak	Vertical

Note 1: "*" is not in restricted band, its limit is -27dBm/MHz. At a distance of 3 meters, the field strength limit in dBμV/m can be determined by adding a "conversion" factor of 95.2dB to the EIRP limit of -27dBm/MHz to obtain the limit for out of band spurious emissions.

Note 2: Measure Level (dBμV/m) = Reading Level (dBμV) + Factor (dB)

Factor (dB) = Cable Loss (dB) + Antenna Factor (dB/m) - Pre_Amplifier Gain (dB)

Test Site	WZ-AC2	Test Engineer	Buter Shi
Test Date	2021/01/02	Test Channel	62
Test Mode	802.11ac-VHT40 (CDD Mode)		
Remark	1. Average measurement was not performed if peak level lower than average limit. 2. Other frequency was 20dB below limit line within 1-18GHz, there is not show in the report.		

Mark	Frequency (MHz)	Reading Level (dBμV)	Factor (dB)	Measure Level (dBμV/m)	Limit (dBμV/m)	Margin (dB)	Detector	Polarization
*	8820.0	36.7	12.3	49.0	68.2	-19.2	Peak	Horizontal
*	9814.5	36.3	14.3	50.6	68.2	-17.6	Peak	Horizontal
	11353.0	36.9	15.5	52.4	74.0	-21.6	Peak	Horizontal
	15900.5	42.3	14.5	56.8	74.0	-17.2	Peak	Horizontal
	15900.5	32.4	14.5	46.9	54.0	-7.1	Average	Horizontal
*	8811.5	36.0	12.3	48.3	68.2	-19.9	Peak	Vertical
*	10120.5	34.5	14.6	49.1	68.2	-19.1	Peak	Vertical
	11497.5	35.8	15.6	51.4	74.0	-22.6	Peak	Vertical
	15424.5	36.2	15.3	51.5	74.0	-22.5	Peak	Vertical

Note 1: "*" is not in restricted band, its limit is -27dBm/MHz. At a distance of 3 meters, the field strength limit in dBμV/m can be determined by adding a "conversion" factor of 95.2dB to the EIRP limit of -27dBm/MHz to obtain the limit for out of band spurious emissions.

Note 2: Measure Level (dBμV/m) = Reading Level (dBμV) + Factor (dB)

Factor (dB) = Cable Loss (dB) + Antenna Factor (dB/m) - Pre_Amplifier Gain (dB)

Test Site	WZ-AC2	Test Engineer	Buter Shi
Test Date	2021/01/02	Test Channel	102
Test Mode	802.11ac-VHT40 (CDD Mode)		
Remark	1. Average measurement was not performed if peak level lower than average limit. 2. Other frequency was 20dB below limit line within 1-18GHz, there is not show in the report.		

Mark	Frequency (MHz)	Reading Level (dBμV)	Factor (dB)	Measure Level (dBμV/m)	Limit (dBμV/m)	Margin (dB)	Detector	Polarization
	8174.0	37.7	10.9	48.6	74.0	-25.4	Peak	Horizontal
	11888.5	36.9	15.1	52.0	74.0	-22.0	Peak	Horizontal
*	13061.5	35.9	14.8	50.7	68.2	-17.5	Peak	Horizontal
*	16529.5	40.3	16.1	56.4	68.2	-11.8	Peak	Horizontal
	8369.5	37.4	10.7	48.1	74.0	-25.9	Peak	Vertical
	11072.5	34.7	15.3	50.0	74.0	-24.0	Peak	Vertical
*	13053.0	35.9	14.8	50.7	68.2	-17.5	Peak	Vertical
*	17090.5	35.8	18.9	54.7	68.2	-13.5	Peak	Vertical

Note 1: "*" is not in restricted band, its limit is -27dBm/MHz. At a distance of 3 meters, the field strength limit in dBμV/m can be determined by adding a "conversion" factor of 95.2dB to the EIRP limit of -27dBm/MHz to obtain the limit for out of band spurious emissions.

Note 2: Measure Level (dBμV/m) = Reading Level (dBμV) + Factor (dB)

Factor (dB) = Cable Loss (dB) + Antenna Factor (dB/m) - Pre_Amplifier Gain (dB)

Test Site	WZ-AC2	Test Engineer	Buter Shi
Test Date	2021/01/02	Test Channel	110
Test Mode	802.11ac-VHT40 (CDD Mode)		
Remark	1. Average measurement was not performed if peak level lower than average limit. 2. Other frequency was 20dB below limit line within 1-18GHz, there is not show in the report.		

Mark	Frequency (MHz)	Reading Level (dB μ V)	Factor (dB)	Measure Level (dB μ V/m)	Limit (dB μ V/m)	Margin (dB)	Detector	Polarization
	8165.5	37.2	11.1	48.3	74.0	-25.7	Peak	Horizontal
	11710.0	36.4	15.0	51.4	74.0	-22.6	Peak	Horizontal
*	12951.0	35.4	14.8	50.2	68.2	-18.0	Peak	Horizontal
*	16648.5	40.7	16.9	57.6	68.2	-10.6	Peak	Horizontal
	8420.5	36.8	10.9	47.7	74.0	-26.3	Peak	Vertical
	11463.5	36.4	15.4	51.8	74.0	-22.2	Peak	Vertical
*	12840.5	35.1	14.5	49.6	68.2	-18.6	Peak	Vertical
*	15152.5	36.6	16.6	53.2	68.2	-15.0	Peak	Vertical

Note 1: "*" is not in restricted band, its limit is -27dBm/MHz. At a distance of 3 meters, the field strength limit in dB μ V/m can be determined by adding a "conversion" factor of 95.2dB to the EIRP limit of -27dBm/MHz to obtain the limit for out of band spurious emissions.

Note 2: Measure Level (dB μ V/m) = Reading Level (dB μ V) + Factor (dB)

Factor (dB) = Cable Loss (dB) + Antenna Factor (dB/m) - Pre_Amplifier Gain (dB)

Test Site	WZ-AC2	Test Engineer	Buter Shi
Test Date	2021/01/02	Test Channel	134
Test Mode	802.11ac-VHT40 (CDD Mode)		
Remark	1. Average measurement was not performed if peak level lower than average limit. 2. Other frequency was 20dB below limit line within 1-18GHz, there is not show in the report.		

Mark	Frequency (MHz)	Reading Level (dB μ V)	Factor (dB)	Measure Level (dB μ V/m)	Limit (dB μ V/m)	Margin (dB)	Detector	Polarization
	8242.0	35.8	10.9	46.7	74.0	-27.3	Peak	Horizontal
	11166.0	37.1	15.1	52.2	74.0	-21.8	Peak	Horizontal
*	12891.5	34.3	14.7	49.0	68.2	-19.2	Peak	Horizontal
*	17014.0	40.9	18.4	59.3	68.2	-8.9	Peak	Horizontal
	8259.0	37.9	11.1	49.0	74.0	-25.0	Peak	Vertical
	11829.0	36.3	14.9	51.2	74.0	-22.8	Peak	Vertical
*	12891.5	35.6	14.7	50.3	68.2	-17.9	Peak	Vertical
*	17022.5	36.6	18.5	55.1	68.2	-13.1	Peak	Vertical

Note 1: "*" is not in restricted band, its limit is -27dBm/MHz. At a distance of 3 meters, the field strength limit in dB μ V/m can be determined by adding a "conversion" factor of 95.2dB to the EIRP limit of -27dBm/MHz to obtain the limit for out of band spurious emissions.

Note 2: Measure Level (dB μ V/m) = Reading Level (dB μ V) + Factor (dB)

Factor (dB) = Cable Loss (dB) + Antenna Factor (dB/m) - Pre_Amplifier Gain (dB)

Test Site	WZ-AC2	Test Engineer	Buter Shi
Test Date	2021/01/02	Test Channel	142
Test Mode	802.11ac-VHT40 (CDD Mode)		
Remark	1. Average measurement was not performed if peak level lower than average limit. 2. Other frequency was 20dB below limit line within 1-18GHz, there is not show in the report.		

Mark	Frequency (MHz)	Reading Level (dB μ V)	Factor (dB)	Measure Level (dB μ V/m)	Limit (dB μ V/m)	Margin (dB)	Detector	Polarization
	8386.5	37.2	10.7	47.9	74.0	-26.1	Peak	Horizontal
	11455.0	36.0	15.3	51.3	74.0	-22.7	Peak	Horizontal
*	13121.0	36.3	14.8	51.1	68.2	-17.1	Peak	Horizontal
*	17107.5	40.0	18.7	58.7	68.2	-9.5	Peak	Horizontal
	8437.5	37.4	10.8	48.2	74.0	-25.8	Peak	Vertical
	11208.5	36.0	15.1	51.1	74.0	-22.9	Peak	Vertical
*	13180.5	36.0	14.8	50.8	68.2	-17.4	Peak	Vertical
*	16674.0	37.0	17.3	54.3	68.2	-13.9	Peak	Vertical

Note 1: "*" is not in restricted band, its limit is -27dBm/MHz. At a distance of 3 meters, the field strength limit in dB μ V/m can be determined by adding a "conversion" factor of 95.2dB to the EIRP limit of -27dBm/MHz to obtain the limit for out of band spurious emissions.

Note 2: Measure Level (dB μ V/m) = Reading Level (dB μ V) + Factor (dB)

Factor (dB) = Cable Loss (dB) + Antenna Factor (dB/m) - Pre_Amplifier Gain (dB)

Test Site	WZ-AC2	Test Engineer	Buter Shi
Test Date	2021/01/02	Test Channel	151
Test Mode	802.11ac-VHT40 (CDD Mode)		
Remark	1. Average measurement was not performed if peak level lower than average limit. 2. Other frequency was 20dB below limit line within 1-18GHz, there is not show in the report.		

Mark	Frequency (MHz)	Reading Level (dBμV)	Factor (dB)	Measure Level (dBμV/m)	Limit (dBμV/m)	Margin (dB)	Detector	Polarization
	8191.0	37.6	10.7	48.3	74.0	-25.7	Peak	Horizontal
	11378.5	35.9	15.3	51.2	74.0	-22.8	Peak	Horizontal
*	13061.5	36.3	14.8	51.1	68.2	-17.1	Peak	Horizontal
*	17235.0	39.2	18.0	57.2	68.2	-11.0	Peak	Horizontal
	8454.5	37.1	11.0	48.1	74.0	-25.9	Peak	Vertical
	11123.5	36.4	15.1	51.5	74.0	-22.5	Peak	Vertical
*	12925.5	35.7	14.7	50.4	68.2	-17.8	Peak	Vertical
*	17022.5	36.0	18.5	54.5	68.2	-13.7	Peak	Vertical

Note 1: "*" is not in restricted band, its limit is -27dBm/MHz. At a distance of 3 meters, the field strength limit in dBμV/m can be determined by adding a "conversion" factor of 95.2dB to the EIRP limit of -27dBm/MHz to obtain the limit for out of band spurious emissions.

Note 2: Measure Level (dBμV/m) = Reading Level (dBμV) + Factor (dB)

Factor (dB) = Cable Loss (dB) + Antenna Factor (dB/m) - Pre_Amplifier Gain (dB)

Test Site	WZ-AC2	Test Engineer	Buter Shi
Test Date	2021/01/02	Test Channel	159
Test Mode	802.11ac-VHT40 (CDD Mode)		
Remark	1. Average measurement was not performed if peak level lower than average limit. 2. Other frequency was 20dB below limit line within 1-18GHz, there is not show in the report.		

Mark	Frequency (MHz)	Reading Level (dBμV)	Factor (dB)	Measure Level (dBμV/m)	Limit (dBμV/m)	Margin (dB)	Detector	Polarization
	8386.5	37.8	10.7	48.5	74.0	-25.5	Peak	Horizontal
	11667.5	36.5	15.1	51.6	74.0	-22.4	Peak	Horizontal
*	12951.0	35.3	14.8	50.1	68.2	-18.1	Peak	Horizontal
*	17090.5	36.8	18.9	55.7	68.2	-12.5	Peak	Horizontal
	8242.0	36.7	10.9	47.6	74.0	-26.4	Peak	Vertical
	11242.5	35.6	15.5	51.1	74.0	-22.9	Peak	Vertical
*	13044.5	36.0	14.8	50.8	68.2	-17.4	Peak	Vertical
*	16725.0	37.1	18.0	55.1	68.2	-13.1	Peak	Vertical

Note 1: "*" is not in restricted band, its limit is -27dBm/MHz. At a distance of 3 meters, the field strength limit in dBμV/m can be determined by adding a "conversion" factor of 95.2dB to the EIRP limit of -27dBm/MHz to obtain the limit for out of band spurious emissions.

Note 2: Measure Level (dBμV/m) = Reading Level (dBμV) + Factor (dB)

Factor (dB) = Cable Loss (dB) + Antenna Factor (dB/m) - Pre_Amplifier Gain (dB)

Test Site	WZ-AC2	Test Engineer	Buter Shi
Test Date	2021/01/02	Test Channel	42
Test Mode	802.11ac-VHT80 (CDD Mode)		
Remark	1. Average measurement was not performed if peak level lower than average limit. 2. Other frequency was 20dB below limit line within 1-18GHz, there is not show in the report.		

Mark	Frequency (MHz)	Reading Level (dB μ V)	Factor (dB)	Measure Level (dB μ V/m)	Limit (dB μ V/m)	Margin (dB)	Detector	Polarization
*	8828.5	36.6	12.0	48.6	68.2	-19.6	Peak	Horizontal
*	9602.0	36.4	13.5	49.9	68.2	-18.3	Peak	Horizontal
	11480.5	36.4	15.5	51.9	74.0	-22.1	Peak	Horizontal
	15577.5	37.5	15.4	52.9	74.0	-21.1	Peak	Horizontal
*	8794.5	35.9	11.9	47.8	68.2	-20.4	Peak	Vertical
*	9823.0	35.1	14.3	49.4	68.2	-18.8	Peak	Vertical
	11676.0	36.3	15.3	51.6	74.0	-22.4	Peak	Vertical
	15756.0	37.3	14.4	51.7	74.0	-22.3	Peak	Vertical

Note 1: "*" is not in restricted band, its limit is -27dBm/MHz. At a distance of 3 meters, the field strength limit in dB μ V/m can be determined by adding a "conversion" factor of 95.2dB to the EIRP limit of -27dBm/MHz to obtain the limit for out of band spurious emissions.

Note 2: Measure Level (dB μ V/m) = Reading Level (dB μ V) + Factor (dB)

Factor (dB) = Cable Loss (dB) + Antenna Factor (dB/m) - Pre_Amplifier Gain (dB)

Test Site	WZ-AC2	Test Engineer	Buter Shi
Test Date	2021/01/02	Test Channel	58
Test Mode	802.11ac-VHT80 (CDD Mode)		
Remark	1. Average measurement was not performed if peak level lower than average limit. 2. Other frequency was 20dB below limit line within 1-18GHz, there is not show in the report.		

Mark	Frequency (MHz)	Reading Level (dB μ V)	Factor (dB)	Measure Level (dB μ V/m)	Limit (dB μ V/m)	Margin (dB)	Detector	Polarization
*	8820.0	36.0	12.3	48.3	68.2	-19.9	Peak	Horizontal
*	10341.5	35.1	14.8	49.9	68.2	-18.3	Peak	Horizontal
	11820.5	37.0	14.9	51.9	74.0	-22.1	Peak	Horizontal
	15841.0	41.6	14.4	56.0	74.0	-18.0	Peak	Horizontal
*	8769.0	35.3	11.9	47.2	68.2	-21.0	Peak	Vertical
*	10035.5	34.2	14.5	48.7	68.2	-19.5	Peak	Vertical
	11591.0	36.6	15.2	51.8	74.0	-22.2	Peak	Vertical
	15637.0	36.8	15.1	51.9	74.0	-22.1	Peak	Vertical

Note 1: "*" is not in restricted band, its limit is -27dBm/MHz. At a distance of 3 meters, the field strength limit in dB μ V/m can be determined by adding a "conversion" factor of 95.2dB to the EIRP limit of -27dBm/MHz to obtain the limit for out of band spurious emissions.

Note 2: Measure Level (dB μ V/m) = Reading Level (dB μ V) + Factor (dB)

Factor (dB) = Cable Loss (dB) + Antenna Factor (dB/m) - Pre_Amplifier Gain (dB)

Test Site	WZ-AC2	Test Engineer	Buter Shi
Test Date	2021/01/02	Test Channel	106
Test Mode	802.11ac-VHT80 (CDD Mode)		
Remark	1. Average measurement was not performed if peak level lower than average limit. 2. Other frequency was 20dB below limit line within 1-18GHz, there is not show in the report.		

Mark	Frequency (MHz)	Reading Level (dBμV)	Factor (dB)	Measure Level (dBμV/m)	Limit (dBμV/m)	Margin (dB)	Detector	Polarization
*	8616.0	36.9	11.7	48.6	68.2	-19.6	Peak	Horizontal
*	9993.0	36.0	14.3	50.3	68.2	-17.9	Peak	Horizontal
	11778.0	37.0	15.0	52.0	74.0	-22.0	Peak	Horizontal
	15450.0	36.8	15.6	52.4	74.0	-21.6	Peak	Horizontal
*	8956.0	37.0	12.0	49.0	68.2	-19.2	Peak	Vertical
*	9797.5	35.6	14.3	49.9	68.2	-18.3	Peak	Vertical
	11489.0	35.7	15.6	51.3	74.0	-22.7	Peak	Vertical
	15909.0	37.1	14.5	51.6	74.0	-22.4	Peak	Vertical

Note 1: "*" is not in restricted band, its limit is -27dBm/MHz. At a distance of 3 meters, the field strength limit in dBμV/m can be determined by adding a "conversion" factor of 95.2dB to the EIRP limit of -27dBm/MHz to obtain the limit for out of band spurious emissions.

Note 2: Measure Level (dBμV/m) = Reading Level (dBμV) + Factor (dB)

Factor (dB) = Cable Loss (dB) + Antenna Factor (dB/m) - Pre_Amplifier Gain (dB)

Test Site	WZ-AC2	Test Engineer	Buter Shi
Test Date	2021/01/02	Test Channel	122
Test Mode	802.11ac-VHT80 (CDD Mode)		
Remark	1. Average measurement was not performed if peak level lower than average limit. 2. Other frequency was 20dB below limit line within 1-18GHz, there is not show in the report.		

Mark	Frequency (MHz)	Reading Level (dB μ V)	Factor (dB)	Measure Level (dB μ V/m)	Limit (dB μ V/m)	Margin (dB)	Detector	Polarization
	8276.0	37.4	10.6	48.0	74.0	-26.0	Peak	Horizontal
	11429.5	34.3	15.3	49.6	74.0	-24.4	Peak	Horizontal
*	13104.0	36.6	14.8	51.4	68.2	-16.8	Peak	Horizontal
*	16844.0	38.2	17.9	56.1	68.2	-12.1	Peak	Horizontal
	8242.0	37.0	10.9	47.9	74.0	-26.1	Peak	Vertical
	11633.5	36.7	14.9	51.6	74.0	-22.4	Peak	Vertical
*	12959.5	35.6	14.9	50.5	68.2	-17.7	Peak	Vertical
*	16742.0	36.8	17.8	54.6	68.2	-13.6	Peak	Vertical

Note 1: "*" is not in restricted band, its limit is -27dBm/MHz. At a distance of 3 meters, the field strength limit in dB μ V/m can be determined by adding a "conversion" factor of 95.2dB to the EIRP limit of -27dBm/MHz to obtain the limit for out of band spurious emissions.

Note 2: Measure Level (dB μ V/m) = Reading Level (dB μ V) + Factor (dB)

Factor (dB) = Cable Loss (dB) + Antenna Factor (dB/m) - Pre_Amplifier Gain (dB)

Test Site	WZ-AC2	Test Engineer	Buter Shi
Test Date	2021/01/02	Test Channel	138
Test Mode	802.11ac-VHT80 (CDD Mode)		
Remark	1. Average measurement was not performed if peak level lower than average limit. 2. Other frequency was 20dB below limit line within 1-18GHz, there is not show in the report.		

Mark	Frequency (MHz)	Reading Level (dB μ V)	Factor (dB)	Measure Level (dB μ V/m)	Limit (dB μ V/m)	Margin (dB)	Detector	Polarization
	8429.0	35.4	10.8	46.2	74.0	-27.8	Peak	Horizontal
	11378.5	36.3	15.3	51.6	74.0	-22.4	Peak	Horizontal
*	12951.0	35.0	14.8	49.8	68.2	-18.4	Peak	Horizontal
*	17099.0	39.1	18.8	57.9	68.2	-10.3	Peak	Horizontal
	8140.0	37.1	11.0	48.1	74.0	-25.9	Peak	Vertical
	11591.0	36.1	15.2	51.3	74.0	-22.7	Peak	Vertical
*	12976.5	36.0	14.8	50.8	68.2	-17.4	Peak	Vertical
*	17082.0	36.5	18.9	55.4	68.2	-12.8	Peak	Vertical

Note 1: "*" is not in restricted band, its limit is -27dBm/MHz. At a distance of 3 meters, the field strength limit in dB μ V/m can be determined by adding a "conversion" factor of 95.2dB to the EIRP limit of -27dBm/MHz to obtain the limit for out of band spurious emissions.

Note 2: Measure Level (dB μ V/m) = Reading Level (dB μ V) + Factor (dB)

Factor (dB) = Cable Loss (dB) + Antenna Factor (dB/m) - Pre_Amplifier Gain (dB)

Test Site	WZ-AC2	Test Engineer	Buter Shi
Test Date	2021/01/02	Test Channel	155
Test Mode	802.11ac-VHT80 (CDD Mode)		
Remark	1. Average measurement was not performed if peak level lower than average limit. 2. Other frequency was 20dB below limit line within 1-18GHz, there is not show in the report.		

Mark	Frequency (MHz)	Reading Level (dB μ V)	Factor (dB)	Measure Level (dB μ V/m)	Limit (dB μ V/m)	Margin (dB)	Detector	Polarization
	8403.5	37.6	11.0	48.6	74.0	-25.4	Peak	Horizontal
	11489.0	35.9	15.6	51.5	74.0	-22.5	Peak	Horizontal
*	12891.5	36.8	14.7	51.5	68.2	-16.7	Peak	Horizontal
*	17039.5	36.4	18.5	54.9	68.2	-13.3	Peak	Horizontal
	8403.5	37.6	11.0	48.6	74.0	-25.4	Peak	Vertical
	11140.5	36.3	15.2	51.5	74.0	-22.5	Peak	Vertical
*	12891.5	36.8	14.7	51.5	68.2	-16.7	Peak	Vertical
*	16759.0	37.0	17.8	54.8	68.2	-13.4	Peak	Vertical

Note 1: "*" is not in restricted band, its limit is -27dBm/MHz. At a distance of 3 meters, the field strength limit in dB μ V/m can be determined by adding a "conversion" factor of 95.2dB to the EIRP limit of -27dBm/MHz to obtain the limit for out of band spurious emissions.

Note 2: Measure Level (dB μ V/m) = Reading Level (dB μ V) + Factor (dB)

Factor (dB) = Cable Loss (dB) + Antenna Factor (dB/m) - Pre_Amplifier Gain (dB)

The Result of Radiated Emission below 1GHz:

Site: WZ-AC2	Time: 2021/01/11 - 19:24
Limit: FCC_Part15.209_RE(3m)	Engineer: Antony Yang
Probe: WZ-AC2_VULB9162_0.03-7GHz	Polarity: Horizontal
EUT: GPON ONT	Power: AC 120V/60Hz
Test Mode: Transmit by 802.11ac-VHT40 at channel 5190MHz (CDD Mode)	

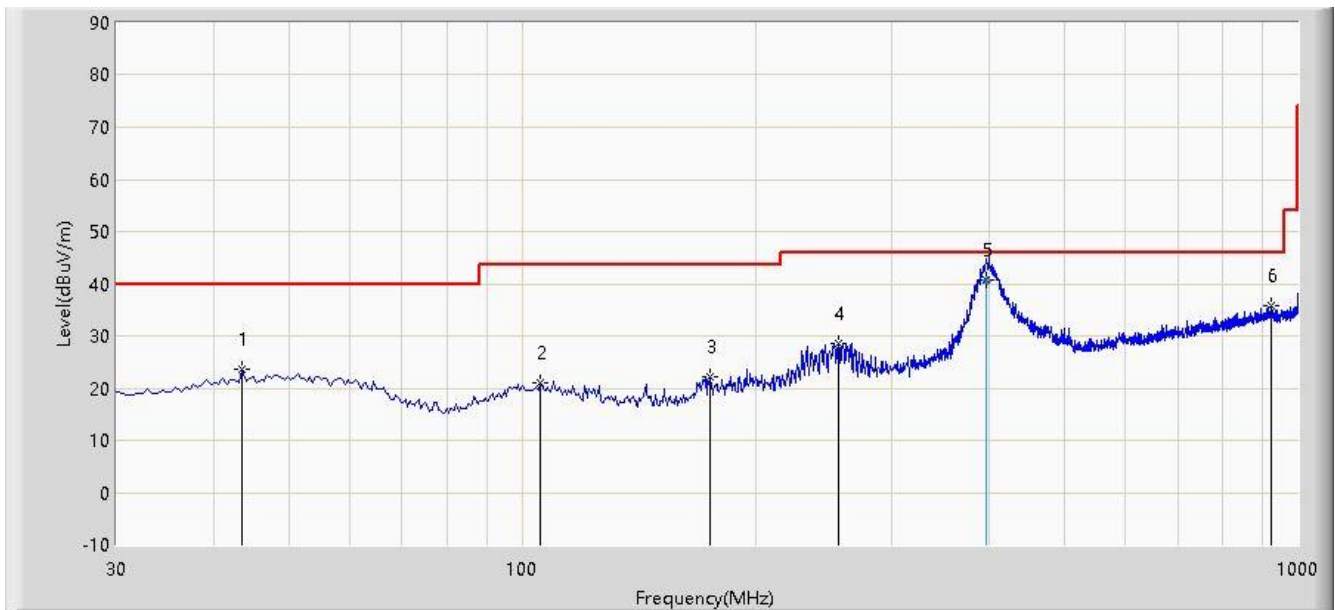

No	Flag	Mark	Frequency (MHz)	Measure Level (dBuV/m)	Reading Level (dBuV)	Margin (dB)	Limit (dBuV/m)	Factor (dB)	Type
1			43.580	23.615	3.261	-16.385	40.000	20.355	PK
2			105.660	21.048	2.500	-22.452	43.500	18.548	PK
3			174.530	22.157	5.670	-21.343	43.500	16.487	PK
4			255.525	28.649	8.409	-17.351	46.000	20.240	PK
5		*	396.260	40.796	17.155	-5.204	46.000	23.640	QP
6			923.370	35.829	4.162	-10.171	46.000	31.666	PK

Note 1: Measure Level (dB μ V/m) = Reading Level (dB μ V) + Factor (dB)

Factor (dB) = Cable Loss (dB) + Antenna Factor (dB/m)

Note 2: QP measurement was not performed when peak measure level was lower than the QP limit by more than 10dB.

Note 3: The amplitude of radiated emissions (frequency range from 9kHz to 30MHz and 18GHz to 40GHz) is that proximity to ambient noise, which also are attenuated more than 20 dB below the permissible value.

Therefore, the data is not presented in the report.

Site: WZ-AC2	Time: 2021/01/11 - 19:26
Limit: FCC_Part15.209_RE(3m)	Engineer: Antony Yang
Probe: WZ-AC2_VULB9162_0.03-7GHz	Polarity: Vertical
EUT: GPON ONT	Power: AC 120V/60Hz
Test Mode: Transmit by 802.11ac-VHT40 at channel 5190MHz (CDD Mode)	

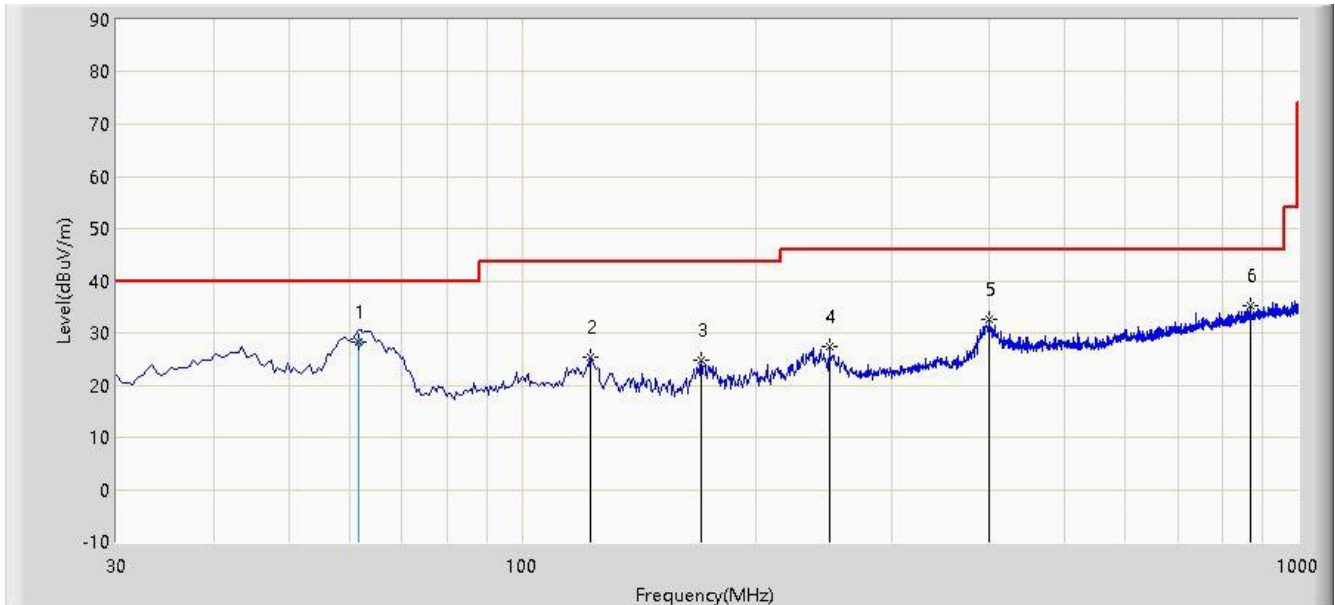

No	Flag	Mark	Frequency (MHz)	Measure Level (dBuV/m)	Reading Level (dBuV)	Margin (dB)	Limit (dBuV/m)	Factor (dB)	Type
1			61.525	28.243	9.269	-11.757	40.000	18.974	QP
2			122.635	25.410	8.917	-18.090	43.500	16.493	PK
3			170.165	24.816	8.533	-18.684	43.500	16.283	PK
4			249.220	27.465	7.456	-18.535	46.000	20.009	PK
5			400.055	32.558	8.816	-13.442	46.000	23.743	PK
6		*	869.535	35.208	3.922	-10.792	46.000	31.286	PK

Note 1: Measure Level (dBuV/m) = Reading Level (dBuV) + Factor (dB)

Factor (dB) = Cable Loss (dB) + Antenna Factor (dB/m)

Note 2: QP measurement was not performed when peak measure level was lower than the QP limit by more than 10dB.

Note 3: The amplitude of radiated emissions (frequency range from 9kHz to 30MHz and 18GHz to 40GHz) is that proximity to ambient noise, which also are attenuated more than 20 dB below the permissible value.

Therefore, the data is not presented in the report.

6.9. Radiated Restricted Band Edge Measurement

6.9.1. Test Limit

For 15.205 Requirement:

Radiated emissions which fall in the restricted bands, as defined in Section 15.205(a) of FCC part 15, must also comply with the radiated emission limits specified in Section 15.209(a).

Frequency (MHz)	Frequency (MHz)	Frequency (MHz)	Frequency (GHz)
0.090 - 0.110	16.42-16.423	399.9 - 410	4.5-5.15
¹ 0.495 - 0.505	16.69475-16.69525	608 - 614	5.35-5.46
2.1735-2.1905	16.80425-16.80475	960 - 1240	7.25-7.75
4.125-4.128	25.5 -25.67	1300 - 1427	8.025 - 8.5
4.17725-4.17775	37.5-38.25	1435-1626.5	9.0-9.2
4.20725-4.20775	73-74.6	1645.5-1646.5	9.3-9.5
6.215-6.218	74.8-75.2	1660 - 1710	10.6-12.7
6.26775-6.26825	108-121.94	1718.8-1722.2	13.25-13.4
6.31175-6.31225	123 - 138	2200 - 2300	14.47-14.5
8.291-8.294	149.9-150.05	2310–2390	15.35-16.2
8.362-8.366	156.52475-156.52525	2483.5 - 2500	17.7-21.4
8.37625-8.38675	156.7-156.9	2690 - 2900	22.01-23.12
8.41425-8.41475	162.0125-167.17	3260 - 3267	23.6-24.0
12.29-12.293	167.72-173.2	3332 - 3339	31.2-31.8
12.51975-12.52025	240 - 285	3345.8 - 3358	36.43-36.5
12.57675-12.57725	322-335.4	3600 - 4400	(²)
13.36-13.41	--	--	--

For 15.407(b) Requirement:

For transmitters operating in the 5.15-5.25 GHz band: All emissions outside of the 5.15-5.35 GHz band shall not exceed an e.i.r.p. of -27 dBm/MHz.

For transmitters operating in the 5.25-5.35 GHz band: All emissions outside of the 5.15-5.35 GHz band shall not exceed an e.i.r.p. of -27 dBm/MHz.

For transmitters operating in the 5.47-5.725 GHz band: All emissions outside of the 5.47-5.725 GHz band shall not exceed an e.i.r.p. of -27 dBm/MHz.

For transmitters operating in the 5.725-5.85 GHz band: All emissions within the frequency range

from the band edge to 10 MHz above or below the band edge shall not exceed an e.i.r.p. of -17 dBm/MHz; for frequencies 10 MHz or greater above or below the band edge, emissions shall not exceed an e.i.r.p. of -27 dBm/MHz.

Refer to KDB 789033 D02v02r01 G)2)c), as specified in § 15.407(b), emissions above 1000 MHz that are outside of the restricted bands are subject to a maximum emission limit of -27 dBm/MHz (or -17 dBm/MHz as specified in § 15.407(b)(4)). However, an out-of-band emission that complies with both the peak and average limits of § 15.209 is not required to satisfy the -27 dBm/MHz or -17 dBm/MHz maximum emission limit.

All out of band emissions appearing in a restricted band as specified in Section 15.205 of the Title 47CFR must not exceed the limits shown in Table per Section 15.209.

FCC Part 15 Subpart C Paragraph 15.209		
Frequency (MHz)	Field Strength ($\mu\text{V}/\text{m}$)	Measured Distance (m)
0.009 - 0.490	2400/F (kHz)	300
0.490 - 1.705	24000/F (kHz)	30
1.705 - 30	30	30
30 - 88	100	3
88 - 216	150	3
216 - 960	200	3
Above 960	500	3

6.9.2. Test Procedure Used

KDB 789033 D02v02r01- Section G

6.9.3. Test Setting

Peak Measurements above 1GHz

1. Analyzer center frequency was set to the frequency of the radiated spurious emission of interest
2. RBW = 1MHz
3. VBW = 3MHz
4. Detector = Peak
5. Sweep time = Auto couple
6. Trace mode = Max hold
7. Trace was allowed to stabilize

Average Measurements above 1GHz (Method VB)

1. Analyzer center frequency was set to the frequency of the radiated spurious emission of interest
2. RBW = 1MHz
3. VBW; if the EUT is configured to transmit with duty cycle $\geq 98\%$, set VBW = 10Hz
4. If the EUT duty cycle is $< 98\%$, set VBW $\geq 1/T$. T is the minimum transmission duration
5. Detector = Peak
6. Sweep time = Auto
7. Trace mode = Max hold
8. Trace was allowed to stabilize

6.9.4. Test Setup

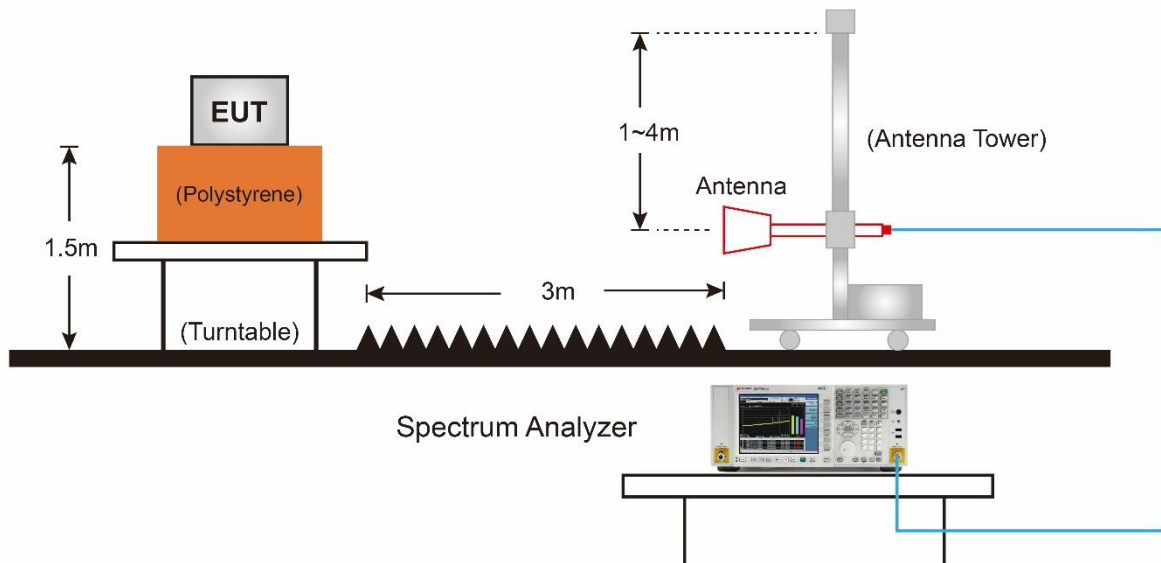

6.9.5. Test Result

Site: WZ-AC2	Time: 2020/09/09 - 18:14
Limit: FCC_Part15.209_RE(3m)	Engineer: Antony Yang
Probe: AC1_BBHA9120D_1-18GHz	Polarity: Horizontal
EUT: GPON ONT	Power: AC 120V/60Hz
Test Mode: Transmit by 802.11a at channel 5180MHz (CDD Mode)	

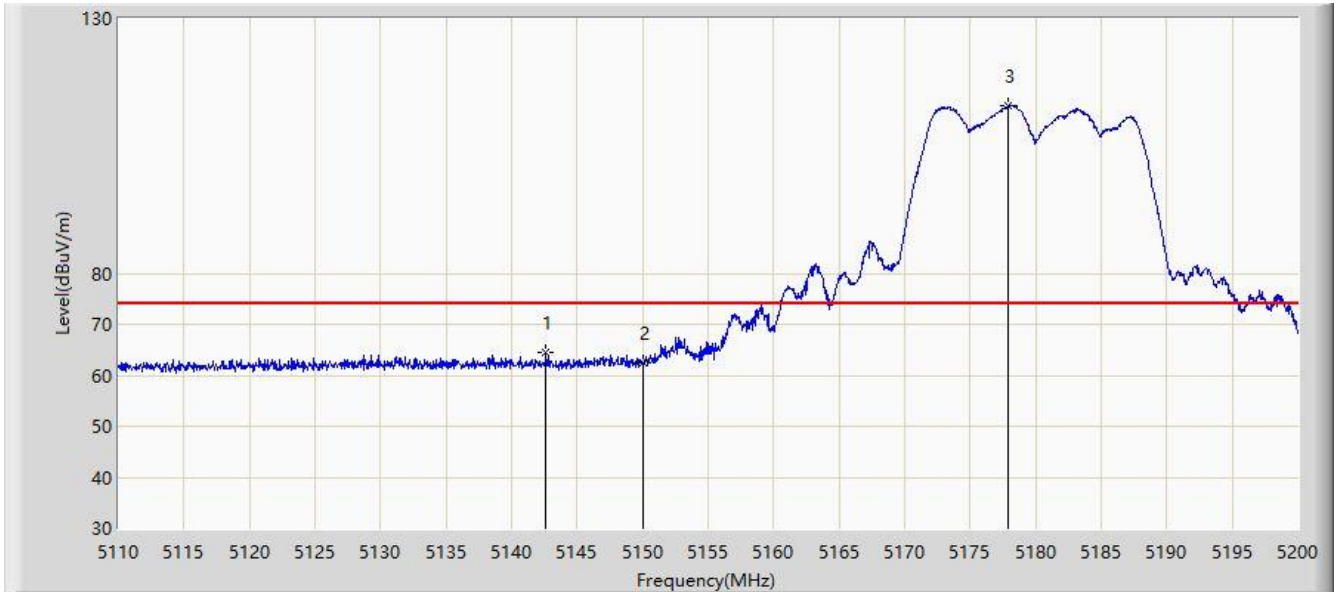

No	Flag	Mark	Frequency (MHz)	Measure Level (dBuV/m)	Reading Level (dBuV)	Margin (dB)	Limit (dBuV/m)	Factor (dB)	Type
1			5142.625	64.357	57.809	-9.643	74.000	6.548	PK
2			5150.000	62.480	56.028	-11.520	74.000	6.452	PK
3		*	5177.860	112.796	106.295	N/A	N/A	6.500	PK

Note: Measure Level (dB μ V/m) = Reading Level (dB μ V) + Factor (dB)

Factor (dB) = Cable Loss (dB) + Antenna Factor (dB/m) - Pre_Amplifier Gain (dB)

Site: WZ-AC2	Time: 2020/09/09 - 18:16
Limit: FCC_Part15.209_RE(3m)	Engineer: Antony Yang
Probe: AC1_BBHA9120D_1-18GHz	Polarity: Horizontal
EUT: GPON ONT	Power: AC 120V/60Hz
Test Mode: Transmit by 802.11a at channel 5180MHz (CDD Mode)	

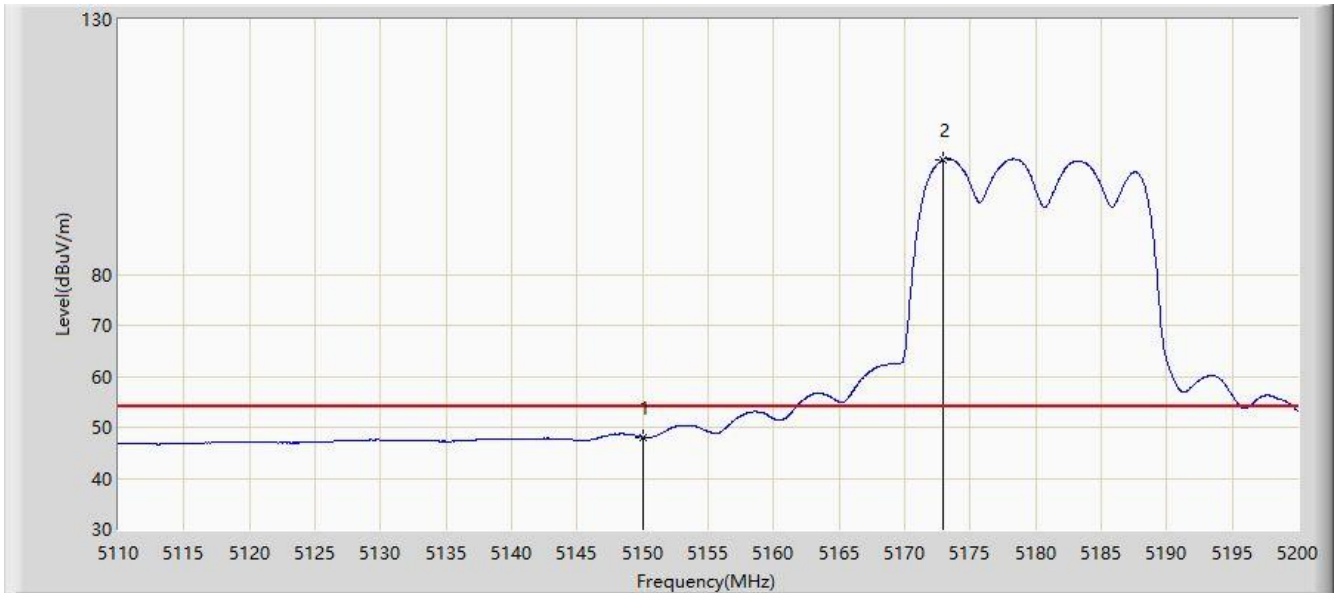

No	Flag	Mark	Frequency (MHz)	Measure Level (dBuV/m)	Reading Level (dBuV)	Margin (dB)	Limit (dBuV/m)	Factor (dB)	Type
1			5150.000	48.103	41.651	-5.897	54.000	6.452	AV
2		*	5172.955	102.569	96.101	N/A	N/A	6.468	AV

Note: Measure Level (dB μ V/m) = Reading Level (dB μ V) + Factor (dB)

Factor (dB) = Cable Loss (dB) + Antenna Factor (dB/m) - Pre_Amplifier Gain (dB)

Site: WZ-AC2	Time: 2020/09/09 - 18:18
Limit: FCC_Part15.209_RE(3m)	Engineer: Antony Yang
Probe: AC1_BBHA9120D_1-18GHz	Polarity: Vertical
EUT: GPON ONT	Power: AC 120V/60Hz
Test Mode: Transmit by 802.11a at channel 5180MHz (CDD Mode)	

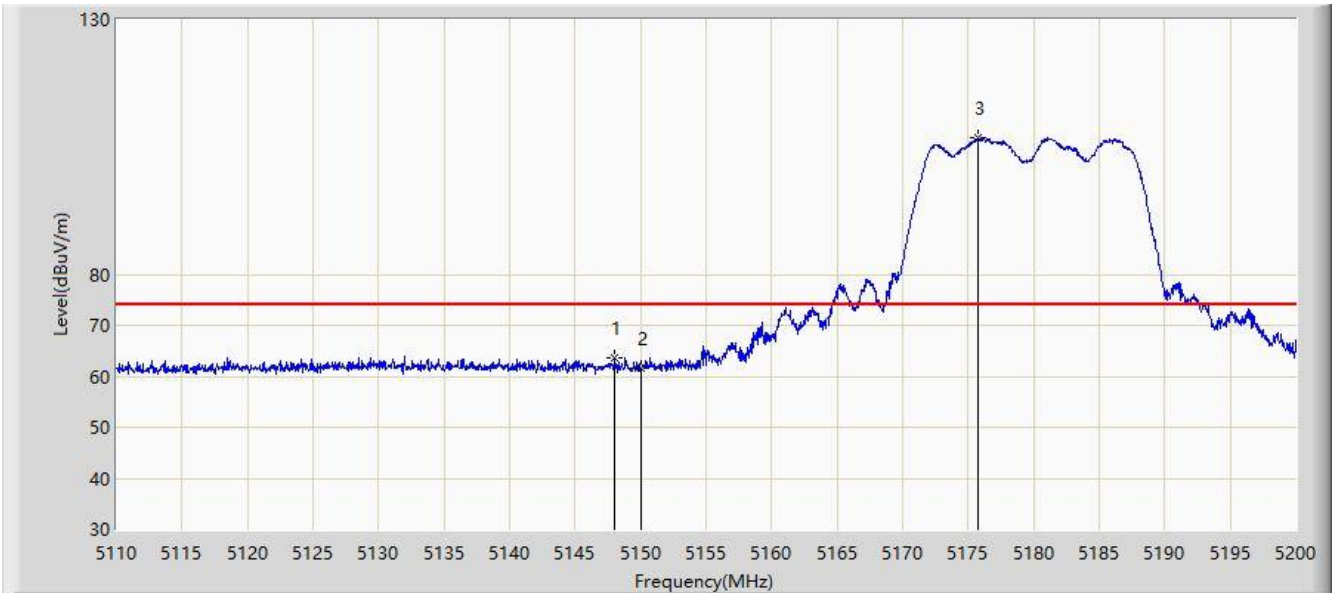

No	Flag	Mark	Frequency (MHz)	Measure Level (dBuV/m)	Reading Level (dBuV)	Margin (dB)	Limit (dBuV/m)	Factor (dB)	Type
1			5148.025	63.746	57.291	-10.254	74.000	6.454	PK
2			5150.000	61.511	55.059	-12.489	74.000	6.452	PK
3		*	5175.790	106.921	100.434	N/A	N/A	6.487	PK

Note: Measure Level (dB μ V/m) = Reading Level (dB μ V) + Factor (dB)

Factor (dB) = Cable Loss (dB) + Antenna Factor (dB/m) - Pre_Amplifier Gain (dB)

Site: WZ-AC2	Time: 2020/09/09 - 18:20
Limit: FCC_Part15.209_RE(3m)	Engineer: Antony Yang
Probe: AC1_BBHA9120D_1-18GHz	Polarity: Vertical
EUT: GPON ONT	Power: AC 120V/60Hz
Test Mode: Transmit by 802.11a at channel 5180MHz (CDD Mode)	

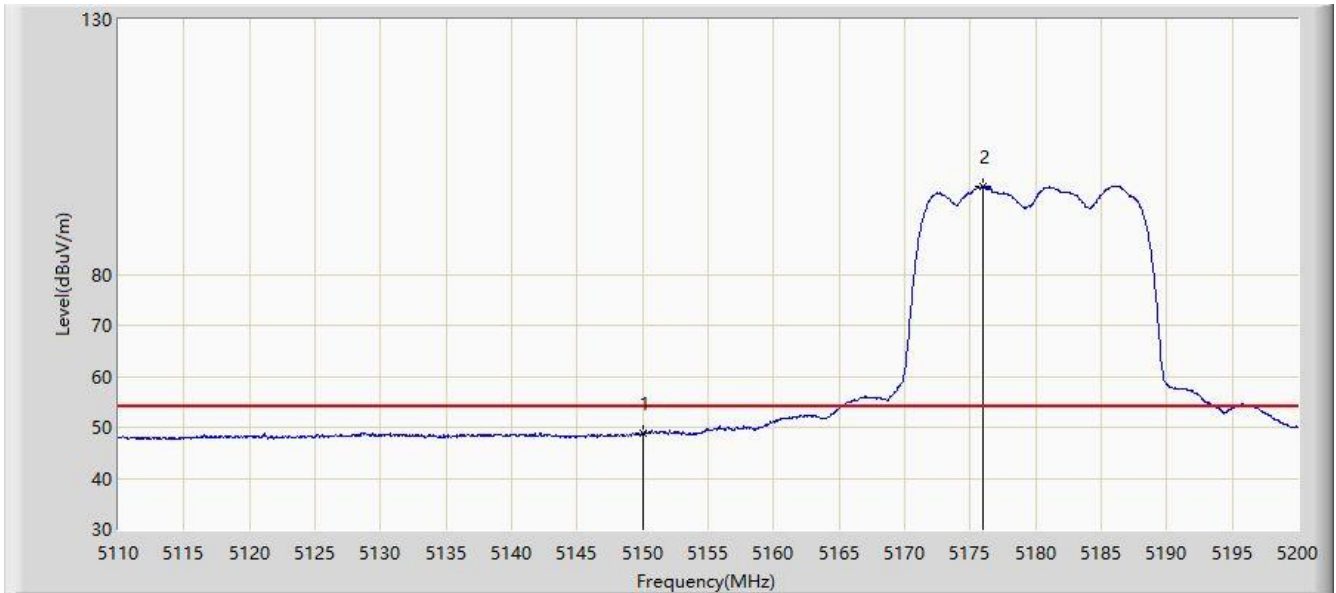

No	Flag	Mark	Frequency (MHz)	Measure Level (dBuV/m)	Reading Level (dBuV)	Margin (dB)	Limit (dBuV/m)	Factor (dB)	Type
1			5150.000	48.700	42.248	-5.300	54.000	6.452	AV
2		*	5175.925	97.256	90.768	N/A	N/A	6.487	AV

Note: Measure Level (dB μ V/m) = Reading Level (dB μ V) + Factor (dB)

Factor (dB) = Cable Loss (dB) + Antenna Factor (dB/m) - Pre_Amplifier Gain (dB)

Site: WZ-AC2	Time: 2020/09/09 - 18:24
Limit: FCC_Part15.209_RE(3m)	Engineer: Antony Yang
Probe: AC1_BBHA9120D_1-18GHz	Polarity: Horizontal
EUT: GPON ONT	Power: AC 120V/60Hz
Test Mode: Transmit by 802.11a at channel 5240MHz (CDD Mode)	

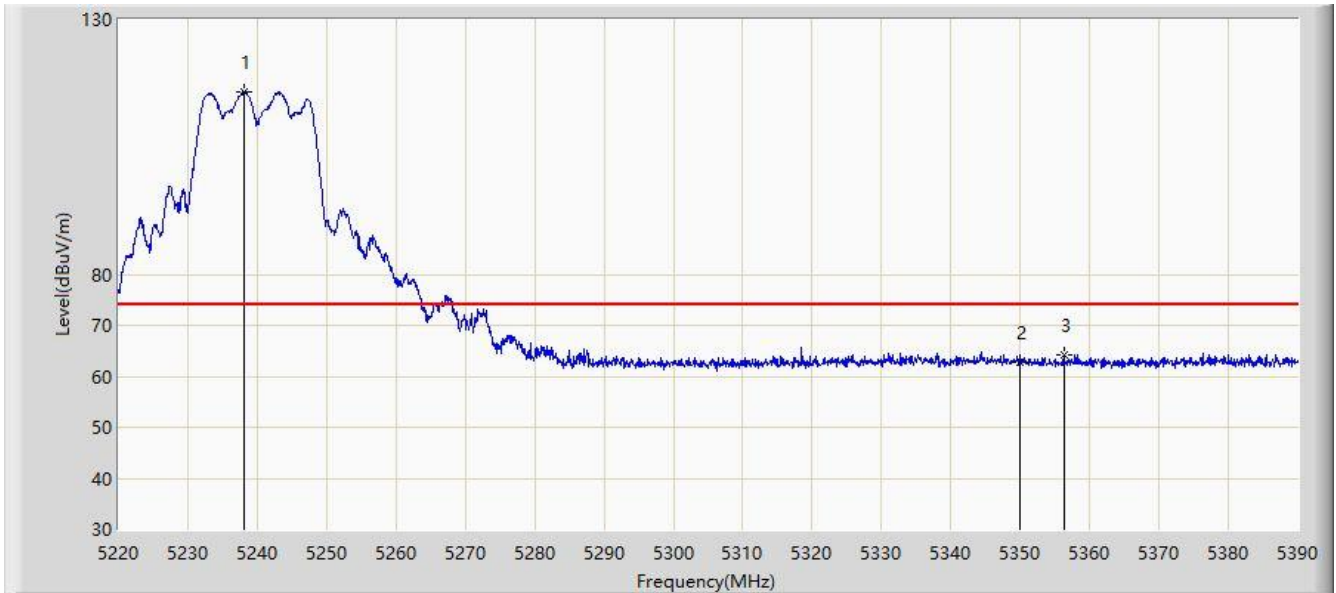

No	Flag	Mark	Frequency (MHz)	Measure Level (dBuV/m)	Reading Level (dBuV)	Margin (dB)	Limit (dBuV/m)	Factor (dB)	Type
1		*	5238.190	115.928	109.841	N/A	N/A	6.087	PK
2			5350.000	62.690	56.232	-11.310	74.000	6.458	PK
3			5356.255	64.135	57.850	-9.865	74.000	6.284	PK

Note: Measure Level (dB μ V/m) = Reading Level (dB μ V) + Factor (dB)

Factor (dB) = Cable Loss (dB) + Antenna Factor (dB/m) - Pre_Amplifier Gain (dB)

Site: WZ-AC2	Time: 2020/09/09 - 19:55
Limit: FCC_Part15.209_RE(3m)	Engineer: Antony Yang
Probe: AC1_BBHA9120D_1-18GHz	Polarity: Horizontal
EUT: GPON ONT	Power: AC 120V/60Hz
Test Mode: Transmit by 802.11a at channel 5240MHz (CDD Mode)	

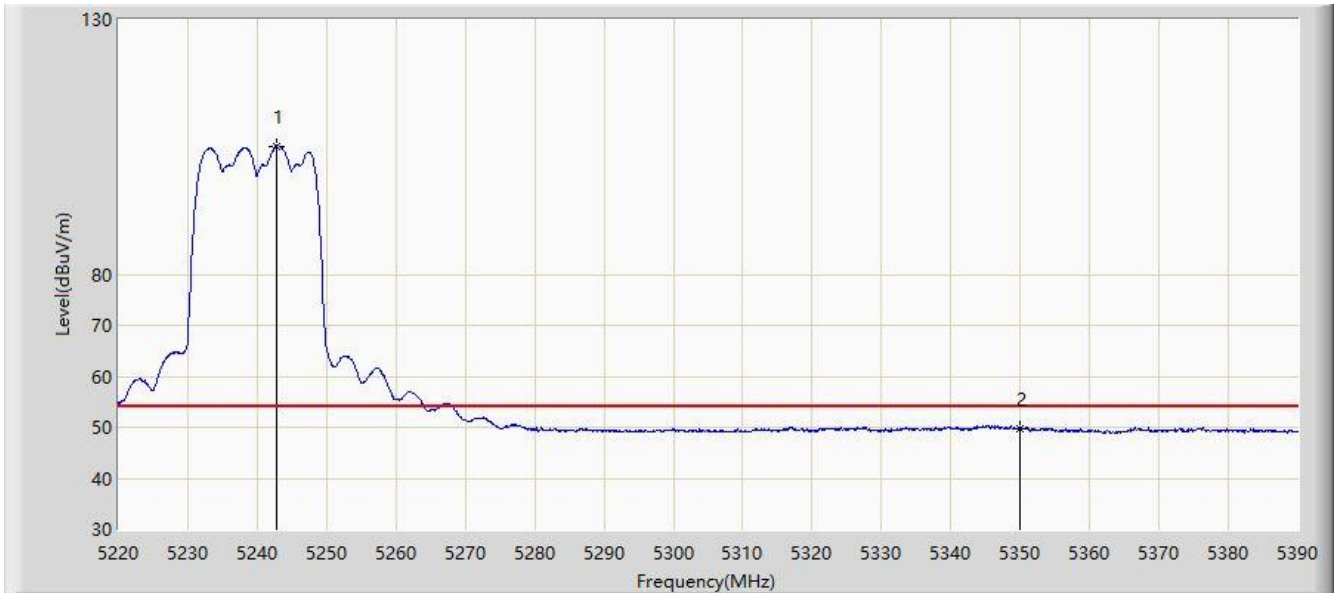

No	Flag	Mark	Frequency (MHz)	Measure Level (dBuV/m)	Reading Level (dBuV)	Margin (dB)	Limit (dBuV/m)	Factor (dB)	Type
1		*	5242.695	105.017	98.877	N/A	N/A	6.139	AV
2			5350.000	49.815	43.357	-4.185	54.000	6.458	AV

Note: Measure Level (dB μ V/m) = Reading Level (dB μ V) + Factor (dB)

Factor (dB) = Cable Loss (dB) + Antenna Factor (dB/m) - Pre_Amplifier Gain (dB)

Site: WZ-AC2	Time: 2020/09/09 - 19:59
Limit: FCC_Part15.209_RE(3m)	Engineer: Antony Yang
Probe: AC1_BBHA9120D_1-18GHz	Polarity: Vertical
EUT: GPON ONT	Power: AC 120V/60Hz
Test Mode: Transmit by 802.11a at channel 5240MHz (CDD Mode)	

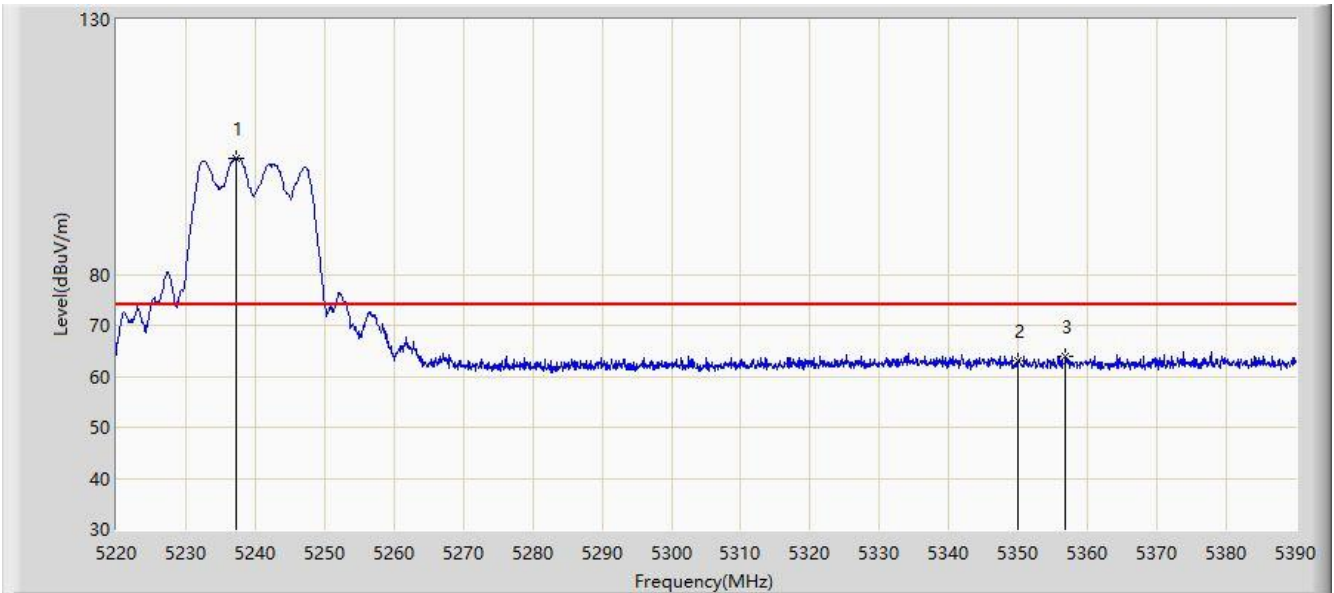

No	Flag	Mark	Frequency (MHz)	Measure Level (dBuV/m)	Reading Level (dBuV)	Margin (dB)	Limit (dBuV/m)	Factor (dB)	Type
1		*	5237.170	102.832	96.746	N/A	N/A	6.086	PK
2			5350.000	62.927	56.469	-11.073	74.000	6.458	PK
3			5356.850	63.799	57.530	-10.201	74.000	6.270	PK

Note: Measure Level (dB μ V/m) = Reading Level (dB μ V) + Factor (dB)

Factor (dB) = Cable Loss (dB) + Antenna Factor (dB/m) - Pre_Amplifier Gain (dB)

Site: WZ-AC2	Time: 2020/09/09 - 20:00
Limit: FCC_Part15.209_RE(3m)	Engineer: Antony Yang
Probe: AC1_BBHA9120D_1-18GHz	Polarity: Vertical
EUT: GPON ONT	Power: AC 120V/60Hz
Test Mode: Transmit by 802.11a at channel 5240MHz (CDD Mode)	

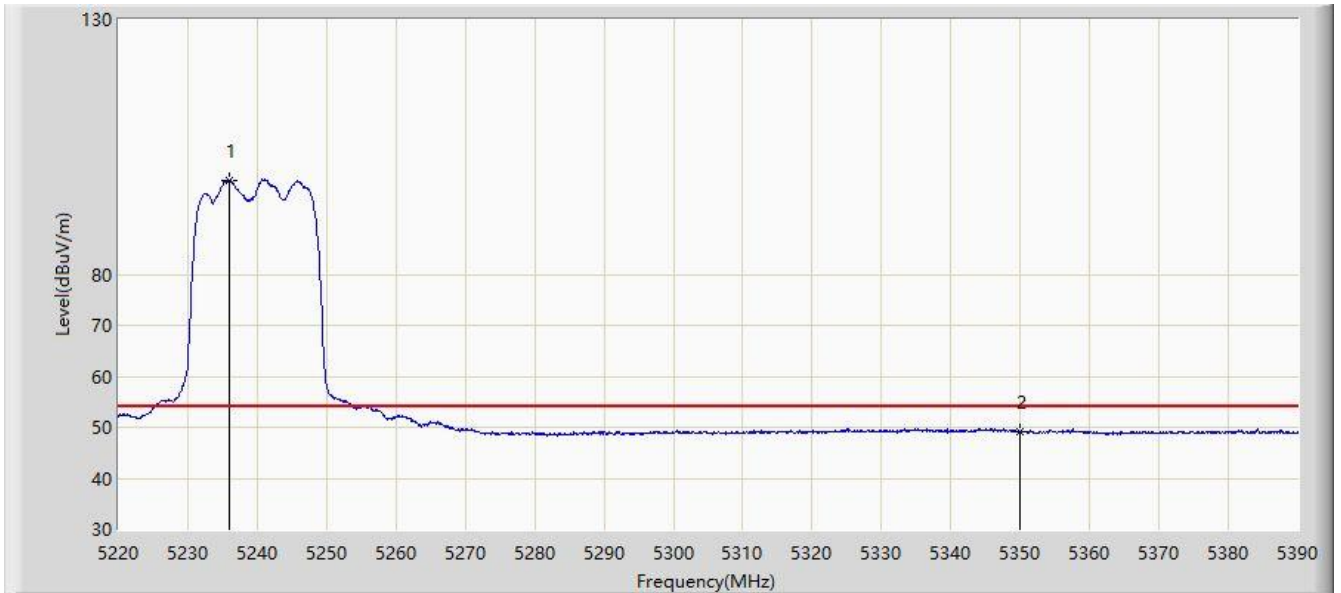

No	Flag	Mark	Frequency (MHz)	Measure Level (dBuV/m)	Reading Level (dBuV)	Margin (dB)	Limit (dBuV/m)	Factor (dB)	Type
1		*	5235.895	98.529	92.433	N/A	N/A	6.096	AV
2			5350.000	49.110	42.652	-4.890	54.000	6.458	AV

Note: Measure Level (dB μ V/m) = Reading Level (dB μ V) + Factor (dB)

Factor (dB) = Cable Loss (dB) + Antenna Factor (dB/m) - Pre_Amplifier Gain (dB)

Site: WZ-AC2	Time: 2020/09/09 - 20:03
Limit: FCC_Part15.209_RE(3m)	Engineer: Antony Yang
Probe: AC1_BBHA9120D_1-18GHz	Polarity: Horizontal
EUT: GPON ONT	Power: AC 120V/60Hz
Test Mode: Transmit by 802.11a at channel 5320MHz (CDD Mode)	

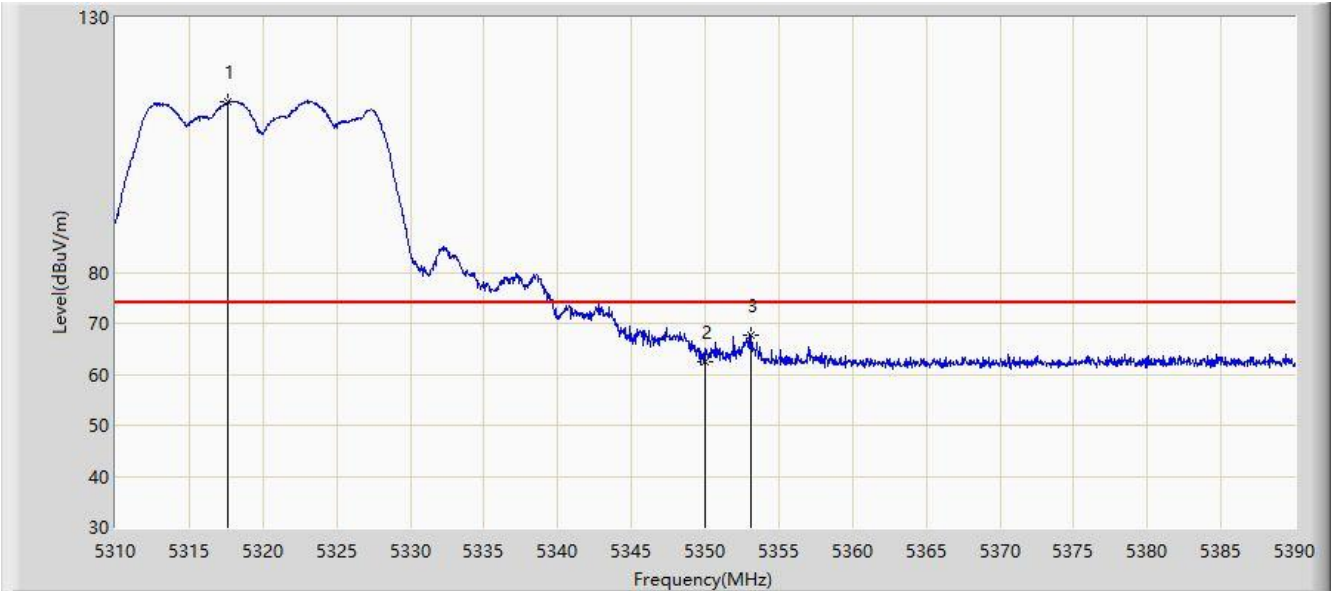

No	Flag	Mark	Frequency (MHz)	Measure Level (dBuV/m)	Reading Level (dBuV)	Margin (dB)	Limit (dBuV/m)	Factor (dB)	Type
1		*	5317.640	113.439	107.348	N/A	N/A	6.091	PK
2			5350.000	62.535	56.077	-11.465	74.000	6.458	PK
3			5353.080	67.722	61.355	-6.278	74.000	6.367	PK

Note: Measure Level (dBμV/m) = Reading Level (dBμV) + Factor (dB)

Factor (dB) = Cable Loss (dB) + Antenna Factor (dB/m) - Pre_Amplifier Gain (dB)

Site: WZ-AC2	Time: 2020/09/09 - 20:06
Limit: FCC_Part15.209_RE(3m)	Engineer: Antony Yang
Probe: AC1_BBHA9120D_1-18GHz	Polarity: Horizontal
EUT: GPON ONT	Power: AC 120V/60Hz
Test Mode: Transmit by 802.11a at channel 5320MHz (CDD Mode)	

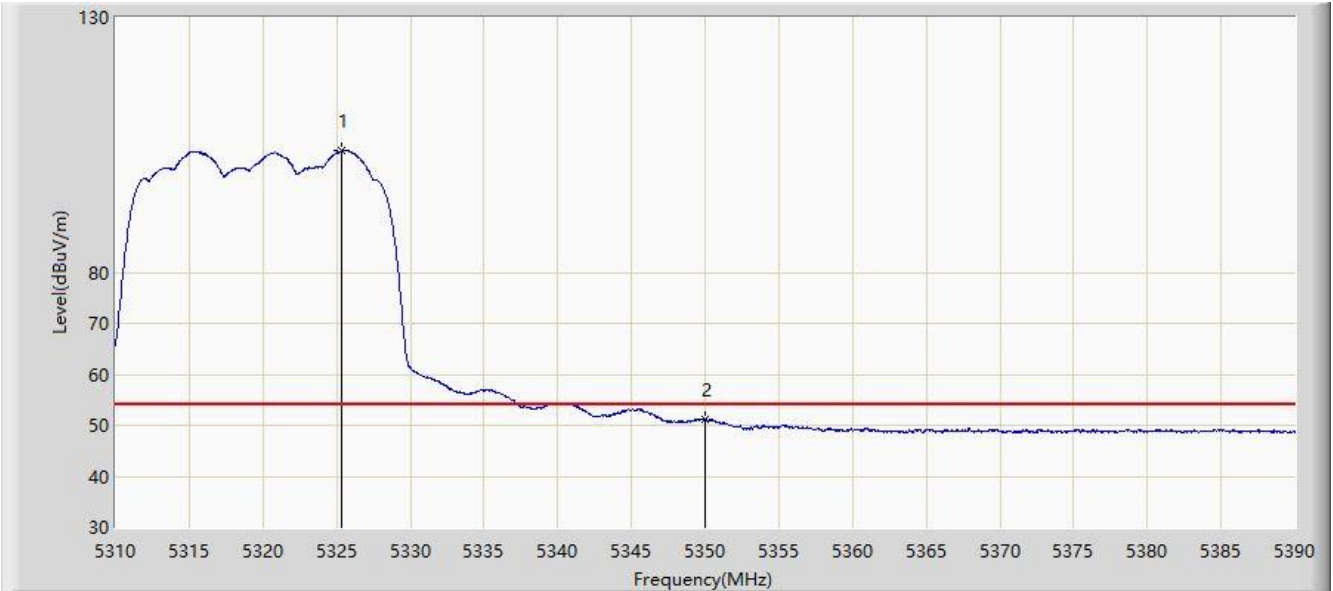

No	Flag	Mark	Frequency (MHz)	Measure Level (dBuV/m)	Reading Level (dBuV)	Margin (dB)	Limit (dBuV/m)	Factor (dB)	Type
1		*	5325.360	103.781	97.495	N/A	N/A	6.286	AV
2			5350.000	51.275	44.817	-2.725	54.000	6.458	AV

Note: Measure Level (dB μ V/m) = Reading Level (dB μ V) + Factor (dB)

Factor (dB) = Cable Loss (dB) + Antenna Factor (dB/m) - Pre_Amplifier Gain (dB)

Site: WZ-AC2	Time: 2020/09/09 - 20:08
Limit: FCC_Part15.209_RE(3m)	Engineer: Antony Yang
Probe: AC1_BBHA9120D_1-18GHz	Polarity: Vertical
EUT: GPON ONT	Power: AC 120V/60Hz
Test Mode: Transmit by 802.11a at channel 5320MHz (CDD Mode)	

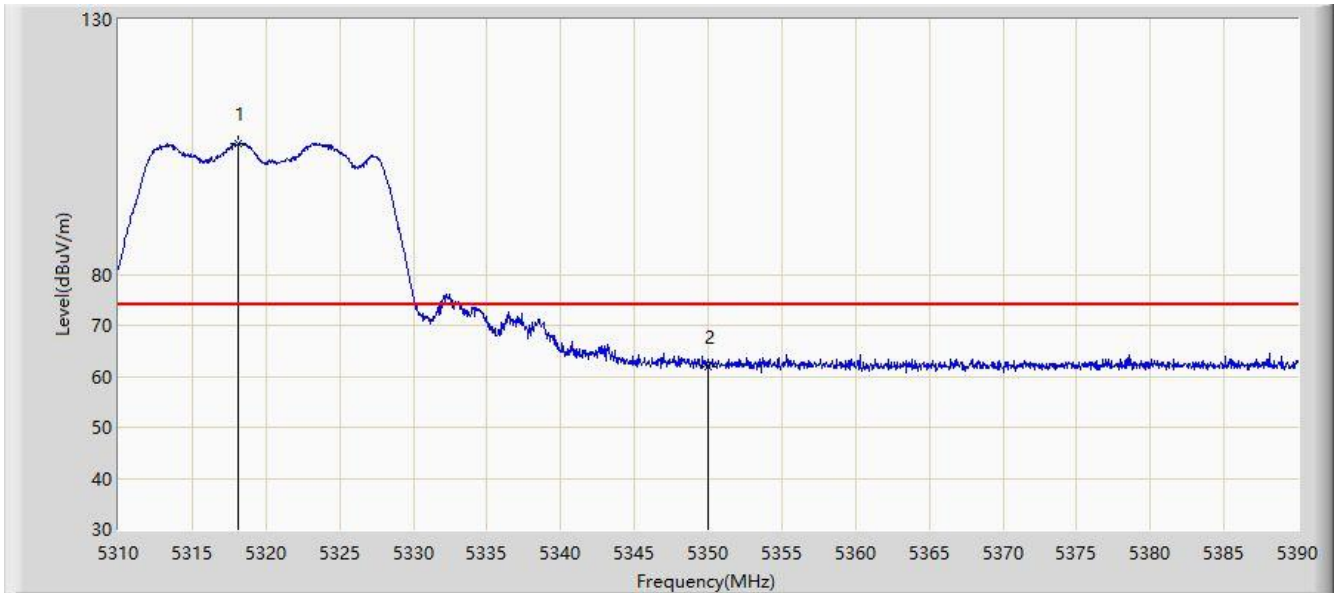

No	Flag	Mark	Frequency (MHz)	Measure Level (dBuV/m)	Reading Level (dBuV)	Margin (dB)	Limit (dBuV/m)	Factor (dB)	Type
1		*	5318.160	105.787	99.684	N/A	N/A	6.102	PK
2			5350.000	61.916	55.458	-12.084	74.000	6.458	PK

Note: Measure Level (dB μ V/m) = Reading Level (dB μ V) + Factor (dB)

Factor (dB) = Cable Loss (dB) + Antenna Factor (dB/m) - Pre_Amplifier Gain (dB)

Site: WZ-AC2	Time: 2020/09/09 - 20:10
Limit: FCC_Part15.209_RE(3m)	Engineer: Antony Yang
Probe: AC1_BBHA9120D_1-18GHz	Polarity: Vertical
EUT: GPON ONT	Power: AC 120V/60Hz
Test Mode: Transmit by 802.11a at channel 5320MHz (CDD Mode)	

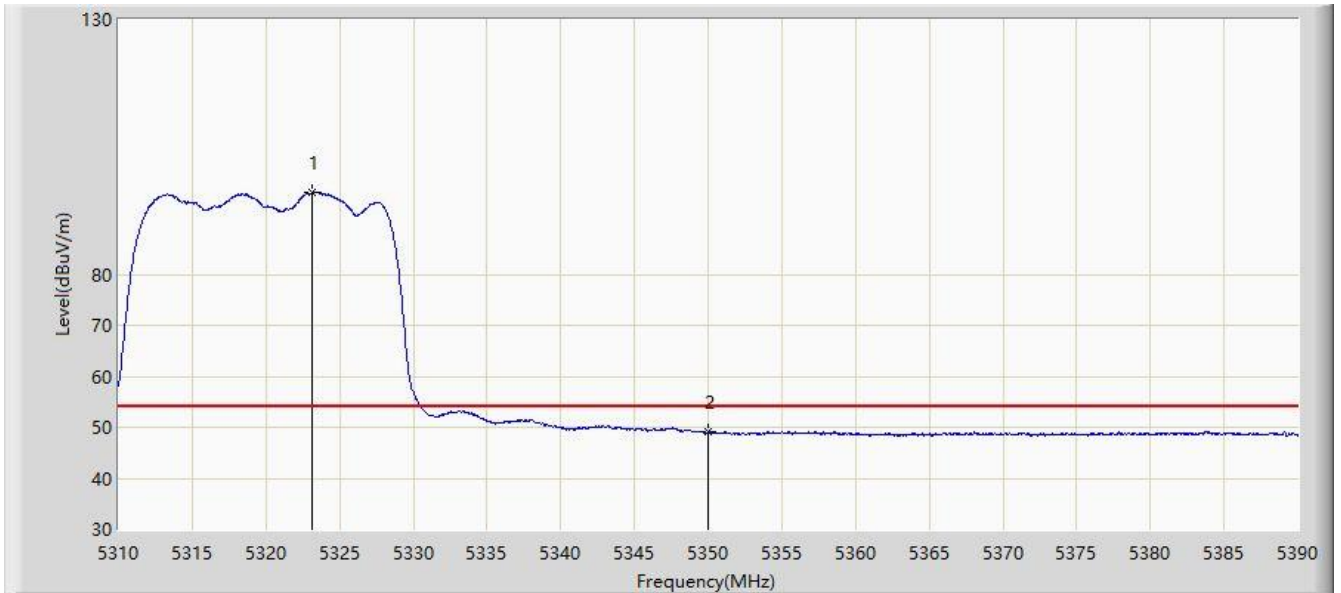

No	Flag	Mark	Frequency (MHz)	Measure Level (dBuV/m)	Reading Level (dBuV)	Margin (dB)	Limit (dBuV/m)	Factor (dB)	Type
1		*	5323.120	96.022	89.793	N/A	N/A	6.229	AV
2			5350.000	49.158	42.700	-4.842	54.000	6.458	AV

Note: Measure Level (dB μ V/m) = Reading Level (dB μ V) + Factor (dB)

Factor (dB) = Cable Loss (dB) + Antenna Factor (dB/m) - Pre_Amplifier Gain (dB)

Site: WZ-AC2	Time: 2020/09/09 - 20:50
Limit: FCC_Part15.209_RE(3m)	Engineer: Antony Yang
Probe: AC1_BBHA9120D_1-18GHz	Polarity: Horizontal
EUT: GPON ONT	Power: AC 120V/60Hz
Test Mode: Transmit by 802.11a at channel 5500MHz (CDD Mode)	

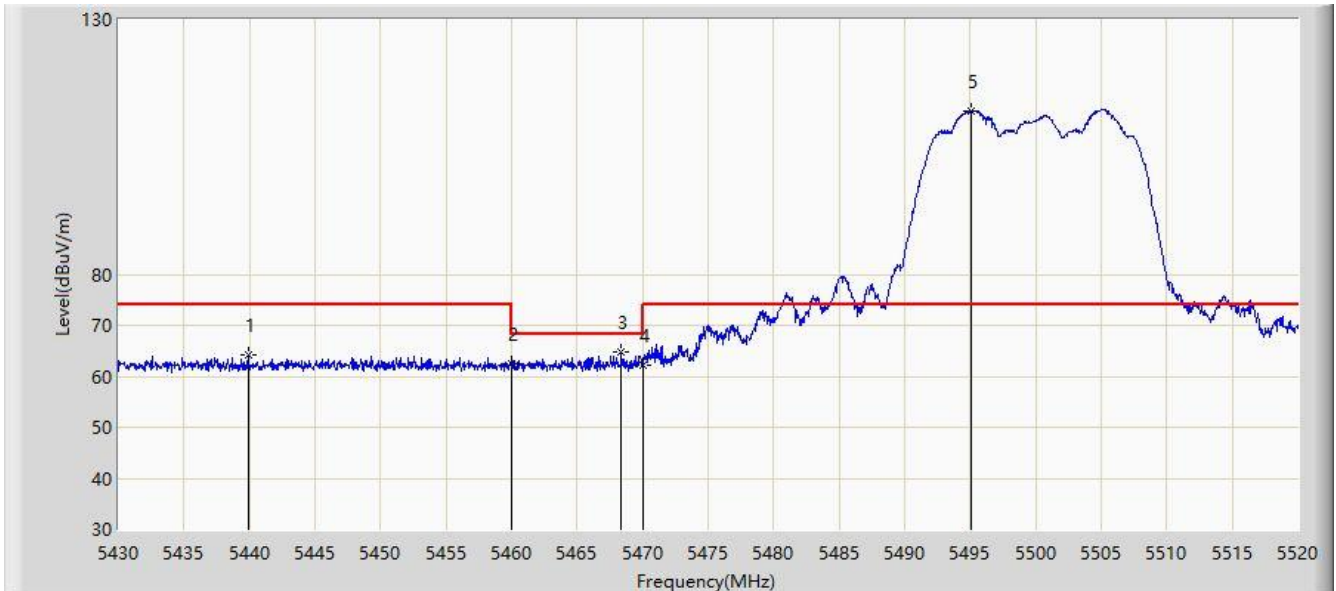

No	Flag	Mark	Frequency (MHz)	Measure Level (dBuV/m)	Reading Level (dBuV)	Margin (dB)	Limit (dBuV/m)	Factor (dB)	Type
1			5439.900	64.094	57.666	-9.906	74.000	6.428	PK
2			5460.000	62.563	56.077	-11.437	74.000	6.486	PK
3			5468.385	64.793	58.274	-3.407	68.200	6.519	PK
4			5470.000	62.029	55.504	-6.171	68.200	6.524	PK
5		*	5495.070	112.148	105.654	N/A	N/A	6.494	PK

Note: Measure Level (dB μ V/m) = Reading Level (dB μ V) + Factor (dB)

Factor (dB) = Cable Loss (dB) + Antenna Factor (dB/m) - Pre_Amplifier Gain (dB)

Site: WZ-AC2	Time: 2020/09/09 - 20:52
Limit: FCC_Part15.209_RE(3m)	Engineer: Antony Yang
Probe: AC1_BBHA9120D_1-18GHz	Polarity: Horizontal
EUT: GPON ONT	Power: AC 120V/60Hz
Test Mode: Transmit by 802.11a at channel 5500MHz (CDD Mode)	

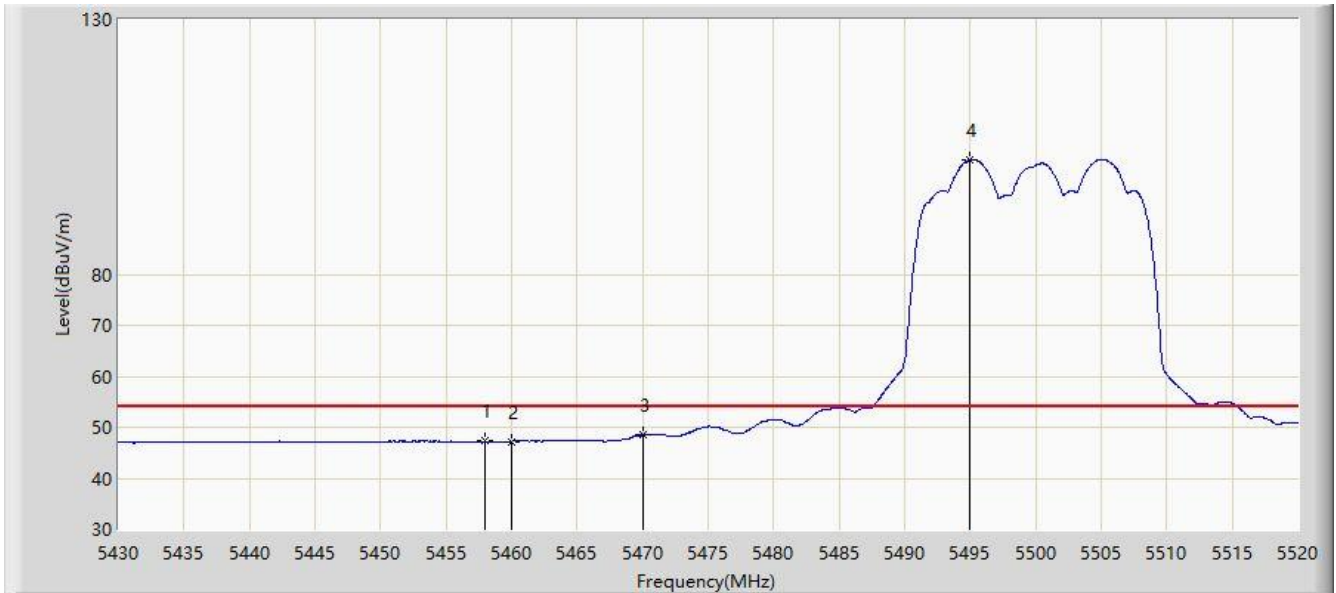

No	Flag	Mark	Frequency (MHz)	Measure Level (dBuV/m)	Reading Level (dBuV)	Margin (dB)	Limit (dBuV/m)	Factor (dB)	Type
1			5457.990	47.259	40.781	-6.741	54.000	6.477	AV
2			5460.000	47.219	40.733	-6.781	54.000	6.486	AV
3			5470.000	48.466	41.941	-5.534	54.000	6.524	AV
4		*	5494.980	102.521	96.027	N/A	N/A	6.494	AV

Note: Measure Level (dB μ V/m) = Reading Level (dB μ V) + Factor (dB)

Factor (dB) = Cable Loss (dB) + Antenna Factor (dB/m) - Pre_Amplifier Gain (dB)

Site: WZ-AC2	Time: 2020/09/09 - 20:55
Limit: FCC_Part15.209_RE(3m)	Engineer: Antony Yang
Probe: AC1_BBHA9120D_1-18GHz	Polarity: Vertical
EUT: GPON ONT	Power: AC 120V/60Hz
Test Mode: Transmit by 802.11a at channel 5500MHz (CDD Mode)	

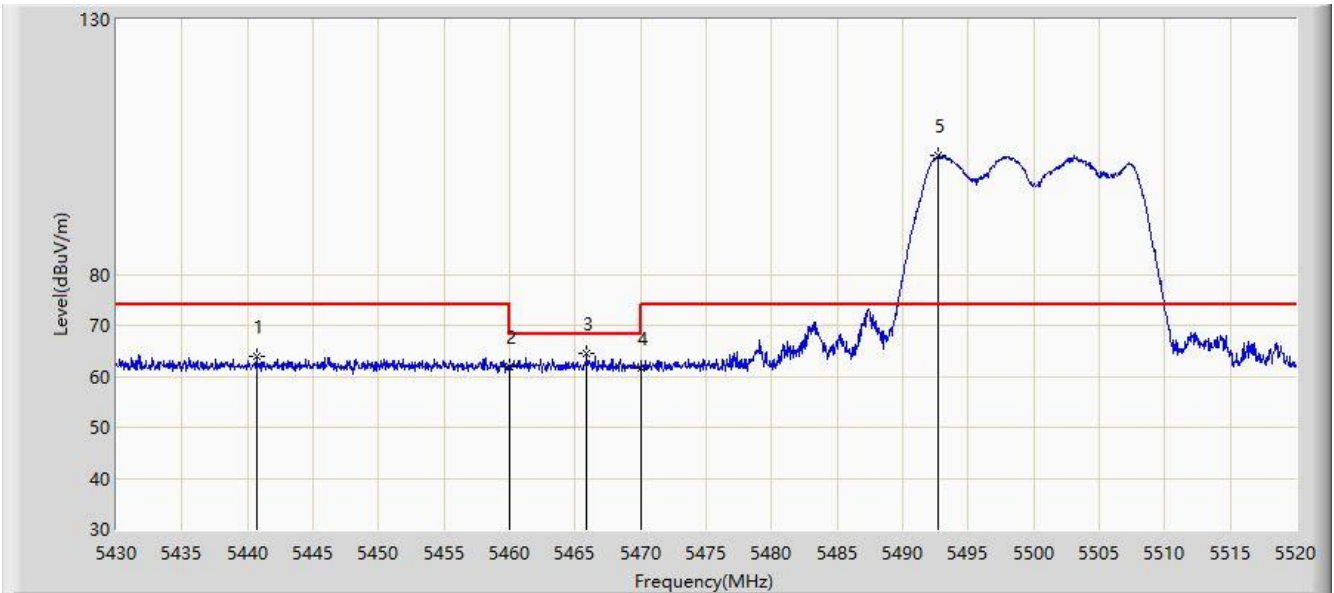

No	Flag	Mark	Frequency (MHz)	Measure Level (dBuV/m)	Reading Level (dBuV)	Margin (dB)	Limit (dBuV/m)	Factor (dB)	Type
1			5440.665	63.823	57.392	-10.177	74.000	6.430	PK
2			5460.000	61.940	55.454	-12.060	74.000	6.486	PK
3			5465.865	64.379	57.870	-3.821	68.200	6.509	PK
4			5470.000	61.631	55.106	-6.569	68.200	6.524	PK
5		*	5492.730	103.375	96.891	N/A	N/A	6.485	PK

Note: Measure Level (dB μ V/m) = Reading Level (dB μ V) + Factor (dB)

Factor (dB) = Cable Loss (dB) + Antenna Factor (dB/m) - Pre_Amplifier Gain (dB)

Site: WZ-AC2	Time: 2020/09/09 - 20:56
Limit: FCC_Part15.209_RE(3m)	Engineer: Antony Yang
Probe: AC1_BBHA9120D_1-18GHz	Polarity: Vertical
EUT: GPON ONT	Power: AC 120V/60Hz
Test Mode: Transmit by 802.11a at channel 5500MHz (CDD Mode)	

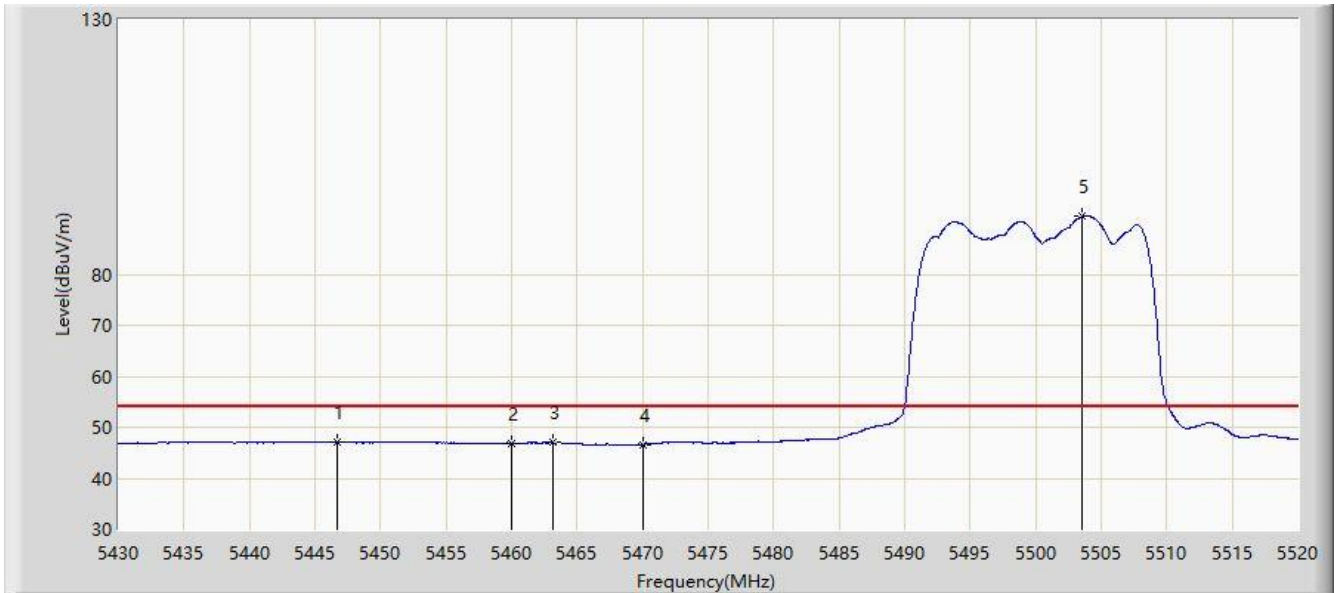

No	Flag	Mark	Frequency (MHz)	Measure Level (dBuV/m)	Reading Level (dBuV)	Margin (dB)	Limit (dBuV/m)	Factor (dB)	Type
1			5446.740	47.013	40.566	-6.987	54.000	6.448	AV
2			5460.000	46.860	40.374	-7.140	54.000	6.486	AV
3			5463.165	47.012	40.514	-6.988	54.000	6.498	AV
4			5470.000	46.587	40.062	-7.413	54.000	6.524	AV
5		*	5503.575	91.373	84.842	N/A	N/A	6.531	AV

Note: Measure Level (dB μ V/m) = Reading Level (dB μ V) + Factor (dB)

Factor (dB) = Cable Loss (dB) + Antenna Factor (dB/m) - Pre_Amplifier Gain (dB)

Site: WZ-AC2	Time: 2020/09/09 - 21:00
Limit: FCC_Part15.209_RE(3m)	Engineer: Antony Yang
Probe: AC1_BBHA9120D_1-18GHz	Polarity: Horizontal
EUT: GPON ONT	Power: AC 120V/60Hz
Test Mode: Transmit by 802.11a at channel 5700MHz (CDD Mode)	

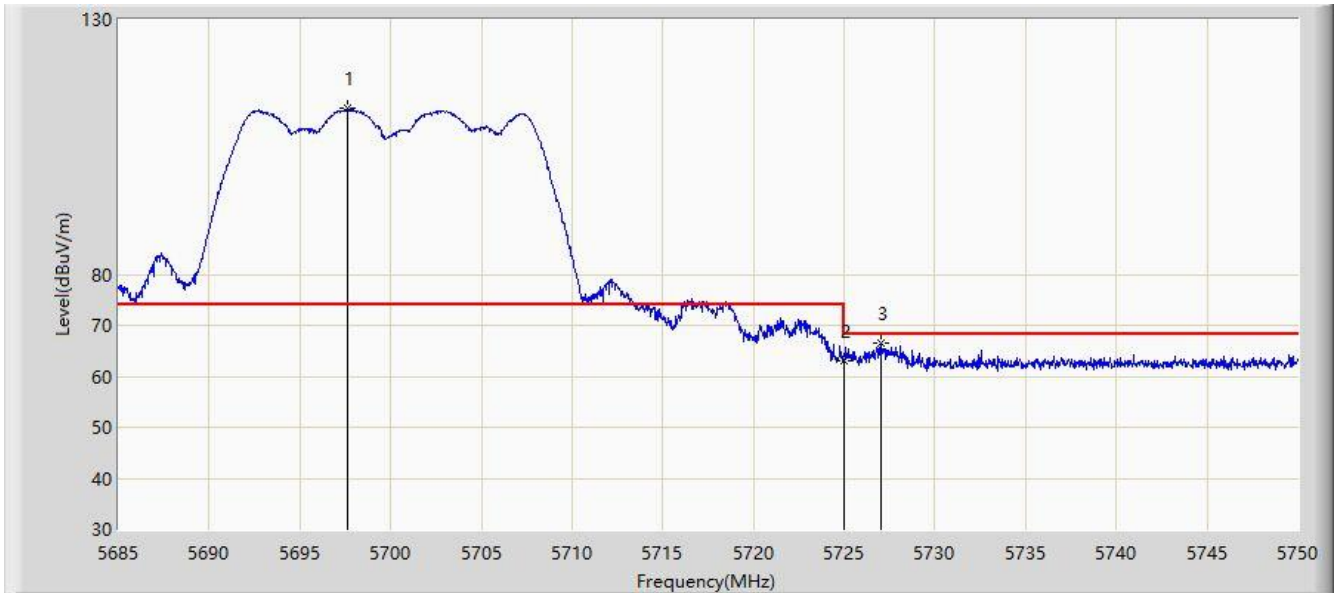

No	Flag	Mark	Frequency (MHz)	Measure Level (dBuV/m)	Reading Level (dBuV)	Margin (dB)	Limit (dBuV/m)	Factor (dB)	Type
1		*	5697.610	112.489	106.080	N/A	N/A	6.410	PK
2			5725.000	63.179	56.755	-5.021	68.200	6.424	PK
3			5726.990	66.641	60.178	-1.559	68.200	6.463	PK

Note: Measure Level (dB μ V/m) = Reading Level (dB μ V) + Factor (dB)

Factor (dB) = Cable Loss (dB) + Antenna Factor (dB/m) - Pre_Amplifier Gain (dB)

Site: WZ-AC2	Time: 2020/09/09 - 21:04
Limit: FCC_Part15.209_RE(3m)	Engineer: Antony Yang
Probe: AC1_BBHA9120D_1-18GHz	Polarity: Vertical
EUT: GPON ONT	Power: AC 120V/60Hz
Test Mode: Transmit by 802.11a at channel 5700MHz (CDD Mode)	

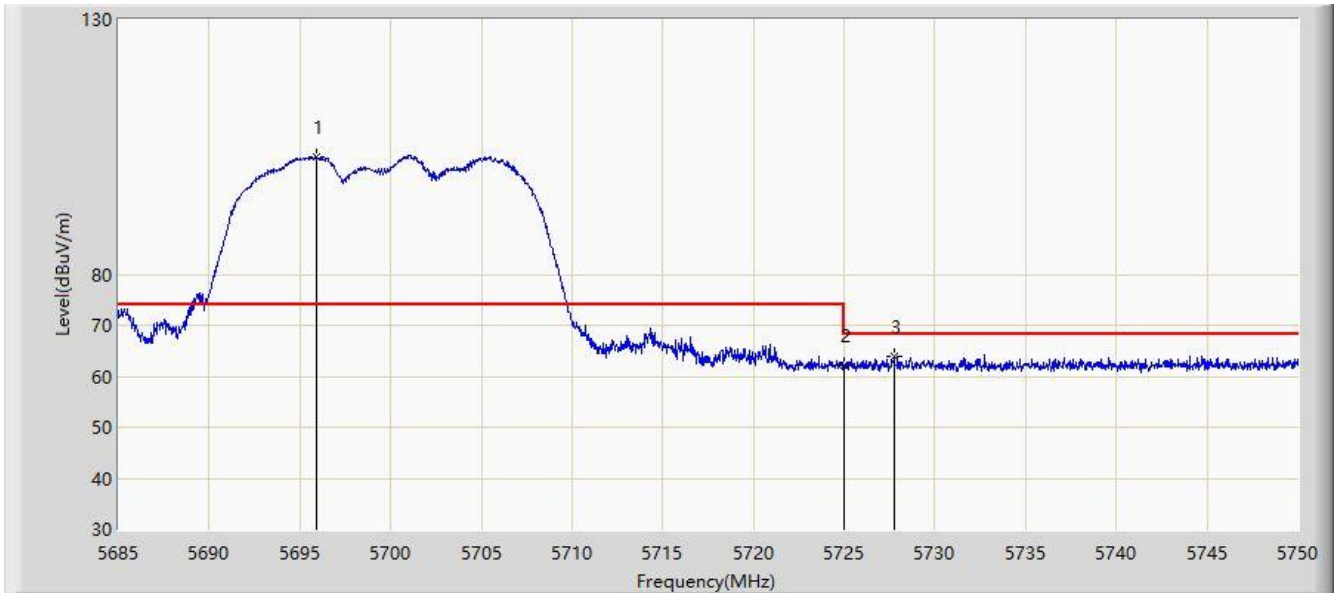

No	Flag	Mark	Frequency (MHz)	Measure Level (dBuV/m)	Reading Level (dBuV)	Margin (dB)	Limit (dBuV/m)	Factor (dB)	Type
1		*	5695.920	103.137	96.740	N/A	N/A	6.397	PK
2			5725.000	62.208	55.784	-5.992	68.200	6.424	PK
3			5727.770	63.792	57.314	-4.408	68.200	6.478	PK

Note: Measure Level (dB μ V/m) = Reading Level (dB μ V) + Factor (dB)

Factor (dB) = Cable Loss (dB) + Antenna Factor (dB/m) - Pre_Amplifier Gain (dB)

Site: WZ-AC2	Time: 2020/09/09 - 21:09
Limit: FCC_Part15.407_RE(3m)	Engineer: Antony Yang
Probe: AC1_BBHA9120D_1-18GHz	Polarity: Horizontal
EUT: GPON ONT	Power: AC 120V/60Hz
Test Mode: Transmit by 802.11a at channel 5745MHz (CDD Mode)	

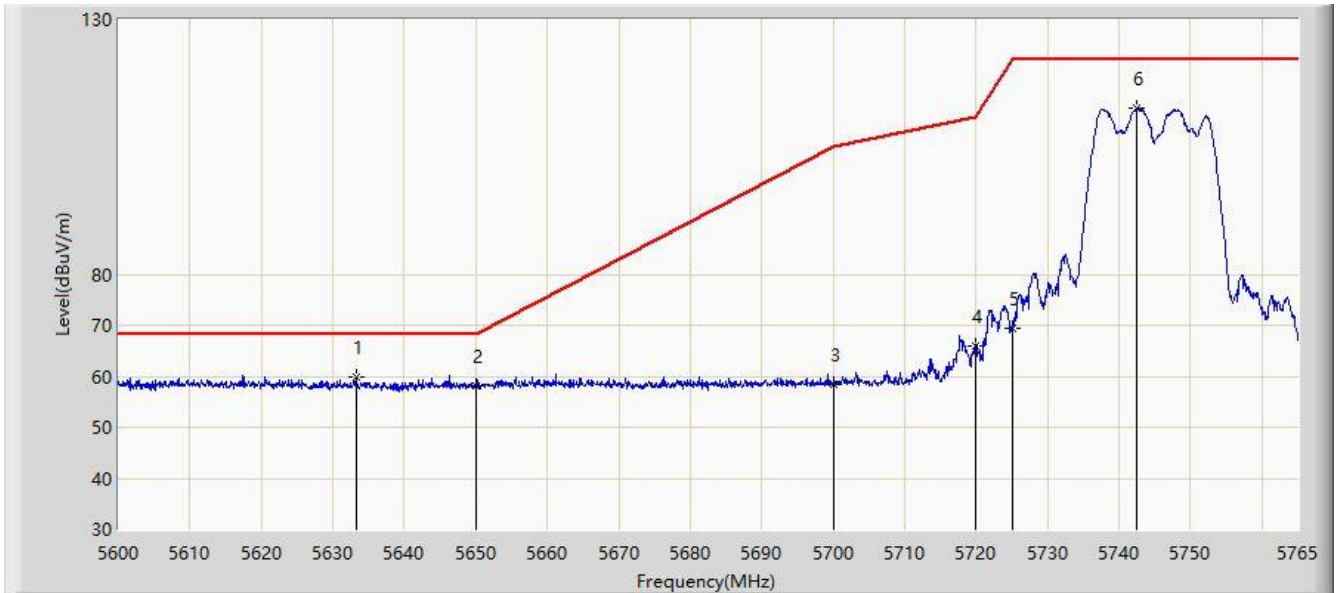

No	Flag	Mark	Frequency (MHz)	Measure Level (dBuV/m)	Reading Level (dBuV)	Margin (dB)	Limit (dBuV/m)	Factor (dB)	Type
1		*	5633.248	59.867	53.819	-8.333	68.200	6.047	PK
2			5650.000	58.037	51.778	-10.163	68.200	6.258	PK
3			5700.000	58.379	51.954	-46.821	105.200	6.426	PK
4			5720.000	65.870	59.485	-44.930	110.800	6.386	PK
5			5725.000	69.293	62.869	-52.907	122.200	6.424	PK
6			5742.560	112.577	105.831	N/A	N/A	6.746	PK

Note: Measure Level (dB μ V/m) = Reading Level (dB μ V) + Factor (dB)

Factor (dB) = Cable Loss (dB) + Antenna Factor (dB/m) - Pre_Amplifier Gain (dB)

Site: WZ-AC2	Time: 2020/09/09 - 21:15
Limit: FCC_Part15.407_RE(3m)	Engineer: Antony Yang
Probe: AC1_BBHA9120D_1-18GHz	Polarity: Vertical
EUT: GPON ONT	Power: AC 120V/60Hz
Test Mode: Transmit by 802.11a at channel 5745MHz (CDD Mode)	

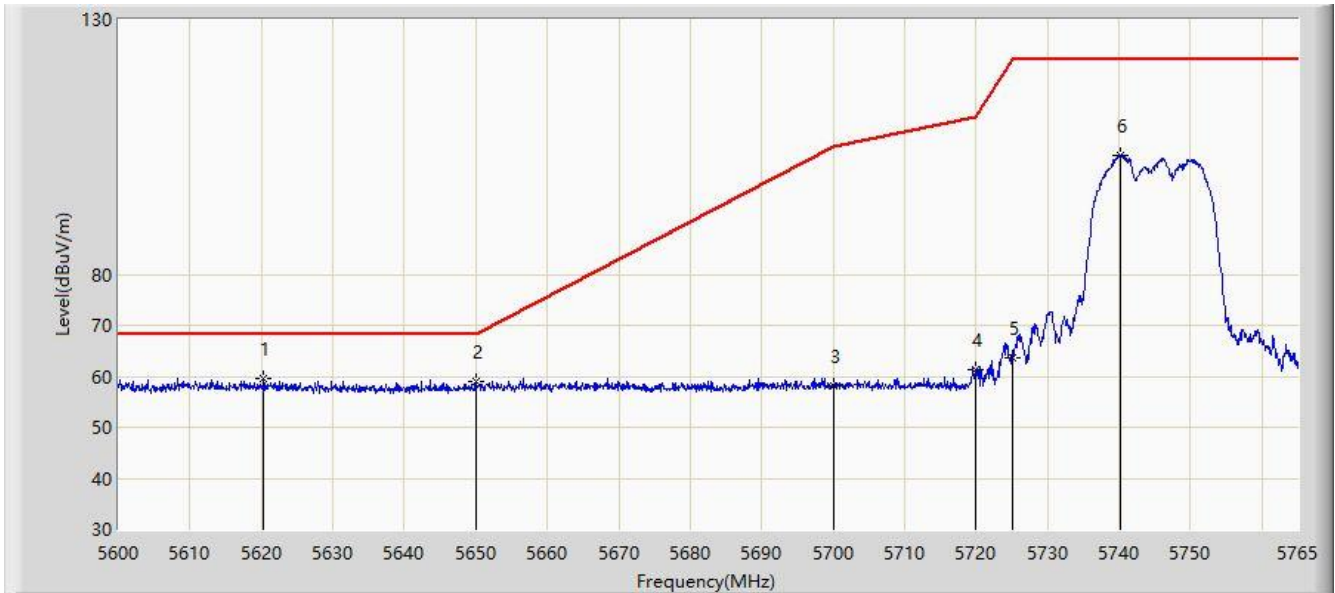

No	Flag	Mark	Frequency (MHz)	Measure Level (dBuV/m)	Reading Level (dBuV)	Margin (dB)	Limit (dBuV/m)	Factor (dB)	Type
1		*	5620.295	59.465	53.078	-8.735	68.200	6.387	PK
2			5650.000	58.911	52.652	-9.289	68.200	6.258	PK
3			5700.000	58.159	51.734	-47.041	105.200	6.426	PK
4			5720.000	61.306	54.921	-49.494	110.800	6.386	PK
5			5725.000	63.626	57.202	-58.574	122.200	6.424	PK
6			5740.085	103.466	96.759	N/A	N/A	6.707	PK

Note: Measure Level (dB μ V/m) = Reading Level (dB μ V) + Factor (dB)

Factor (dB) = Cable Loss (dB) + Antenna Factor (dB/m) - Pre_Amplifier Gain (dB)

Site: WZ-AC2	Time: 2020/09/09 - 21:17
Limit: FCC_Part15.407_RE(3m)	Engineer: Antony Yang
Probe: AC1_BBHA9120D_1-18GHz	Polarity: Horizontal
EUT: GPON ONT	Power: AC 120V/60Hz
Test Mode: Transmit by 802.11a at channel 5825MHz (CDD Mode)	

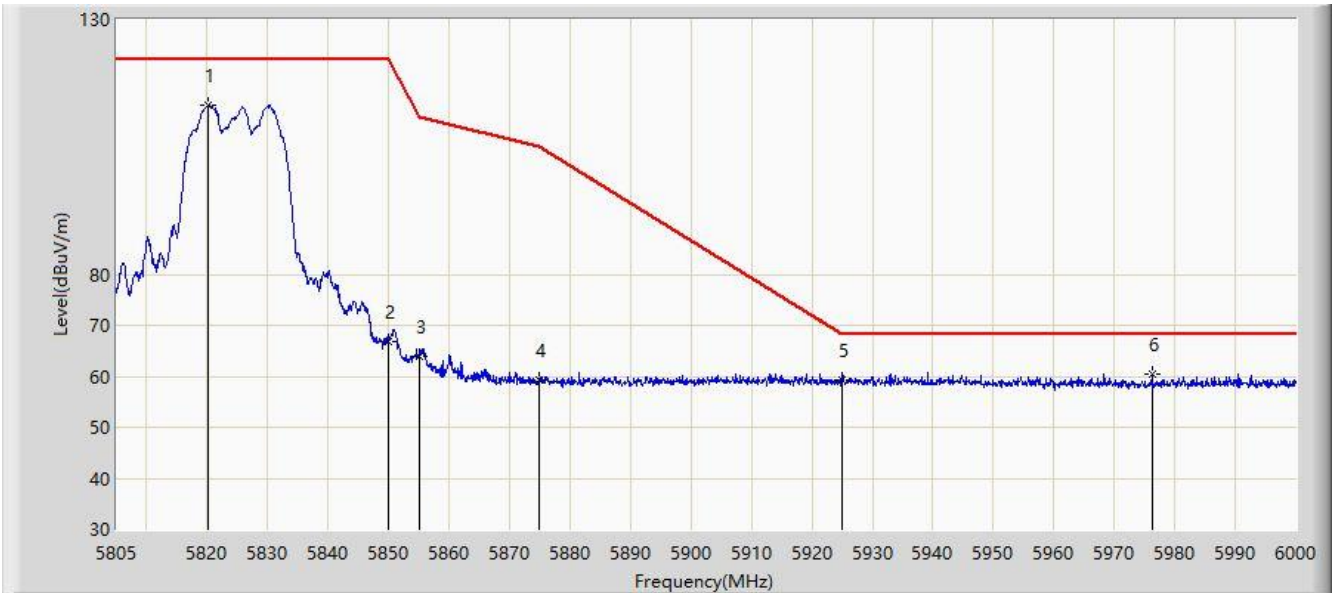

No	Flag	Mark	Frequency (MHz)	Measure Level (dBuV/m)	Reading Level (dBuV)	Margin (dB)	Limit (dBuV/m)	Factor (dB)	Type
1			5820.210	113.080	106.122	N/A	N/A	6.958	PK
2			5850.000	66.868	60.060	-55.332	122.200	6.808	PK
3			5855.000	63.868	57.048	-46.932	110.800	6.820	PK
4			5875.000	59.298	52.380	-45.902	105.200	6.918	PK
5			5925.000	59.132	52.035	-9.068	68.200	7.097	PK
6		*	5976.210	60.436	53.531	-7.764	68.200	6.905	PK

Note: Measure Level (dBμV/m) = Reading Level (dBμV) + Factor (dB)

Factor (dB) = Cable Loss (dB) + Antenna Factor (dB/m) - Pre_Amplifier Gain (dB)

Site: WZ-AC2	Time: 2020/09/09 - 21:19
Limit: FCC_Part15.407_RE(3m)	Engineer: Antony Yang
Probe: AC1_BBHA9120D_1-18GHz	Polarity: Vertical
EUT: GPON ONT	Power: AC 120V/60Hz
Test Mode: Transmit by 802.11a at channel 5825MHz (CDD Mode)	

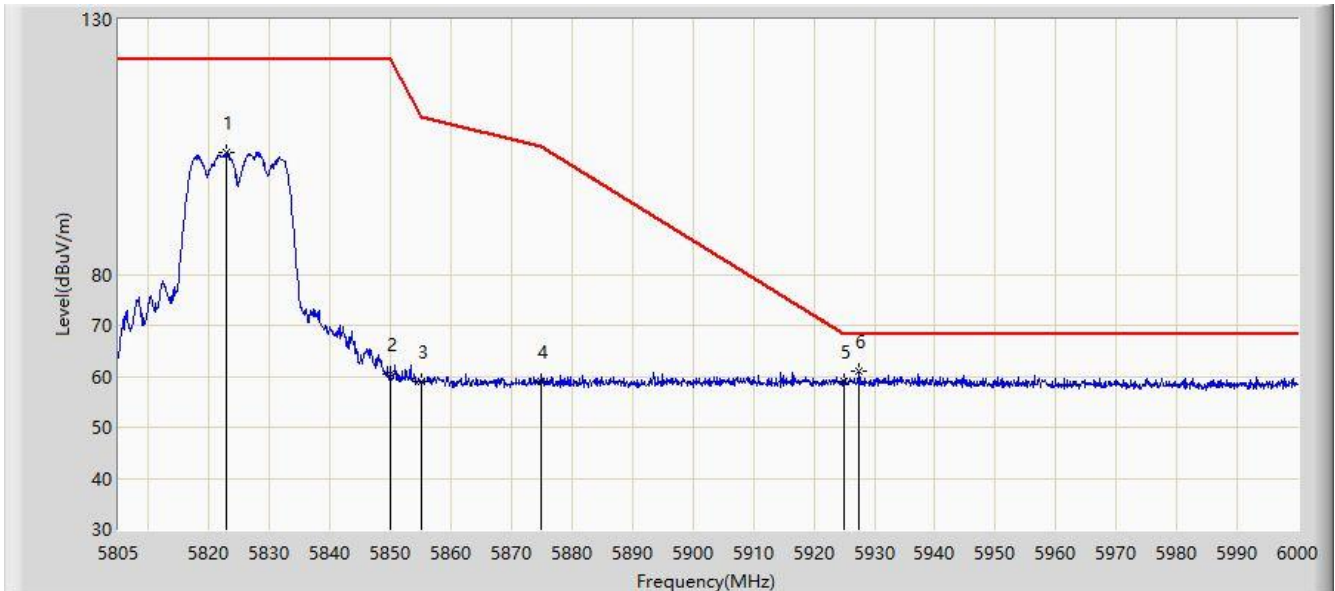

No	Flag	Mark	Frequency (MHz)	Measure Level (dBuV/m)	Reading Level (dBuV)	Margin (dB)	Limit (dBuV/m)	Factor (dB)	Type
1			5822.842	103.866	96.864	N/A	N/A	7.001	PK
2			5850.000	60.572	53.764	-61.628	122.200	6.808	PK
3			5855.000	59.057	52.237	-51.743	110.800	6.820	PK
4			5875.000	59.059	52.141	-46.141	105.200	6.918	PK
5			5925.000	58.925	51.828	-9.275	68.200	7.097	PK
6		*	5927.460	60.872	53.744	-7.328	68.200	7.128	PK

Note: Measure Level (dB μ V/m) = Reading Level (dB μ V) + Factor (dB)

Factor (dB) = Cable Loss (dB) + Antenna Factor (dB/m) - Pre_Amplifier Gain (dB)

Site: WZ-AC2	Time: 2020/09/09 - 21:22
Limit: FCC_Part15.209_RE(3m)	Engineer: Antony Yang
Probe: AC1_BBHA9120D_1-18GHz	Polarity: Horizontal
EUT: GPON ONT	Power: AC 120V/60Hz
Test Mode: Transmit by 802.11n-HT20 at channel 5180MHz (CDD Mode)	

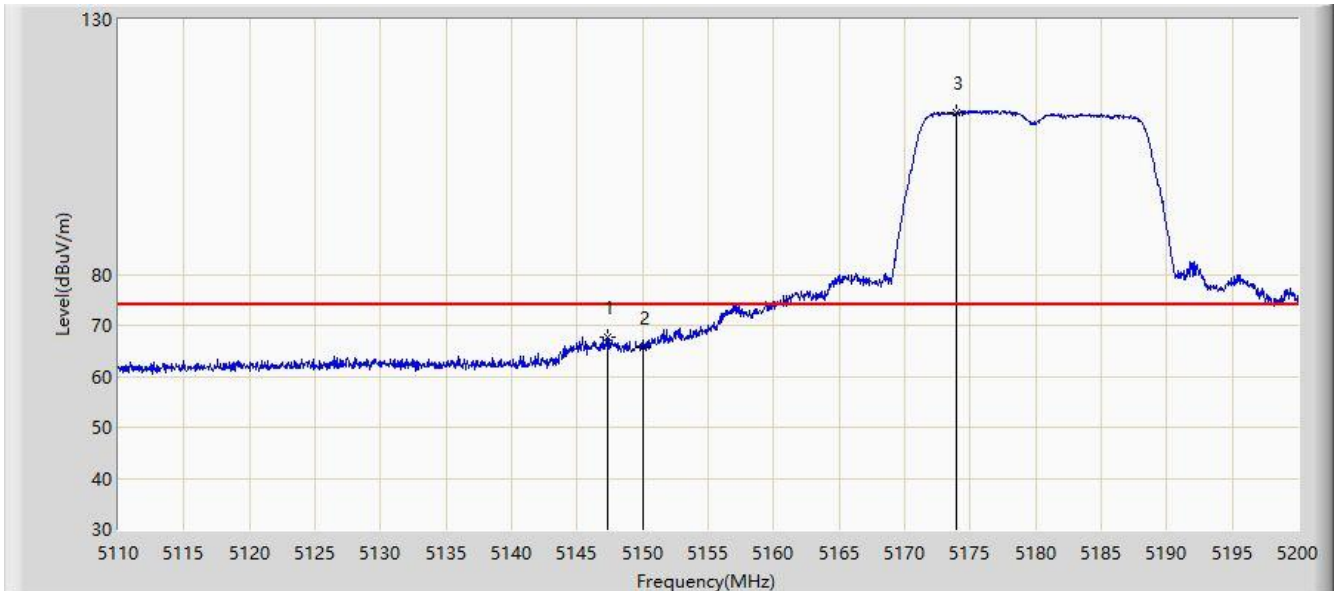

No	Flag	Mark	Frequency (MHz)	Measure Level (dBuV/m)	Reading Level (dBuV)	Margin (dB)	Limit (dBuV/m)	Factor (dB)	Type
1			5147.350	67.799	61.334	-6.201	74.000	6.465	PK
2			5150.000	65.789	59.337	-8.211	74.000	6.452	PK
3		*	5173.990	111.842	105.367	N/A	N/A	6.474	PK

Note: Measure Level (dB μ V/m) = Reading Level (dB μ V) + Factor (dB)

Factor (dB) = Cable Loss (dB) + Antenna Factor (dB/m) - Pre_Amplifier Gain (dB)

Site: WZ-AC2	Time: 2020/09/09 - 21:25
Limit: FCC_Part15.209_RE(3m)	Engineer: Antony Yang
Probe: AC1_BBHA9120D_1-18GHz	Polarity: Horizontal
EUT: GPON ONT	Power: AC 120V/60Hz
Test Mode: Transmit by 802.11n-HT20 at channel 5180MHz (CDD Mode)	

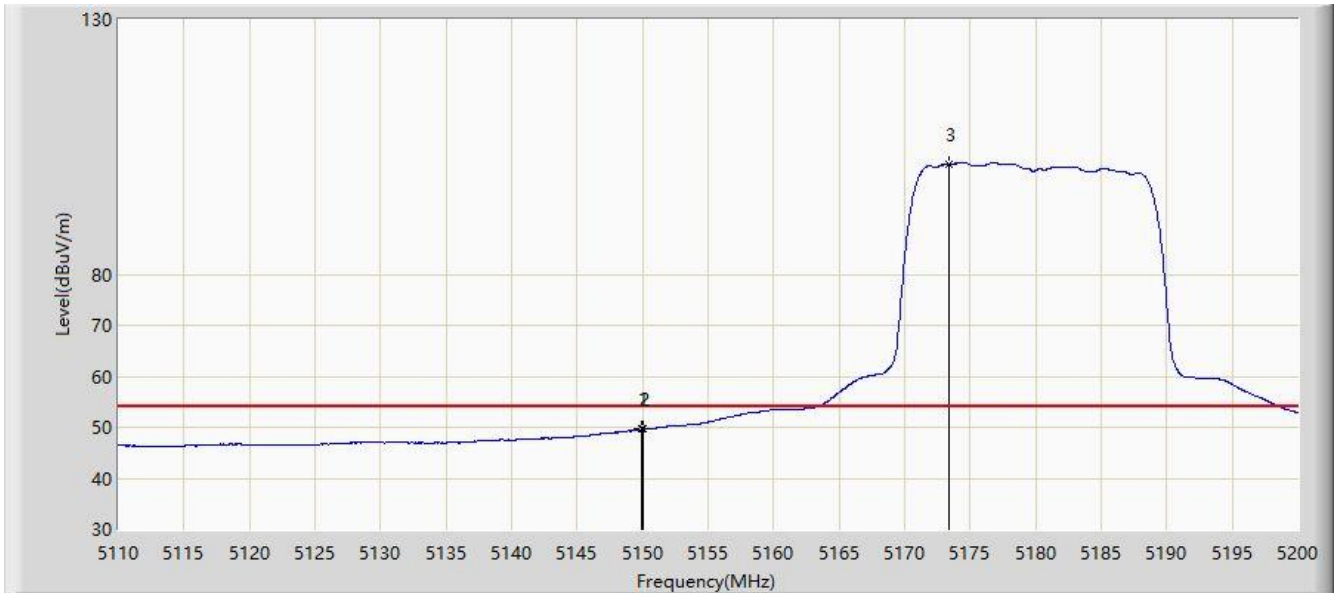

No	Flag	Mark	Frequency (MHz)	Measure Level (dBuV/m)	Reading Level (dBuV)	Margin (dB)	Limit (dBuV/m)	Factor (dB)	Type
1			5149.960	49.608	43.156	-4.392	54.000	6.452	AV
2			5150.000	49.603	43.151	-4.397	54.000	6.452	AV
3		*	5173.405	101.585	95.114	N/A	N/A	6.471	AV

Note: Measure Level (dB μ V/m) = Reading Level (dB μ V) + Factor (dB)

Factor (dB) = Cable Loss (dB) + Antenna Factor (dB/m) - Pre_Amplifier Gain (dB)

Site: WZ-AC2	Time: 2020/09/09 - 21:28
Limit: FCC_Part15.209_RE(3m)	Engineer: Antony Yang
Probe: AC1_BBHA9120D_1-18GHz	Polarity: Vertical
EUT: GPON ONT	Power: AC 120V/60Hz
Test Mode: Transmit by 802.11n-HT20 at channel 5180MHz (CDD Mode)	

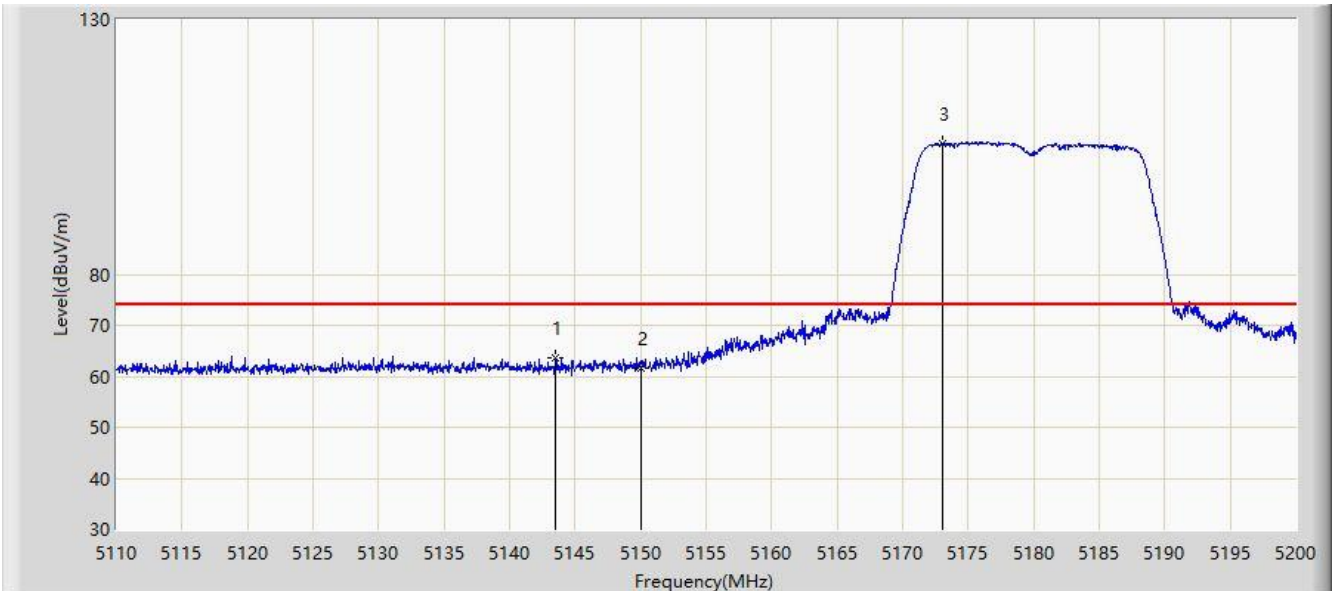

No	Flag	Mark	Frequency (MHz)	Measure Level (dBuV/m)	Reading Level (dBuV)	Margin (dB)	Limit (dBuV/m)	Factor (dB)	Type
1			5143.480	63.684	57.151	-10.316	74.000	6.534	PK
2			5150.000	61.673	55.221	-12.327	74.000	6.452	PK
3		*	5173.000	105.644	99.176	N/A	N/A	6.468	PK

Note: Measure Level (dB μ V/m) = Reading Level (dB μ V) + Factor (dB)

Factor (dB) = Cable Loss (dB) + Antenna Factor (dB/m) - Pre_Amplifier Gain (dB)

Site: WZ-AC2	Time: 2020/09/09 - 21:29
Limit: FCC_Part15.209_RE(3m)	Engineer: Antony Yang
Probe: AC1_BBHA9120D_1-18GHz	Polarity: Vertical
EUT: GPON ONT	Power: AC 120V/60Hz
Test Mode: Transmit by 802.11n-HT20 at channel 5180MHz (CDD Mode)	

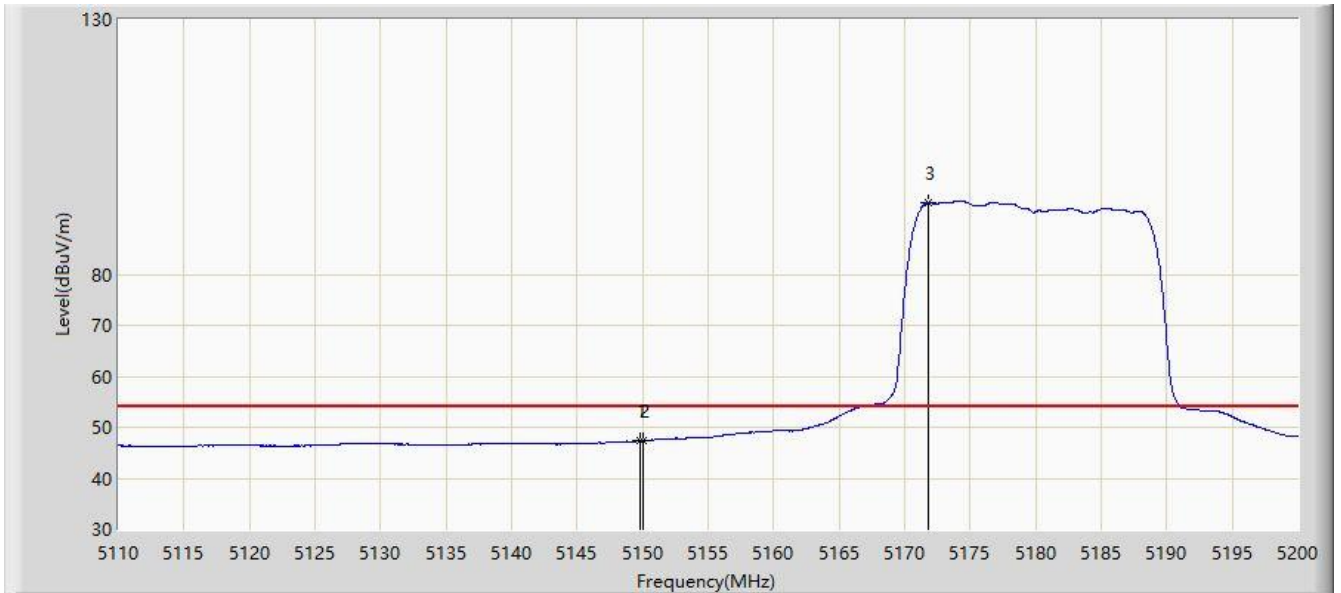

No	Flag	Mark	Frequency (MHz)	Measure Level (dBuV/m)	Reading Level (dBuV)	Margin (dB)	Limit (dBuV/m)	Factor (dB)	Type
1			5149.825	47.389	40.937	-6.611	54.000	6.452	AV
2			5150.000	47.326	40.874	-6.674	54.000	6.452	AV
3		*	5171.830	94.136	87.676	N/A	N/A	6.460	AV

Note: Measure Level (dB μ V/m) = Reading Level (dB μ V) + Factor (dB)

Factor (dB) = Cable Loss (dB) + Antenna Factor (dB/m) - Pre_Amplifier Gain (dB)

Site: WZ-AC2	Time: 2020/09/09 - 21:32
Limit: FCC_Part15.209_RE(3m)	Engineer: Antony Yang
Probe: AC1_BBHA9120D_1-18GHz	Polarity: Horizontal
EUT: GPON ONT	Power: AC 120V/60Hz
Test Mode: Transmit by 802.11n-HT20 at channel 5240MHz (CDD Mode)	

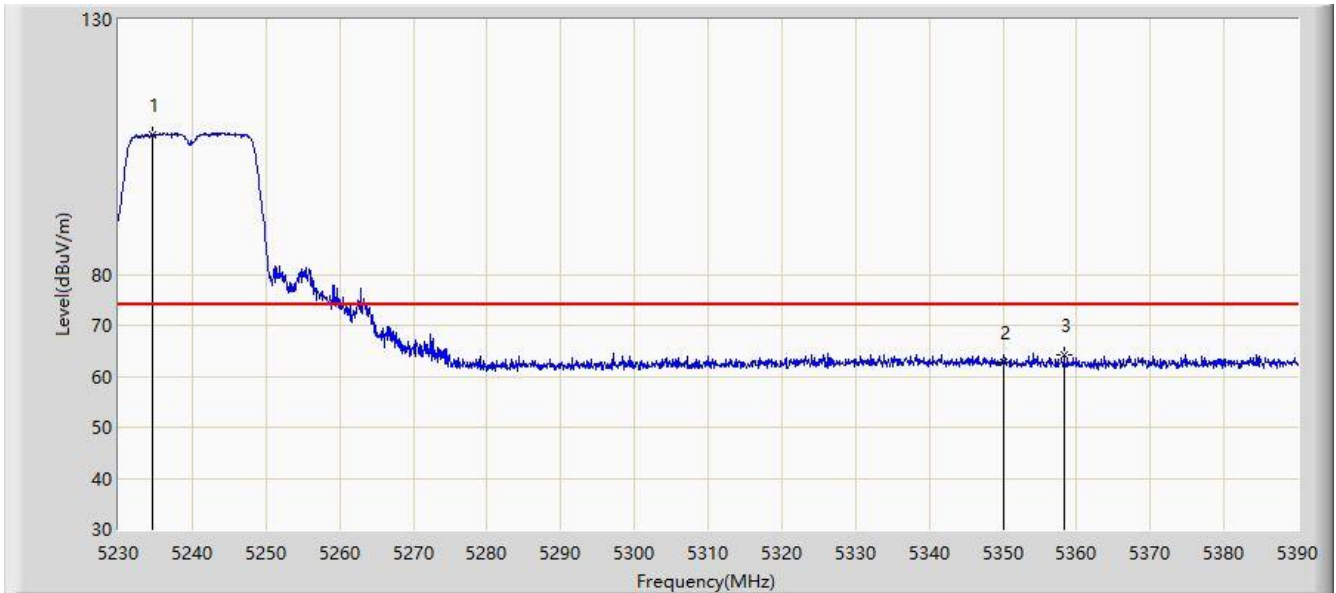

No	Flag	Mark	Frequency (MHz)	Measure Level (dBuV/m)	Reading Level (dBuV)	Margin (dB)	Limit (dBuV/m)	Factor (dB)	Type
1		*	5234.640	107.507	101.401	N/A	N/A	6.106	PK
2			5350.000	62.711	56.253	-11.289	74.000	6.458	PK
3			5358.320	64.072	57.841	-9.928	74.000	6.231	PK

Note: Measure Level (dB μ V/m) = Reading Level (dB μ V) + Factor (dB)

Factor (dB) = Cable Loss (dB) + Antenna Factor (dB/m) - Pre_Amplifier Gain (dB)

Site: WZ-AC2	Time: 2020/09/09 - 21:36
Limit: FCC_Part15.209_RE(3m)	Engineer: Antony Yang
Probe: AC1_BBHA9120D_1-18GHz	Polarity: Horizontal
EUT: GPON ONT	Power: AC 120V/60Hz
Test Mode: Transmit by 802.11n-HT20 at channel 5240MHz (CDD Mode)	

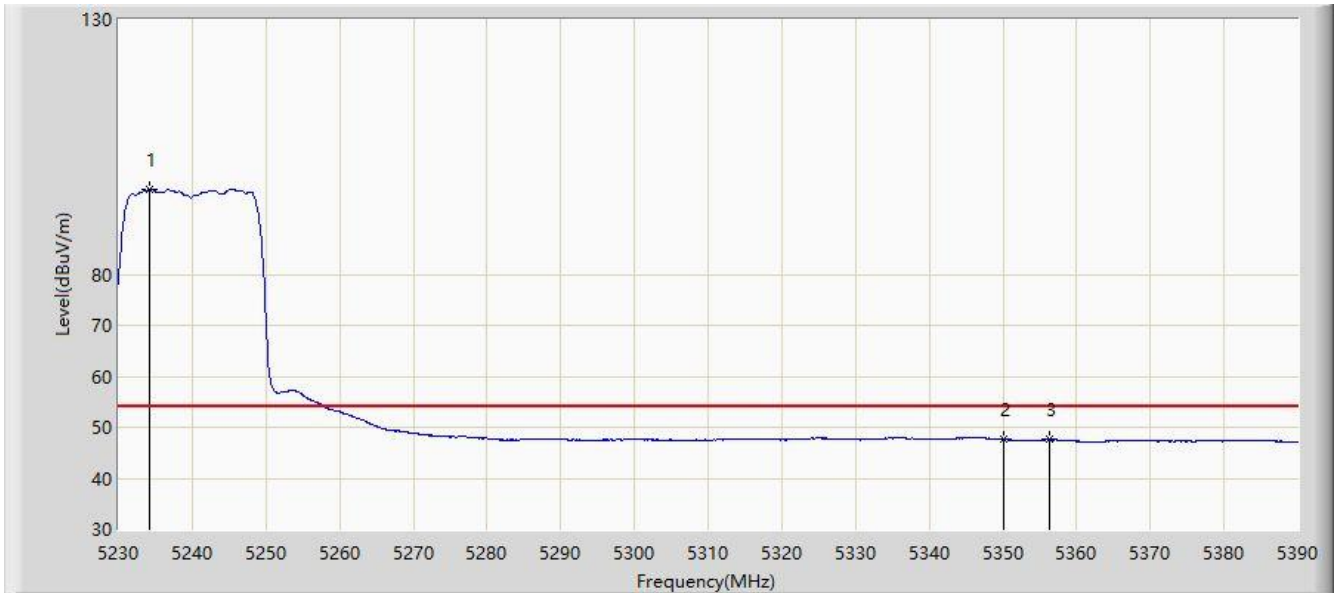

No	Flag	Mark	Frequency (MHz)	Measure Level (dBuV/m)	Reading Level (dBuV)	Margin (dB)	Limit (dBuV/m)	Factor (dB)	Type
1		*	5234.160	96.627	90.517	N/A	N/A	6.110	AV
2			5350.000	47.556	41.098	-6.444	54.000	6.458	AV
3			5356.240	47.653	41.368	-6.347	54.000	6.285	AV

Note: Measure Level (dB μ V/m) = Reading Level (dB μ V) + Factor (dB)

Factor (dB) = Cable Loss (dB) + Antenna Factor (dB/m) - Pre_Amplifier Gain (dB)