



Text Part Number: 78-6030-01

Cisco uBR7200 Series Universal Broadband Router Wireless Modem Card and Subsystem Installation and Configuration

Product Numbers: UBR-MCW-PDA, UBR-MCW-PDA=, UBR-WPFD, UBR-WPFD=, UBR-ODU-PAA, UR-ODU-PAA=, UBR-ODD-01A, UBR-ODD-01A=, UBR-ODD-02A, UBR-ODD-02A=, UBR-ODD-03A, UBR-ODD-03A=

This document explains how to install and configure the components for a high-speed point-to-point fixed broadband wireless system using Cisco uBR7200 series universal broadband routers. It includes instructions for installing a wireless modem card, power feed panel, and outdoor unit, as well as instructions for configuring and verifying the system and troubleshooting the configuration.

The Cisco uBR7200 series consists of the 6-slot Cisco uBR7246 (four modem card slots and two port adapter slots) and the 3-slot Cisco uBR7223 (two modem card slots and one port adapter slot).

Note Use this configuration note in conjunction with the *Cisco uBR7200 Series Universal Broadband Router Installation and Configuration Guide* and *Regulatory Compliance and Safety Information for the Cisco uBR7200 Series Universal Broadband Router* that shipped with your Cisco uBR7200 series router, and the *Cisco Wireless Broadband Router Site Planning Guide*

The following sections are included in this document:

- If You Need More Information, page 2
- Wireless Modem Card and Subsystem Overview, page 2
- Installation Prerequisites, page 7
- Removing and Installing a Wireless Modem Card, page 12
- Installing a Power Feed Panel, page 16
- Installing an Outdoor Unit, page 21
- Configuring a Wireless Modem Card, page 25
- Using the Debug Commands, page 84
- Reference Information, page 88

Corporate Headquarters

Cisco Systems, Inc.
170 West Tasman Drive
San Jose, CA 95134-1706
USA

Copyright © 1999
Cisco Systems, Inc.
All rights reserved.

If You Need More Information

- Cisco Connection Online, page 88

If You Need More Information

The Cisco IOS software running on your router contains extensive features and functionality. The effective use of many of these features is easier if you have more information. For additional information on configuring and maintaining the Cisco uBR7200 series, the following documentation resources are available:

- Cisco Documentation CD-ROM

Cisco documentation and additional literature are available in a CD-ROM package, which ships with your product. The Documentation CD-ROM, a member of the Cisco Connection Family, is updated monthly. Therefore, it might be more current than printed documentation. To order additional copies of the Documentation CD-ROM, contact your local sales representative or call customer service. The CD-ROM package is available as a single package or as an annual subscription. You can also access Cisco documentation on the World Wide Web at <http://www.cisco.com>, <http://www-china.cisco.com>, or <http://www-europe.cisco.com>.

If you are reading Cisco product documentation on the World Wide Web, you can submit comments electronically. Click **Feedback** in the toolbar and select **Documentation**. After you complete the form, click **Submit** to send it to Cisco. We appreciate your comments.

- For Cisco IOS software configuration information, refer to the modular configuration and modular command reference publications in the Cisco IOS software configuration documentation set that corresponds to the software release installed on your Cisco hardware.

Note You can access Cisco IOS software configuration documentation on the World Wide Web at <http://www.cisco.com>, <http://www-china.cisco.com>, <http://www-europe.cisco.com>.

- For hardware installation and maintenance information on the Cisco uBR7200 series, refer to the *Cisco uBR7200 Series Universal Broadband Router Installation and Configuration Guide* that shipped with your Cisco uBR7246 or Cisco uBR7223.
- For international agency compliance, safety, and statutory information for wide-area network (WAN) interfaces for the Cisco uBR7200 series, refer to the document *Regulatory Compliance and Safety Information for the Cisco uBR7200 Series Universal Broadband Router*.
- To obtain general information about documentation, refer to the "Cisco Connection Online" section on page, or call customer service at 800 553-6387 or 408 526-7208. Customer service hours are 5:00 a.m. to 6:00 p.m. Pacific time, Monday through Friday (excluding Cisco-observed holidays). You can also send e-mail to cs-rep@cisco.com, or you can refer to the *Cisco Information Packet* that shipped with your router.

Wireless Modem Card and Subsystem Overview

The Cisco high-speed point-to-point fixed broadband wireless router system provides a fixed, dedicated wireless link from one site to another. This link delivers 44 Mbps full-duplex data in a 12 MHz RF channel in the MDS band (2.500 to 2.690 GHz).

This broadband wireless router system consists of a Cisco uBR7200 Series Universal Broadband Router (Cisco uBR7246, or Cisco uBR7223) and one or more wireless modem cards (Figure 1), each with a power feed panel (Figure 2), and outdoor unit (ODU) (Figure 3). The diversity option uses two outdoor units, one for each of two antennas.

Wireless Modem Card

The wireless modem card provides the control and data interface to the system's digital motherboard and the radio frequency (RF) subsystem in the ODU. It also provides the up/down conversion from baseband to intermediate frequency (IF).

Wireless modem cards consist of the following components:

- Main and diversity serial interface control connectors.
- 10 MHz external reference clock connection.
- Monitor and Power Feed Panel connectors (Main and Diversity)
- Light-emitting diodes (LEDs) which provide a visual indication of the state of the modem card, as well as providing a mechanism by which specific condition can be easily noted.

Note The appearance and meaning of these LEDs can be displayed or modified using the **show interface** and **led** commands. These commands are described in the section "Configuring a Wireless Modem Card" on

Figure 4 shows the connectors and LEDs on the wireless modem card. Table 1 describes the functions of the connectors, and Table 2 describes the functions of the LEDs.

Figure 4 Wireless Modem Card Connectors and LEDs

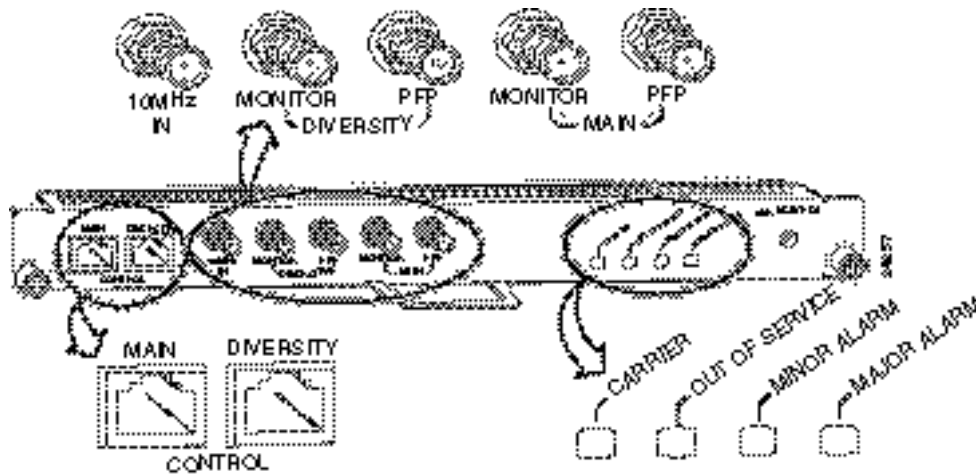

Table 1 Wireless Modem Card Connectors

Connector	Type	Function
Control - Main	8-pin RJ45 (female)	Physical connection to Power Feed Panel for RF subsystem interface control channel.
Control - Diversity	8-pin RJ45 (female)	Physical connection to Power Feed Panel for RF subsystem interface control channel (when diversity option is used).
10 MHz Input	SMA (male)	Connection for 10 MHz external reference clock.
Diversity - Monitor	SMA (female)	For connection to spectrum analyzer for test/troubleshooting purposes (when diversity option is used).

Table 1 Wireless Modem Card Connectors (continued)

Connector	Type	Function
Diversity - PFP	SMA (female)	48 MHz reference, receive and transmit IF signals (when diversity option is used).
Main - Monitor	SMA (female)	For connection to spectrum analyzer for test/troubleshooting purposes.
Main - PFP	SMA (female)	48 MHz reference, receive and transmit IF signals.

Table 2 Wireless Modem Card LEDs

LED	Function
Carrier LED	Indicates the state of the radio link. When lit, the radio link is up.
Out of Service LED	Indicates the service availability of the radio link. When lit, the radio link is still up, but not available for use.
Minor Alarm LED	When lit, indicates the occurrence of a minor alarm in the radio subsystem. The link is degraded and may need maintenance action.
Major Alarm LED	When lit, indicates the occurrence of a major alarm in the radio subsystem. The link is down.

Power Feed Panel

The power feed panel provides DC power and Tx/Rx and reference signals to the ODU. In addition, the unit contains circuit breakers and secondary lightning protection circuitry for both the IF and control cables.

The power feed panel consists of the following components:

- Power LEDs on front and rear panel
- Connector ports
 - Coaxial cable connection to the wireless modem card and ODU (Main and Diversity)
 - Control cable connection ports to modem card and ODU (Main and Diversity)
- Power ON/OFF switches (Main and Diversity)
- DC power supply terminal block

Figure 5 shows the front panel and Figure 6 shows the rear panel of the power feed panel. Table 3 describes the functions of the LEDs. Table 4 describes the functions of the connectors.

Figure 5 Power Feed Panel (Front Panel)



ALPHA DRAFT - CISCO CONFIDENTIAL

Wireless Modem Card and Subsystem Overview

Table 3 Power Feed Panel LEDs

LED	Function
Main Power On (visible on front and rear panel)	When lit, indicates that there is power going to the main ODU.
Diversity Power On (visible on front and rear panel)	When lit, indicates that there is power going to the diversity ODU.

Figure 6 Power Feed Panel (Rear Panel)

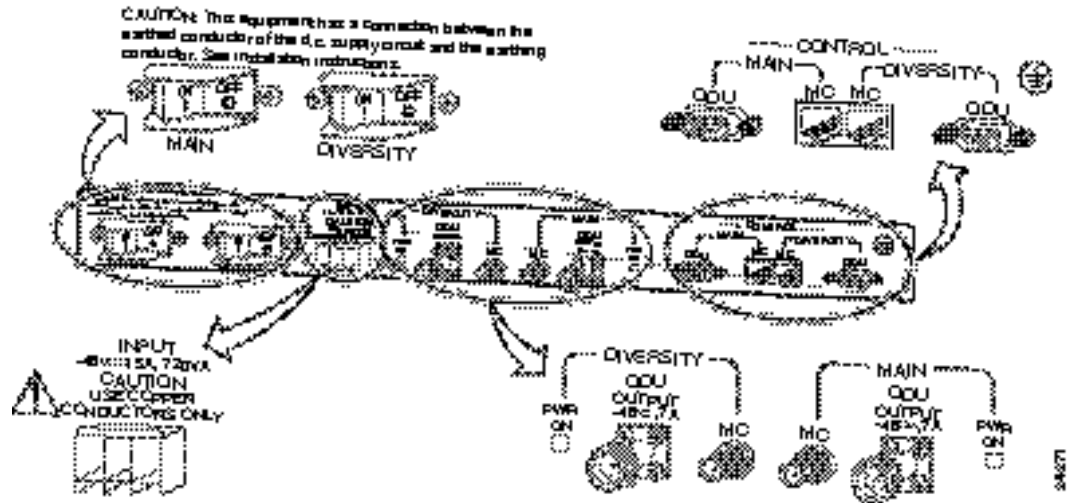

Table 4 Power Feed Panel Connectors

Connector	Type	Function
Main ODU Control	DB9 (female)	Physical connection to the main ODU for RF subsystem interface.
Main MC (modem card) Control	8-pin RJ45 (female)	Physical connection for RF subsystem interface from modem card.
Diversity ODU Control	DB9 (female)	Physical connection to the diversity ODU for RF subsystem interface.
Diversity MC (modem card) Control	8-pin RJ45 (female)	Physical connection for RF subsystem interface from modem card (if diversity option used).
Diversity ODU Output	N-Type (female)	Provides signal and power to the diversity ODU.
Diversity MC (modem card)	SMA (female)	48 MHz reference, receive and transmit IF signals from the modem card (if diversity option used).
Main ODU Output	N-Type (female)	Provides signal and power to the main ODU.
Main MC (modem card)	SMA (female)	48 MHz reference, receive and transmit IF signals from the modem card.
DC Power Input	Pluggable terminal block	Power source for the main and diversity ODUs.

Outdoor Unit (ODU)

The ruggedized ODU is the control and data interface to the indoor subsystems. It provides up/down conversion from IF to RF frequencies and power amplification.

The outdoor unit consists of the following components:

- RF head
- Connector ports for IF input, control, and test
- Duplexor assembly with antenna connection

Figure 7 shows the connectors on the outdoor subsystem, and Table 5 describes their use.

Figure 7 Outdoor Unit Connectors

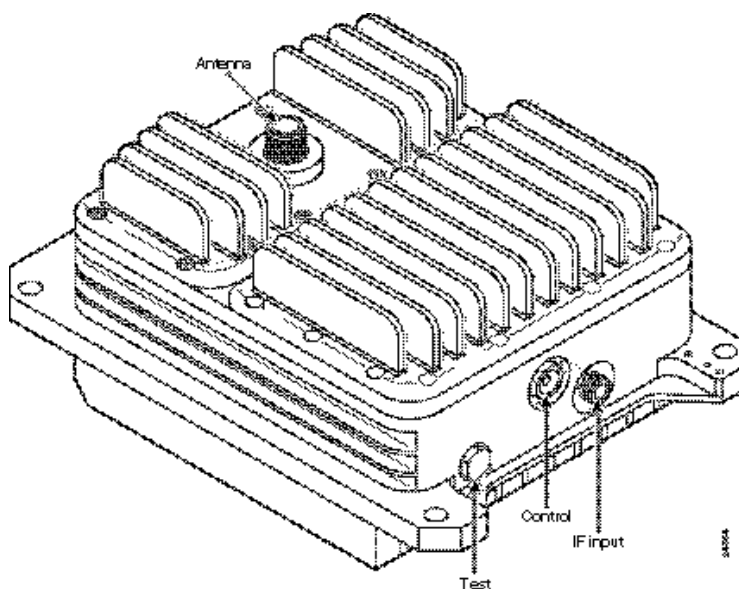

Table 5 Outdoor Unit Connectors

Connector	Type	Function
Antenna connector	N-type weatherized (female)	Antenna connection
IF Input	N-type weatherized (female)	Carries receive and transmit IF signals and power
Control	Lemo	RF subsystem interface
Test	Phono (female)	Antenna alignment

Installation Prerequisites

This section provides a list of parts and tools you need to remove and replace a wireless modem card in the Cisco uBR7200 series router, install the power feed panel in an equipment rack or on the wall, and install the outdoor unit at the antenna site. This section also includes safety and ESD-prevention guidelines to help you avoid injury to yourself and damage to the equipment.

Parts and Tools

The following sections describe the parts and tools required to install each of the components. If you need more detailed information regarding cables or connectors, refer to the *Cisco Wireless Broadband Router Site Planning Guide*.

Wireless Modem Card

You need the following tools and parts to remove and replace a wireless modem card. If you need additional equipment, contact a service representative for ordering information.

- New wireless modem card
- No. 2 Phillips screwdriver
- 5/16 in. open end wrench
- Your own ESD-prevention equipment or the disposable grounding wrist strap included with all upgrade kits, FRUs, and spares
- Antistatic mat or surface
- Static shielding bag
- Cable with RJ45 connectors and coaxial cable with SMA connectors for connections between the modem card and the power feed panel. (Standard sets of these cables can be purchased from Cisco.)
- SMA (male) to BNC (male) adapter cable and coaxial cable for cabling the 10 MHz clock.

Power Feed Panel

You need the following tools and parts to install the power feed panel in an equipment rack. If you need additional equipment, contact a service representative for ordering information.

- Power feed panel
- No. 2 Phillips screwdriver
- Bracket kit (provided)
- Rack mount or wall mount screws
- 1/8 in. blade screwdriver
- 5/16 in. open end wrench
- Cables with N-type (male) connectors for IF control
- Cables with DB9 (male) and Lemo (male) connectors (Lemo connector provided)
- 48VDC power supply

Outdoor Unit

You need the following tools and parts to install the outdoor unit. If you need additional equipment, contact a service representative for ordering information.

- Outdoor unit
- Duplexor assembly
- No. 2 Phillips screwdriver

- Mounting kit (provided)
- Cable with N-type (male) connectors to cable the ODU to the antenna
- Mini-phone with 3.5 mm mono phone plug to use for antenna alignment tasks

Software and Hardware Requirements

The following hardware is required:

- Configured Cisco uBR7200 series router

The following software is required:

- The Cisco uBR7200 series router must be running Cisco IOS Release 12.0(6)XA or later.

Safety Guidelines

Following are safety guidelines that you should follow when working with any equipment that connects to electrical power or telephone wiring.

Safety Warnings



Warning This warning symbol means *danger*. You are in a situation that could cause bodily injury. Before you work on any equipment, be aware of the hazards involved with electrical circuitry and be familiar with standard practices for preventing accidents. To see translations of the warnings that appear in this publication, refer to the *Regulatory Compliance and Safety Information* document that accompanied this device.

Waarschuwing Dit waarschuwingssymbool betekent gevaar. U verkeert in een situatie die lichamelijk letsel kan veroorzaken. Voordat u aan enige apparatuur gaat werken, dient u zich bewust te zijn van de bij elektrische schakelingen betrokken risico's en dient u op de hoogte te zijn van standaard maatregelen om ongelukken te voorkomen. Voor vertalingen van de waarschuwingen die in deze publicatie verschijnen, kunt u het document *Regulatory Compliance and Safety Information* (Informatie over naleving van veiligheids- en andere voorschriften) raadplegen dat bij dit toestel is ingesloten.

Varoitus Tämä varoitusmerkki merkitsee vaaraa. Olet tilanteessa, joka voi johtaa ruumiinvammaan. Ennen kuin työskentelet minkään laitteiston parissa, ota selvää sähkökytkentöihin liittyvistä vaaroista ja tavanomaisista onnettomuuksien ehkäisykeinoista. Tässä julkaisussa esiintyvien varoitusten käännökset löydät laitteen mukana olevasta *Regulatory Compliance and Safety Information* -kirjasesta (määräysten noudattaminen ja tietoa turvallisuudesta).

Attention Ce symbole d'avertissement indique un danger. Vous vous trouvez dans une situation pouvant causer des blessures ou des dommages corporels. Avant de travailler sur un équipement, soyez conscient des dangers posés par les circuits électriques et familiarisez-vous avec les procédures couramment utilisées pour éviter les accidents. Pour prendre connaissance des traductions d'avertissements figurant dans cette publication, consultez le document *Regulatory Compliance and Safety Information* (Conformité aux règlements et consignes de sécurité) qui accompagne cet appareil.

Warnung Dieses Warnsymbol bedeutet Gefahr. Sie befinden sich in einer Situation, die zu einer Körperverletzung führen könnte. Bevor Sie mit der Arbeit an irgendeinem Gerät beginnen, seien Sie sich der mit elektrischen Stromkreisen verbundenen Gefahren und der Standardpraktiken zur Vermeidung von Unfällen bewusst. Übersetzungen der in dieser Veröffentlichung enthaltenen

Warnhinweise finden Sie im Dokument *Regulatory Compliance and Safety Information* (Informationen zu behördlichen Vorschriften und Sicherheit), das zusammen mit diesem Gerät geliefert wurde.

Avvertenza Questo simbolo di avvertenza indica un pericolo. La situazione potrebbe causare infortuni alle persone. Prima di lavorare su qualsiasi apparecchiatura, occorre conoscere i pericoli relativi ai circuiti elettrici ed essere al corrente delle pratiche standard per la prevenzione di incidenti. La traduzione delle avvertenze riportate in questa pubblicazione si trova nel documento *Regulatory Compliance and Safety Information* (Conformità alle norme e informazioni sulla sicurezza) che accompagna questo dispositivo.

Advarsel Dette varselsymbolet betyr fare. Du befinner deg i en situasjon som kan føre til personskade. Før du utfører arbeid på utstyr, må du være oppmerksom på de faremomentene som elektriske kretser innebærer, samt gjøre deg kjent med vanlig praksis når det gjelder å unngå ulykker. Hvis du vil se oversettelser av de advarslene som finnes i denne publikasjonen, kan du se i dokumentet *Regulatory Compliance and Safety Information* (Overholdelse av forskrifter og sikkerhetsinformasjon) som ble levert med denne enheten.

Aviso Este símbolo de aviso indica perigo. Encontra-se numa situação que lhe poderá causar danos físicos. Antes de começar a trabalhar com qualquer equipamento, familiarize-se com os perigos relacionados com circuitos eléctricos, e com quaisquer práticas comuns que possam prevenir possíveis acidentes. Para ver as traduções dos avisos que constam desta publicação, consulte o documento *Regulatory Compliance and Safety Information* (Informação de Segurança e Disposições Reguladoras) que acompanha este dispositivo.

¡Advertencia! Este símbolo de aviso significa peligro. Existe riesgo para su integridad física. Antes de manipular cualquier equipo, considerar los riesgos que entraña la corriente eléctrica y familiarizarse con los procedimientos estándar de prevención de accidentes. Para ver una traducción de las advertencias que aparecen en esta publicación, consultar el documento titulado *Regulatory Compliance and Safety Information* (Información sobre seguridad y conformidad con las disposiciones reglamentarias) que se acompaña con este dispositivo.

Warning! Denna varningssymbol signalerar fara. Du befinner dig i en situation som kan leda till personskada. Innan du utför arbete på någon utrustning måste du vara medveten om farorna med elkretsar och känna till vanligt förfarande för att förebygga skador. Se förklaringar av de varningar som förekommer i denna publikation i dokumentet *Regulatory Compliance and Safety Information* (Efterrättelse av föreskrifter och säkerhetsinformation), vilket medföljer denna anordning.

Electrical Equipment Guidelines

Follow these basic guidelines when working with any electrical equipment:

- Before beginning any procedures requiring access to the chassis interior, locate the emergency power-off switch for the room in which you are working.
- Disconnect all power and external cables before moving a chassis.
- Do not work alone if potentially hazardous conditions exist.
- Never assume that power has been disconnected from a circuit; always check.
- Do not perform any action that creates a potential hazard to people or makes the equipment unsafe.
- Carefully examine your work area for possible hazards such as moist floors, ungrounded power extension cables, and missing safety grounds.

Telephone Wiring Guidelines

Use the following guidelines when working with any equipment that is connected to telephone wiring or to other network cabling:

- Never install telephone wiring during a lightning storm.
- Never install telephone jacks in wet locations unless the jack is specifically designed for wet locations.
- Never touch uninsulated telephone wires or terminals unless the telephone line has been disconnected at the network interface.
- Use caution when installing or modifying telephone lines.

Preventing Electrostatic Discharge Damage

Electrostatic discharge (ESD) damages equipment and impairs electrical circuitry. ESD occurs when printed circuit boards are improperly handled and results in complete or intermittent failures

The network processing engine, I/O controller, port adapters, and wireless modem cards consist of a printed circuit board that is fixed in a metal carrier. Electromagnetic interference (EMI) shielding, connectors, and a handle are integral components of the carrier. Handle the network processing engine, I/O controller, port adapters, and wireless modem cards by their carrier edges and handles; never touch the printed circuit board when handling either component.

Figure 8 shows the location of a printed circuit board when it is installed in a network processing engine, I/O controller, or Cisco uBR7200 series modem card metal carrier. Do not touch the printed circuit board when handling either component.

Figure 8 Handling the Cisco uBR7200 Series Wireless Modem Cards—Side View

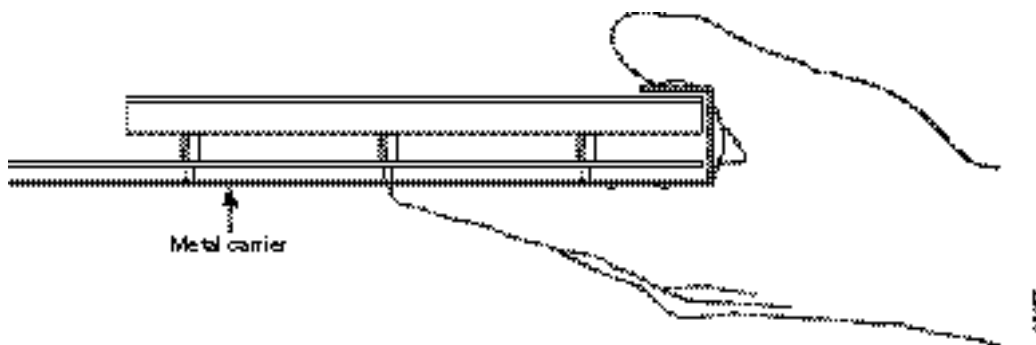

Although the metal carrier helps to protect the printed circuit boards from ESD, wear a preventive antistatic strap whenever handling the network processing engine, I/O controller, port adapters, or wireless modem cards. Ensure that the strap makes good skin contact and connect the strap's clip to an unpainted chassis surface to safely channel unwanted ESD voltages to ground.

If no wrist strap is available, ground yourself by touching the metal part of the chassis.



Caution Make sure to tighten the captive installation screws on the network processing engine, the I/O controller, and the wireless modem cards (use a number 2 Phillips screwdriver). These screws prevent accidental removal, provide proper grounding for the router, and help to ensure that the network processing engine, I/O controller, and modem cards are properly seated in the router midplane.

Following are guidelines for preventing ESD damage:

- Always use an ESD wrist strap or ankle strap when installing or replacing the network processing engine, I/O controller, port adapters, or modem cards. Ensure that the ESD strap makes contact with your skin.
- Handle the network processing engine, I/O controller, port adapters, or modem cards by their metal carrier edges and handles only; avoid touching the printed circuit board components or any connector pins.
- When removing the network processing engine, I/O controller, port adapters, or wireless modem cards, place them on an antistatic surface with the printed circuit board components facing upward, or in a static shielding bag. If you are returning an I/O controller, network processing engine, port adapter, or modem card to the factory, immediately place it in a static shielding bag.



Caution Periodically check the resistance value of the antistatic strap. The measurement should be within the range of 1 and 10 megohm (Mohm).

Compliance with U.S. Export Laws and Regulations Regarding Encryption

This product performs encryption (in the baseline privacy feature) and is regulated for export by the U.S. Government. Following is specific information regarding compliance with U.S. export laws and regulations for encryption products:

- This product is *not* authorized for use by persons located outside the United States and Canada that do not have export license authority from the U.S. Government.
- This product may *not* be exported outside the U.S. and Canada either by physical or electronic means without the *prior* written approval of the U.S. Government.
- Persons outside the U.S. and Canada may *not* reexport, resell, or transfer this product by either physical or electronic means without *prior* written approval of the U.S. Government.

Removing and Installing a Wireless Modem Card

The following sections explain how to remove and replace or install a wireless modem card in a Cisco uBR7200 series router.

Removing a Wireless Modem Card

The following procedures explain how to remove a wireless modem card from a Cisco uBR7200 series router:

- Step 1** Attach an ESD-preventive wrist strap between you and an unfinished chassis surface.
- Step 2** Unscrew the captive installation screws on the front of the wireless modem card. (See Figure 9.)

Figure 9 Captive Installation Screws

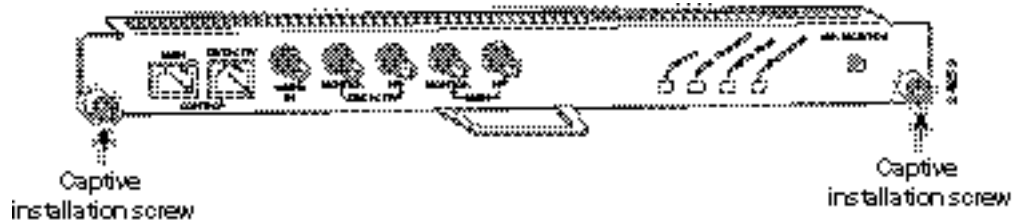

- Step 3** Grasp the handle on the wireless modem card and carefully pull the modem card from the midplane, about halfway out of its slot. If you are removing a blank modem card, pull the blank modem card all the way out of the chassis slot.
- Step 4** With the wireless modem card halfway out of the slot, disconnect all cables from the front of the modem card.
- Step 5** After disconnecting the cables, pull the modem card from its chassis slot.



Caution Always handle the wireless modem card by the carrier edges and handle; never touch the modem card's components or connector pins. (See Figure 8.)

- Step 6** Place the modem card on an antistatic surface with its components facing upward, or in a static shielding bag. If the modem card will be returned to the factory, immediately place it in a static shielding bag.

This completes the procedure for removing a wireless modem card from the Cisco uBR7200 series router.

Installing or Replacing a Wireless Modem Card

Complete the following steps to install or replace a wireless modem card in the Cisco uBR7200 series router:

- Step 1** Attach an ESD-preventive wrist strap between you and an unfinished chassis surface.
- Step 2** Use both hands to grasp the modem card by its metal carrier edges and position the modem card so that its components are downward. (See Figure 8.)
- Step 3** Align the left and right edges of the modem card metal carrier between the guides in the modem card slot. (For the Cisco uBR7246, see Figure 10. For the Cisco uBR7223, see Figure 11.)

Figure 10 **Aligning the Wireless Modem Card Metal Carrier Between the Slot Guides**
(Cisco uBR7246 Shown)

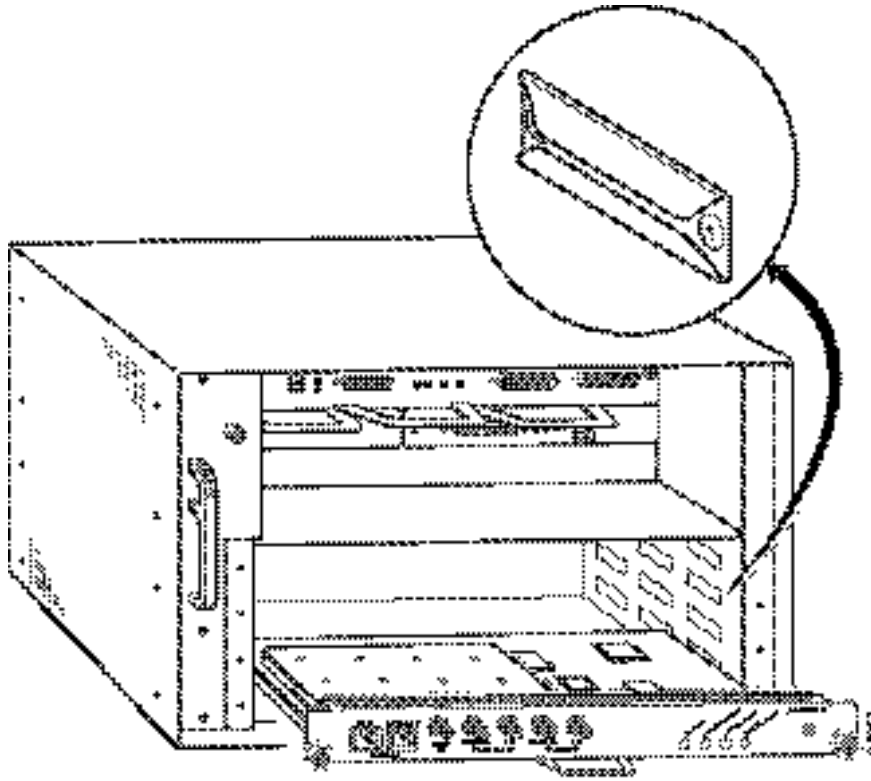
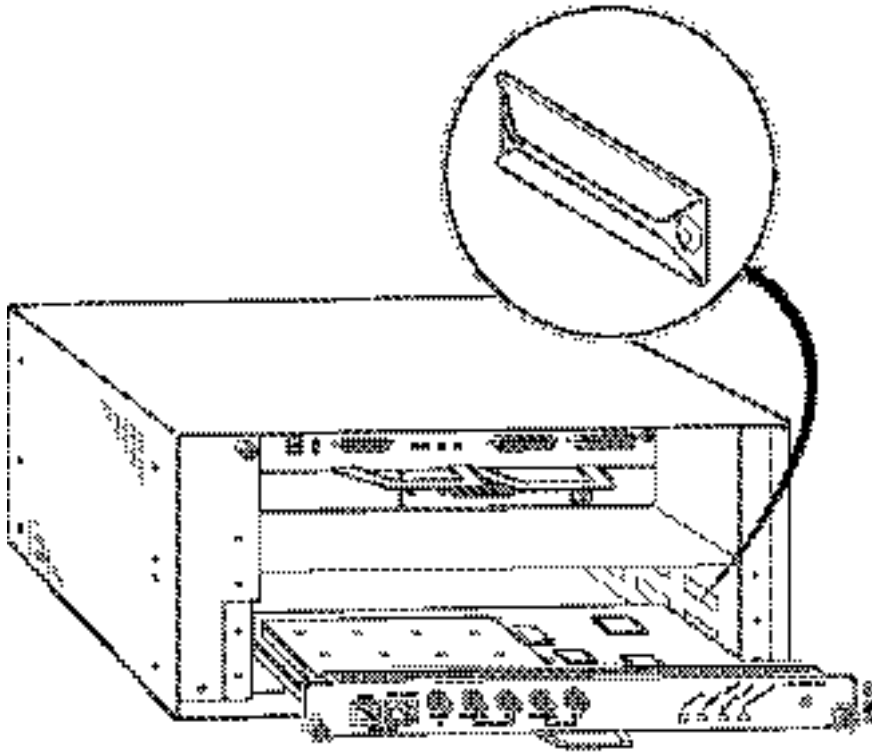

Figure 11 Aligning the Wireless Modem Card Metal Carrier Between the Slot Guides (Cisco uBR7223 Shown)



Step 4 With the metal carrier aligned in the slot guides, gently slide the modem card halfway into the modem card slot.



Caution Do not slide the modem card all the way into the slot until you have connected all required cables. Trying to do so will disrupt normal operation of the router.

Step 5 With the modem card halfway in the slot, connect all required cables to the front of the modem card. (See the section "Cabling a Wireless Modem Card" on Page 3.)

Step 6 After connecting all required cables, carefully slide the modem card all the way into the slot until you feel the card's connectors mate with the midplane.

Step 7 Tighten the captive installation screws on the modem card. (See Figure 9.)

Note If the modem card captive installation screws do not tighten all the way, the card is not completely seated in the midplane. Carefully pull the modem card halfway out of the slot, reinsert it, and tighten the captive installation screws.

This completes the procedure for installing a wireless modem card in the Cisco uBR7200 series router.

Cabling a Wireless Modem Card

Attaching the RF Control Cables

Insert the RJ45 connector on the control cable into the Main Control connector port. If you will be using the diversity option, use a second cable and attach it to the Diversity Control connector port.

Attaching the IF and Monitor Cables

Connect one end of the IF signal cable to the Main PFP port. If you will be using the diversity option, use a second cable and attach it to the Diversity PFP port.

(Optional) To use a spectrum analyzer to test or troubleshoot the signal on the modem card, attach it to the Main Monitor port or Diversity Monitor port.

Cabling the 10 MHz Clock

To connect to a 10 MHz clock, connect an SMA to BMC adapter to the 10 MHz IN connector port. Attach the clock cable's BNC connector to the adapter.

This completes the procedure for installing a wireless modem card in the Cisco uBR7200 series router.

Installing a Power Feed Panel

A power feed panel can be mounted in a 19-inch rack or mounted on a wall. The unit can be co-located with the router or placed near the outdoor unit, depending on your site requirements.

Note At least one rack unit space must exist between the uBR and the power feed panel or between multiple power feed panels.

Rack-Mounting a Power Feed Panel

A power feed panel can be rack-mounted with either the front panel or the rear panel facing forward depending on the cable handling requirements of your site, or in a center-mount telco rack. The power LEDs are visible on both the front and rear panels.

Attaching the Brackets

To install a power feed panel with the front panel facing forward, attach the brackets to both sides of the unit as shown in Figure 12.

Figure 12 Bracket Installation - Front Panel Forward

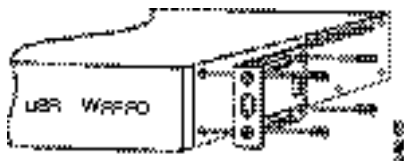

To install a power feed panel with the rear panel facing forward, attach the brackets to both sides of the unit as shown in Figure 13.

Figure 13 Bracket Installation - Rear Panel Forward



To install a power feed panel in a center-mount telco rack, attach the brackets to both sides of the unit as shown in Figure 14.

Figure 14 Telco Bracket Installation - Rear Panel Forward



Installing the Power Feed Panel in the Rack

After the brackets are secured, attach the brackets on both sides of the power feed panel to the rack as shown in Figure 15.

Figure 15 Attaching the Power Feed Panel to a Rack



Wall-Mounting the Power Feed Panel

To wall-mount the unit, use the same brackets as those used to install the power feed panel in an equipment rack.

Use the following steps to wall-mount the power feed panel:

Step 1 Attach the brackets to both sides of the power feed panel as shown in Figure 16.

Figure 16 Attaching the Wall Mount Brackets



Step 2 Attach the power feed panel to the wall as shown in Figure 17, using (customer provided) screws and anchors. To best support the power feed panel and cables, attach the brackets so that the screws align with a vertical wall stud. (See Figure 17.) This position will prevent the unit from pulling away from the wall when the cables are attached.

Note

Figure 17 Wall-Mounting the Power Feed Panel

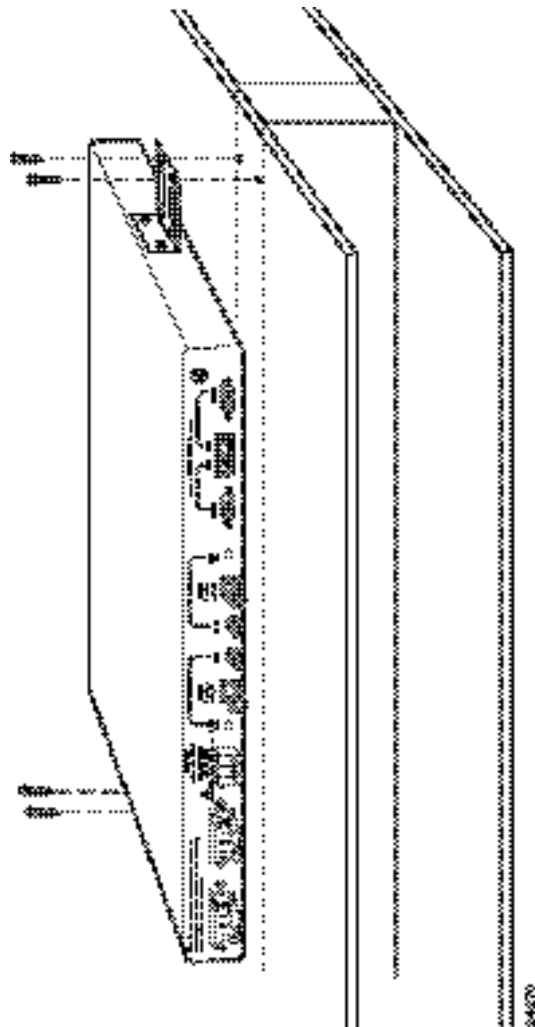

Wiring the DC Power

Follow the procedures in this section to wire the DC power.

Note The color coding of DC-input power supply leads depends on the color coding of the DC power source at your site. Typically, green or green/yellow is used for ground, black is used for +48V (return), and red or white is used for -48V. Make certain the lead color coding you choose for the DC-input power supply matches lead color coding at the DC power source.



Warning Before working on equipment that is connected to power lines, remove jewelry (including rings, necklaces, and watches). metal objects will heat up when connected to power and ground and can cause serious burns or weld the metal object to the terminals.



Warning Before performing any of the following procedures, ensure that the power is removed from the DC circuit. To ensure that all power is OFF, locate the circuit breaker on the panel board that services the DC circuit, switch the circuit breaker to the OFF position, and tape the switch handle of the circuit breaker in the OFF position.

Wiring the DC power consists of attaching the wires of the DC power source to a removable wiring block, then plugging that block into the connection on the power feed panel. Refer to Figure 19 and Figure 20 and follow these steps.

Step 1 Ensure that the leads are disconnected from the power source.



Warning The Illustration shows the DC power supply terminal block. Wire the DC power supply using the appropriate wire terminations at the wiring end, as illustrated. The proper wiring sequence is ground to ground, positive to positive (line to +), and negative to negative (neutral to -). Note that the ground wire should always be connected first and disconnected last.



Warning When stranded wiring is required, use approved wiring terminations, such as closed-loop or spade-type with upturned lugs. These terminations should be the appropriate size for the wires and should clamp both the insulation and the conductor.

Step 2 Ensure that the power switch for both the main and diversity ODU are in the OFF (0) position. (See Figure 18.)

Figure 18 ODU Power Switches

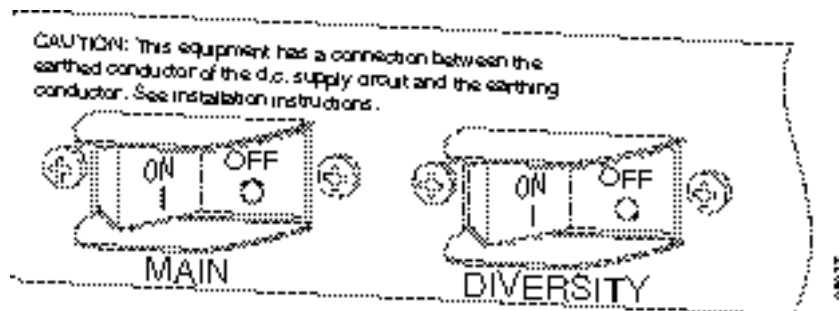

- Step 3** Using a wire stripper, strip approximately 0.55 in. (14 mm) from the +48V, -48V and ground leads.
- Step 4** Insert the stripped ends of the wire in the removable wiring block according to the scheme in Figure 19. Figure 19 illustrates the polarity of each connection. The connection on the left is for the -48VDC wire, the middle connection is for safety ground. The connection on the right is for the positive return wire.

Figure 19 Wiring Connections

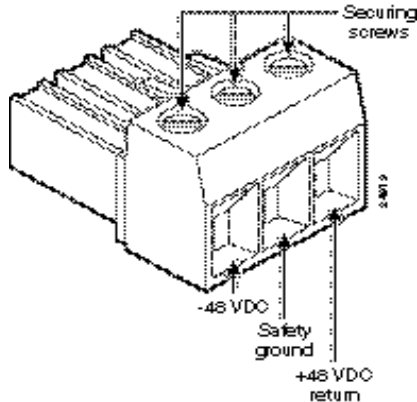

Secure the wires using the 1/8 in. blade screwdriver to tighten the screws in the top of the terminal block.

- Step 5** Connect the DC input wiring to the DC source.



Warning For personal safety, the green or green/yellow wire must connect to safety (earth) ground at both the equipment and supply side of the DC wiring.

- Step 6** Plug the terminal block into the receptacle on the power feed panel. (See Figure 20.)

Figure 20 Plugging the Terminal Block into the Receptacle

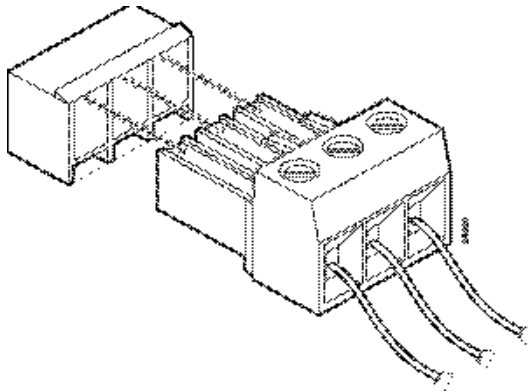

Warning After wiring the DC power supply, remove the tape from the circuit breaker switch handle and reinstate power by moving the handle of the circuit breaker to the ON position.

Cabling the Power Feed Panel

Connecting the Control Cables (from the Modem Card)

Attach the end of the control cable coming from the Control-Main port on the modem card to the Control-Main/MC port on the power feed panel. If you will be using the diversity option, also attach the second control cable coming from the Control-Diversity port on the modem card to the Control-Diversity/MC port on the power feed panel.

Connecting the Control Cables (to the ODU)

Attach a cable with a DB9 connector to the Control-Main/ODU port on the power feed panel. If you will be using the diversity feature, attach a second cable to the Control-Diversity/ODU port.

Connecting the IF Cables (from the Modem Card)

Connect the cables coming from the Main/PFP port of the modem card to the Main/MC port on the power feed panel. If you will be using the diversity feature, also connect the cable coming from the Diversity/PFP port of the modem card to the Diversity/MC port on the power feed panel.

Connecting the IF Cables (to the ODU)

Attach one end of the IF cable to the Main-ODU/Output connector. If you will be using the diversity feature, attach a second cable to the Diversity-ODU/Output connector.

This completes the procedure for installing and cabling a power feed panel.

Installing an Outdoor Unit

Installing an outdoor unit (ODU) requires the installation of the duplexor assembly prior to mounting the ODU either on an antenna pole or on a wall.

Installing the Duplexor in the Outdoor Unit

The duplexor acts as a filter for Tx/Rx isolation. The duplexor assembly is shipped as a separate unit based on the RF channel plan you have selected for your installation.

Figure 21 Duplexor Assembly

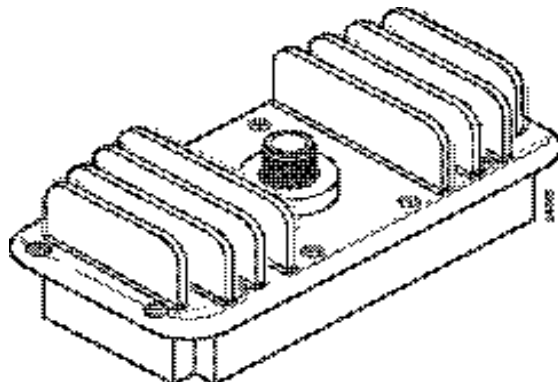

Installing an Outdoor Unit

Determining the Orientation of the Duplexor

The orientation of the duplexor when installed in the ODU, will determine its function.

Figure 22 Duplexor Orientation

Installing the Duplexor in the ODU

Figure 23 Installing the Duplexor

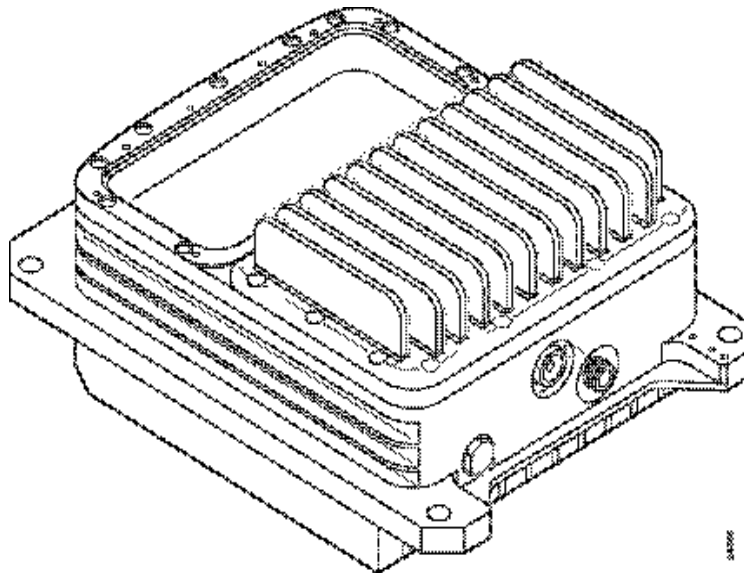

Mounting the Outdoor Unit

The ODU can be mounted either on the antenna pole or on a wall depending on site requirements. A mounting kit is included for this purpose.

Mounting the Outdoor Unit on an Antenna Pole

Use the following steps to mount the outdoor unit on an antenna pole:

[CAUTIONS]

Step 1

Figure 24 **Attaching the Mounting Bracket to the Antenna Pole**

Step 2

Step 3

Figure 25 **Attaching the ODU to the Mounting Bracket**

Step 4

Step 5

Mounting the Outdoor Unit on a Wall

Use the following steps to mount the outdoor unit on a wall:

[CAUTIONS]

Step 1

Figure 26 **Attaching the Mounting Bracket to the Wall**

Step 2

Step 3

Figure 27 Attaching the ODU to the Mounting Bracket

Step 4

Step 5

Cabling the Outdoor Unit

Cables leading to the ODU may require through-bulkhead connectors, lightning protection, or other accessories. For more detailed information concerning these items, refer to the *Cisco Wireless Broadband Router Site Planning Guide*.

Connecting the Control Cable

Connect the control cable from the power feed panel port marked Main/ODU to the Control connector on the Main ODU. (See Figure 7.)

If the diversity feature is being used, connect the control cable from the power feed panel port marked Diversity/ODU to the Control connector on the Diversity ODU.

Connecting the IF Cable

Note Ensure that the power switch (on the power feed panel) for both the Main and Diversity ODU are in the OFF (0) position. (See Figure 18.)

Connect the IF cable from the power feed panel port marked Main-ODU/Output to the IF Input connector on the Main ODU. (See Figure 7.)

If the diversity feature is being used, connect the IF cable from the power feed panel port marked Diversity-ODU/Output to the IF Input connector on the Diversity ODU.

Connecting the Antenna Cable

Connect the RF cable leading to the Main antenna to the N connector on the duplexor on the Main ODU. (See Figure 7.)

If the diversity feature is being used, connect the RF cable leading to the Diversity antenna to the N connector on the duplexor on the Diversity ODU.

This completes the procedure for installing and cabling an outdoor unit.

Configuring a Wireless Modem Card

After you have installed or replaced a wireless modem card, you must use the Cisco IOS software command-line interface (CLI) to configure the modem card for correct operations of the card and wireless subsystems. The commands for login and completing the configuration are described in this section. Commands are also provided to enable you to verify the individual tasks in the configuration process.

Note You must perform a basic configuration of the Cisco uBR7200 series router before configuring the wireless modem cards. refer to the *Cisco uBR7200 Series Universal Broadband Router Installation and Configuration Guide* publication that shipped with your Cisco uBR7246 or Cisco uBR7223 for more information.

Syntax Conventions

The following conventions are used in the:

Convention	Meaning
command-name	The actual CLI command
<replaceable parameters>	A parameter that the user needs to substitute to identify the object of interest.
[optional parameter]	A parameter that need not be specified. If specified it will qualify the command for the specified subset.
<i>keyword</i>	A keyword that has significance in the context it is being used.
{choice1 choice2}	Represents the set of choices, one of which must be specified
(detail1, detail2)	Details displayed by the CLI in response to a show command

Note All examples in the following sections use the hostname of WMCS01.

login

Use the steps in Table 6 to login and start the configuration process.

Note Some commands require privileged configuration access privileges. These commands are marked “Privileged configuration access is required”.

Table 6 Login Steps

Step	Command	Purpose
1	WMCS01(boot)> enable Password: <password> WMCS01(boot)#	Enter Exec mode. Enter the password. You are in Exec mode when the prompt changes to WMCS01(boot)#.
2	WMCS01(boot)# configure terminal password: <password> WMCS01(boot)(config)#	Enter Privileged Configuration mode. Enter the Privileged Configuration password. You are in this mode when the prompt changes to WMCS01(boot)(config)#.
3	WMCS01(boot)(config)# interface radio 3/0 WMCS01(boot)(config-if)#	Enter Interface Configuration mode for the specified modem card. You are in this mode when the prompt changes to WMC01(boot)(config-if)#

show controllers

Use this command to display all or a subset of attributes of a particular modem card. If none of the options are specified, all the hardware subsystem(s) information will be displayed. Commonly displayed parameters are shown in the "Display Elements" section. Actual output parameters depend on the hardware and implementation. Privileged configuration access is required.

Unless an error occurs, no notifications are displayed on the console.

show controllers radio <slot number>/<port number> [{if | rf | fir | codec | dsp | arq | pci | phy | driver}]

Syntax Description

- slot number Positive integer representing the Cisco uBR7200 series slot number.
- port number Positive integer representing the port number on that slot.

Display Elements

- if* (version, freq, register1)
 - version Name, version of the module.
 - freq Intermediate frequency being used.
 - register1 IF Register 1.
- rf* (version, freq, power)
 - version Name, version of the module.
 - freq Current operating frequency.
 - power Minimum, maximum power capacity.
- fir* (version, firThresh,)
 - version Name, version of the module.
 - firThresh Queue threshold.
- codec* (version, rsDecodeErrThresh, rdDecodeErrBytes)
 - version Name, version of the module.
 - rsDecodeErrThresh Decode error threshold.
 - rdDecodeErrBytes TBD.
- dsp* version Name, version of the module.
- arq* (version, arqThresh)
 - version Name, version of the module.
 - arqThresh ARQ threshold
- pci* version Name, version of the module.

Example

The following example shows the output received when no options are specified for the modem card in slot number 3, port number 0.

```
WMCS01(boot)# show controllers radio 3/0

Interface Radio6/0
Hardware is CW Radio Point-to-Point Line Card
```

ALPHA DRAFT - CISCO CONFIDENTIAL

Configuring a Wireless Modem Card

```
throttled 0 enabled 0 disabled 0
Rx: spurious 0 framing_err 0 no_buffer 0, pause_no_err_ints 0
    no_enqueue 0 no_stp 0 no_enp 0
Tx: full 0 drop 0
rx ring entries 32 tx ring entries 128
rx ring 0x4B05A0C0 shadow 0x61399C60 head 2
Normal Latency Tx ring 0x4B05A680 shadow 0x6139A1C0 head 0 tail 0 count 0
Low Latency Tx ring 0x4B05A220 shadow 0x61399D50 head 3 tail 3 count 0
```

PCI Configuration Registers

```
Device/Vendor IDs - 0x00141137
Command/Status   - 0x02000086
Latency Timer     - 0x0000FF00
Base Address 0    - 0x000001FF
```

PCI Interface FPGA

```
dmac_control      - 0x00440002
dmac_status       - 0x00004000
dmac_int_status   - 0x99800001
dmac_int_enable   - 0x66710FF8
dmac_tx0_ring_base - 0x4B05A220
dmac_tx1_ring_base - 0x4B05A680
dmac_rx_ring_base - 0x4B05A0C0
dmac_configuration - 0x66040303
local_bus_error_status - 0x00000000
local_bus_error_address - 0x010C0000
local_bus_reset   - 0x00000000
fpga_configuration_control - 0x00000000
fpga_configuration_status - 0x000000FF
```

PHY Interface FPGA

```
tx_cbc_iv[0]      - 0x00000000 0x00000000 0x00000000 0x00000000
tx_cbc_iv[1]      - 0x00000000 0x00000000 0x00000000 0x00000000
rx_cbc_iv[0]      - 0x00000000 0x00000000 0x00000000 0x00000000
rx_cbc_iv[1]      - 0x00000000 0x00000000 0x00000000 0x00000000
rx_key_sequence[0] - 0x00000000 rx_key_sequence[1] - 0x00000000
framer_control    - 0x00000003 overrun_count - 0x00000000
loopback_control  - 0x00000000
timer_control     - 0x00000000 timer_down_count - 0x00000001
```

cwrP2pArqSubsystem:: "arq" (1)

for card = "p2p" (2)

```
burst rate = 10869 bursts/sec
codeword rate = 24358 codewords/sec
ARQ overhead = 7 codewords
processing latency = 1400 usec (34 codewords)
overall latency = 20000 usec (453 codewords)
ARQ burst size = 16 codewords
ARQs per CW error = 4
ARQ spacing = 64 codewords
RRs per SCW error = 6
RR spacing = 38 codewords
```

Registers in group "arq":

```
mi = 0x00005EB5 rrc = 0x000001FC arq = 0x000001FB
atxi = 0x000003D0 arxi = 0x000003A0 arqo = 0x00000007
burst = 0x00000010 cwthsh = 0x00002F5A prbs = 0x00000000
dlat = 0x000000FF intstat = 0x000007D4 inten = 0x00000000
host = 0x00000001 arqm = 0x00000035 vlat = 0x0000007F
cwlen = 0x00000080 hdlc = 0x00000000 rxlen = 0x000000F3
cwespc = 0x000003FF besize = 0x00000007 bespc = 0x0000FFFF
cwbe = 0x00000000 test = 0x00000000 cwerr = 0x00000000
ccwerr = 0x00000000 derr = 0x00000047 sberr = 0x00000000
arqreq = 0x00000000 plarq = 0x00000000 plrrr = 0x00000000
plr = 0x00000000 bec1 = 0x00000000 bec2 = 0x00000000
bec3 = 0x00000000 bec4 = 0x00000000 bec5 = 0x00000000
bec6 = 0x00000000 bec7 = 0x00000000 bec8 = 0x00000000
```

```

        bec9 = 0x00000000      rxcsnap = 0x00005EB6      syncstat = 0x00000009
cwrP2pcodecSubsystem:: "coded" (2)
  for card = "p2p" (2)
    convolutional rate = 7/8
      Ndata = 864
    local loopback = not looped
Registers in group "ctx":
  t = 0x00000000          c = 0x00000026          isr = 0x00000002
  ier = 0x00000000      led = 0x000003FF
Registers in group "ctx":
  tsr = 0x00000008      cr = 0x00000026          sir = 0x0000FFFF
  scr = 0x000000FF      isr = 0x00000004          ier = 0x00000000
  ndt = 0x00000360      smcr = 0x00000072          becr = 0x0000FFFF
  rscr = 0x00000001      rsdr = 0x00000000          lcr = 0x00000001
  lpr = 0x00000000      errstat = 0x0000009C      errsize = 0x00000020
  vrssize = 0x00000058  vsyncp = 0x00000047      vrsth = 0x00000008
  verth = 0x0000007F    vcon = 0x00000097      msgbytes2 = 0x000000FC
  rseed0 = 0x000000A9   rseed1 = 0x00000000      iocntrl = 0x000000D0
  njl = 0c000000E8      njm = 0x00000005        blkklen2 = 0x000000FC
  jdepth = 0x00000056   rsdec = 0x00000000
cwrP2pDspSubsystem:: "dsp" (3)
  for card = "p2p" (2)
    num RX antennae = 2
      bandwidth = 12000000 Hz
      throughput = high
      Ndata = 864
    Codec vframe size = 16
    FIR vframe size = 48
    IF gain update delay = 97600 ns
cwrP2pDspDerivedParams::
  num RX DSPs used = 6
    x2method = no
Ntable (32 entries) =
  378  729  351  486  675  162  189  594
  243  108  135  270  567  756  702  432
  648  621  27  459  216  513  81  0
  297  540  405  783  324  810  54  837
Ptable (27 entries) =
  0  768  544  160  704  320  192  96
  608  64  384  800  288  416  256  672
  640  32  128  352  576  512  448  224
  736  480  832
Mtable (32 entries) =
  0x0208 0x025C 0x001C 0x0006 0x001E 0x000E 0x002E 0x0000
  0x0000 0x0000 0x0000 0x0000 0x0000 0x0000 0x0000 0x0000
  0x02D6 0x00DC 0x00DE 0x0000 0x0000 0x0000 0x0000 0x0000
  0x0000 0x0000 0x0000 0x0000 0x0000 0x0000 0x0000 0x0000
Registers in group "txseq":
  c = 0x00000F15          ndata = 0x0000035F
Registers in group "rxseq":
  csr = 0x0000BC81      fircmd = 0x0000FFFF      ndata = 0x0000135F
  crt = 0x0000069F      ups = 0x0000002E        ifc = 0x00000987
cwrP2pFirSubsystem:: "fir" (4)
  for card = "p2p" (2)
    num Rx antennae = 2
      bandwidth = 12000000 Hz
      N+L+nu = 11-4
    outer local loopback = looped
cwrP2pFirDerivedParams::
  flbusDest=0x00 lfAddr=0x0400 pktData= 0x000A
  flbusDest=0x20 lfAddr=0x0400 pktData= 0x0009
  flbusDest=0x00 lfAddr=0x0800 pktData= 0x0000 0x0002 0x0000 0x0000
  flbusDest=0x20 lfAddr=0x0800 pktData= 0x0000 0x0004 0x0000 0x0000
  flbusDest=0x00 lfAddr=0x0C00 pktData= 0x0001 0x00C0 0x00FF 0x003F
  flbusDest=0x20 lfAddr=0x0C00 pktData= 0x0004 0x00E0 0x00FC 0x001F

```

ALPHA DRAFT - CISCO CONFIDENTIAL

Configuring a Wireless Modem Card

```
filbusDes=0x00 lfAddr=0x0205 pktData= 0x0000
filbusDes=0x20 lfAddr=0x0205 pktData= 0x0000
filbusDes=0x00 lfAddr=0x0201 pktData= 0x0046
filbusDes=0x20 lfAddr=0x0201 pktData= 0x0046
filbusDes=0x00 lfAddr=0x0200 pktData= 0x0002
filbusDes=0x20 lfAddr=0x0200 pktData= 0x0002
filbusDes=0x00 lfAddr=0x0204 pktData= 0x0002
filbusDes=0x20 lfAddr=0x0204 pktData= 0x0002
Filter Coefficients (looped) =
0x01D7 0x07B4 0x0241 0xFC87 0x02B7 0xFE43 0x00F2 0xFF9F
0xFFA9 0xFB20 0xF8E4 0x02E9 0xFFCE 0xFEFC 0x0169 0xFE95
0xFF1D 0xF97B 0xFAEF 0x03EA 0xFE10 0x0091 0x0039 0xFF5F
0x0016 0x0337 0x07FF 0xFF57 0xFE20 0x0251 0xFDF7 0x0192
0xFFFF 0x003F 0xFFA1 0x0073 0xFF68 0x0119 0x0068 0xFFFB
0x0143 0xFE66 0x00CD 0xFF65 0x0079 0xFFAC 0xFF06 0xFFF5
0x00CD 0xFF2B 0x00C6 0xFF4B 0x00B3 0xFF31 0xFF4E 0x0002
0xFEE2 0x00B9 0xFF98 0x002F 0xFFFB 0xFFCD 0x0124 0x002E
0x0010 0x0251 0x05C4 0xFF86 0FEA6 0x01AB 0xFE88 0x0122
0xFFC1 0xFC7C 0FAE0 0x0219 0xFFDC 0xFF45 0x0104 0FEFA
0xFF5c 0xFB4D 0xFC59 0x02D2 0xFE9B 0x0069 0x0029 0xFF8C
0x0154 0x058E 0x01A0 0xFD7F 0x01F5 0FEBF 0x00AE 0xFFBA
0xFF32 0x0085 0xFFB5 0x0022 0xFFFC 0xFFDB 0x00D3 0x0021
0x00E9 0xFF40 0x0094 0xFF90 0x0058 0xFFC3 0xFF4C 0xFFF8
0x0094 0xFF66 0x008F 0xFF7E 0x0081 0xFF6B 0xFF80 0x0001
0xFFFF 0x002D 0xFFBC 0x0053 0xFF92 0x00CB 0x004B 0xFFFF
Registers in group "ftim":
    c = 0x00000019          t = 0x00000000          nlv = 0x0000044F
    slip = 0x00000000      instat = 0x00000000      inten = 0x00000003
    syncdly = 0x00000001
Registers in group "fdat":
    c = 0x00000019          t = 0x00000A00          nlv = 0x0000044F
    flbus = 0x00000080      instat = 0x00000001      inten = 0x00000001
    flbus_dat = 0x00000000  flbus_star = 0x00000000
IF
RF
```

show interfaces

Use this command to display the protocol-specific details supported by the identified interface. The **show interfaces** command is also the starting point to display interface-specific configurations such as thresholds and histograms.

Unless an error occurs, no notifications are displayed on the console.

show interfaces radio <slot number>/<port number>

Syntax Description

- slot number Positive integer representing the Cisco uBR7200 series slot number.
- port number Positive integer representing the port number on that slot

Example

The following example shows the display received for the modem card located in slot 3, port 0.

```
WMCS01(boot)# show interfaces radio 3/0

Radio 3/0 is up, line protocol is up
Hardware is CWR_P2P_1.
Internet address is 192.168.168.233/24
MTU 1500 bytes, BW 10000 Kbit
codeword error rate 20 codewords/50000 codewords.
byte error rate 20 errors/1000000 bytes.
```

show running-configuration show startup-configuration

Use the command **show running-configuration** to display the configuration currently in effect on the Cisco uBR7200 series router. Use the **show startup-configuration** command to display the system startup configuration.

Unless an error occurs, no notifications are displayed on the console.

show <{*running-configuration* | *startup-configuration*}> <interfaceSpec>

ALPHA DRAFT - CISCO CONFIDENTIAL

Configuring a Wireless Modem Card

Syntax Description

`interfaceSpec` interface <subsystem> <slotnum>/<portnum>

`subsystem` <{ip | arp | | radio}>

`slotnum` Positive integer representing the Cisco uBR7200 series slot number.

`portnum` Positive integer representing the port number on that slot.

Example

the following example displays the configuration currently in effect on the Cisco uBR7200 series router.

```
WMCS01(boot)# show running-configuration

Building configuration...

Current configuration:
!
version 11.1
service udp-small-servers
service tcp-small-servers
!
hostname WMCS01
!
enable password clarity
!
username clarity
!
interface FastEthernet0/0
 no ip address
 no ip route-cache
 shutdown
 media-type MII
!
ip name-server 192.168.168.1
ip name-server 192.168.168.181
ip name-server 192.168.168.178
!
line con 0
 exec-timeout 0 0
line aux 0
line vty 0 4
 password clarity
 login local
!
interface clarityRadio3/0
 radio master
 radio operating-band UNII
 radio channel-setup bandwidth 6 throughput medium
 radio transmit-power 22
 radio cable-loss 7
 radio event-threshold .....
 radio dsp-statistics .....
 radio codec-statistics .....
!
end
```

write

Use this command to write the configuration currently being executed by the Cisco uBR7200 series router to a specified device.

Unless an error occurs, no notifications are displayed on the console.

write <{**memory** | **network** | **terminal** | **erase**}>

ALPHA DRAFT - CISCO CONFIDENTIAL

Configuring a Wireless Modem Card

Syntax Description

memory	Configuration will be written to NV memory.
network	<remote-host><configFileName>
remote-host	IP address of the host.
configFileName	The name of a file in which to save the configuration
terminal	Configuration will be written to the terminal
erase	Contents of NV memory will be erased.

Example

The following example shows the command to write the current configuration information to the console.

```
WMCS01(boot)# write terminal

Building configuration...

Current configuration:
!
version 11.1
service udp-small-servers
service tcp-small-servers
!
hostname WMCS01
!
enable password clarity
!
username clarity
!
interface FastEthernet0/0
no ip address
no ip route-cache
shutdown
media-type MII
!
ip name-server 192.168.168.1
ip name-server 192.168.168.181
ip name-server 192.168.168.178
!
line con 0
exec-timeout 0 0
line aux 0
line vty 0 4
password clarity
login local
!
interface clarityRadio3/0
radio master
radio operating-band UNII
radio channel-setup bandwidth 6 throughput medium
radio transmit-power 22
radio cable-loss 7
radio event-threshold .....
radio dsp-statistics .....
radio codec-statistics .....
!
```

```
end
```

copy

Use this command to write the contents of the source to the specified destination device or file.

Unless an error occurs, no notifications are displayed on the console.

copy <src> <dstn>

Syntax Description

src	Source name.
dstn	Destination name.

Example

(explanation of example here)

```
WMCS01(boot)# copy TBD
```

shut (shutdown and restart)

Use this command to shut down the radio link.

Use the **no** version of the command to initiate the necessary actions to re-instate the radio link.

Unless an error occurs, no notifications are displayed on the console.

shut
no shut

Example

The following command will shut down the radio link.

```
WMCS01(boot)(config-if)# radio shut
```

radio master

Use this command to configure the wireless modem card to operate as the master radio. The master radio acts as the frequency source; the radio designated as the slave will track to the changes in the master's frequency. This command can be issued only when the radio link is down (**shut**), and will take effect when the link is again active (**no shut**). Privileged configuration access is required.

Note The center frequency of both master and slave must be configured by using the appropriate **operating band** and **channel parameters** commands.

Use the **no** version of the command to switch the modem card to slave mode.

Note Use the **show running-configuration <interfaceSpec>** command to display the current setting.

Unless an error occurs, no notifications are displayed on the console.

radio master
no radio master

Example

The following example configures the wireless modem card to operate as the master radio.

```
WMCS01(boot)(config-if)# radio master
```

receive-antennas

Use this command to configure the wireless modem card to use a specified number of receive antennas. This command can be issued only when the radio link is down (**shut**), and will take effect when the link is again active (**no shut**). Privileged configuration access is required.

Note Before this command can take effect, the receive antennas must be available.

Use the **no** version of the command to set the number of receive antennas to 1.

Note Use the **show running-configuration<interfaceSpec>** command to display the current setting.

Unless an error occurs, no notifications are displayed on the console.

receive-antennas <{1 | 2}>
no receive-antennas

Example

The following example configures the wireless modem card to use two receive antennas.

```
WMCS01(boot)(config-if)# receive-antennas 2
```

operating-band

Use this command to specify the radio operating band and transmit/receive frequencies within that band. Operating band may be set to UNII (frequency range 5725 to 5825 MHz), or MMDS (frequency range 2500 to 2690 MHz.). Transmit frequency on the wireless modem card operating as the master radio must be identical to the receive frequency on the modem card acting as the slave radio. This command can be issued only when the radio link is down (**shut**), and will take effect when the link is again active (**no shut**). Privileged configuration access is required.

Note To operate in the MMDS band, it is necessary to own that part of the spectrum.

Use the **no** form of the command to reset the operating band to the default values.

Note Use the **show running-configuration<interfaceSpec>** command to display the current setting.

Unless an error occurs, no notifications are displayed on the console.

radio operating-band <{UNII | MMDS}> Tx <TransmitFrequency> Rx <ReceiveFrequency>
no radio operating-band

Syntax Description

TransmitFrequency Positive number in the range 215000 to 269000 (MMDS) or 572500 to 582500 (UNII)

ReceiveFrequency Positive number in the range 215000 to 269000 (MMDS) or 572500 to 582500 (UNII)

Selecting the Transmit and Receive Frequencies

Use the **channel-setup** parameters to select the required bandwidth and data throughput prior to specifying the **operating-band**.

Transmit and receive frequencies must fall within the specified bank (UNII or MMDS), must be consistent with the bandwidth the radio has been configured to operate in using the **channel-setup** command. The following tables provide center frequencies for the different bands. Transmit and receive frequencies must both be selected from one of the tables.

The transmit frequency on the master radio must be identical to the receive frequency on the slave radio.

Note Although all the possible frequencies are listed in the tables, the actual list of frequencies available for use will be determined by the installed RF hardware. Use the **show controller interface radio** command to determine these capabilities and select appropriate transmit and receive frequencies.

The MMDS band is divided into two frequency bands:

- The lower frequency band is between 2150 and 2162 MHz (Table 7).
- The upper frequency band is between 2500 and 2690 MHz (Table 8).

Table 7 **Lower MMDS Band Center Frequencies**

1.5Msps	3.0Msps	6.0Msps	12Msps
2150.75	2151.5	2153	2156
2152.25	2154.5	2159	–
2153.75	2157.5	–	–
2155.25	2160.5	–	–
2156.75	–	–	–
2158.25	–	–	–

ALPHA DRAFT - CISCO CONFIDENTIAL

Configuring a Wireless Modem Card

Table 7 Lower MMDS Band Center Frequencies (continued)

1.5Msps	3.0Msps	6.0Msps	12Msps
2159.75	–	–	–
2161.25	–	–	–

Table 8 Upper MMDS Band Center Frequencies

1.5Msps	3.0Msps	6.0Msps	12Msps
2500.75	2501.5	2503	2506
2502.25	2504.5	2509	2518
2503.75	2507.5	2515	2530
2505.25	2510.5	2521	2542
2506.75	2513.5	2527	2554
2508.25	2516.5	2533	2566
2509.75	2519.5	2539	2578
2511.25	2522.5	2545	2590
2512.75	2525.5	2551	2602
2514.25	2528.5	2557	2614
2515.75	2531.5	2563	2626
2517.25	2534.5	2569	2638
2518.75	2537.5	2575	2650
2520.25	2540.5	2581	2662
2521.75	2543.5	2587	2674
2523.25	2546.5	2593	–
224.75	2549.5	2599	–
2526.25	2552.5	2605	–
2527.75	2555.5	2611	–
2529.25	2558.5	2617	–
2530.75	2561.5	2623	–
2532.25	2564.5	2629	–
2533.75	2567.5	2635	–
2535.25	2570.5	2641	–
2536.75	253.5	2647	–
2538.25	2576.5	2653	–
2539.75	2579.5	2659	–
2541.25	252.5	2665	–
2542.75	2585.5	2671	–
2544.25	258.5	2677	–
2545.7	2591.5	2683	–
2547.25	2594.5	–	–

Table 8 Upper MMDS Band Center Frequencies (continued)

1.5Msps	3.0Msps	6.0Msps	12Msps
2548.75	2597.5	–	–
2550.25	2600.5	–	–
2551.75	2603.5	–	–
2553.25	2606.5	–	–
2554.75	2609.5	–	–
2556.25	2612.5	–	–
2557.75	2615.5	–	–
2559.25	2618.5	–	–
2560.75	2621.5	–	–
2562.25	2624.5	–	–
2563.75	2627.5	–	–
2565.25	2630.5	–	–
2566.75	2633.5	–	–
2568.25	2536.5	–	–
2569.75	2639.5	–	–
2571.25	2642.5	–	–
2572.75	2645.5	–	–
2574.25	2648.5	–	–
2575.75	2651.5	–	–
2577.25	2654.5	–	–
2578.75	2657.5	–	–
2580.25	2660.5	–	–
2581.75	2663.5	–	–
2583.25	2666.5	–	–
2584.75	2669.5	–	–
2586.25	2672.5	–	–
2587.75	2675.5	–	–
2589.25	2678.5	–	–
2590.75	2681.5	–	–
2592.25	2684.5	–	–
2593.75	2687.5	–	–
2595.25	–	–	–
2596.75	–	–	–
2598.25	–	–	–
2599.75	–	–	–
2601.25	–	–	–
2602.75	–	–	–
2604.25	–	–	–

Table 8 Upper MMDS Band Center Frequencies (continued)

1.5Msps	3.0Msps	6.0Msps	12Msps
2605.75	–	–	–
2607.25	–	–	–
2608.75	–	–	–
2610.25	–	–	–
2611.75	–	–	–
2613.25	–	–	–
2614.75	–	–	–
2616.25	–	–	–
2617.75	–	–	–
2619.25	–	–	–
2620.75	–	–	–
2622.25	–	–	–
2623.75	–	–	–
2625.25	–	–	–
2626.75	–	–	–
2628.25	–	–	–
2629.75	–	–	–
2631.25	–	–	–
2632.75	–	–	–
2634.25	–	–	–
2635.75	–	–	–
2637.25	–	–	–
2638.75	–	–	–
2640.25	–	–	–
2641.75	–	–	–
2643.25	–	–	–
2644.75	–	–	–
2646.25	–	–	–
2647.75	–	–	–
2649.25	–	–	–
2650.75	–	–	–
2652.25	–	–	–
2653.75	–	–	–
2655.25	–	–	–
2656.75	–	–	–
2658.25	–	–	–
2659.75	–	–	–
2661.25	–	–	–

Table 8 Upper MMDS Band Center Frequencies (continued)

1.5Msps	3.0Msps	6.0Msps	12Msps
2662.75	–	–	–
2664.25	–	–	–
2665.75	–	–	–
2667.25	–	–	–
2668.75	–	–	–
2670.25	–	–	–
2671.75	–	–	–
2673.25	–	–	–
2674.75	–	–	–
2676.25	–	–	–
2677.75	–	–	–
2679.25	–	–	–
2680.75	–	–	–
2682.25	–	–	–
2683.75	–	–	–
2685.25	–	–	–
2686.75	–	–	–
2688.25	–	–	–

Table 9 lists the possible center frequencies for the UNII band.

Table 9 UNII Band Center Frequencies

1.5Msps	3.0Msps	6.0Msps	12Msps
5726.25	5727	5730	5733
5727.75	5730	5736	5745
5729.25	5733	5742	5757
5730.75	5736	5748	5769
5732.25	5739	5754	5781
5733.75	5742	5760	5793
5735.25	5745	5766	5805
5736.75	5748	5772	5817
5738.25	5751	5778	–
5739.75	5754	5784	–
5741.25	5757	5790	–
5742.75	5760	5796	–
5744.25	5763	5802	–
5745.75	5766	5808	–
5747.25	5769	5814	–

ALPHA DRAFT - CISCO CONFIDENTIAL

Configuring a Wireless Modem Card

Table 9 UNII Band Center Frequencies (continued)

1.5Msps	3.0Msps	6.0Msps	12Msps
5748.75	5772	5820	–
5750.25	5775	–	–
5751.75	5778	–	–
5753.25	5781	–	–
5754.75	5784	–	–
5756.25	5787	–	–
5757.75	5790	–	–
5759.25	5793	–	–
5760.75	5796	–	–
5762.25	5799	–	–
5763.75	5802	–	–
5765.25	5805	–	–
5766.75	5808	–	–
5768.25	5811	–	–
5769.75	5814	–	–
5771.25	5817	–	–
5772.75	5820	–	–
5774.25	5823	–	–
5775.75	–	–	–
5777.25	–	–	–
5778.75	–	–	–
5780.25	–	–	–
5781.75	–	–	–
5783.25	–	–	–
5784.75	–	–	–
5786.25	–	–	–
5787.75	–	–	–
5789.25	–	–	–
5790.75	–	–	–
5792.25	–	–	–
5793.75	–	–	–
5795.25	–	–	–
5796.75	–	–	–
5798.25	–	–	–
5799.75	–	–	–
5801.25	–	–	–
5802.75	–	–	–
5804.25	–	–	–

Table 9 UNII Band Center Frequencies (continued)

1.5Msps	3.0Msps	6.0Msps	12Msps
5805.75	–	–	–
5807.25	–	–	–
5808.75	–	–	–
5810.25	–	–	–
5811.75	–	–	–
5813.25	–	–	–
5814.75	–	–	–
5816.25	–	–	–
5817.75	–	–	–
5819.25	–	–	–
5820.75	–	–	–
5822.25	–	–	–
5823.75	–	–	–

Example

The following example sets center frequencies in the upper MMDS band.

```
WMCS01(boot)(config-if)# radio operating-band MMDS 253300 259900
```

channel-setup

Use this command to adjust bandwidth and throughput to increase the reliability of the link. For a selected bandwidth, data throughput can be reduced to increase the reliability. This command can be issued only when the radio link is down (**shut**), and will take effect when the link is again active (**no shut**). Privileged configuration access is required.

Use the **no** version of the command to reset the parameters to the defaults.

Note Use the **show running-configuration<interfaceSpec>** command to display the current setting.

Unless an error occurs, no notifications are displayed on the console.

radio channel-setup bandwidth <bw> throughput <dataThroughput>

ALPHA DRAFT - CISCO CONFIDENTIAL

Configuring a Wireless Modem Card

Syntax Description

bw {1.5 | 3 | 6 | 12}

Note The 1.5MHz and 3MHz bandwidths are for future use.

dataThroughput {high | medium | low}

high (default) At 12 MHz, maximum 44.4 Mbps.

At 6 MHz, maximum 22.2 Mbps.

medium At 12 MHz, maximum 39.1 Mbps.

At 6 Mhz, maximum 19.6 Mbps.

low At 12 MHz, maximum 22.4 Mbps.

At 6 Mhz, maximum 11.2 Mbps.

Example

The following example configures a 6MHz bandwidth and high throughput.

```
WMCS01(boot)(config-if)# radio channel-setup bw 6 throughput high
```

self-test

Use this command to configure the card to download and execute self-tests. Use the **[enable]** option to execute self-tests each time the card is initiated (**no shut**). Use the command without the **[enable]** option to perform a self-test only on the first no shut after initiation. Privileged configuration access is required.

Use the **no** version of the command to configure a restart of the link without executing self-tests.

Note Use the **show running-configuration<interfaceSpec>** command to display the current setting.

Unless an error occurs, no notifications are displayed on the console.

radio self-test [enable]

no radio self-test

Example

The following example shows the configuration command to download and execute self-tests each time the modem card is enabled.

```
WMCS01(boot)(config-if)# radio self-test enable
```

transmit-power

Use this command to configure the antenna to transmit the specified amount of power (specified in dBm) when in operation. Privileged configuration access is required.

Note Maximum transmission power is limited by the hardware and the operating band. For the MMDS band, the maximum average transmit power is 2 Watts (+33 dBm). For the UNII band, the maximum average transmit power is 100 milliwatts (+20 dBm).

Use the **no** version of the command to reset the parameters to the defaults.

Note Use the **show running-configuration<interfaceSpec>** command to display the current setting.

Unless an error occurs, no notifications are displayed on the console.

radio transmit-power <power>
no radio transmit power

Syntax Description

power Positive number representing power stated in dBm.

Example

The following example sets the transmit power to 25dBm.

```
WMCS01(boot)(config-if)# radio transmit-power 25
```

cable-loss

Use this command to adjust the effective cable loss parameter (measured in dB) on the modem card to compensate for the measured cable loss for the cable connecting the modem card to the ODU. Privileged configuration access is required.

Note The cable loss parameter cannot be set to a value greater than 16dB.

Use the **no** version of the command to reset the cable loss parameters to the default.

Note Use the **show running-configuration<interfaceSpec>** command to display the current setting.

Unless an error occurs, no notifications are displayed on the console.

radio cable-loss <positive number>
no radio cable-loss

Example

The following example adjusts the effective cable loss parameter to 12dB.

```
WMCS01(boot)(config-if)# radio cable-loss 12
```

show imagehdr

Use this command to display details of the images to be downloaded on a single chip or on all chips.

If a particular chip is identified, the details of the image to be loaded on that chip are displayed. If no chip name is specified, the current radio configuration is retrieved for every chip on the modem card. All the images in the repository are compared. The image that provides the closest match in capability is selected, and the details of that image are displayed.

Unless an error occurs, no notifications are displayed on the console.

Name [{ *current* | *operational* }]]

Syntax Description

chipName	A character string identifying a chip.
current	Display the image header (details) for the image currently loaded on the chip.
operational	Display the image header for the image that will be loaded on the chip for the current configuration.

Example

The following example will display the image details of the chip named dspla currently loaded on the chip on the modem card in slot 3, port 0.

```
WMCS01(boot)(config-if)(offline)# show interface radio 3/0 imagehdr dspla current
```

show radio repository

Use this command to display the protocol-specific list of images in the repository. The repository is a list of current configuration images. When the modem card is initiated (no shut), this list is searched and the correct image downloaded. Privileged configuration access is required.

Unless an error occurs, no notifications are displayed on the console.

show radio repository [*header*] [*protocol*]

Syntax Description

header	Image header details associated with the list of images will also be displayed.
protocol	<{ <i>mem</i> <i>tftp</i> <i>flash</i> }>

Example

The following example lists images related to memory.

```
WMCS01(boot)(config-if)# show radio repository mem

mem:/ClarityImages/dsp1Dual.img
mem:/ClarityImages/dsp2Dual.img
mem:/ClarityImages/dsp1Single.img
```

image-add

Use this command to add the specified image to the image repository. When an image has to be downloaded according to the specified configuration, the repository is searched for an appropriate file. If found, the file is retrieved and downloaded to the hardware. Privileged configuration access is required.

Use the **no** version of the command to delete the specified image from the repository.

Unless an error occurs, no notifications are displayed on the console.

radio image-add <image>

no radio image-add <image>

Syntax Description

image	<protocol>://<host>/<directory>/<filename>
protocol	<{mem tftp flash}>
host	IP Address.
directory	Directory name. No embedded spaces accepted.
filename	Name of image file.

Example

The following command sequence selects the image displa.img at the address 200.33.33.44 to be added to the repository.

```
WMCS01(boot)(config-if)# radio image-add tftp://200.33.33.44/myDspImages/dspla.img
```

image-move

Use this command to move the specified image to the beginning of the repository list of images. When the radio card is initiated (**no shut**), the repository is searched for a firmware image whose characteristics match the current configuration. Once found, that image is downloaded. Moving an image to the beginning of the list ensures that the image is searched first when a configuration match is attempted. Privileged configuration access is required.

Unless an error occurs, no notifications are displayed on the console.

radio image-move <image>

ALPHA DRAFT - CISCO CONFIDENTIAL

Configuring a Wireless Modem Card

Syntax Description

image	<protocol>://<host>/<directory>/<filename>
protocol	<{mem tftp flash}>
host	IP Address.
directory	Directory name. No embedded spaces accepted.
filename	Name of image file.

Example

The following example selects the image dspla.img at the address 200.33.33.44 to be moved to the start of the repository list.

```
WMCS01(boot)(config-if)# radio image-move tftp://200.33.33.44/myDspImages/dspla.img
```

threshold

Use this command to configure a threshold event specification. When the specified threshold is crossed, an event of type <threshParam> will be generated and the event logged to the console. Privileged configuration access is required.

Every event is propagated to the SNMP agent by default.

Only one threshold may be defined for each of the identified <threshParam> <threshType> <dspId> combination. When a threshold is crossed, the <threshParam> <threshType> <dspId> combination identifies the threshold specification that caused the event.

For every threshold defined, antennaNum is conditional. Antenna number is applicable for the **threshParam** attributes *in*, *receivedPower*, *gainSettingsIf*, *gainSettingsRF*, and *totalGain*.

Note If an antenna number is used when a threshold is created, it must also be specified when it is deleted.

Use the **no** version of the command to terminate the event-threshold setup. The **no radio threshold** command requires the threshParam, threshType, and dspId attributes.

For each event, the <threshParam> <dspID><threshType><eventType> will be output identifying the threshold crossed.

radio threshold <threshParam> <antennaNum> [*dsp* <dspId>] <threshType> <threshValue> <repeatTime> <clearTime>

no radio threshold <threshParam> <antennaNum> [*dsp* <dspId>] <threshType>

Syntax Description

threshParam	<{{ <i>in</i> <i>inr</i> {constVariance} {timingOffset} {freqOffset} {syncStatus} {receivedPower} {gainSettingsIF} {gainSettingsRF}}>
<i>in</i>	(Interference + Noise) The interference + noise power levels are computed by the hardware on a burst-by-burst basis. Note This parameter is available for a dual antenna system only.
<i>inr</i>	(Interference + Noise Ratio) The ratio of the interference + noise power levels captured by the first antenna to the second antenna on a burst-by-burst basis. This value is specified as a log to base 2 number.
constVariance	(Constellation Variance) The average energy of the constellation error signal - the error between the received (noisy) constellation symbol and the nearest ideal constellation symbol. Constellation Variance is a measure of the Signal to Interference + Noise ratio (SINR) for that tone. On a single antenna system, it represents 1/SINR. On a dual antenna system, it represents a composite value providing 1/SINR.
timingOffset	Represents the histogram of timing delay variations detected in the radio link.
freqOffset	Represents the frequency offset calculations made to keep the receive frequency on a slave radio synchronized with the master radio.
syncStatus	Represents the synchronization status.
receivedPower	A measure of the analog signal power received by the radio system on a burst-by-burst basis.
gainSettingsIF	Represents the changes in the automatic gain control loop maintained by the hardware. This may be captured for each antenna and for the intermediate frequency (IF) module.
gainSettingsRF	Represents the changes in the automatic gain control loop maintained by the hardware. This may be captured for each antenna and for both the intermediate frequency (IF) and radio frequency (RF) modules.
totalGain	Represents the changes in the automatic gain control loop maintained by the hardware. This can be captured for each antenna.
antennaNum	{1 2}
dspId	<{dsprx1a (Receive DSP 1a) dsprx1b (Receive DSP 1b) dsprx2a (Receive DSP 2a) dsprx2b (Receive DSP2b) dsprx3a (Receive DSP 3a) dsprx3b (Receive DSP 3b) dsptx1 (Transmit DSP 1) dsptx2 (Transmit DSP 2)}>
threshType	<{ <i>highThreshold</i> <i>lowThreshold</i> <i>upChange</i> <i>downChange</i> <i>posCrossing</i> <i>negCrossing</i> }>
<i>highThreshold</i>	The upper limit for the <threshParam> being monitored.
<i>lowThreshold</i>	The lower limit for the <threshParam> being monitored.
<i>upChange</i>	The positive change limit allowed for the <threshParam> being monitored.
<i>downChange</i>	The negative change limit allowed for the <threshParam> being monitored.

ALPHA DRAFT - CISCO CONFIDENTIAL

Configuring a Wireless Modem Card

<i>posCrossing</i>	The limit that the <threshParam> should cross when it is increasing in value.
<i>negCrossing</i>	The limit that the <threshParam> should cross when it is decreasing in value.
<i>threshValue</i>	A 32-bit integral value
<i>repeatTime</i>	When radio signals are monitored, they can oscillate across a specified threshold (such as <i>highThreshold</i>) very rapidly. In such a case, an event is generated for each crossing of the threshold, which could flood the system. The <i>repeatTime</i> parameter specifies the amount of time (in seconds) the system should wait, in this case, before another event of the same type is generated.
<i>clearTime</i>	When radio signals oscillate across a threshold, it is often desirable to identify when the signal has stabilized. The <i>clearTime</i> parameter specifies how many seconds the radio signal must stay below a threshold (after crossing it once) before the system generates the clear event.

Display Elements

<i>eventType</i>	{eventSet eventRepeat eventClear}
<i>eventSet</i>	TBD
<i>eventRepeat</i>	TBD
<i>eventClear</i>	TBD

Example

The following command sequence will set up a threshold for *totalGain*. When the *totalGain* for the system on *antenna2* falls below 70, the *eventSet* event type will be generated.

```
WMCS01(boot)(config-if)# radio threshold totalGain 2 dsp dsprx1a lowThreshold 70
```

show interfaces (thresholds)

Use this command to display the display the set of currently configured thresholds on the modem card on the specified DSP. If *dspNum* is not specified, the thresholds for DSP 3 will be displayed.

Unless an error occurs, no notifications are displayed on the console.

show interfaces radio <slot/port> thresholds [dspNum]

Syntax Description

slot	Positive integer representing the Cisco uBR7200 series slot number.
port	Positive integer representing the port number on that slot.
dspNum	The DSP number.

Example

The following command will display the set of currently configured thresholds for the modem card in slot 3, port 0 on DSP number 5.

```
WMCS01(boot)(config-if)# show interfaces radio 3/0 thresholds dsp 5

Threshold AttributefreqOffset
Threshold TypedownChange
Antenna Id2
Threshold Value-100
Threshold Hysteresis Time0
Threshold Limit Time0
Threshold Statusnot in service
```

histogram

A histogram statistic is one where data is sampled every burst and the values are assigned to a fixed number of bins. Assigning a value to a bin simply increments the count for that bin. The number of bins in the histogram is specified by the NumBins parameter.

This command configures a histogram collection specification with the software. The data for the histogram is collected as soon as the command succeeds and continues until the specification is deleted using the **[no]** option or the *collectionInterval* expires. The data collected is printed out to the console at user-specified intervals. Privileged configuration access is required.

For every threshold defined, antennaNum and tone are conditional. The attributes *in*, *receivedPower*, *GainSettingsIF*, *gainSettingsRF*, and *totalGain* are applicable for antenna_num. The attributes *in*, *inr*, and *constVariance* are applicable for tone.

Use the **no** version of this command to delete any histogram configuration specification.

Use the **histdisplay** format of this command control the printing of the information to the screen.

Use the **histclear** format of this command to clear the collected histogram data.

Unless an error occurs, no notifications are displayed on the console.

```
radio histogram <statParam> [dsp <dspId>] <antenna_num> <StartBinValue> <BinDelta>
<NumBins> <BitShift> <BurstTone> [collectionInterval <interval>] [periodic <interval> sum
<{true | false}>] [tone <circulate | average | number <tone-number> ]
```

```
no radio histogram <statParam> <antenna_num> [dsp <dspId>]
```

```
radio histdisplay <statParam> <antenna_num> [dsp <dspId>] {on | off}
```

```
radio interface <slot>/<port> histclear <statParam> <antenna_num> [dsp <dspId>]
```

ALPHA DRAFT - CISCO CONFIDENTIAL

Configuring a Wireless Modem Card

Note Up to 1024 32-bit words are available for all timeline and histogram parameters on a single DSP. Each histogram requires $(\text{NumBins} + 4) * 2$ words; each timeline requires $(\text{tlSize} + 1) * 2$ words. The attributes *in*, *inr*, and *constVariance* can be captured on any DSP, while the others can be captured only on certain DSPs. Distributing histogram requests across DSPs provided better memory utilization.

Syntax Description

statParam	{ in inr constVariance timingOffset freqOffset syncStatus receivedPower gainSettingsIF gainSettingsRF totalGain codewordError }
	The radio attribute whose data is to be collected as a histogram.
in	(Interference + Noise) The interference + noise power levels are computed by the hardware on a burst-by-burst basis. Note This parameter is available for a dual antenna system only.
inr	(Interference + Noise Ratio) The ratio of the interference + noise power levels captured by the first antenna to the second antenna on a burst-by-burst basis. This value is specified as a log to base 2 number.
constVariance	(Constellation Variance) The average energy of the constellation error signal - the error between the received (noisy) constellation symbol and the nearest ideal constellation symbol. Constellation Variance is a measure of the Signal to Interference + Noise ratio (SINR) for that tone. On a single antenna system, it represents 1/SINR. On a dual antenna system, it represents a composite value providing 1/SINR.
timingOffset	Represents the histogram of timing delay variations detected in the radio link.
freqOffset	Represents the frequency offset calculations made to keep the receive frequency on a slave radio synchronized with the master radio.
syncStatus	Represents the synchronization status.
receivedPower	A measure of the analog signal power received by the radio system on a burst-by-burst basis.
gainSettingsIF	Represents the changes in the automatic gain control loop maintained by the hardware. This may be captured for each antenna and for the intermediate frequency (IF) module.
gainSettingsRF	Represents the changes in the automatic gain control loop maintained by the hardware. This may be captured for each antenna and for both the intermediate frequency (IF) and radio frequency (RF) modules.
totalGain	Represents the changes in the automatic gain control loop maintained by the hardware. This can be captured for each antenna.
codeWordError	TBD
dspId	<{ dsprx1a (Receive DSP 1a) dsprx1b (Receive DSP 1b) dsprx2a (Receive DSP 2a) dsprx2b (Receive DSP2b) dsprx3a (Receive DSP 3a) dsprx3b (Receive DSP 3b) dsptx1 (Transmit DSP 1) dsptx2 (Transmit DSP 2)}>
antenna_num	{ 1 2 }
StartBinValue	Any value below this value will not be stored in the histogram.
BinDelta	The "width" of each histogram bin. For example, if the StartBinValue is 10 and BinDelta is 50, then all values in the range 10 to 60 will be in the first bin. All values from 61 to 110 will be in bin 2, and so on.

ALPHA DRAFT - CISCO CONFIDENTIAL

Configuring a Wireless Modem Card

NumBins	The number of histogram bins to be configured for the collection.
BitShift	Specifies the number of bits by which the collected data should be shifted to the right, providing a mechanism to control overflow of the values in the histogram.
collectionInterval	Specifies, in seconds, the interval in which histogram data will be collected.
periodic	Specifies, in seconds, how often the collected histogram data should be printed to the screen. The <i>sum</i> option specifies whether successive histogram sets retrieved from the hardware should be added to replace the existing histogram data. Specifying a statistic collection to be periodic effectively reduces the size of the NumBins to half the possible amounts. The default is periodic. If the interval is 0, output is generated only at the termination of the collection.
tone	Identifies how the histogram sample should be computed when sampling a burst. A burst contains data samples from N frequency tones.
circulate	Implies successive histogram data samples should use successive frequency tones.
average	Implies successive histogram samples should average the burst data over all the frequencies and use that value.
number	Specifies that a particular tone in the burst should be used to report the histogram data. The frequency tone is passed in as a number specified in the <tone-number parameter.

Example

The following example will configure a histogram specification. The histogram collection will start as soon as the command succeeds. It will collect a histogram for interference noise ratio. The histogram will be collected on dsprx2a with starting bin of 2^{-4} (a starting ratio of 0.0625), bindelta of 1 and 32 bins in total, and no bitshift. It will cycle through the frequency tones for every successive sample. The collection will continue for 1 hour, reporting data every 30 seconds and keeping the cumulative histogram.

```
WMCS01(boot)(config-if)# radio histogram inr dsp dsprx2a -4 1 32 0 collectionInterval  
3600 circulate periodic 30 sum true
```

show interfaces (histspec)

Use this command to display the details of the histogram specifications currently configured. If none of the optional parameters are specified then all histogram specifications on the modem card are displayed.

Unless an error occurs, no notifications are displayed on the console.

```
show interfaces radio <slot/port> histspec [<statparam> <antenna_num> [dsp <dspnum>]]
```

Syntax Description

slot	Positive integer representing the Cisco uBR7200 series slot number.
port	Positive integer representing the port number on that slot.
statParam	<p>{ <i>in</i> <i>inr</i> <i>constVariance</i> <i>timingOffset</i> <i>freqOffset</i> <i>syncStatus</i> <i>receivedPower</i> <i>gainSettingsIF</i> <i>gainSettingsRF</i> <i>totalGain</i> <i>codewordError</i> }</p> <p>The radio attribute whose data is to be collected as a histogram.</p> <p>Note If the <i>statParam</i> is specified, <i>antenna_num</i> is conditionally required.</p>
in	<p>(Interference + Noise) The interference + noise power levels are computed by the hardware on a burst-by-burst basis.</p> <p>Note This parameter is available for a dual antenna system only.</p>
inr	<p>(Interference + Noise Ratio) The ratio of the interference + noise power levels captured by the first antenna to the second antenna on a burst-by-burst basis. This value is specified as a log to base 2 number.</p>
constVariance	<p>(Constellation Variance) The average energy of the constellation error signal - the error between the received (noisy) constellation symbol and the nearest ideal constellation symbol. Constellation Variance is a measure of the Signal to Interference + Noise ratio (SINR) for that tone. On a single antenna system, it represents 1/SINR. On a dual antenna system, it represents a composite value providing 1/SINR.</p>
timingOffset	Represents the histogram of timing delay variations detected in the radio link.
freqOffset	Represents the frequency offset calculations made to keep the receive frequency on a slave radio synchronized with the master radio.
syncStatus	Represents the synchronization status.
receivedPower	A measure of the analog signal power received by the radio system on a burst-by-burst basis.
gainSettingsIF	Represents the changes in the automatic gain control loop maintained by the hardware. This may be captured for each antenna and for the intermediate frequency (IF) module.
gainSettingsRF	Represents the changes in the automatic gain control loop maintained by the hardware. This may be captured for each antenna and for both the intermediate frequency (IF) and radio frequency (RF) modules.
totalGain	Represents the changes in the automatic gain control loop maintained by the hardware. This can be captured for each antenna.
codeWordError	TBD
antenna_num	<p>Positive integer specifying the antenna number (1 or 2).</p> <p>Note For every threshold defined, <i>antenna_num</i> is conditional. The attributes <i>in</i>, <i>receivedPower</i>, <i>GainSettingsIF</i>, <i>gainSettingsRF</i>, and <i>totalGain</i> are applicable for <i>antenna_num</i>.</p>
dspnum	<p>The DSP number.</p> <p>Note If the DSP number is not specified, the specification on the default DSP will be displayed.</p>

Example

The following example shows details of the histogram Constellation Variance specification configured for the modem card in slot 3, port 0 of the uBR, for DSP 3.

```
WMCS01(boot)(config-if)# show interfaces radio 3/0 histspec constV dsp 3

ClassconstVariance
Resource Id2
Start Bin Value80
Bin Delta50
Number of Bins20
Update Rate10
Collection duration100
Bit Shift16
Tone Selectionaverage
Dsp Number3
Periodic Sumtrue
Default Histfalse
```

show interfaces (histdata)

Use this command to display the collected histogram data for the identified histogram specification. The values are displayed as a *BinID:Value* pair. BinId represents the sample value contained in that bin. Value represents the count in the histogram bin.

Unless an error occurs, no notifications are displayed on the console.

```
show interfaces radio <slot/port> histData <statparam> <antenna_num> dsp <dspnum>
```

Syntax Description

slot	Positive integer representing the Cisco uBR7200 series slot number.
port	Positive integer representing the port number on that slot.
statParam	<p>{ <i>in</i> <i>inr</i> <i>constVariance</i> <i>timingOffset</i> <i>freqOffset</i> <i>syncStatus</i> <i>receivedPower</i> <i>gainSettingsIF</i> <i>gainSettingsRF</i> <i>totalGain</i> <i>codewordError</i> }</p> <p>The radio attribute whose data is to be collected as a histogram.</p> <p>Note If <statParam> is specified, <i>antenna_num</i> is conditionally required.</p>
in	<p>(Interference + Noise) The interference + noise power levels are computed by the hardware on a burst-by-burst basis.</p> <p>Note This parameter is available for a dual antenna system only.</p>
inr	<p>(Interference + Noise Ratio) The ratio of the interference + noise power levels captured by the first antenna to the second antenna on a burst-by-burst basis. This value is specified as a log to base 2 number.</p>
constVariance	<p>(Constellation Variance) The average energy of the constellation error signal - the error between the received (noisy) constellation symbol and the nearest ideal constellation symbol. Constellation Variance is a measure of the Signal to Interference + Noise ratio (SINR) for that tone. On a single antenna system, it represents 1/SINR. On a dual antenna system, it represents a composite value providing 1/SINR.</p>
timingOffset	Represents the histogram of timing delay variations detected in the radio link.
freqOffset	Represents the frequency offset calculations made to keep the receive frequency on a slave radio synchronized with the master radio.
syncStatus	Represents the synchronization status.
receivedPower	A measure of the analog signal power received by the radio system on a burst-by-burst basis.
gainSettingsIF	Represents the changes in the automatic gain control loop maintained by the hardware. This may be captured for each antenna and for the intermediate frequency (IF) module.
gainSettingsRF	Represents the changes in the automatic gain control loop maintained by the hardware. This may be captured for each antenna and for both the intermediate frequency (IF) and radio frequency (RF) modules.
totalGain	Represents the changes in the automatic gain control loop maintained by the hardware. This can be captured for each antenna.
codeWordError	TBD
antenna_num	<p>Positive integer specifying the antenna number (1 or 2).</p> <p>Note For every threshold defined, <i>antennaNum</i> is conditional. The attributes <i>in</i>, <i>receivedPower</i>, <i>GainSettingsIF</i>, <i>gainSettingsRF</i>, and <i>totalGain</i> are applicable for <i>antenna_num</i>.</p>
dspnum	<p>The DSP number.</p> <p>Note If the DSP number is not specified, the specification on the default DSP will be displayed.</p>

Example

The following example shows the command to display the histogram data for the histogram configured on the modem card in slot 3, port 0 of the uBR for DSP 3.

```
WMCS01(boot)(config-if)# show interfaces radio 3/0 histdata inr dsp 3

Histogram 4/1/8 [*=100 ] min=-2 avg=0
157      0=<0      **
137      0=<1      **
115      1=<2      **
44       2=<MAX   *
```

timeline

A timeline is a sequence of data values collected for the specified attribute. The amount of data collected is controlled by the *tlSize* parameter. The maximum size is determined by the amount of memory the hardware has.

Use this command to configure a timeline collection specification with the software. The collection starts as soon as the command succeeds, and continues until the *trigger* occurs or the *timelineStop* command is executed. Privileged configuration access is required.

For every timeline defined, *antenna_num* and *tone* are conditional. The attributes *in*, *receivedPower*, *GainSettingsIF*, *gainSettingsRF*, and *totalGain* are applicable for *antenna_num*. The attributes *in*, *inr*, and *constVariance* are applicable for *tone*.

Use the **no** version of this command to delete a timeline specification.

Use the **timelineStop** form of the command to stop a currently executing timeline specification.

Use the **timelineStart** form of the command to start a stopped timeline specification.

Unless an error occurs, no notifications are displayed on the console.

```
radio timeline <statParam> [dsp <dspId>] <antenna_num> <tlSize> [decimationFactor <df>]
[presumationShift <pss>] [print <{on | off}>] [tone <{circular | average |
number <tone-number>}>] [trigger <threshParams> <threshType> (antenna_num)
<postTrigBufMgt>]
```

```
no radio timeline <statParam> <antenna_num> [dsp <dspnum>]
```

```
radio interface radio <slot>/<port> timelineStart <statParam> (antenna_num)
[dsp <dspnum>]
```

```
radio interface radio <slot>/<port> timelineStop <statParam> (antenna_num)
[dsp <dspnum>]
```

Note Up to 1024 32-bit words are available for all timeline and histogram parameters on a single DSP. Each histogram requires $(\text{NumBins} + 4) * 2$ words; each timeline requires $(\text{tlSize} + 1) * 2$ words. The attributes *in*, *inr*, and *constVariance* can be captured on any DSP, while the others can be captured only on certain DSPs. Distributing histogram requests across DSPs provided better memory utilization.

Syntax Description

statParam	<{{in} {inr} {constVariance} {timingOffset} {freqOffset} {syncStatus} {receivedPower} {gainSettingsIF} {gainSettingsRF}}>
in	(Interference + Noise) The interference + noise power levels are computed by the hardware on a burst-by-burst basis. Note This parameter is available for a dual antenna system only.
inr	(Interference + Noise Ratio) The ratio of the interference + noise power levels captured by the first antenna to the second antenna on a burst-by-burst basis. This value is specified as a log to base 2 number.
constVariance	(Constellation Variance) The average energy of the constellation error signal - the error between the received (noisy) constellation symbol and the nearest ideal constellation symbol. Constellation Variance is a measure of the Signal to Interference + Noise ratio (SINR) for that tone. On a single antenna system, it represents 1/SINR. On a dual antenna system, it represents a composite value providing 1/SINR.
timingOffset	Represents the histogram of timing delay variations detected in the radio link.
freqOffset	This represents the frequency offset calculations made to keep the receive frequency on a slave radio synchronized with the master radio.
syncStatus	Represents the synchronization status.
receivedPower	A measure of the analog signal power received by the radio system on a burst-by-burst basis.
gainSettingsIF	Represents the changes in the automatic gain control loop maintained by the hardware. This may be captured for each antenna and for the intermediate frequency (IF) module.
gainSettingsRF	Represents the changes in the automatic gain control loop maintained by the hardware. This may be captured for each antenna and for both the intermediate frequency (IF) and radio frequency (RF) modules.
totalGain	Represents the changes in the automatic gain control loop maintained by the hardware. This can be captured for each antenna.
dspId	<{dsprx1a (Receive DSP 1a) dsprx1b (Receive DSP 1b) dsprx2a (Receive DSP 2a) dsprx2b (Receive DSP 2b) dsprx3a (Receive DSP 3a) dsprx3b (Receive DSP 3b) dsptx1 (Transmit DSP 1) dsptx2 (Transmit DSP 2)}> The DSP on which to collect the timeline data
antennaNum	{1 2} The antenna for which the timeline data should be collected.
tlSize	Positive number representing the number of values to collect

ALPHA DRAFT - CISCO CONFIDENTIAL

Configuring a Wireless Modem Card

decimationFactor	The rate at which data is received is high, so retrieving every successive data sample will likely provide little information (due to memory limitations). The decimation factor specifies how many successive data samples should be added together and reported as one data sample. If the decimation factor is not specified, every successive data sample is reported.
df	{0 .. 2^31}
presummationShift	If decimationFactor is specified, then successive data samples get added. This can potentially cause an overflow. The presummationShift value specifies the number of bits by which the data sample should be right-shifted before being added. Specifying a presummationShift value will result in less precise individual data samples but provides a mechanism to analyze the behavior over longer duration of time.
pss	(0 .. 32)
print	Specifies whether or not the collected values should be printed out when the collection completes. The default is on.
tone	Every burst of signal data contains samples from N frequency tones. This parameter identifies which of those frequency tones should be used.
circular	Implies successive data samples should use successive frequency tones.
average	Implies successive data samples should average the burst data over all the N frequencies and then use that value.
number	Specifies that data from a particular frequency in the burst should be reported.
tone-number	for <i>in</i> and <i>inr</i> { {0 .. 27} for 12MHz high, 6 MHz high } { {0 .. 33} otherwise } for constVariance { {0 .. 216} for 12MHz high } { {0 .. 198} for 12MHz med, low } { {0 .. 108} for 6MHz high } { {0 .. 99} for 6MHz med, low }
trigger	Specifies when the collection has to be stopped. The <threshParam> <threshType> (antenna_num) parameters uniquely identify a threshold specification. When this threshold is reached, the timeline will be stopped and the data collected.
threshParam	<{{ <i>in</i> } {{ <i>inr</i> } {constVariance} {timingOffset} {freqOffset} {syncStatus} {receivedPower} {gainSettingsIF} {gainSettingsRF}}>
in	(Interference + Noise) The interference + noise power levels are computed by the hardware on a burst-by-burst basis. Note This parameter is available for a dual antenna system only.
inr	(Interference + Noise Ratio) The ratio of the interference + noise power levels captured by the first antenna to the second antenna on a burst-by-burst basis. This value is specified as a log to base 2 number.

constVariance	(Constellation Variance) The average energy of the constellation error signal - the error between the received (noisy) constellation symbol and the nearest ideal constellation symbol. Constellation Variance is a measure of the Signal to Interference + Noise ratio (SINR) for that tone. On a single antenna system, it represents 1/SINR. On a dual antenna system, it represents a composite value providing 1/SINR.
timingOffset	Represents the histogram of timing delay variations detected in the radio link.
freqOffset	This represents the frequency offset calculations made to keep the receive frequency on a slave radio synchronized with the master radio.
syncStatus	Represents the synchronization status.
receivedPower	A measure of the analog signal power received by the radio system on a burst-by-burst basis.
gainSettingsIF	Represents the changes in the automatic gain control loop maintained by the hardware. This may be captured for each antenna and for the intermediate frequency (IF) module.
gainSettingsRF	Represents the changes in the automatic gain control loop maintained by the hardware. This may be captured for each antenna and for both the intermediate frequency (IF) and radio frequency (RF) modules.
totalGain	Represents the changes in the automatic gain control loop maintained by the hardware. This may be captured for each antenna.
threshType	<{ <i>highThreshold</i> <i>lowThreshold</i> <i>upChange</i> <i>downChange</i> <i>posCrossing</i> <i>negCrossing</i> }>
<i>highThreshold</i>	An upper limit for the <threshParam> being monitored.
<i>lowThreshold</i>	A lower limit for the <threshParam> being monitored.
<i>upChange</i>	The positive change limit allowed for the <threshParam> being monitored.
<i>downChange</i>	The negative change limit allowed for the <threshParam> being monitored.
<i>posCrossing</i>	The limit that the <threshParam> should cross when it is increasing in value.
<i>negCrossing</i>	The limit that the <threshParam> should cross when it is decreasing in value.
postTrigBufMgt	Specifies the position of the trigger in the data collected. If it is 1, then most of the data collected prior to the trigger is returned. If it is 2, most of the data returned is captured after the occurrence of the trigger.

Example

The following example configures a timeline specification. The collection process starts as soon as the command succeeds. The *inr* parameter will be monitored. 640 values will be collected in total.

Of the *n* tones in a burst, the average value of all the tones (for the burst) is retrieved as one data sample. Each data sample will be right shifted by 2 bits. 20 successive (right-shifted) data samples will be added together and reported as one value (of the 640 values in total).

When the threshold `<inr>` `<lowThreshold>` `<2>` is reached, the collection will stop and the results will be printed out.

```
WMCS01(boot)(config-if)# radio timeline inr 640 dec 20 pre 2 tone average trigger inr  
lowThreshold 2
```

show interfaces (tlspec)

Use this command to display the details of the timeline specifications currently configured. If none of the optional parameters are specified then all the timeline specifications on the modem card are displayed. If the `<statParam>``<antenna_num>` combination only is specified, then the configuration setup on the default will be displayed. if the `[dsp <dspId>]` parameter is specified, then the configurations on that DSP will be displayed.

Unless an error occurs, no notifications are displayed on the console.

```
show interfaces radio <slot/port> tlspec [<statParam> (antenna_num) [dsp <dspId>]]
```

Syntax Description

slot	Positive integer representing the Cisco uBR7200 series slot number.
port	Positive integer representing the port number on that slot.
statParam	<{{ <i>in</i> } { <i>inr</i> } { constVariance } { timingOffset } { freqOffset } { syncStatus } { receivedPower } { gainSettingsIF } { gainSettingsRF } }>
in	(Interference + Noise) The interference + noise power levels are computed by the hardware on a burst-by-burst basis. Note This parameter is available for a dual antenna system only.
inr	(Interference + Noise Ratio) The ratio of the interference + noise power levels captured by the first antenna to the second antenna on a burst-by-burst basis. This value is specified as a log to base 2 number.
constVariance	(Constellation Variance) The average energy of the constellation error signal - the error between the received (noisy) constellation symbol and the nearest ideal constellation symbol. Constellation Variance is a measure of the Signal to Interference + Noise ratio (SINR) for that tone. On a single antenna system, it represents 1/SINR. On a dual antenna system, it represents a composite value providing 1/SINR.
timingOffset	Represents the histogram of timing delay variations detected in the radio link.
freqOffset	Represents the frequency offset calculations made to keep the receive frequency on a slave radio synchronized with the master radio.
syncStatus	Represents the synchronization status.
receivedPower	A measure of the analog signal power received by the radio system on a burst-by-burst basis.
gainSettingsIF	Represents the changes in the automatic gain control loop maintained by the hardware. This may be captured for each antenna and for the intermediate frequency (IF) module.
gainSettingsRF	Represents the changes in the automatic gain control loop maintained by the hardware. This may be captured for each antenna and for both the intermediate frequency (IF) and radio frequency (RF) modules.
totalGain	Represents the changes in the automatic gain control loop maintained by the hardware. This can be captured for each antenna.
antennaNum	{ 1 2 } The antenna for which the timeline data should be collected.
dspId	<{ dsprx1a (Receive DSP 1a) dsprx1b (Receive DSP 1b) dsprx2a (Receive DSP 2a) dsprx2b (Receive DSP 2b) dsprx3a (Receive DSP 3a) dsprx3b (Receive DSP 3b) dsptx1 (Transmit DSP 1) dsptx2 (Transmit DSP 2) }> The DSP on which to collect the timeline data

Example

The following example displays the *inr* timeline specification configured for the modem card in port

3, slot 0 of the uBR.

```
WMCS01(boot)(config-if)# show interfaces radio 3/0 tlspec inr

ClassInr
Resource Id1
Buffer size50
Number of buffers20
Collection method30
Tone Selectionaverage
Stop threshold attributein
Stop threshold typedownChange
Stop antenna number1
Print optionsoff
Dsp Number3
Default T1false
```

show interfaces (tldata)

Use this command to display the timeline data collected for the identified specifications.

Unless an error occurs, no notifications are displayed on the console.

show interfaces radio <slot/port> tldata <statParam> (antenna_num) dsp <dspId>

Syntax Description

slot	Positive integer representing the Cisco uBR7200 series slot number.
port	Positive integer representing the port number on that slot.
statParam	<{{ <i>in</i> } { <i>inr</i> } { constVariance } { timingOffset } { freqOffset } { syncStatus } { receivedPower } { gainSettingsIF } { gainSettingsRF } }>
in	(Interference + Noise) The interference + noise power levels are computed by the hardware on a burst-by-burst basis. Note This parameter is available for a dual antenna system only.
inr	(Interference + Noise Ratio) The ratio of the interference + noise power levels captured by the first antenna to the second antenna on a burst-by-burst basis. This value is specified as a log to base 2 number.
constVariance	(Constellation Variance) The average energy of the constellation error signal - the error between the received (noisy) constellation symbol and the nearest ideal constellation symbol. Constellation Variance is a measure of the Signal to Interference + Noise ratio (SINR) for that tone. On a single antenna system, it represents 1/SINR. On a dual antenna system, it represents a composite value providing 1/SINR.
timingOffset	Represents the histogram of timing delay variations detected in the radio link.
freqOffset	Represents the frequency offset calculations made to keep the receive frequency on a slave radio synchronized with the master radio.
syncStatus	Represents the synchronization status.
receivedPower	A measure of the analog signal power received by the radio system on a burst-by-burst basis.
gainSettingsIF	Represents the changes in the automatic gain control loop maintained by the hardware. This may be captured for each antenna and for the intermediate frequency (IF) module.
gainSettingsRF	Represents the changes in the automatic gain control loop maintained by the hardware. This may be captured for each antenna and for both the intermediate frequency (IF) and radio frequency (RF) modules.
totalGain	Represents the changes in the automatic gain control loop maintained by the hardware. This can be captured for each antenna.
antennaNum	{ 1 2 } The antenna for which the timeline data should be collected.
dspId	<{ dsprx1a (Receive DSP 1a) dsprx1b (Receive DSP 1b) dsprx2a (Receive DSP 2a) dsprx2b (Receive DSP 2b) dsprx3a (Receive DSP 3a) dsprx3b (Receive DSP 3b) dsptx1 (Transmit DSP 1) dsptx2 (Transmit DSP 2) }> The DSP on which to collect the timeline data

Example

The following example will display the timeline *inr* data for the modem card installed in slot 3, port

0 of the uBR.

```
WMCS01(boot)(config-if)# show interfaces radio 3/0 tldata inr
```

```
Number of Points Captured=100 Trigger Location=54
0   :0000 0000 0000 0000 0000 0000 0000 0000 0000 0000
10  :0000 0000 0000 0000 0000 0000 0000 0000 0000 0000
20  :0000 0000 0000 0000 0000 0000 0000 0000 0000 0000
30  :0000 0000 0000 0000 0000 0000 0000 0000 0000 0000
40  :0000 0000 0000 0000 0000 0000 0000 0000 0000 0000
50  :FFFFFF FFFFFFFF 0000 0000 0000 0000 0000 0001 FFFFFFFF FFFFFFFF
60  :0000 0002 FFFFFFFF FFFFFFFF 0000 0001 0000 0000 0000 0000
70  :0000 0000 0000 0001 FFFFFFFF FFFFFFFF 0000 0000 0000 0001
80  :FFFFFF FFFFFFFF 0000 0000 0000 0001 FFFFFFFF FFFFFFFF 0000 0000
```

automatic repeat query (arq)

Use these commands to configure the Automatic Repeat Query mechanism on the modem card to trade limited link bandwidth for redundancy in the link. The extra redundancy provides better error correction for a more stable link. Privileged configuration access is required.

Use the **no** form of the command to reset the current ARQ settings to the default values.

Use the **radio arq** *<{on | off}>* command to turn on or off the ARQ feature on the link.

Use the **radio arq reset** command to reset the current ARQ values to consistent settings based on the channel-parameter configuration.

Note If ARQ is turned off, the radio link may not get established in adverse environments.

Unless an error occurs, no notifications are displayed on the console.

```
radio arq <pctBw> <dataLatency> {BurstSize}
no radio arq
radio arq <{on | off}>
radio arq reset
```

Syntax Description

pctBw	Positive number representing the peak percentage of the link bandwidth to be used for the ARQ mechanism. The value may be 1 to 10000 representing 0.01 to 100 percent of the available bandwidth.
dataLatency	Positive number specifying the expected latency value for normal data. Latency values are measured in milliseconds.
BurstSize	Positive number specifying the maximum number of consecutive ARQ codewords that will be transmitted. Smaller values result in lower jitter.

Example

The following command sequence sets the ARQ mechanism for 0.01% of the bandwidth, a 20 millisecond latency value, and 20 consecutive ARQ codewords.

```
WMCS01(boot)(config-if)# radio arq 1 20 20
```

show interfaces (arq)

Use this command to display the current ARQ configuration on the modem card.

Unless an error occurs, no notifications are displayed on the console.

show interfaces radio <slot/port> arq

Syntax Description

slot Positive integer representing the Cisco uBR7200 series slot number.

port Positive integer representing the port number on that slot.

Display Elements

pctBW	The maximum percent link bandwidth being used for ARQ.
dataLatency	Hardware will restrict the maximum latency for packet data to this value.
BurstSize	Currently configured burst size.
OnOff	Whether ARQ is turned on or off.
ARQPeakBitRate	The maximum possible peak bit rate that the link can handle given the current channel-parameter and ARQ settings.
ARQMinBitRate	The minimum bit rate that may be seen on the link given the current channel-parameter and ARQ settings.
ARQMaxLatencyJitter	The Maximum jitter expected on this link given the current configuration.

Example

The following command will display the ARQ configuration for the modem card in slot 3, port 0.

```
WMCS01(boot)(config-if)# show interfaces radio 3/0 arq
```

(Display TBD)

loopback

Use this command to configure the specified module to loopback its data path at the specified subsystem. If no optional parameters are specified, a local IF loopback is established. Privileged configuration access is required.

Use the **no** form of the command to remove the loopback specification.

Unless an error occurs, no notifications are displayed on the console.

radio loopback [local <module>]

no radio loopback [local<module>]

Syntax Description

```
module <{codec | fir | if | rf | framer}>
```

Example

The following example initiates a local RF loopback

```
WMCS01(boot)(config-if)# radio loopback local rf
```

show interfaces (loopback)

Use this command to display the set of loopbacks currently in effect for the specified modem card.

Unless an error occurs, no notifications are displayed on the console.

show interfaces radio <slot>/<port> loopback

Syntax Description

slot Positive integer representing the Cisco uBR7200 series slot number.

port Positive integer representing the port number on that slot.

Example

The following example displays the set of loopbacks currently in effect for the modem card in slot 3, port 0 of the uBR.

```
WMCS01(boot)(config-if)# show interfaces radio 3/0 loopback
```

```
(display TBD)
```

privacy

Use these commands to configure the baseline encryption options provided by the wireless modem card. The radio designated as the master radio controls privacy authorization and encryption key distribution. The radio designated as the slave radio tracks the master radio's signals. The default is on. Privileged configuration access is required.

Use the enable command to enable baseline privacy options. Use the other commands to configure timeout values. When privacy is enabled, the timeout values determine how long the master or the slave radio will wait for either authentication or encryption keys to be revalidated. If this revalidation fails, meaningful communication between master and slave radios will not be possible.

Use the **no** form of the commands to turn privacy options off.

Note These parameters can only be changed when the radio link is down (**shut**).

Unless an error occurs, no notifications are displayed on the console.

```
radio privacy enable  
radio privacy auth-wait-time <secs>  
radio privacy reauth-wait-time <secs>
```

radio privacy auth-grace-time <secs>
radio privacy op-wait-time <secs>
radio privacy rekey-wait-time <secs>
radio privacy tek-grace-time <secs>
radio privacy auth-lifetime <secs>
radio privacy tek-lifetime <secs>
no radio privacy

Syntax Description

auth-wait-time	The amount of time the slave radio will wait before issuing a new authorization request to the master radio.
reauth-wait-time	The amount of time the slave radio will wait before issuing a new reauthorization request to the master.
auth-grace-time	Grace time for an authorization key. The slave radio is expected to start trying to get a new authorization key beginning auth-grace-time seconds before the authorization key actually expires.
op-wait-time	TBD
rekey-wait-time	The amount of time (in seconds) that the slave radio waits before issuing a new request to the master radio for an encryption key.
tek-grace-time	Grace time for a traffic encryption key (TEK). The slave radio is expected to start trying to get a new TEK beginning tek-grace-time seconds before the traffic encryption key actually expires.
auth-lifetime	The lifetime (in seconds) the master radio assigns to an authorization key for the slave radio.
tek-lifetime	The lifetime (in seconds) assigned to traffic encryption keys by the master radio.

Example

The following command will configure baseline privacy.

```
WMCS01(boot)(config-if)# radio privacy enable
```

metrics alarm (link metrics thresholds)

Link metrics represents parameters measured during the operation/non-operation of the radio link that provide a quantitative measure of how well the radio link is performing over time. When the radio link is synchronized, the measurement parameters used are error free second (EFS), codeword error second (ES), codeword severely errored second (SES), codeword consecutively errored second (CSES), codeword degraded second (DS), and codeword degraded minute (DM).

Note This command must be used with care, as arbitrary changes will distort the performance metrics that get reported for the radio link.

Use the **radio metrics alarm CWErr** command to configure thresholds that determine how the metrics are handled. Use the **radio metrics Alarm 1Hr** command to configure limits on the ES, SES, CSES, and DM. When these limits are exceeded in a one hour period, alarms will be generated to notify the user. Use the **radio metrics Alarm 24Hr** command to configure limits on the ES, SES, CSES, and Dm. When these limits are exceeded in a 24 hour period, alarms will be generated to notify the user. Privileged configuration access is required.

Use the **no** version of the commands to force the thresholds back to the default values.

Use the **show interfaces** version of the command to display the currently configured codeword error, 24 hour alarm or 1 hour threshold settings.

Unless an error occurs, minor alarms are generated and displayed on the console whenever the specified one hour or 24 hour thresholds are exceeded.

radio metrics Alarm CWErr <ESThresh> <DSThresh> <SESThresh> <CSESThresh>

radio metrics Alarm 24Hr <ESLimit> <SESLimit> <CSESLimit> <DMLimit>

radio metrics Alarm 1Hr <ESLimit> <SESLimit> <CSESLimit> <DMLimit>

no radio metrics Alarm CWErr

no radio metrics Alarm 24Hr

no radio metrics Alarm 1Hr

show interfaces radio <slot/port> CwErrThresh

show interfaces radio <slot/port> 24HrThresh

show interfaces radio <slot/port> 1HrThresh

Syntax Description

ESThresh	Specifies the number of codeword errors that must be detected within a one second interval for that second to be treated as a Codeword Errored Second.
DSThresh	Specifies the number of codeword errors that must be detected within a one second interval for that second to be treated as a Codeword Degraded Second.
SESThresh	Specifies the number of codeword errors that must be detected within a one second interval for that second to be treated as a Codeword Severely Errored Second.
CSESThresh	Specifies the number of consecutive codeword severely errored seconds that must be detected for the sequence to be treated as one codeword consecutive severely errored second (CSES).
ESLimit	Specifies the number of codeword errored seconds that should be detected within the specified time period (one operational hour or 24 operational hours), after which the ESLimit minor alarm will be generated.
SESLimit	Specifies the number of codeword severely errored seconds that should be detected within the specified time period (one operational hour or 24 operational hours), after which the SESLimit minor alarm will be generated.
CSESLimit	Specifies the number of codeword consecutively severely errored seconds that should be detected within the specified time period (one operational hour or 24 operational hours), after which the CSESLimit minor alarm will be generated.
DMLimit	Specifies the number of codeword degraded minutes that should be detected within the specified period (one operational hour or 24 operational hours), after which the DMLimit minor error alarm will be generated.
slot	Positive integer representing the Cisco uBR7200 series slot number.
port	Positive integer representing the port number on that slot.

Example

The following example will configure the link so that:

- If more than 3 codeword errors are detected per second, that second will be treated as an errored second.
- If more than 30 codeword errors are detected in one second, that second will be flagged as a degraded second.
- If more than 150 codeword errors are detected in one second, that second will be flagged as a severely errored second.
- If more than 4 codeword severely errored seconds are detected in sequence, that sequence is flagged as a 1 codeword severely errored second.

```
WMCS01(boot)(config-if)# radio metrics Alarm CWErr 3 30 150 4
```

The following example will configure the link alarms so that:

- If the link has codeword errors 66.67% of the time in one hour, an alarm will be generated.
- If the link was severely errored more than 10% of the time, an alarm will be generated.

- If the link was consecutively errored for more than 1% of the time, an alarm will be generated.
- If the link had more than 5 degraded minutes, an alarm will be generated.

```
WMCS01(boot)(config-if)# radio metrics Alarm 1Hr 2400 360 36 5
```

show interfaces (LinkMetrics)

Link metrics represents parameters measured during the operation/non-operation of the radio link that provide a quantitative measure of how well the radio link is performing over time. All link metrics are measured in terms of Codewords. A Codeword is a unit of data transmission over the radio link. It contains information such as user's data, error correction, and collation information so that successive Codewords may be reconstructed at the receiving end into the user's data.

There are two classes of link metrics:

- 1 Metrics that quantify how the link performed since the system was powered on:

show interface radio <slot/port> linkMetrics

(provides information since power on)

show interface radio <slot/port> 24HrMetrics

(provides information for the past 24 hours)

- 2 Metrics that quantify how the link performed when the two ends of the link were synchronized:

show interface radio <slot/port> radio 1HrMetrics [delta] [numVals]

(provides details for the last 24 hours)

show interface radio <slot/port> radio 1MinMetrics [delta] [numVals]

(provides details for the last 60 minutes)

show interface radio <slot/port> radio 1SecMetrics [delta] [numVals]

(provides details for the last 60 seconds)

show interface radio <slot/port> radio 1TickMetrics [delta] [numVals]

(provides details for the last N hardware ticks)

Three categories of metrics are maintained by the radio link's software and hardware:

- 1 Cumulative metrics where only one set is maintained for the entire collection period. LinkMetrics and 24HrMetrics are in this category.
- 2 Cumulative metrics where a table of values is maintained, providing metrics relating to the time period when the two ends of the link are synchronized. 1HrMetrics and 1MinMetrics are in this category.
- 3 Cumulative metrics where a table of values is maintained, providing metrics maintained by the hardware which is used to derive the information in categories 1 and 2. 1SecMetrics and 1TickMetrics are in this category.

Syntax Description

slot	Positive integer representing the Cisco uBR7200 series slot number.
port	Positive integer representing the port number on that slot.
delta <true false >	Prints the delta between successive values in the tables. The default value is false.
numVals	Positive number specifying the last numVal entries in the table. If numVals is not specified, all the values in the table will be printed.

Display Elements

When *linkMetrics* are requested, the following values are displayed:

Available Seconds	The number of Operational Seconds, since the link was powered up, that the link was not codeword severely errored. (Error Free Seconds + Errored Seconds)
Unavailable Seconds	The number of Link Up seconds, since the system was powered up, that the link was unavailable for use after the first successful link synchronization. (link Up Seconds - Available Seconds)
SyncLossSeconds	The number of Link Up Seconds during which the radio link was out of sync with the remote after the first successful establishment of synchronization.
PctErrorFreeSeconds	Represented as a percentage, the ratio of the cumulative Codeword Error Free Seconds (EFS) to the total Available seconds (cwrAvailableSeconds), for the link since the system was rebooted. The percentage is expressed as a value 1 to 10000 representing 0.01 percent to 100 percent.
PctErrored Seconds	Represented as a percentage, the ratio of the cumulative Codeword Errored Seconds (CES) to the total Available Seconds (cwrAvailableSeconds) for this radio link. The percentage is expressed as a value 1 to 10000, representing 0.01 percent to 100 percent.
PctSeverelyErroredSeconds	Represented as a percentage, the ratio of cumulative Codeword Severely Errored Seconds (SES) to the total Available seconds for this link. The percentage is expressed as a value 1 to 10000, representing 0.01 percent to 100 percent.
PctAvailSeconds	Represented as a percentage, the ratio of Available Seconds (cwrAvailableSeconds) to the total Link Up seconds for this radio link. The percentage is expressed as a value 1 to 10000, representing 0.01 percent to 100 percent.
PctCwDegradeMinutes	Represented as a percentage the ratio of codeword Degraded Minutes to the to the total Link Up seconds for this radio link. The percentage is expressed as a value 1 to 10000, representing 0.01 percent to 100 percent.
SyncSuccessCount	The number of times the radio link established synchronization with the remote since power on.

ALPHA DRAFT - CISCO CONFIDENTIAL

Configuring a Wireless Modem Card

SyncFailureCount	The number of times the link failed to establish synchronization with the remote and automatically tried again since power on.
ManagedSyncLoss	The number of times the radio link layer was shut down by operator intervention since power on.
AutomaticSyncLoss	The number of times the radio link layer lost synchronization with the remote end without manual intervention.
LastSyncSuccessTime	Elapsed time since the radio link successfully synchronized with the remote end.
LastSyncFailTime	Elapsed time since the radio link lost synchronization with the remote end.
EffectivePhyDataRate	The effective data throughput of this link. For configured data throughput, this represents the data throughput being achieved on the link. If ARQ is turned on, this number may be less than the total expected throughput.
PctEffectivePhyDataRate	The effective data throughput of this link. For configured data throughput, this represents, as a percentage, the data throughput being achieved on the link. If ARQ is turned on, this number may be less than 100%. The percentage is expressed as an integer between 1 and 10000, where 1 represents 0.01%.

When *24hrMetrics* are requested, the following values are displayed:

24HrUpdateTime	The delta time since power-on and the time at which this entry is updated.
24HrErrorFreeSeconds	The number of Codeword Error Free Seconds (EFS) detected over the most recent 24 Operational Hours.
24HrErroredSeconds	The number of Codeword Error Seconds (ES) detected over the most recent 24 Operational Hours.
24HrSevErroredSeconds	The number of Codeword Severely Errored Seconds (SES) detected over the most recent 24 Operational Hours.
24HrConsecSvErrSeconds	The number of Codeword Consecutively Severely Errored Seconds (CSES) detected over the most recent 24 Operational Hours.
24HrDegradedMinutes	The number of Codeword Degraded Minutes (DM) detected over the most recent 24 Operational Hours.
24HrTotalErroredCodewords	The total number of raw errored codewords detected on this link over the most recent 24 Operational Hours.
24HrTotalCodewords	The total number of raw codewords received on this link over the most recent 24 Operational Hours.

When *1HrMetrics* are requested, the following values are displayed:

1HrUpdateTime	The sysUptime.0 at which time this entry was updated.
1HrErrorFreeSeconds	The sum of the number of Error Free Seconds (EFS) detected in the last 1 hour and the previous 1 hour entry.

1HrErroredSeconds	The sum of the number of Codeword Errored Seconds (ES) detected over a duration of 1 hour and the previous 1 hour entry.
1HrSevErroredSeconds	The sum of Codeword Severely Errored Seconds (SES) detected over a duration of 1 hour and the previous 1 hour entry.
1HrConsSvErrSeconds	The sum of Codeword Consecutive Severely Errored Seconds (CSES) detected over a duration of 1 hour and the previous 1 hour entry.
1HrDegradedMinutes	The sum of Codeword Degraded Minutes detected over a duration of 1 hour and the previous 1 hour entry.
1HrErroredCodewords	The sum of errored codewords detected over a duration of 1 hour and the previous 1 hour entry.
1HrTotalCodewords	The sum of codewords detected over a duration of 1 hour and the previous 1 hour entry.

When *1MinMetrics* are requested, the following values are displayed:

1MinUpdateTime	The sysUptime.0 at which time this entry was updated.
1MinErrorFreeSeconds	The sum of the number of Error Free Seconds (EFS) detected in the last 1 minute and the previous 1 minute entry.
1MinErroredSeconds	The sum of the number of Codeword Errored Seconds (ES) detected over a duration of 1 minute and the previous 1 minute entry.
1MinSevErroredSeconds	The sum of Codeword Severely Errored Seconds (SES) detected over a duration of 1 minute and the previous 1 minute entry.
1MinConsSvErrSeconds	The sum of Codeword Consecutive Severely Errored Seconds (CSES) detected over a duration of 1 minute and the previous 1 minute entry.
1MinDegradedMinutes	The sum of Codeword Degraded Minutes detected over a duration of 1 minute and the previous 1 minute entry.
1MinErroredCodewords	The sum of errored codewords detected over a duration of 1 minute and the previous 1 minute entry.
1HrTotalCodewords	The sum of codewords detected over a duration of 1 minute and the previous 1 minute entry.

When *1SecMetrics* are requested, the following values are displayed:

1SecRxCodewords	The sum of the total number of codewords received by this radio link over the last 1 second and the previous 1 second entry.
1SecRSCodewordErrors	The sum of the total number of uncorrectable codewords emitted by the Reed-Solomon error correction engine and the previous 1 second entry.
1SecArqCodewordErrors	The sum of the total number of uncorrectable codewords emitted by the Automatic Repeat Query error correction engine and the previous 1 second entry. Any error not corrected by the ARQ engine represents the errors that the radio-link actually emits to the next higher protocol layer.

ALPHA DRAFT - CISCO CONFIDENTIAL

Configuring a Wireless Modem Card

1SecRxRr Count	The sum of the number of unique Retransmit Requests (RRs) that were generated by the receive side of the local end during the last second and the previous 1 second entry. This provides an indication of how error free the receive side of this radio link is.
1SecRxRrEventCount	The sum of the number of RRs that were serviced during the last second and the previous 1 second entry. A serviced RR is one that is actually attached to a outgoing codeword header.
1SecTxArqCount	The sum of the number of non-unique ARQs that were received by the transmit side of the local end during the last second and the previous 1 second entry. This provides an indication of how error free the transmissions of the local end are being received by the remote end.
1SecTxArqEventCount	The sum of the number of ARQs that were serviced during the last second and the previous 1 second entry. A serviced ARQ results in a re-transmitted codeword.
1SecCorrectedSyncByteErrs	The sum of the total number of sync byte errors that were corrected over the last 1 second and the previous 1 second entry.
1SecConsecutiveCwErrs	The sum of the total number of consecutive codeword errors received over the last 1 second and the previous 1 second entry.

When *ITickMetrics* are requested, the following values are displayed:

1TickRxCodewords	The sum of the total number of codewords received by this radio link over the last 1 hardware tick and the previous 1 tick entry.
1TickRSCodewordErrors	The sum of the total number of uncorrectable codewords emitted by the Reed-Solomon error correction engine and the previous 1 tick entry.
1TickArqCodewordErrors	The sum of the total number of uncorrectable codewords emitted by the Automatic Repeat Query error correction engine and the previous 1 tick entry. Any error not corrected by the ARQ engine represents the errors that the radio-link actually emits to the next higher protocol layer.
1TickRxRr Count	The sum of the number of unique Retransmit Requests (RRs) that were generated by the receive side of the local end during the last hardware tick and the previous 1 tick entry. This provides an indication of how error free the receive side of this radio link is.
1TickRxRrEventCount	The sum of the number of RRs that were serviced during the last hardware tick and the previous 1 tick entry. A serviced RR is one that is actually attached to a outgoing codeword header.
1TickTxArqCount	The sum of the number of non-unique ARQs that were received by the transmit side of the local end during the last hardware tick and the previous 1 tick entry. This provides an indication of how error free the transmissions of the local end are being received by the remote end.
1TickTxArqEventCount	The sum of the number of ARQs that were serviced during the last hardware tick and the previous 1 tick entry. A serviced ARQ results in a re-transmitted codeword.

1TickCorrectedSyncByteErrs	The sum of the total number of sync byte errors that were corrected over the last 1 hardware tick and the previous 1 tick entry.
1TickConsecutiveCwErrs	The sum of the total number of consecutive codeword errors received over the last 1 hardware tick and the previous 1 tick entry.

Example

The following command will display the performance of the link since power-on.

```
WMCS01(boot)(config-if)# show interface radio 3/0 linkMetrics
```

led

Use this command to manually highlight specific conditions on a specified modem card using the four LEDs on the card. Privileged configuration access is required.

Use the **no** form of the command to reset the settings of the LED to the default values.

Use the **show interface <slot/port>** form of the command to display the current configuration and the state of the LEDs.

Unless an error occurs, no notifications are displayed on the console.

```
radio led <{<latchLeds><latchLedOptions> | <otherLeds><otherLedOptions>}>
```

```
no radio led <{<latchLeds> | <otherLeds>}>
```

```
show interface radio <slot/port> led
```

ALPHA DRAFT - CISCO CONFIDENTIAL

Configuring a Wireless Modem Card

Syntax Description

<i>latchLeds</i>	<{ <i>major_alarm_led</i> <i>minor_alarm_led</i> }>
<i>major_alarm_led</i>	Indicates the occurrence of a major alarm in the radio subsystem. This LED can be configured to be automatic or latched.
<i>minor_alarm_led</i>	Indicates the occurrence of a minor alarm in the radio subsystem. This LED can be configured to be automatic or latched.
<i>latchLedOptions</i>	<{ <i>automatic</i> <i>latch</i> <i>off</i> <i>solidGreen</i> <i>solidYellow</i> <i>blinkGreen</i> <i>blinkYellow</i> <i>blinkBoth</i> }>
<i>automatic</i>	The system controls the behavior of the LED at all times.
<i>latch</i>	The system will turn the LED on indicating an alarm condition; the operator must turn it off. The operator can control the color that the LED will display when it is turned on.
<i>off</i>	This forces the LED to turn off.
<i>solidGreen</i>	When the LED is turned on, it will be green in color.
<i>solidYellow</i>	When the LED is turned on, it will be yellow in color.
<i>blinkGreen</i>	When the LED needs to be turned on, it will blink green.
<i>blinkYellow</i>	When the LED needs to be turned on, it will blink yellow.
<i>blinkBoth</i>	When the LED needs to be turned on, it will blink alternately yellow and green.
<i>otherLeds</i>	<{ <i>carrier_led</i> <i>service_led</i> }>
<i>carrier_led</i>	Represents the state of the radio link. This LED cannot be latched, but the operator can turn these LEDs on or off manually.
<i>service_led</i>	Indicates the service availability on this radio link. This LED cannot be latched, but the operator can turn these LEDs on or off manually.
<i>otherLedOptions</i>	<{ <i>off</i> <i>solidGreen</i> <i>solidYellow</i> <i>blinkGreen</i> <i>blinkYellow</i> <i>blinkBoth</i> }>

Example

The following command sets the behavior of the major alarm LED to be controlled by the system at all times.

```
WMCS01(boot)(config-if)# radio led major_alarm_led automatic
```

image-override

Use this command to attach a specified image file name to a specified chip. When an image has to be downloaded to this chip, the configuration matching logic is ignored and the currently attached image is downloaded. Privileged configuration access is required.

Use the **no** form of the command to remove the override.

Unless an error occurs, no notifications are displayed on the console.

```
radio image_override <chipName><image>  
no radio dbg image_override
```

Syntax Description

chipName	A character string identifying a chip.
image	<protocol>://<host>/<directory>/<filename>
protocol	< mem ftp flash >
host	IP Address.
directory	Directory name. (No embedded spaces accepted.)
filename	Name of image file.

Example

(explanation of example here)

```
WMCS01(boot)(config-if)# radio image_override TBD
```

show interface (image-override)

Use this command to display a list of chips and their associated overridden images.

Unless an error occurs, no notifications are displayed on the console.

```
show interface radio <slot>/<port> image-override
```

Syntax Description

slot	Positive integer representing the Cisco uBR7200 series slot number.
port	Positive integer representing the port number on that slot.

Example

The following command will display the list of chips and associated overridden images for the modem card in slot 3, port 0 of the uBR.

```
WMCS01(boot)(config-if)# show interface radio 3/0 image-override  
  
dsp1a: ftp://222.33.33.44/myDspImages/test1.img  
dsp2b: ftp://222.33.33.44/myDspImages/test2.img
```

snapshot

A snapshot is a specified amount of data captured from the modem card. Use these commands to manipulate snapshots on the modem card. Privileged configuration access is required.

Use the **radio snapshot** command to create a snapshot specification. When this command is issued, the specification is created and the data is captured.

ALPHA DRAFT - CISCO CONFIDENTIAL

Configuring a Wireless Modem Card

Use the **no** form of the command to delete a specification and its associated data.

Use the **show interface radio snapshot** command to display the configured snapshot information.

Use the **show interface radio snapdata** command to display the data captured for the snapshot specification.

Use the **radio interface radio snapcapture** command to capture another snapshot on the identified DSP. The snapshot specification already configured on the DSP will be used.

Use the **radio interface radio snapclear** command to clear the data collected for the specified snapshot on the identified DSP.

Up to four different snapshot types can be requested at once. When more than one snapshot is requested in a command, all of them will be initiated on the same DSP.

radio snapshot <dspId> <snapshotType>

no radio snapshot <dspId> <snapshotType>

show interface radio <slot>/<port> <{snapshot / snapdata}> <dspId>

radio interface radio <slot>/<port> snapcapture <dspId>

radio interface radio <slot>/<port> snapclear <dspId>

Syntax Description

dspId	<{dsprx1a Receive DSP 1a dsprx1b Receive DSP 1b dsprx2a Receive DSP 2a dsprx2b Receive DSP 2b dsprx3a Receive DSP 3a dsprx3b Receive DSP 3b dsptx1 Transmit DSP 1 dsptx2 Transmit DSP 2}>
shapshotType	Unsigned number. Up to four different snapshot types may be requested at once. When more than one snapshot is requested in a command, all snapshots will be captured from the same DSP. See snapshot type definitions below.
rx-rawburst-ant1-y1n (0x01)	Represents a snapshot of the received signal for RF resource 1. For every sample, the real and imaginary components are captured. Units: (I, q) Value: 32 bit quantities
rx-rawburst-ant1-y2n (0x02)	Represents a snapshot of the received signal for RF resource 2. For every sample, the real and imaginary components are captured. Units: (I, q) Value: 32 bit quantities
rx-spectrumant1-y2k (0x04)	Represents a snapshot of the spectrum of the received signal for RF resources 1. For every sample, the real and imaginary components are captured. Units: (I, q) Value: 32 bit quantities
rx-spectrum-ant1-y2k (0x08)	Represents a snapshot of the spectrum of the received signal for RF resource 2. For every sample, the real and imaginary components are captured. Units: (I, q) Value: 32 bit quantities
rx-timedomainchannel-ant1-h1n (0x10)	Represents a snapshot of the time domain channel for RF resource 1. For every sample, the real and imaginary components are captured. Units: (I, q) Value: 32 bit quantities
rx-timedomainchannel-ant2-h2n (0x20)	Represents a snapshot of the time domain channel for RF resource 2. For every sample, the real and imaginary components are captured. Units: (I, q) Value: 32 bit quantities
rx-freqdomainchannel-ant1-h1k (0x40)	Represents a snapshot of the frequency domain channel for RF resource 1. For every sample, the real and imaginary components are captured. Units: (I, q) Value: 32 bit quantities

ALPHA DRAFT - CISCO CONFIDENTIAL

Configuring a Wireless Modem Card

rx-freqdomainchannel-ant2-h2k (0x80)	Represents a snapshot of the frequency domain channel for RF resource 2. For every sample, the real and imaginary components are captured. Units: (I, q) Value: 32 bit quantities
rx-constellation-zhatk (0x100)	Represents a snapshot of the soft decisions. For every sample, the real and imaginary components are captured. Units: (I, q) Value: 32 bit quantities
tx-codec-input (0x200)	Represents a snapshot of input values to the Tx Code. Units: Real values Value: 32 bit quantities
tx-iffit-input (0x400)	Represents a snapshot of the IFFT signal for the transmitted data. For every sample, the real and imaginary components are captured. Units: (I, q) Value: 32 bit quantities
tx-round-output (0x800)	Represents a snapshot of the Rounded Constellation signal for the transmitted data. For every sample, the real and imaginary components are captured. Units: (I, q) Value: 32 bit quantities
sync-burst-timecost-func (0x1000)	Represents the timing cost function for Sync bursts. Units: Real Values Value: 32 bit quantities
sync-freq-offset-costfunc (0x2000)	Represents a snapshot of the frequency offsets. For every sample, the real and imaginary components are captured. Units: (I, q) Value: 32 bit quantities
sync-pwrsbtceffocf (0x4000)	Represents a snapshot of Sync power burst. For every sample, the real and imaginary components are captured. Units: (I, q) Value: 32 bit quantities
sync-fll-freq-correlation (0x4000)	Represents a snapshot of Frequency correlation. For every sample, the real and imaginary components are captured. Units: (I, q) Value: 32 bit quantities
sync-fll-train-tone-correlation (0x10000)	Represents a snapshot of Frequency locked loops, Training tone correlation. For every sample, the real and imaginary components are captured. Units (I, q) Value: 32 bit quantities

sync-fll-fft-spectrum (0x20000)	Represents a snapshot of Frequency locked loop, FFT Spectrum. For every sample, the real and imaginary components are captured. Units: (I, q) Value: 32 bit quantities
---------------------------------	--

Example

(explanation of example here)

```
WMCS01(boot)(config-if)# radio snapshot TBD
```

scope-output

Use this command to configure a single DSP to send the identified type of output to the serial port. An oscilloscope can be connected to the serial port to analyze the output of the DSP. Privileged configuration access is required.

Use the **no** form of the command to turn off the serial output.

Use the **show interfaces radio <slot>/<port> scope-output** command to display the attribute being directed to the scope port.

radio scope-output <dspId> <outputType>

no radio scope-output <dspId>

show interfaces radio <slot>/<port> scope-output

Syntax Description

dspId	<{dsprx1a Receive DSP 1a dsprx1b Receive DSP 1b dsprx2a Receive DSP 2a dsprx2b Receive DSP 2b dsprx3a Receive DSP 3a dsprx3b Receive DSP 3b dsptx1 Transmit DSP 1 dsptx2 Transmit DSP 2}>
outputType	<{rx-rawburst-ant1-y1n rx-rawburst-ant1-y2n rx-spectrum-ant1-y1k rx-spectrum-ant1-y2k rx-timedomainchannel-ant1-h1n rx-timedomainchannel-ant2-h2n rx-freqdomainchannel-ant1-h1k rx-freqdomainchannel-ant2-h2k rx-constellation-zhatak tx-codec-input tx-iffit-input tx-round-output sync-burst-timecost-func sync-freq-offset-costfunc sync-pwrsbtcfocf sync-fll-freq-corelation sync-fll-train-tone-corelation sync-fll-fft-spectrum}>
slot	Positive integer representing the Cisco uBR7200 series slot number.
port	Positive integer representing the port number on that slot.

Example

The following command configures DSP dsprx1a to send output of type rx-timedomainchannel-ant2-h2n to the serial port.

```
WMCS01(boot)(config-if)# radio scope-output dsprx1a RxTimeDomainChannelant2H2n
```

Using the Debug Commands

The following commands are available to troubleshoot the (system). To use any of these commands, privileged configuration access is required.

Use the command **debug radio?** to display a list of all available debug commands.

Use the **no** version of the command to stop the process.

Use the **show debug** command to display the current debug settings.

debug radio <{**lm_log** | **messages** | **phy**}>

no debug radio

show debug

Syntax Description

<code>lm_log</code>	<code>log [verbose]</code>
<code>phy</code>	<{radioLog cwrLog}>
<code>radioLog</code>	<code>radio <slot>/<port> <subModule></code>
<code>slot</code>	Positive integer representing the Cisco uBR7200 series slot number.
<code>port</code>	Positive integer representing the port number on that slot.
<code>subModule</code>	<{cli gal snmp}> <logLevel>
<code>cli</code>	Tracing for radio interface CLI commands.
<code>gal</code>	Tracing for the GAL module.
<code>snmp</code>	Tracing for the radio SNMP module.
<code>logLevel</code>	<{all controlFlow dataFlow validation verbose}>
<code>cwrLog</code>	<code>cwrLog <modName></code>
<code>modname</code>	Name of the module

Debug commands are divided into four general categories: Link Manager Logging, Link Management Messages, Physical Layer, and Radio Interface Specific Logging. Each of these is described below.

Link Manager Logging

This command controls the debugging of the Link Manager and Baseline Privacy Interface.

```
WMCS01(boot)(config-if)# debug radio log [verbose]
```

When this command is enabled, the following events can be reported.

```
CWRP2P_LOG_BPKM_INVALID_CODE_IN_BPKM_MSG
```

```
CWRP2P_LOG_BPKM_REPLY_MSG_RCVD
```

```
CWRP2P_LOG_BPKM_REQUEST_MSG_RCVD
```

```
CWRP2P_LOG_BPKM_REPLY_MSG_SENT
```

CWRP2P_LOG_BPKM_REQUEST_MSG_SENT
CWRP2P_LOG_DRIER_RESET
CWRP2P_LOG_STATE_CHANGE
CWRP2P_LOG_UNKNOWN_TIMER
CWRP2P_LOG_WATCHDOG_TIMER
CWRP2P_LOG_PRIVACY_TIMER
CWRP2P_LOG_PRIVACY_ERROR_CODE
CWRP2P_LOG_ENCRYPTION_NOT_ENABLED
CWRP2P_LOG_ENCRYPTION_IS_NOT_AVAILABLE
CWRP2P_LOG_PRIVACY_ESTABLISHED
CWRP2P_LOG_PRIVACY_SYNC_LOST
CWRP2P_LOG_PRIVACY_CANT_GEN_RSA_KEYS
CWRP2P_LOG_PRIVACY_CANT_DECRYPT_AUTH_KEY
CWRP2P_LOG_PRIVACY_CANT_ENCRYPT_AUTH_KEY
CWRP2P_LOG_RADIO_PHY_UP
CWRP2P_LOG_RADIO_PHY_DOWN
CWRP2P_LOG_RADIO_PHY_SYNC_LOST
CWRP2P_LOG_UNKNOWN_RADIO_PHY_LM_MSG_ID
CWRP2P_LOG_UNKNOWN_QUEUE_EVENT
CWRP2P_LOG_UNKNOWN_BOOLEAN_EVENT
CWRP2P_LOG_UNKNOWN_SCHEDULER_EVENT
CWRP2P_LOG_BAD_LM_MSG_LENGTH
CWRP2P_LOG_UNKNOWN_MSG_RCVD
CWRP2P_LOG_UNEXPECTED_MSG_RCVD
CWRP2P_LOG_PRIVACY_PROCESS_ALREADY_RUNNING
CWRP2P_LOG_CANT_START_PRIVACY_PROCESS
CWRP2P_LOG_BPKM_COPY_FAILED
CWRP2P_LOG_NO_MEMORY
CWRP2P_LOG_PRIVACY_UNKNOWN_RX_QUEUE_EVENT
CWRP2P_LOG_PRIVACY_UNKNOWN_BOOLEAN_EVENT
CWRP2P_LOG_PRIVACY_UNKNOWN_MAJOR_EVENT
CWRP2P_LOG_PRIVACY_PROCESS_EXITING
CWRP2P_LOG_PRIVACY_BAD_PACKET_LENGTH
CWRP2P_LOG_PRIVACY_BAD_MSG_ID
CWRP2P_LOG_PRIVACY_BAD_MESSAGE_CODE
CWRP2P_LOG_PRIVACY_KEY_SEQUENCE ERROR

CWRP2P_LOG_PRIVACY_REAUTH_REQUEST
CWRP2P_LOG_PRIVACY_FSM_BAD_STATE_EVENT
CWRP2P_LOG_PRIVACY_FSM_NO_TRANSITION
CWRP2P_LOG_PRIVACY_KEK_FSM_EVENT
CWRP2P_LOG_PRIVACY_KEK_FSM_STATE
CWRP2P_LOG_PRIVACY_TEK_FSM_EVENT
CWRP2P_LOG_PRIVACY_TEK_FSM_STATE
CWRP2P_LOG_PRIVACY_MESSAGE_FAILED_VERIFICATION
CWRP2P_LOG_PRIVACY_BAD_ATTRIBUTE_LENGTH
CWRP2P_LOG_PRIVACY_UNABLE_TO_GET_PAK_BUFFER
CWRP2P_LOG_PRIVACY_UNEXPECTED_ATTRIBUTE
CWRP2P_LOG_PRIVACY_INSTALLED_KEY
CWRP2P_LOG_PRIVACY_REMOVED_KEY
CWRP2P_LOG_PRIVACY_INVALIDATED_KEYS
CWRP2P_LOG_DRIVER_IDB_RESET
CWRP2P_LOG_UNKNOWN_TIMER_EVENT
CWRP2P_LOG_RESET_PRIVACY_WATCHDOG_DRIVER
CWRP2P_LOG_RESET_NO_MEMORY
CWRP2P_LOG_RESET_CANT_START_PROCESS
CWRP2P_LOG_RESET_FROM_DRIVER
CWRP2P_LOG_RESET_OPERATIONAL_WATCHDOG_DRIVER
CWRP2P_LOG_SEND_RADIO_UP_COMMAND_FAILED
CWRP2P_LOG_SEND_RADIO_DOWN_COMMAND_FAILED
CWRP2P_LOG_SEND_RADIO_UP_NOTIFY_FAILED
CWRP2P_LOG_SEND_RADIO_DOWN_NOTIFY_FAILED
CWRP2P_LOG_CANT_FIND_RADIO_PHY_QUEUE
CWRP2P_LOG_CANT_FIND_CARD_STRUCT

Link management Messages

This command causes the contents of the Link Management and BPI messages to be dumped in a formatted fashion as they are transmitted or received.

Note The meanings of these fields are documented in the MCNS DOCSIS standards.

```
WMCS01(boot)(config-if)# debug radio messages
```

Following is an example of the results.

```
00:01:35: Message type (0x0C): BPKM-REQ msgLEN: 133
```

```

00:01:35:      BPKM Code (0x04): Auth Request Identifier: 0x00 Length: 129
00:01:35:      Attribute Type (0x04): RSA-Public-Key Length: 126
00:01:35:      307C 300D 0609 2A86 4886 F70D 0101 0105
00:01:35:      0003 6B00 3068 0261 00B1 5407 9843 23EA
00:01:35:      74A9 3E26 07C7 686D BCA0 94ED E388 14C3
00:01:35:      B4D7 BE5E F0DA 39C1 BBC6 9A5B 6259 2F82
00:01:35:      D0A7 0704 3B61 BB61 5F10 0600 D198 3DD2
00:01:35:      9DAB 0C50 2DDA 6DDC A0F0 128E 4C00 2C6F
00:01:35:      C3FC D596 2207 20F9 C58b B777 5BDC D786
00:01:35:      E60D B8EF 7484 (B1F 7B02 0301 0001

```

Physical Layer Messages

This command causes various physical layer entities to log debug output.

```
WMCS01(boot)(config-if)# debug radio phy cwrLog <modName>
```

<modName> values are described below.

image	Modules related to image management (open, close).
download	Modules related to the download task.
chip	Modules related to chip management.
message	Modules related to cwrMessage ??
task	Modules related to the internal cwrTask management layer.
test	??
state	Modules related to generic state machine?
file	Modules related to the internal cwrFile layer.
card	Modules related to the card object as a whole.
subsystem	Modules related to subsystems, such as dsp, fir, arq.
repository	Modules related to the image repository
symbol	Logging related to symbols generated from an image.
decompressor	Logging related to the cwrDecompressor layer used by the cwrImage layer.
download_fsm	Logging for the download state machine.
matlab	Logging for the matlab task.
queue	Logging for the cwrQueue layer.
dspmsgdown	Tracing for messages sent down to the DSPs from the host.

Reference Information

dspmsgup	Tracing for messages sent up to the host from the DSPs.
subsystem	Subsystem messages or problems.
subsystem_detail	Verbose debugging information from the subsystems
memspace	Memory space driver messages or problems.

Radio Interface Specific Logging

This command provides facilities to control interface-specific logging for other entities related to the radio interface.

```
WMCS01(boot)(config-if)# debug radio phy radio 3/0 snmp verbose
```

Various logLevels determine what and how much debug log output is generated.

Reference Information

See the Cisco IOS software configuration guide and command reference publications for more advanced configuration topics. These publications are available on the documentation CD that came with your router, on the World Wide Web from Cisco's home page, or you can order printed copies.

Cisco Connection Online

Cisco Connection Online (CCO) is Cisco Systems' primary, real-time support channel. Maintenance customers and partners can self-register on CCO to obtain additional information and services.

Available 24 hours a day, 7 days a week, CCO provides a wealth of standard and value-added services to Cisco's customers and business partners. CCO services include product information, product documentation, software updates, release notes, technical tips, the Bug Navigator, configuration notes, brochures, descriptions of service offerings, and download access to public and authorized files.

CCO serves a wide variety of users through two interfaces that are updated and enhanced simultaneously: a character-based version and a multimedia version that resides on the World Wide Web (WWW). The character-based CCO supports Zmodem, Kermit, Xmodem, FTP, and Internet e-mail, and it is excellent for quick access to information over lower bandwidths. The WWW version of CCO provides richly formatted documents with photographs, figures, graphics, and video, as well as hyperlinks to related information.

You can access CCO in the following ways:

- WWW: <http://www.cisco.com>
- WWW: <http://www-europe.cisco.com>
- WWW: <http://www-china.cisco.com>
- Telnet: cco.cisco.com
- Modem: From North America, 408 526-8070; from Europe, 33 1 64 46 40 82. Use the following terminal settings: VT100 emulation; databits: 8; parity: none; stop bits: 1; and connection rates up to 28.8 kbps.

For a copy of CCO's Frequently Asked Questions (FAQ), contact cco-help@cisco.com. For additional information, contact cco-team@cisco.com.

Note If you are a network administrator and need personal technical assistance with a Cisco product that is under warranty or covered by a maintenance contract, contact Cisco's Technical Assistance Center (TAC) at 800 553-2447, 408 526-7209, or tac@cisco.com. To obtain general information about Cisco Systems, Cisco products, or upgrades, contact 800 553-6387, 408 526-7208, or cs-rep@cisco.com.

This document is to be used in conjunction with the *Cisco uBR7200 Series Universal Broadband Router Installation and Configuration Guide*, and the *Regulatory Compliance and Safety Information for the Cisco uBR7200 Series Universal Broadband Router* publications.

Access Registrar, AccessPath, Any to Any, AtmDirector, CCDA, CCDE, CCDP, CCIE, CCNA, CCNP, CCSI, CD-PAC, the Cisco logo, Cisco Certified Internetwork Expert logo, *CiscoLink*, the Cisco Management Connection logo, the Cisco NetWorks logo, the Cisco Powered Network logo, Cisco Systems Capital, the Cisco Systems Capital logo, Cisco Systems Networking Academy, the Cisco Technologies logo, ControlStream, Fast Step, FireRunner, GigaStack, IGX, JumpStart, Kernel Proxy, MGX, Natural Network Viewer, NetSonar, Network Registrar, *Packet*, PIX, Point and Click Internetworking, Policy Builder, Precept, RouteStream, Secure Script, ServiceWay, SlideCast, SMARTnet, StreamView, *The Cell*, TrafficDirector, TransPath, ViewRunner, VirtualStream, VisionWay, VlanDirector, Workgroup Director, and Workgroup Stack are trademarks; Changing the Way We Work, Live, Play, and Learn, Empowering the Internet Generation, The Internet Economy, and The New Internet Economy are service marks; and Asist, BPX, Catalyst, Cisco, Cisco IOS, the Cisco IOS logo, Cisco Systems, the Cisco Systems logo, the Cisco Systems Cisco Press logo, Enterprise/Solver, EtherChannel, EtherSwitch, FastHub, FastLink, FastPAD, FastSwitch, IOS, IP/TV, IPX, LightStream, LightSwitch, MICA, NetRanger, Registrar, StrataView Plus, Stratm, Telerouter, and VCO are registered trademarks of Cisco Systems, Inc. in the U.S. and certain other countries. All other trademarks mentioned in this document are the property of their respective owners. (9903b R)

Copyright © 1999, Cisco Systems, Inc.
All rights reserved.

