

Technical Information

Radar sensorUSR30

Free space radar

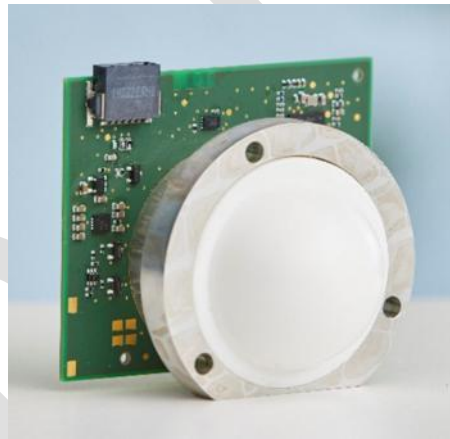

Sensor unit for distance measurement and level monitoring of liquids and bulk solids

Application

- Continuous distance measurement and level monitoring of liquids and bulk solids
- Maximum measuring range: 35 m (115 ft)
- Ambient temperature: -40 to +85 C (-40 to +176 F)

Your benefits

- Reliable 80 GHz radar sensor
- Precise distance measurement due to strong focus, even in rough environments
- Can be installed in small process connections
- Easy commissioning
- Low power consumption - suitable for battery applications

Endress+Hauser 
People for Process Automation

DRAFT

Table of contents

	FCC	11
About this document		3
Document function		3
Symbols used		3
Function and system design		4
Measuring principle		4
Input.....		4
Measured variable		4
Measuring range		4
Operating frequency		5
Blocking distance		5
Sensitivity		5
Output.....		6
Output signal		6
Protocol-specific data		6
Power supply		6
Supply voltage		6
Power consumption		6
Connection of the sensor		6
Performance characteristics		7
Reference operating conditions		7
Maximum measured error		7
Influence of ambient temperature		7
Installation.....		7
Beam angle.....		8
Environment.....		8
Ambient temperature		8
Storage temperature		8
Relative humidity		8
Operating altitude according to DIN EN 61010-1 Ed. 3		8
Degree of protection		8
Safety notes		8
Prozess.....		9
Mechanical construction		9
Dimensions		9
Weight		9
Materials.....		9
Integration into an overall system		10
Integration		10
Certificates and approvals		10
CE mark		10
RoHS		10
EN 302729-1/2 radio standard		10

Industry Canada 11
Other standards and guidelines 12

Supplementary documentation 12
Disposal 12
Contact addresses 12

Explanations and supplementary documentation . . 12

DRAFT

About this document

Document function





This document contains all the technical data for the device and provides an overview of the device versions that can be ordered.

Symbols used

Safety symbols

Symbol	Meaning
	NOTICE! This symbol contains information on procedures and other facts which do not result in personal injury.

Symbols for certain types of information

Symbol	Meaning
	Tip Indicates additional information.
	Permitted or recommended
	Forbidden or not recommended
1. 2. 3. ...	Series of steps
	Reference to page

Symbols in graphics

Symbol	Meaning
1, 2, 3, ...	Item numbers
A, B, C, ...	Views

DRAFT

Function and system design

Measuring principle

The Micropilot is a measuring system, operating based on the time-of-flight method (ToF). It measures the distance from the reference point to the product surface. The radar signals based on the "Frequency Modulated Continuous Wave" (FMCW) principle are emitted by an antenna, reflected off the product surface and received again by the radar system.

Input

Measured variable

Measured process variables

- **Level / Distance:** 0 to 35 m (0 to 115 ft)

Measuring range

Maximum measuring range: 0 to 30 m (0 to 98 ft) for solids and liquids with permittivity > 1.9

Increased measuring range: 30 to 35 m (98 to 115 ft) for solids and liquids with the following application conditions:

- Only for media with a high permittivity value, such as water.
- No turbulent surfaces
- No increased inhomogeneous atmosphere (increased amount of dust particles, gas phases, high humidity or similar)

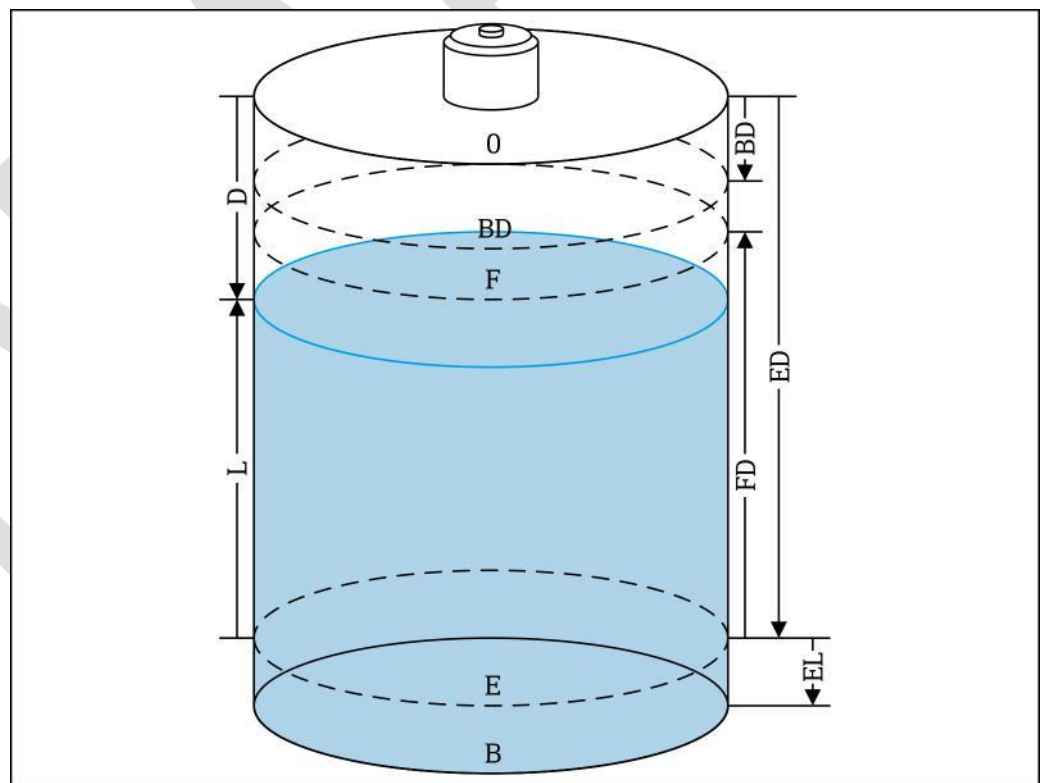

Radarsensor_Abgleichparameter

Calibration parameter

B	Ground
D	Measured distance
E	Empty calibration (= zero)
F	Full calibration (= span)
L	Level in %
BD	Blocking distance
FD	Full distance
ED	Empty distance
EL	Extended length

DRAFT

Medium

Media: solids and liquids

Usable measuring range for solid applications



The usable measuring range depends on the reflection properties of the medium, the installation position and possible interference reflections.

Measurement of the following media with absorbing gas phase

For example the following media

- Ammonia (pure - 100 %)
- Acetone
- Methylene chloride
- Methyl ethyl ketone
- Propylene oxide
- VCM (vinyl chloride monomer)

To measure absorbing gases, either use a guided radar, measuring devices with another measuring frequency or another measuring principle.

If measurements must be performed in one of these media, please contact Endress+Hauser.

Operating frequency

80 GHz

The operating frequency is for measurement purposes only.

Blocking distance

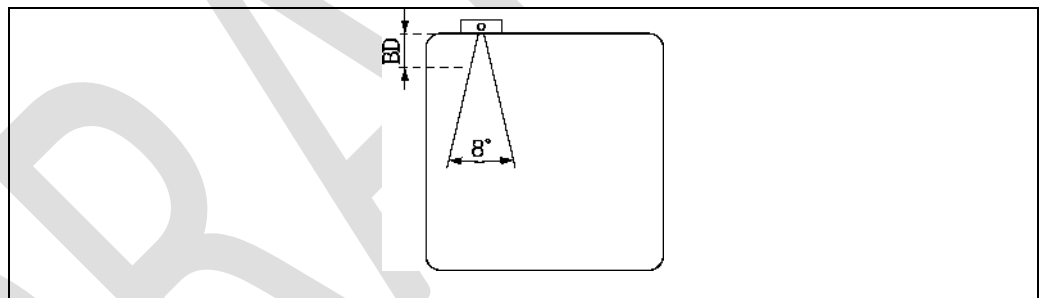

A0091499

- No signals are analyzed within the blocking distance (BD)
For this reason, the blocking distance can be used to suppress interference signals (e.g. from condensate) near the antenna.
- Factory setting: automatic
- The blocking distance (BD) can be set. The set default value is 0 mm.
The setting is made in the blocking distance parameter.

Sensitivity

The sensitivity of the sensor can be configured using a "sensitivity parameter" (high, medium, low).

DRAFT

Output

Output signal

Digital: UART (8N1 inverted)
 Baud rate: 230.4 kBd
 data bits: 8
 Parity: keine
 Stop bits: 1
 Polarity: inverted (idle low)

Protocol-specific data

The USR30 has the following read and write parameters:

Parameter	Unit	Read	Write
Measured distance	mm	X	
Measured level	%	X	
Configurable blocking distance	mm	X	X
Definition for state "Empty"	mm	X	X
Definition for level "Full"	mm	X	X
Medium type liquid / bulk solids		X	X
Trigger measurement on / off		X	X
Reception strength of radar signal	strong, medium, weak, no signal	X	
Sensitivity of sensor	low, medium, high	X	X
Hardware version		X	
Software version		X	
Serial number		X	
Error status		X	
Z-Offset	mm	X	X

Power supply

Supply voltage

The radar system requires 2 supply voltages:
 Sensor: 3.2 to 5.5 VDC
 Digital interface: 1.7 to 3.6 VDC

Power consumption

~32 mW static
 ~1000 mW peak for < 10 ms during measurement

Connection of the sensor

The connection of the sensor is described in the documentation "USR30 Customer Manual" (see Supplementary documentation □ ä 12)

DRAFT

Performance characteristics

Reference operating conditions

- Temperature = +24 C (+75 F) \pm 5 C (\pm 9 F)
- Pressure = 960 mbar abs. (14 psi) \pm 100 mbar (\pm 1.45 psi)
- Humidity = 60 % \pm 5 %
- Reflector: metal plate with a diameter \geq 1 m (40 in)
- No major interference reflections inside the signal beam

- Maximum measured error**
- Accuracy for liquids applications: \pm 2 mm (\pm 0.08 in) within the entire measuring range
 - Accuracy for bulk solids applications: \pm 10 mm (\pm 0.39 in) within the entire measuring range (higher measuring accuracy optionally possible)

The reference condition for the accuracy refers to the setting **Medium type = Liquid**.

Influence of ambient temperature

Temperature coefficient: \leq 4 mm (0.16 in) per 10 K

Installation

Mounting instructions

- Mount the end measuring device in a horizontal position so that it is parallel to the tank ceiling. Otherwise, undesired reflections from the surroundings can cause interference signals.
- The radar antenna should never be covered by metal objects
- Do not mount any objects which may cause interference, such as tank internal fittings, grids or agitators, below or in the direct vicinity of the radar (see the graphic below)

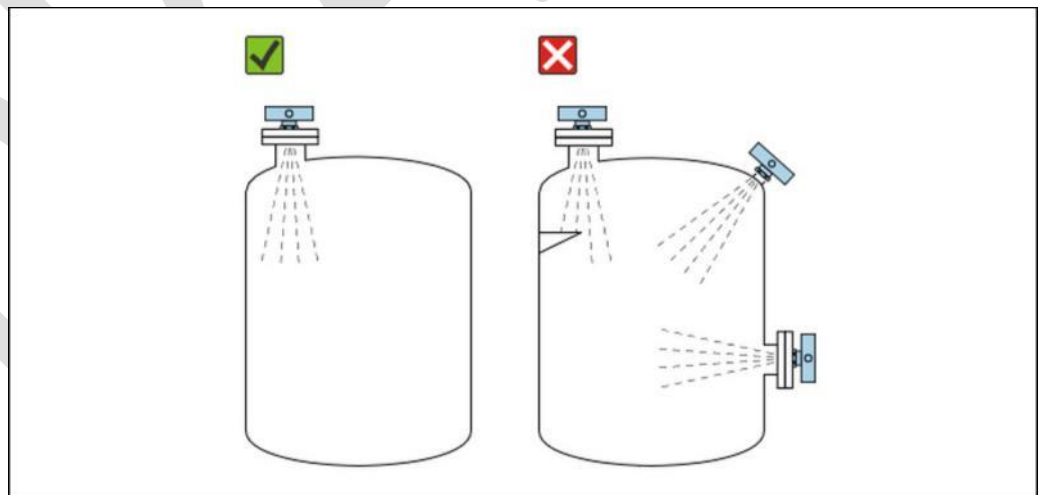

Maximum nozzle height and distance to wall _____

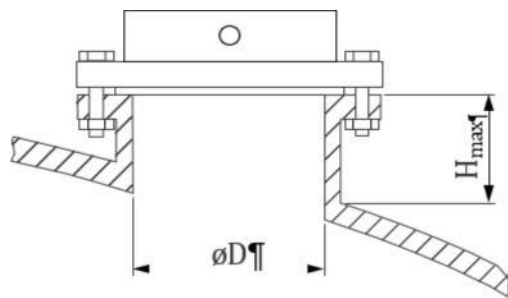

A0046856

Diameter D [mm]	H _{max} [mm]	Measuring distance [mm]	Radiation width ¹⁾ [mm]
40	230	500	70
50	300	1000	140
80	520	2000	280
100	660	5000	699
150	1020	10000	1399

1) The beam angle is 8°

Beam angle 8°

Environment

Ambient temperature -40 to +85 C (-40 to 185 F)

Storage temperature -40 to +85 C (-40 to +185 F)

Relative humidity 0 to 95 %

Operating altitude according to DIN EN 61010-1 Ed. 3 Up to 2000 m (6600 ft) above sea level

Degree of protection Open system: IP00

Safety notes For work on and with the device:

NOTICE

Danger of damaging the device

Static sensitive devices.

- ▶ Handle only at static safe work stations!



DRAFT

Process

- Measurement directly through the tank only possible for electrically non-conductive tank walls with low dielectric constant and small wall thickness
 No contact is made with the process medium.

Mechanical construction

Dimensions

Sensor unit

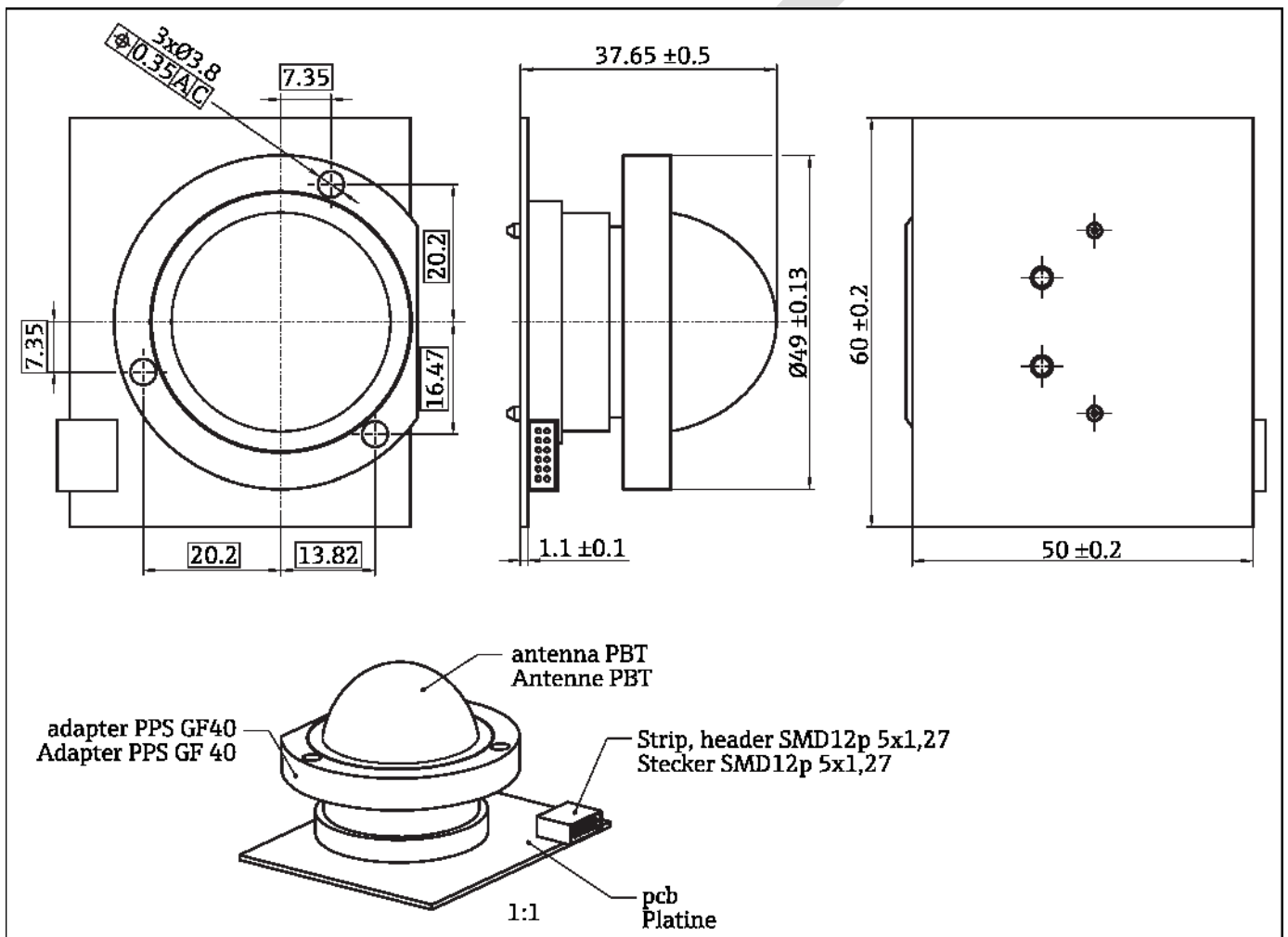

* Unit of measurement mm

NOTICE

The recommended geometry of the antenna aperture to limit the radiation angle to 8° is described in the installation instructions.

Weight

Sensor unit with antenna 68 g

Materials

- Radar antenna: Plastic PBT
- Coupling adapter: PPS GF40 (metallized)

Integration into an overall system

 It is not allowed to modify the sensor module in any way or form. The sensor must be used with the antenna provided.

Characteristics

- Simple mechanical/electrical integration into an end device
- Configuration and control via widely used digital interface (UART) with defined command set (see Customer Manual)
- Startup time: <250 ms until first measurement can be performed
- Measurement cycle time: <100 ms

Integration

- The sensor must be installed inside a closed housing.
- A minimum distance of >2mm to any mechanical part has to be left around and above the PCB as to not interfere with any signals of the sensor.
- The signal cone must not be obstructed by any elements of the housing or add ons.
- The electrical connection must be done through the provided connector (see Customer Manual for pin description). A fitting counterpart connector with a locking mechanism must be used.
- After mounting in a housing, a functional check and zero offset calibration has to be performed. The zero plane can be defined by the customer.

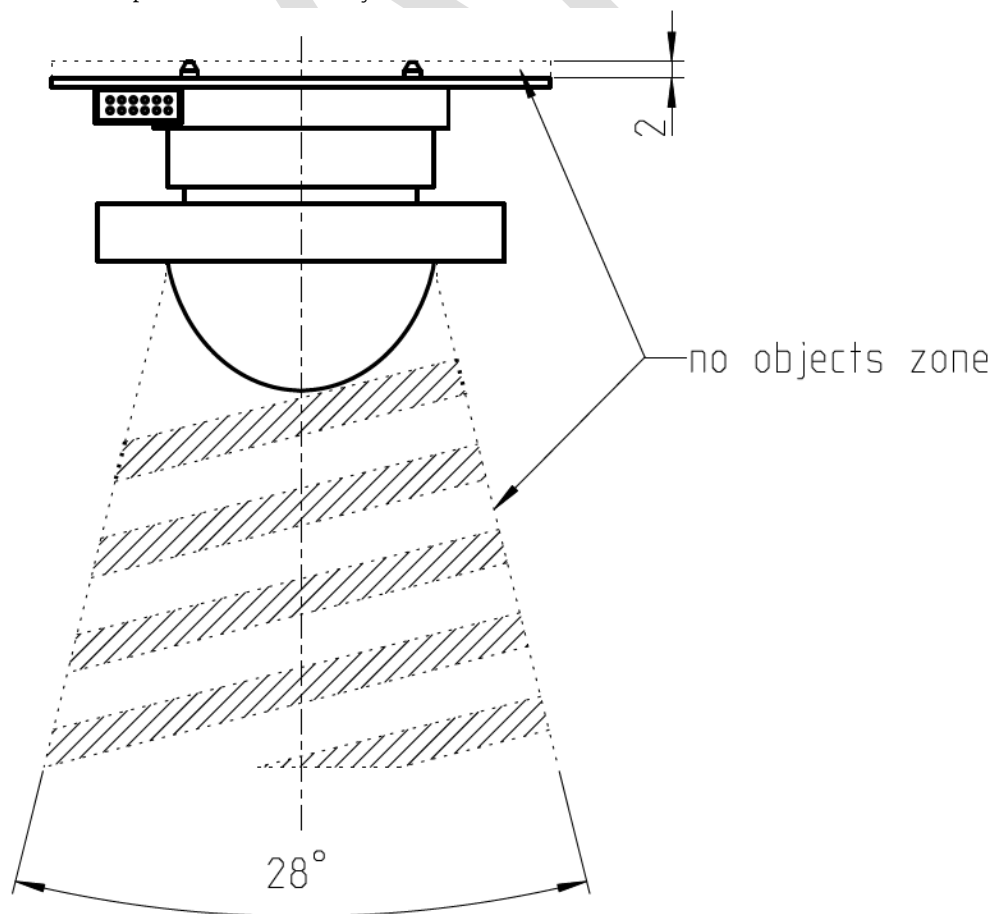

Check list

- Is the sensor undamaged (visual inspection)?
- Is the sensor properly mounted and fixed in position?
- Is the antenna and housing properly sealed?
- Is the sensor signal cone unobstructed?
- Is the electrical connector properly fitted and locked?
- Is the sensor responsive and returns a correct measurement value without any communication errors or active error bits?

DRAFT

Certificates and approvals

NOTICE

The USR30 radar sensor is a sensor unit that is installed as a component in the customer's end system. It is therefore the customer's responsibility to obtain the relevant approvals for his end device / measuring system.

Endress+Hauser's closed measuring systems that include this sensor unit comply with the following guidelines:

CE mark

The **closed-loop measuring systems** from Endress+Hauser **with this sensor unit** meet the legal requirements of the applicable EU directives. These are listed in the corresponding EU Declaration of Conformity together with the standards applied.

RoHS

The Directive on the Restriction of the Use of Certain Hazardous Substances 2011/65/EU (RoHS 2) and the Delegated Directive (EU) 2015/863 (RoHS 3).

EN 302729-1/2 radio standard

LPR (Level Probing Radar) radio standard EN 302729 for unrestricted use inside and outside of closed vessels in countries of the EU and EFTA.

As a prerequisite, the countries in question must have already implemented this standard.

The following countries are those that have currently implemented the standard:

Belgium, Bulgaria, Germany, Denmark, Estonia, France, Greece, UK, Ireland, Iceland, Italy, Liechtenstein, Lithuania, Latvia, Malta, The Netherlands, Norway, Austria, Poland, Portugal, Romania, Sweden, Switzerland, Slovakia, Spain, Czech Republic and Cyprus.

Implementation is still underway in all of the countries not listed.

Please note the following for operation of the devices outside of closed vessels:

1. The device must be mounted in accordance with the instructions in the "Installation" section.
2. Installation must be carried out by properly trained, expert staff.
3. The device antenna must be installed in a fixed location pointing vertically downwards.
4. The installation site must be located at a distance of 4 km from the astronomy stations listed below or otherwise approval must be provided by the relevant authority. If the device is installed at a distance of 4 to 40 km from one of the listed stations, it must not be installed at a height of more than 15 m (49 ft) above the ground.

Astronomy stations

Country	Name of the station	Latitude	Longitude
Germany	Effelsberg	50°31'32" North	06°53'00" East
Finland	Metsähovi	60°13'04" North	24°23'37" East
	Tuorla	60°24'56" North	24°26'31" East
France	Plateau de Bure	44°38'01" North	05°54'26" East
	Floirac	44°50'10" North	00°31'37" West

Country	Name of the station	Latitude	Longitude
Great Britain	Cambridge	52°09'59" North	00°02'20" East
	Damhall	53°09'22" North	02°32'03" West
	Jodrell Bank	53°14'10" North	02°18'26" West
	Knockin	52°47'24" North	02°59'45" West
	Pickmere	53°17'18" North	02°26'38" West
Italy	Medicina	44°31'14" North	11°38'49" East
	Noto	36°52'34" North	14°59'21" East
	Sardinia	39°29'50" North	09°14'40" East
Poland	Krakow Fort Skala	50°03'18" North	19°49'36" East
Russia	Dmitrov	56°26'00" North	37°27'00" East
	Kalyazin	57°13'22" North	37°54'01" East
	Pushchino	54°49'00" North	37°40'00" East
	Zelenchukskaya	43°49'53" North	41°35'32" East
Sweden	Onsala	57°23'45" North	11°55'35" East
Switzerland	Bleien	47°20'26" North	08°06'44" East
Spain	Yebes	40°31'27" North	03°05'22" West
	Robledo	40°25'38" North	04°14'57" West
Hungary	Penc	47°47'22" North	19°16'53" East



As a general rule, the requirements outlined in EN 302729-1/2 must be observed.

FCC

§ 15.19 Labeling requirements:

This device complies with part 15 of the FCC Rules. Operation is subject to the following two conditions:

- (1) This device may not cause harmful interference, and
- (2) this device must accept any interference received, including interference that may cause undesired operation.

§ 15.21 Information to user:

Caution! Changes or modifications not expressly approved by the party responsible for compliance could void the user's authority to operate the equipment.

Industry Canada

This device contains licence-exempt transmitter(s)/receiver(s) that comply with Innovation, Science and Economic Development Canada's licence-exempt RSS(s). Operation is subject to the following two conditions:

1. This device may not cause interference.
2. This device must accept any interference, including interference that may cause undesired operation of the device.

L'émetteur/récepteur exempt de licence contenu dans le présent appareil est conforme aux CNR d'Innovation, Sciences et Développement économique Canada applicables aux appareils radio exempts de licence. L'exploitation est autorisée aux deux conditions suivantes:

1. L'appareil ne doit pas produire de brouillage;
2. L'appareil doit accepter tout brouillage radioélectrique subi, même si le brouillage est susceptible d'en compromettre le fonctionnement.

Compliance procedure

of host device:

The final host device, into which this modular approved transmitter is finally integrated has to comply itself to the appropriate technical requirements (typically §15.107 AC Powerline Conducted Limits, §15.109 Radiated Emission Limits for an Unintentional Radiator) and apply applicable FCC Equipment Authorization Procedures (SDoC or Certification).

The installer/user of this device shall ensure that it is at least 10 km from the Dominion Astrophysical Radio Observatory (DRAO) near Penticton, British Columbia. The coordinates of the DRAO are latitude 49°19'15" N and longitude 119°37'12" W. For devices not meeting this 10 km separation (e.g., those in the Okanagan Valley, British Columbia,) the installer/user must coordinate with, and obtain the written concurrence of, the Director of the DRAO before the equipment can be installed or operated. The Director of the DRAO may be contacted at 250-497-2300 (tel.) or 250-497-2355 (fax). (Alternatively, the Manager, Regulatory Standards Industry Canada, may be contacted.)

Host devices marketed to Canada are typically subject to ICES-003 Information Technology Equipment (including Digital Apparatus) and the SDoC procedure.

This modular approved transmitter is tested and certified as stand-alone device under FCC

§15.256 "Operation of level probing radars within the bands 5.925–7.250 GHz, 24.05–29.00 GHz, and 75–85 GHz" and ISED RSS-211 – Level Probing Radar. When the module is integrated into the final host device, the integrator has to repeat the Fundamental Field Strength and Out-of-Band Emission measurements to assure compliance with the

FCC/ISED requirements of the radar module when operating inside the host device.

If the host device contains itself a transmitter, the device has to be fully tested and certified under the applicable FCC rule part / ISED RSS-standard. In addition, simultaneous transmission compliance measurements are required to assure that the device complies with the FCC / ISED requirements having all transmitters operational (FCC Multi-transmitter Policy). This also applies when multiple certified RF Modules are integrated in addition to the level probing radar.

Labelling Requirements of Host device:

When this modular approved transmitter is integrated into a final host device, host devices marketed in the US has to be permanently labelled with "Contains FCC ID: LCGUXR3XYEL".

Furthermore, the host device has to comply with the §15.19 Labelling requirements.

For host devices marketed to Canada "Contains IC: 2519A-YEL" shall be affixed accordingly.

FCC §15.256 (a)~(e) and RSS-211 Section 6. User Manual apply to the Host Device.

The final host device with the integrated level probing radar complies with the FCC / ISED RF exposure requirements for an uncontrolled environment, when fixed installed by trained installers.

DRAFT

Other standards and guidelines

EN 61010-1

Explanations and supplementary documentation

Supplementary documentation



For an overview of the scope of the associated Technical Documentation, refer to the following:

- USR30 Customer manual

Disposal



As required by the Directive 2012/19/EU on waste electrical and electronic equipment (WEEE), our products are marked with the depicted symbol in order to minimize the disposal of WEEE as unsorted municipal waste. Such products may not be disposed of as unsorted municipal waste and can be returned to Endress+Hauser for disposal under the conditions stipulated in the General Terms and Conditions or as individually agreed.

Contact addresses

Internet: www.sensors-components.endress.com
E-mail: sensors-components.ehlp@endress.com

DRAFT

DRAFT

DRAFT

DRAFT

DRAFT

DRAFT

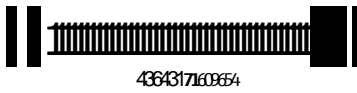

4364317160964

DRAFT