

Technical Information

Micropilot NMR84

Tank Gauging



Application

Micropilot NMR8 Series intelligent tank gauges are designed for high accuracy liquid level measurement in storage and process applications. They fulfill the exacting demands of tank inventory management, inventory control, custody transfer, loss control, total cost saving, and safe operation.

Typical areas of application

- Precise level measurement of oil (fuels), chemicals, and alcohol in stilling wells
- Tank mounted intelligence makes NMR8x ideal for single or multi-task installations, measuring the liquid level and integrating a wide range of tank sensor measurement functions including: Liquid level, Water level, Temperature and Pressure.

Your benefits

- SIL2/3 Certified (Min, Max, Continuous Level) (in preparation)
- Up to 6 SIL relay outputs
- Measures liquid level to an accuracy of +/- 0.5 mm ($\frac{1}{32}$ in)
- Wetted parts are completely separated from the electronic circuit
- Tank top mounting as small as 4"/DN100 flange
- Wide range of output signals including V1, Modbus RS 485, and HART protocol
- Suitable for atmospheric and high pressure applications up to 25 bar/2.5 MPa/ 362 psi
- Maintenance prediction of the instrument
- Integration of e.g. temperature, water level, pressure, overflow prevention sensor
- Direct connection of spot or average temperature sensor
- Robust IP66/68, NEMA Type 4x/6P enclosure
- Operation and display in a wide variety of local languages





Table of contents

Document information	3	Process	18
Symbols	3	Process temperature range	18
Function and system design	5	Process pressure range	18
Measuring principle	5	Dielectric constant	18
Integration of tank sensors	6	Custody transfer approval	19
Measuring system	7	Mechanical construction	20
Input	8	Dimensions	20
Measured variable	8	Weight	24
Maximum measuring range	8	Materials	25
Operating frequency	8	Operability	28
Transmitting power	8	Operating concept	28
HART Ex ia/IS active input	8	Operating options	28
Output	9	Local operation	28
I/O modules	9	Remote operation	29
"Modbus RS485": Technical data	10	Operation via service interface	29
"V1": Technical data	11	Certificates and approvals	30
"4-20mA HART" I/O module (Ex d/XP or Ex i/IS): Technical data	11	CE mark	30
"Digital I/O module": Technical data	11	RCM-Tick marking	30
Power supply	12	Ex approval	30
Terminal assignment	12	Dual seal according to ANSI/ISA 12.27.01	30
Supply voltage	12	Functional Safety (SIL)	30
Cable entries	13	WHG	30
Cable specification	13	Weight & Measure approval	30
Overvoltage protection	13	Radio standard EN302372-1/2	30
Performance characteristics	14	FCC / Industry Canada	30
Reference operating conditions	14	Non-ionizing radiation protection	31
Measured value resolution	14	Test, certificate	31
Maximum measured error	14	Other standards and guidelines	31
Hysteresis	14	Ordering information	33
Repeatability	14	Ordering information	33
Linearity	14	Calibration certificate	33
Long-term drift	14	Customized parametrization	34
Influence of ambient temperature	14	Marking	34
Installation	15	Application packages	35
Installation conditions	15	Advanced tank measurement methods	35
Environment	16	Accessories	38
Ambient temperature range	16	Device-specific accessories	38
Ambient temperature limits	16	Communication-specific accessories	39
Classification of environmental conditions according to DIN EN 60721-3-4	17	Service-specific accessories	39
Storage temperature	17	System components	39
Humidity	17	Documentation	40
Degree of protection	17	Technical Information (TI)	40
Shock resistance	17	Brief Operating Instructions (KA)	40
Vibration resistance	17	Operating Instructions (BA)	40
Electromagnetic compatibility (EMC)	17	Description of Device Parameters (GP)	40
		Safety instructions (XA)	40
		Registered trademarks	41







Document information

Symbols









Safety symbols

Symbol	Meaning
	DANGER! This symbol alerts you to a dangerous situation. Failure to avoid this situation will result in serious or fatal injury.
	WARNING! This symbol alerts you to a dangerous situation. Failure to avoid this situation can result in serious or fatal injury.
	CAUTION! This symbol alerts you to a dangerous situation. Failure to avoid this situation can result in minor or medium injury.
	NOTE! This symbol contains information on procedures and other facts which do not result in personal injury.



Electrical symbols

Symbol	Meaning	Symbol	Meaning
	Direct current		Alternating current
	Direct current and alternating current		Ground connection A grounded terminal which, as far as the operator is concerned, is grounded via a grounding system.
	Protective ground connection A terminal which must be connected to ground prior to establishing any other connections.		Equipotential connection A connection that has to be connected to the plant grounding system: This may be a potential equalization line or a star grounding system depending on national or company codes of practice.

Symbols for certain types of information

Symbol	Meaning
	Permitted Procedures, processes or actions that are permitted.
	Preferred Procedures, processes or actions that are preferred.
	Forbidden Procedures, processes or actions that are forbidden.
	Tip Indicates additional information.
	Reference to documentation
	Reference to page
	Reference to graphic
	Visual inspection

Symbols in graphics

Symbol	Meaning
1, 2, 3 ...	Item numbers
1., 2., 3. ...	Series of steps
A, B, C, ...	Views
A-A, B-B, C-C, ...	Sections
	Hazardous area Indicates a hazardous area.
	Safe area (non-hazardous area) Indicates the non-hazardous area.

Function and system design

Measuring principle

Micropilot is a directional level radar, operating based on the "Frequency-Modulated Continuous Wave" principle (FMCW). The radar emits a precise crystal-oscillated, continuously varying frequency wave from the antenna. The wave is reflected off the product surface and received again by the radar system.

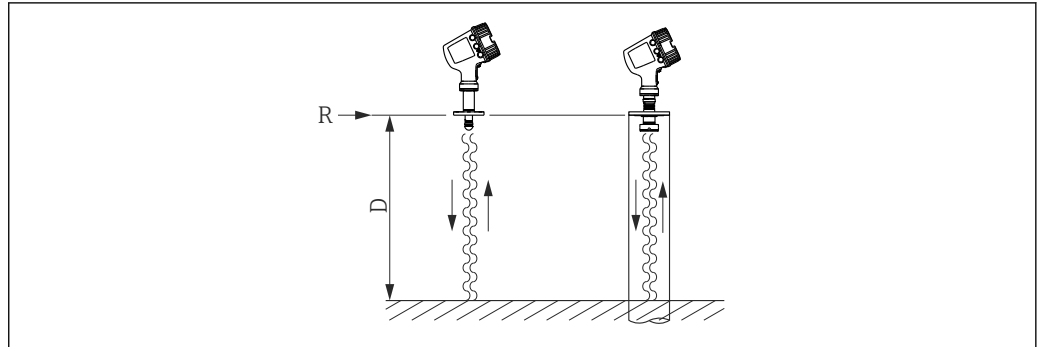

A0023768

1 FMCW principle: Emission and reflection of the continuous wave.

R Reference point of the measurement

D Distance between R and the product surface

The frequency of this wave is precisely modulated in the form of a sawtooth signal between two limit frequencies f_1 and f_2 :

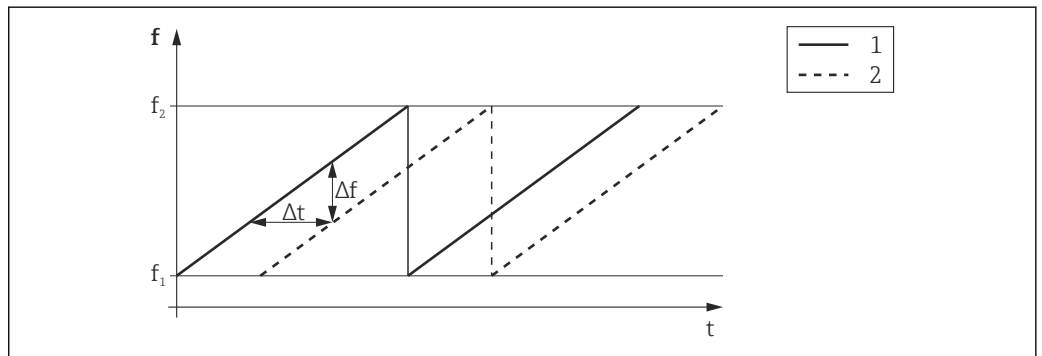

A0023771

2 FMCW principle: Results of the frequency modulation

1 Emitted signal

2 Received signal

Thus, at any given time the frequencies of the emitted and the received signal differ by

$$\Delta f = k \Delta t$$

where Δt is the transit time and k is the known slope of the frequency modulation.

Δt , on the other hand, is determined by the distance D between the reference point R and the product surface:

$$D = (c \Delta t) / 2$$

where c is the speed of propagation of the wave.

In summary, D can be calculated from the measured frequency shift Δf . D is then used to calculate the contents of the tank.

Integration of tank sensors

In addition to measuring the level, the device can also be used for the integration of tank sensors into tank inventory systems. All measured and calculated values can be displayed at the built-in display. Via a field communication protocol, they can be transferred to an inventory control system.

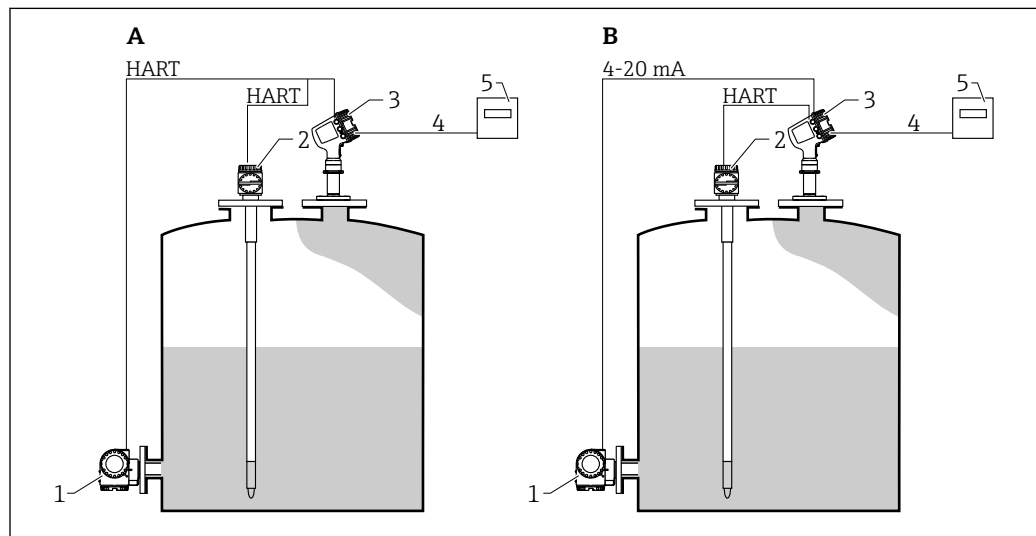

A0023767

3 Integration of tank sensors with Micropilot (Example)

A HART multidrop mode

B HART and analog mode

1 Pressure transmitter

2 Average temperature transmitter

3 Micropilot

4 Field protocol transmits data to an inventory control system

5 Inventory control system (e.g. Tankvision NXA820 or Tankvision Professional NXA85)

Measuring system

- From single tank level measurement to the largest oil refinery applications, Endress+Hauser tank gauging devices are an integral part of tank farm management solutions. A wide variety of data output protocols are available for seamless integration into many commonly used systems.
- A primary example is Tankvision from Endress+Hauser. Tankvision is a scalable system offering local tank management for multiple loops via Modbus or V1 protocols. Accumulated data is available to DCS and other plant management systems via a Host Link.

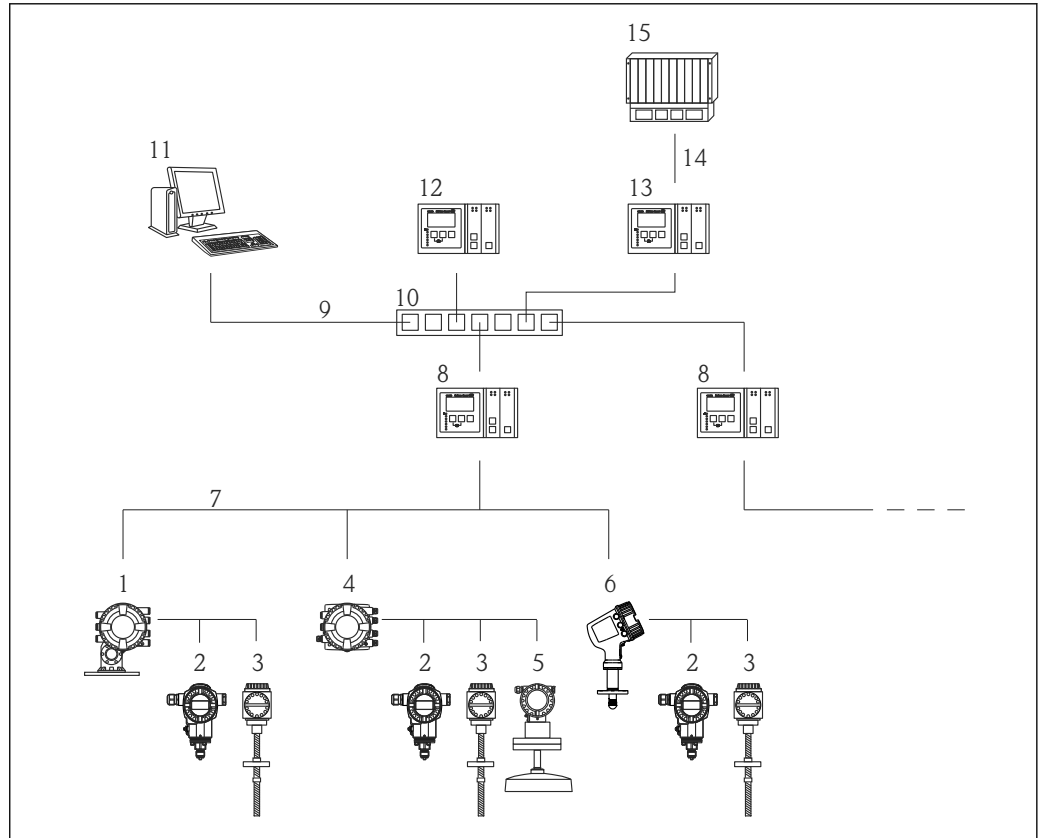

A0027700

4 Integration of tank gauging devices into an inventory management system (typical example)

- 1 Proservo NMS8x
- 2 Pressure transmitter (e.g. Cerabar)
- 3 Temperature transmitter (e.g. Prothermo)
- 4 Tankside Monitor NRF81
- 5 Micropilot S FMR5xx
- 6 Micropilot NMR8x
- 7 Field protocol (e.g. Modbus, V1)
- 8 Tankvision Tank Scanner NXA820
- 9 Ethernet
- 10 Ethernet switch
- 11 Internet Browser
- 12 Tankvision Data Concentrator NXA821
- 13 Tankvision Host Link NXA822
- 14 Modbus
- 15 DCS or PLC

Input

Measured variable The measured variable is the distance between a reference point (mounting flange) and a reflective surface (e.g. product surface).

Antenna ¹⁾	Weight+Measure approval ²⁾	Maximum measuring range
BD: Planar 100mm/4"	any	0.8 to 20 m (2.6 to 66 ft)
<ul style="list-style-type: none"> ▪ BF: Planar 150mm/6" ▪ BG: Planar 200mm/8" ▪ BH: Planar 250mm/10" ▪ BJ: Planar 300mm/12" 	w/o <ul style="list-style-type: none"> ▪ LK: NMI witnessed initial verification accuracy, Weight+Measure approval (in preparation) ▪ LL: PTB witnessed initial verification accuracy, Weight+Measure approval (in preparation) 	0.8 to 40 m (2.6 to 131 ft)
		0.8 to 30 m (2.6 to 98 ft)

1) Ordering feature 100: "Antenna"

2) Ordering feature 590: "Additional Approval"

Device	Operating frequency
NMR84	approx. 6 GHz

Device	Peak pulse power	Average output power
NMR84	1.4 mW	21 μ W

HART Ex ia/IS active input

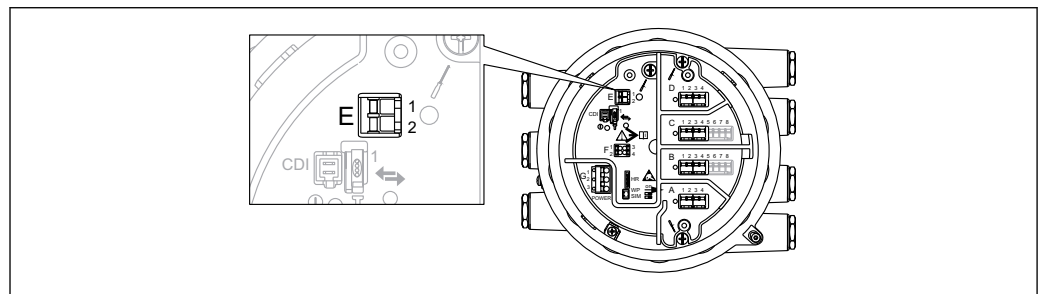

A0027364

5 HART Ex ia/IS active input

E1 HART +

E2 HART -

The device has a HART Ex ia/IS active input. Additional features are provided if the following Endress+Hauser devices are connected:

Prothermo NMT

The measured level is transmitted to the Prothermo. Prothermo uses this level to calculate the average temperature of the product.

Output

I/O modules

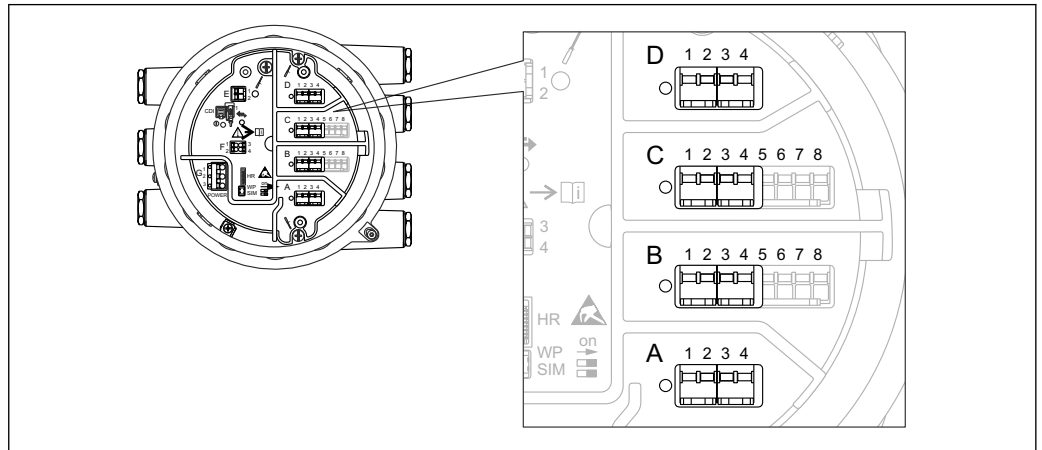

6 Position of the I/O modules in the terminal compartment

The terminal compartment contains up to four I/O modules, depending on the order code.

- Modules with four terminals can be in any of these slots.
- Modules with eight terminals can be in slot B or C.

i The exact assignment of the modules to the slots is dependent on the device version. For a detailed description refer to the Operating Instructions of the device in question.

- i** The following restrictions apply when selecting the modules:
- The device may contain a maximum of four I/O modules.
 - A maximum of two I/O modules with 8 terminals is possible.

Ordering feature 040: "Primary Output"

NMx8x - xxxx <u>XX</u> xx xx ... 040				
Option	Number of I/O modules	Type of I/O module	Number of terminals	Technical data
A1	1	Modbus RS485	4	→ 10
B1	1	V1	4	→ 11
E1	1	4-20mA HART Ex d/XP	8	→ 11
H1	1	4-20mA HART Ex i/IS	8	→ 11

Ordering feature 050: "Secondary IO Analogue"

NMx8x - xxxx xx <u>XX</u> xx ... 050				
Option	Number of I/O modules	Type of I/O module	Number of terminals	Technical data
A1	1	1 x "Ex d/XP 4-20mA HART + RTD input"	1 x 8	→ 11
A2	2	2 x "Ex d/XP 4-20mA HART + RTD input"	2 x 8	→ 11
B1	1	1 x "Ex i/IS 4-20mA HART+ RTD input"	1 x 8	→ 11
B2	2	2 x "Ex i/IS 4-20mA HART+ RTD input"	2 x 8	→ 11
C2	2	1 x "Ex i/IS 4-20mA HART + RTD input" 1 x "Ex d/XP 4-20mA HART + RTD input"	2 x 8	→ 11
X0	0	none	0	-

Ordering feature 060: "Secondary IO Digital Exd"

NMx8x - xxxx xx xx <u>XX</u> ... 060				
Option	Number of I/O modules	Type of I/O module	Number of terminals	Technical data
A1	1	1 x "2x relay + 2x discrete I/O"	1 x 4	→ 11
A2	2	2 x "2x relay + 2x discrete I/O"	2 x 4	→ 11
A3	3	3 x "2x relay + 2x discrete I/O"	3 x 4	→ 11
B1	1	1x "Modbus RS485"	1 x 4	→ 10
B2	2	1x "Modbus RS485" 1 x "2x relay + 2x discrete I/O"	2 x 4	→ 10 → 11
B3	3	1x "Modbus RS485" 2 x "2x relay + 2x discrete I/O"	3 x 4	→ 10 → 11
X0	0	none	0	-

"Modbus RS485": Technical data

No. of units	Maximum 15 instruments per loop
Baud rate	Selectable: <ul style="list-style-type: none"> ▪ 600 bit/s ▪ 1200 bit/s ▪ 2400 bit/s ▪ 4800 bit/s ▪ 9600 bit/s ▪ 19200 bit/s
Parity	Selectable: <ul style="list-style-type: none"> ▪ Odd ▪ Even ▪ None
Cable	Three-wire cable with screening. The screening must be connected inside the housing.
Termination resistors	To be set as required in specific environments
Topology	<ul style="list-style-type: none"> ▪ Serial bus ▪ Tree structure
Transmission distance	Maximum 1200 m (3900 ft) including limbs or branches; branches under 3 m (9.8 ft) are negligible
Instrument address	Each transmitter has an individual bus address configured in the software of the transmitter.
Isolation	Bus inputs are electrically isolated from the other electronics.
Error on alarm	Error message classified according to NAMUR NE 107

"V1": Technical data

No. of units	Maximum 10 instruments per loop
Baud rate	3 300 bit/s
Parity	Selectable: <ul style="list-style-type: none"> ▪ Odd ▪ Even ▪ None
Cable	<ul style="list-style-type: none"> ▪ Two-wire twisted pair; screening recommended ▪ Two-wire unshielded
Termination resistors	Not required
Topology	<ul style="list-style-type: none"> ▪ Serial bus ▪ Tree structure
Transmission distance	Maximum 6 000 m (19 700 ft)
Instrument address	Each transmitter has an individual bus address configured in the software of the transmitter.
Isolation	Serial communication circuit isolated from other circuits
Error on alarm	Error message classified according to NAMUR NE 107

**"4-20mA HART" I/O module
(Ex d/XP or Ex i/IS):
Technical data**

No. of units	Max. 6 instruments per loop
Baud rate	1 200 bit/s
Cable	Two-wire, twisted pair screened cable; Core cross section: 0.2 to 2.5 mm ² (24 to 13 AWG)
Topology	<ul style="list-style-type: none"> ▪ Serial bus ▪ Tree structure
Transmission distance	Maximum 1 200 m (3 900 ft)
Instrument address	Each transmitter on a signal loop has an individual bus address. This is defined within the transmitter software and / or auxiliary configuration environment such as host system or Field Communicator 475.
Isolation	Bus inputs are electrically isolated from the other electronics
Connection of a Prothermo NMT	The measured level is transmitted to the Prothermo. Prothermo uses this level to calculate the average temperature of the product.
Connection of a RTD temperature probe	3-wire or 4-wire connection
Error on alarm	Error message classified according to NAMUR NE 107

**"Digital I/O module":
Technical data**

Output	
Relay switching power for resistive load	<ul style="list-style-type: none"> ▪ 30 V_{DC} @ 2 A ▪ 250 V_{DC} @ 0.1 A ▪ 250 V_{AC} @ 2 A
Input	
Maximum pick-up voltage	<ul style="list-style-type: none"> ▪ 250 V_{AC} ▪ 250 V_{DC}
Minimum drop-out voltage	<ul style="list-style-type: none"> ▪ 25 V_{AC} ▪ 5 V_{DC}
Current consumption at maximum voltage	<ul style="list-style-type: none"> ▪ ≤ 1 mA (DC) ▪ ≤ 2 mA (AC)

Power supply

Terminal assignment

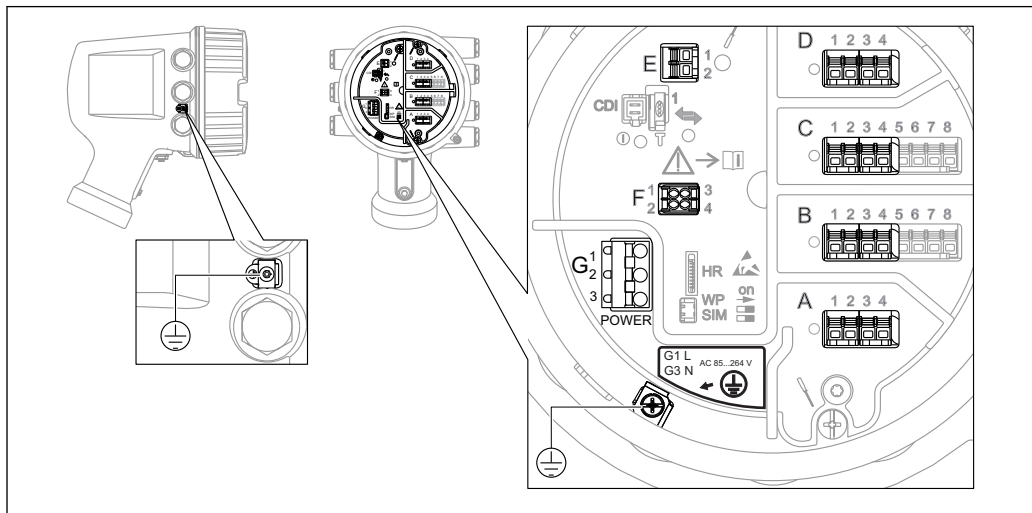

A0026372

7 Terminal compartment (typical example) and ground terminals

Terminal area	Module
A/B/C/D	<p>Up to four I/O modules, depending on the order code → 9</p> <ul style="list-style-type: none"> Modules with four terminals can be in any of these slots. Modules with eight terminals can be in slot B or C. <p>i The exact assignment of the modules to the slots is dependent on the device version. For a detailed description refer to the Operating Instructions of the device in question.</p>
E	<p>HART Ex i/IS interface</p> <ul style="list-style-type: none"> E1: H+ E2: H-
F	Remote display (in preparation)
G	<p>Power supply: 85 to 264 V_{AC}</p> <ul style="list-style-type: none"> G1: L G2: not connected G3: N
	<p>Protective ground connection</p> <p>A0018339</p>

Supply voltage

100 to 240 V_{AC}

Cable entries

Ordering feature 090 "Electrical Connection" ¹⁾	Cable entries (with blind plugs)
A	7 x thread M20
B	7 x thread M25
C	7 x thread G1/2
D	7 x thread G3/4
E	7 x thread NPT1/2
F	7 x thread NPT3/4

1) Position 13 of the order code, e.g. NMx8x-xxxxxxxxxxxxxA...



For the following devices with TIIS Ex d approval, cable glands are attached to the device (see position 1 and 2 of the order code). These cable glands must be used.

- Micropilot NMR84-TA...
- Micropilot NMR84-TC...
- Micropilot NMR84-TE...

Cable specification

Terminals

Terminal	Wire cross section
Signal and power supply <ul style="list-style-type: none"> ▪ Spring terminals (NMx8x-xx1...) ▪ Screw terminals (NMx8x-xx2...) 	0.2 to 2.5 mm ² (24 to 13 AWG)
Ground terminal in the terminal compartment	max. 2.5 mm ² (13 AWG)
Ground terminal at the housing	max. 4 mm ² (11 AWG)

Power supply line

Standard device cable is sufficient for the power line.

HART communication line

- Standard device cable is sufficient if only the analog signal is used.
- Shielded cable is recommended if using the HART protocol. Observe the grounding concept of the plant.

Modbus communication line

- Observe the cable conditions from the TIA-485-A, Telecommunications Industry Association.
- Additional conditions: Use shielded cable.

V1 communication line

- Two wire (twisted pair) screened or un-screened cable
- Resistance in one cable: ≤ 120 Ω
- Capacitance between lines: ≤ 0.3 μF

Overvoltage protection

On the communication and power lines; according to IEC 60060-1 /DIN 60079-14:
10 kA, 8/20 μs, 10 pulses according to IEC 60060-1 / DIN 60079-14

Performance characteristics

Reference operating conditions	According to OIML R85 (2008) <ul style="list-style-type: none"> ▪ Temperature: -25 to +55 °C (-13 to 131 °F) ▪ Atmospheric pressure ▪ Relative humidity (air): 65 % ±15 % ▪ Medium with good reflectivity and calm surface ▪ No major interference reflections inside the signal beam
---------------------------------------	--

Measured value resolution	≤ 0.1 mm (0.004 in)
----------------------------------	---------------------

Maximum measured error	The following values are valid for a measuring distance up to 30 m (100 ft)
-------------------------------	---

Ordering feature 150 "Accuracy, Weight + Measure Approval" ¹⁾	Maximum measured error
<ul style="list-style-type: none"> ▪ NTA: Maximum Performance, NMI type approval (in preparation) ▪ PTA: Maximum Performance, PTB type approval (in preparation) 	±0.5 mm ($\pm\frac{1}{32}$ in)
<ul style="list-style-type: none"> ▪ NTC: Custody transfer type approval according to NMI (in preparation) ▪ PTC: Custody transfer type approval according to PTB (in preparation) 	±1 mm ($\pm\frac{1}{16}$ in)
<ul style="list-style-type: none"> ▪ ICR: Standard version, w/o calibration certificate ▪ ICW: Standard version, 3-point calibration certificate ▪ ICX: Standard version, 5-point calibration certificate 	±1 mm ($\pm\frac{1}{16}$ in)

1) Position 21 to 23 in the order code (e.g. NMR8x-xxxxxxxxxxxxxxxxxxxxxICR...)

Hysteresis	0.2 mm (0.008 in)
-------------------	-------------------

Repeatability	0.2 mm (0.008 in)
----------------------	-------------------

Linearity	Within maximum measured error
------------------	-------------------------------

Long-term drift	Within the specified error of measurement
------------------------	---

Influence of ambient temperature	Within the specified accuracy according to OIML R85 (2008)
---	--

Installation

Installation conditions

Conditions for the stilling well

- Metal (no enamel coating)
- Constant diameter (no rectangular stilling wells)
- Weld seam as smooth as possible
- For best radar propagation behavior it is recommended to have holes instead of slots. If slots can not be avoided, they should be as thin and short as possible.
- Maximum gap between antenna/horn and wall of the stilling well: 5 mm (0.2 in).
- At any transition (e.g. when using a ball valve or mending pipe segments) gaps must not exceed 1 mm (0.04 in).
- The stilling well must be smooth on the inside. Average roughness $\leq 6.3 \mu\text{m}$ (0.248 μin)
- Length and number of the holes do not affect the measurement. The hole diameter (deburred) can be 1/7 of the well diameter, but should not exceed 25 mm (1 in).
- An increase of the pipe diameter is possible if the minimum lengths according to the following figure and table are taken into account:

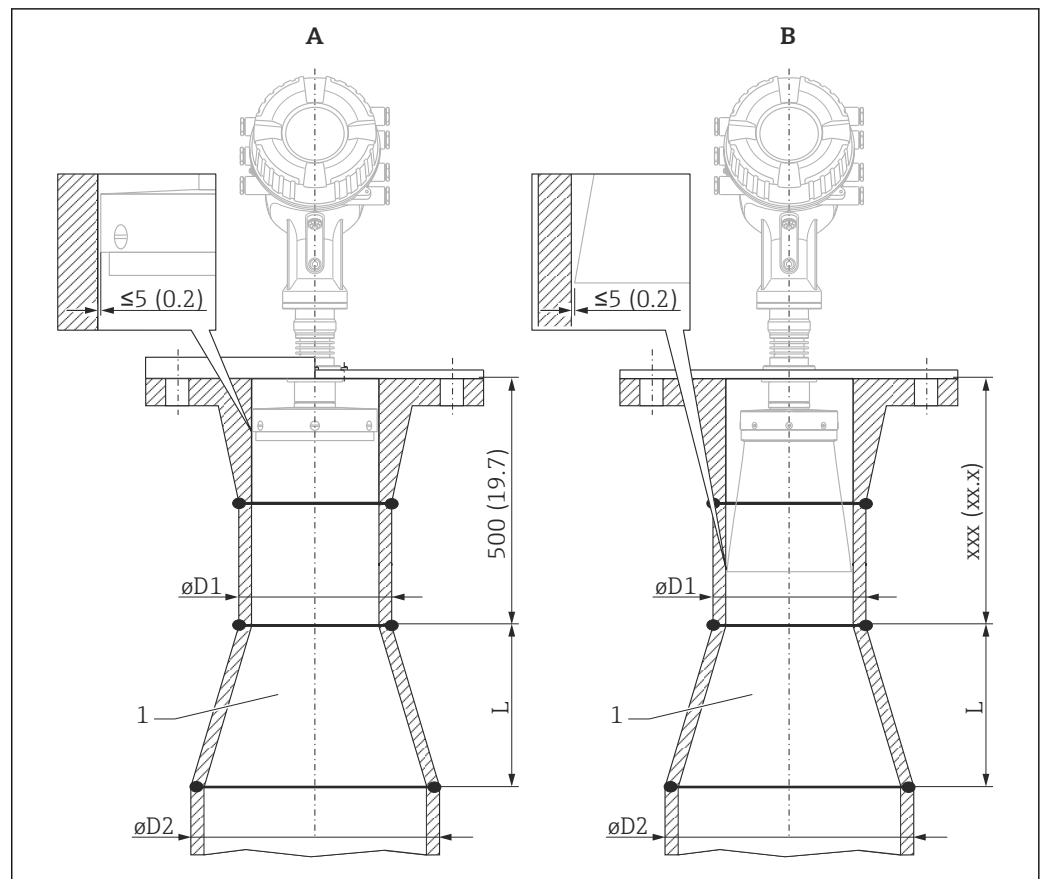

A0023596

8 Installation of NMR84 in stilling wells with a larger diameter

- A Antenna 150 mm (6 in) (without horn extension)
- B Antenna ≥ 200 mm (8 in) (with horn extension)
- 1 Extension from ØD1 to ØD2

D1 (= antenna size)	D2	L
150 mm (6 in)	200 mm (8 in)	300 mm (12 in)
200 mm (8 in)	250 mm (10 in)	300 mm (12 in)
250 mm (10 in)	300 mm (12 in)	450 mm (18 in)

Environment

Ambient temperature range

Device	-40 to +60 °C (-40 to +140 °F)
Display module	-20 to +70 °C (-4 to +158 °F)  The readability of the display may be impaired at temperatures outside this temperature range.

Ambient temperature limits

 The following diagrams take into account only functional aspects. There may be further restrictions for certified device versions. Please refer to the separate Safety Instructions.

Device configuration

The ambient temperature limits depend on the I/O modules present in the slots of the terminal compartment. Data are given for the following five typical configurations:

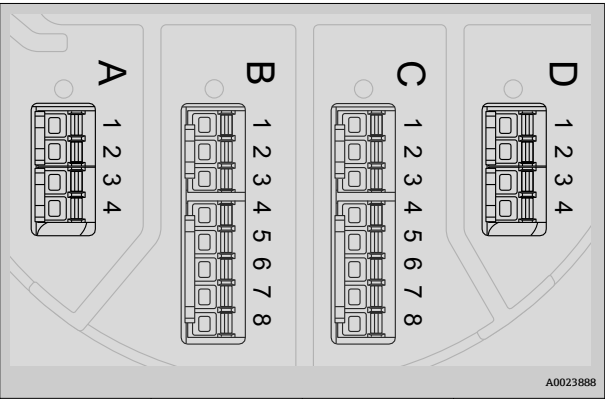
I/O configuration				
	A	B	C	D
1 (worst case)	✓	✓	✓	✓
2 (best case)	-	-	-	-
3	✓	✓	-	-
4	✓	-	-	-
5	✓	✓	-	✓

With a temperature (T_p) at the process connection the admissible ambient temperature (T_a) is reduced according to the following diagram (temperature derating):

Ambient temperature limits for NMR81

Temperature unit: °C (°F)

I/O configuration	P1		P2		P3		P4		P5	
	T_p	T_a	T_p	T_a	T_p	T_a	T_p	T_a	T_p	T_a
1	-40 (-40)	55 (131)	55 (131)	55 (131)	150 (302)	50 (122)	150 (302)	-40 (-40)	-40 (-40)	-40 (-40)
2	-40 (-40)	60 (140)	60 (140)	60 (140)	150 (302)	57 (135)	150 (302)	-40 (-40)	-40 (-40)	-40 (-40)
3	-40 (-40)	55 (131)	55 (131)	55 (131)	150 (302)	53 (127)	150 (302)	-40 (-40)	-40 (-40)	-40 (-40)
4	-40 (-40)	60 (140)	60 (140)	60 (140)	150 (302)	55 (131)	150 (302)	-40 (-40)	-40 (-40)	-40 (-40)
5	-40 (-40)	55 (131)	55 (131)	55 (131)	150 (302)	52 (125)	150 (302)	-40 (-40)	-40 (-40)	-40 (-40)

Classification of environmental conditions according to DIN EN 60721-3-4

4K5, 4K6, 4B1, 4M7, 4Z2, 4Z3, 4Z8

Storage temperature

-50 to +80 °C (-58 to +176 °F)

Humidity

≤ 95 %

Degree of protection

- IP68/66 according to DIN EN 60529
- Type 6P/4x according to NEMA 250

Shock resistance

- 30 g (18 ms) according to DIN EN 60068-2-27 (1993)
- Classification according to DIN EN 60721-3-4: 4M7

Vibration resistance

- 20 to 2 000 Hz, 1 (m/s²)/Hz according to DIN EN 60068-2-64 (1994)
- This corresponds to an acceleration value of 4.5 g and fulfills class 4M7 of DIN EN 60721-3-4 (1995)

Electromagnetic compatibility (EMC)

- Transient emissions according to DIN EN 61326, class B
- Interference resistance according to DIN EN 61326, Appendix A (Industry use) and NAMUR recommendation NE21

Process

Process temperature range	Device	Process temperature range
	NMR84	-40 to +150 °C (-40 to +302 °F)

Process pressure range	Device	Process pressure range
	NMR84	-1 to +25 bar (-14.5 to +362 psi)

Dielectric constant	Application	Dielectric constant
	Stilling well	$\epsilon_r \geq 1.4$

Custody transfer approval

Ordering feature 150 "Accuracy, Weight + Measure Approval" ¹⁾	Accuracy properties
ICR	Standard version (± 1 mm), without calibration certificate
ICW	Standard version (± 1 mm), 3-point calibration certificate
ICX	Standard version (± 1 mm), 5-point calibration certificate
NTA (in preparation)	Maximum performance (± 0.5 mm), type approval according to NMI, OIML R85, API 3.1B, ISO4622, factory calibration certificate
NTC (in preparation)	Custody transfer (± 1 mm) type approval according to NMI, OIML R85, API 3.1B, ISO4622, factory calibration certificate
PTA (in preparation)	Maximum performance (± 0.5 mm), PTB type approval, factory calibration certificate
PTC (in preparation)	Custody transfer (± 1 mm) type approval per PTB, factory calibration certificate

1) Position 21 to 23 in the order code (e.g. NMR8x-xxxxxxxxxxxxxxxxxxxxxICR...)

 Micropilot NMR8x that are certified for Custody Transfer applications are calibrated on a certified production rig. The production rig reference standard is a laser tracker with an absolute accuracy of ± 0.016 mm and a resolution of 0.0001 mm. Calibration is performed at 10 equally-spaced measuring points over the full measuring range.

The Maximum Permissible Error (MPE) is ± 0.5 mm ($\pm \frac{1}{32}$ in) for Maximum performance models, and ± 1 mm ($\pm \frac{1}{16}$ in) for Custody transfer models. The resultant Factory Calibration Certificate is included in the scope of delivery along with the respective type approval certificate.

Mechanical construction

Dimensions

Housing

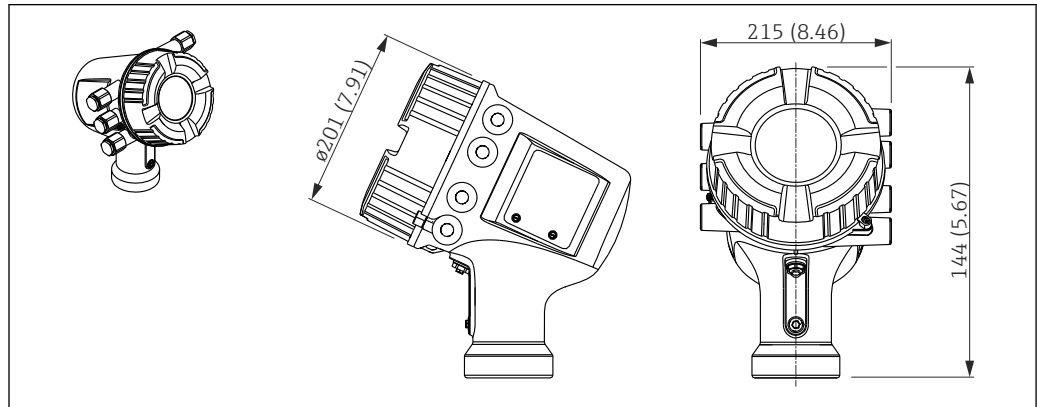

A0023482

9 Dimensions of the electronics housing; unit of measurement: mm (in); adapters for cable entries are not taken into account in this drawing.

Process connection and sensor

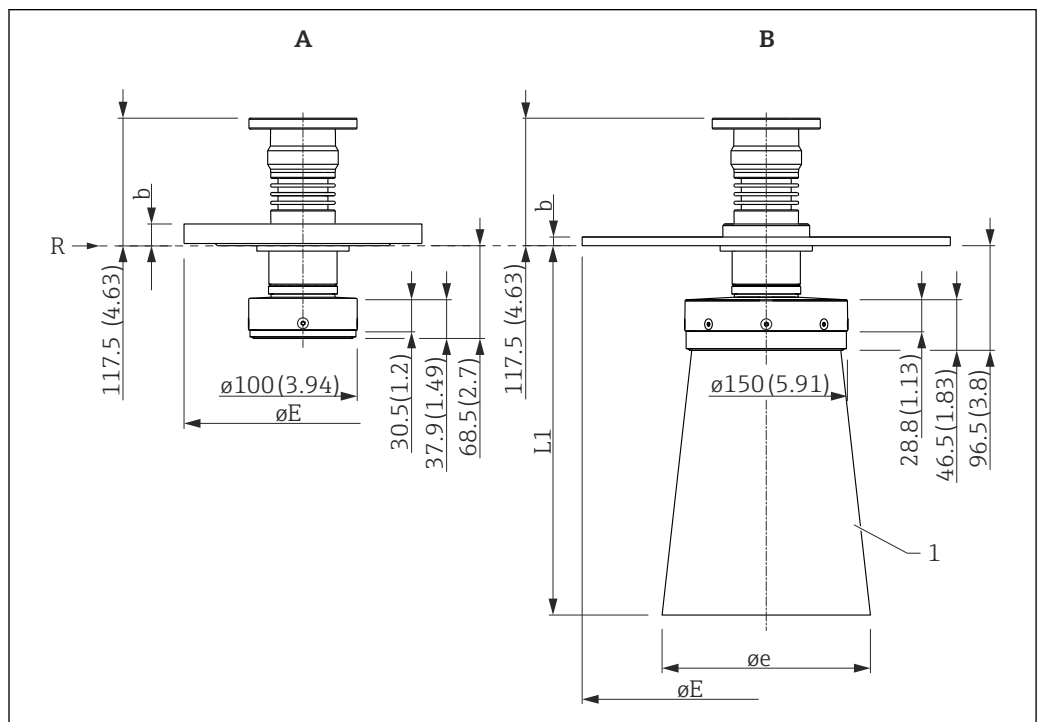

A0023485

10 Dimensions of the planar antenna (NMR84); unit of measurement: mm (in)

- A Planar antenna 100mm/4"
- B Planar antenna 150mm/6" to 300mm/12"
- 1 Antenna extension for antennas ≥ 200 mm (8 in)
- R Reference point of the measurement

Antenna extension

Dimension	Ordering feature 100 "Antenna" ¹⁾				
	BD: Planar 100mm/4"	BF: Planar 150mm/6"	BG: Planar 200mm/8"	BH: Planar 250mm/10"	BJ: Planar 300mm/12"
e	-	-	192 mm (7.56 in)	242 mm (9.53 in)	292 mm (11.5 in)
L1	-	-	341 mm (13.4 in)	494 mm (19.4 in)	521 mm (20.5 in)

1) Position 14 and 15 of the order code

Flanges according to ASME B16.5

Pressure rating ¹⁾	Dimension	Nominal diameter ¹⁾			
		4"	6"	8"	10"
150 lbs	b	23.9 mm (0.94 in)	25.4 mm (1 in)	28.4 mm (1.12 in)	30.2 mm (1.19 in)
	φE	φ228.6 mm (9 in)	φ279.4 mm (11 in)	φ342.9 mm (13.5 in)	φ406.4 mm (16 in)
300 lbs	b	31.8 mm (1.25 in)	36.6 mm (1.44 in)	41.1 mm (1.62 in)	-
	φE	φ254 mm (10 in)	φ317.5 mm (12.5 in)	φ381 mm (15 in)	-

1) Ordering feature 140 (position 18 to 20 of the order code)

Flanges according to EN1092-1 (suitable for DIN2527)

Pressure rating ¹⁾	Dimension	Nominal diameter ¹⁾			
		DN100	DN150	DN200	DN250
<ul style="list-style-type: none"> ■ PN10 ■ PN16 	b	20 mm (0.79 in)	22 mm (0.87 in)	24 mm (0.94 in)	26 mm (1.02 in)
	φE	φ220 mm (8.66 in)	φ285 mm (11.2 in)	φ340 mm (13.4 in)	φ405 mm (15.9 in)
<ul style="list-style-type: none"> ■ PN25 ■ PN40 	b	24 mm (0.94 in)	28 mm (1.1 in)	30 mm (1.18 in)	-
	φE	φ235 mm (9.25 in)	φ300 mm (11.8 in)	φ360 mm (14.2 in)	-

1) Ordering feature 140 (position 18 to 20 of the order code)

Flanges according to JIS B2220

Pressure rating ¹⁾	Dimension	Nominal diameter ¹⁾	
		100A	150A
10 K	b	18 mm (0.71 in)	22 mm (0.87 in)
	φE	φ210 mm (8.27 in)	φ280 mm (11 in)
20 K	b	24 mm (0.94 in)	28 mm (1.1 in)
	φE	225 mm (8.8 in)	φ305 mm (12 in)

1) Ordering feature 140 (position 18 to 20 of the order code)

Flanges according to JPI 7S-15

Pressure rating Nominal diameter ¹⁾	Dimension	Nominal diameter ¹⁾	
		100A	150A
150 lbs	b	23.9 mm (0.94 in)	25.4 mm (1 in)
	φE	φ228.6 mm (9 in)	φ279.4 mm (11 in)
300 lbs	b	31.8 mm (1.25 in)	-
	φE	φ254 mm (10 in)	-

1) Ordering feature 140 (position 18 to 20 of the order code)

UNI flanges

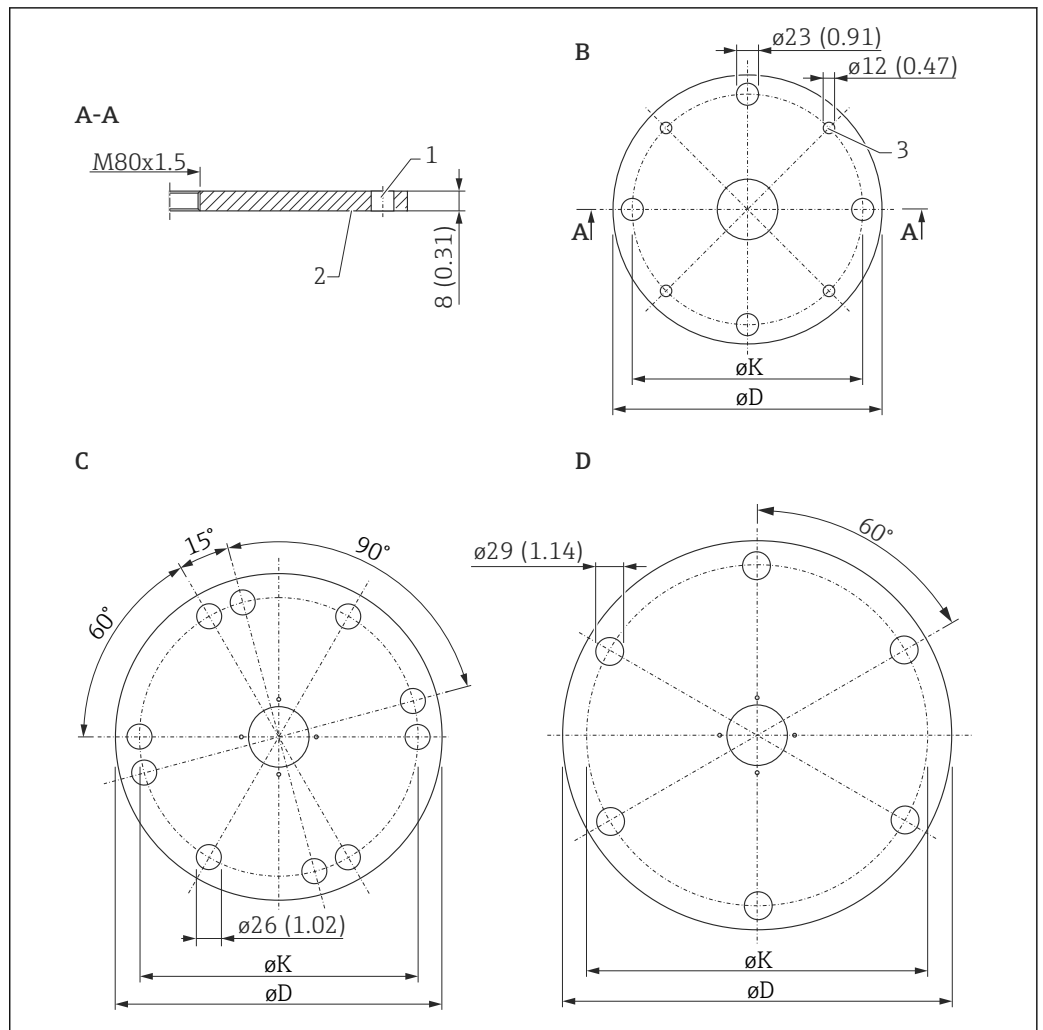

A0027691

11 UNI flanges

- B UNI flange DN150/6"/150
- C UNI flange DN200/8"/200
- D UNI flange DN250/10"/250

Position	Option of ordering feature 140 ("Process Connection") ¹⁾	Suitable for	$\varnothing D$	$\varnothing K$	Material
B	RKJ	<ul style="list-style-type: none"> ▪ DN150, PN10/16 (EN1092-1) ▪ NPS 6" Cl. 150 (ASME B16.5) ▪ 10K 150A (JIS B2220) 	280 mm (11.0 in)	240 mm (9.45 in)	1.4301
C	RLJ	<ul style="list-style-type: none"> ▪ DN200, PN10/16 (EN1092-1) ▪ NPS 8" Cl. 150 (ASME B16.5) ▪ 10K 200A (JIS B2220) 	340 mm (13.4 in)	294.5 mm (11.6 in)	
D	RMJ	<ul style="list-style-type: none"> ▪ DN250, PN10/16 (EN1092-1) ▪ NPS 10" Cl. 150 (ASME B16.5) ▪ 10K 250A (JIS B2220) 	405 mm (15.9 in)	358 mm (14.1 in)	

1) Position 18 to 20 of the order code)

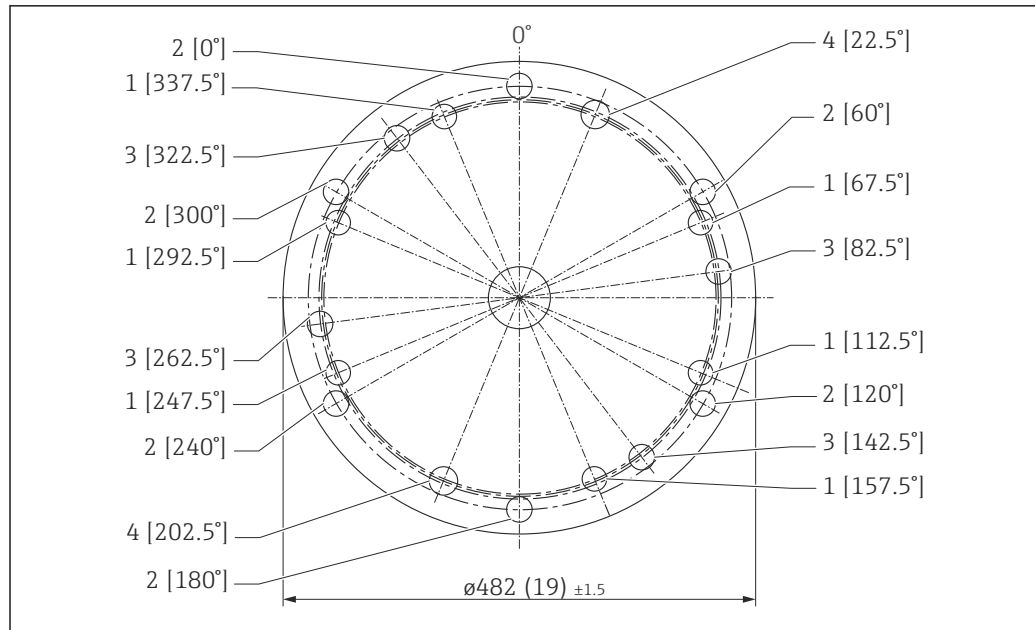

12 UNI flange DN300/12"/300

- 1 Bores for 10K 300A (JIS B2220)
- 2 Bores for NPS 12" Cl.150 (ASME B16.5)
- 3 Bores for DN300 PN10/16 (EN1092-1)
- 4 Bores for DN300 PN10/16 (EN1092-1) and 10K 300A (JIS B2220)

Option of ordering feature 140 ("Process Connection") ¹⁾	Suitable for	Material
RNJ	<ul style="list-style-type: none"> ■ DN300, PN10/16 (EN1092-1) ■ NPS 12" Cl. 150 (ASME B16.5) ■ 10K 300A (JIS B2220) 	1.4301

1) Position 18 to 20 of the order code)

Weight

- Housing with electronics: approx. 12 kg (26 lb)
- Sensor and process connection: 8.5 to 43 kg (19 to 95 lb); dependent on the device version

Materials

Materials of housing

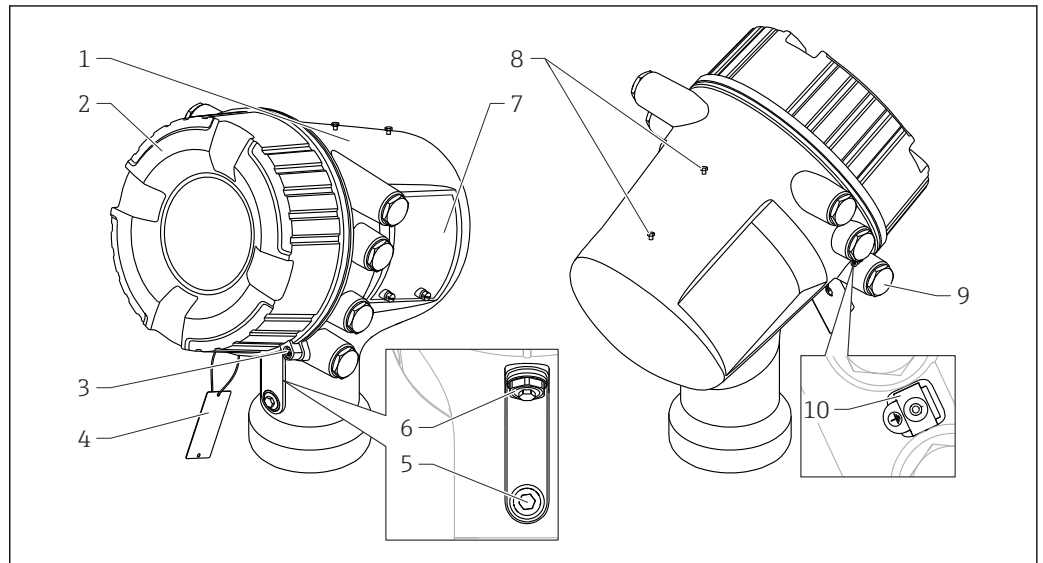

A0027788

Pos.	Part	Materials for Aluminum version ¹⁾	Materials for stainless steel version ²⁾
1	Housing	AC 43000 T6	316L (1.4404)
2	Cover	<ul style="list-style-type: none"> ▪ Cover: AC 43000 T6 ▪ Window: Glass ▪ Seal: FVMQ ▪ Thread-coating: Graphite-based lubricant varnish 	<ul style="list-style-type: none"> ▪ Cover: 316L (1.4404) ▪ Window: Glass ▪ Seal: FVMQ ▪ Thread-coating: Graphite-based lubricant varnish
3	Cover lock	<ul style="list-style-type: none"> ▪ Capstan screw: 316L (1.4404) ▪ Clamp: 316L (1.4435) 	<ul style="list-style-type: none"> ▪ Capstan screw: 316L (1.4404) ▪ Clamp: 316L (1.4435)
4	Tag for measuring point label	316L (1.4404)	316L (1.4404)
5	Pressure release stopper for Ex i/IS chamber	316L (1.4404)	316L (1.4404)
6	Pressure release stopper for Ex d/XP chamber	<ul style="list-style-type: none"> ▪ Stopper: 316L (1.4404) ▪ O-ring: EPDM 	<ul style="list-style-type: none"> ▪ Stopper: 316L (1.4404) ▪ O-Ring: EPDM
7	Nameplate	<ul style="list-style-type: none"> ▪ Sticker: Plastic ▪ Sealing screw: A4 ▪ O-ring: FKM 	<ul style="list-style-type: none"> ▪ Nameplate: 316L (1.4404) ▪ Groove pins: 316Ti (1.4571) ▪ Sealing screw: A4 ▪ O-ring: FKM
8	Dummy screws for weather protection cover	<ul style="list-style-type: none"> ▪ Screw: A4-70 ▪ O-ring: EPDM 	<ul style="list-style-type: none"> ▪ Screw: A4-70 ▪ O-ring: EPDM

Pos.	Part	Materials for Aluminum version ¹⁾	Materials for stainless steel version ²⁾
9	Dummy plug, cable gland or adapter ³⁾	<ul style="list-style-type: none"> ▪ Dummy plug <ul style="list-style-type: none"> - 1.4435 - LD-PE ▪ Adapter: <ul style="list-style-type: none"> - Ms/Ni (TIIS) - 1.4404 (other versions) ▪ Seal: <ul style="list-style-type: none"> - EPDM - NBR - PTFE tape 	<ul style="list-style-type: none"> ▪ Dummy plug <ul style="list-style-type: none"> - 1.4435 - LD-PE ▪ Adapter: <ul style="list-style-type: none"> - Ms/Ni (TIIS) - 1.4404 (other versions) ▪ Seal: <ul style="list-style-type: none"> - EPDM - NBR - PTFE tape
10	Ground terminal	<ul style="list-style-type: none"> ▪ Screw: A4-70 ▪ Spring washer: A4 ▪ Clamp and holder: 316L (1.4404) 	<ul style="list-style-type: none"> ▪ Screw: A4-70 ▪ Spring washer: A4 ▪ Clamp and holder: 316L (1.4404)

1) Ordering feature 070 "Housing", Option "AA"; position 11/12 of the order code: NXXXX-xxxxxxxxAA...

2) Ordering feature 070 "Housing", Option "BA"; position 11/12 of the order code: NXXXX-xxxxxxxxBA...

3) Depending on device version

Materials of antenna and process connection

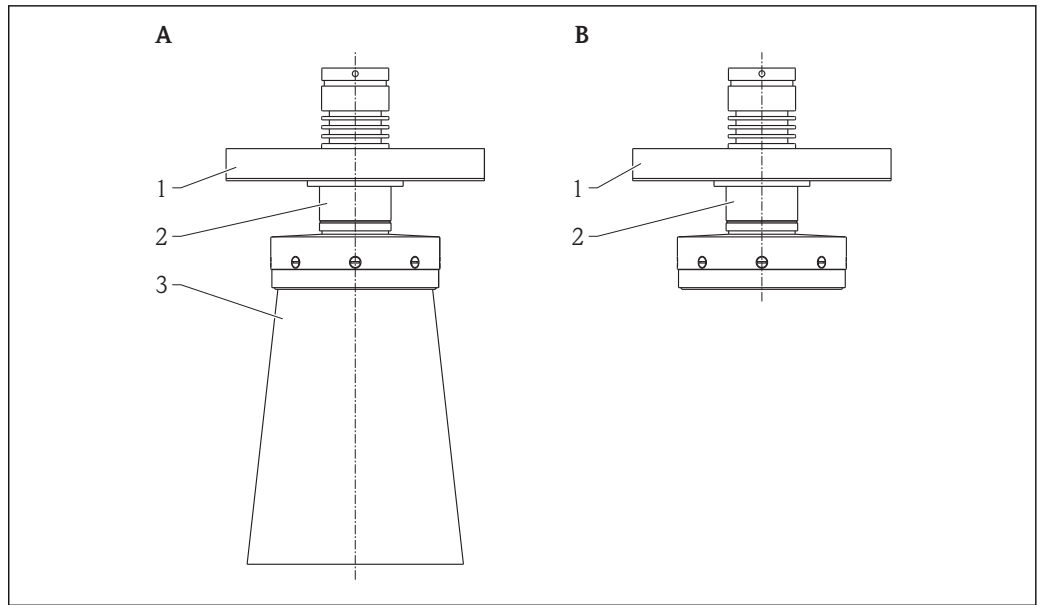

A0018957

- A Version with antenna extension (\geq DN200/8")
 B Version without antenna extension (DN100/4", DN150/6")

Pos.	Part	Material
1	Flange	ASME/EN/JIS/JPI: 316L (1.4404/1.4435)
	Adapter	316L (1.4404)
2	Housing adapter	316L (1.4404)
	Sensor adapter	316L (1.4404)
	Housing and retaining ring	316L (1.4404)
	Screw	A2
	Planar antenna	PTFE
	Sealing ring	FKM /HNBR / FFKM
3	Antenna extension	316L (1.4404)

Operability

Operating concept

Operator-oriented menu structure for user-specific tasks

- Commissioning
- Operation
- Diagnostics
- Expert level

Operating languages

- English
- German
- Japanese

 Feature 500 of the product structure determines which of these languages is preset on delivery.

Quick and safe commissioning

- Guided menus ("Make-it-run" wizards) for applications
- Menu guidance with brief explanations of the individual parameter functions

Reliable operation

Standardized operation at the device and in the operating tools

Efficient diagnostics increase measurement reliability

- Remedy information is integrated in plain text
- Diverse simulation options

Operating options

- Local display; operation via the local display is possible without opening the device.
- Tank Gauging system
- Plant Asset Management tool (e.g. FieldCare); connected via
 - HART
 - Service port (CDI)

Local operation

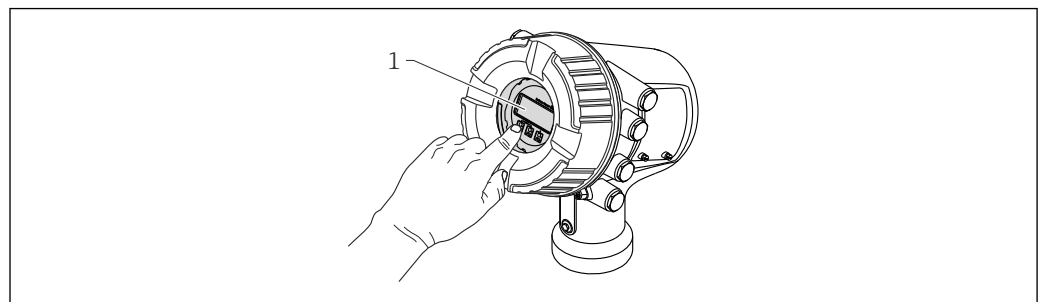



 13 Local operation of the Micropilot NMR81/NMR84

1 Display and operating module

Display elements

- 4-line display
- White background lighting; switches to red in event of device errors
- Format for displaying measured variables and status variables can be individually configured
- Permitted ambient temperature for the display: -20 to $+70$ °C (-4 to $+158$ °F)
The readability of the display may be impaired at temperatures outside the temperature range.

Operating elements

- External operation via touch control; 3 optical keys: , , 
- Operating elements also accessible in various hazardous areas

Remote operation

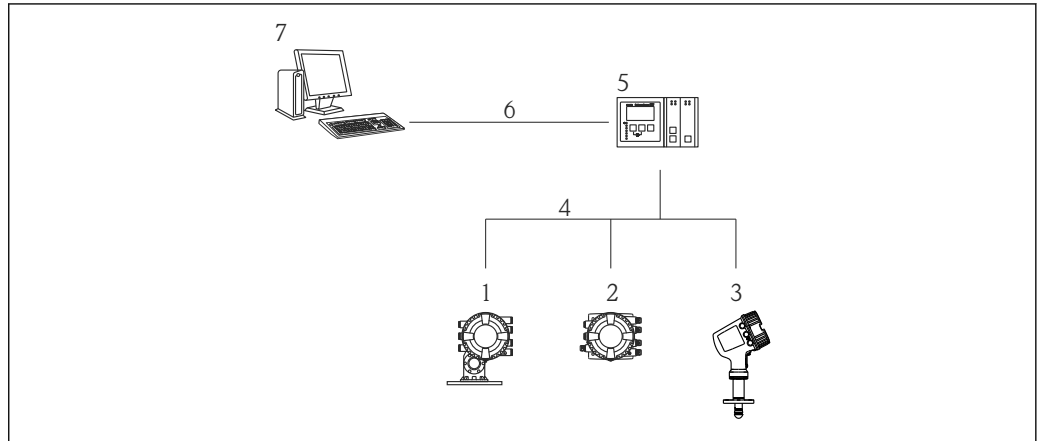

A0025621

14 Remote operation of Tank Gauging devices

- 1 Proservo NMS8x
- 2 Tankside Monitor NRF81
- 3 Micropilot NMR8x
- 4 Field protocol (e.g. Modbus, V1)
- 5 Tankvision Tank Scanner NXA820
- 6 Ethernet
- 7 Computer with operating tool (e.g. FieldCare)

Operation via service interface

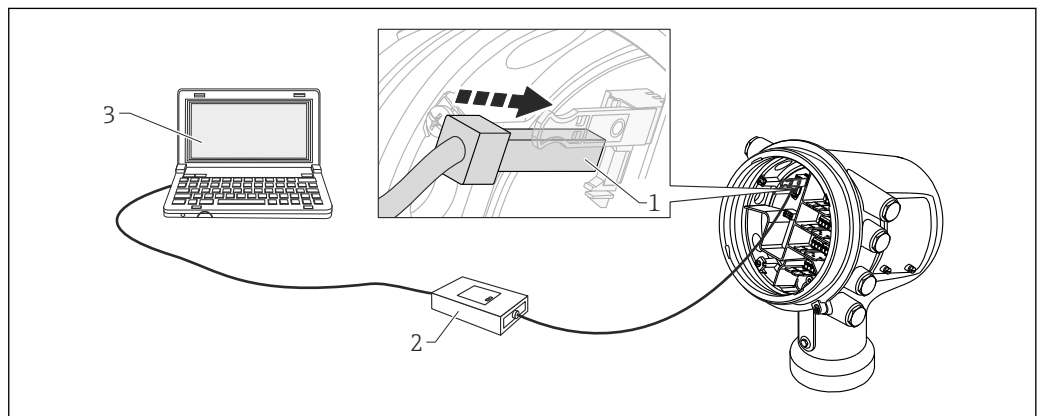





A0023737

15 Operation via service interface

- 1 Service interface (CDI = Endress+Hauser Common Data Interface)
- 2 Commubox FXA291
- 3 Computer with "FieldCare" operating tool and "CDI Communication FXA291" COM DTM

Certificates and approvals

CE mark	<p>The measuring system meets the legal requirements of the applicable EC guidelines. These are listed in the corresponding EC Declaration of Conformity together with the standards applied.</p> <p>Endress+Hauser confirms successful testing of the device by affixing to it the CE mark.</p>
RCM-Tick marking	<p>The supplied product or measuring system meets the ACMA (Australian Communications and Media Authority) requirements for network integrity, interoperability, performance characteristics as well as health and safety regulations. Here, especially the regulatory arrangements for electromagnetic compatibility are met. The products are labelled with the RCM- Tick marking on the name plate.</p> <div data-bbox="402 571 1442 705" style="text-align: center;">  </div> <p style="text-align: right; font-size: small;">A0029561</p>
Ex approval	<p>The devices are certified for use in hazardous areas and the relevant safety instructions are provided in the separate "Safety Instructions" (XA) document. Reference is made to this document on the nameplate.</p> <p> The separate documentation "Safety Instructions" (XA) containing all the relevant explosion protection data is available from your Endress+Hauser Sales Center. Allocation of the XA to the device version: →  40</p>
Dual seal according to ANSI/ISA 12.27.01	<p>The devices have been designed according to ANSI/ISA 12.27.01 as dual seal devices, allowing the user to waive the use and save the cost of installing external secondary process seals in the conduit as required by the process sealing sections of ANSI/NFPA 70 (NEC) and CSA 22.1 (CEC). These instruments comply with the North-American installation practice and provide a very safe and cost-saving installation for pressurized applications with hazardous fluids.</p> <p>Further information can be found in the Safety Instructions (XA) of the relevant devices.</p>
Functional Safety (SIL)	in preparation
WHG	in preparation
Weight & Measure approval	<ul style="list-style-type: none"> ▪ OIML R85 (2008) (in preparation) ▪ NMI (in preparation) ▪ PTB (in preparation) ▪ PAC (in preparation) ▪ LNE (in preparation) ▪ WELMEC (in preparation) ▪ GOST (in preparation) <p> The device has a sealable locking switch according to the Weight & Measure requirements. This switch locks all software parameters related to the measurement. The switching status is indicated on the display and via the communication protocol.</p>
Radio standard EN302372-1/2	<p>The devices are conform with the TLPR (Tanks Level Probing Radar) standard EN302372-1/2 and can always be used in closed tanks or bins. For installation, points a to f in Annex B of EN302372-1 have to be taken into account.</p>
FCC / Industry Canada	<p>This device complies with Part 15 of the FCC rules. Operation is subject to the following two conditions: (1) This device may not cause harmful interference, and (2) this device must accept any interference received, including interference that may cause undesired operation.</p> <p>This device complies with Industry Canada licence-exempt RSS standard(s). Operation is subject to the following two conditions: (1) This device may not interference, and (2) this device must accept any interference, including interference that may cause undesired operation of the device.</p> <p><i>Le présent appareil est conforme aux CNR d'Industrie Canada applicables aux appareils radio exempts de licence. L'exploitation est autorisée aux deux conditions suivantes : (1) l'appareil ne doit pas</i></p>

produire de brouillage, et (2) l'utilisateur de l'appareil doit accepter tout brouillage radioélectrique subi, même si le brouillage est susceptible d'en compromettre le fonctionnement.

[Any] changes or modifications not expressly approved by the party responsible for compliance could void the user's authority to operate the equipment.

Non-ionizing radiation protection

According to guideline 2004/40/EG-ICNIRP Guidelines EN50371

Test, certificate

Ordering feature 580 "Test, Certificate"	Designation
JA	3.1 Material certificate, wetted metallic parts, EN10204-3.1 inspection certificate
JB	Conformity to NACE MR0175, wetted metallic parts
JE	Conformity to NACE MR0103, wetted metallic parts
KD	Helium leak test, internal procedure, inspection certificate
KE	Pressure test, internal procedure, inspection certificate
KG	PMI test (XRF), internal procedure, wetted metallic parts, inspection certificate
KP	Liquid penetrant test AD2000-HP5-3(PT), wetted/pressurized metallic parts, inspection certificate
KQ	Liquid penetrant test ISO23277-1 (PT), wetted/pressurized metallic parts, inspection certificate
KR	Liquid penetrant test ASME VIII-1 (PT), wetted/pressurized metallic parts, inspection certificate
KS	Welding documentation, wetted/pressurized seams

Other standards and guidelines

Industry standards

- Directive 2002/95/EC: "Restriction of Hazardous Substances Directive" (RoHS)
- Directive 2004/22/EC: "Measuring Instruments Directive" (MID)
- Directive 97/23/EC: "Pressure Equipment Directive" (PED)
- IEC61508: "Functional Safety of Electrical/Electronic/Programmable Electronic Safety-related Systems" (SIL)
- NACE MR 0175, NACE MR 0103: "Sulfide stress cracking resistant metallic materials for oilfield equipment"
- API Recommended Practice 2350: "Overfill Protection for Storage Tanks in Petroleum Facilities"
- API MPMS: "Manual of Petroleum Measurement Standards"
- EN 1127: "Explosive atmospheres - Explosion prevention and protection"
- IEC 60079: "Equipment protection"
- EN 1092: "Flanges and their joints"
- EN 13463: "Non-electrical equipment for use in potentially explosive atmospheres"
- TIA-485-A: "Electrical Characteristics of Generators and Receivers for Use in Balanced Digital Multipoint Systems"
- IEC61511: "Functional safety - Safety instrumented systems for the process industry sector"
- IEEE 754: "Standard for Binary Floating-Point Arithmetic for microprocessor systems"
- ISO4266: "Petroleum and liquid petroleum products - measurement of level and temperature in storage tanks by automatic methods"
- ISO6578: "Refrigerated hydrocarbon liquids - Static measurement - Calculation procedure"
- ISO 11223: "Petroleum and liquid petroleum products - Determination of volume, density and mass of the contents of vertical cylindrical tanks by Hybrid Tank Measurement Systems"
- ISO15169: "Petroleum and liquid petroleum products - Direct static measurement - Measurement of content of vertical storage tanks by hydrostatic tank gauging"
- JIS K2250: "Petroleum Measurement Tables"
- JIS B 8273: "Bolted flange for pressure vessels"
- G.I.I.G.N.L.: "LNG Custody transfer handbook"
- NAMUR NEO43: "Standardization of the Signal Level for the Failure Information of Digital Transmitters"
- NAMUR NE107: "Self-Monitoring and Diagnosis of Field Devices"
- PTBA-A-4.2: "Volume measuring devices for liquids in a stationary condition - Storage containers and their measuring devices"

Metrological standards

- OIML R85 (2008) "Requirements for ambient temperature low $-25\text{ }^{\circ}\text{C}$ ($-13\text{ }^{\circ}\text{F}$) and ambient temperature high $+55\text{ }^{\circ}\text{C}$ ($+131\text{ }^{\circ}\text{F}$)
- "Mess- und Eichverordnung" (Calibration regulations for the Federal Republic of Germany)
- Directive 2004/22/EC of the European Parliament and of the Council of 31 March 2004 on measuring instruments

Ordering information

Ordering information

Detailed ordering information is available from the following sources:

- In the Product Configurator on the Endress+Hauser website: www.endress.com -> Click "Corporate" -> Select your country -> Click "Products" -> Select the product using the filters and search field -> Open product page -> The "Configure" button to the right of the product image opens the Product Configurator.
- From your Endress+Hauser Sales Center: www.addresses.endress.com



Product Configurator - the tool for individual product configuration

- Up-to-the-minute configuration data
- Depending on the device: Direct input of measuring point-specific information such as measuring range or operating language
- Automatic verification of exclusion criteria
- Automatic creation of the order code and its breakdown in PDF or Excel output format
- Ability to order directly in the Endress+Hauser Online Shop

Calibration certificate

Option of ordering feature 150 "Accuracy, Weight + Measure Approval" ¹⁾	Calibration certificate	Position of the calibration points ²⁾
ICW	3-point	<ul style="list-style-type: none"> ▪ 2 m (6.6 ft) ▪ 15 m (49 ft) ▪ 30 m (98 ft)
ICX	5-point	<ul style="list-style-type: none"> ▪ 2 m (6.6 ft) ▪ 9 m (30 ft) ▪ 15 m (49 ft) ▪ 21 m (69 ft) ▪ 30 m (98 ft)
<ul style="list-style-type: none"> ▪ NTA (in preparation) ▪ NTC (in preparation) ▪ PTA (in preparation) ▪ PTC (in preparation) 	10-point	<ul style="list-style-type: none"> ▪ 2 m (6.6 ft) ▪ 6 m (20 ft) ▪ 9 m (30 ft) ▪ 12 m (39 ft) ▪ 15 m (49 ft) ▪ 18 m (59 ft) ▪ 21 m (69 ft) ▪ 24 m (79 ft) ▪ 27 m (89 ft) ▪ 30 m (98 ft)

1) Positions 21 to 23 of the order code

2) Distance measured from the lower edge of the mounting flange



The position of the calibration points may vary by ± 1 cm (± 0.04 in).



The calibration points are checked under reference conditions.

Customized parametrization

Option of ordering feature 570 "Service"	Meaning
IJ	Customized parametrization HART (in preparation)
IX	Customized parametrization V1 (in preparation)
IZ	Customized parametrization Modbus (in preparation)

If one of these options has been selected, customer specific presets can be selected for the following parameters:

Parameter	Selection list / range of values
Tank reference height	0 to 999 999.9 mm

Marking

Option of ordering feature 895 "Marking"	Meaning
Z1	Tagging (TAG)
Z2	Bus address

Optionally, the device can be ordered with a specific tagging and/or bus address according to the table above. When the respective option is selected, the tag or bus address must be defined in an additional specification.

Application packages

Advanced tank measurement methods

The device software provides the following tank measurement methods:

- Direct level measurement → 35
- Hybrid tank measurement system (HTMS) → 36
- Hydrostatic tank shell correction (HyTD) → 37
- Thermal tank shell correction (CTSh) → 37

Direct level measurement

If no advanced tank measurement methods have been selected, level and temperature are measured directly.

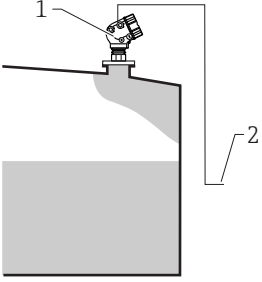
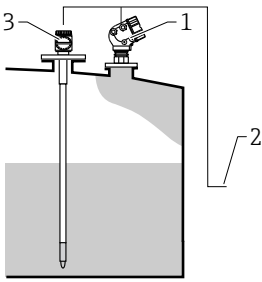

Direct level measurement modes

Measuring mode	Installation example	Measured variables	Calculated variables
Level only	 <p style="text-align: right; margin-right: 50px;">A0027111</p> <p>1 Micropilot 2 To inventory management system</p>	Level	None
Level + temperature	 <p style="text-align: right; margin-right: 50px;">A0027112</p> <p>1 Micropilot 2 To inventory management system 3 Temperature transmitter (point or average)</p>	<ul style="list-style-type: none"> ■ Level ■ Temperature (point or average) 	None

Hybrid tank measurement system (HTMS)

HTMS uses level and pressure measurements to calculate the contents of the tank and (optionally) the density of the medium.

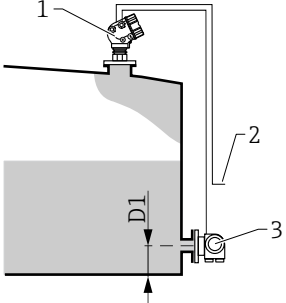
HTMS measuring modes

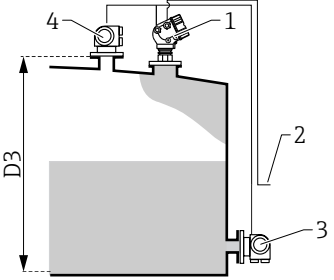
Measuring mode	Installation example	Measured variables	Calculated variables
<p>HTMS + P1</p> <p> This mode should be used in atmospheric (i.e. non-pressurized) tanks</p>	 <p style="text-align: right; font-size: small;">A0027113</p> <p>1 Micropilot 2 To inventory management system 3 Pressure transmitter (bottom)</p>	<ul style="list-style-type: none"> ■ Level ■ Bottom pressure (at position D1) 	<p>Density of the medium</p>
<p>HTMS + P1 + P3</p> <p> This mode should be used in non- atmospheric (i.e. pressurized) tanks</p>	 <p style="text-align: right; font-size: small;">A0027114</p> <p>1 Micropilot 2 To inventory management system 3 Pressure transmitter (bottom) 4 Pressure transmitter (top)</p>	<ul style="list-style-type: none"> ■ Level ■ Bottom pressure (at position D1) ■ Top pressure (at position D3) 	<p>Density of the medium</p>

Hydrostatic tank shell correction (HyTD)

The hydrostatic tank shell correction can be used to compensate for vertical movement of the Gauge Reference Height due to bulging of the tank shell caused by the hydrostatic pressure exerted by the liquid stored in the tank. The compensation is based on a linear approximation obtained from manual hand dips at several levels distributed over the full range of the tank.

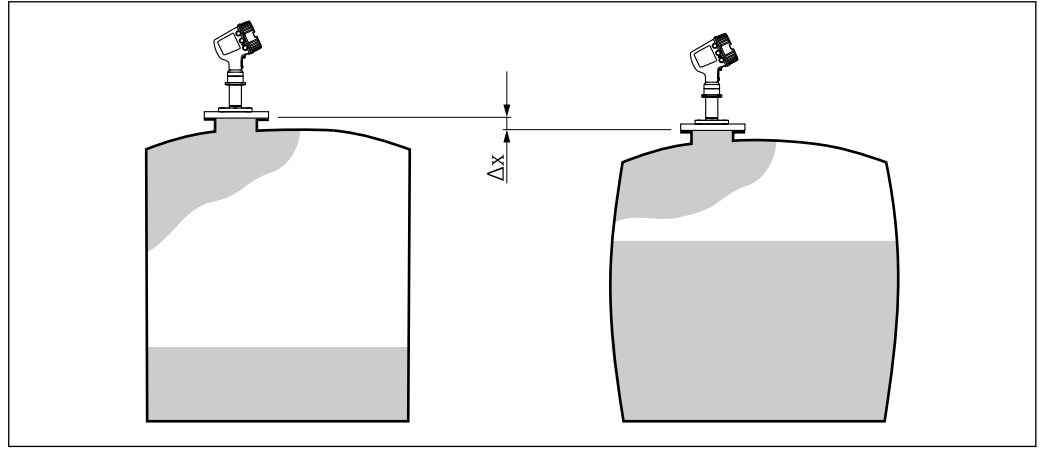

16 Movement Δx of the Gauge Reference Height due to the bulging of the tank shell caused by hydrostatic pressure

Thermal tank shell correction (CTSh)

The thermal tank shell correction can be used to compensate for vertical movement of the Gauge Reference Height due to temperature effects on the tank shell or stilling well. The calculation is based on the thermal expansion coefficients of steel and on insulation factors for both the dry and wetted part of the tank shell.

- i** This correction is recommended for any tank gauge operating at conditions deviating considerably from the conditions during calibration and for extremely high tanks. For refrigerated, cryogenic and heated applications this correction is highly recommended.

Accessories

Device-specific accessories

Weather protection cover

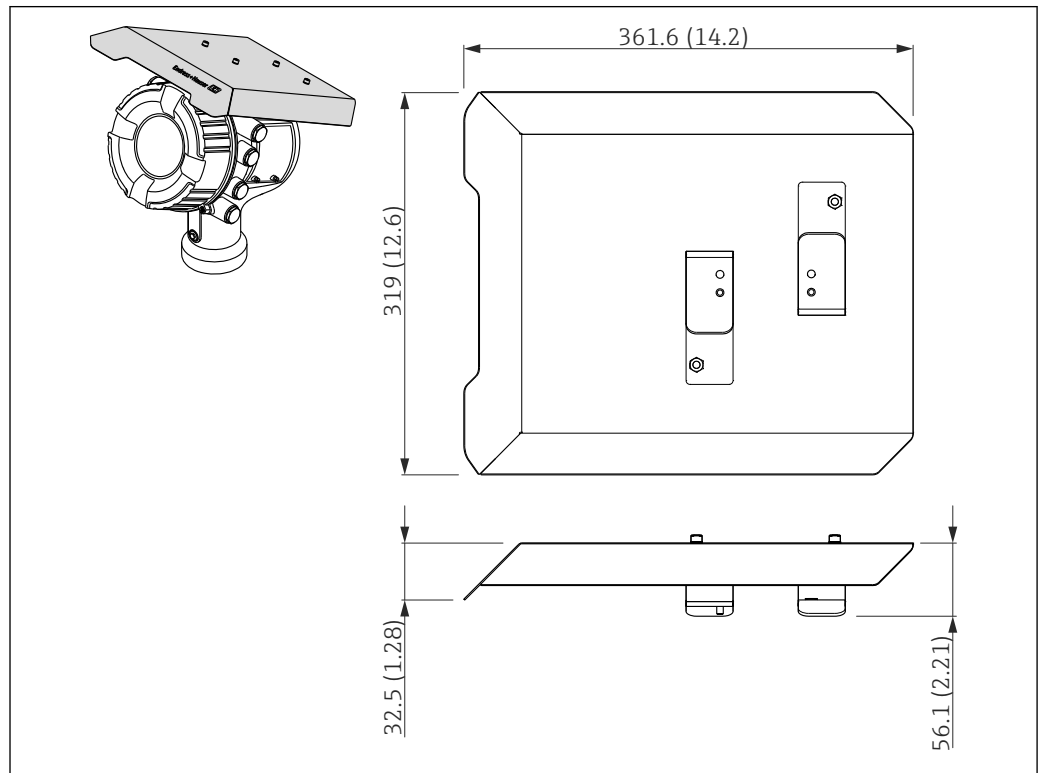

A0028019

17 Weather protection cover; dimensions: mm (in)

Materials

Part	Material
Protection cover and mounting brackets	316L (1.4404)
Screws and washers	A4

i The weather protection cover can be ordered together with the device (ordering feature 620 "Accessory Enclosed", option PA "Weather Protection Cover") or as an accessory.

Communication-specific accessories

Accessory	Description
Commubox FXA195 HART	For intrinsically safe HART communication with FieldCare via the USB interface.  For details refer to Technical Information TI00404F

Accessory	Description
Commubox FXA291	Connects Endress+Hauser field devices with CDI interface (= Endress+Hauser Common Data Interface) to the USB interface of a computer.  For details refer to Technical Information TI00405C

Accessory	Description
WirelessHART Adapter SWA70	Connects field devices to a WirelessHART network. The WirelessHART adapter can be mounted directly at a HART device and is easily integrated into an existing HART network. It ensures safe data transmission and can be operated in parallel with other wireless networks.  For details refer to Operating Instructions BA00061S



Accessory	Description
Fieldgate FXA320	Gateway for remote monitoring of connected 4-20mA measuring devices via web browser.  For details refer to Technical Information TI00025S and Operating Instructions BA00053S

Accessory	Description
Fieldgate FXA520	Gateway for remote diagnosis and parametrization of connected HART measuring devices via web browser.  For details refer to Technical Information TI00025S and Operating Instructions BA00051S

Service-specific accessories

Accessory	Description
FieldCare	Endress+Hauser's FDT-based Plant Asset Management tool. Helps to configure and maintain all field devices of your plant. By supplying status information it also supports the diagnosis of the devices.  For details refer to Operating Instructions BA00027S and BA00059S.

System components

Accessory	Description
RIA15	Compact process display unit with very low voltage drop for universal use to display 4 to 20 mA/HART signals  For details refer to Technical Information TI01043K.
Tankvision ▪ Tank Scanner NXA820 ▪ Data Concentrator NXA821 ▪ Host Link NXA822	Inventory Management System with completely integrated software for operation via standard web browser  For details refer to Technical Information TI00419G.

Documentation

Technical Information (TI) The Technical Information contains all the technical data on the device and provides an overview of the accessories and other products that can be ordered for the device.

Device	Technical Information
Micropilot NMR84	TI01253G

Brief Operating Instructions (KA) The Brief Operating Instructions contain all the essential information from incoming acceptance to initial commissioning.

Device	Brief Operating Instructions
Micropilot NMR84	KA01197G

Operating Instructions (BA) The Operating Instructions contain all the information that is required in various phases of the life cycle of the device: from product identification, incoming acceptance and storage, to mounting, connection, operation and commissioning through to troubleshooting, maintenance and disposal. It also contains a detailed explanation of each individual parameter in the operating menu (except the **Expert** menu). The description is aimed at those who work with the device over the entire life cycle and perform specific configurations.

Device	Operating Instructions
Micropilot NMR84	BA01453G

Description of Device Parameters (GP) The Description of Device Parameters provides a detailed explanation of each individual parameter in the 2nd part of the operating menu: the **Expert** menu. It contains all the device parameters and allows direct access to the parameters by entering a specific code. The description is aimed at those who work with the device over the entire life cycle and perform specific configurations.

Description of Device Parameters (GP) for Micropilot NMR81

Device	Description of Device Parameters
Micropilot NMR84	GP01071G (in preparation)

Safety instructions (XA)

Ordering feature 010 "Approval"	Meaning	XA
BC	<ul style="list-style-type: none"> ▪ ATEX II 1/2 G Ex ia/db IIC T6...T1 Ga/Gb ▪ ATEX II 2 (1) G Ex db [ia Ga] IIC T6...T1 Gb 	XA01410G (in preparation)
FC	FM C/US XP-AIS Cl.I Div.1 Gr.A-D, AEx d[ia] IIC T6...T1	XA01436G (in preparation)
IC	<ul style="list-style-type: none"> ▪ IECEx Ex ia/db IIC T6...T1 Ga/Gb ▪ IECEx Ex db [ia Ga] IIC T6...T1 Gb 	XA01410G (in preparation)

Registered trademarks

FieldCare®

Registered trademark of the Endress+Hauser Process Solutions AG, Reinach, Switzerland

MODBUS®

Registered trademark of the MODBUS-IDA, Hopkinton, MA, USA



www.addresses.endress.com
