



Level



Pressure



Flow



Temperature



Liquid  
Analysis



Registration



Systems  
Components



Services



Solutions

## Technical Information

# Micropilot S FMR540

## Level-Radar

Smart Transmitter for continuous and non-contact precision level measurement. For custody transfer and inventory control applications with NMI and PTB approvals.



### Application

The Micropilot S is used for highly accurate level measurement in storage tanks and can be applied in custody transfer applications. It meets the relevant requirements according to OIML R85 and API 3.1B.

Typical areas of application are:

- The with parabolic antenna is excellently suited for free space applications up to 40 m (131 ft).
- The with horn antenna is suitable for free space applications that disallow the use of a parabolic antenna due to tank/nozzle geometry.

The FMR540 with DN200 (8") parabolic antenna offers high beam focussing of 4° and is therefore ideally suited to applications with nozzles situated close to the tank wall.

The FMR540 with DN100 (4") horn antenna is designed for all small nozzles sizes.

### Your benefits

- Better than 1 mm accuracy.
- National approvals (NMI, PTB) for custody transfer.
- Applicable as stand-alone system or tied into tank gauging systems via the Tank Side Monitor NRF590.
- Cost-effective and simple installation via 4-wire cable with HART and 24V DC intrinsically safe power supply.
- low cost, low weight UNiversal flanges
- top target positioners to compensate any flange inclination
- easy on-site operation via menu-driven alphanumeric display
- easy commissioning, documentation and diagnostics via operating software (ToF Tool - Fieldtool Package or FieldCare)
- HART communication.

## Table of contents

<b>Function and system design</b> .....	<b>3</b>	Climate class .....	19
Measuring principle .....	3	Degree of protection .....	19
Equipment architecture .....	4	Vibration resistance .....	19
Custody transfer applications .....	5	Cleaning of the antenna .....	19
Integrated in tank gauging system .....	6	Electromagnetic compatibility .....	19
		Approvals for custody transfer applications .....	19
<b>Input</b> .....	<b>7</b>	<b>Operating conditions: Process</b> .....	<b>19</b>
Measured variable .....	7	Process temperature range .....	19
Antenna selection for Micropilot S-series .....	7	Process pressure limits .....	19
Measuring range .....	8	Antenna core .....	19
Measuring range depending on sensor type and media group .....	8	Wetted parts .....	19
Measuring conditions .....	9	Optional (top target positioner) .....	19
Operating frequency .....	9	<b>Mechanical construction</b> .....	<b>20</b>
<b>Output</b> .....	<b>10</b>	Design, dimensions .....	20
Output signal .....	10	Type plate / type plate for custody transfer applications .....	22
Signal on alarm .....	10	Endress+Hauser UNI flange .....	23
Linearization .....	10	Weight .....	24
Galvanic isolation .....	10	Material .....	24
<b>Auxiliary energy</b> .....	<b>10</b>	<b>Human interface</b> .....	<b>25</b>
Electrical connection .....	10	Operation concept .....	25
Terminal assignment 4...20 mA with HART .....	11	Display elements .....	25
Load HART .....	12	Operating elements .....	26
Cable entry .....	12	On-site configuration .....	27
Supply voltage .....	12	Remote configuration .....	28
Power consumption .....	12	<b>Certificates and approvals</b> .....	<b>29</b>
Current consumption .....	12	CE approval .....	29
Residual ripple HART .....	12	Ex approval .....	29
Max noise HART .....	12	External standards and guidelines .....	29
Power supply .....	12	Type approvals for custody transfer approvals .....	29
mm accuracy .....	12	RF approvals .....	29
Overvoltage protector .....	12	<b>Ordering information</b> .....	<b>30</b>
<b>Performance characteristics</b> .....	<b>13</b>	Micropilot S FMR540 .....	30
Note .....	13	<b>Ordering structure (continued)</b> .....	<b>31</b>
Reference operating conditions .....	13	<b>Accessories</b> .....	<b>32</b>
Maximum measured error .....	13	Weather protection cover .....	32
Software reliability .....	13	Sensor alignment tool for Target Positioner (alignment device option) only .....	32
Hysteresis .....	13	Commubox FXA191 HART .....	32
Long-term drift .....	13	Commubox FXA195 HART .....	32
Influence of ambiente temperature .....	13	Commubox FXA291 .....	33
Proof of accuracy of custody transfer versions .....	13	ToF Adapter FXA291 .....	33
Non-repeatability .....	13	<b>Documentation</b> .....	<b>34</b>
Resolution .....	13	Fields of activities .....	34
Inventory control versions .....	13	Technical Information .....	34
<b>Operating conditions: Installation</b> .....	<b>14</b>	Operating Instructions .....	34
Installation instructions .....	14	Certificates .....	34
Beam angle .....	15	<b>Patents</b> .....	<b>35</b>
Installation on tank FMR540 .....	16	.....	35
FMR540 with top target positioner .....	18		
Integrated air purge connection .....	18		
<b>Operating conditions: Environment</b> .....	<b>19</b>		
Ambient temperature range .....	19		
Storage temperature .....	19		

## Function and system design

### Measuring principle

The Micropilot is a "downward-looking" measuring system, operating based on the time-of-flight method. It measures the distance from the reference point (process connection) to the product surface. Radar impulses are emitted by an antenna, reflected off the product surface and received again by the radar system.

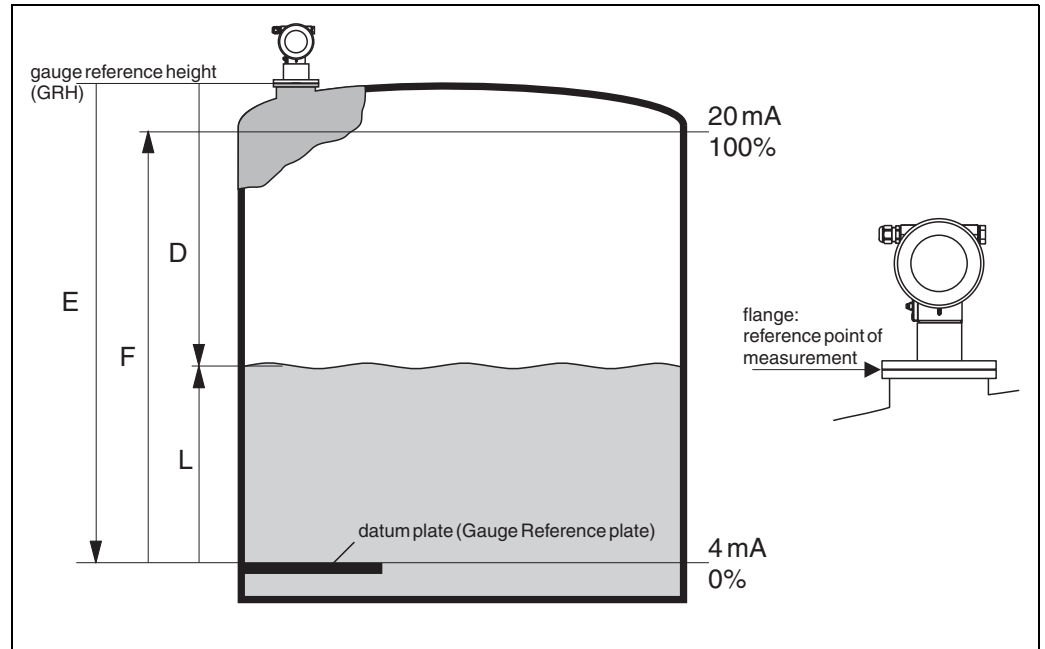

L00-FMR250xx-15-00-00-en-001

### Input

The reflected radar impulses are received by the antenna and transmitted into the electronics. A microprocessor evaluates the signal and identifies the level echo caused by the reflection of the radar impulse at the product surface. The unambiguous signal identification is accomplished by the PulseMaster® software, based on many years of experience with time-of-flight technology.

The distance D to the product surface is proportional to the time of flight  $t$  of the impulse:

$$D = c \cdot t / 2,$$

with  $c$  being the speed of light.

Based on the known empty distance  $E$ , the level  $L$  is calculated:

$$L = E - D$$

Reference point for "E" is the lower surface of the process connection. For highly precise level measurements, it is of crucial importance to have a stable mounting position (GRH) of the radar gauge or to compensate for the effects of tank movements during filling and emptying cycles. This can be done by either using the dip table integrated in the Micropilot S FMR53x / 540 or by using the compensation methods integrated into the Tank Side Monitor NRF590.

The Micropilot is equipped with functions to suppress interference echoes. The user can activate these functions. They ensure that interference echoes (e.g. from edges and weld seams) are not interpreted as level echo.

### Output

The Micropilot is commissioned by entering an empty distance  $E$  (=zero), a full distance  $F$  (=span) and an application parameter. The application parameter automatically adapts the instrument to the measuring conditions. The data points "E" and "F" correspond with 4mA and 20mA for instruments with current output. They correspond with 0 % and 100 % for digital outputs and the display module. For inventory control or custody transfer applications, the measurement should always be transferred via digital communication (HART).

A linearization with max. 32 points, based on a table entered either manually or semi-automatically, can be activated locally or remotely. This function provides a measurement in engineering units and a linear output signal for spheres, horizontal cylindrical tanks and tanks with conical outlet.

**Equipment architecture****Stand-alone**

The instrument provides a 4...20 mA output with HART protocol.

The complete measuring system consists of:

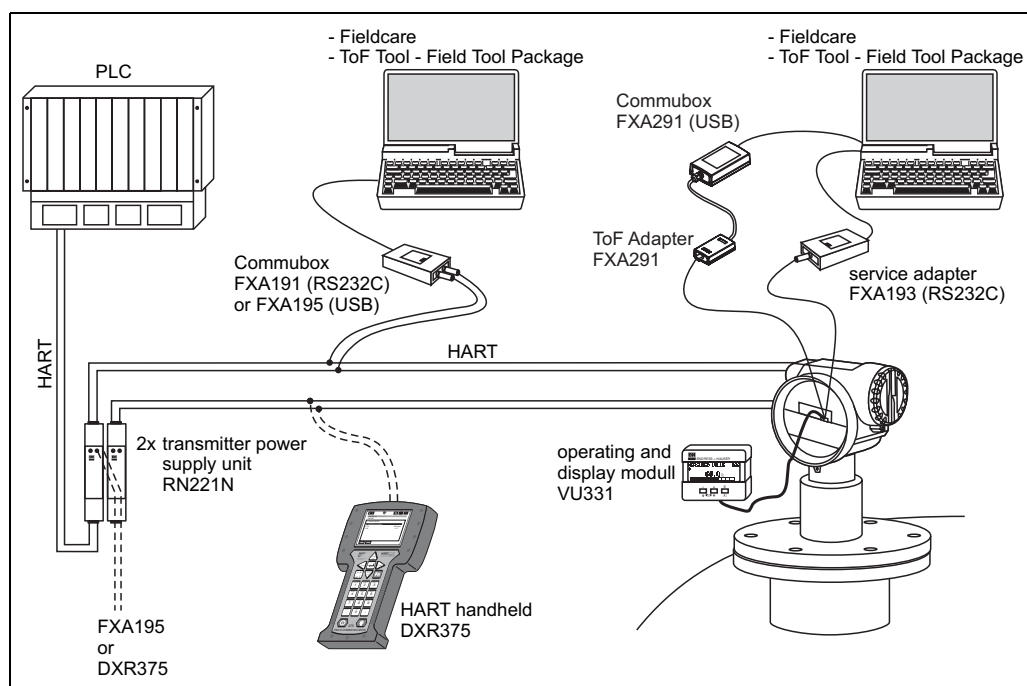

L00-FMR53xxx-14-00-06-es-002

**On-site Configuration**

- with display and operating module VU331,
- with a Personal Computer, FXA193 and the operating software "ToF Tool - FieldTool Package" respectively "FieldCare".

The ToF Tool is a graphical operating software for instruments from Endress+Hauser that operate based on the time-of-flight principle (radar, ultrasonic, guided micro-impulse). It assists with commissioning, securing data, trouble shooting and documentation of the measuring point.

**Remote Configuration**

- with HART handheld DXR375,
- with a Personal Computer, Commubox FXA195 and the operating software "ToF Tool - FieldTool Package" respectively "FieldCare".

**Remote operation**

- With a Personal Computer, NRF590 (Tank Side Monitor) and the inventory management software, e.g. "FuelsManager".

### System integration via Fieldgate

#### Vendor Managed Inventory

By using Fieldgates to interrogate tank or silo levels remotely, suppliers of raw materials can provide their regular customers with information about the current supplies at any time and, for example, account for them in their own production planning. For their part, the Fieldgates monitor the configured level limits and, if required, automatically activate the next supply. The spectrum of options here ranges from a simple purchasing requisition via e-mail through to fully automatic order administration by coupling XML data into the planning systems on both sides.

#### Remote maintenance of measuring equipment

Fieldgates not only transfer the current measured values, they also alert the responsible standby personnel, if required, via e-mail or SMS. In the event of an alarm or also when performing routine checks, service technicians can diagnose and configure connected HART devices remotely. All that is required for this is the corresponding HART operating software (e.g. ToF Tool - FieldTool Package, FieldCare, ...) for the connected device. Fieldgate passes on the information transparently, so that all options for the respective operating software are available remotely. Some on-site service operations can be avoided by using remote diagnosis and remote configuration and all others can at least be better planned and prepared.

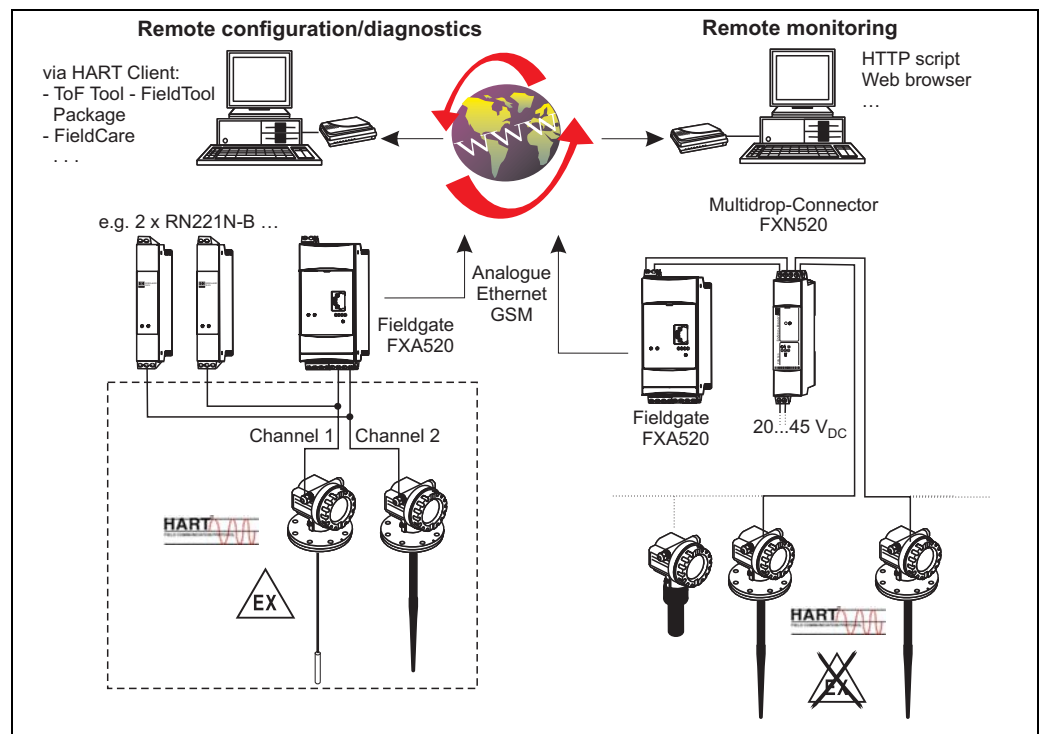

Note!

The number of instruments which can be connected in multidrop mode can be calculated by the "FieldNetCalc" program. A description of this program can be found in Technical Information TI 400F (Multidrop connector FXN520). The program is available from your Endress+Hauser sales organisation or in the internet at: "[www.endress.com](http://www.endress.com) → Download" (Text Search = "Fieldnetcalc").

#### Integration into the Asset Management System

The HART interface allows the integration into the AMS® (Asset Management System) from Emerson.

#### Custody transfer applications

The Micropilot S is suitable for custody transfer and inventory control applications. The on-site testing has to be done in compliance with the applicable regulatory standards. The Micropilot S can be sealed after successful on-site calibration to be protected against any access to the electronics compartment and any changes of software settings. If the Micropilot S is used for custody transfer or inventory control, any temperature influence on the tank shell height can be compensated for using the Tank Side Monitor. In addition, the vertical movement of the gauge reference point due to the hydrostatic tank deformation can be compensated in the Tank Side Monitor. A Tank Side Monitor can provide 24 VDC for a Micropilot S. The Tank Side Monitor can communicate with up to 6 devices via HART Multidrop.

### Integrated in tank gauging system

The Endress+Hauser Tank Side Monitor NRF 590 provides integrated communications for sites with multiple tanks, each with one or more sensors on the tank, such as radar, spot or average temperature, capacitive probe for water detection and/or pressure sensors. Multiple protocols out of the Tank Side Monitor guarantee connectivity to nearly any of the existing industry standard tank gauging protocols. Optional connectivity of analog 4...20 mA sensors, digital I/O and analog output simplify full tank sensor integration. Use of the proven concept of the intrinsically safe HART bus for all on-tank sensors yields extremely low wiring costs, while at the same time providing maximum safety, reliability and data availability.

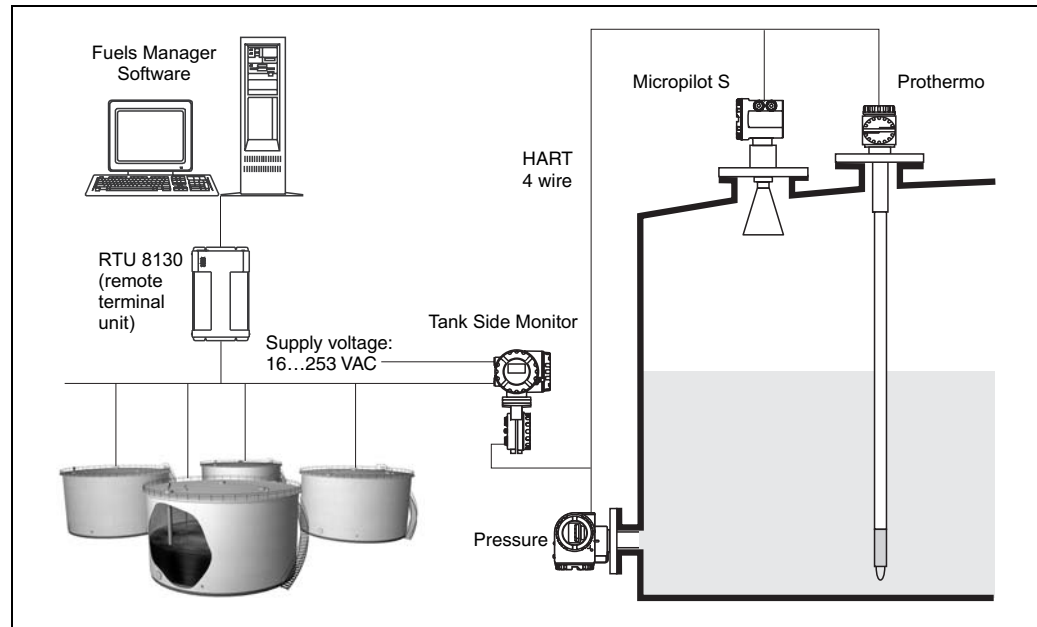

## Input

### Measured variable

The measured variable is the distance between the reference point (GRH, refer to fig. → 3) and a reflective surface (i.e. medium surface).

The level is calculated based on the tank height entered. The level can be converted into other units (volume, mass) by means of a linearization. In order to compensate for non-linear effects like movement of the tank roof, an additional correction table (diptable) can be entered.

### Antenna selection for Micropilot S-series

It is essential for each and every application and installation to select the right antenna type.

The antenna selection depends on the following criteria:

- Type of application (i.e. free space vs. stilling well)
- Installation possibilities (size, location and height of nozzle)
- Properties of the product stored in the tank (radar reflectivity, vapor pressure, temperature, etc.)
- The Micropilot S FMR540 offers 2 radar antennas
  - For stilling well applications, FMR532 should be selected (see TI344F)
  - For measuring mediums with a low reflectivity (i.e. asphalts, bitumen and etc.), FMR533 should be selected (see TI344)

#### Horn antenna

With DN100 (4") horn, this antenna is suitable for most of custody transfer applications up to the measuring distance of 20m/30m (depending on dielectric constant). With the narrow beam angle (8 deg), compared to FMR530, this horn antenna is suitable for closer to tank wall application (→ 15). When installing, it is essential that the horn extends below the nozzle (→ 16).

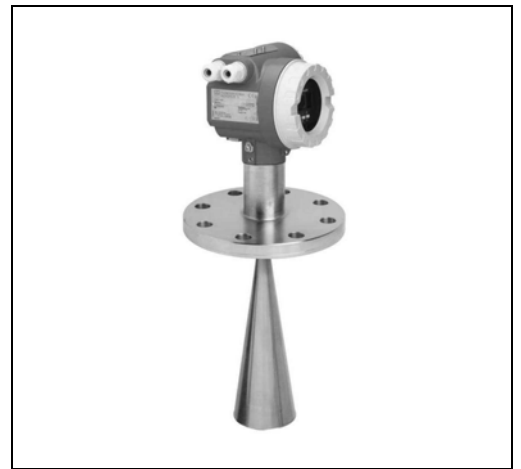

L00-FMR530-10-00-00-yy-001

#### Parabolic antenna

The parabolic antenna offers the smallest beam angle (4 deg) for free space applications. It also covers longest measuring distance of 40m (dielectric constant  $\geq 1.8$ ). It is ideal for applications close to the tank walls, where nozzles are available. When installing, it is ideal that the parabolic antenna is installed in the position where the reflector protrude from the nozzle (→ 18). For measuring mediums with a low reflectivity, such as asphalts and bitumen, FMR533 (please, refer to TI344F) is recommended.



L00-FMR540xx-10-08-06-xx-001

**Measuring range**

The usable measuring range depends on the size of the antenna, the reflectivity of the medium, the mounting location and possible interference reflections.

To achieve an optimised signal strength it is recommended to use an antenna with as large as possible diameter (DN200/8" parabolic antenna).

The following tables describe the groups of media as well as the achievable measuring range as a function of application and media group. If the dielectric constant of a medium is unknown, it is recommended to assume media group B to ensure a reliable measurement.

Table 1:

The following table describes the media groups and the dielectric constant  $\epsilon_r$ .

Media group	DC ( $\epsilon_r$ )	Examples
<b>A</b>	1.4 ... 1.8	non-conducting liquids, e.g. liquefied gas, ... <sup>1)</sup>
<b>B</b>	1.8 ... 4	non-conducting liquids, e.g. benzene, oil, toluene, white products, black products, crudes, bitumen/asphalts, ...
<b>C</b>	4 ... 10	e.g. concentrated acids, organic solvents, esters, aniline, alcohol, acetone, ...
<b>D</b>	> 10	conducting liquids, e.g. aqueous solutions, dilute acids and alkalis

1) Treat Ammonia  $\text{NH}_3$  as a medium of group A.

**Measuring range depending on sensor type and media group**

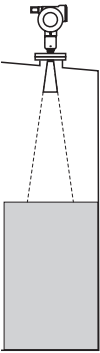
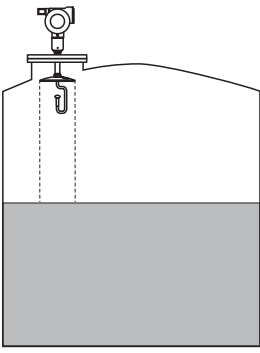
Media group		Horn antenna without sensor extension	Parabolic antenna without sensor extension
			
		Measuring range	Measuring range
<b>A</b>	DC ( $\epsilon_r$ ) = 1.4 ... 1.8	–	–
<b>B</b>	DC ( $\epsilon_r$ ) = 1.8 ... 4	0.6 ... 20 m	0.8 ... 40 m
<b>C</b>	DC ( $\epsilon_r$ ) = 4...10	0.6 ... 30 m	0.8 ... 40 m
<b>D</b>	DC ( $\epsilon_r$ ) > 10	0.6 ... 30 m	0.8 ... 40 m
Max. measuring range with custody transfer approval		NMi: 20 m / 65 ft PTB: 20 m / 65 ft	NMi: 25 m / 82 ft PTB: 30 m / 98 ft

Note!

For stilling well applications Micropilot S FMR532 is recommended (see Technical Information TI344F).



**Measuring conditions**

- The measuring range begins, where the beam hits the tank bottom. Particularly with dish bottoms or conical outlets the level cannot be detected below this point.
- In case of media with a low dielectric constant (groups A and B), the tank bottom can be visible through the medium at low levels (low height **C**). Reduced accuracy has to be expected in this range. If this is not acceptable, we recommend positioning the zero point at a distance **C** (see Fig.) above the tank bottom in these applications.
- In principle it is possible to measure up to the tip of the antenna with FMR540. However, due to considerations regarding corrosion and build-up, the end of the measuring range should not be chosen any closer than **A** (see Fig.).
- **B** requests the smallest possible measuring range (see fig.).
- Tank diameter and height should be at least dimensioned such that a reflection of the radar signal on both sides of the tank can be avoided.
- Depending on its consistence, foam can either absorb microwaves or reflect them off the foam surface. Measurement is possible under certain conditions.

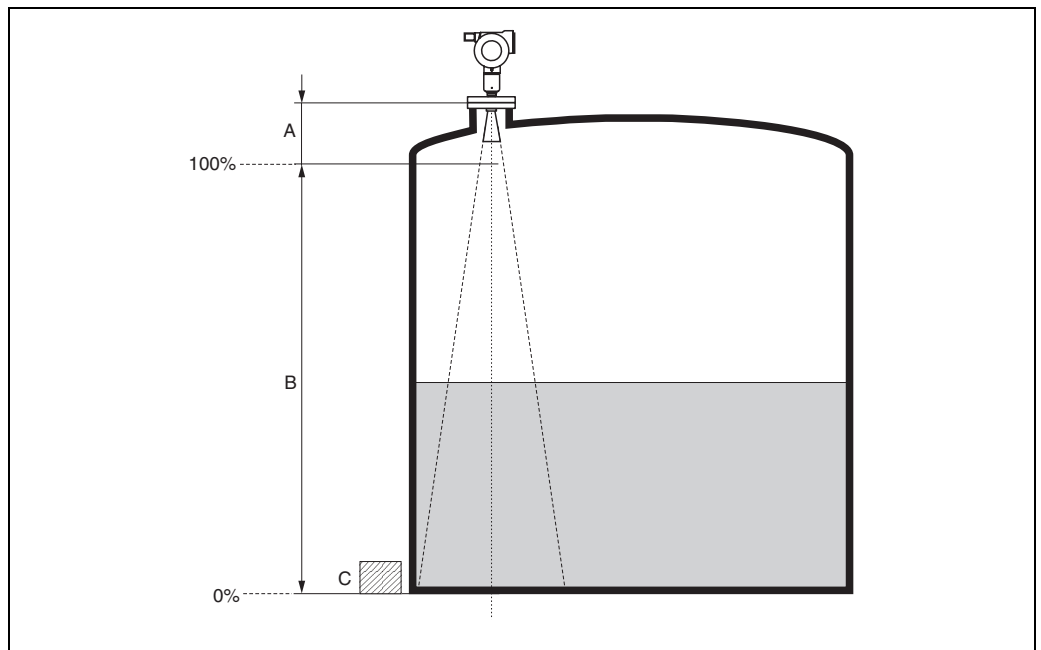

100-FMR54xxx-17-00-00-yy-009

	A [m (inch)]	B [m (inch)]	C [mm (inch)]
<b>FMR540 (Horn Antenna without extension)</b>	0.6 (23.6)	> 0.5 (> 20)	> 300 (> 12)
<b>FMR540 (parabolic Antenna without extension)</b>	0.8 (31.5)	> 0.5 (> 20)	> 300 (> 12)

**Behaviour if measuring range is exceeded**

The behaviour in case of the measuring range being exceeded can be freely set: the default setting is a current of 22 mA and the generation of a digital warning (E651).

**Operating frequency**

- FMR540: 26 GHz ultra wideband system

## Output

<b>Output signal</b>	<ul style="list-style-type: none"> <li>■ 4...20 mA with HART protocol (e.g. for multidrop connection to the Tank Side Monitor NRF590); this version can be operated via the PC operating software ToF Tool and FieldCare. The instrument supports both point-to-point and multidrop operation.</li> </ul>
<b>Signal on alarm</b>	<p>Error information can be accessed via the following interfaces:</p> <ul style="list-style-type: none"> <li>■ Local display: <ul style="list-style-type: none"> <li>– Error symbol</li> <li>– Plain text display</li> <li>– LED's: red LED continuously on = alarm, red LED flashes = warning</li> </ul> </li> <li>■ Current output</li> <li>■ Digital interface</li> </ul>
<b>Linearization</b>	<p>The linearization function of the Micropilot S allows the conversion of the measured value into any unit of length or volume. Linearization tables for calculating the volume in cylindrical tanks are pre-programmed. Other tables of up to 32 value pairs can be entered manually or semi-automatically.</p>
<b>Galvanic isolation</b>	<p>500 V towards ground. 500 V between power supply and signal.</p>

## Auxiliary energy

<b>Electrical connection</b>	<p><b>Terminal compartment</b></p> <ul style="list-style-type: none"> <li>■ Aluminium housing T12 with separate terminal compartment for: <ul style="list-style-type: none"> <li>– standard,</li> <li>– EEx ia (with overvoltage protection),</li> </ul> </li> </ul> <p>The electronics and current output are galvanically isolated from the antenna circuit.</p>
------------------------------	--

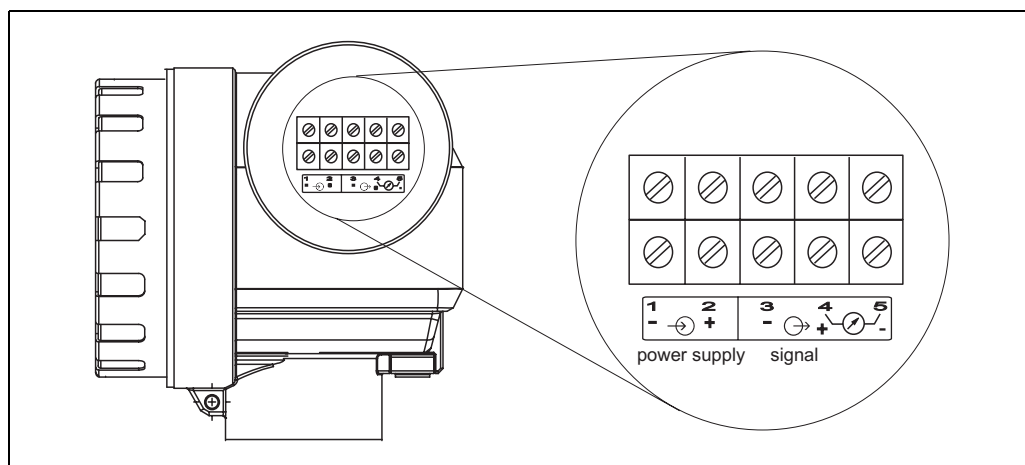

L00-FMR53xxx-04-00-00-en-001

**Terminal assignment 4...20 mA with HART**

The 4-wire cable is connected to the screw terminals (wire diameter 0.5...2.5 mm) in the terminal compartment. Use 4-wire twisted pair cable with screen for the connection. Protective circuitry against reverse polarity, RFI, and over-voltage peaks is built into the device (refer to TI241F »basics for EMC-tests«). Refer to TI374F for connection to the Tank Side Monitor NRF590.

**Connection to Tank Side Monitor NRF590**

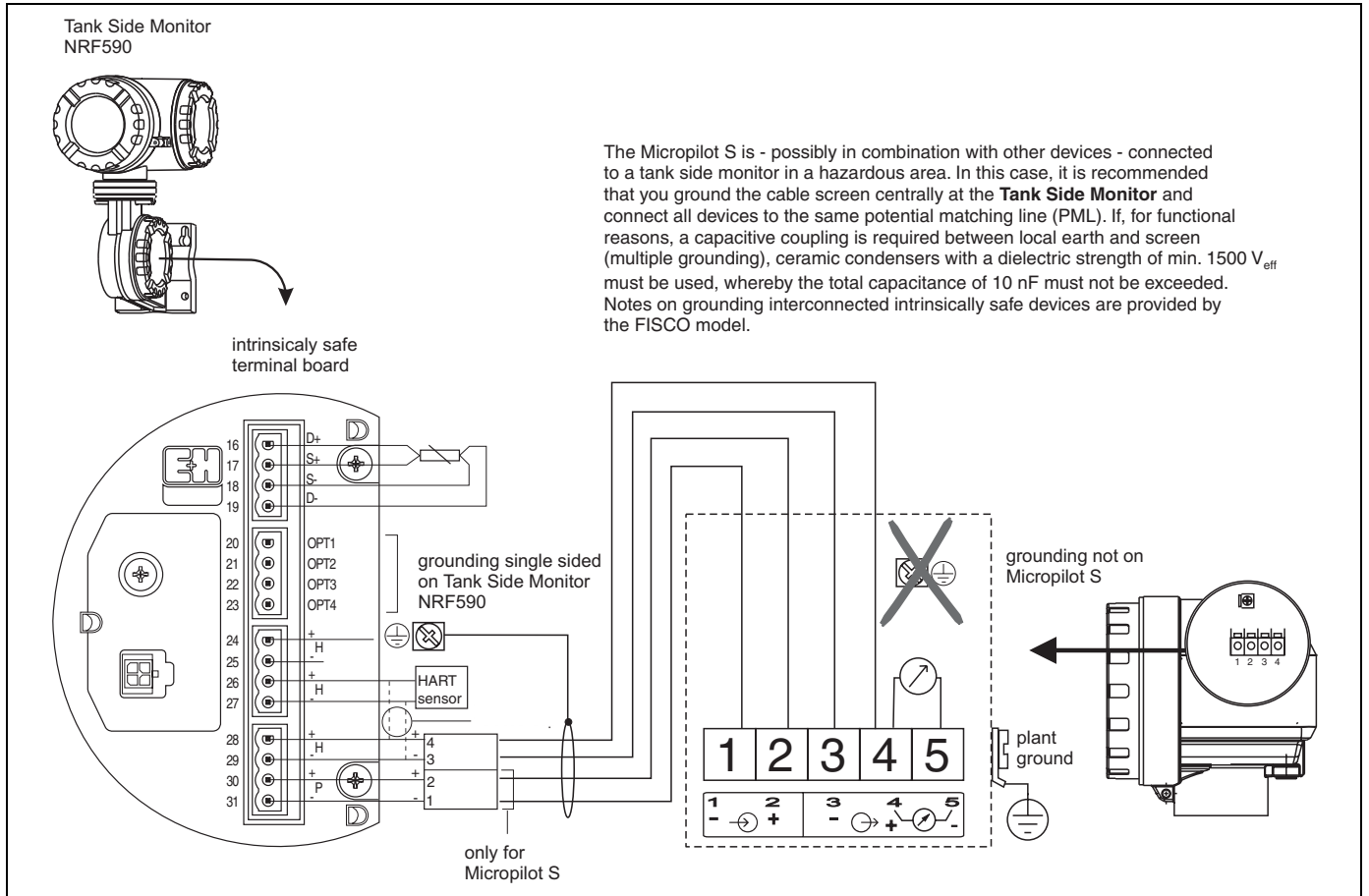

**Connection as a stand alone device**

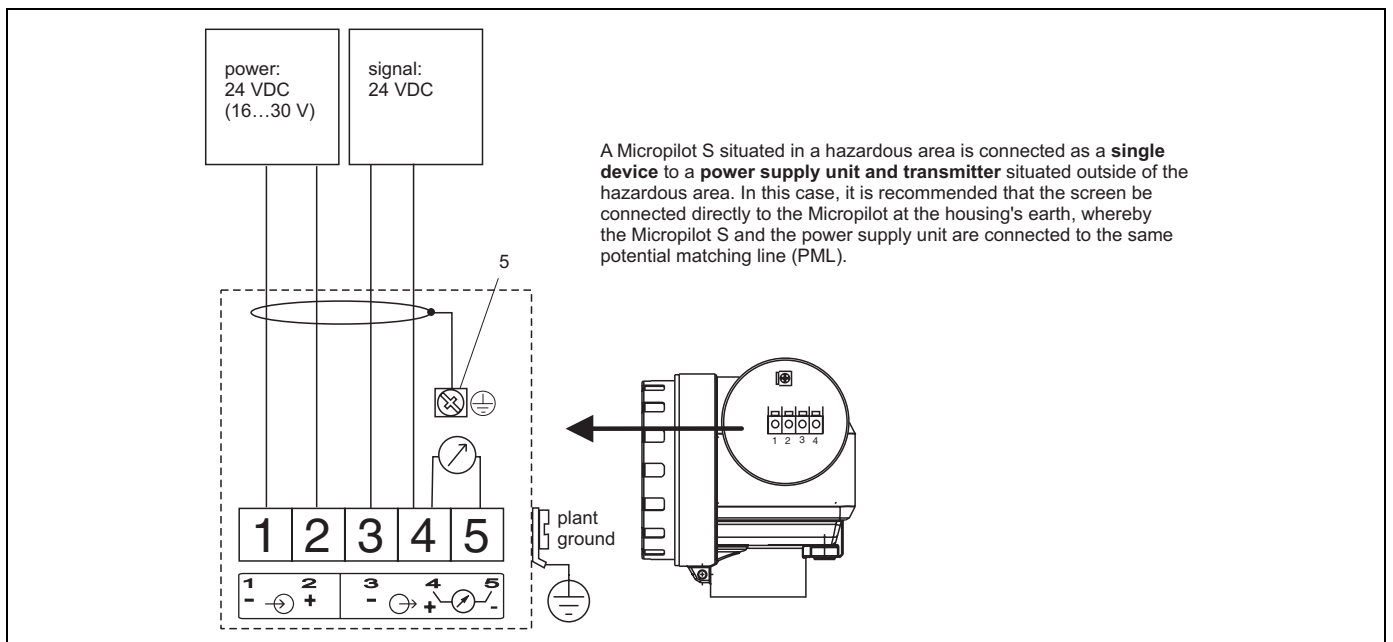

**Load HART** Minimum load for HART communication: 250  $\Omega$

**Cable entry** Cable gland: M20x1.5  
Cable entry: G 1/2, 1/2 NPT, M20 (thread)

**Supply voltage** DC voltage: 16...36 V

Communication		Terminal voltage	minimal	maximal
Power supply	standard	U (20 mA) =	16 V	36 V
	Ex	U (20 mA) =	16 V	30 V
Signal	Ex	U (4 mA) =	11.5 V	30 V
		U (20 mA) =	11.5 V	30 V

**Power consumption** Max. 400 mW at 16 V, max. 600 mW at 24 V, max. 750 mW at 30 V.

**Current consumption** Max. 25 mA (55 mA inrush current).

**Residual ripple HART** 47...125 Hz:  $U_{pp} = 200$  mV

**Max noise HART** 500 Hz...10 kHz :  $U_{eff} = 19$  mV (at 500  $\Omega$ )

**Power supply** For stand alone operation recommended via two Endress+Hauser RN221N.

**mm accuracy** For measurements with mm accuracy the measured variable must be transmitted using HART protocol to ensure the necessary resolution.

**Overvoltage protector**

- The level transmitter Micropilot S is equipped with an internal overvoltage protector (600 Vrms surge arrester) according to DIN EN 60079-14 or IEC 60060-1 (impulse current test 8/20  $\mu$ s,  $I = 10$  kA, 10 pulses). Additionally, the instrument is protected by a galvanic insulation of 500 Vrms between the power supply and the (HART) current output. Connect the metallic housing of the Micropilot S to the tank wall or screen directly with an electrically conductive lead to ensure reliable potential matching.
- Installation with additional overvoltage protector HAW262Z/HAW56xZ (see XA081F-A "Safety instructions for electrical apparatus certified for use in explosion-hazardous areas").
  - Connect the external overvoltage protector and the Micropilot S transmitter to the local potential matching system.
  - Potentials shall be equalised both inside and outside the explosion hazardous area.
  - The cable connecting the overvoltage protector and the Micropilot S transmitter shall not exceed 1 m in length;
  - The cable shall be protected e.g. routed in an armoured hose.

## Performance characteristics

<b>Note</b>	Performance characteristics for instruments that can be calibrated for inventory control and custody transfer applications are according to weight & measure standards in compliance with OIML R85. General operating / environmental conditions see → <a href="#">19</a> .
<b>Reference operating conditions</b>	<p><b>According to OIML R85:</b></p> <ul style="list-style-type: none"> <li>■ Temperature = -25...+55 °C (-13...+131 °F)</li> <li>■ Atmospheric pressure</li> <li>■ Relative humidity (air) = 60 % ±15%</li> <li>■ Medium properties: e.g. medium with good reflectivity and calm surface.</li> <li>■ Tank diameter: signal beam hits the tank wall only at one side.</li> <li>■ No major interference reflections inside the signal beam.</li> </ul>
<b>Maximum measured error</b>	Absolute accuracy: better than ±1 mm (better than 1/16")
<b>Software reliability</b>	<p>The software used in the radar instruments FMR540 fulfills the requirements of OIML R85. This particularly includes:</p> <ul style="list-style-type: none"> <li>■ cyclical test of data consistency</li> <li>■ non-volatile memory</li> <li>■ segmented data storage</li> </ul> <p>The radar instruments Micropilot S continuously monitor the compliance with accuracy requirements for custody transfer measurements according to OIML R85. If the accuracy cannot be maintained, a specific alarm is generated on the local display and via the digital communication (see → <a href="#">25</a>).</p>
<b>Hysteresis</b>	0.1 mm
<b>Long-term drift</b>	The long-term drift is within the specified accuracy.
<b>Influence of ambient temperature</b>	<p>Current output (additional error, in reference to the span of 16 mA):</p> <ul style="list-style-type: none"> <li>■ <b>Zero point (4 mA)</b> average <math>T_K</math>: 0,025 %/10 K, max. 0,291 % over the entire temperature range -40 °C...+80 °C</li> <li>■ <b>Span (20 mA)</b> average <math>T_K</math>: 0,07 %/10 K, max. 0,824 % over the entire temperature range -40 °C...+80 °C</li> </ul>
<b>Proof of accuracy of custody transfer versions</b>	<p>The accuracy of each Micropilot S is established through a calibration certificate that records the absolute and relative error at 10 equidistant points during the final test. A Laser Interferometer (Jenaer Messtechnik ZLM 500) with an absolute accuracy of 0.1 mm is used as a reference for the free space measurements with FMR540.</p> <p>Additional initial factory verifications for custody applications are available on demand for all radar instruments FMR540.</p>
<b>Non-repeatability</b>	0.1 mm (1/64")
<b>Resolution</b>	Digital 0.1 mm / analogue (4...20 mA): 0.03 % of measuring range
<b>Inventory control versions</b>	All device types can be delivered as "Inventory Control Versions" with a reduced accuracy of ± 3mm (under reference conditions). To these versions, the calibration certificate or custody transfer type approval is NOT attached. The "Inventory Control Versions" can be selected by choosing the option "R" - reduced accuracy" in the order code option »Custody transfer approvals« → <a href="#">31</a> .

## Operating conditions: Installation

### Installation instructions

#### Orientation

- Recommended distance (1) from tank wall to the center of the nozzle: minimum as specified in Table on → 15 (beam angle / distance to wall).
- Not in the centre (3), interference can cause signal loss.
- Not above the fill stream (4).
- It is recommended to use a weather protection cover (2) in order to protect the transmitter from direct sun or rain. Assembly and disassembly is simply done by means of a tension clamp (see Accessories on → 32).

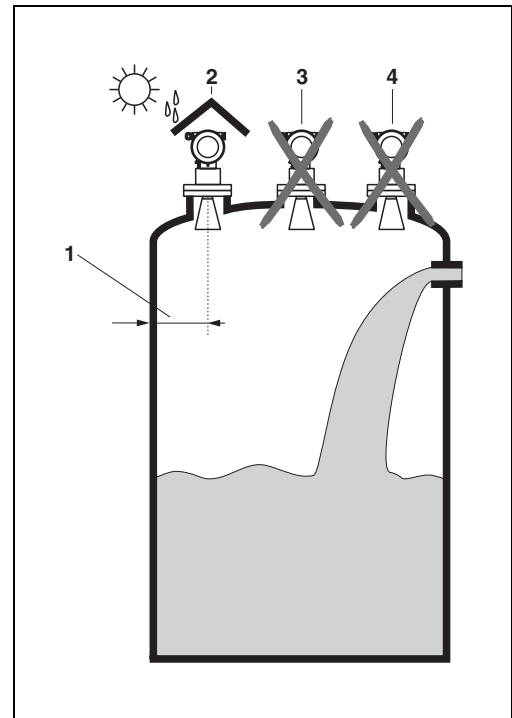

L00-FMR54xxx-17-00-00-yy-012

#### Tank installations

- Avoid any installations (1), like limit switches, temperature sensors, etc., inside the signal beam (refer to beam angle → 15).
- It is essential that HiHi alarm is below the blocking distance (BD) and the safety distance (SD).
- Symmetrical installations (2), e.g. vacuum rings, heating coils, baffles, etc., can also interfere with the measurement.

#### Optimisation options

- Antenna size: the bigger the antenna, the smaller the beam angle, the less interference echoes.
- Mapping: the measurement can be optimized by means of electronic suppression of interference echoes.
- Antenna alignment: refer to "optimum mounting position" (→ 16).
- Stilling well: a stilling well can always be used to avoid interference. The FMR532 with planar antenna is recommended for stilling wells with a diameter DN150 (6") and larger.
- Metallic screens (3) mounted at a slope spread the radar signals and can, therefore, reduce interference echoes.

Please contact Endress+Hauser for further information.

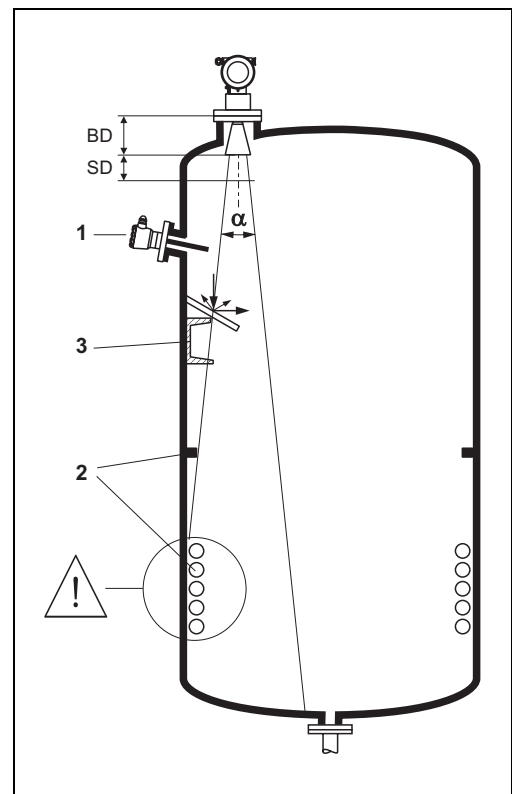

L00-FMR54xxx-17-00-00-yy-013

**Beam angle**

The beam angle is defined as the angle  $\alpha$  where the energy density of the radar waves reaches half the value of the maximum energy density (3dB-width). Microwaves are also emitted outside the signal beam and can be reflected off interfering installations. Beam diameter **W** is a function of antenna type (beam angle  $\alpha$ ) and measuring distance **D**. The distance between the tank wall and the center of the sensor should be greater than  $W/2$ . It is strongly recommended to avoid any mechanical obstacles within the highlighted area.

	Horn antenna
Antenna size	100 mm / 4"
Beam angle ( $\alpha$ )	8°

Measuring distance (D)	Beamwidth diameter (W)	Recommended distance to wall (W/2)
5 m / 16 ft	0.70 m / 2.24 ft	0.35 m
10 m / 32 ft	1.40 m / 4.48 ft	0.70 m
15 m / 49 ft	2.10 m / 6.85 ft	1.05 m
20 m / 65 ft	2.80 m / 9.09 ft	1.40 m
25 m / 82ft	3.50 m / 11.48 ft	1.75 m
30 m / 98 ft	4.20 m / 13.71 ft	2.10 m

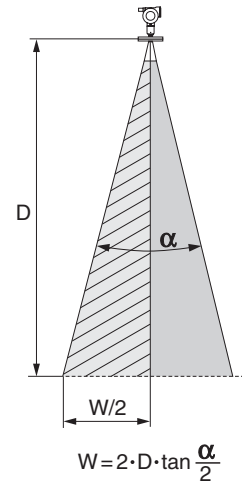

L00-FMR54xxx-14-00-00-xx-003

	Parabolic antenna
Antenna size	200 mm / 8"
Beam angle ( $\alpha$ )	4°

Measuring distance (D)	Beamwidth diameter (W)	Recommended distance to wall (W/2)
5 m / 16 ft	0.35 m / 1.12 ft	0.18 m
10 m / 32 ft	0.70 m / 2.23 ft	0.35 m
15 m / 49 ft	1.05 m / 3.42 ft	0.53 m
20 m / 65 ft	1.40 m / 4.54 ft	0.70 m
25 m / 82ft	1.7 m / 5.58 ft	0.85 m
30 m / 98 ft	2.10 m / 6.84 ft	1.05 m
35 m / 115 ft	2.45 m / 8.04 ft	1.23 m
40 m / 131 ft	2.80 m / 9.15 ft	1.40 m

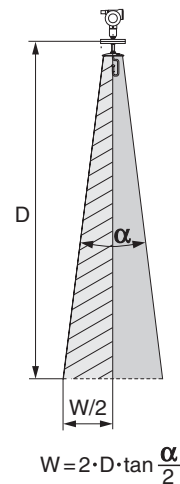

L00-FMR54xxx-14-00-00-xx-004

Installation on tank FMR540

Optimum mounting position

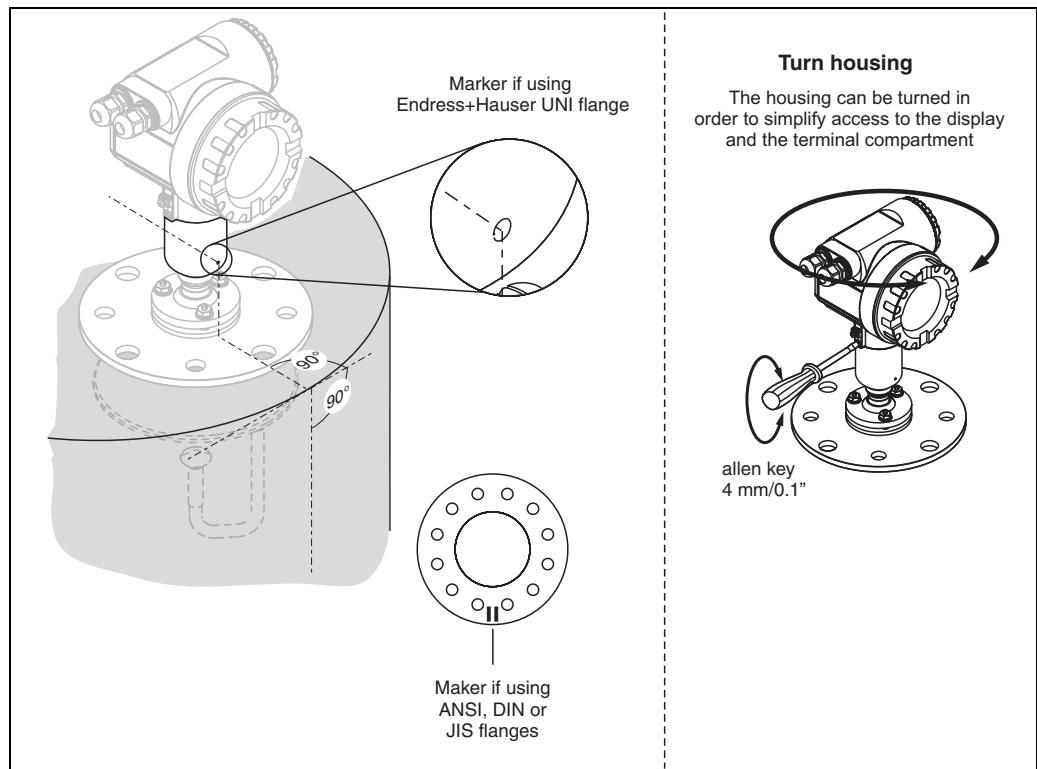

L00-FMR54xxx-17-00-00-es-010

Standard installation FMR540 with horn antenna

- Observe installation instructions on Page 14.
- Marker is aligned towards tank wall.
- The marker is always exactly in the middle between two bolt-holes in the flange.
- After mounting, the housing can be turned 350° in order to simplify access to the display and the terminal compartment.
- Adjust vertical sensor alignment in case the flange is not parallel to the face of medium surface.
- The horn antenna should protrude from the nozzle. If necessary, choose version with antenna extension (→ 21).

Note!

Please contact Endress+Hauser for application with higher nozzle.

- The horn antenna should be installed with 1 degree inclination towards the tank center. To avoid interference reflections or for optimum alignment within the tank, the FMR540 with optional top target positioner can be swiveled by 15° in all directions. For more informations please see instructions in KA274F/00. Please contact Endress+Hauser Service Organisation for commissioning.

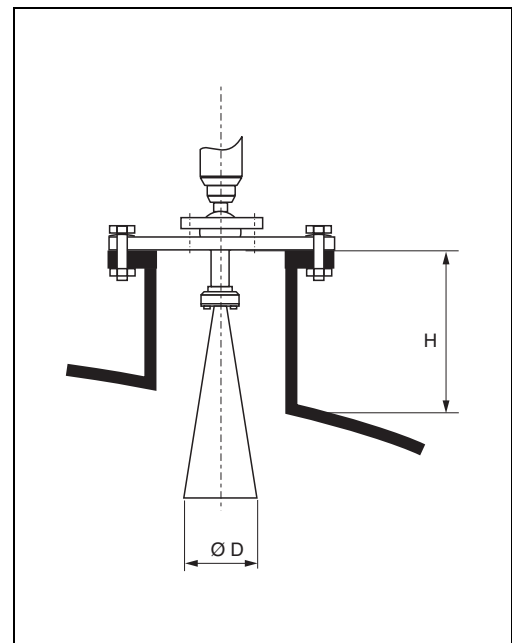

L00-FMR250xxx-17-00-00-es-004

Antenna size	100 mm / 4"
D [mm / inch]	95 / 3.7
H [mm / inch] (without antenna extension)	< 430 / < 19.2



**Standard installation FMR540 with parabolic antenna**

- Observe installation instructions on Page 14.
- Marker is aligned towards tank wall.
- The marker is always exactly in the middle between two bolt-holes in the flange.
- After mounting, the housing can be turned 350° in order to simplify access to the display and the terminal compartment.
- Ideally the parabolic antenna should protrude from the nozzle (1). If necessary, choose version with antenna extension (→ 21). Particularly when using the top target positioner, please ensure that the parabolic reflector is protruding from the nozzle/roof so as not to inhibit alignment.

Note!

For application with higher nozzle install parabolic antenna completely in the nozzle (2), including RF-wave guide (3).

- The parabolic antenna should be installed vertically.
- To avoid interference reflections or for optimum alignment within the tank, the FMR540 with optional top target positioner can be swiveled by 15° in all directions. For more informations please see instructions in KA274F/00. Please, contact Endress+Hauser Service organization for commissioning.

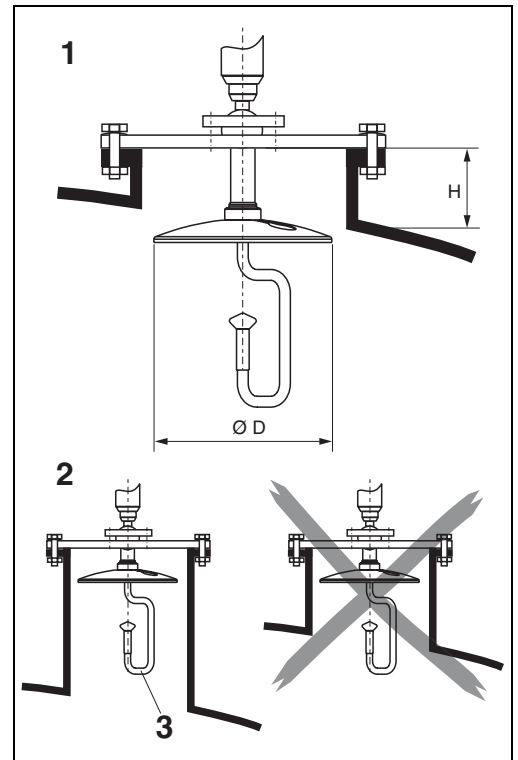

L00-FMR54xxx-17-00-00-en-004

<b>Antenna size</b>	200 mm / 8"
<b>D [mm / inch]</b>	197 / 7.75
<b>H [mm / inch] (without antenna extension)</b>	< 50 / < 1.96

### FMR540 with top target positioner

#### Optimum mounting position

Micropilot S should be installed vertically towards the Liquid surface for best measuring performance of  $\pm 1$  mm. Using top target positioner it is possible to tilt the antenna axis by up to  $15^\circ$  in all directions. The top target positioner is used for the optimum alignment of the radar beam to the liquid surface.

The Sensor should be positioned vertical to the liquid surface in inclination of  $0^\circ$  for Parabolic Antenna and  $1^\circ$  for Horn Antenna.

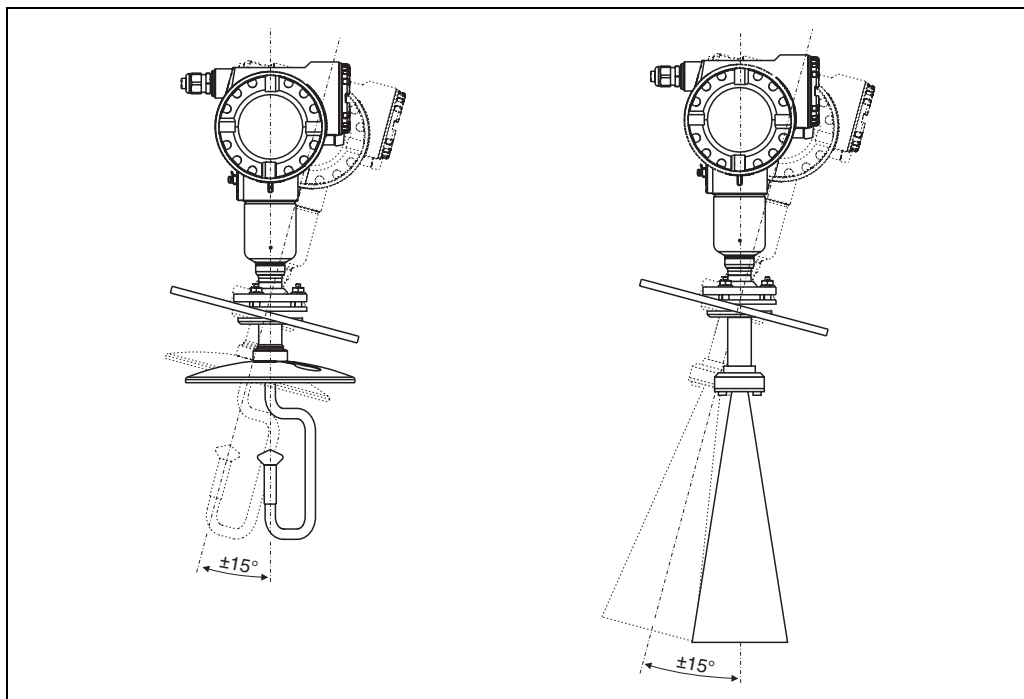

L00-FMR54xxxx-17-00-00-es-006

Align antenna axis:

1. Loosen screws.
2. Align antenna axis (here this is possible up to max.  $\pm 15^\circ$  in all directions).
3. Tighten screws.

For more informations please see instructions in KA274F/00.

In case of custody Application, the screws must be locked with wires.

### Integrated air purge connection

In some applications, the integrated air purge connection can prevent clogging of the antenna.

- Permanent operation:  
recommended pressure range of the purge air:  
1.2...1.5 bar abs.
- Pulsed operation:  
max. pressure of purge air: 6 bar abs.

#### Caution!

Make sure to use dry purge air.

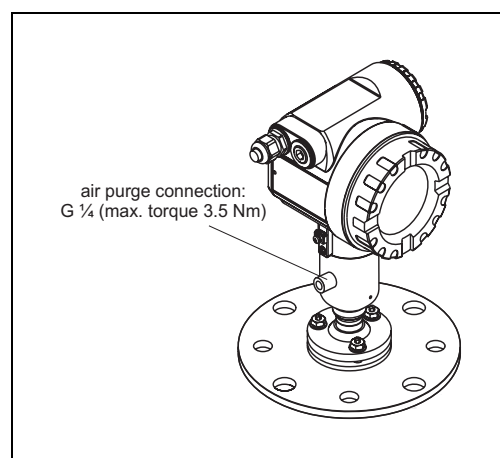

L00-FMR54xxxx-17-00-00-es-007

## Operating conditions: Environment

<b>Ambient temperature range</b>	Ambient temperature for the transmitter: <ul style="list-style-type: none"> <li>■ Standard: -40 °C ... +80 °C (-40 °F...+176 °F)</li> <li>■ For calibration to regulatory standards: -25 °C ... +60 °C (-30 °F...+140 °F)</li> </ul> With $T_u < -20$ °C and $T_u > +60$ °C the operability of the LC-display is reduced. A weather protection cover should be used for outdoor operation if the instrument is exposed to direct sunlight.
<b>Storage temperature</b>	-40 °C ... +80 °C (-40 °F...+176 °F)
<b>Climate class</b>	DIN EN 60068-2-38 (test Z/AD)
<b>Degree of protection</b>	<ul style="list-style-type: none"> <li>■ Transmitter: IP 68, NEMA 6P. With open housing: IP20, NEMA 1.</li> <li>■ Antenna: IP 68 (NEMA 6P)</li> </ul>
<b>Vibration resistance</b>	DIN EN 60068-2-64 / IEC 68-2-64: 20...2000 Hz, 1 (m/s <sup>2</sup> )/Hz
<b>Cleaning of the antenna</b>	The antenna can get contaminated, depending on the application. The emission and reception of microwaves can thus eventually be hindered. The degree of contamination leading to an error depends on the medium and the reflectivity, mainly determined by the dielectric constant $\epsilon_r$ . If the medium tends to cause contamination and deposits, cleaning on a regular basis is recommended. Care has to be taken not to damage the antenna in the process of a mechanical or hose-down cleaning. The material compatibility has to be considered if cleaning agents are used! The maximum permitted temperature at the flange should not be exceeded. .
<b>Electromagnetic compatibility</b>	<ul style="list-style-type: none"> <li>■ Interference Emission to EN 61326, Electrical Equipment Class B</li> <li>■ Interference Immunity to EN 61326, Annex A (Industrial) and NAMUR Recommendation NE 21 (EMC)</li> <li>■ A standard installation cable is sufficient if only the analogue signal is used. Use a screened cable when working with a superimposed communications signal (HART).</li> </ul>
<b>Approvals for custody transfer applications</b>	All aspects of OIML R85 are fulfilled.

## Operating conditions: Process

<b>Process temperature range</b>	FKM Viton GLT, -40 °C...+200 °C (-40 °F...+392 °F)
<b>Process pressure limits</b>	<ul style="list-style-type: none"> <li>■ Parabolic Antenna -1...6 bar (-14.5...87 psi)</li> <li>■ Horn Antenna -1...16 bar (-14.5 psi...232 psi)</li> <li>■ With Endress+Hauser UNI flange -1...1bar (-14.5 psi...14.5 psi)</li> </ul>
<b>Antenna core</b>	<ul style="list-style-type: none"> <li>■ Parabolic Antenna: Teflon (PTFE)</li> <li>■ Horn Antenna: PEEK</li> </ul>
<b>Wetted parts</b>	<ul style="list-style-type: none"> <li>■ Parabolic Antenna: Teflon (PTFE), seal and 316L/1.4404/1.4435</li> <li>■ Horn Antenna: PEEK, seal and 316L/1.4404/1.4435</li> </ul>
<b>Optional (top target positioner)</b>	± 15° inclination seal: FKM Viton GLT

## Mechanical construction

### Design, dimensions

### Housing dimensions

Dimensions for process connection and type of antenna see Page 21.

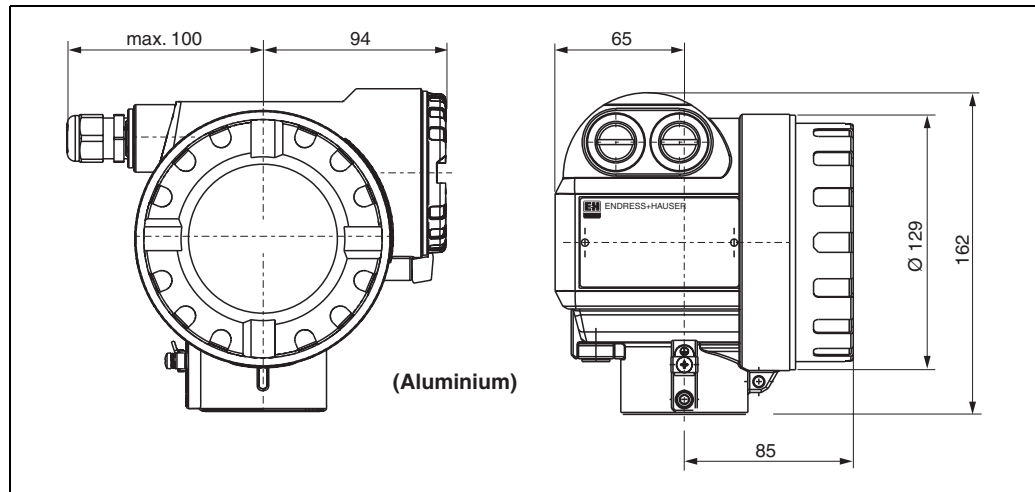

**Micropilot M FMR540 - process connection, type of antenna**

Housing dimensions → 20.

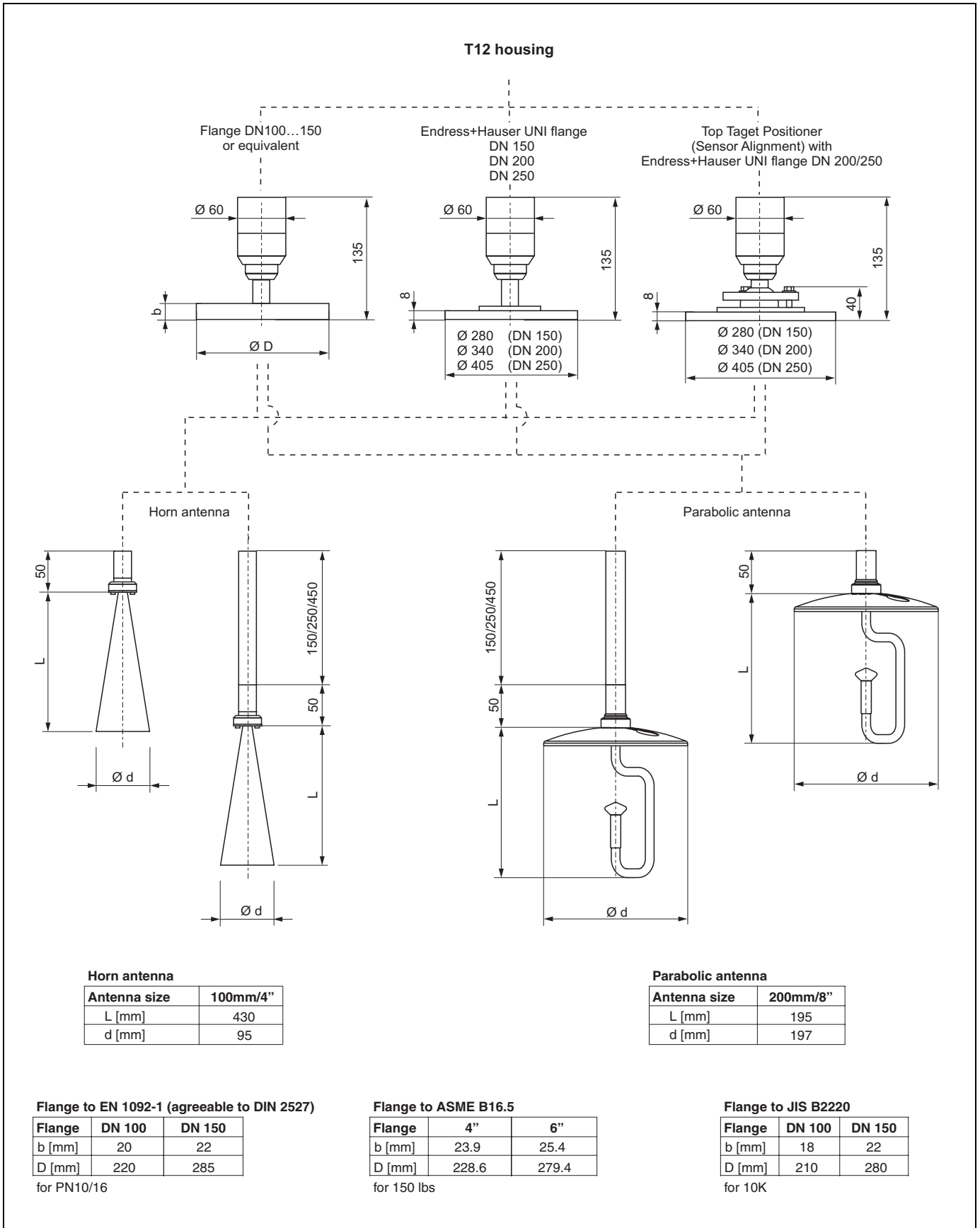

**Type plate / type plate for custody transfer applications**

In addition to the standard type plate, the instrument features a type plate for custody transfer applications with the following statements:

- manufacturer
- instrument type
- label for custody transfer approval
  - PTB : „Z“ with approval number and issuing agency, the 4-digit approval number is shown in the upper part of the „Z“, the lower part shows year and month of type approval.
  - NMi : field for 5-digit approval number
- year of manufacturing
- space for imprinted tank identification number
- statement of measuring range suitable for custody transfer approval including unit
- statement of ambient temperature range suitable for calibration to regulatory standards

The following statements are also required for calibration to regulatory standards. They are listed on the standard type plate and are not repeated here:

- date of manufacturing
- tester

The type plate for calibration to regulatory standards can be sealed. It is mounted with screws, therefore also available as a spare part. The „stamping“ of the electronic compartment is achieved with the custody locking switch (compare figure on → 25) and does not require any additional stamping location. NMI and PTB type plate for custody transfer approval refer to illustration:

**NMI type plate (example)**

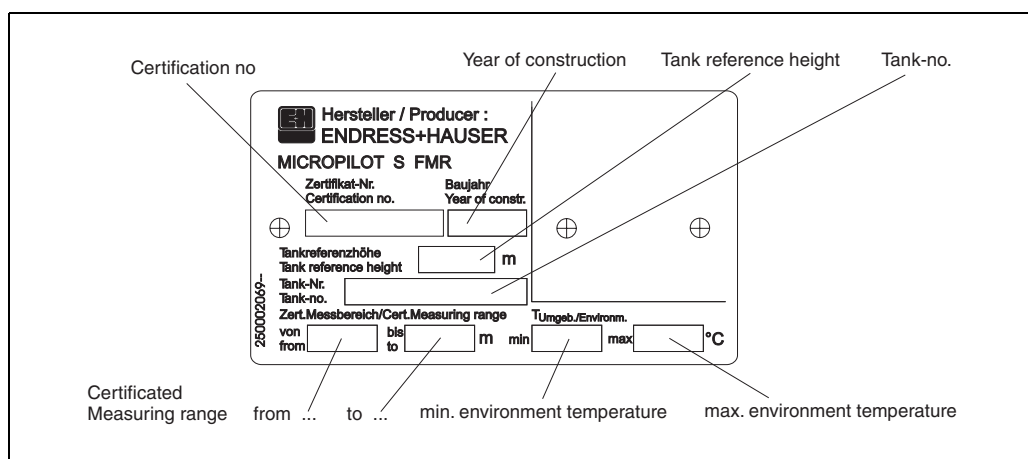

100-FMR540xx-18-00-00-en-001

**PTB type plate (example)**

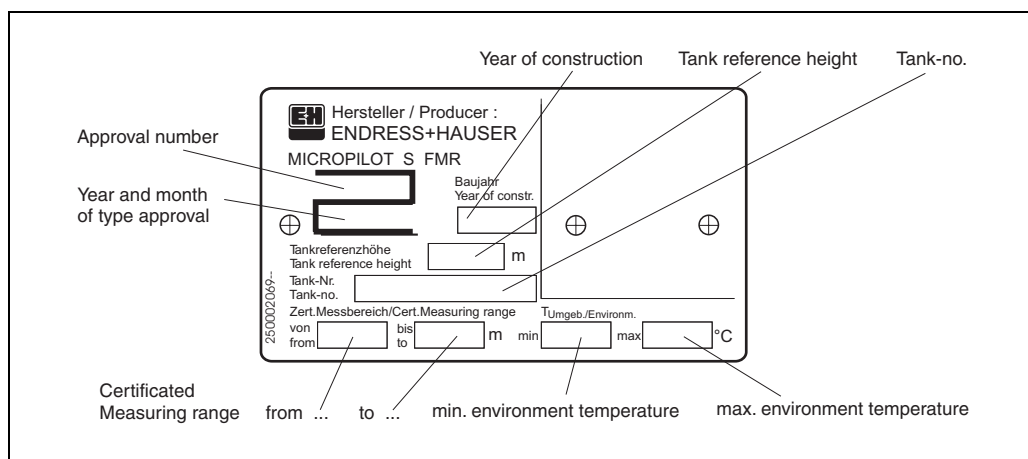

100-FMR540xx-18-00-00-en-002

**Endress+Hauser UNI flange**

**Installation hints**

The number of bolts has sometimes been reduced. The bolt-holes have been enlarged for adaption of dimensions, therefore, the flange needs to be properly aligned to the counterflange before the bolts are tightened.

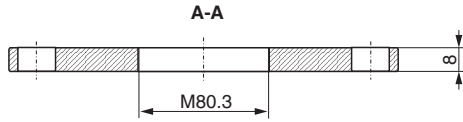

**Endress+Hauser UNI flange DN150**

- compatible with:  
 - DN150 PN10/16,  
 - ANSI 6" 150 lbs,  
 - JIS 10K 150A

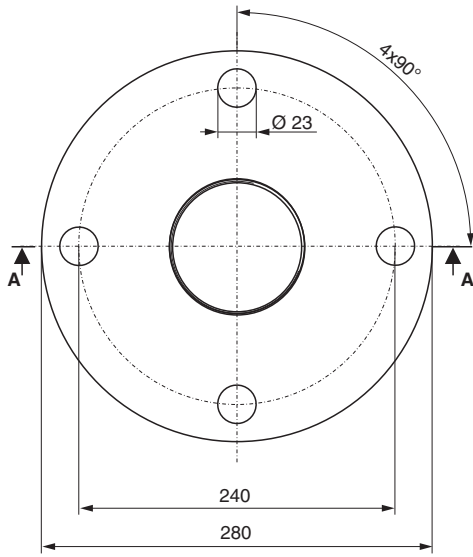

material: 316L

**Endress+Hauser UNI flange DN200**

- compatible with:  
 - DN200 PN10/16,  
 - ANSI 8" 150 lbs,  
 - JIS 10K 200A

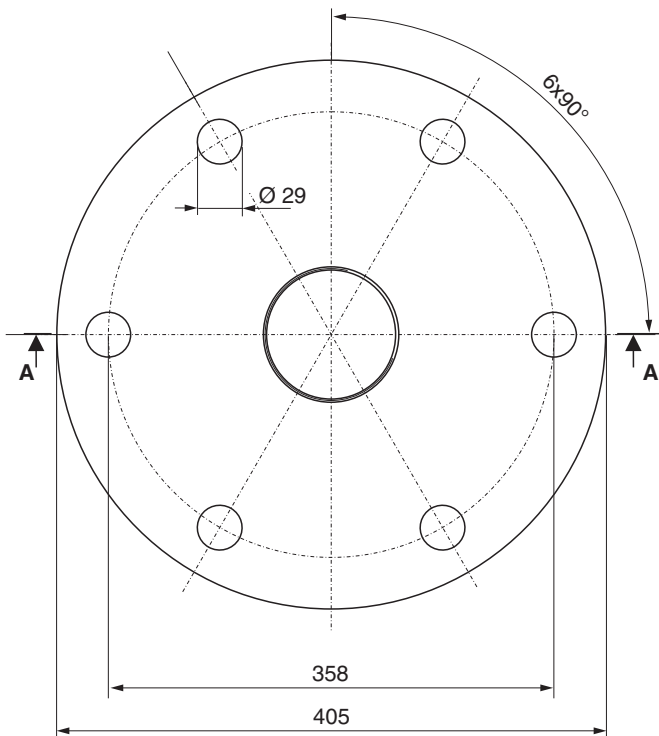
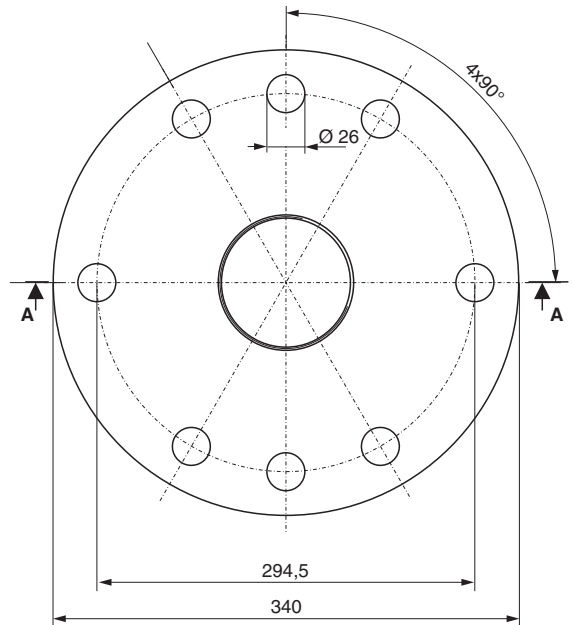

**Endress+Hauser UNI flange DN250**

- compatible with:  
 - DN250 PN10/16,  
 - ANSI 10" 150 lbs,  
 - JIS 10K 250A

**Top target positioner (Sensor alignment) with Endress+Hauser UNI flange**

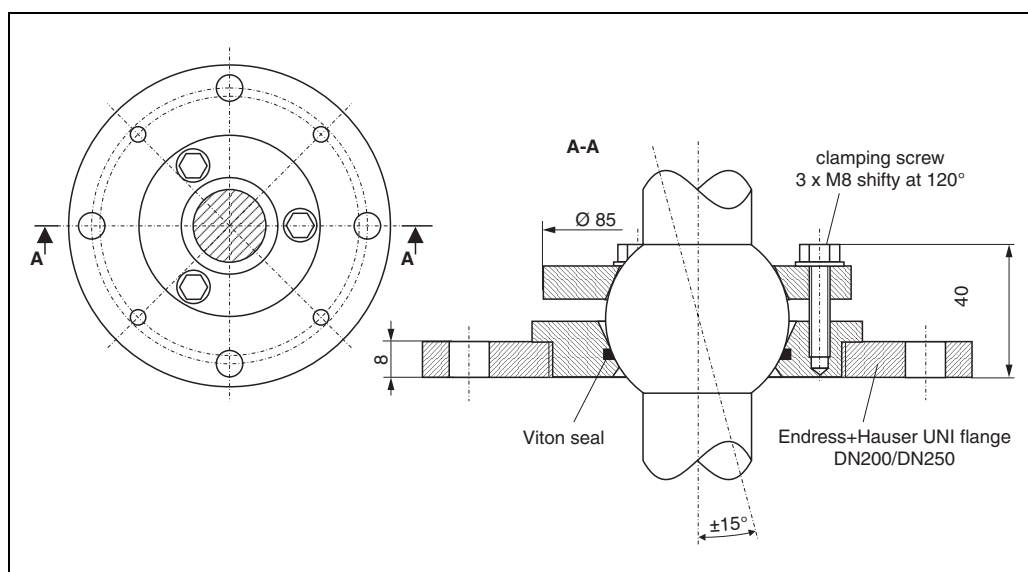

L00-FMR540xx-06-00-00-en-003

Please, also see sensor alignment tool → 32.

**Weight**

Micropilot S	FMR540
Weight T12 housing	Approx. 6 kg + weight of flange

Please, refer to ordering information → 30.

**Material**

- Housing T12: aluminium, seawater-resistant, chromated, powder-coated
- Sight window: glass



## Human interface

### Operation concept

The display of the process value and the configuration of the Micropilot is done locally by means of a large 4-line alphanumeric display with plain text information. The guided menu system with integrated help texts ensures a quick, safe and easy commissioning.

Display and operation is selectable from one out of six languages (English, German, French, Italian, Dutch, Spanish and Japanese). During the first start-up, the instrument explicitly asks for the desired unit / language. To access the display the cover of the electronic compartment may be removed even in hazardous area (Ex ia, IS).

Remote commissioning, including documentation of the measuring point and in-depth analysis functions, is supported via the ToF Tool, the graphical operating software for Endress+Hauser time-of-flight systems. Access to the electronics can be prevented by means of a custody locking switch that locks the device settings. The custody locking switch can be sealed for custody transfer applications.

### Display elements

#### Liquid crystal display (LCD):

Four lines with 20 characters each. Display contrast adjustable through key combination.

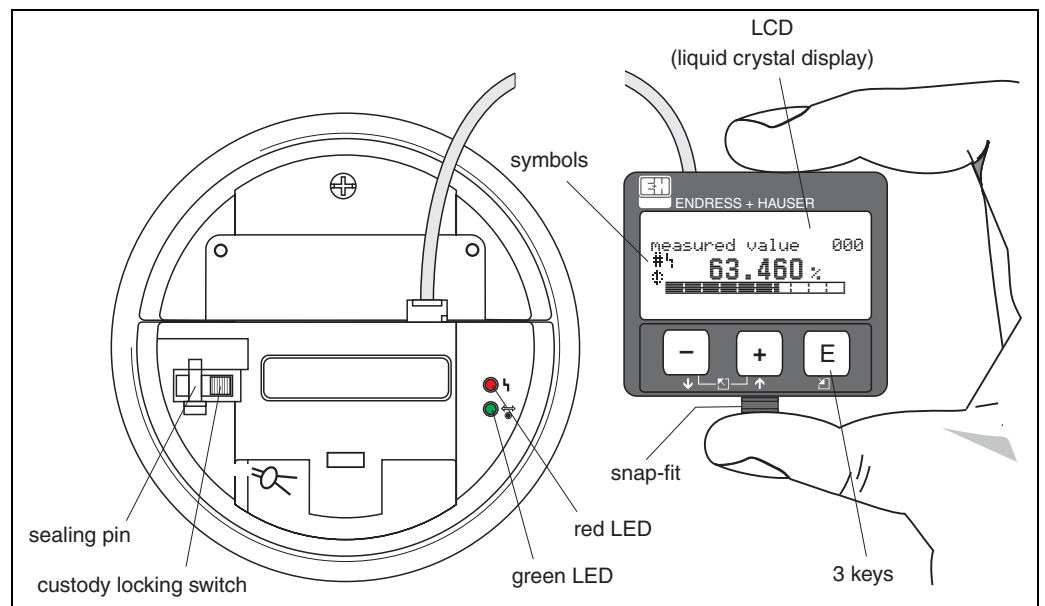

#### Note!

To access the display, it is possible to open the cover of the electronics compartment even in an explosion hazardous area.

The VU331 LCD display can be removed to ease operation by simply pressing the snap-fit (see graphic above). It is connected to the device by means of a 500 mm cable.

#### Display symbols

The following table describes the symbols that appear on the liquid crystal display:

Symbols	Meaning
	<b>ALARM_SYMBOL</b> This alarm symbol appears when the instrument is in an alarm state. If the symbol flashes, this indicates a warning.
	<b>LOCK_SYMBOL</b> This lock symbol appears when the instrument is locked, i.e. if no input is possible.
	<b>COM_SYMBOL</b> This communication symbol appears when a data transmission via e.g. HART is in progress.
	<b>Calibration to regulatory standards disturbed</b> If the instrument is not locked or it cannot guarantee the calibration to regulatory standards, the situation will be indicated on the display via the symbol.

**Light emitting diodes (LEDs):**















There is a green and a red LED besides the Liquid Crystal Display.

LED	Meaning
red LED continuously on	Alarm
red LED flashes	Warning
red LED off	No alarm
green LED continuously on	Operation
Green LED flashes	Communication with external device

**Operating elements**

The operating elements are located inside the housing and are accessible for operation by opening the lid of the housing.

**Function of the keys**

Key(s)	Meaning
 or 	Navigate upwards in the selection list Edit numeric value within a function
 or 	Navigate downwards in the selection list Edit numeric value within a function
  or 	Navigate to the left within a function group
	Navigate to the right within a function group
 and  or  and 	Contrast settings of the LCD
 and  and 	Hardware lock / unlock After a hardware lock, an operation of the instrument via display or communication is not possible! The hardware can only be unlocked via the display. An unlock parameter must be entered to do so.

On-site configuration

Operation with VU331

The LC-Display VU331 allows configuration via 3 keys directly at the instrument. All device functions can be set through a menu system. The menu consists of function groups and functions. Within a function, application parameters can be read or adjusted. The user is guided through a complete configuration procedure.

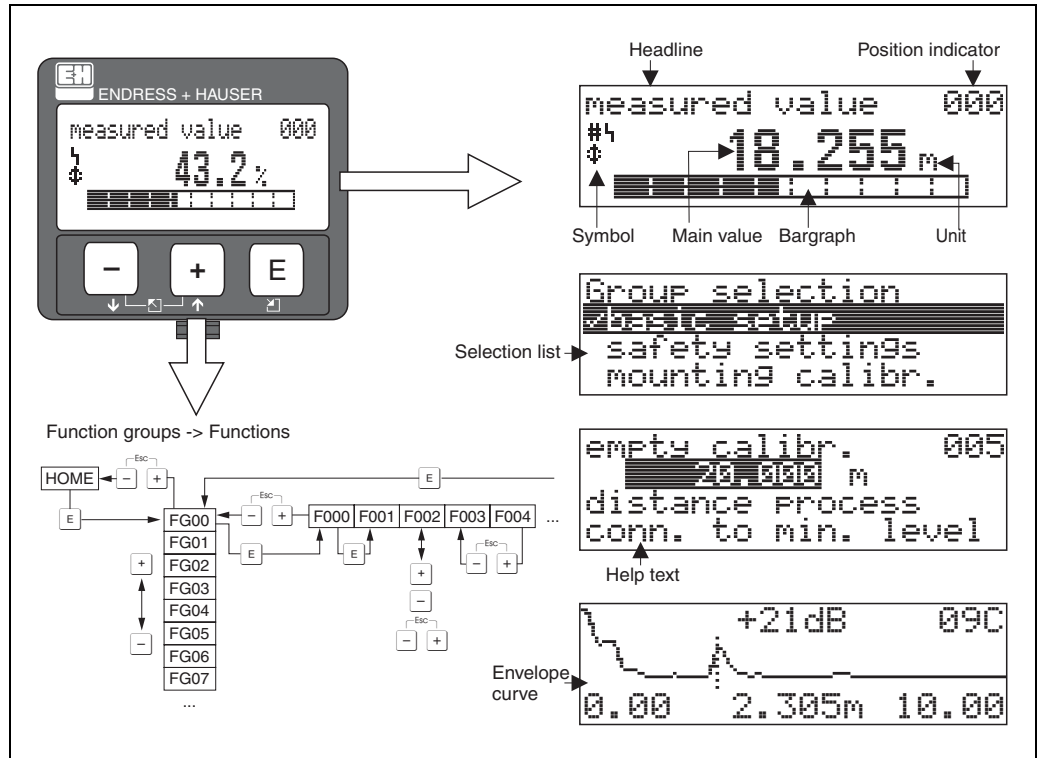

L00-FMRxxxxx-07-00-00-en-002

Operation with handheld unit Field Communicator DXR375

All device functions can be adjusted via a menu operation with the handheld unit DXR375.

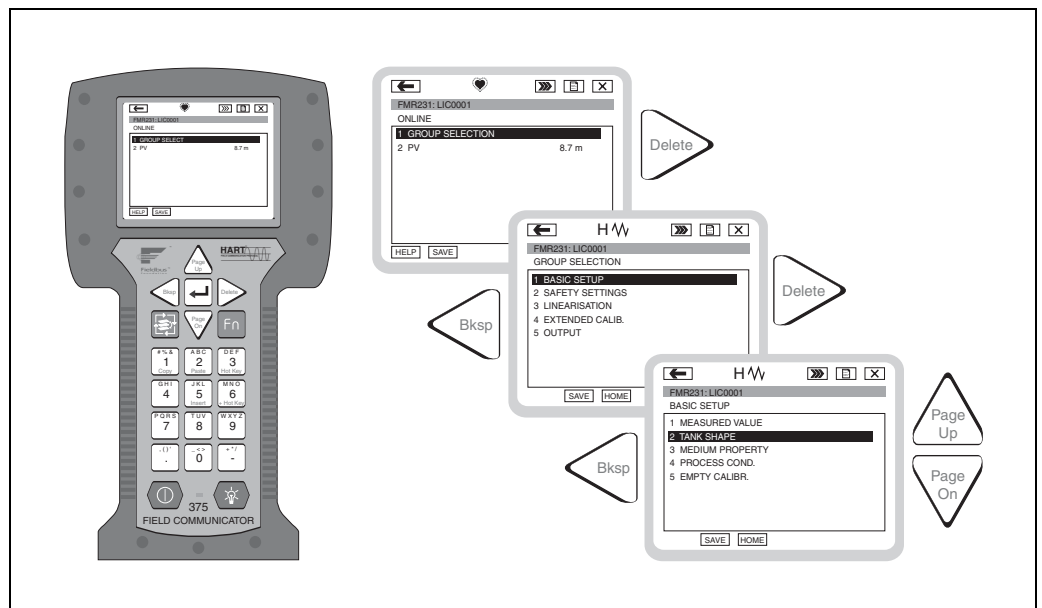

L00-FMRxxxxx-07-00-00-yy-007

Note!

Further information on the handheld unit is given in the respective operating manual included in the transport bag of the DXR375.

## Remote configuration

The Micropilot S can be remotely operated via HART. On-site adjustments are also possible.

### Operation with ToF Tool

The ToF Tool is a graphical operation software for instruments from Endress+Hauser that operate based on the time-of-flight principle. It is used to support commissioning, securing of data, signal analysis and documentation of the instruments. It is compatible with the following operating systems: WinNT4.0, Win2000 and WinXP.

The ToF Tool supports the following functions:

- Online configuration of transmitters
- Signal analysis via envelope curve
- Linearisation table (create, edit, import and export)
- Loading and saving of instrument data (Upload/Download)
- Documentation of measuring point

Menu-guided commissioning:

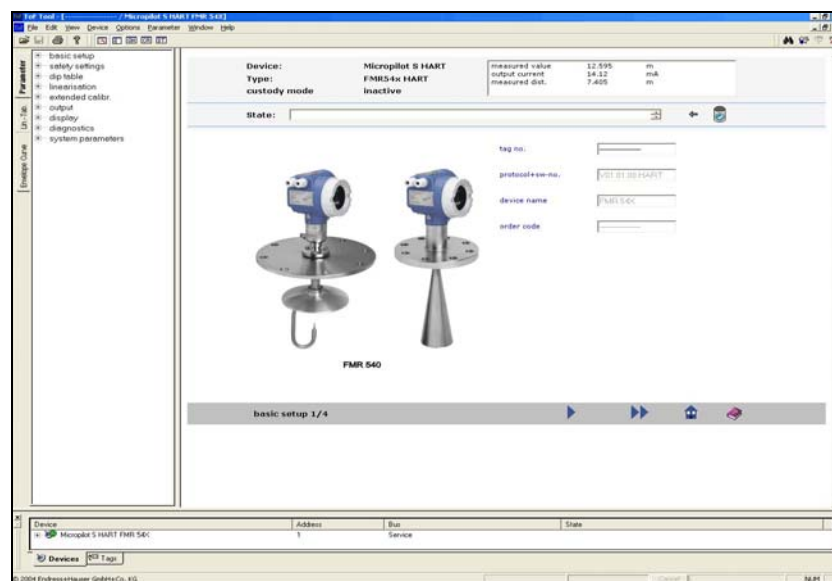

100-FMR540xx-20-00-00-en-001

Signal analysis via envelope curve:

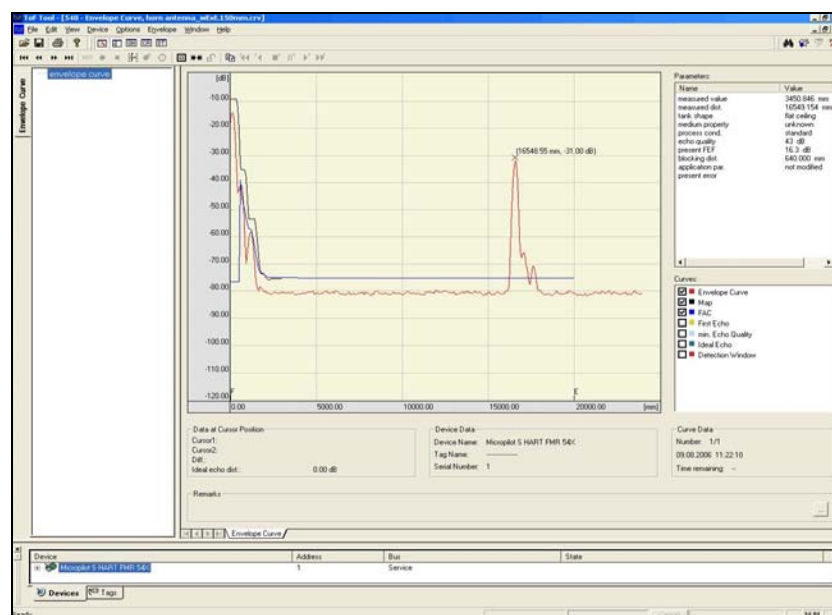

100-FMR540xx-20-00-00-de-001

Connection options:

- HART with Commubox FXA191, FXA195
- Service-interface with adapter FXA193 (RS232C) or FXA291 and ToF Adapter FXA291 (USB)

### Operation with FieldCare

FieldCare is Endress+Hauser's FDT based Plant Asset Management Tool. It can configure all intelligent field devices in your plant and supports you in managing them. By using status information, it also provides a simple but effective means of checking their health.

- Operates all Endress+Hauser devices
- Operates all third-party actuators, I/O systems and sensors supporting the FDT standard
- Ensures full functionality for all devices with DTMs
- Offers generic profile operation for any third-party fieldbus device that does not have a vendor DTM

## Certificates and approvals

---

<b>CE approval</b>	The measuring system meets the legal requirements of the EC-guidelines. Endress+Hauser confirms the instrument passing the required tests by attaching the CE-mark.
<b>Ex approval</b>	See "Ordering information" on →  30.
<b>External standards and guidelines</b>	<p>To conception and development for Micropilot S have been followed the external standards and guidelines:</p> <p><b>EN 60529</b> Protection class of housing (IP-code)</p> <p><b>EN 61010</b> Safety regulations for electrical devices for measurement, control, regulation and laboratory use.</p> <p><b>EN 61326</b> Emissions (equipment class B), compatibility (appendix A – industrial area)</p> <p><b>NAMUR</b> Standards committee for measurement and control in the chemical industry</p> <p><b>API (American Petroleum Institute)</b> Particularity "Manual of Petroleum Measurement Standards"</p> <p><b>OIML R85 (Organisation Internationale de Métrologie Légale)</b></p>
<b>Type approvals for custody transfer approvals</b>	All aspects of OIML R85 are fulfilled
<b>RF approvals</b>	R&TTE 1999/5/EG, FCC CRF 47, part 15

## Ordering information

### Micropilot S FMR540

This overview does not mark options which are mutually exclusive.

10	Approval:		Basic weight
	A	Non-hazardous area	
	1	ATEX II 1/2G EEx ia IIC T6	
	6	*ATEX II 1/2G EEx ia IIC T6, WHG (in preparation)	
	G	*ATEX II 3G EEx nA II T6 (in preparation)	
	S	*FM IS Cl.I Div.1 Gr.A-D (in preparation)	
	U	*CSA IS Cl.I Div.1 Gr.A-D (in preparation)	
	K	*TIIS Ex ia IIC T3 (in preparation)	
	L	*TIIS Ex ia IIC T6 (in preparation)	
	Y	Special version	6.0 Kg (T12 Transmitter housing)
20	Antenna; Seal:		
	5	100mm/4" horn; FKM Viton GLT	0.6 Kg
	6	200mm/8" Parabolic, FKM Viton GLT	0.3 Kg
	9	Special version	
30	Antenna Extension:		Additional weight
	1	W/o	1.8 Kg
	2	150mm/6"	2.0 Kg
	3	250mm/10"	2.3 Kg
	4	450mm/18"	2.9 Kg
	9	Special version	
40	Process connection:		Additional weight
		– EN-Flanges –	
	CQJ	DN100 PN10/16 B1, 316L	4.9 Kg
	CWJ	DN150 PN10/16 B1, 316L	10.6 Kg
		– ASME-Flanges –	
	APJ	4" 150lbs RF, 316/316L	7.0 Kg
	AVJ	6" 150lbs RF, 316/316L flange B16.5	11.3 Kg
		– JIS-Flanges –	
	KH5	10K 100 RF, 316L flange JIS	4.5 Kg
	KV5	10K 150 RF, 316L flange JIS	10.1 Kg
		– Miscellaneous –	
	XVJ	UNI flange DN150/6"/150, 316L Max PN1/14.5lbs/1K, suitable for DN150 PN10/16, 6" 150lbs, 10K 150	3.4 Kg
	X3J	UNI flange DN200/8"/200, 316L Max PN1/14.5lbs/1K, suitable for DN200 PN10/16, 8" 150lbs, 10K 200	4.4 Kg
	X5J	UNI flange DN250/10"/250, 316L Max PN1/14.5lbs/1K, suitable for DN250 PN10/16, 10" 150lbs, 10K 250	5.4 Kg
	XDJ	align. device., UNI 6"/DN150/150, 316L max 14.5lbs/PN1/1K, suitable for 6" 150lbs / DN150 PN16 / 10K 150	5.8 Kg
	XEJ	align. device., UNI 8"/DN200/200, 316L max 14.5lbs/PN1/1K, suitable for 8" 150lbs / DN200 PN16 / 10K 200	4.9 Kg
	XFJ	align. device., UNI 10"/DN250/250, 316L max 14.5lbs/PN1/1K, suitable for 10" 150lbs / DN250 PN16 / 10K 250	5.9 Kg
	YY9	Special version	
FMR540-			Product designation (part 1)

**Ordering structure  
(continued)**

<b>50</b>					<b>Output; Operation:</b>				
					A	4-20mA HART; 4-line display VU331, envelope curve display on site			
					Y	Special version			
					<b>Housing:</b>				
					C	T12 Alu, coated IP68 NEMA4X, separate connection compartment			
					Y	Special version			
	<b>70</b>					<b>Cable entry:</b>			
						1	Thread M20		
						2	Gland M20		
						3	Thread G1/2		
					4	Thread NPT1/2			
				9	Special version				
<b>80</b>					<b>Weight + Measure Approval:</b>				
					A	NMi + PTB (<1mm) weight & measure approval			
					F	NMi witnessed initial verificat. (<1mm) Type approval			
					G	*PTB witnessed initial verificat. (<1mm) (in preparation) Type approval			
					R	Not selected; Inventory control Version (3mm)			
					Y	Special version			
<b>90</b>					<b>Additional Option:</b>				
					A	Basic version			
					Y	Special version			
					FMR540-				
								Complete product designation	

## Accessories

### Weather protection cover

A Weather protection cover made of stainless steel is recommended for outdoor mounting (order code: 543199-0001). The shipment includes the protective cover and tension clamp.

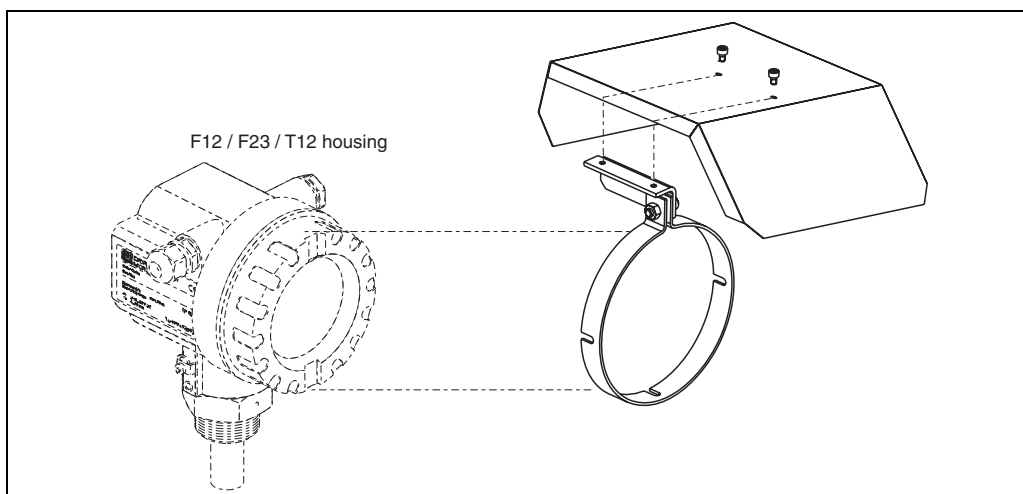

L00-FMR2xxx-00-00-06-en-001

### Sensor alignment tool for Target Positioner (alignment device option) only

A sensor alignment tool is recommended to be used at the time of installation for FMR540 with Top Target Positioner (alignment device feature). Order code: 52026756  
For instructions see document KA267F/00/A2.

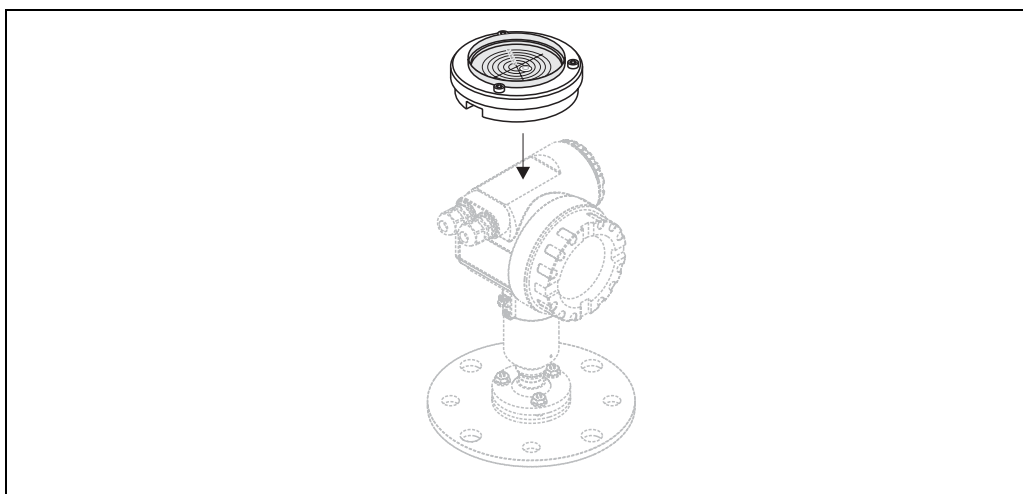

L00-FMR540xx-00-00-00-en-001

### Commubox FXA191 HART

For intrinsically safe communication with ToF Tool/FieldCare via the RS232C interface. For details refer to TI237F/00/en.

### Commubox FXA195 HART

For intrinsically safe communication with ToF Tool/FieldCare via the USB interface. For details refer to TI404F/00/en.



---

**Commubox FXA291**

The Commubox FXA291 connects Endress+Hauser field instruments with CDI interface (= Endress+Hauser Common Data Interface) to the USB interface of a personal computer or a notebook. For details refer to TI405C/07/en.

Note!

For the following Endress+Hauser instruments you need the "ToF Adapter FXA291" as an additional accessory:

- Cerabar S PMC71, PMP7x
- Deltabar S PMD7x, FMD7x
- Deltapilot S FMB70
- Gammapilot M FMG60
- Levelflex M FMP4x
- Micropilot FMR130/FMR131
- Micropilot M FMR2xx
- Micropilot S FMR53x, FMR540
- Prosonic FMU860/861/862
- Prosonic M FMU4x
- Tank Side Monitor NRF590 (with additional adapter cable)

---

**ToF Adapter FXA291**

The ToF Adapter FXA291 connects the Commubox FXA291 via the USB interface of a personal computer or a notebook to the following Endress+Hauser instruments:

- Cerabar S PMC71, PMP7x
- Deltabar S PMD7x, FMD7x
- Deltapilot S FMB70
- Gammapilot M FMG60
- Levelflex M FMP4x
- Micropilot FMR130/FMR131
- Micropilot M FMR2xx
- Micropilot S FMR53x, FMR540
- Prosonic FMU860/861/862
- Prosonic M FMU4x
- Tank Side Monitor NRF590 (with additional adapter cable)

For details refer to KA271F/00/a2.

## Documentation

**Fields of activities**      **Level Measurement**  
Limit detection and continuous level measurement in liquids and bulk solids, FA001/F/00/en.

**Technical Information**      **Fieldgate FXA320, FXA520**  
Technical Information for Fieldgate FXA320/520, TI369F/00/en.

**Tank Side Monitor NRF590**  
Technical Information for Tank Side Monitor NRF590, TI374F/00/en.

**Operating Instructions**      Operating instructions for FMR540:

Instrument	Output	Communication	Operating Instructions	Description of Instrument Functions	Brief Operating Instructions (in the Instrument)
FMR540	A	HART	BA326F/00/en	BA341F/00/en	KA255F/00/A2

**Certificates**      Safety instructions (XA) and certificates (ZE) for FMR540:

Instrument	Certificate	Explosion protection	Output	Communication	PTB 00 ATEX	XA	WHG
FMR540	1	ATEX II 1/2 G EEx ia IIC T6	A	HART	2067X	XA338F/00/a3	
	6	ATEX II 1/2 G EEx ia, WHG					in preparation
	G	ATEX II 3 G EEx nA II T6					in preparation

Control Drawings (ZD) for FMR540:

Instrument	Certificate	Explosion protection	Output	Communication	ZD
FMR540	S	FM IS	A	HART	ZD194F/00/en
	U	CSA IS			ZD196F/00/en

## Patents

---

This product may be protected by at least one of the following patents.  
Further patents are pending.

- US 5,387,918 ≅ EP 0 535 196
- US 5,689,265 ≅ EP 0 626 063
- US 5,659,321
- US 5,614,911 ≅ EP 0 670 048
- US 5,594,449 ≅ EP 0 676 037
- US 6,047,598
- US 5,880,698
- US 5,926,152
- US 5,969,666
- US 5,948,979
- US 6,054,946
- US 6,087,978
- US 6,014,100

---

## International Head Quarter

Endress+Hauser  
GmbH+Co. KG  
Instruments International  
Colmarer Str. 6  
79576 Weil am Rhein  
Deutschland

Tel. +49 76 21 9 75 02  
Fax +49 76 21 9 75 34 5  
[www.endress.com](http://www.endress.com)  
[info@ii.endress.com](mailto:info@ii.endress.com)

**Endress+Hauser**   
People for Process Automation