



FCC DFS Test Report

FCC ID: L9VWAP5903

Original Grant

Report No. : TB-FCC171065
Applicant : COMTREND Corporation
Equipment Under Test (EUT)
EUT Name : AC1200 Dual Band WiFi Mesh Extender
Model No. : WAP-5903
Series Model No. : N/A
S/N Number: : M1914000765, M1914000766
Brand Name : COMTREND
Receipt Date : 2019-12-05
Test Date : 2019-12-07 to 2020-03-24
Issue Date : 2020-03-25
Standards : 47 CFR FCC Part 15.407
Test Method : KDB 905462 D02 UNII DFS Compliance Procedures New Rules v02
Conclusions : **PASS**

In the configuration tested, the EUT complied with the standards specified above,
The EUT technically complies with the FCC and IC requirements

Test/Witness Engineer :  Jack Deng
Test/Witness Engineer :  Ivan Su
Approved & Authorized :  Benny Xu



This report details the results of the testing carried out on one sample. The results contained in this test report do not relate to other samples of the same product. The manufacturer should ensure that all products in series production are in conformity with the product sample detailed in the report.

Contents

- CONTENTS.....2**
- 1. GENERAL INFORMATION ABOUT EUT4**
 - 1.1. Client Information.....4
 - 1.2. General Description of EUT (Equipment Under Test)4
 - 1.3. Test Facility.....6
- 2. TEST SOFTWARE.....7**
- 3. SUPPORT EQUIPMENT.....7**
- 4. TEST EQUIPMENT.....7**
- 5. U-NII DFS RULE REQUIREMENTS8**
 - 5.1. Applicability of DFS requirements8
 - 5.2. Test Limits and Radar Signal Parameters9
- 6. CALIBRATION OF RADAR WAVEFORM14**
 - 6.1. Test Procedure.....14
 - 6.2. Conducted Calibration Test Setup15
 - 6.3. Deviation from Test Standard15
 - 6.4. Radar Waveform Calibration Result15
- 7. U-NII DFS TESTING16**
 - 7.1. Test Procedure.....16
 - 7.2. Test Setup.....16
- 8. TESTING RESULTS.....17**
 - 8.1. Summary of Test Results17
 - 8.2. DFS Detection Threshold17
 - 8.3. Radar Waveform Calibration.....18
 - 8.4. Channel Availability Check Time.....29
 - 8.5. In-Service(Pd).....35
 - 8.6. Channel Move Time and Channel Closing Transmission Time41
 - 8.7. Non-occupancy Period.....47
 - 8.8. Uniform Spreading48
 - 8.9. U-NII Detection Bandwidth48

1. General Information about EUT

1.1. Client Information

Applicant	:	COMTREND Corporation
Address	:	3F-1, 10 Lane 609, Chung Hsin Road, Section 5, San Chung Dist, New Taipei City, Taiwan 24159
Manufacturer	:	COMTREND Corporation
Address	:	3F-1, 10 Lane 609, Chung Hsin Road, Section 5, San Chung Dist, New Taipei City, Taiwan 24159
Factory	:	Shenzhen COMNECT Technology Co., Ltd.
Address	:	G Zone, 3/F, Building 1, Baisha High-Tech Park, No. 3011, Shahe Road West, XiLi Street, Nanshan District, Shenzhen, China

1.2. General Description of EUT (Equipment Under Test)

EUT Name	:	AC1200 Dual Band WiFi Mesh Extender
Models No.	:	WAP-5903
Model Difference	:	N/A.
Operating Frequency Band	:	<input checked="" type="checkbox"/> 5250-5350MHz <input checked="" type="checkbox"/> 5470-5725MHz
TPC	:	<input type="checkbox"/> No <input checked="" type="checkbox"/> Yes
Power Rating	:	Adapter(RD1201500-C55-153MG): Input: AC 100-240V, 50/60Hz, 0.6A max Output: DC 12V, 1.5A
Software Version	:	BS51-3411DCTU-C01_R03
Hardware Version	:	AR-M400 V3.0
Note	:	This device was functioned as a <input checked="" type="checkbox"/> Master <input type="checkbox"/> Slave device with radar detection <input type="checkbox"/> Slave device without radar detection

Note:

- (1) For a more detailed features description, please refer to the manufacturer's specifications or the User's Manual. and the DFS test used the EUT-2(S/N number: M1914000766).

(2) Antenna information provided by the applicant.

Antenna	Brand	Model Name	Type	Antenna Gain (dBi)	Directional Gain (dBi)
ANT. A	N/A	SLEingB400150135	copper tube	U-NII-2A: 5.23	U-NII-2A: 8.24 U-NII-2C: 8.04
				U-NII-2C: 5.03	
ANT. B	N/A	SLEingB400150135	copper tube	U-NII-2A: 5.23	
				U-NII-2C: 5.03	

Note: For MIMO mode: Directional Gain=ANT. Gain+10*LOG(N_{ANT}).

This EUT supports MIMO 2X2, any transmit signals are correlate with each other.

(3) Conducted Output Power And E.I.R.P

Mode: TX (802.11a)				
Frequency Band (MHz)	Max Conducted Output Power (dBm)	PSD (dBm/MHz)	Max E.I.R.P (dBm)	Max E.I.R.P (mW)
5260~5320	16.21	8.60	24.45	278.61
5500~5710	16.25	8.51	24.29	268.53

Mode: TX (802.11n(HT40))				
Frequency Band (MHz)	Max Conducted Output Power (dBm)	PSD (dBm/MHz)	Max E.I.R.P (dBm)	Max E.I.R.P (mW)
5260~5320	19.60	8.46	27.84	608.14
5500~5710	19.73	8.57	27.77	598.41

Mode: TX(802.11ac(VHT80))				
Frequency Band (MHz)	Max Conducted Output Power (dBm)	PSD (dBm/MHz)	Max E.I.R.P (dBm)	Max E.I.R.P (mW)
5260~5320	21.23	7.96	29.47	885.12
5500~5710	21.45	8.33	29.49	889.20

1.3. Test Facility

The testing was performed by the Shenzhen Toby Technology Co., Ltd., in their facilities located at:1A/F., Bldg.6, Yusheng Industrial Zone, The National Road No.107 Xixiang Section 467, Xixiang, Bao'an, Shenzhen, Guangdong, China.

At the time of testing, the following bodies accredited the Laboratory:

CNAS (L5813)

The Laboratory has been accredited by CNAS to ISO/IEC 17025: 2005 General Requirements for the Competence of Testing and Calibration Laboratories for the competence in the field of testing. And the Registration No.: CNAS L5813.

A2LA Certificate No.: 4750.01

The laboratory has been accredited by American Association for Laboratory Accreditation(A2LA) to ISO/IEC 17025: 2005 General Requirements for the Competence of Testing and Calibration Laboratories for the technical competence in the field of Electrical Testing. And the A2LA Certificate No.: 4750.01.FCC Accredited Test Site Number: 854351.

IC Registration No.: (11950A-1)

The Laboratory has been registered by Certification and Engineering Bureau of Industry Canada for radio equipment testing. The site registration: Site# 11950A-1.

2. Test Software

Test Item	Test Software	Manufacturer	Version No.
RF Conducted Measurement	MTS-8310	MWRFtest	V2.0.0.0

3. Support Equipment

Equipment Information				
Name	Model	S/N	Manufacturer	Used “√”
Notebook	T430	----	Thinkpad	√
Notebook	T450s	----	Thinkpad	√
USB wireless adapter	NW392	----	NET-CORE	√

4. Test Equipment

Antenna Conducted Emission					
Equipment	Manufacturer	Model No.	Serial No.	Last Cal.	Cal. Due Date
MXA Signal Analyzer	Agilent	N9020A	MY49100060	Sep. 16, 2019	Sep. 15, 2020
Vector Signal Generator	Agilent	N5182A	MY50141294	Sep. 16, 2019	Sep. 15, 2020
Analog Signal Generator	Agilent	N5181A	MY50141953	Sep. 16, 2019	Sep. 15, 2020
RF Power Sensor	DARE!! Instruments	RadiPowerRPR3006W	17I00015SNO26	Sep. 16, 2019	Sep. 15, 2020
	DARE!! Instruments	RadiPowerRPR3006W	17I00015SNO29	Sep. 16, 2019	Sep. 15, 2020
	DARE!! Instruments	RadiPowerRPR3006W	17I00015SNO31	Sep. 16, 2019	Sep. 15, 2020
	DARE!! Instruments	RadiPowerRPR3006W	17I00015SNO33	Sep. 16, 2019	Sep. 15, 2020

5. U-NII DFS Rule Requirements

5.1. Applicability of DFS requirements

The manufacturer shall state whether the UUT is capable of operating as a Master and/or a Client. If the UUT is capable of operating in more than one operating mode then each operating mode shall be tested separately. See tables 1 and 2 for the applicability of DFS requirements for each of the operational modes.

Table 3: Applicability of DFS requirements prior to use a channel

Requirement	Operational Mode		
	<input checked="" type="checkbox"/> Master	<input type="checkbox"/> Client without radar detection	<input type="checkbox"/> Client with radar detection
Non-Occupancy Period	✓	Not required	✓
DFS Detection Threshold	✓	Not required	✓
Channel Availability Check Time	✓	Not required	Not required
Uniform Spreading	✓	Not required	Not required
U-NII Detection Bandwidth	✓	Not required	✓

Table 4: Applicability of DFS requirements during normal operation

Requirement	Operational Mode		
	<input checked="" type="checkbox"/> Master	<input type="checkbox"/> Client without radar detection	<input type="checkbox"/> Client with radar detection
DFS Detection Threshold	✓	Not required	✓
Channel Closing Transmission Time	✓	✓	✓
Channel Move Time	✓	✓	✓
U-NII Detection Bandwidth	✓	Not required	✓

Additional requirements for devices with multiple bandwidth modes	<input checked="" type="checkbox"/> Master Device or Client with Radar Detection	<input type="checkbox"/> Client without Detection
Detection Bandwidth and Statistical Performance Check	All BW modes must be tested	Not required
Channel Move Time and Channel Closing Transmission Time	Test using widest BW mode available	Test using widest BW mode available
All other tests	Any single BW mode	Not required
Note: Frequencies selected for statistical performance check (section 7.8.4) should include several frequencies within the radar detection bandwidth and frequencies near the edge of the radar detection bandwidth. For 802.11 devices it is suggested to select frequencies in each of the bonded 20MHz channels and the channel center frequency.		

5.2. Test Limits and Radar Signal Parameters

DETECTION THRESHOLD VALUES

Table 5: DFS Detection Thresholds for Master Devices and Client Devices with Radar Detection.

Maximum Transmit Power	Value (See Notes 1 and 2)
EIRP ≥ 200 milliwatt	-64 dBm
EIRP < 200 milliwatt and Power spectral density < 10 dBm/MHz	-62 dBm
EIRP < 200 milliwatt that do not meet the power spectral density requirement	-64 dBm

Note 1: This is the level at the input of the receiver assuming a 0 dBi receive antenna.

Note 2: Throughout these test procedures an additional 1 dB has been added to the amplitude of the test transmission waveforms to account for variations in measurement equipment. This will ensure that the test signal is at or above the detection threshold level to trigger a DFS response.

Note 3: E.I.R.P is based on the highest antenna gain. For MIMO devices refer to KDB Publication 662911 D01.

Table 6: DFS Response Requirement Values

Parameter	Value
Non-occupancy period	Minimum 30 minutes
Channel Availability Check Time	60 seconds
Channel Move Time	10 seconds See Note 1.
Channel Closing Transmission Time	200 milliseconds + an aggregate of 60 milliseconds over remaining 10 second period. See Notes 1 and 2.
U-NII Detection Bandwidth	Minimum 100% of the UNII 99% transmission power bandwidth. See Note 3.

Note 1: Channel Move Time and the Channel Closing Transmission Time should be performed with Radar Type 0. The measurement timing begins at the end of the Radar Type 0 burst.

Note 2: The Channel Closing Transmission Time is comprised of 200 milliseconds starting at the beginning of the Channel Move Time plus any additional intermittent control signals required to facilitate a Channel move (an aggregate of 60 milliseconds) during the remainder of the 10 second period. The aggregate duration of control signals will not count quiet periods in between transmissions.

Note 3: During the U-NII Detection Bandwidth detection test, radar type 0 should be used. For each frequency step the minimum percentage of detection is 90 percent. Measurements are performed with no data traffic.

PARAMETERS OF DFS TEST SIGNALS

Step intervals of 0.1 microsecond for Pulse Width, 1 microsecond for PRI, 1 MHz for chirp width and 1 for the number of pulses will be utilized for the random determination of specific test waveforms.

Table 7: Short Pulse Radar Test Waveforms.

Radar Type	Pulse Width (μsec)	PRI (μsec)	Number of Pulses	Minimum Percentage of Successful Detection	Minimum Number of Trials
0	1	1428	18	See Note 1	See Note 1
1	1	Test A: 15 unique PRI values randomly selected from the list of 23 PRI values in Table 5a	Roundup $\left\{ \begin{array}{l} \left(\frac{1}{360} \right) \cdot \\ \left(\frac{19 \cdot 10^6}{\text{PRI}_{\mu\text{sec}}} \right) \end{array} \right\}$	60%	30
		Test B: 15 unique PRI values randomly selected within the range of 518-3066 μsec, with a minimum increment of 1 μsec, excluding PRI values selected in Test A			
2	1-5	150-230	23-29	60%	30
3	6-10	200-500	16-18	60%	30
4	11-20	200-500	12-16	60%	30
Aggregate (Radar Types 1-4)				80%	120
Note 1: Short Pulse Radar Type 0 should be used for the detection bandwidth test, channel move time, and channel closing time tests.					

A minimum of 30 unique waveforms are required for each of the Short Pulse Radar Types 2 through 4. If more than 30 waveforms are used for Short Pulse Radar Types 2 through 4, then each additional waveform must also be unique and not repeated from the previous waveforms. If more than 30 waveforms are used for Short Pulse Radar Type 1, then each additional waveform is generated with Test B and must also be unique and not repeated from the previous waveforms in Tests A or B.

Table 7a: Pulse Repetition Intervals Values for Test A.

Pulse Repetition Frequency Number	Pulse Repetition Frequency (Pulses Per Second)	Pulse Repetition Interval (Microseconds)
1	1930.5	518
2	1858.7	538
3	1792.1	558
4	1730.1	578
5	1672.2	598
6	1618.1	618
7	1567.4	638
8	1519.8	658
9	1474.9	678
10	1432.7	698
11	1392.8	718
12	1355	738
13	1319.3	758
14	1285.3	778
15	1253.1	798
16	1222.5	818
17	1193.3	838
18	1165.6	858
19	1139	878
20	1113.6	898
21	1089.3	918
22	1066.1	938
23	326.2	3066

Table 8: Long Pulse Radar Test Waveform

Radar Type	Pulse Width (µsec)	Chirp Width (MHz)	PRI (µsec)	Number of Pulses per Burst	Number of Bursts	Minimum Percentage of Successful Detection	Minimum Number of Trials
5	50-100	5-20	1000-2000	1-3	8-20	80%	30

The parameters for this waveform are randomly chosen (The center frequency for each of the 30 trials of the Bin 5 radar shall be randomly selected within 80% of the Occupied Bandwidth.) Thirty unique waveforms are required for the Long Pulse Radar Type waveforms. If more than 30 waveforms are used for the Long Pulse Radar Type waveforms, then each additional waveform must also be unique and not repeated from the previous waveforms.

Table 9: Frequency Hopping Radar Test Waveform

Radar Type	Pulse Width (μsec)	Chirp Width (MHz)	PRI (μsec)	Number of Pulses per Burst	Number of Bursts	Minimum Percentage of Successful Detection	Minimum Number of Trials
6	1	333	9	0.333	300	70%	30

6. Calibration of Radar Waveform

6.1. Test Procedure

1. A 50 ohm load is connected in place of the spectrum analyzer, and the spectrum analyzer is connected in place of the master device and the signal generator is set to CW mode. The amplitude of the signal generator is adjusted to yield a level of -62dBm as measured on the spectrum analyzer.
2. Without changing any of the instrument settings, the spectrum analyzer is reconnected to the Common port of the Spectrum Analyzer Combiner/Divider. Measure the amplitude and calculate the difference from -62dBm . Adjust the Reference Level Offset of the spectrum analyzer to this difference.
3. The spectrum analyzer displays the level of the signal generator as received at the antenna ports of the Master Device. The interference detection threshold may be varied from the calibrated value of -62dBm and the spectrum analyzer will still indicate the level as received by the Master Device.
4. Set the signal generator to produce a radar waveform, trigger a burst manually and measure the level on the spectrum analyzer. Readjust the amplitude of the signal generator as required so that the peak level of the waveform is at a displayed level equal to the required or desired interference detection threshold. Separate signal generator amplitude settings are determined as required for each radar type.

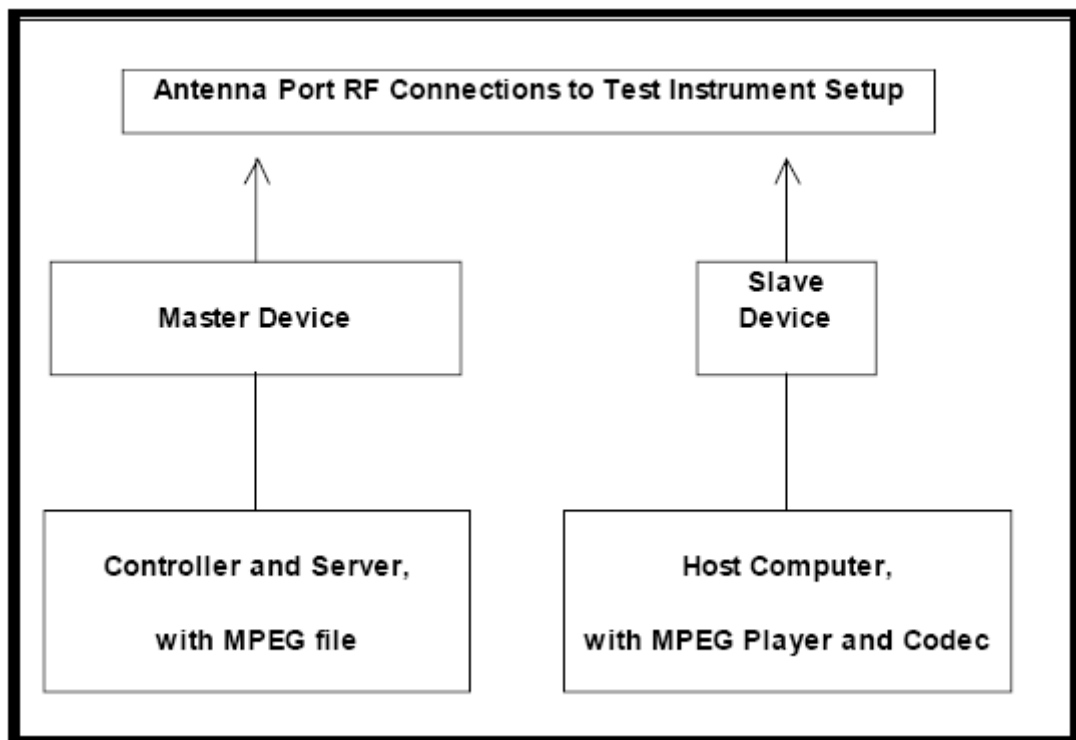

6.2. Conducted Calibration Test Setup

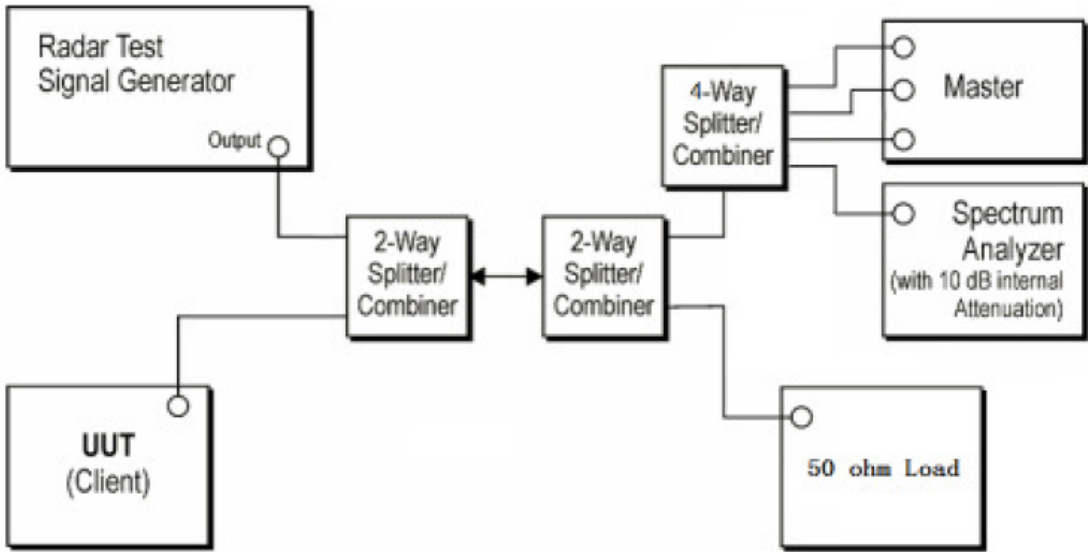

6.3. Deviation from Test Standard

No Deviation

6.4. Radar Waveform Calibration Result

7. U-NII DFS Testing

7.1. Test Procedure

1. Master device and client device are set up by conduction method as the following configuration.
2. The client device is connected to notebook and to access a IP address on wireless connection with the master device.
3. Then the master device is connected to another notebook to access a IP address.
4. Finally, let the two IP addresses run traffic with each other through the Run flow software "Lan test" to reach 17% channel loading as below:

7.2. Test Setup

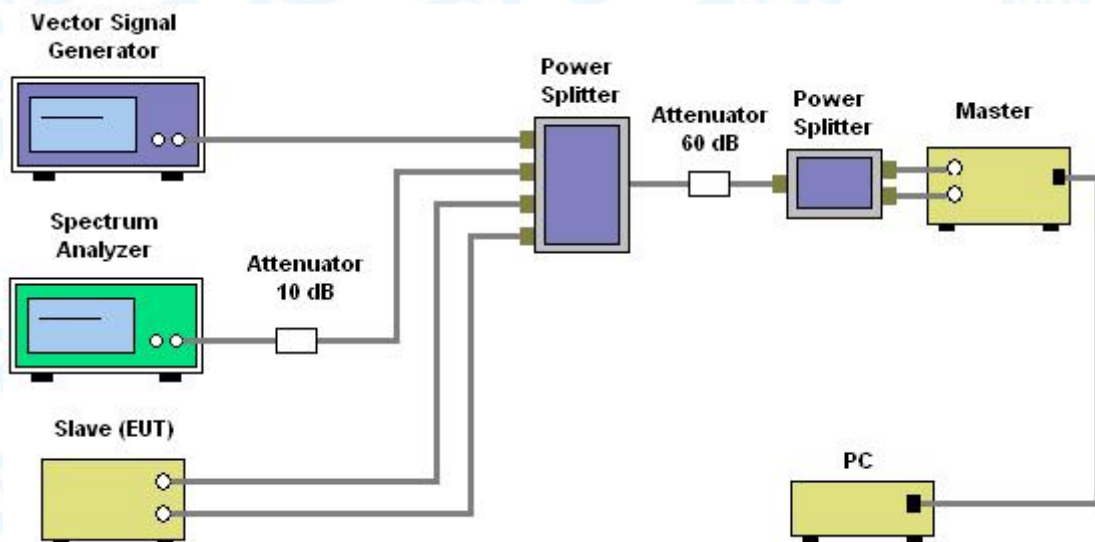

8. Testing Results

8.1. Summary of Test Results

Clause	Test Parameter	Remarks	Pass/Fail
15.407	DFS Detection Threshold	Applicable	Pass
15.407	Channel Availability Check Time	Applicable	Pass
15.407	Channel Move Time	Applicable	Pass
15.407	Channel Closing Transmission Time	Applicable	Pass
15.407	Non- Occupancy Period	Applicable	Pass
15.407	Uniform Spreading	Applicable	Pass
15.407	U-NII Detection Bandwidth	Applicable	Pass
Test Mode			
Device operating in master mode. Master with injection at the Master. (Radar Test Waveforms are injected into the Master)			

8.2. DFS Detection Threshold

Calibration:

For a detection threshold level of -64dBm and the Master antenna gain is 5.23dBi, required detection threshold is $-58.77\text{dBm} = (-64 + 5.23)\text{dBm}$.

To meet the stringent requirement, the DFS test used the detection threshold level of -64dBm.

Note: Maximum Transmit Power is more than 200 milliwatt in this report, so detection threshold level is -64dBm (please refer to page 5).

8.3. Radar Waveform Calibration

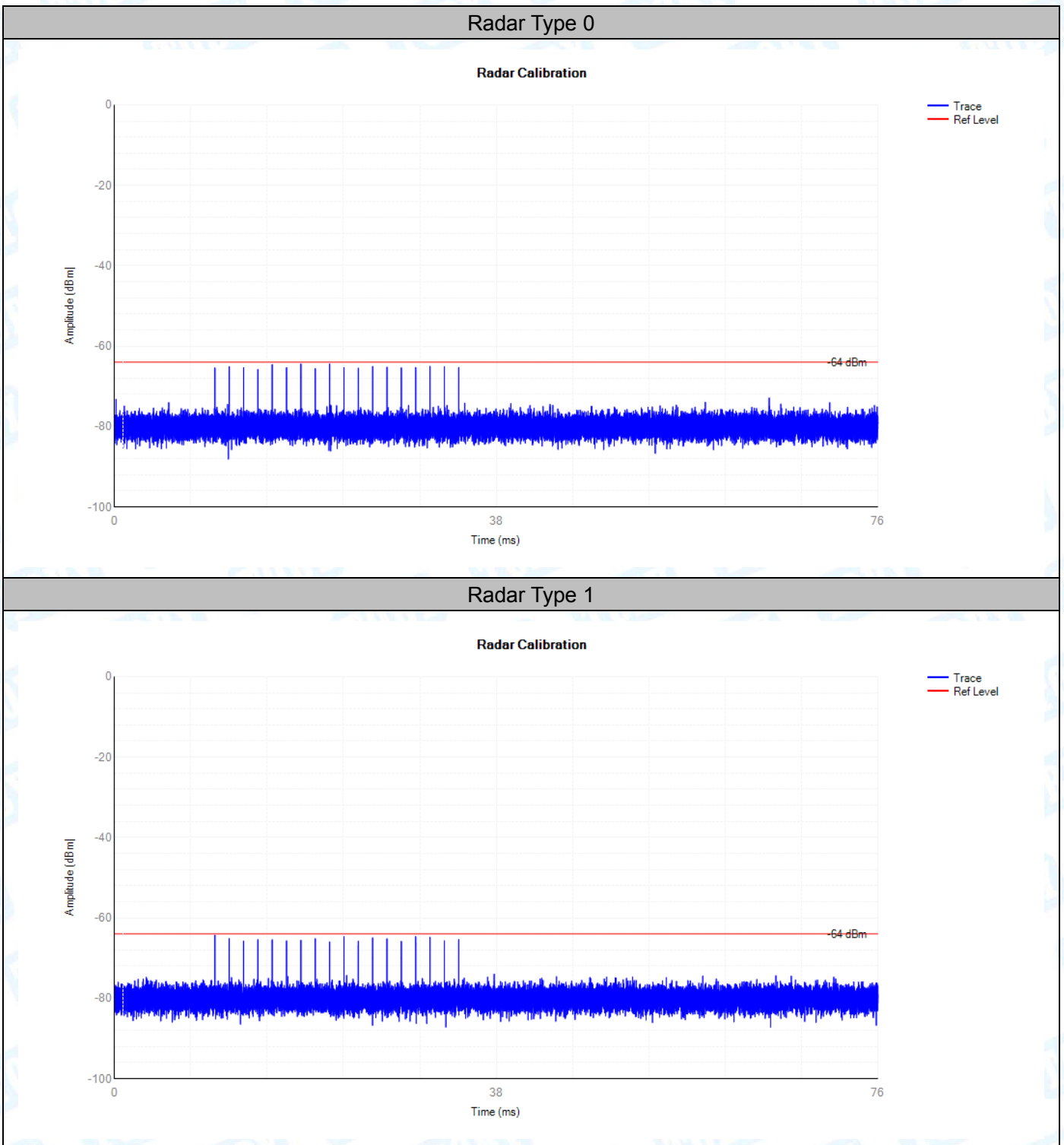

Radar Type 2

Radar Calibration

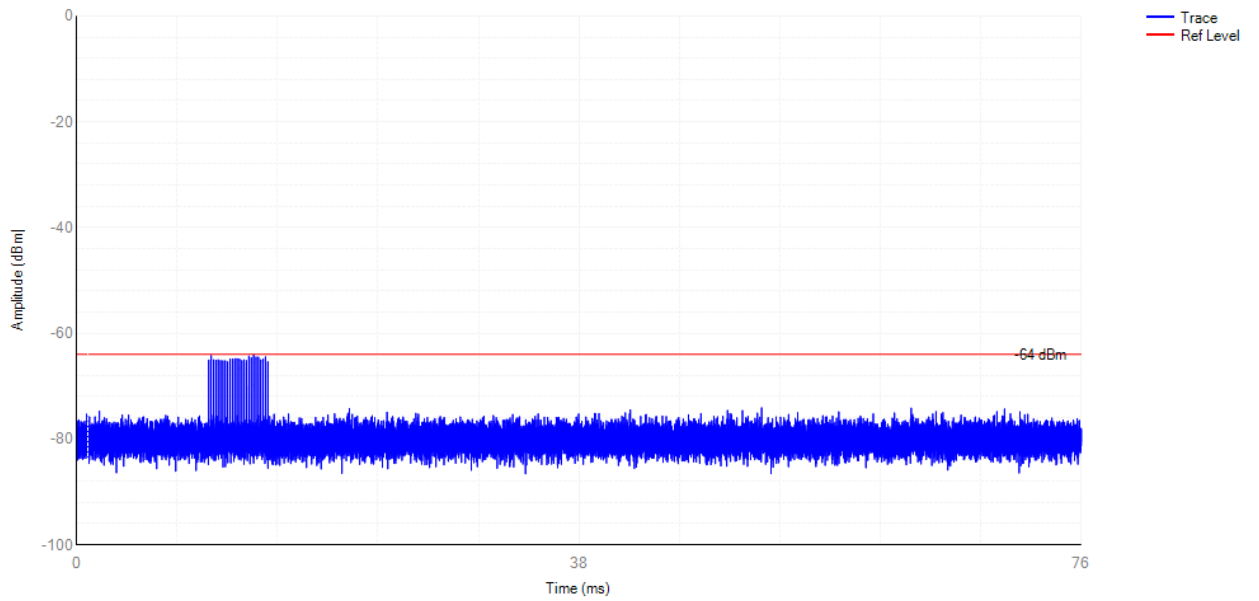

Radar Type 3

Radar Calibration

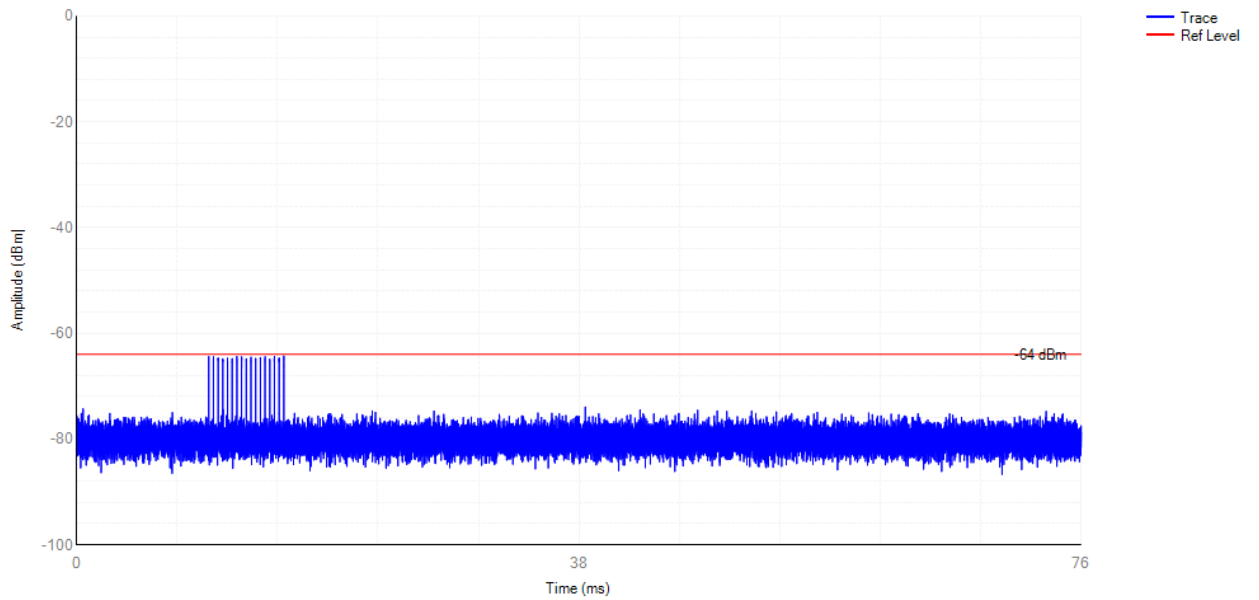

Radar Type 4

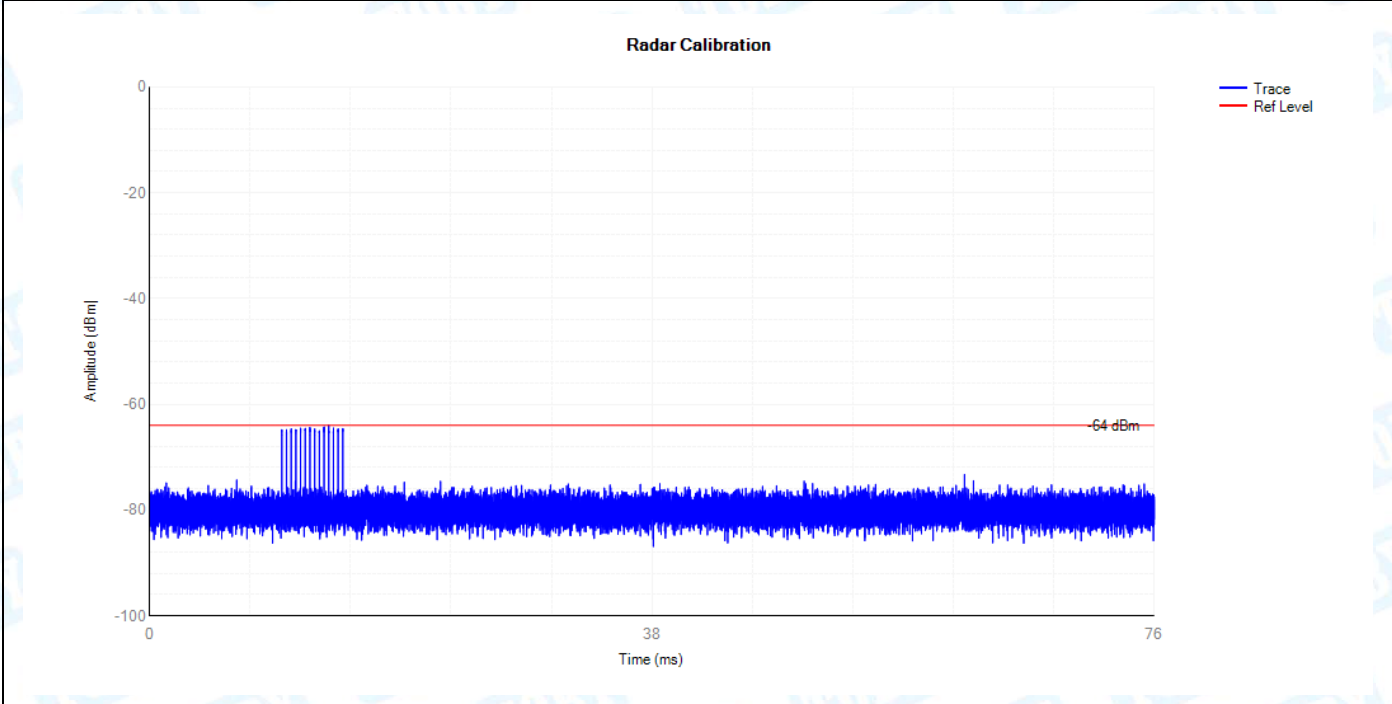

Radar Type 5

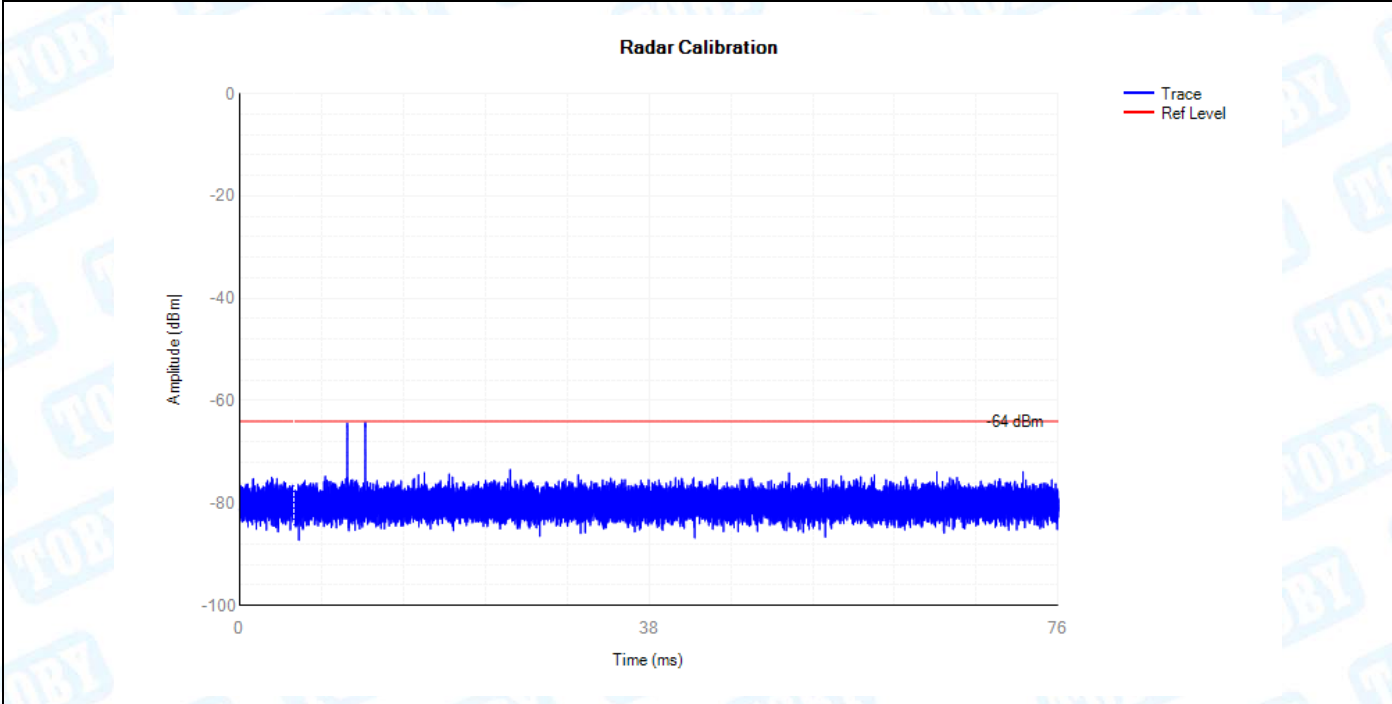

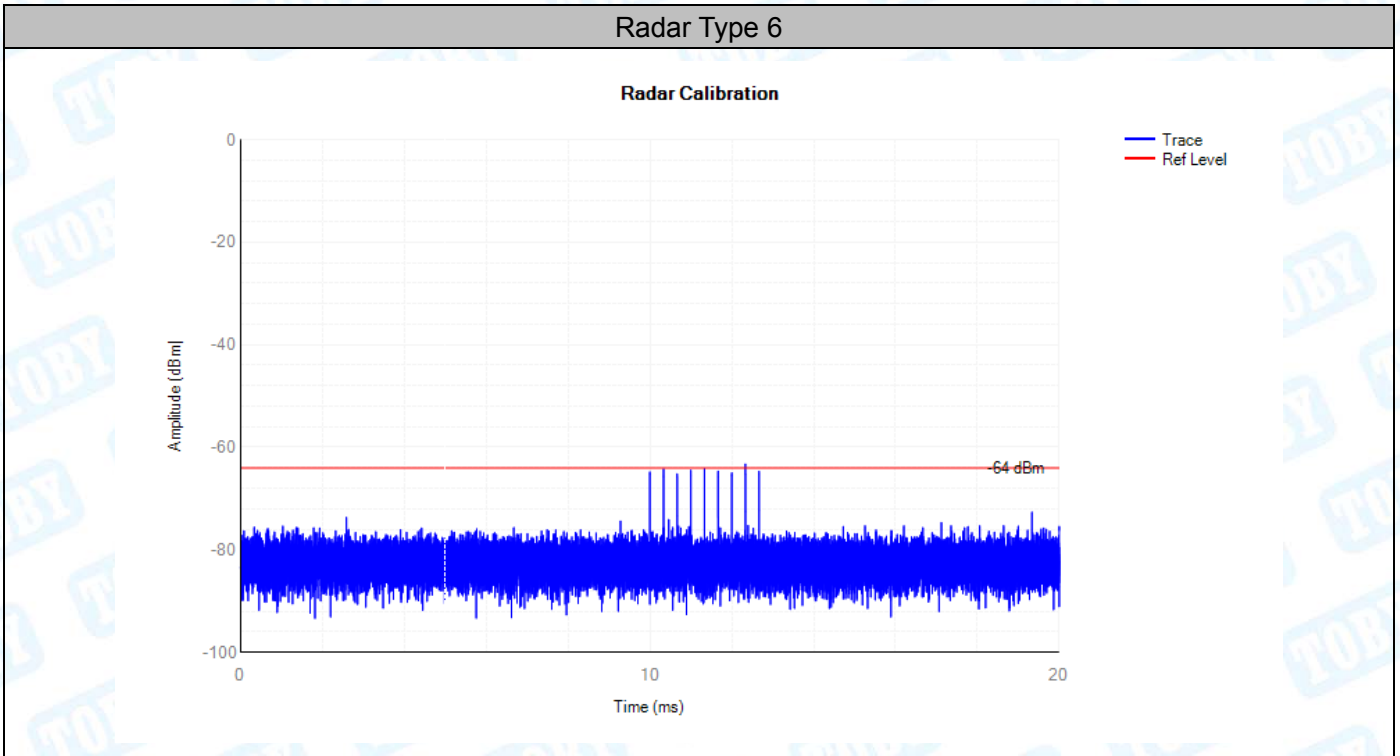

Radar Signal 0					
Trial ID	Radar Type	Pulse Width (us)	PRI (us)	Number of Pulses	Waveform Length (us)
0	Type 0	1	1428	18	25704
1	Type 0	1	1428	18	25704
2	Type 0	1	1428	18	25704
3	Type 0	1	1428	18	25704
4	Type 0	1	1428	18	25704
5	Type 0	1	1428	18	25704
6	Type 0	1	1428	18	25704
7	Type 0	1	1428	18	25704
8	Type 0	1	1428	18	25704
9	Type 0	1	1428	18	25704
10	Type 0	1	1428	18	25704
11	Type 0	1	1428	18	25704
12	Type 0	1	1428	18	25704
13	Type 0	1	1428	18	25704
14	Type 0	1	1428	18	25704
15	Type 0	1	1428	18	25704
16	Type 0	1	1428	18	25704
17	Type 0	1	1428	18	25704
18	Type 0	1	1428	18	25704
19	Type 0	1	1428	18	25704
20	Type 0	1	1428	18	25704
21	Type 0	1	1428	18	25704
22	Type 0	1	1428	18	25704
23	Type 0	1	1428	18	25704
24	Type 0	1	1428	18	25704
25	Type 0	1	1428	18	25704
26	Type 0	1	1428	18	25704
27	Type 0	1	1428	18	25704
28	Type 0	1	1428	18	25704
29	Type 0	1	1428	18	25704

Radar Signal 1					
Trial ID	Radar Type	Pulse Width (us)	PRI (us)	Number of Pulses	Waveform Length (us)
0	Type 1	1	938	57	53466
1	Type 1	1	698	76	53048
2	Type 1	1	618	86	53148
3	Type 1	1	538	99	53262
4	Type 1	1	878	61	53558
5	Type 1	1	3066	18	55188
6	Type 1	1	638	83	52954
7	Type 1	1	918	58	53244
8	Type 1	1	838	63	52794
9	Type 1	1	858	62	53196
10	Type 1	1	798	67	53466
11	Type 1	1	718	74	53132
12	Type 1	1	578	92	53176
13	Type 1	1	598	89	53222
14	Type 1	1	558	95	53010
15	Type 1	1	2536	21	53256
16	Type 1	1	966	55	53130
17	Type 1	1	827	64	52928
18	Type 1	1	2501	22	55022
19	Type 1	1	2595	21	54495
20	Type 1	1	1114	48	53472
21	Type 1	1	1302	41	53382
22	Type 1	1	3045	18	54810
23	Type 1	1	1624	33	53592
24	Type 1	1	2878	19	54682
25	Type 1	1	1027	52	53404
26	Type 1	1	2485	22	54670
27	Type 1	1	1600	33	52800
28	Type 1	1	1172	46	53912
29	Type 1	1	1177	45	52965

Radar Signal 2					
Trial ID	Radar Type	Pulse Width (us)	PRI (us)	Number of Pulses	Waveform Length (us)
0	Type 2	3.2	179	26	4654
1	Type 2	1.1	207	23	4761
2	Type 2	2.1	230	24	5520
3	Type 2	4.8	200	29	5800
4	Type 2	3.9	214	28	5992
5	Type 2	2.9	222	26	5772
6	Type 2	3.2	204	26	5304
7	Type 2	2.5	192	25	4800
8	Type 2	3.1	164	26	4264
9	Type 2	1.2	156	23	3588
10	Type 2	3.9	210	27	5670
11	Type 2	4.6	201	29	5829
12	Type 2	3.2	162	26	4212
13	Type 2	2.2	197	25	4925
14	Type 2	4.5	163	29	4727
15	Type 2	3	203	26	5278
16	Type 2	5	168	29	4872
17	Type 2	2.4	217	25	5425
18	Type 2	2.9	191	26	4966
19	Type 2	2.3	166	25	4150
20	Type 2	3.7	150	27	4050
21	Type 2	2.2	176	25	4400
22	Type 2	4.9	195	29	5655
23	Type 2	2.9	202	26	5252
24	Type 2	2.5	178	25	4450
25	Type 2	1.1	206	23	4738
26	Type 2	3.8	155	27	4185
27	Type 2	4.7	157	29	4553
28	Type 2	2.4	224	25	5600
29	Type 2	4.2	159	28	4452

Radar Signal 3					
Trial ID	Radar Type	Pulse Width (us)	PRI (us)	Number of Pulses	Waveform Length (us)
0	Type 3	8.2	355	17	6035
1	Type 3	6.1	487	16	7792
2	Type 3	7.1	344	16	5504
3	Type 3	9.8	288	18	5184
4	Type 3	8.9	230	18	4140
5	Type 3	7.9	432	17	7344
6	Type 3	8.2	207	17	3519
7	Type 3	7.5	443	17	7531
8	Type 3	8.1	439	17	7463
9	Type 3	6.2	223	16	3568
10	Type 3	8.9	208	18	3744
11	Type 3	9.6	463	18	8334
12	Type 3	8.2	441	17	7497
13	Type 3	7.2	323	16	5168
14	Type 3	9.5	297	18	5346
15	Type 3	8	412	17	7004
16	Type 3	10	324	18	5832
17	Type 3	7.4	271	17	4607
18	Type 3	7.9	349	17	5933
19	Type 3	7.3	409	16	6544
20	Type 3	8.7	373	18	6714
21	Type 3	7.2	254	16	4064
22	Type 3	9.9	274	18	4932
23	Type 3	7.9	278	17	4726
24	Type 3	7.5	317	17	5389
25	Type 3	6.1	260	16	4160
26	Type 3	8.8	211	18	3798
27	Type 3	9.7	272	18	4896
28	Type 3	7.4	264	17	4488
29	Type 3	9.2	284	18	5112

Radar Signal 4					
Trial ID	Radar Type	Pulse Width (us)	PRI (us)	Number of Pulses	Waveform Length (us)
0	Type 4	16	355	14	4970
1	Type 4	11.3	487	12	5844
2	Type 4	13.5	344	13	4472
3	Type 4	19.4	288	16	4608
4	Type 4	17.5	230	15	3450
5	Type 4	15.3	432	14	6048
6	Type 4	15.9	207	14	2898
7	Type 4	14.3	443	13	5759
8	Type 4	15.8	439	14	6146
9	Type 4	11.5	223	12	2676
10	Type 4	17.4	208	15	3120
11	Type 4	19	463	16	7408
12	Type 4	16	441	14	6174
13	Type 4	13.8	323	13	4199
14	Type 4	18.9	297	16	4752
15	Type 4	15.5	412	14	5768
16	Type 4	19.9	324	16	5184
17	Type 4	14.1	271	13	3523
18	Type 4	15.2	349	14	4886
19	Type 4	13.8	409	13	5317
20	Type 4	17.1	373	15	5595
21	Type 4	13.8	254	13	3302
22	Type 4	19.8	274	16	4384
23	Type 4	15.3	278	14	3892
24	Type 4	14.5	317	13	4121
25	Type 4	11.3	260	12	3120
26	Type 4	17.3	211	15	3165
27	Type 4	19.2	272	16	4352
28	Type 4	14.2	264	13	3432
29	Type 4	18.2	284	15	4260

Radar Signal 5					
Trial ID	Radar Type	Pulse Width (us)	PRI (us)	Number of Pulses	Center Frequency (GHz)
0	Type 5	15	0.8	12	5.5525
1	Type 5	8	1.5	12	5.5325
2	Type 5	11	1.0909091	12	5.5415
3	Type 5	20	0.6	12	5.5665
4	Type 5	17	0.7058824	12	5.5585
5	Type 5	14	0.8571429	12	5.5495
6	Type 5	15	0.8	12	5.5515
7	Type 5	12	1	12	5.5445
8	Type 5	14	0.8571429	12	5.5515
9	Type 5	8	1.5	12	5.5335
10	Type 5	17	0.7058824	12	5.5585
11	Type 5	19	0.6315789	12	5.5645
12	Type 5	15	0.8	12	5.5515
13	Type 5	12	1	12	5.5425
14	Type 5	19	0.6315789	12	5.5645
15	Type 5	14	0.8571429	12	5.5495
16	Type 5	20	0.6	12	5.5685
17	Type 5	12	1	12	5.5445
18	Type 5	14	0.8571429	12	5.5485
19	Type 5	12	1	12	5.5435
20	Type 5	16	0.75	12	5.5565
21	Type 5	12	1	12	5.5425
22	Type 5	20	0.6	12	5.5675
23	Type 5	14	0.8571429	12	5.5495
24	Type 5	13	0.9230769	12	5.5455
25	Type 5	8	1.5	12	5.5325
26	Type 5	17	0.7058824	12	5.5575
27	Type 5	19	0.6315789	12	5.5655
28	Type 5	12	1	12	5.5445
29	Type 5	18	0.6666667	12	5.5615

Radar Signal 6							
Trial ID	Radar Type	Pulse Width (us)	PRI (us)	Pulses per Hop	Hopping Rate (kHz)	Hopping Sequence Length (ms)	Number of Pulses
0	Type 6	1	333.3	9	0.3333	300	16
1	Type 6	1	333.3	9	0.3333	300	10
2	Type 6	1	333.3	9	0.3333	300	14
3	Type 6	1	333.3	9	0.3333	300	19
4	Type 6	1	333.3	9	0.3333	300	15
5	Type 6	1	333.3	9	0.3333	300	18
6	Type 6	1	333.3	9	0.3333	300	14
7	Type 6	1	333.3	9	0.3333	300	14
8	Type 6	1	333.3	9	0.3333	300	21
9	Type 6	1	333.3	9	0.3333	300	15
10	Type 6	1	333.3	9	0.3333	300	16
11	Type 6	1	333.3	9	0.3333	300	24
12	Type 6	1	333.3	9	0.3333	300	13
13	Type 6	1	333.3	9	0.3333	300	20
14	Type 6	1	333.3	9	0.3333	300	17
15	Type 6	1	333.3	9	0.3333	300	20
16	Type 6	1	333.3	9	0.3333	300	16
17	Type 6	1	333.3	9	0.3333	300	18
18	Type 6	1	333.3	9	0.3333	300	14
19	Type 6	1	333.3	9	0.3333	300	16
20	Type 6	1	333.3	9	0.3333	300	20
21	Type 6	1	333.3	9	0.3333	300	19
22	Type 6	1	333.3	9	0.3333	300	23
23	Type 6	1	333.3	9	0.3333	300	17
24	Type 6	1	333.3	9	0.3333	300	16
25	Type 6	1	333.3	9	0.3333	300	13
26	Type 6	1	333.3	9	0.3333	300	13
27	Type 6	1	333.3	9	0.3333	300	18
28	Type 6	1	333.3	9	0.3333	300	19
29	Type 6	1	333.3	9	0.3333	300	20

8.4. Channel Availability Check Time

If the UUT successfully detected the radar burst, it should be observed as the UUT has no transmissions occurred until the UUT starts transmitting on another channel.

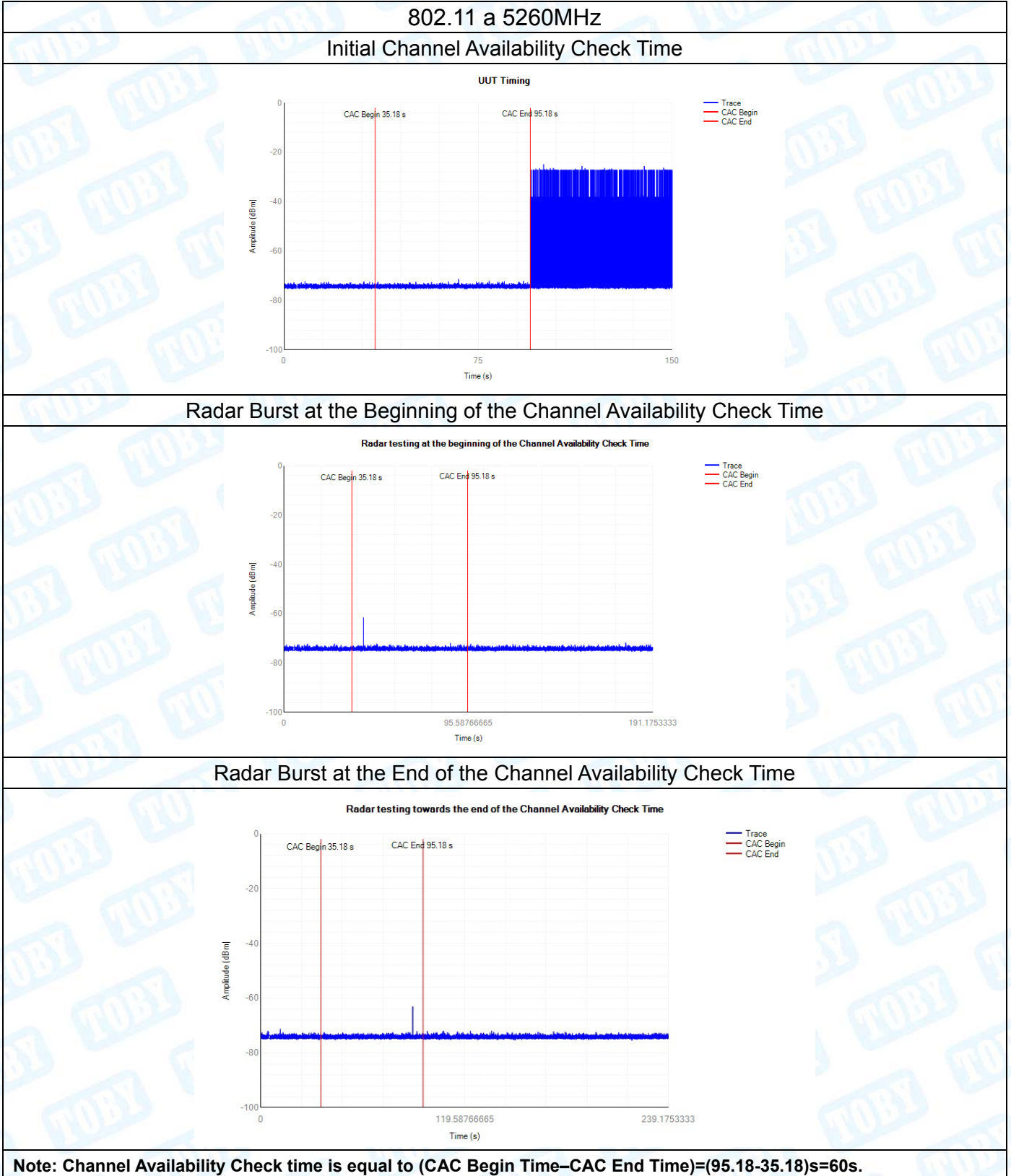

802.11 a 5500MHz

Initial Channel Availability Check Time

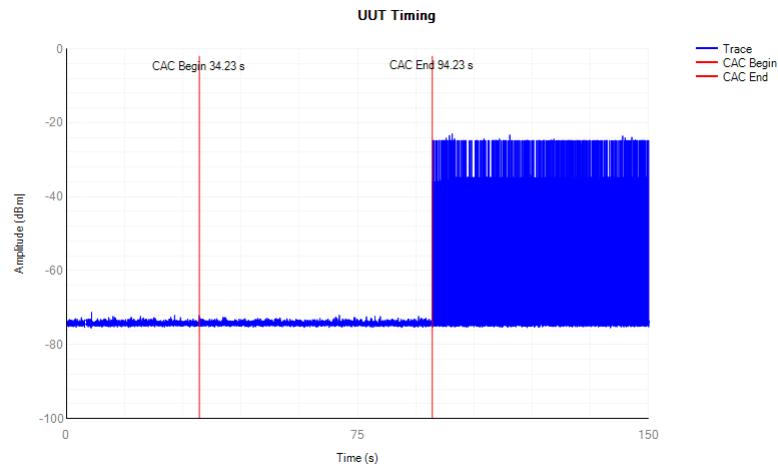

Radar Burst at the Beginning of the Channel Availability Check Time

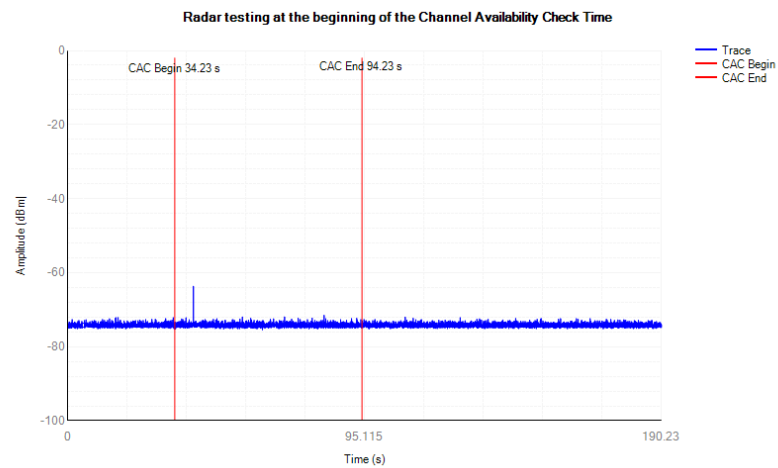

Radar Burst at the End of the Channel Availability Check Time

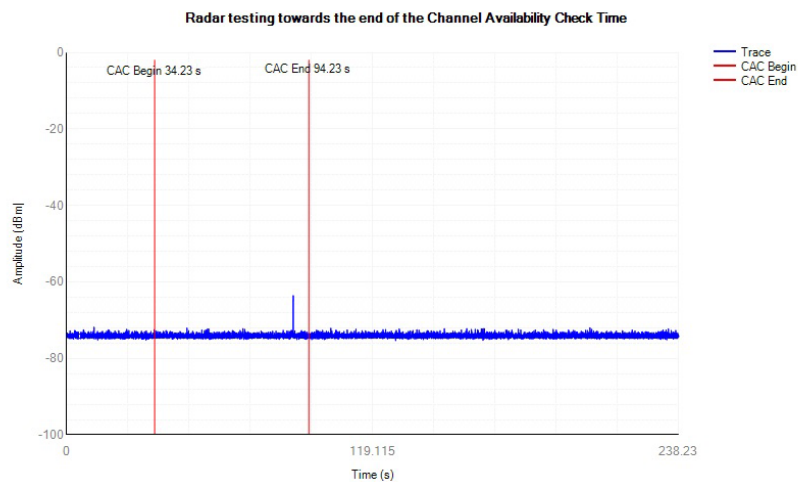

Note: Channel Availability Check time is equal to (CAC Begin Time-CAC End Time)=(94.23-34.23)s=60s.

802.11 n(HT40) 5270MHz

Initial Channel Availability Check Time

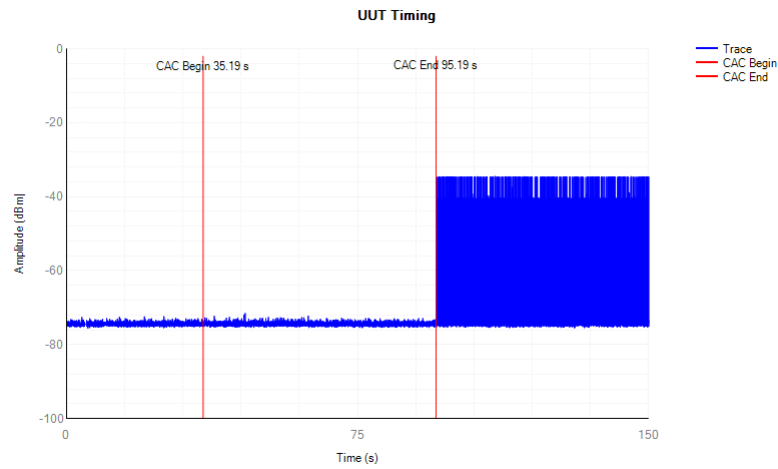

Radar Burst at the Beginning of the Channel Availability Check Time

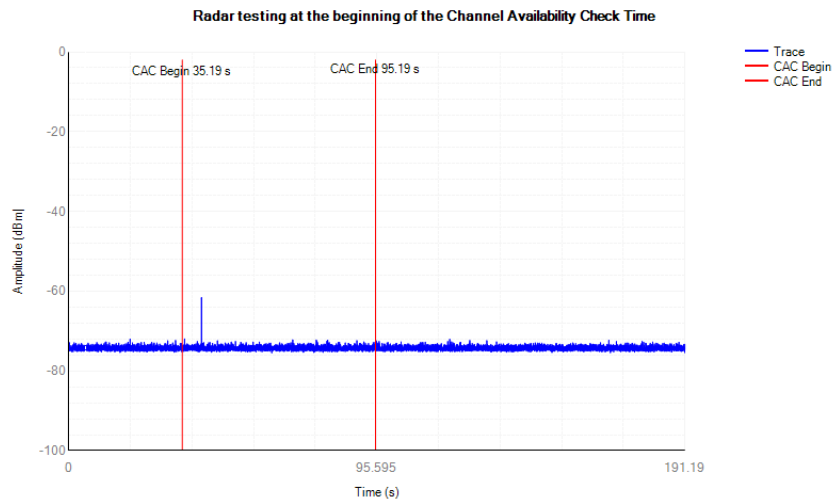

Radar Burst at the End of the Channel Availability Check Time

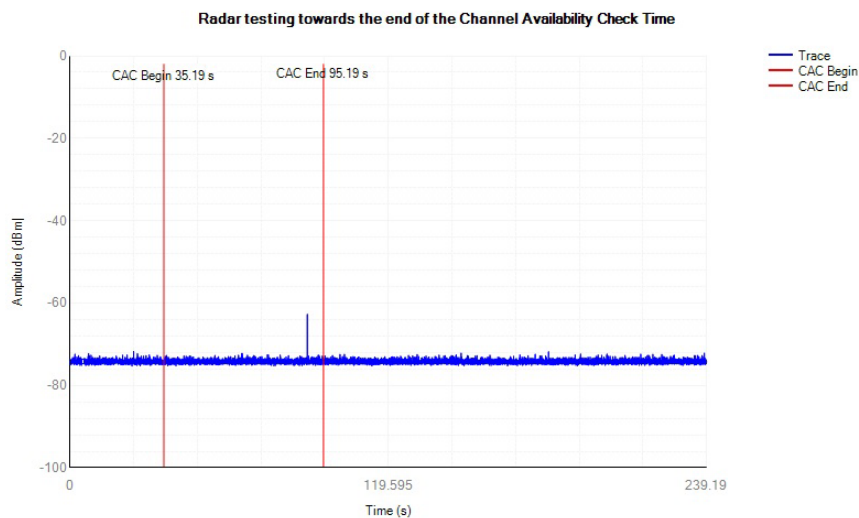

Note: Channel Availability Check time is equal to (CAC Begin Time-CAC End Time)=(95.19-35.19)s=60s.

802.11 n(HT40) 5510MHz

Initial Channel Availability Check Time

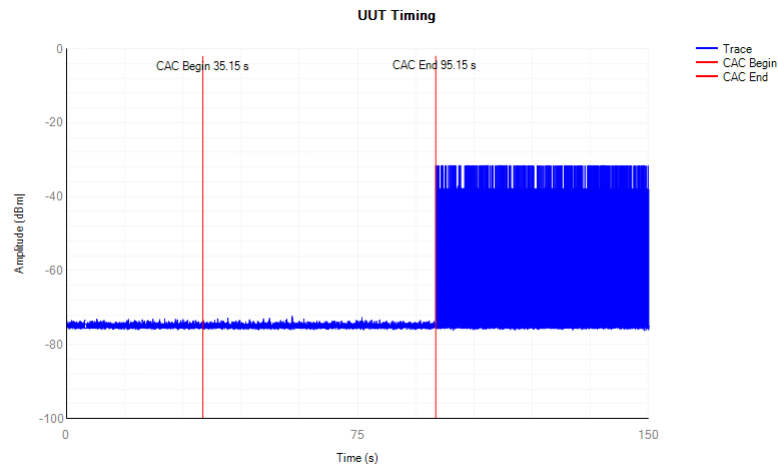

Radar Burst at the Beginning of the Channel Availability Check Time

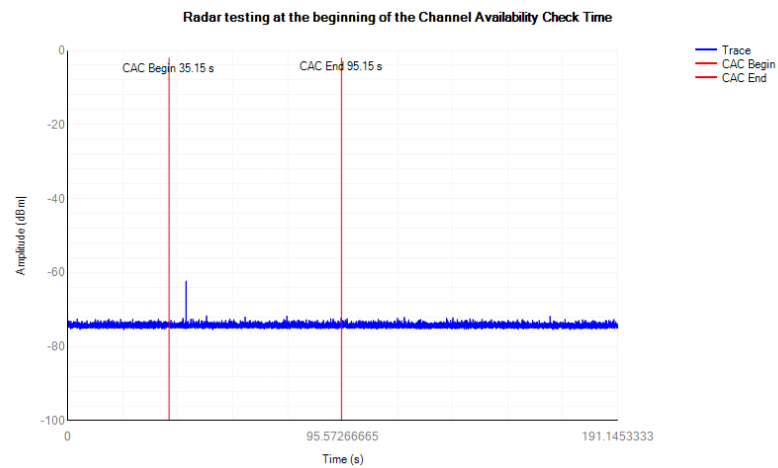

Radar Burst at the End of the Channel Availability Check Time

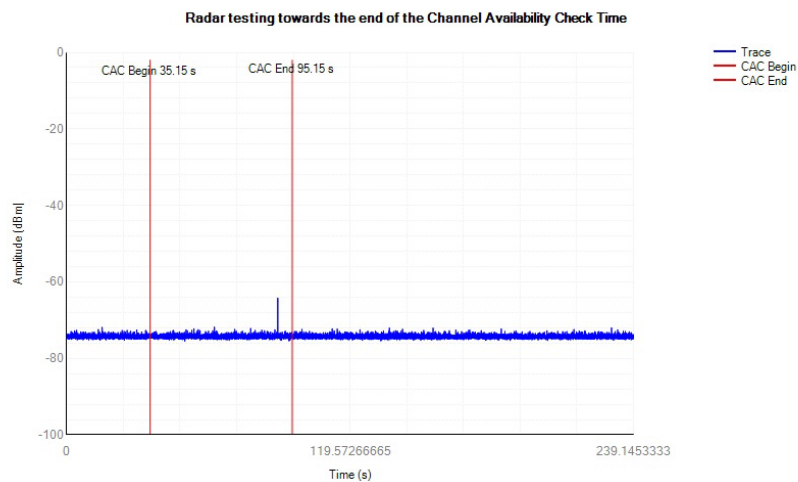

Note: Channel Availability Check time is equal to (CAC Begin Time–CAC End Time)=(95.15-35.15)s=60s.

802.11 ac(VHT80) 5290MHz

Initial Channel Availability Check Time

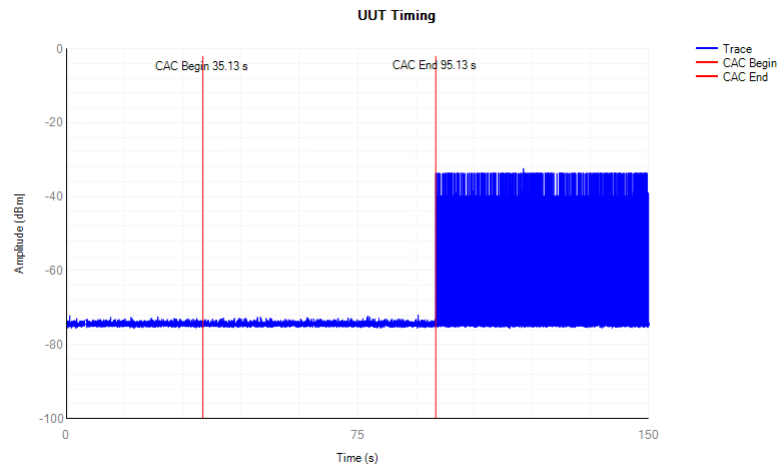

Radar Burst at the Beginning of the Channel Availability Check Time

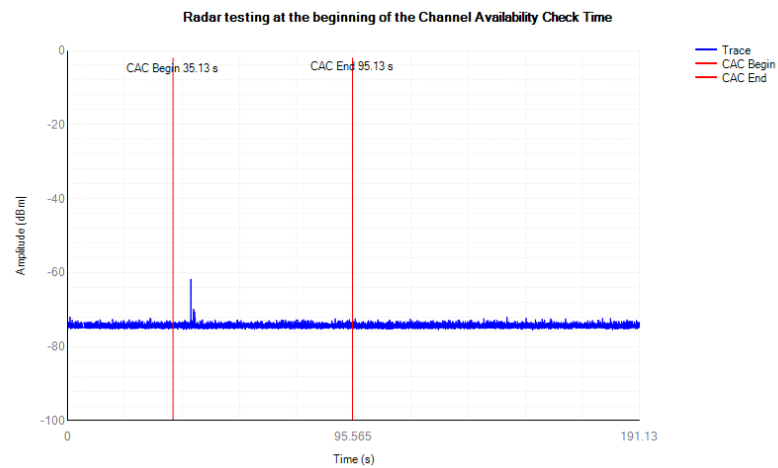

Radar Burst at the End of the Channel Availability Check Time

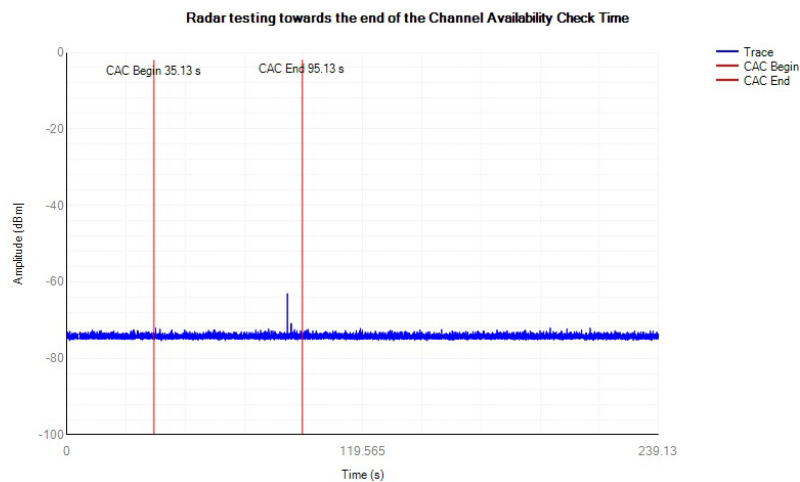

Note: Channel Availability Check time is equal to (CAC Begin Time-CAC End Time)=(95.13-35.13)s=60s.

802.11 ac(VHT80) 5530MHz

Initial Channel Availability Check Time

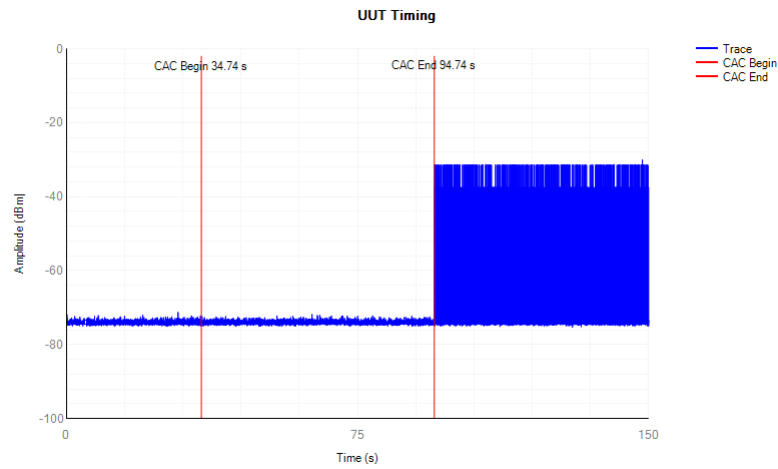

Radar Burst at the Beginning of the Channel Availability Check Time

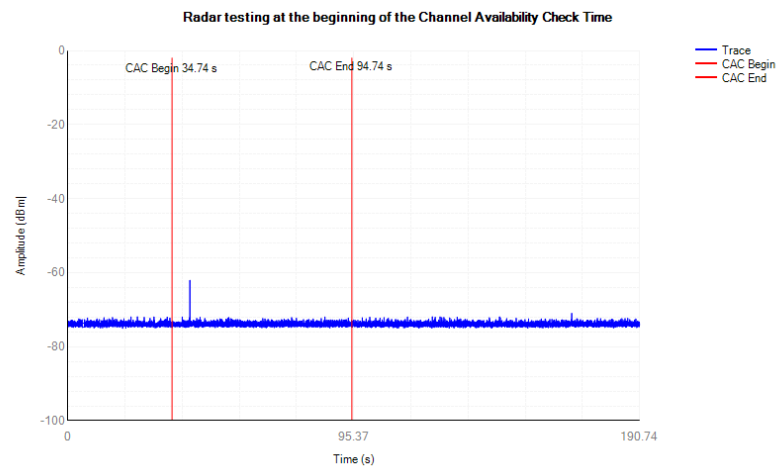

Radar Burst at the End of the Channel Availability Check Time

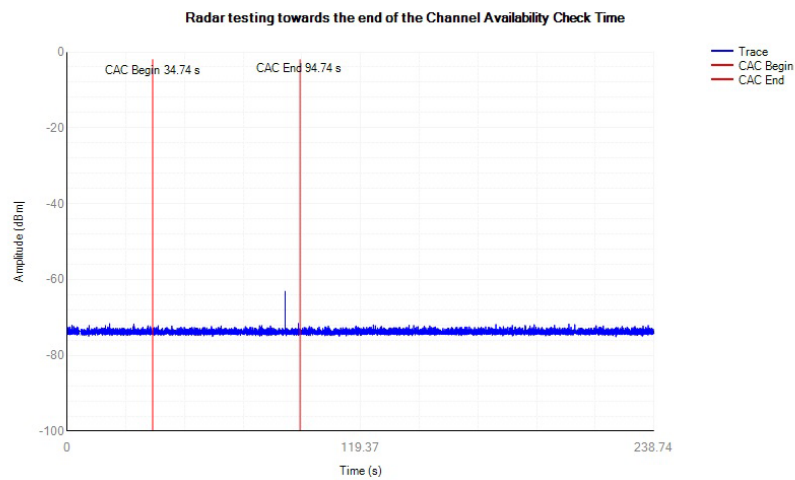

Note: Channel Availability Check time is equal to (CAC Begin Time–CAC End Time)=(94.74-34.74)s=60s.

8.5. In-Service(Pd)

802.11a 5260MHz									
Short Pulse Radar Test Waveforms									
Radar Type	Pulse Width (µsec)	PRI (µsec)		Number of Pulses	Pass times	Fail times	Percentage of Successful Detection (%)		Limit (%)
1	1	Test A: 15 unique PRI values randomly selected from the list of 23 PRI values in Table 5a		$\text{Roundup} \left\{ \left(\frac{1}{360} \right) \cdot \left(\frac{19 \cdot 10^6}{\text{PRI}_{\mu\text{sec}}} \right) \right\}$	30	0	100		60
		Test B: 15 unique PRI values randomly selected within the range of 518-3066 µsec, with a minimum increment of 1 µsec, excluding PRI values selected in Test A							
2	1-5	150-230		23-29	30	0	100		60
3	6-10	200-500		16-18	30	0	100		60
4	11-20	200-500		12-16	30	0	100		60
Aggregate (Radar Types 1-4)					120	0	100		80
Long Pulse Radar Test Waveform									
Radar Type	Pulse Width (µsec)	Chirp Width (MHz)	PRI (µsec)	Number of Pulses Per Burst	Number of Bursts	Pass times	Fail times	Percentage of Successful Detection (%)	Limit (%)
5	50-100	5-20	1000-2000	1-3	8-20	29	1	97	80
Frequency Hopping Radar Test Waveform									
Radar Type	Pulse Width (µsec)	PRI (µsec)	Pulses per Hop	Hopping Rate (kHz)	Hopping Sequence Length (msec)	Pass times	Fail times	Percentage of Successful Detection (%)	Limit (%)
6	1	333	9	0.333	300	30	0	100	70

802.11a 5500MHz									
Short Pulse Radar Test Waveforms									
Radar Type	Pulse Width (µsec)	PRI (µsec)		Number of Pulses	Pass times	Fail times	Percentage of Successful Detection (%)	Limit (%)	
1	1	Test A: 15 unique PRI values randomly selected from the list of 23 PRI values in Table 5a		Roundup $\left\{ \begin{matrix} \left(\frac{1}{360} \right) \\ \frac{19 \cdot 10^6}{PRI_{\mu\text{sec}}} \end{matrix} \right\}$	30	0	100	60	
		Test B: 15 unique PRI values randomly selected within the range of 518-3066 µsec, with a minimum increment of 1 µsec, excluding PRI values selected in Test A							
2	1-5	150-230		23-29	30	0	100	60	
3	6-10	200-500		16-18	30	0	100	60	
4	11-20	200-500		12-16	30	0	100	60	
Aggregate (Radar Types 1-4)					120	0	100	80	
Long Pulse Radar Test Waveform									
Radar Type	Pulse Width (µsec)	Chirp Width (MHz)	PRI (µsec)	Number of Pulses Per Burst	Number of Bursts	Pass times	Fail times	Percentage of Successful Detection (%)	Limit (%)
5	50-100	5-20	1000-2000	1-3	8-20	29	1	97	80
Frequency Hopping Radar Test Waveform									
Radar Type	Pulse Width (µsec)	PRI (µsec)	Pulses per Hop	Hopping Rate (kHz)	Hopping Sequence Length (msec)	Pass times	Fail times	Percentage of Successful Detection (%)	Limit (%)
6	1	333	9	0.333	300	27	3	90	70

802.11n (HT40) 5270MHz									
Short Pulse Radar Test Waveforms									
Radar Type	Pulse Width (µsec)	PRI (µsec)		Number of Pulses	Pass times	Fail times	Percentage of Successful Detection (%)	Limit (%)	
1	1	Test A: 15 unique PRI values randomly selected from the list of 23 PRI values in Table 5a		$\text{Roundup} \left\{ \begin{array}{l} \left(\frac{1}{360} \right) \\ \left(\frac{19 \cdot 10^6}{\text{PRI}_{\mu\text{sec}}} \right) \end{array} \right\}$	30	0	100	60	
		Test B: 15 unique PRI values randomly selected within the range of 518-3066 µsec, with a minimum increment of 1 µsec, excluding PRI values selected in Test A							
2	1-5	150-230		23-29	30	0	100	60	
3	6-10	200-500		16-18	30	0	100	60	
4	11-20	200-500		12-16	30	0	100	60	
Aggregate (Radar Types 1-4)					120	0	100	80	
Long Pulse Radar Test Waveform									
Radar Type	Pulse Width (µsec)	Chirp Width (MHz)	PRI (µsec)	Number of Pulses Per Burst	Number of Bursts	Pass times	Fail times	Percentage of Successful Detection (%)	Limit (%)
5	50-100	5-20	1000-2000	1-3	8-20	30	0	100	80
Frequency Hopping Radar Test Waveform									
Radar Type	Pulse Width (µsec)	PRI (µsec)	Pulses per Hop	Hopping Rate (kHz)	Hopping Sequence Length (msec)	Pass times	Fail times	Percentage of Successful Detection (%)	Limit (%)
6	1	333	9	0.333	300	30	0	100	70

802.11n (HT40) 5510MHz									
Short Pulse Radar Test Waveforms									
Radar Type	Pulse Width (µsec)	PRI (µsec)		Number of Pulses	Pass times	Fail times	Percentage of Successful Detection (%)	Limit (%)	
1	1	Test A: 15 unique PRI values randomly selected from the list of 23 PRI values in Table 5a		$\text{Roundup} \left\{ \begin{matrix} \left(\frac{1}{360} \right) \\ \frac{19 \cdot 10^6}{\text{PRI}_{\mu\text{sec}}} \end{matrix} \right\}$	30	0	100	60	
		Test B: 15 unique PRI values randomly selected within the range of 518-3066 µsec, with a minimum increment of 1 µsec, excluding PRI values selected in Test A							
2	1-5	150-230		23-29	30	0	100	60	
3	6-10	200-500		16-18	30	0	100	60	
4	11-20	200-500		12-16	30	0	100	60	
Aggregate (Radar Types 1-4)					120	0	100	80	
Long Pulse Radar Test Waveform									
Radar Type	Pulse Width (µsec)	Chirp Width (MHz)	PRI (µsec)	Number of Pulses Per Burst	Number of Bursts	Pass times	Fail times	Percentage of Successful Detection (%)	Limit (%)
5	50-100	5-20	1000-2000	1-3	8-20	30	0	100	80
Frequency Hopping Radar Test Waveform									
Radar Type	Pulse Width (µsec)	PRI (µsec)	Pulses per Hop	Hopping Rate (kHz)	Hopping Sequence Length (msec)	Pass times	Fail times	Percentage of Successful Detection (%)	Limit (%)
6	1	333	9	0.333	300	26	4	87	70

802.11 ac(VHT80) 5290MHz									
Short Pulse Radar Test Waveforms									
Radar Type	Pulse Width (µsec)	PRI (µsec)		Number of Pulses	Pass times	Fail times	Percentage of Successful Detection (%)	Limit (%)	
1	1	Test A: 15 unique PRI values randomly selected from the list of 23 PRI values in Table 5a		$\text{Roundup} \left\{ \begin{matrix} \left(\frac{1}{360} \right) \\ \frac{19 \cdot 10^6}{\text{PRI}_{\mu\text{sec}}} \end{matrix} \right\}$	30	0	100	60	
		Test B: 15 unique PRI values randomly selected within the range of 518-3066 µsec, with a minimum increment of 1 µsec, excluding PRI values selected in Test A							
2	1-5	150-230		23-29	30	0	100	60	
3	6-10	200-500		16-18	30	0	100	60	
4	11-20	200-500		12-16	30	0	100	60	
Aggregate (Radar Types 1-4)					120	0	100	80	
Long Pulse Radar Test Waveform									
Radar Type	Pulse Width (µsec)	Chirp Width (MHz)	PRI (µsec)	Number of Pulses Per Burst	Number of Bursts	Pass times	Fail times	Percentage of Successful Detection (%)	Limit (%)
5	50-100	5-20	1000-2000	1-3	8-20	30	0	100	80
Frequency Hopping Radar Test Waveform									
Radar Type	Pulse Width (µsec)	PRI (µsec)	Pulses per Hop	Hopping Rate (kHz)	Hopping Sequence Length (msec)	Pass times	Fail times	Percentage of Successful Detection (%)	Limit (%)
6	1	333	9	0.333	300	29	1	97	70

802.11 ac(VHT80) 5530MHz									
Short Pulse Radar Test Waveforms									
Radar Type	Pulse Width (µsec)	PRI (µsec)		Number of Pulses	Pass times	Fail times	Percentage of Successful Detection (%)	Limit (%)	
1	1	Test A: 15 unique PRI values randomly selected from the list of 23 PRI values in Table 5a		$\text{Roundup} \left\{ \left(\frac{1}{360} \right) \cdot \left(\frac{19 \cdot 10^6}{\text{PRI}_{\mu\text{sec}}} \right) \right\}$	30	0	100	60	
		Test B: 15 unique PRI values randomly selected within the range of 518-3066 µsec, with a minimum increment of 1 µsec, excluding PRI values selected in Test A							
2	1-5	150-230		23-29	30	0	100	60	
3	6-10	200-500		16-18	30	0	100	60	
4	11-20	200-500		12-16	30	0	100	60	
Aggregate (Radar Types 1-4)					120	0	100	80	
Long Pulse Radar Test Waveform									
Radar Type	Pulse Width (µsec)	Chirp Width (MHz)	PRI (µsec)	Number of Pulses Per Burst	Number of Bursts	Pass times	Fail times	Percentage of Successful Detection (%)	Limit (%)
5	50-100	5-20	1000-2000	1-3	8-20	30	0	100	80
Frequency Hopping Radar Test Waveform									
Radar Type	Pulse Width (µsec)	PRI (µsec)	Pulses per Hop	Hopping Rate (kHz)	Hopping Sequence Length (msec)	Pass times	Fail times	Percentage of Successful Detection (%)	Limit (%)
6	1	333	9	0.333	300	29	1	97	70

8.6. Channel Move Time and Channel Closing Transmission Time

Shutdown Time								
Mode	Frequency (MHz)	Channel Move Time (s)	Limit Channel Move Time (s)	Close Transmission Time (s)	Limit Close Transmission Time (s)	Close Transmission Time after 200ms(s)	Limit Close Transmission Time after 200ms (s)	Verdict
802.11 a	5260	0.7244	10	0.0384	0.26	0.0096	0.06	Pass

5260MHz 802.11 a Shutdown

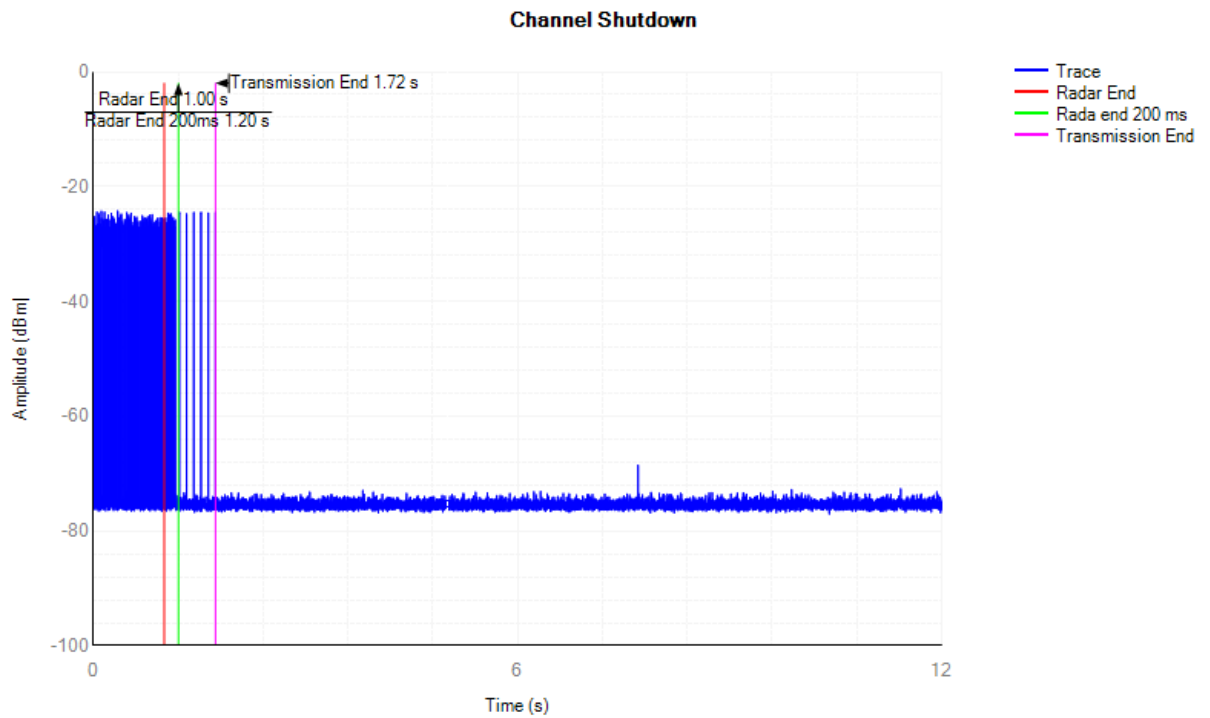

Shutdown Time

Mode	Frequency (MHz)	Channel Move Time (s)	Limit Channel Move Time (s)	Close Transmission Time (s)	Limit Close Transmission Time (s)	Close Transmission Time after 200ms(s)	Limit Close Transmission Time after 200ms (s)	Verdict
802.11 n(HT40)	5270	0.7244	10	0.0384	0.26	0.0096	0.06	Pass

5270MHz 802.11 n(HT40) Shutdown

Channel Shutdown

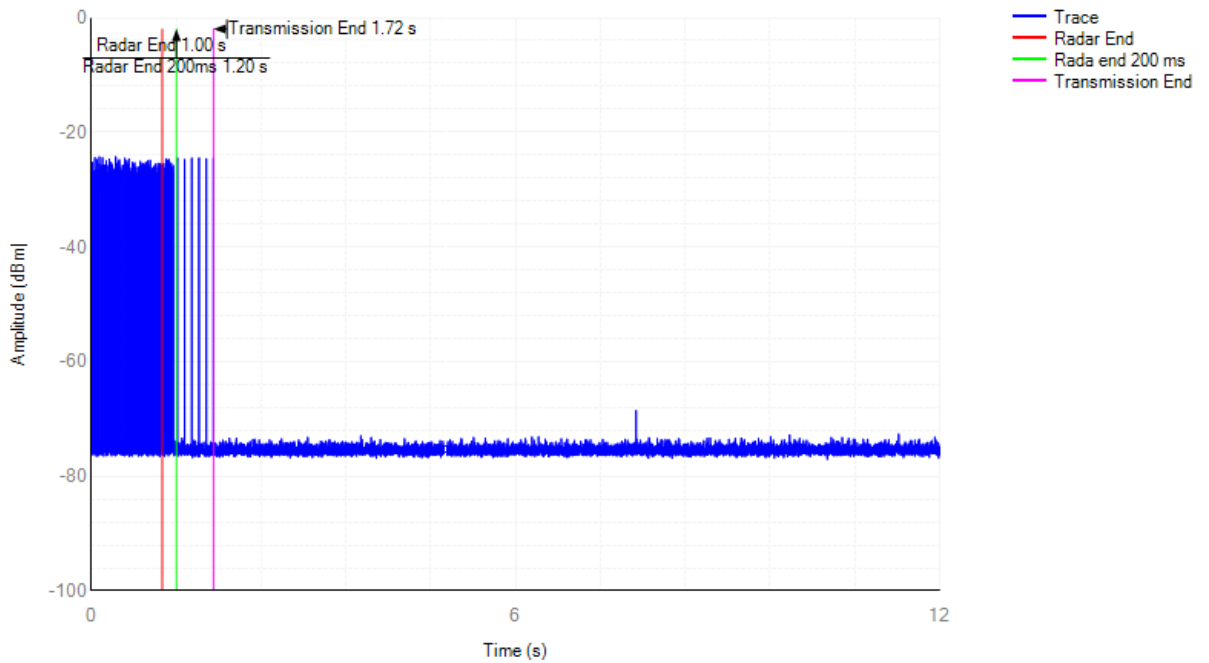

Shutdown Time

Mode	Frequency (MHz)	Channel Move Time (s)	Limit Channel Move Time (s)	Close Transmission Time (s)	Limit Close Transmission Time (s)	Close Transmission Time after 200ms(s)	Limit Close Transmission Time after 200ms (s)	Verdict
802.11 ac(VHT80)	5290	0.7156	10	0.014	0.26	0.0048	0.06	Pass

5290MHz 802.11 ac(VHT80) Shutdown

Channel Shutdown

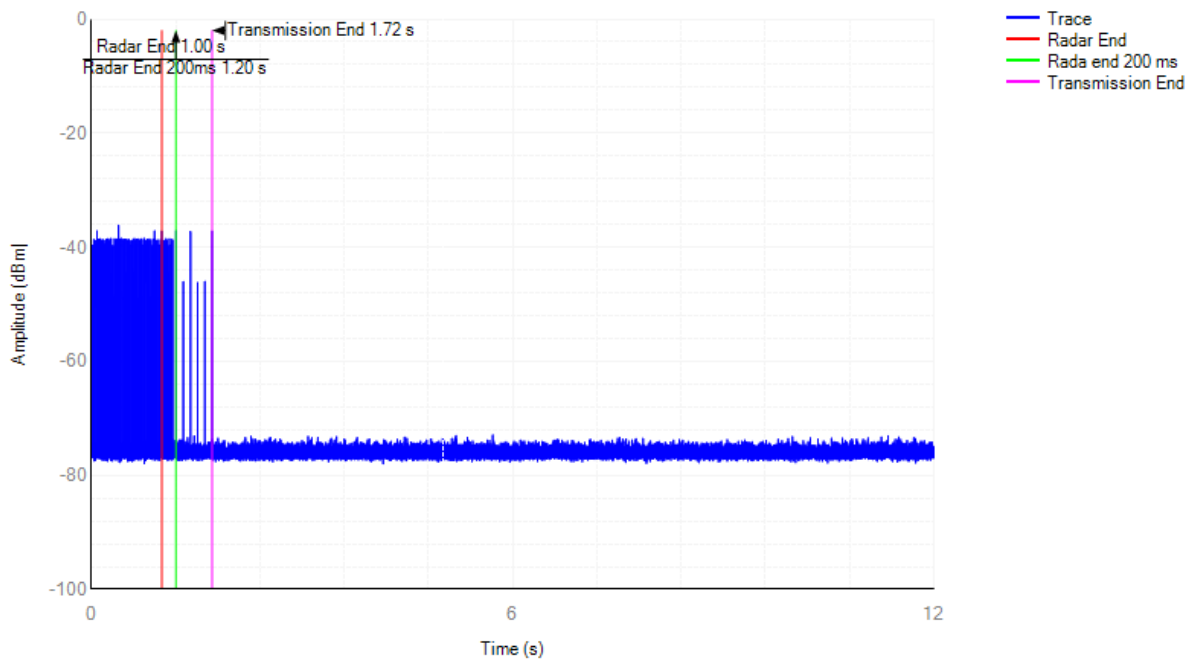

Shutdown Time

Mode	Frequency (MHz)	Channel Move Time (s)	Limit Channel Move Time (s)	Close Transmission Time (s)	Limit Close Transmission Time (s)	Close Transmission Time after 200ms(s)	Limit Close Transmission Time after 200ms (s)	Verdict
802.11 a	5500	0.6932	10	0.012	0.26	0.004	0.06	Pass

5500MHz 802.11 a Shutdown

Channel Shutdown

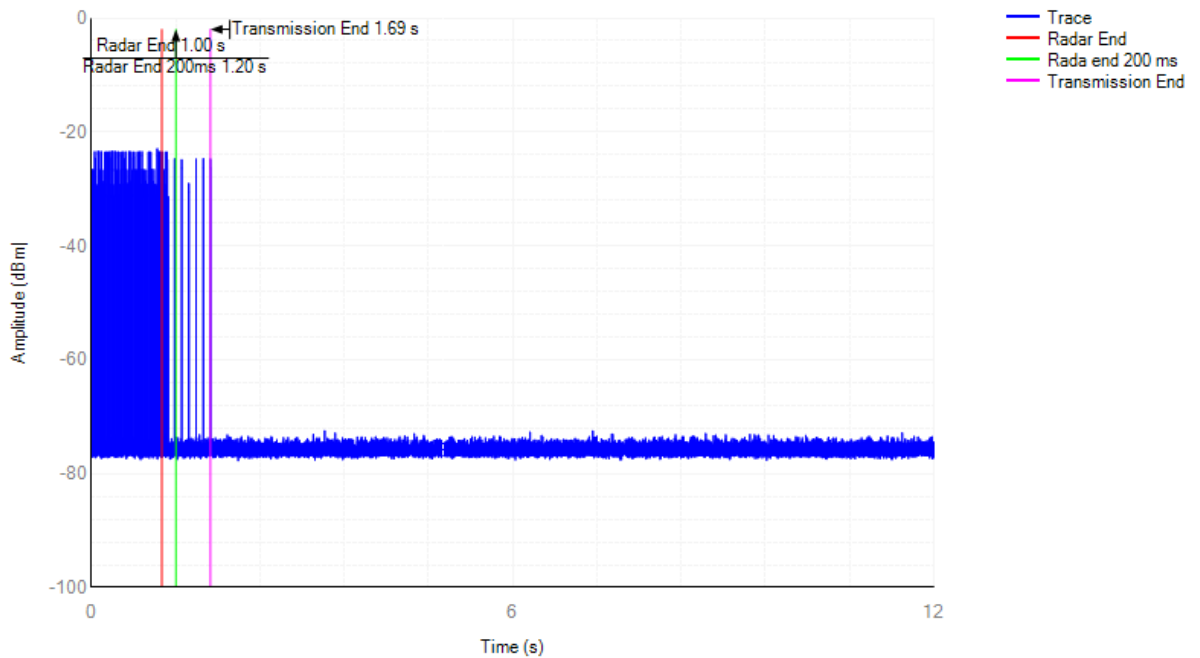

Shutdown Time

Mode	Frequency (MHz)	Channel Move Time (s)	Limit Channel Move Time (s)	Close Transmission Time (s)	Limit Close Transmission Time (s)	Close Transmission Time after 200ms(s)	Limit Close Transmission Time after 200ms (s)	Verdict
802.11 n(HT40)	5510	0.6872	10	0.0132	0.26	0.004	0.06	Pass

5510MHz 802.11 n(HT40) Shutdown

Channel Shutdown

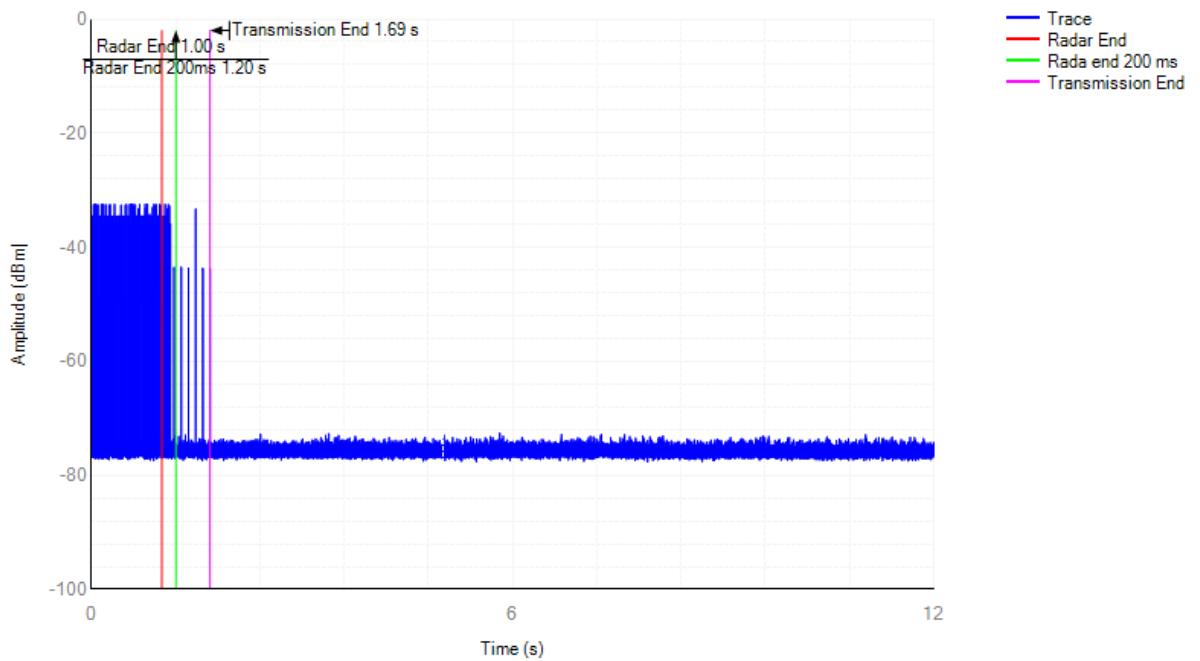

Shutdown Time

Mode	Frequency (MHz)	Channel Move Time (s)	Limit Channel Move Time (s)	Close Transmission Time (s)	Limit Close Transmission Time (s)	Close Transmission Time after 200ms(s)	Limit Close Transmission Time after 200ms (s)	Verdict
802.11 ac(VHT80)	5530	0.7844	10	0.0456	0.26	0.0108	0.06	Pass

530MHz 802.11 ac(VHT80) Shutdown

Channel Shutdown

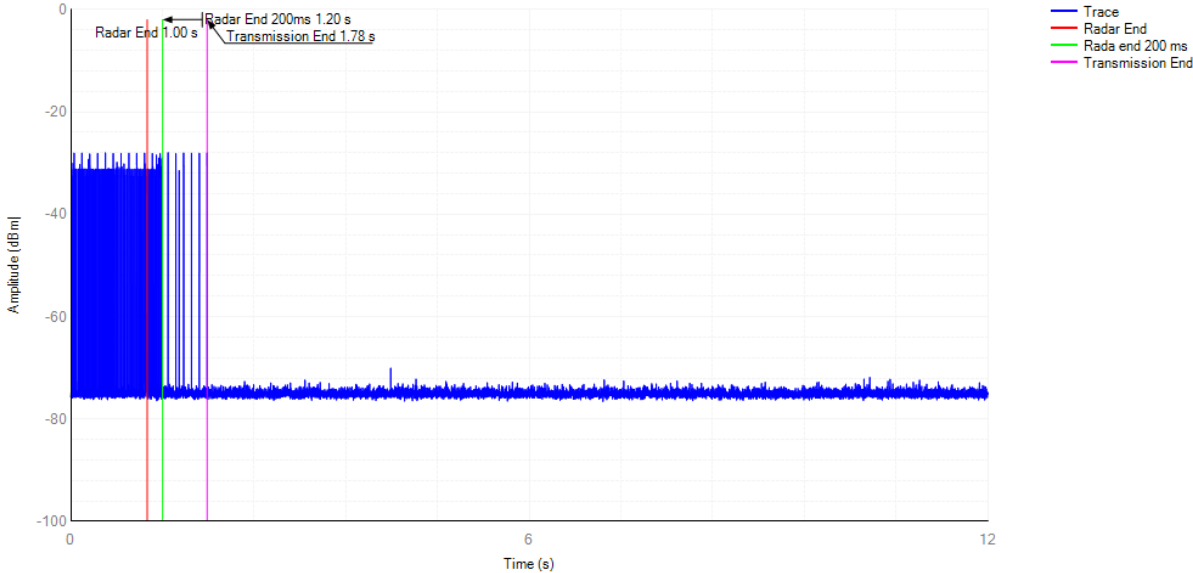

8.7. Non-occupancy Period

During the 30 minutes observation time, UUT did not make any transmissions on a channel after a radar signal was detected on that channel by either the Channel Availability Check or the In-Service Monitoring.

Non-Occupancy Period Result				
Modulation Mode	Freq. (MHz)	Non-Occupancy Period		
		Measured	Limit	Result
ac(VHT80)	5290	>30min	30min	Complied
	5530	>30min	30min	Complied

11ac 80MHz Mode 5290MHz

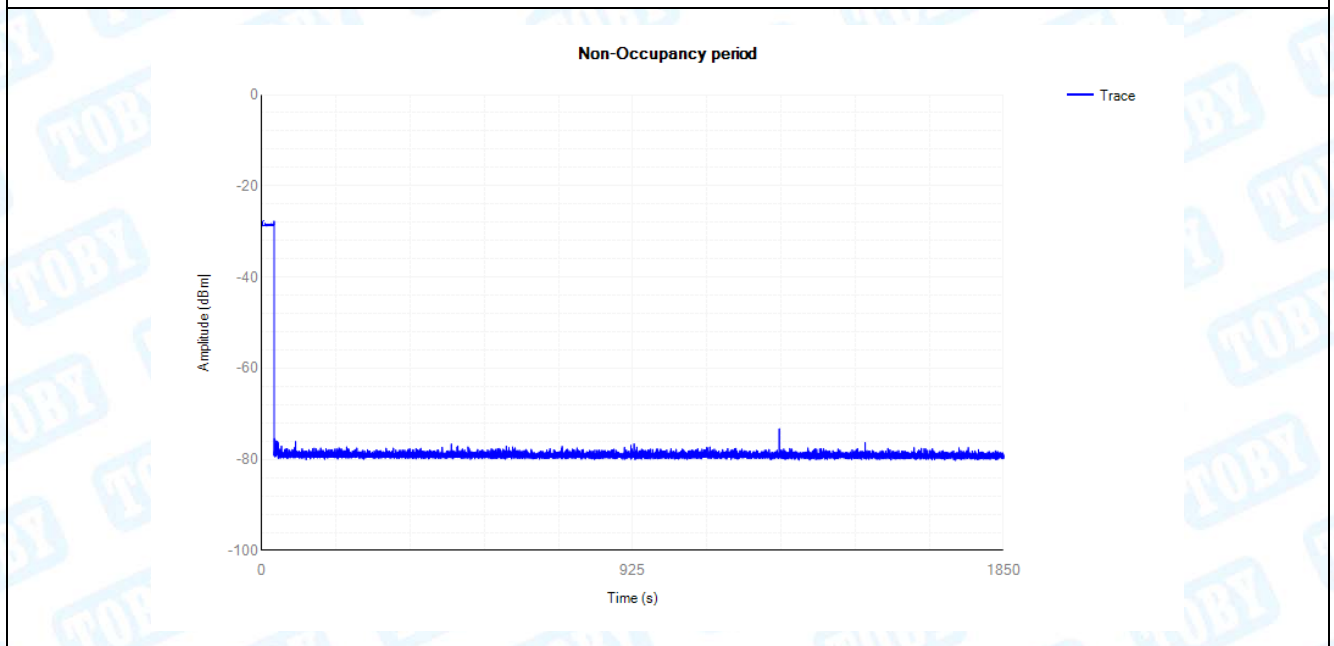

11ac 80MHz Mode 5530MHz

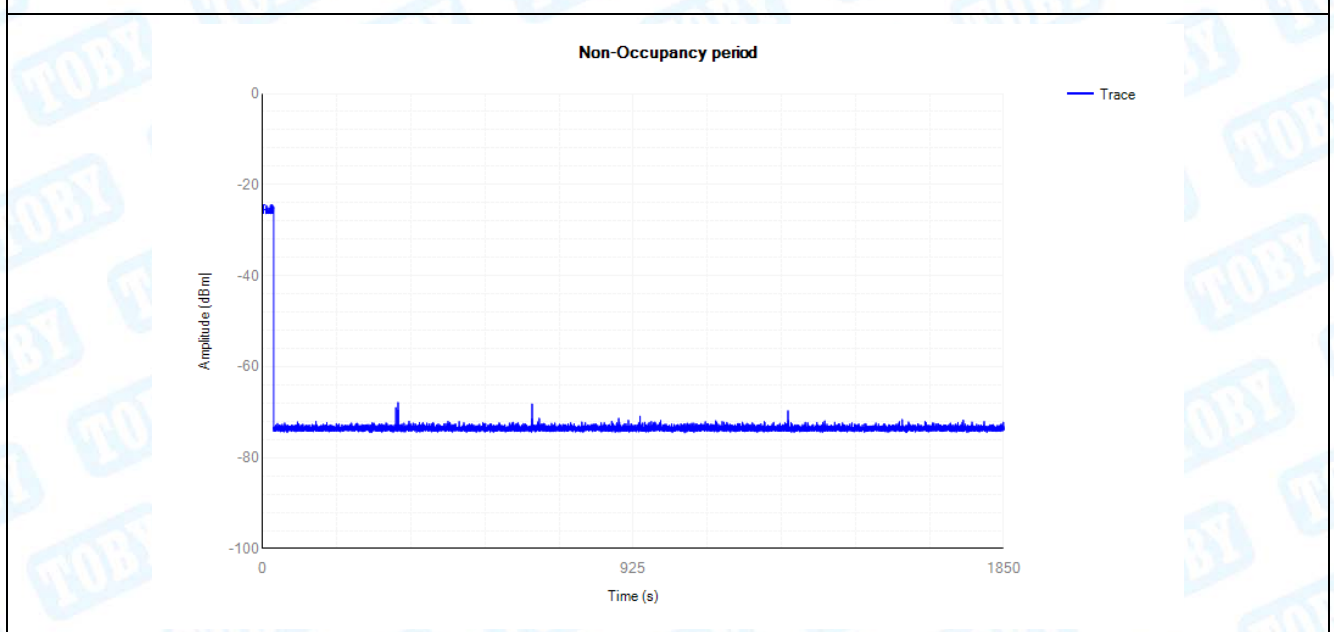

8.8. Uniform Spreading

The intention of the uniform spreading is to provide, on aggregate, a uniform loading of the spectrum. The UUT using the bands 5250 to 5350MHz and 5470 to 5600 MHz channels so that the probability of selecting a given channel shall be the same for channels. The UUT will select channel by random mode and remember this channel when detect radar signal, so that will select unused channel by random mode.

8.9. U-NII Detection Bandwidth

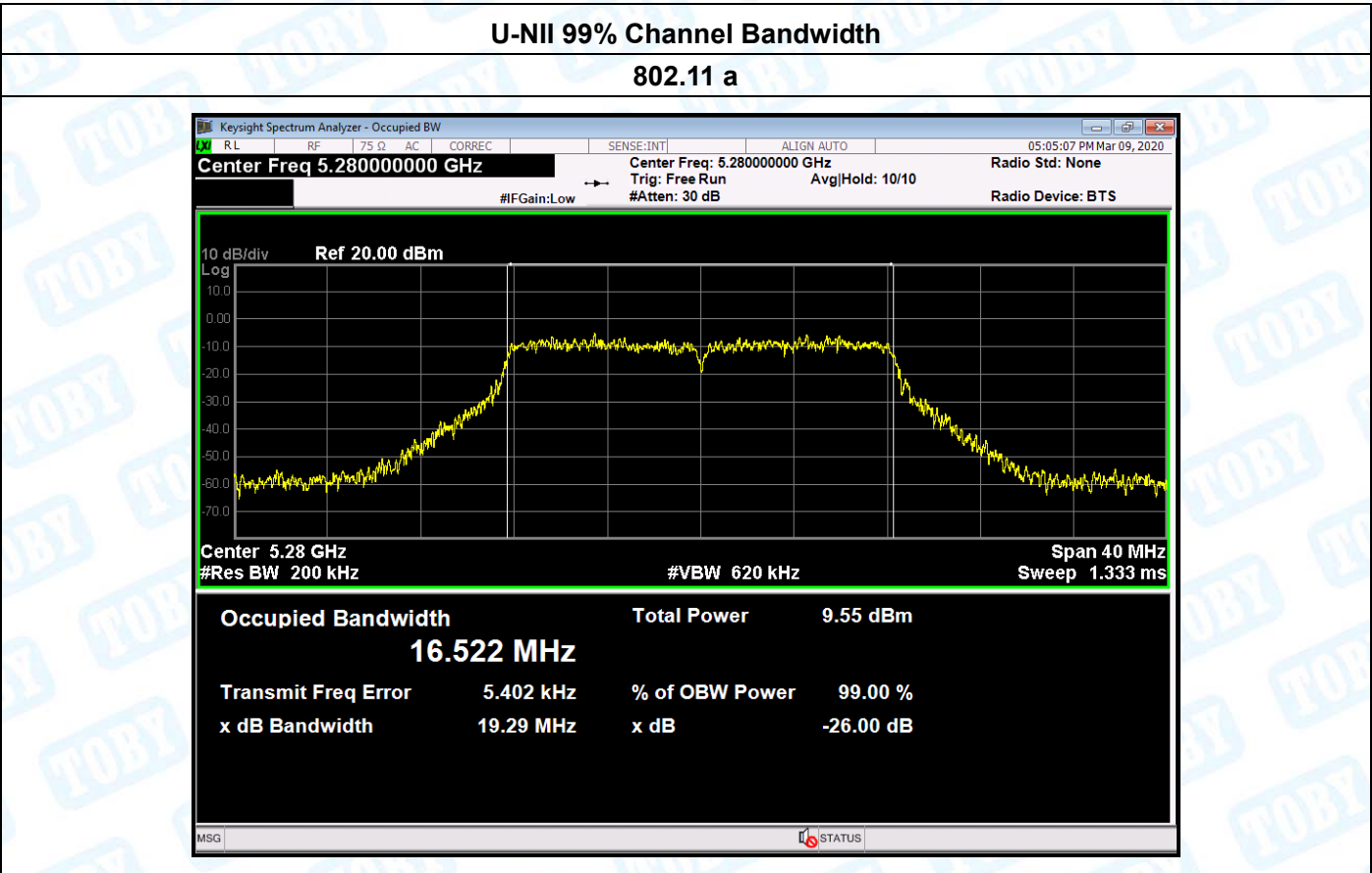

802.11 n(HT40)

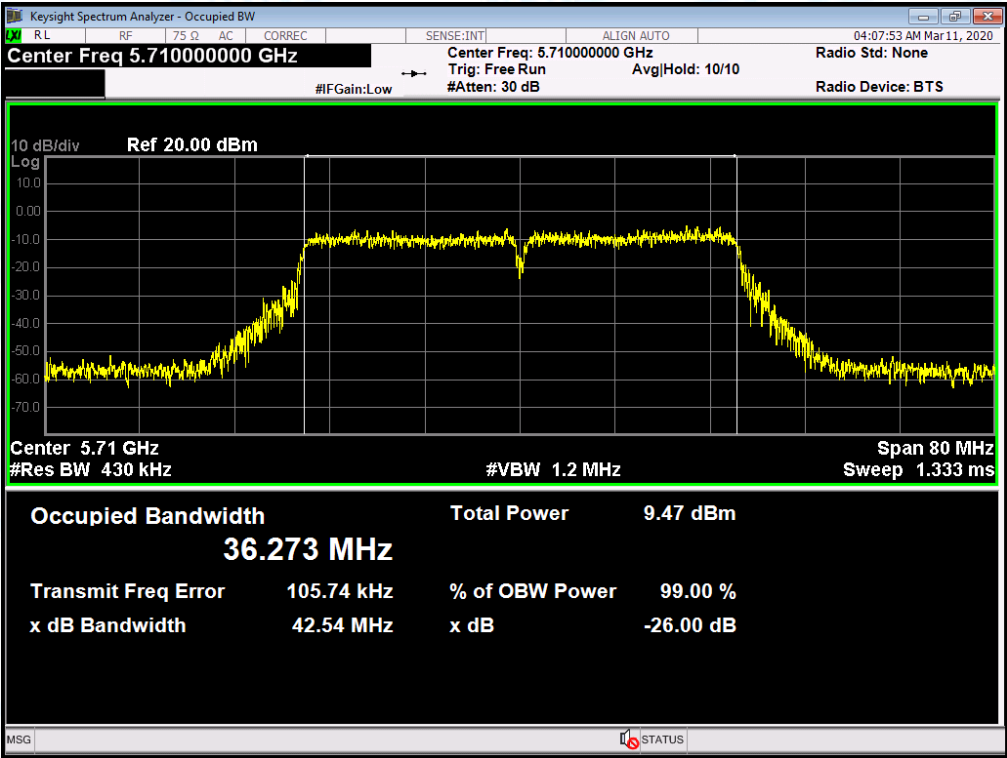

802.11 ac(VHT80)

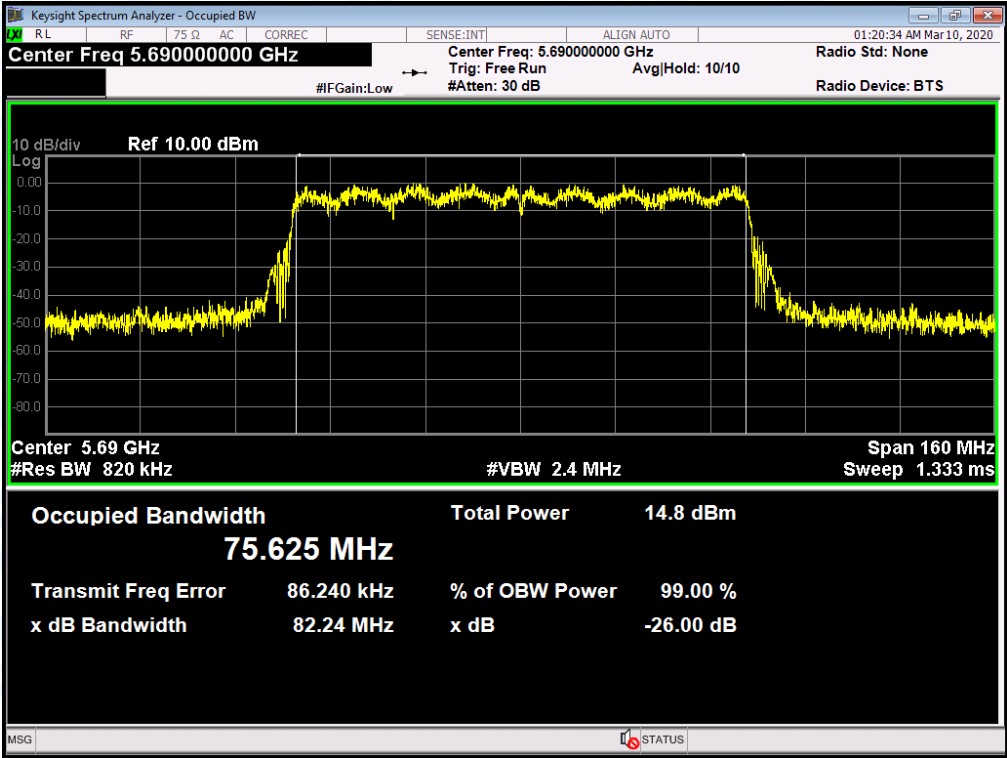

Note: the 99% OBW of U-NII Detection Bandwidth only used the worst data of 802.11 a/n(HT40)/ac(VHT80).

Detection Bandwidth Test Transmission 20M												
EUT Frequency:		802.11 a 5260MHz										
Test Radar Type:		Type 0										
Detection Bandwidth Limit(100% of the UNII 99% power bandwidth):										16.552MHz		
Detection Bandwidth 5269(FH)-5251(FL)MHz:							18MHz					
Test Result:		PASS										
Radar Fre.: (MHz)	DFS Detection Trials (1=Detection, 0= No Detection)										Detection Rate (%)	Limit (%)
	1	2	3	4	5	6	7	8	9	10		
5250	1	0	1	1	1	1	1	1	1	1	90	90
5251(FL)	1	1	1	1	1	1	1	1	1	1	100	90
5252	1	1	1	1	1	1	1	1	1	1	100	90
5253	1	1	1	1	1	1	1	1	1	1	100	90
5254	1	1	1	1	1	1	1	1	1	1	100	90
5255	1	1	1	1	1	1	1	1	1	1	100	90
5256	1	1	1	1	1	1	1	1	1	1	100	90
5257	1	1	1	1	1	1	1	1	1	1	100	90
5258	1	1	1	1	1	1	1	1	1	1	100	90
5259	1	1	1	1	1	1	1	1	1	1	100	90
5260	1	1	1	1	1	1	1	1	1	1	100	90
5261	1	1	1	1	1	1	1	1	1	1	100	90
5262	1	1	1	1	1	1	1	1	1	1	100	90
5263	1	1	1	1	1	1	1	1	1	1	100	90
5264	1	1	1	1	1	1	1	1	1	1	100	90
5265	1	1	1	1	1	1	1	1	1	1	100	90
5266	1	1	1	1	1	1	1	1	1	1	100	90
5267	1	1	1	1	1	1	1	1	1	1	100	90
5268	1	1	1	1	1	1	1	1	1	1	100	90
5269(FH)	1	1	1	1	1	1	1	1	1	1	100	90
5270	1	1	1	1	0	1	1	1	1	1	90	90

Detection Bandwidth Test Transmission 20M												
EUT Frequency:		802.11 a 5500MHz										
Test Radar Type:		Type 0										
Detection Bandwidth Limit(100% of the UNII 99% power bandwidth):										16.552MHz		
Detection Bandwidth 5509(FH)-5491(FL)MHz:							18MHz					
Test Result:		PASS										
Radar Fre.: (MHz)	DFS Detection Trials (1=Detection, 0= No Detection)										Detection Rate (%)	Limit (%)
	1	2	3	4	5	6	7	8	9	10		
5490	1	1	1	1	0	1	1	1	1	1	90	90
5491(FL)	1	1	1	1	1	1	1	1	1	1	100	90
5492	1	1	1	1	1	1	1	1	1	1	100	90
5493	1	1	1	1	1	1	1	1	1	1	100	90
5494	1	1	1	1	1	1	1	1	1	1	100	90
5495	1	1	1	1	1	1	1	1	1	1	100	90
5496	1	1	1	1	1	1	1	1	1	1	100	90
5497	1	1	1	1	1	1	1	1	1	1	100	90
5498	1	1	1	1	1	1	1	1	1	1	100	90
5499	1	1	1	1	1	1	1	1	1	1	100	90
5500	1	1	1	1	1	1	1	1	1	1	100	90
5501	1	1	1	1	1	1	1	1	1	1	100	90
5502	1	1	1	1	1	1	1	1	1	1	100	90
5503	1	1	1	1	1	1	1	1	1	1	100	90
5504	1	1	1	1	1	1	1	1	1	1	100	90
5505	1	1	1	1	1	1	1	1	1	1	100	90
5506	1	1	1	1	1	1	1	1	1	1	100	90
5507	1	1	1	1	1	1	1	1	1	1	100	90
5508	1	1	1	1	1	1	1	1	1	1	100	90
5509(FH)	1	1	1	1	1	1	1	1	1	1	100	90
5510	1	1	1	1	1	1	1	1	1	1	100	90

Detection Bandwidth Test Transmission 40M												
EUT Frequency:		802.11 n(HT40) 5270MHz										
Test Radar Type:		Type 0										
Detection Bandwidth Limit(100% of the UNII 99% power bandwidth):										36.273MHz		
Detection Bandwidth 5289(FH)-5251(FL)MHz:							38MHz					
Test Result:		PASS										
Radar Fre.: (MHz)	DFS Detection Trials (1=Detection, 0= No Detection)										Detection Rate (%)	Limit (%)
	1	2	3	4	5	6	7	8	9	10		
5250	1	1	1	0	1	1	1	1	1	1	90	90
5251(FL)	1	1	0	1	1	1	1	1	1	1	90	90
5252	1	1	1	1	1	1	1	1	1	1	100	90
5253	1	1	1	1	1	1	1	1	1	1	100	90
5254	1	1	1	1	1	1	1	1	1	1	100	90
5255	1	1	1	1	1	1	1	1	1	1	100	90
5256	1	1	1	1	1	1	1	1	1	1	100	90
5257	1	1	1	1	1	1	1	1	1	1	100	90
5258	1	1	1	1	1	1	1	1	1	1	100	90
5259	1	1	1	1	1	1	1	1	1	1	100	90
5260	1	1	1	1	1	1	1	1	1	1	100	90
5261	1	1	1	1	1	1	1	1	1	1	100	90
5262	1	1	1	1	1	1	1	1	1	1	100	90
5263	1	1	1	1	1	1	1	1	1	1	100	90
5264	1	1	1	1	1	1	1	1	1	1	100	90
5265	1	1	1	1	1	1	1	1	1	1	100	90
5266	1	1	1	1	1	1	1	1	1	1	100	90
5267	1	1	1	1	1	1	1	1	1	1	100	90
5268	1	1	1	1	1	1	1	1	1	1	100	90
5269	1	1	1	1	1	1	1	1	1	1	100	90
5270	1	1	1	1	1	1	1	1	1	1	100	90
5271	1	1	1	1	1	1	1	1	1	1	100	90
5272	1	1	1	1	1	1	1	1	1	1	100	90
5273	1	1	1	1	1	1	1	1	1	1	100	90
5274	1	1	1	1	1	1	1	1	1	1	100	90
5275	1	1	1	1	1	1	1	1	1	1	100	90
5276	1	1	1	1	1	1	1	1	1	1	100	90

5277	1	1	1	1	1	1	1	1	1	1	100	90
5278	1	1	1	1	1	1	1	1	1	1	100	90
5279	1	1	1	1	1	1	1	1	1	1	100	90
5280	1	1	1	1	1	1	1	1	1	1	100	90
5281	1	1	1	1	1	1	1	1	1	1	100	90
5282	1	1	1	1	1	1	1	1	1	1	100	90
5283	1	1	1	1	1	1	1	1	1	1	100	90
5284	1	1	1	1	1	1	1	1	1	1	100	90
5285	1	1	1	1	1	1	1	1	1	1	100	90
5286	1	1	1	1	1	1	1	1	1	1	100	90
5287	1	1	1	1	1	1	1	1	1	1	100	90
5288	1	1	1	1	1	1	1	1	1	1	100	90
5289(FH)	1	1	1	1	1	1	1	1	1	1	100	90
5290	1	1	1	1	1	1	0	1	1	1	90	90

Detection Bandwidth Test Transmission 40M												
EUT Frequency:	802.11 n(HT40) 5510MHz											
Test Radar Type:	Type 0											
Detection Bandwidth Limit(100% of the UNII 99% power bandwidth):	36.273MHz											
Detection Bandwidth 5529(FH)-5491(FL)MHz:	38MHz											
Test Result:	PASS											
Radar Fre.: (MHz)	DFS Detection Trials (1=Detection, 0= No Detection)										Detection Rate (%)	Limit (%)
	1	2	3	4	5	6	7	8	9	10		
5490	1	1	1	1	1	0	1	1	1	1	90	90
5491(FL)	1	1	1	1	1	1	1	1	1	1	100	90
5492	1	1	1	1	1	1	1	1	1	1	100	90
5493	1	1	1	1	1	1	1	1	1	1	100	90
5494	1	1	1	1	1	1	1	1	1	1	100	90
5495	1	1	1	1	1	1	1	1	1	1	100	90
5496	1	1	1	1	1	1	1	1	1	1	100	90
5497	1	1	1	1	1	1	1	1	1	1	100	90
5498	1	1	1	1	1	1	1	1	1	1	100	90
5499	1	1	1	1	1	1	1	1	1	1	100	90
5500	1	1	1	1	1	1	1	1	1	1	100	90
5501	1	1	1	1	1	1	1	1	1	1	100	90
5520	1	1	1	1	1	1	1	1	1	1	100	90
5503	1	1	1	1	1	1	1	1	1	1	100	90
5504	1	1	1	1	1	1	1	1	1	1	100	90
5505	1	1	1	1	1	1	1	1	1	1	100	90
5506	1	1	1	1	1	1	1	1	1	1	100	90
5507	1	1	1	1	1	1	1	1	1	1	100	90
5508	1	1	1	1	1	1	1	1	1	1	100	90
5509	1	1	1	1	1	1	1	1	1	1	100	90
5510	1	1	1	1	1	1	1	1	1	1	100	90
5511	1	1	1	1	1	1	1	1	1	1	100	90
5512	1	1	1	1	1	1	1	1	1	1	100	90
5513	1	1	1	1	1	1	1	1	1	1	100	90
5514	1	1	1	1	1	1	1	1	1	1	100	90
5515	1	1	1	1	1	1	1	1	1	1	100	90
5516	1	1	1	1	1	1	1	1	1	1	100	90

5517	1	1	1	1	1	1	1	1	1	1	100	90
5518	1	1	1	1	1	1	1	1	1	1	100	90
5519	1	1	1	1	1	1	1	1	1	1	100	90
5520	1	1	1	1	1	1	1	1	1	1	100	90
5521	1	1	1	1	1	1	1	1	1	1	100	90
5522	1	1	1	1	1	1	1	1	1	1	100	90
5523	1	1	1	1	1	1	1	1	1	1	100	90
5524	1	1	1	1	1	1	1	1	1	1	100	90
5525	1	1	1	1	1	1	1	1	1	1	100	90
5526	1	1	1	1	0	1	1	1	1	1	90	90
5527	1	1	1	1	1	1	1	1	1	1	100	90
5528	1	1	1	1	1	1	1	1	1	1	100	90
5529(FH)	1	1	1	1	1	1	1	1	1	1	100	90
5530	1	1	1	0	1	1	1	1	1	1	90	90

Detection Bandwidth Test Transmission 80M												
EUT Frequency:		802.11 ac(VHT80) 5290MHz										
Test Radar Type:		Type 0										
Detection Bandwidth Limit(100% of the UNII 99% power bandwidth):										75.625MHz		
Detection Bandwidth 5329(FH)-5251(FL)MHz:						78MHz						
Test Result:		PASS										
Radar Fre.: (MHz)	DFS Detection Trials (1=Detection, 0= No Detection)										Detection Rate (%)	Limit (%)
	1	2	3	4	5	6	7	8	9	10		
5250	1	1	1	1	1	1	0	1	1	1	90	90
5251(FL)	1	1	1	1	1	1	1	1	1	1	100	90
5252	1	1	1	1	1	1	1	1	1	1	100	90
5253	1	1	1	1	1	1	1	1	1	1	100	90
5254	1	1	1	1	1	1	1	1	1	1	100	90
5255	1	1	1	1	1	0	1	1	1	1	90	90
5256	1	1	1	1	1	1	1	1	1	1	100	90
5258	1	1	1	1	1	1	1	1	1	1	100	90
5259	1	1	1	1	1	1	1	1	1	1	100	90
5260	1	1	1	1	1	1	1	1	1	1	100	90
5261	1	1	1	1	1	1	1	1	1	1	100	90
5262	1	1	1	1	1	1	1	1	1	1	100	90
5263	1	1	1	1	1	1	1	1	1	1	100	90
5264	1	1	1	1	1	1	1	1	1	1	100	90
5265	1	1	1	1	1	1	1	1	1	1	100	90
5266	1	1	1	1	1	1	1	1	1	1	100	90
5267	1	1	1	1	1	1	1	1	1	1	100	90
5268	1	1	1	1	1	1	1	1	1	1	100	90
5269	1	1	1	1	1	1	1	1	1	1	100	90
5270	1	1	1	1	1	1	1	1	1	1	100	90
5271	1	1	1	1	1	1	1	1	1	1	100	90
5272	1	1	1	1	1	1	1	1	1	1	100	90
5273	1	1	1	1	1	1	1	1	1	1	100	90
5274	1	1	1	1	1	1	1	1	1	1	100	90
5275	1	1	1	1	1	1	1	1	1	1	100	90
5276	1	1	1	1	1	1	1	1	1	1	100	90
5277	1	1	1	1	1	1	1	1	1	1	100	90

5278	1	1	1	1	1	1	1	1	1	1	100	90
5279	1	1	1	1	1	1	1	1	1	1	100	90
5280	1	1	1	1	1	1	1	1	1	1	100	90
5281	1	1	1	1	1	1	1	1	1	1	100	90
5282	1	1	1	1	1	1	1	1	1	1	100	90
5283	1	1	1	1	1	1	1	1	1	1	100	90
5284	1	1	1	1	1	1	1	1	1	1	100	90
5285	1	1	1	1	1	1	1	1	1	1	100	90
5286	1	1	1	1	1	1	1	1	1	1	100	90
5287	1	1	1	1	1	1	1	1	1	1	100	90
5288	1	1	1	1	1	1	1	1	1	1	100	90
5289	1	1	1	1	1	1	1	1	1	1	100	90
5290	1	1	1	1	1	1	1	1	1	1	100	90
5291	1	1	1	1	1	1	1	1	1	1	100	90
5292	1	1	1	1	1	1	1	1	1	1	100	90
5293	1	1	1	1	1	1	1	1	1	1	100	90
5294	1	1	1	1	1	1	1	1	1	1	100	90
5295	1	1	1	1	1	1	1	1	1	1	100	90
5296	1	1	1	1	1	1	1	1	1	1	100	90
5297	1	1	1	1	1	1	1	1	1	1	100	90
5298	1	1	1	1	1	1	1	1	1	1	100	90
5299	1	1	1	1	1	1	1	1	1	1	100	90
5300	1	1	1	1	1	1	1	1	1	1	100	90
5301	1	1	1	1	1	1	1	1	1	1	100	90
5302	1	1	1	1	1	1	1	1	1	1	100	90
5303	1	1	1	1	1	1	1	1	1	1	100	90
5304	1	1	1	1	1	1	1	1	1	1	100	90
5305	1	1	1	1	1	1	1	1	1	1	100	90
5306	1	1	1	1	1	1	1	1	1	1	100	90
5307	1	1	1	1	1	1	1	1	1	1	100	90
5308	1	1	1	1	1	1	1	1	1	1	100	90
5309	1	1	1	1	1	1	1	1	1	1	100	90
5310	1	1	1	1	1	1	1	1	1	1	100	90
5311	1	1	1	1	1	1	1	1	1	1	100	90
5312	1	1	1	1	1	1	1	1	1	1	100	90
5313	1	1	1	1	1	1	1	1	1	1	100	90
5314	1	1	1	1	1	1	1	1	1	1	100	90

5315	1	1	1	1	1	1	1	1	1	1	100	90
5316	1	1	1	1	1	1	1	1	1	1	100	90
5317	1	1	1	1	1	1	1	1	1	1	100	90
5318	1	1	1	1	1	1	1	1	1	1	100	90
5319	1	1	1	1	1	1	1	1	1	1	100	90
5320	1	1	1	1	1	1	1	1	1	1	100	90
5321	1	1	1	1	1	1	1	1	1	1	100	90
5322	1	1	1	1	1	1	1	1	1	1	100	90
5323	1	1	1	1	1	1	1	1	1	1	100	90
5324	1	1	1	1	1	1	1	1	1	1	100	90
5325	1	1	1	1	1	1	1	1	1	1	100	90
5326	1	1	1	1	1	1	1	1	1	1	100	90
5327	1	1	1	1	1	1	1	1	1	1	100	90
5328	1	1	1	1	1	1	1	1	1	1	100	90
5329(FH)	1	1	1	1	1	1	1	1	1	1	100	90
5330	1	1	0	1	1	1	1	1	1	1	90	90

Detection Bandwidth Test Transmission 80M												
EUT Frequency:		802.11 ac(VHT80) 5530MHz										
Test Radar Type:		Type 0										
Detection Bandwidth Limit(100% of the UNII 99% power bandwidth):								75.625MHz				
Detection Bandwidth 5569(FH)-5491(FL)MHz:						78MHz						
Test Result:		PASS										
Radar Fre.: (MHz)	DFS Detection Trials (1=Detection, 0= No Detection)										Detection Rate (%)	Limit (%)
	1	2	3	4	5	6	7	8	9	10		
5490	1	1	1	0	1	1	1	1	1	1	90	90
5491(FL)	1	1	1	1	1	1	1	1	1	1	100	90
5492	1	1	1	1	1	1	1	1	1	1	100	90
5493	1	1	1	1	1	1	1	1	1	1	100	90
5494	1	1	1	1	1	1	1	1	1	1	100	90
5495	1	1	1	1	1	1	1	1	1	1	100	90
5496	1	1	1	1	1	1	1	1	1	1	100	90
5497	1	1	1	1	1	1	1	1	1	1	100	90
5498	1	1	1	1	1	1	1	1	1	1	100	90
5499	1	1	1	1	1	1	1	1	1	1	100	90
5500	1	1	1	1	1	1	1	1	1	1	100	90
5501	1	1	1	1	1	1	1	1	1	1	100	90
5502	1	1	1	1	1	1	1	1	1	1	100	90
5503	1	1	1	1	1	1	1	1	1	1	100	90
5504	1	1	1	1	1	1	1	1	1	1	100	90
5505	1	1	1	1	1	1	1	1	1	1	100	90
5506	1	1	1	1	1	1	1	1	1	1	100	90
5507	1	1	1	1	1	1	1	1	1	1	100	90
5508	1	1	1	1	1	1	1	1	1	1	100	90
5509	1	1	1	1	1	1	1	1	1	1	100	90
5510	1	1	1	1	1	1	1	1	1	1	100	90
5511	1	1	1	1	1	1	1	1	1	1	100	90
5512	1	1	1	1	1	1	1	1	1	1	100	90
5513	1	1	1	1	1	1	1	1	1	1	100	90
5514	1	1	1	1	1	1	1	1	1	1	100	90
5515	1	1	1	1	1	1	1	1	1	1	100	90
5516	1	1	1	1	1	1	1	1	1	1	100	90

5517	1	1	1	1	1	1	1	1	1	1	100	90
5518	1	1	1	1	1	1	1	1	1	1	100	90
5519	1	1	1	1	1	1	1	1	1	1	100	90
5520	1	1	1	1	1	1	1	1	1	1	100	90
5521	1	1	1	1	1	1	1	1	1	1	100	90
5522	1	1	1	1	1	1	1	1	1	1	100	90
5523	1	1	1	1	1	1	1	1	1	1	100	90
5524	1	1	1	1	1	1	1	1	1	1	100	90
5525	1	1	1	1	1	1	1	1	1	1	100	90
5526	1	1	1	1	1	1	1	1	1	1	100	90
5527	1	1	1	1	1	1	1	1	1	1	100	90
5528	1	1	1	1	1	1	1	1	1	1	100	90
5530	1	1	1	1	1	1	1	1	1	1	100	90
5531	1	1	1	1	1	1	1	1	1	1	100	90
5532	1	1	1	1	1	1	1	1	1	1	100	90
5533	1	1	1	1	1	1	1	1	1	1	100	90
5534	1	1	1	1	1	1	1	1	1	1	100	90
5535	1	1	1	1	1	1	1	1	1	1	100	90
5536	1	1	1	1	1	1	1	1	1	1	100	90
5537	1	1	1	1	1	1	1	1	1	1	100	90
5538	1	1	1	1	1	1	1	1	1	1	100	90
5539	1	1	1	1	1	1	1	1	1	1	100	90
5540	1	1	1	1	1	1	1	1	1	1	100	90
5541	1	1	1	1	1	1	1	1	1	1	100	90
5542	1	1	1	1	1	1	1	1	1	1	100	90
5543	1	1	1	1	1	1	1	1	1	1	100	90
5544	1	1	1	1	1	1	1	1	1	1	100	90
5545	1	1	1	1	1	1	1	1	1	1	100	90
5546	1	1	1	1	1	1	1	1	1	1	100	90
5547	1	1	1	1	1	1	1	1	1	1	100	90
5548	1	1	1	1	1	1	1	1	1	1	100	90
5549	1	1	1	1	1	1	1	1	1	1	100	90
5550	1	1	1	1	1	1	1	1	1	1	100	90
5551	1	1	1	1	1	1	1	1	1	1	100	90
5552	1	1	1	1	1	1	1	1	1	1	100	90
5553	1	1	1	1	1	1	1	1	1	1	100	90
5554	1	1	0	1	1	1	1	1	1	1	90	90

5555	1	1	1	1	1	1	1	1	1	1	100	90
5556	1	1	1	1	1	1	1	1	1	1	100	90
5557	1	1	1	1	1	1	1	1	1	1	100	90
5558	1	1	1	1	1	1	1	1	1	1	100	90
5559	1	1	1	1	1	1	1	1	1	1	100	90
5560	1	1	1	1	1	1	1	1	1	1	100	90
5561	1	1	1	1	1	1	1	1	1	1	100	90
5562	1	1	1	1	1	1	1	1	1	1	100	90
5563	1	1	1	1	1	1	1	1	1	1	100	90
5564	1	1	1	1	1	1	1	1	1	1	100	90
5565	1	1	1	1	1	1	1	1	1	1	100	90
5566	1	1	1	1	1	1	1	1	1	1	100	90
5567	1	1	1	1	1	1	1	1	1	1	100	90
5568	1	1	1	1	1	1	1	1	1	1	100	90
5569(FH)	1	1	1	1	1	1	1	1	1	1	100	90
5570	1	1	1	1	1	1	1	1	1	1	100	90

----END OF REPORT-----