

MEASUREMENT REPORT

(FCC : Part 15 Subpart C (15.247) / ANSI C63.4-2009)



Testing Laboratory
1288

Product.....: Wireless Router
Trade Name.....: COMTREND
Model No.....: WR-6891u ; WAP-5891u
Applicant.....: COMTREND CORPORATION
Applicant Address.....: 3F-1, 10 Lane 609, Chung Hsin Road,
City 24159, Taiwan

Report Number	MLT1505P15002
Applicant	COMTREND CORPORATION
Product	Wireless Router
Sample Received Date	2015/5/8
Sample Tested Date	2015/5/8 ~ 2016/1/27

Report Prepared By	Jesse Tien
Signature	
Date Prepared	2016/2/1

Report Authorized By	Roger Chen
Signature	
Date Authorized	2016/2/1

Test By

Max Light Technology Co., Ltd.
 Room 5, 8F, No.125, Section 3 Roosevelt Road,
 Taipei, Taiwan., R.O.C.
 Office : Tel: 886-2-2363-2447 Fax: 886-2-2363-2597
 Lab. : Tel: 886-2-2663-3486 Fax: 886-2-2663-3582

It may be duplicated completely for legal use with the allowance of the applicant.
 It shall not be reproduced except in full, without the written approval of our
 laboratory.

Table of Contents :

History of Test Report -----	4
1. General -----	6
2. Conducted Emissions Requirements -----	12
3. Radiated Emissions Requirement -----	26
4. Maximum Conducted Output Power Requirements -----	41
5. Minimum 6dB RF Bandwidth Requirements -----	53
6. Maximum Power Density Requirements -----	64
7. Out of Band Conducted Spurious Emissions Requirements -----	70
8. Band Edges Requirement -----	90
9. Antenna Requirements -----	95
Appendix I - EUT Test Setup -----	96
Appendix II - Brand / Trade Name & Model No. Multiple Listee -----	97



History of Test Report

Original Report Issue Date: 2016/2/1

No additional attachment

Additional attachments were issued as in the following record:

Attachment No.	Issue Date	Description
MLT1505P15002	2016/2/1	Original report

CERTIFICATION

We here by verify that :

The test data, data evaluation, test procedures and equipment configurations shown in this report were made in accordance with the procedures given in ANSI C63.4-2009. All test were conducted by

MLT(Max Light Technology Co.,Ltd) Room 5, 8F, No.125, Section 3 Roosevelt Road, Taipei, Taiwan, R.O.C Also, we attest to the accuracy of each.

We further submit that the energy emitted by the sample EUT tested as described in the report is in compliance with Class B radiated and conducted emission limit of FCC Rules Part 15 Subpart C (15.247).

Applicant Name	COMTREND CORPORATION
Applicant Address	3F-1, 10 Lane 609, Chung Hsin Road, Section 5 San Chung District, New Taipei City 24159, Taiwan
Manufacturer Name	COMTREND CORPORATION
Manufacturer Address	3F-1, 10 Lane 609, Chung Hsin Road, Section 5 San Chung District, New Taipei City 24159, Taiwan

Equipment	Wireless Router
Model No	WR-6891u ; WAP-5891u
FCC ID	L9VWAP-5891U

Report Prepared By	Jesse Tien
Signature	

Report Authorized By	Roger Chen
Signature	

1. General

1.1 Introduction

The following measurement report is submitted on behalf of COMTREND CORPORATION In support of a Class B Digital Device certification in accordance with Part2 Subpart J and Part 15 Subpart C of the Commission's and Regulations.

1.2 Customer Details

Applicant Name	COMTREND CORPORATION
Applicant Address	3F-1, 10 Lane 609, Chung Hsin Road, Section 5 San Chung District, New Taipei City 24159, Taiwan
Manufacturer Name	COMTREND CORPORATION
Manufacturer Address	3F-1, 10 Lane 609, Chung Hsin Road, Section 5 San Chung District, New Taipei City 24159, Taiwan

1.3 Technical data of EUT

Equipment	Wireless Router
Model No	WR-6891u ; WAP-5891u
FCC ID	L9VWAP-5891U
Power Type	Model : UP0121M-12PA Input : AC100 - 240V , 50 / 60Hz , 0.4A Output : DC12V , 1.0A
Type of Modulation	CCK, DQPSK, DBPSK for DSSS 64QAM, 16QAM, QPSK, BPSK for OFDM
Transfer rate	802.11b: 11/ 5.5/ 2/ 1Mbps 802.11g: 54/ 48/ 36/ 24/ 18/ 12/ 9/ 6Mbps 802.11n HT20: 130, 117, 104, 78, 52, 39, 26, 13Mbps 802.11n HT40: 270, 243, 216, 162, 108, 81, 54, 27Mbps
Type of Antenna	Dipole Antenna
Frequency of Channel	See Next page

During testing the EUT was operated at Tx or Rx mode for each emission measured. This was done in order to ensure that maximum emission levels were attained.

802.11b & 802.11g & 802.11n HT20 Frequency of Each Channel (Working Frequency)

Channel No.	Frequency (MHz)
01	2412
02	2417
03	2422
04	2427
05	2432
06	2437
07	2442
08	2447
09	2452
10	2457
11	2462

802.11n HT40 Frequency of Each Channel (Working Frequency)

Channel No.	Frequency (MHz)
03	2422
04	2427
05	2432
06	2437
07	2442
08	2447
09	2452

1.4 Summary Of Tests

47 CFR Part 15 Subpart C			
Reference	Test	Results	Note
15.207	AC Power Conducted Emission	PASS	
15.209	Radiated Emission	PASS	
15.247(c)	Transmitter Radiated Emissions	PASS	
15.247(b)	Max. Output Power	PASS	
15.247(a)(2)	6dB RF Bandwidth	PASS	
15.247(d)	Max. Power Density	PASS	
15.247(c)	Out of Band Conducted Spurious Emission	PASS	
15.247(c)	Band Edge Measurement	PASS	
15.203	Antenna Requirement	PASS	

1.5 Description of Support Equipment

In order to construct the minimum system which required by the ANSI C63.4-2009, following equipments were used as the support units.

Component	Manufacturer	Model No.	Serial No.	FCC ID
Monitor	SONY	SDM-HS74	1356906	FCC DOC
Computer	HP	DX439AV	SGH5120HZM	FCC DOC
Keyboard	IBM	KB-0225	0059709	FCC DOC
Mouse	Dell	SAW34	LZE24773928	FCC DOC
Printer	HP	C4562B	H946151BZ	B94C2164X
Modem	D-Link	DFM-560EL	ES0025A000007	FCC DOC

1.6 Configuration of System Under Test

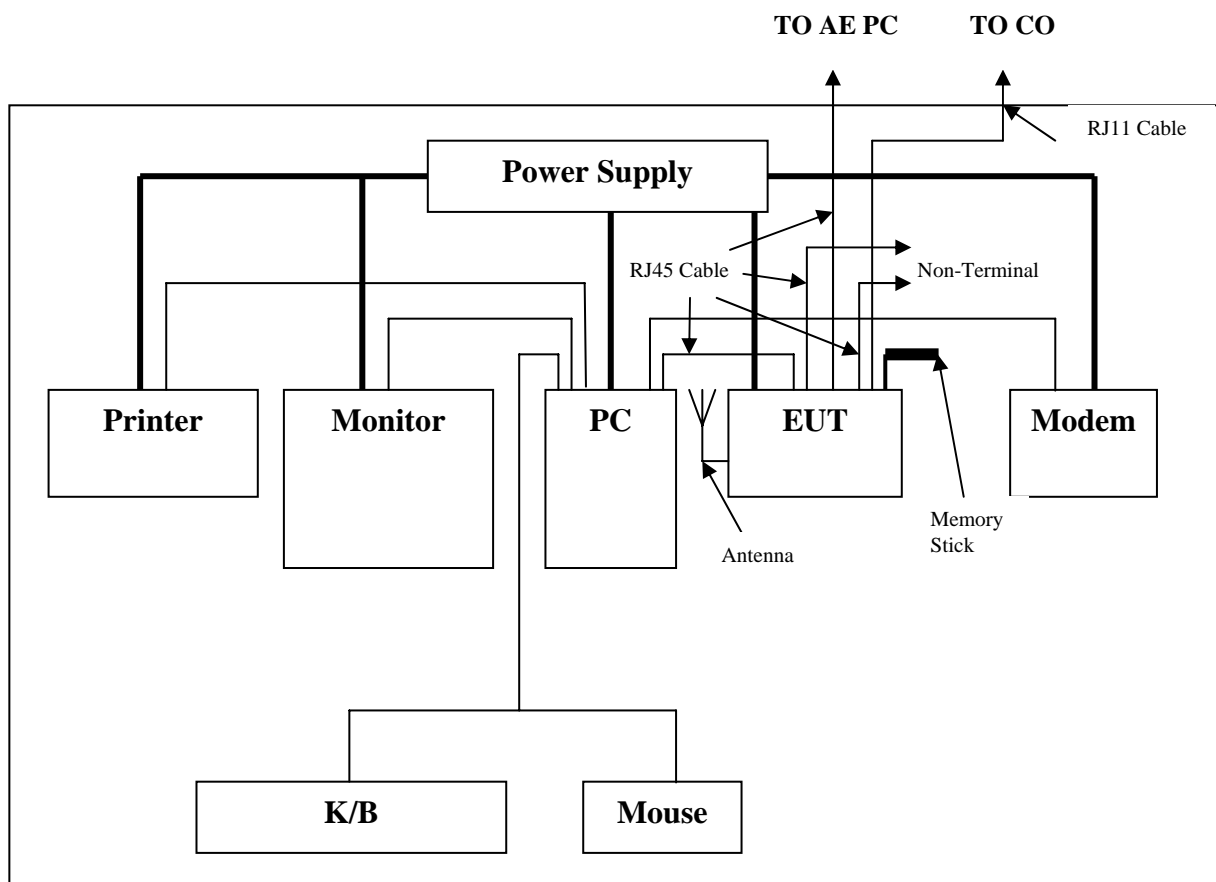

1.7 Test Procedure

All measurements contained in this report were performed according to the techniques described in Measurement procedure ANSI C63.4-2009 followed KDB 558074 v03r04 and KDB 662911 v02 for this testing.

1.8 General Test Condition

The conditions under which the EUT operates were varied to determine their effect on the equipment's emission characteristics. The final configuration of the test system and the mode of operation used during these tests were chosen as that which produced the highest emission levels. However, only those conditions which the EUT was considered likely to encounter in normal use were investigated. The system's radiated and conducted emissions were investigated while the computer alternately transferred data to the EUT as well as to the monitor and printer. Using a test program which sent a continuous data and transferred data to and from the EUT was proven to worst case emissions. The system's physical layout and cabling was randomly arranged to ensure that maximum emission levels were attained.

This assessment of the maximum conducted output power tests is based on the minimum transfer rate will produce a maximum output power.

802.11b data rate: 11M

802.11g data rate: 6M

802.11gn HT20 data rate: 13M

802.11gn HT40 data rate: 27M

Note: All conditions have been evaluated and the test result in this report is the worst case.

1.9 Duty cycle of Test Signal

Duty cycle of test signal is greater than or equal to 98%, duty cycle factor is not required.

802.11b

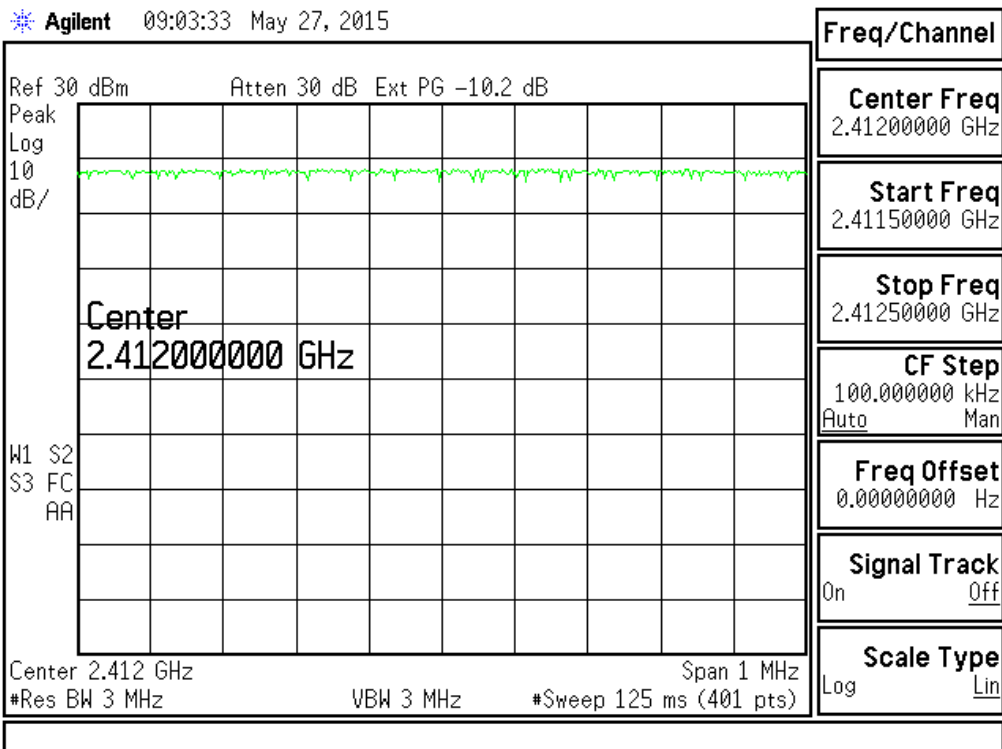

802.11g

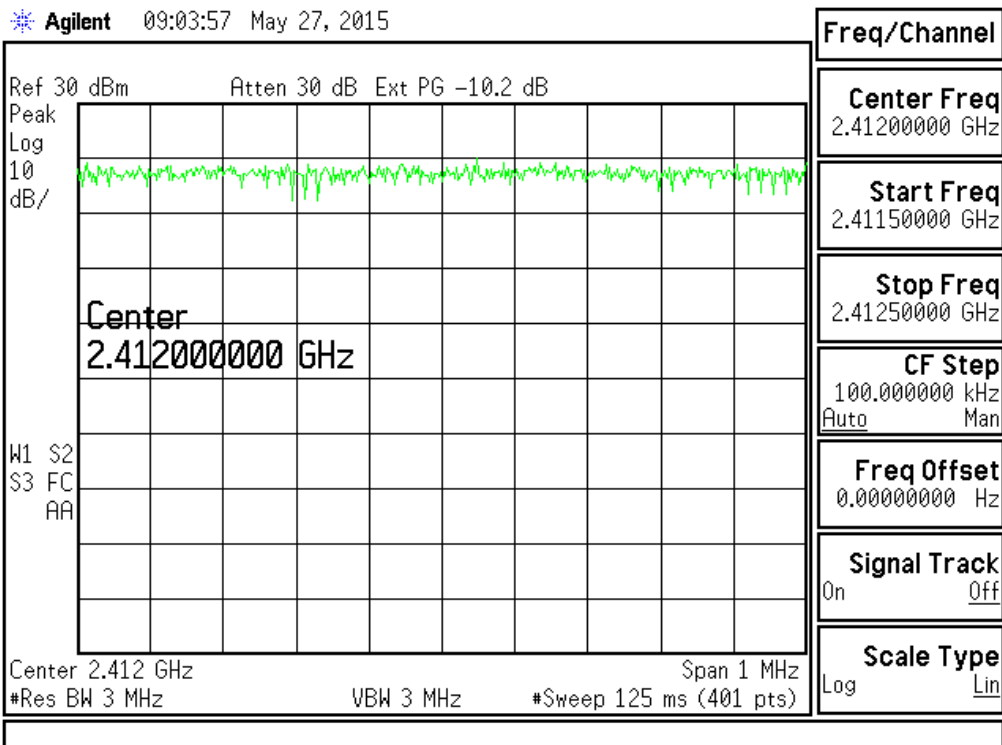

802.11n HT20

Agilent 09:04:27 May 27, 2015

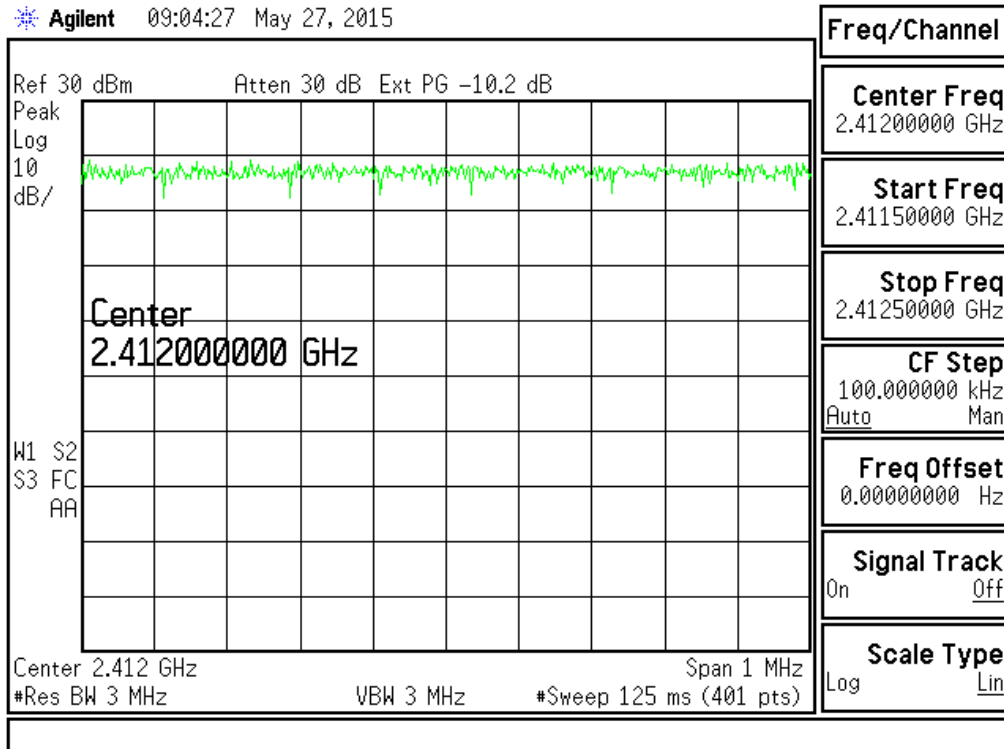

802.11gn HT40

Agilent 09:04:55 May 27, 2015

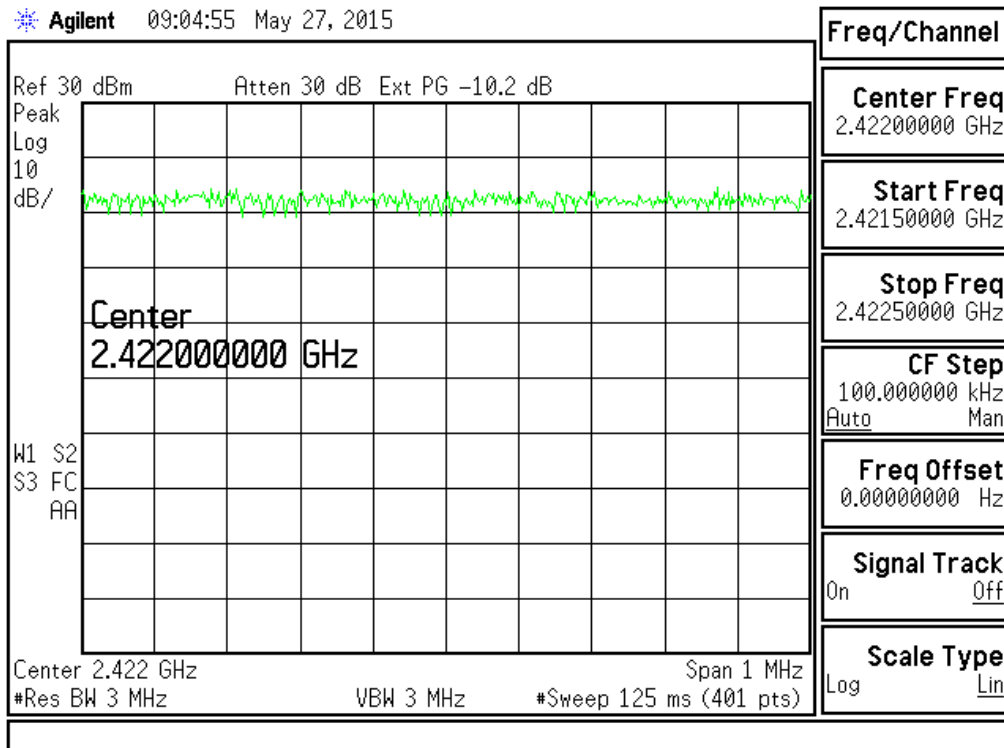

2. Conducted Emissions Requirements

2.1 General & Setup :

The power line conducted emission measurements were performed in a shielded enclosure. The EUT was assembled on a wooden table which is 80 centimeters high, was placed 40 centimeters from the back wall and at least 1 meter from the sidewall.

Power was fed to the EUT from the public utility power grid through a line filter and EMCO Model 3825/2 Line Impedance Stabilization Networks (LISN). The LISN housing, measuring instrumentation case, ground plane, etc., were electrically bonded together at the same RF potential. The Spectrum analyzer was connected to the AC line through an isolation transformer. The 50-ohm output of the LISN was connected to the spectrum analyzer directly. Conducted emission levels were in the CISPR quasi-peak detection mode. The analyzer's 6 dB bandwidth was set to 9 KHz. No post-detector video filter was used.

The spectrum was scanned from 150 KHz to 30 MHz. The physical arrangement of the test system and associated cabling was varied (within the scope of arrangements likely to be encountered in actual use) to determine the effect on the unit's emanations in amplitude and frequency. All spurious emission frequencies were observed. The highest emission amplitudes relative to the appropriate limit were measured and have been recorded in paragraph 2.5.

2.2 Test Equipment List :

Item	Mfr/Brand	Instruments	Serial No.	Model/Type No.	Calibrated Date	Next Cal. Date
1.	HP	Spectrum Analyzer	73412A00110	8591EM	2015/04/13	2016/04/13
2.	EMCO	LISN	2658	3825/2	2015/03/19	2016/03/19
3.	TESEQ	ISN	24801	ISN T8	2015/12/14	2016/12/14

2.3 Test Condition :

EUT tested in accordance with the specifications given by the manufacturer, and exercised in the most unfavorable manner.

2.4 Conducted Emissions Limits :

FCC Part 15

Frequency range (MHz)	Limits (dBuV)			
	Class A		Class B	
	QP	Avg.	QP	Avg.
0.15 to 0.50	79	66	66 to 56	56 to 46
0.50 to 5.0	73	60	56	46
5.0 to 30	73	60	60	50

2.5 Measurement Data Of Conducted Emissions :

2.5.1 Conducted Emissions

The following table shows a summary of the highest emissions of power line conducted emissions to the HOT and NEUTRAL conductor of the EUT power.

Test Mode : 802.11b (CH01)

Conducted Emissions								
Conductor	Frequency (MHz)	Read(dBuV)		Factor	Limits (dBuV)		Amplitude (dBuV)	
		QP	AV		QP	AV	QP	AV
L1	0.153	47.18	--	1.05	65.82	55.82	48.23	--
	0.206	42.26	--	1.12	63.36	53.36	43.38	--
	0.294	38.01	--	1.15	60.41	50.41	39.16	--
	0.348	34.76	--	1.15	59	49	35.91	--
	0.387	33.31	--	1.17	58.12	48.12	34.48	--
	12.318	33.23	--	1.99	60	50	35.22	--
	22.063	32.81	--	2.21	60	50	35.02	--
L2	0.153	48.17	--	0.93	65.82	55.82	49.10	--
	0.197	40.97	--	1.07	63.76	53.76	42.04	--
	0.255	37.79	--	1.09	61.6	51.6	38.88	--
	0.294	37.11	--	1.07	60.41	50.41	38.18	--
	0.958	32.05	--	1.21	56	46	33.26	--
	8.916	34.49	--	1.92	60	50	36.41	--
	12.318	35.44	--	1.98	60	50	37.42	--

- Notes :**
1. L1: One end & Ground L2: The other end & Ground
 2. Height of table on which the EUT was placed : 0.8 m.
 3. The Quasi-Peak Value have already met the Average Value Limit showed on above limits.
 4. The above test results are obtained under the normal condition.
 5. Amplitude = Read + Factor

2.5.2 Conducted Emissions

The following table shows a summary of the highest emissions of power line conducted emissions to the HOT and NEUTRAL conductor of the EUT power.

Test Mode : 802.11b (CH06)

Conducted Emissions								
Conductor	Frequency (MHz)	Read(dBuV)		Factor	Limits (dBuV)		Amplitude (dBuV)	
		QP	AV		QP	AV	QP	AV
L1	0.157	46.75	--	1.05	65.6	55.6	47.80	--
	0.202	41.91	--	1.12	63.54	53.54	43.03	--
	0.260	41.47	--	1.14	61.42	51.42	42.61	--
	0.285	41.31	--	1.15	60.68	50.68	42.46	--
	0.334	41.31	--	1.15	59.35	49.35	42.46	--
	7.893	33.59	--	2.04	60	50	35.63	--
	12.318	33.09	--	1.99	60	50	35.08	--
L2	0.153	47.05	--	0.93	65.82	55.82	47.98	--
	0.206	41.72	--	1.07	63.36	53.36	42.79	--
	0.285	43.84	--	1.07	60.68	50.68	44.91	--
	0.339	44.89	--	1.09	59.22	49.22	45.98	--
	0.417	39.04	--	1.12	57.51	47.51	40.16	--
	8.546	35.22	--	1.93	60	50	37.15	--
	12.060	35.70	--	1.97	60	50	37.67	--

- Notes :**
1. L1: One end & Ground L2: The other end & Ground
 2. Height of table on which the EUT was placed : 0.8 m.
 3. The Quasi-Peak Value have already met the Average Value Limit showed on above limits.
 4. The above test results are obtained under the normal condition.
 5. Amplitude = Read + Factor

2.5.3 Conducted Emissions

The following table shows a summary of the highest emissions of power line conducted emissions to the HOT and NEUTRAL conductor of the EUT power.

Test Mode : 802.11b (CH11)

Conducted Emissions								
Conductor	Frequency (MHz)	Read(dBuV)		Factor	Limits (dBuV)		Amplitude (dBuV)	
		QP	AV		QP	AV	QP	AV
L1	0.157	46.42	--	1.05	65.6	55.6	47.47	--
	0.206	40.46	--	1.12	63.36	53.36	41.58	--
	0.270	37.44	--	1.14	61.12	51.12	38.58	--
	0.313	36.97	--	1.15	59.88	49.88	38.12	--
	0.363	34.62	--	1.15	58.65	48.65	35.77	--
	0.421	33.61	--	1.17	57.42	47.42	34.78	--
	7.687	33.79	--	2.04	60	50	35.83	--
L2	0.157	46.37	--	0.93	65.6	55.6	47.30	--
	0.206	39.06	--	1.07	63.36	53.36	40.13	--
	0.260	35.76	--	1.09	61.42	51.42	36.85	--
	0.303	35.90	--	1.07	60.15	50.15	36.97	--
	1.352	31.74	--	1.32	56	46	33.06	--
	8.683	35.36	--	1.93	60	50	37.29	--
	12.384	36.18	--	1.98	60	50	38.16	--

- Notes :**
1. L1: One end & Ground L2: The other end & Ground
 2. Height of table on which the EUT was placed : 0.8 m.
 3. The Quasi-Peak Value have already met the Average Value Limit showed on above limits.
 4. The above test results are obtained under the normal condition.
 5. Amplitude = Read + Factor

2.5.4 Conducted Emissions

The following table shows a summary of the highest emissions of power line conducted emissions to the HOT and NEUTRAL conductor of the EUT power.

Test Mode : 802.11g (CH01)

Conducted Emissions								
Conductor	Frequency (MHz)	Read(dBuV)		Factor	Limits (dBuV)		Amplitude (dBuV)	
		QP	AV		QP	AV	QP	AV
L1	0.153	48.59	--	1.05	65.82	55.82	49.64	--
	0.206	41.96	--	1.12	63.36	53.36	43.08	--
	0.255	39.38	--	1.14	61.6	51.6	40.52	--
	0.303	35.45	--	1.15	60.15	50.15	36.60	--
	0.352	34.16	--	1.15	58.91	48.91	35.31	--
	0.417	33.51	--	1.17	57.51	47.51	34.68	--
	7.646	33.58	--	2.02	60	50	35.60	--
L2	0.153	47.87	--	0.93	65.82	55.82	48.80	--
	0.202	40.79	--	1.07	63.54	53.54	41.86	--
	0.260	37.25	--	1.09	61.42	51.42	38.34	--
	0.300	38.36	--	1.07	60.24	50.24	39.43	--
	1.619	30.85	--	1.39	56	46	32.24	--
	8.729	35.29	--	1.90	60	50	37.19	--
	12.384	34.79	--	1.98	60	50	36.77	--

- Notes :**
1. L1: One end & Ground L2: The other end & Ground
 2. Height of table on which the EUT was placed : 0.8 m.
 3. The Quasi-Peak Value have already met the Average Value Limit showed on above limits.
 4. The above test results are obtained under the normal condition.
 5. Amplitude = Read + Factor

2.5.5 Conducted Emissions

The following table shows a summary of the highest emissions of power line conducted emissions to the HOT and NEUTRAL conductor of the EUT power.

Test Mode : 802.11g (CH06)

Conducted Emissions								
Conductor	Frequency (MHz)	Read(dBuV)		Factor	Limits (dBuV)		Amplitude (dBuV)	
		QP	AV		QP	AV	QP	AV
L1	0.153	47.93	--	1.05	65.82	55.82	48.98	--
	0.206	41.66	--	1.12	63.36	53.36	42.78	--
	0.255	38.70	--	1.14	61.6	51.6	39.84	--
	0.300	37.01	--	1.15	60.24	50.24	38.16	--
	0.417	33.63	--	1.17	57.51	47.51	34.80	--
	7.486	33.87	--	2.01	60	50	35.88	--
	12.318	33.51	--	1.99	60	50	35.50	--
L2	0.152	48.68	--	0.93	65.87	55.87	49.61	--
	0.212	40.63	--	1.07	63.14	53.14	41.70	--
	0.255	39.00	--	1.09	61.6	51.6	40.09	--
	0.300	37.37	--	1.07	60.24	50.24	38.44	--
	1.223	32.21	--	1.28	56	46	33.49	--
	8.412	35.36	--	1.92	60	50	37.28	--
	12.582	36.11	--	2.01	60	50	38.12	--

- Notes :**
1. L1: One end & Ground L2: The other end & Ground
 2. Height of table on which the EUT was placed : 0.8 m.
 3. The Quasi-Peak Value have already met the Average Value Limit showed on above limits.
 4. The above test results are obtained under the normal condition.
 5. Amplitude = Read + Factor

2.5.6 Conducted Emissions

The following table shows a summary of the highest emissions of power line conducted emissions to the HOT and NEUTRAL conductor of the EUT power.

Test Mode : 802.11g (CH11)

Conducted Emissions								
Conductor	Frequency (MHz)	Read(dBuV)		Factor	Limits (dBuV)		Amplitude (dBuV)	
		QP	AV		QP	AV	QP	AV
L1	0.152	48.15	--	1.05	65.87	55.87	49.20	--
	0.202	41.66	--	1.12	63.54	53.54	42.78	--
	0.251	39.26	--	1.14	61.73	51.73	40.40	--
	0.310	38.04	--	1.15	59.97	49.97	39.19	--
	0.421	33.38	--	1.17	57.42	47.42	34.55	--
	1.242	31.22	--	1.36	56	46	32.58	--
	7.446	33.77	--	2.04	60	50	35.81	--
L2	0.153	47.59	--	0.93	65.82	55.82	48.52	--
	0.206	41.96	--	1.07	63.36	53.36	43.03	--
	0.251	37.96	--	1.09	61.73	51.73	39.05	--
	0.303	37.91	--	1.07	60.15	50.15	38.98	--
	0.348	35.74	--	1.09	59	49	36.83	--
	0.402	33.62	--	1.12	57.81	47.81	34.74	--
	12.784	33.59	--	1.99	60	50	35.58	--

Notes : 1. L1: One end & Ground L2: The other end & Ground

2. Height of table on which the EUT was placed : 0.8 m.

3. The Quasi-Peak Value have already met the Average Value Limit showed on above limits.

4. The above test results are obtained under the normal condition.

5. Amplitude = Read + Factor

2.5.7 Conducted Emissions

The following table shows a summary of the highest emissions of power line conducted emissions to the HOT and NEUTRAL conductor of the EUT power.

Test Mode : 802.11n HT20 (CH01)

Conducted Emissions								
Conductor	Frequency (MHz)	Read(dBuV)		Factor	Limits (dBuV)		Amplitude (dBuV)	
		QP	AV		QP	AV	QP	AV
L1	0.152	48.57	--	1.05	65.87	55.87	49.62	--
	0.206	42.19	--	1.12	63.36	53.36	43.31	--
	0.251	38.77	--	1.14	61.73	51.73	39.91	--
	0.334	35.57	--	1.15	59.35	49.35	36.72	--
	0.369	34.75	--	1.15	58.52	48.52	35.90	--
	0.701	31.20	--	1.23	56	46	32.43	--
	7.526	34.11	--	2.01	60	50	36.12	--
L2	0.163	47.57	--	0.93	65.3	55.3	48.50	--
	0.206	40.30	--	1.07	63.36	53.36	41.37	--
	0.251	39.39	--	1.09	61.73	51.73	40.48	--
	0.310	34.90	--	1.07	59.97	49.97	35.97	--
	0.958	31.34	--	1.21	56	46	32.55	--
	7.852	35.78	--	1.92	60	50	37.70	--
	12.060	34.56	--	1.97	60	50	36.53	--

Notes : 1. L1: One end & Ground L2: The other end & Ground

2. Height of table on which the EUT was placed : 0.8 m.

3. The Quasi-Peak Value have already met the Average Value Limit showed on above limits.

4. The above test results are obtained under the normal condition.

5. Amplitude = Read + Factor

2.5.8 Conducted Emissions

The following table shows a summary of the highest emissions of power line conducted emissions to the HOT and NEUTRAL conductor of the EUT power.

Test Mode : 802.11n HT20 (CH06)

Conducted Emissions								
Conductor	Frequency (MHz)	Read(dBuV)		Factor	Limits (dBuV)		Amplitude (dBuV)	
		QP	AV		QP	AV	QP	AV
L1	0.157	47.45	--	1.05	65.6	55.6	48.50	--
	0.206	42.50	--	1.12	63.36	53.36	43.62	--
	0.260	38.54	--	1.14	61.42	51.42	39.68	--
	0.320	35.99	--	1.15	59.71	49.71	37.14	--
	0.398	34.43	--	1.17	57.9	47.9	35.60	--
	3.025	30.82	--	1.92	56	46	32.74	--
	12.188	33.94	--	2.00	60	50	35.94	--
L2	0.153	48.69	--	0.93	65.82	55.82	49.62	--
	0.206	41.46	--	1.07	63.36	53.36	42.53	--
	0.260	37.49	--	1.09	61.42	51.42	38.58	--
	1.426	31.20	--	1.32	56	46	32.52	--
	1.918	31.45	--	1.49	56	46	32.94	--
	8.869	35.11	--	1.91	60	50	37.02	--
	12.516	34.65	--	1.98	60	50	36.63	--

- Notes :**
1. L1: One end & Ground L2: The other end & Ground
 2. Height of table on which the EUT was placed : 0.8 m.
 3. The Quasi-Peak Value have already met the Average Value Limit showed on above limits.
 4. The above test results are obtained under the normal condition.
 5. Amplitude = Read + Factor

2.5.9 Conducted Emissions

The following table shows a summary of the highest emissions of power line conducted emissions to the HOT and NEUTRAL conductor of the EUT power.

Test Mode : 802.11n HT20 (CH11)

Conducted Emissions								
Conductor	Frequency (MHz)	Read(dBuV)		Factor	Limits (dBuV)		Amplitude (dBuV)	
		QP	AV		QP	AV	QP	AV
L1	0.157	46.92	--	1.05	65.6	55.6	47.97	--
	0.202	42.38	--	1.12	63.54	53.54	43.50	--
	0.252	38.49	--	1.14	61.69	51.69	39.63	--
	0.313	37.03	--	1.15	59.88	49.88	38.18	--
	0.410	33.82	--	1.17	57.64	47.64	34.99	--
	0.486	31.72	--	1.22	56.23	46.23	32.94	--
	7.566	33.32	--	1.99	60	50	35.31	--
L2	0.152	48.12	--	0.93	65.87	55.87	49.05	--
	0.197	41.42	--	1.07	63.76	53.76	42.49	--
	0.246	35.30	--	1.09	61.91	51.91	36.39	--
	0.291	36.49	--	1.07	60.5	50.5	37.56	--
	2.077	30.61	--	1.73	56	46	32.34	--
	8.501	35.71	--	1.92	60	50	37.63	--
	13.057	35.44	--	2.04	60	50	37.48	--

- Notes :**
1. L1: One end & Ground L2: The other end & Ground
 2. Height of table on which the EUT was placed : 0.8 m.
 3. The Quasi-Peak Value have already met the Average Value Limit showed on above limits.
 4. The above test results are obtained under the normal condition.
 5. Amplitude = Read + Factor

2.5.10 Conducted Emissions

The following table shows a summary of the highest emissions of power line conducted emissions to the HOT and NEUTRAL conductor of the EUT power.

Test Mode : 802.11n HT40 (CH03)

Conducted Emissions								
Conductor	Frequency (MHz)	Read(dBuV)		Factor	Limits (dBuV)		Amplitude (dBuV)	
		QP	AV		QP	AV	QP	AV
L1	0.158	46.87	--	1.05	65.56	55.56	47.92	--
	0.206	41.64	--	1.12	63.36	53.36	42.76	--
	0.255	38.75	--	1.14	61.6	51.6	39.89	--
	0.323	36.51	--	1.15	59.62	49.62	37.66	--
	0.402	33.75	--	1.17	57.81	47.81	34.92	--
	7.606	33.58	--	2.01	60	50	35.59	--
	12.582	33.88	--	2.04	60	50	35.92	--
L2	0.158	46.88	--	0.93	65.56	55.56	47.81	--
	0.202	41.56	--	1.07	63.54	53.54	42.63	--
	0.270	40.37	--	1.09	61.12	51.12	41.46	--
	0.303	35.67	--	1.07	60.15	50.15	36.74	--
	2.099	31.52	--	1.73	56	46	33.25	--
	8.148	35.82	--	1.97	60	50	37.79	--
	12.784	34.97	--	1.99	60	50	36.96	--

Notes : 1. L1: One end & Ground L2: The other end & Ground

2. Height of table on which the EUT was placed : 0.8 m.

3. The Quasi-Peak Value have already met the Average Value Limit showed on above limits.

4. The above test results are obtained under the normal condition.

5. Amplitude = Read + Factor

2.5.11 Conducted Emissions

The following table shows a summary of the highest emissions of power line conducted emissions to the HOT and NEUTRAL conductor of the EUT power.

Test Mode : 802.11n HT40 (CH06)

Conducted Emissions								
Conductor	Frequency (MHz)	Read(dBuV)		Factor	Limits (dBuV)		Amplitude (dBuV)	
		QP	AV		QP	AV	QP	AV
L1	0.156	47.08	--	1.05	65.69	55.69	48.13	--
	0.206	41.78	--	1.12	63.36	53.36	42.90	--
	0.251	38.33	--	1.14	61.73	51.73	39.47	--
	0.303	36.08	--	1.15	60.15	50.15	37.23	--
	0.421	32.74	--	1.17	57.42	47.42	33.91	--
	1.858	31.43	--	1.51	56	46	32.94	--
	7.769	33.75	--	2.03	60	50	35.78	--
L2	0.157	47.40	--	0.93	65.6	55.6	48.33	--
	0.206	39.97	--	1.07	63.36	53.36	41.04	--
	0.260	39.20	--	1.09	61.42	51.42	40.29	--
	0.303	35.16	--	1.07	60.15	50.15	36.23	--
	0.953	31.55	--	1.21	56	46	32.76	--
	8.729	35.70	--	1.90	60	50	37.60	--
	12.449	35.45	--	1.98	60	50	37.43	--

- Notes :**
1. L1: One end & Ground L2: The other end & Ground
 2. Height of table on which the EUT was placed : 0.8 m.
 3. The Quasi-Peak Value have already met the Average Value Limit showed on above limits.
 4. The above test results are obtained under the normal condition.
 5. Amplitude = Read + Factor

2.5.12 Conducted Emissions

The following table shows a summary of the highest emissions of power line conducted emissions to the HOT and NEUTRAL conductor of the EUT power.

Test Mode : 802.11n HT40 (CH09)

Conducted Emissions								
Conductor	Frequency (MHz)	Read(dBuV)		Factor	Limits (dBuV)		Amplitude (dBuV)	
		QP	AV		QP	AV	QP	AV
L1	0.153	46.37	--	1.05	65.82	55.82	47.42	--
	0.212	41.57	--	1.12	63.14	53.14	42.69	--
	0.255	37.33	--	1.14	61.6	51.6	38.47	--
	0.313	36.69	--	1.15	59.88	49.88	37.84	--
	0.352	33.62	--	1.15	58.91	48.91	34.77	--
	0.486	31.68	--	1.22	56.23	46.23	32.90	--
	8.062	35.48	--	1.98	60	50	37.46	--
L2	0.157	47.15	--	0.93	65.6	55.6	48.08	--
	0.202	40.79	--	1.07	63.54	53.54	41.86	--
	0.264	38.64	--	1.09	61.29	51.29	39.73	--
	0.302	34.68	--	1.07	60.19	50.19	35.75	--
	0.369	32.55	--	1.09	58.52	48.52	33.64	--
	9.011	35.15	--	1.92	60	50	37.07	--
	12.384	36.03	--	1.98	60	50	38.01	--

Notes : 1. L1: One end & Ground L2: The other end & Ground

2. Height of table on which the EUT was placed : 0.8 m.

3. The Quasi-Peak Value have already met the Average Value Limit showed on above limits.

4. The above test results are obtained under the normal condition.

5. Amplitude = Read + Factor

3. Radiated Emissions Requirement

3.1 General Configuration:

Prior to open-field testing, the EUT was placed in a shielded enclosure and scanned at a close distance to determine its emission characteristics. The physical arrangement of the EUT was varied (within the scope of arrangements likely to be encountered in actual use) to determine the effect on the unit's emanations in amplitude, directivity, and frequency. The exact system configuration which produced the highest emissions was noted so it could be reproduced later during the open-field tests. This was done to ensure that the final measurements would demonstrate the worst-case interference potential of the EUT.

Final radiation measurements were made on a three-meter, open-field test site. The EUT system was placed on a nonconductive turntable which was 0.8 meters height (from 30 MHz to 1 GHz), turntable which was 1.5 meters height (from 1GHz to 26.5GHz), top surface 1.0 x 1.5 meter. During the test, EUT was set to transmit continuously & measurements spectrum range from 30 MHz to 26.5 GHz is investigated.

For measurements above 1 GHz the resolution bandwidth is set to 1 MHz, then the video bandwidth is set to 1 MHz for peak measurements and 10 Hz for average measurements.

A nonconductive material surrounded the EUT to supporting the EUT for standing on three orthogonal planes. At each condition, the EUT was rotated 360 degrees, and the antenna was raised and lowered from one to four meters to find the maximum emission levels. Measurements were taken using both horizontal and vertical antenna polarization.

For testing above 1GHz, the emission level of the EUT in peak mode was 20dB lower than average limit (that means the emission level in peak mode also complies with the limit in average mode), then testing will be stopped and peak values of EUT will be reported, otherwise, the emissions will be measured in average mode again and reported.

Appropriate preamplifiers were used for improving sensitivity and precautions were taken to avoid overloading or desensitizing the spectrum analyzer. No post – detector video filters were used in the test.

The spectrum analyzer's 6 dB bandwidth was set to 1 MHz, and the analyzer was operated in the peak detection mode, for frequencies both below and up 1 GHz. The average levels were obtained by subtracting the duty cycle correction factor from the peak readings.

The following procedures were used to convert the emission levels measured in decibels referenced to 1 microvolt (dBuV) into field intensity in microvolts pre meter (uV/m).

The actual field intensity in decibels referenced to 1 microvolt in to field intensity in microvolts per meter (dBuV/m).

The actual field intensity in referenced to 1 microvolt per meter (dBuV/m) is determined by algebraically adding the measured reading in dBuV, the antenna factor (dB), and cable loss (dB) and Subtracting the gain of preamplifier (dB) is auto calculate in spectrum analyzer.

$$\text{Amplitude (dBuV/m)} = \text{FI(dBuV)} + \text{AF(dBm)} + \text{CL(dBuV)} - \text{Gain(dB)}$$

FI= Reading of the field intensity.

AF= Antenna factor.

CL= Cable loss.

P.S Amplitude is auto calculate in spectrum analyzer.

The FCC specified emission limits were calculated according the EUT operating frequency and by following linear interpolation equations:

(1) For fundamental frequency : Transmitter Output < +30dBm

(2) For spurious frequency : Spurious emission limits = fundamental emission limit /10

3.2 Test Equipment List:

Item	Mfr/Brand	Instruments	Serial No.	Model/Type No.	Calibrated Date	Next Cal. Date
1.	Agilent	Spectrum Analyzer	US44300422	E4446A	2015/02/04	2016/02/04
2.	MLT	Pre Amplifier	20110301	PREAMP6G-02	2015/03/17	2016/03/17
3.	Agilent	Spectrum Analyzer	US40240137	E7403A	2015/03/16	2016/03/16
4.	MLT	Pre Amplifier	0.10~19.1GHz 60dBm	RF01	2015/11/17	2016/11/17
5.	MLT	Pre Amplifier	TA010-190-30	RF03	2015/08/10	2016/08/10
6.	MLT	Pre Amplifier	20110209	PREAMP6G-01	2015/03/17	2016/03/17
7.	Herotek	Pre Amplifier	30690	A402-417	2015/11/17	2016/11/17
8.	EMCO	Biconilog Antenna	59739	3142C	2015/10/06	2016/10/06
9.	EMCO	Biconilog Antenna	44568	3142C	2015/10/06	2016/10/06
10.	SCHWARZBECK	Horn Antenna	181	BBHA 9170	2015/11/24	2016/11/24
11.	SCHWARZBECK	Horn Antenna	304	BBHA 9120D	2015/11/24	2016/11/24

3.3 Test condition:

EUT tested in accordance with the specifications given by the manufacturer, and exercised in the most unfavorable manner.

3.4 Radiated Emissions Limits:

Frequency range (MHz)	Peak(dBuV/m)
30 to 88	40
88 to 216	43.5
216 to 960	46
Above 960	54

3.5 Measurement Data Of Radiated Emissions:

3.5.1 Open Field Radiated Emissions (Subpart C)

The highest peak values of radiated emissions from the EUT at various antenna heights, antenna polarization, EUT orientation, etc. are recorded on the following

Test Mode : 802.11b (CH01)

Radiated Emissions (HORIZONTAL)									
Frequency (MHz)	Read (dBuV/m)		Factor	Amplitude (dBuV/m)		Limits (dBuV/m)		Margin (dB)	
	PK	AV		PK	AV	PK	AV	PK	AV
4815.0	64.32	56.58	-28.11	36.21	28.47	74.00	54.00	-37.79	-25.53
8775.0	56.80	52.22	-16.43	40.37	35.79	74.00	54.00	-33.63	-18.21

Radiated Emissions (VERTICAL)									
Frequency (MHz)	Read (dBuV/m)		Factor	Amplitude (dBuV/m)		Limits (dBuV/m)		Margin (dB)	
	PK	AV		PK	AV	PK	AV	PK	AV
4815.0	71.74	65.52	-28.11	43.63	37.41	74.00	54.00	-30.37	-16.59
7215.0	61.85	57.11	-21.25	40.60	35.86	74.00	54.00	-33.40	-18.14

- Notes :**
1. Margin= Amplitude – Limits
 2. Distance of Measurement : 3 Meter
 3. Height of table for EUT placed: 1.5 Meter.
 4. ANT= Antenna height.
 5. Duty= Duty cycle correction factor.
 6. Amplitude= Reading Amplitude – Amplifier gain + Cable loss + Antenna factor (Auto calculate in spectrum analyzer)
 7. The other emission levels were very low against the limit.

3.5.2 Open Field Radiated Emissions (Subpart C)

The highest peak values of radiated emissions from the EUT at various antenna heights, antenna polarization, EUT orientation, etc. are recorded on the following

Test Mode : 802.11b (CH06)

Radiated Emissions (HORIZONTAL)									
Frequency (MHz)	Read (dBuV/m)		Factor	Amplitude (dBuV/m)		Limits (dBuV/m)		Margin (dB)	
	PK	AV		PK	AV	PK	AV	PK	AV
4875.0	64.24	57.52	-28.18	36.06	29.34	74.00	54.00	-37.94	-24.66
9390.0	55.14	48.64	-14.86	40.28	33.78	74.00	54.00	-33.72	-20.22

Radiated Emissions (VERTICAL)									
Frequency (MHz)	Read (dBuV/m)		Factor	Amplitude (dBuV/m)		Limits (dBuV/m)		Margin (dB)	
	PK	AV		PK	AV	PK	AV	PK	AV
4875.0	71.68	66.75	-28.18	43.50	38.57	74.00	54.00	-30.50	-15.43
7290.0	61.47	55.52	-21.14	40.33	34.38	74.00	54.00	-33.67	-19.62

- Notes :**
1. Margin= Amplitude – Limits
 2. Distance of Measurement : 3 Meter
 3. Height of table for EUT placed: 1.5 Meter.
 4. ANT= Antenna height.
 5. Duty= Duty cycle correction factor.
 6. Amplitude= Reading Amplitude – Amplifier gain + Cable loss + Antenna factor (Auto calculate in spectrum analyzer)
 7. The other emission levels were very low against the limit.

3.5.3 Open Field Radiated Emissions (Subpart C)

The highest peak values of radiated emissions from the EUT at various antenna heights, antenna polarization, EUT orientation, etc. are recorded on the following

Test Mode : 802.11b (CH11)

Radiated Emissions (HORIZONTAL)									
Frequency (MHz)	Read (dBuV/m)		Factor	Amplitude (dBuV/m)		Limits (dBuV/m)		Margin (dB)	
	PK	AV		PK	AV	PK	AV	PK	AV
4920.0	64.88	57.63	-28.04	36.84	29.59	74.00	54.00	-37.16	-24.41
8790.0	56.70	51.10	-16.24	40.46	34.86	74.00	54.00	-33.54	-19.14

Radiated Emissions (VERTICAL)									
Frequency (MHz)	Read (dBuV/m)		Factor	Amplitude (dBuV/m)		Limits (dBuV/m)		Margin (dB)	
	PK	AV		PK	AV	PK	AV	PK	AV
4920.0	67.55	63.21	-28.04	39.51	35.17	74.00	54.00	-34.49	-18.83
7365.0	60.37	55.74	-21.24	39.13	34.50	74.00	54.00	-34.87	-19.50

Notes : 1. Margin= Amplitude – Limits

2. Distance of Measurement : 3 Meter

3. Height of table for EUT placed: 1.5 Meter.

4. ANT= Antenna height.

5. Duty= Duty cycle correction factor.

6. Amplitude= Reading Amplitude – Amplifier gain + Cable loss + Antenna factor
(Auto calculate in spectrum analyzer)

7. The other emission levels were very low against the limit.

3.5.4 Open Field Radiated Emissions (Subpart C)

The highest peak values of radiated emissions from the EUT at various antenna heights, antenna polarization, EUT orientation, etc. are recorded on the following

Test Mode : 802.11g (CH01)

Radiated Emissions (HORIZONTAL)									
Frequency (MHz)	Read (dBuV/m)		Factor	Amplitude (dBuV/m)		Limits (dBuV/m)		Margin (dB)	
	PK	AV		PK	AV	PK	AV	PK	AV
4815.0	62.90	56.52	-28.11	34.79	28.41	74.00	54.00	-39.21	-25.59
7140.0	58.31	52.54	-21.49	36.82	31.05	74.00	54.00	-37.18	-22.95

Radiated Emissions (VERTICAL)									
Frequency (MHz)	Read (dBuV/m)		Factor	Amplitude (dBuV/m)		Limits (dBuV/m)		Margin (dB)	
	PK	AV		PK	AV	PK	AV	PK	AV
4815.0	66.68	59.52	-28.11	38.57	31.41	74.00	54.00	-35.43	-22.59
7245.0	63.40	55.64	-21.50	41.90	34.14	74.00	54.00	-32.10	-19.86

Notes : 1. Margin= Amplitude – Limits

2. Distance of Measurement : 3 Meter

3. Height of table for EUT placed: 1.5 Meter.

4. ANT= Antenna height.

5. Duty= Duty cycle correction factor.

6. Amplitude= Reading Amplitude – Amplifier gain + Cable loss + Antenna factor
(Auto calculate in spectrum analyzer)

7. The other emission levels were very low against the limit.

3.5.5 Open Field Radiated Emissions (Subpart C)

The highest peak values of radiated emissions from the EUT at various antenna heights, antenna polarization, EUT orientation, etc. are recorded on the following

Test Mode : 802.11g (CH06)

Radiated Emissions (HORIZONTAL)									
Frequency (MHz)	Read (dBuV/m)		Factor	Amplitude (dBuV/m)		Limits (dBuV/m)		Margin (dB)	
	PK	AV		PK	AV	PK	AV	PK	AV
2000.0	36.84	33.85	-2.32	34.52	31.53	74.00	54.00	-39.48	-22.47
7215.0	58.23	52.51	-21.25	36.98	31.26	74.00	54.00	-37.02	-22.74

Radiated Emissions (VERTICAL)									
Frequency (MHz)	Read (dBuV/m)		Factor	Amplitude (dBuV/m)		Limits (dBuV/m)		Margin (dB)	
	PK	AV		PK	AV	PK	AV	PK	AV
4875.0	68.11	61.41	-28.18	39.93	33.23	74.00	54.00	-34.07	-20.77
7290.0	62.70	56.54	-21.14	41.56	35.40	74.00	54.00	-32.44	-18.60

Notes : 1. Margin= Amplitude – Limits

2. Distance of Measurement : 3 Meter

3. Height of table for EUT placed: 1.5 Meter.

4. ANT= Antenna height.

5. Duty= Duty cycle correction factor.

6. Amplitude= Reading Amplitude – Amplifier gain + Cable loss + Antenna factor
(Auto calculate in spectrum analyzer)

7. The other emission levels were very low against the limit.

3.5.6 Open Field Radiated Emissions (Subpart C)

The highest peak values of radiated emissions from the EUT at various antenna heights, antenna polarization, EUT orientation, etc. are recorded on the following

Test Mode : 802.11g (CH11)

Radiated Emissions (HORIZONTAL)									
Frequency (MHz)	Read (dBuV/m)		Factor	Amplitude (dBuV/m)		Limits (dBuV/m)		Margin (dB)	
	PK	AV		PK	AV	PK	AV	PK	AV
4920.0	63.57	60.22	-28.04	35.53	32.18	74.00	54.00	-38.47	-21.82
7995.0	57.78	52.33	-18.60	39.18	33.73	74.00	54.00	-34.82	-20.27

Radiated Emissions (VERTICAL)									
Frequency (MHz)	Read (dBuV/m)		Factor	Amplitude (dBuV/m)		Limits (dBuV/m)		Margin (dB)	
	PK	AV		PK	AV	PK	AV	PK	AV
4920.0	67.12	67.06	-28.04	39.08	39.02	74.00	54.00	-34.92	-14.98
7365.0	61.87	57.52	-21.24	40.63	36.28	74.00	54.00	-33.37	-17.72

- Notes :**
1. Margin= Amplitude – Limits
 2. Distance of Measurement : 3 Meter
 3. Height of table for EUT placed: 1.5 Meter.
 4. ANT= Antenna height.
 5. Duty= Duty cycle correction factor.
 6. Amplitude= Reading Amplitude – Amplifier gain + Cable loss + Antenna factor (Auto calculate in spectrum analyzer)
 7. The other emission levels were very low against the limit.

3.5.7 Open Field Radiated Emissions (Subpart C)

The highest peak values of radiated emissions from the EUT at various antenna heights, antenna polarization, EUT orientation, etc. are recorded on the following

Test Mode : 802.11n HT20 (CH01)

Radiated Emissions (HORIZONTAL)									
Frequency (MHz)	Read (dBuV/m)		Factor	Amplitude (dBuV/m)		Limits (dBuV/m)		Margin (dB)	
	PK	AV		PK	AV	PK	AV	PK	AV
2000.0	37.43	34.12	-2.32	35.11	31.80	74.00	54.00	-38.89	-22.20
7215.0	57.60	50.21	-21.25	36.35	28.96	74.00	54.00	-37.65	-25.04

Radiated Emissions (VERTICAL)									
Frequency (MHz)	Read (dBuV/m)		Factor	Amplitude (dBuV/m)		Limits (dBuV/m)		Margin (dB)	
	PK	AV		PK	AV	PK	AV	PK	AV
2040.0	42.20	37.52	-1.72	40.48	35.80	74.00	54.00	-33.52	-18.20
7215.0	63.99	60.65	-21.25	42.74	39.40	74.00	54.00	-31.26	-14.60

Notes : 1. Margin= Amplitude – Limits

2. Distance of Measurement : 3 Meter

3. Height of table for EUT placed: 1.5 Meter.

4. ANT= Antenna height.

5. Duty= Duty cycle correction factor.

6. Amplitude= Reading Amplitude – Amplifier gain + Cable loss + Antenna factor
(Auto calculate in spectrum analyzer)

7. The other emission levels were very low against the limit.

3.5.8 Open Field Radiated Emissions (Subpart C)

The highest peak values of radiated emissions from the EUT at various antenna heights, antenna polarization, EUT orientation, etc. are recorded on the following

Test Mode : 802.11n HT20 (CH06)

Radiated Emissions (HORIZONTAL)									
Frequency (MHz)	Read (dBuV/m)		Factor	Amplitude (dBuV/m)		Limits (dBuV/m)		Margin (dB)	
	PK	AV		PK	AV	PK	AV	PK	AV
1992.0	45.46	38.23	-2.35	43.11	35.88	74.00	54.00	-30.89	-18.12
19735.0	37.17	30.00	17.93	55.10	47.93	74.00	54.00	-18.90	-6.07

Radiated Emissions (VERTICAL)									
Frequency (MHz)	Read (dBuV/m)		Factor	Amplitude (dBuV/m)		Limits (dBuV/m)		Margin (dB)	
	PK	AV		PK	AV	PK	AV	PK	AV
1992.0	43.50	36.41	-2.35	41.15	34.06	74.00	54.00	-32.85	-19.94
7290.0	62.13	57.41	-21.14	40.99	36.27	74.00	54.00	-33.01	-17.73

Notes : 1. Margin= Amplitude – Limits

2. Distance of Measurement : 3 Meter

3. Height of table for EUT placed: 1.5 Meter.

4. ANT= Antenna height.

5. Duty= Duty cycle correction factor.

6. Amplitude= Reading Amplitude – Amplifier gain + Cable loss + Antenna factor
(Auto calculate in spectrum analyzer)

7. The other emission levels were very low against the limit.

3.5.9 Open Field Radiated Emissions (Subpart C)

The highest peak values of radiated emissions from the EUT at various antenna heights, antenna polarization, EUT orientation, etc. are recorded on the following

Test Mode : 802.11n HT20 (CH11)

Radiated Emissions (HORIZONTAL)									
Frequency (MHz)	Read (dBuV/m)		Factor	Amplitude (dBuV/m)		Limits (dBuV/m)		Margin (dB)	
	PK	AV		PK	AV	PK	AV	PK	AV
4920.0	62.81	51.23	-28.04	34.77	23.19	74.00	54.00	-39.23	-30.81
7140.0	57.81	51.42	-21.49	36.32	29.93	74.00	54.00	-37.68	-24.07

Radiated Emissions (VERTICAL)									
Frequency (MHz)	Read (dBuV/m)		Factor	Amplitude (dBuV/m)		Limits (dBuV/m)		Margin (dB)	
	PK	AV		PK	AV	PK	AV	PK	AV
2000.0	42.71	38.65	-2.32	40.39	36.33	74.00	54.00	-33.61	-17.67
7365.0	64.17	54.32	-21.24	42.93	33.08	74.00	54.00	-31.07	-20.92

Notes : 1. Margin= Amplitude – Limits

2. Distance of Measurement : 3 Meter

3. Height of table for EUT placed: 1.5 Meter.

4. ANT= Antenna height.

5. Duty= Duty cycle correction factor.

6. Amplitude= Reading Amplitude – Amplifier gain + Cable loss + Antenna factor
(Auto calculate in spectrum analyzer)

7. The other emission levels were very low against the limit.

3.5.10 Open Field Radiated Emissions (Subpart C)

The highest peak values of radiated emissions from the EUT at various antenna heights, antenna polarization, EUT orientation, etc. are recorded on the following

Test Mode : 802.11n HT40 (CH03)

Radiated Emissions (HORIZONTAL)									
Frequency (MHz)	Read (dBuV/m)		Factor	Amplitude (dBuV/m)		Limits (dBuV/m)		Margin (dB)	
	PK	AV		PK	AV	PK	AV	PK	AV
4845.0	63.43	56.85	-28.17	35.26	28.68	74.00	54.00	-38.74	-25.32
7245.0	57.36	53.20	-21.50	35.86	31.70	74.00	54.00	-38.14	-22.30

Radiated Emissions (VERTICAL)									
Frequency (MHz)	Read (dBuV/m)		Factor	Amplitude (dBuV/m)		Limits (dBuV/m)		Margin (dB)	
	PK	AV		PK	AV	PK	AV	PK	AV
2040.0	41.67	36.55	-1.72	39.95	34.83	74.00	54.00	-34.05	-19.17
7245.0	62.72	58.95	-21.50	41.22	37.45	74.00	54.00	-32.78	-16.55

Notes : 1. Margin= Amplitude – Limits

2. Distance of Measurement : 3 Meter

3. Height of table for EUT placed: 1.5 Meter.

4. ANT= Antenna height.

5. Duty= Duty cycle correction factor.

6. Amplitude= Reading Amplitude – Amplifier gain + Cable loss + Antenna factor
(Auto calculate in spectrum analyzer)

7. The other emission levels were very low against the limit.

3.5.11 Open Field Radiated Emissions (Subpart C)

The highest peak values of radiated emissions from the EUT at various antenna heights, antenna polarization, EUT orientation, etc. are recorded on the following

Test Mode : 802.11n HT40 (CH06)

Radiated Emissions (HORIZONTAL)									
Frequency (MHz)	Read (dBuV/m)		Factor	Amplitude (dBuV/m)		Limits (dBuV/m)		Margin (dB)	
	PK	AV		PK	AV	PK	AV	PK	AV
2000.0	36.87	33.85	-2.32	34.55	31.53	74.00	54.00	-39.45	-22.47
7470.0	56.25	52.84	-20.85	35.40	31.99	74.00	54.00	-38.60	-22.01

Radiated Emissions (VERTICAL)									
Frequency (MHz)	Read (dBuV/m)		Factor	Amplitude (dBuV/m)		Limits (dBuV/m)		Margin (dB)	
	PK	AV		PK	AV	PK	AV	PK	AV
2000.0	42.66	38.34	-2.32	40.34	36.02	74.00	54.00	-33.66	-17.98
7320.0	62.66	57.53	-21.48	41.18	36.05	74.00	54.00	-32.82	-17.95

- Notes :**
1. Margin= Amplitude – Limits
 2. Distance of Measurement : 3 Meter
 3. Height of table for EUT placed: 1.5 Meter.
 4. ANT= Antenna height.
 5. Duty= Duty cycle correction factor.
 6. Amplitude= Reading Amplitude – Amplifier gain + Cable loss + Antenna factor (Auto calculate in spectrum analyzer)
 7. The other emission levels were very low against the limit.

3.5.12 Open Field Radiated Emissions (Subpart C)

The highest peak values of radiated emissions from the EUT at various antenna heights, antenna polarization, EUT orientation, etc. are recorded on the following

Test Mode : 802.11n HT40 (CH09)

Radiated Emissions (HORIZONTAL)									
Frequency (MHz)	Read (dBuV/m)		Factor	Amplitude (dBuV/m)		Limits (dBuV/m)		Margin (dB)	
	PK	AV		PK	AV	PK	AV	PK	AV
2000.0	37.52	34.52	-2.32	35.20	32.20	74.00	54.00	-38.80	-21.80
7350.0	56.12	53.53	-21.22	34.90	32.31	74.00	54.00	-39.10	-21.69

Radiated Emissions (VERTICAL)									
Frequency (MHz)	Read (dBuV/m)		Factor	Amplitude (dBuV/m)		Limits (dBuV/m)		Margin (dB)	
	PK	AV		PK	AV	PK	AV	PK	AV
2000.0	41.51	38.04	-2.32	39.19	35.72	74.00	54.00	-34.81	-18.28
7350.0	63.91	57.40	-21.22	42.69	36.18	74.00	54.00	-31.31	-17.82

Notes : 1. Margin= Amplitude – Limits

2. Distance of Measurement : 3 Meter

3. Height of table for EUT placed: 1.5 Meter.

4. ANT= Antenna height.

5. Duty= Duty cycle correction factor.

6. Amplitude= Reading Amplitude – Amplifier gain + Cable loss + Antenna factor
(Auto calculate in spectrum analyzer)

7. The other emission levels were very low against the limit.

4. Maximum Conducted Output Power Requirements

4.1 Test Condition & Setup :

The tests below are run with the EUT's transmitter set at high power in TDD mode. A RJ-45 port from a computer to the EUT is needed to force selection of output power level and channel number. While testing, EUT was set to transmit continuously. Remove the Subjective device's antenna and connect the RF output port to spectrum analyzer. The maximum peak output power shall not exceed 1 watt.

The antenna port of the EUT was connected to the input of a power meter. Power was read directly and cable loss correction was added to the reading to obtain power at the EUT antenna terminals.

For antennas with gains of 6 dBi or less, maximum allowed transmitter output is 1 watt (+30 dBm). For antennas with gains greater than 6 dBi, transmitter output level must be decreased by an amount equal to $(\text{GAIN} - 6)/3$ dBm.

Measurement procedure is followed KDB 558074 v03r04 (9.1.1 : RBW \geq DTS bandwidth)

KDB 662911 D01 Multiple Transmitter Output v02 Method of conducted output power for

E) Guidance for summing emission measurements from multiple outputs of a transmitter or from multiple transmitters.

4.2 Test Instruments Configuration:

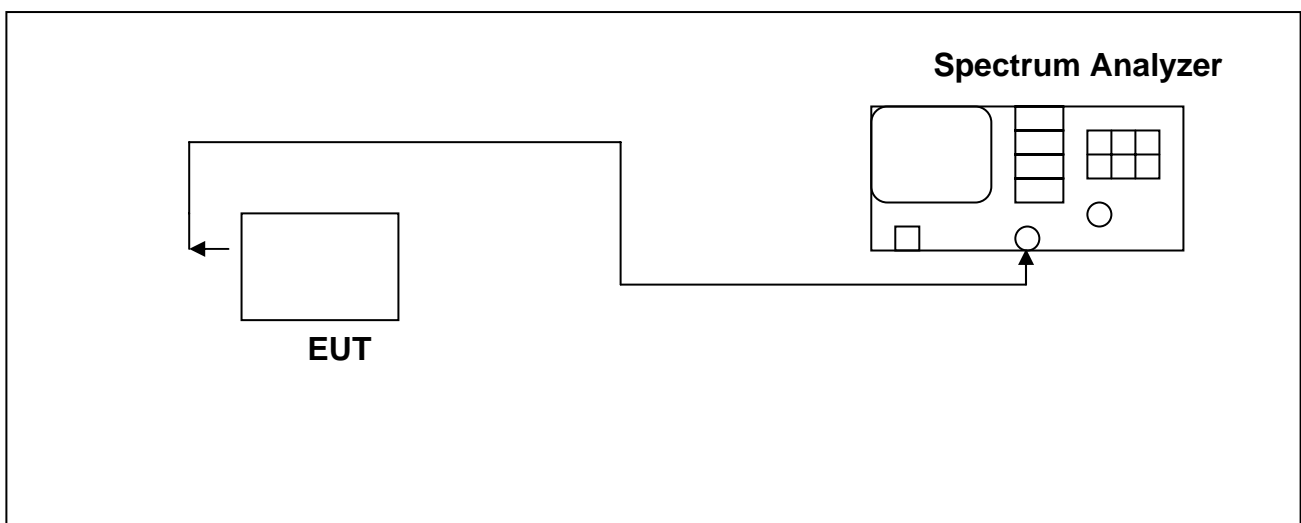

4.3 Test Equipment List:

Item	Mfr/Brand	Instruments	Serial No.	Model/Type No.	Calibrated Date	Next Cal. Date
1.	Agilent	Spectrum Analyzer	US44300422	E4446A	2015/02/04	2016/02/04

4.4 Test Result:

802.11b

Frequency (MHz)	Data Rate(Mbps)	Output(dBm)	Required Limit
2412	11	21.89	<30dBm
2412	5.5	20.64	<30dBm
2412	2	19.47	<30dBm
2412	1	19.45	<30dBm

Frequency (MHz)	Data Rate(Mbps)	Output(dBm)	Required Limit
2412	11	21.89	<30dBm
2437	11	21.90	<30dBm
2462	11	21.23	<30dBm

Note: The data rate listed on the table of each channel is the worst case (maximum output power)

802.11g

Frequency (MHz)	Data Rate(Mbps)	Output(dBm)	Required Limit
2412	54	20.93	<30dBm
2412	48	20.99	<30dBm
2412	36	20.97	<30dBm
2412	24	20.87	<30dBm
2412	18	20.59	<30dBm
2412	12	20.68	<30dBm
2412	9	20.39	<30dBm
2412	6	21.13	<30dBm

Frequency (MHz)	Data Rate(Mbps)	Output(dBm)	Required Limit
2412	6	21.13	<30dBm
2437	36	20.80	<30dBm
2462	6	20.83	<30dBm

Note: The data rate listed on the table of each channel is the worst case (maximum output power)

802.11n HT20

Frequency (MHz)	Data Rate(Mbps)		Output Power(dBm)		Required Limit
	Ant 1	Ant 2	Ant 1	Ant 2	
2412	130	130	20.10	19.60	<30dBm
2412	117	117	20.18	19.60	<30dBm
2412	104	104	20.22	19.46	<30dBm
2412	78	78	20.19	19.55	<30dBm
2412	52	52	20.57	19.90	<30dBm
2412	39	39	19.92	19.63	<30dBm
2412	26	26	19.91	19.60	<30dBm
2412	13	13	20.23	20.35	<30dBm

Frequency (MHz)	Data Rate(Mbps)		Output Power(dBm)		Total Output Power(dBm)	Required Limit
	Ant 1	Ant 2	Ant 1	Ant 2		
2412	52	13	20.57	20.35	23.47	<30dBm
2437	78	13	20.12	20.23	23.19	<30dBm
2462	13	13	20.16	19.83	23.01	<30dBm

Note: The data rate listed on the table of each channel is the worst case (maximum output power)

802.11n HT40

Frequency (MHz)	Data Rate(Mbps)		Output Power(dBm)		Required Limit
	Ant 1	Ant 2	Ant 1	Ant 2	
2422	270	270	19.57	19.82	<30dBm
2422	243	243	19.66	19.87	<30dBm
2422	216	216	19.46	19.80	<30dBm
2422	162	162	19.70	20.15	<30dBm
2422	108	108	19.87	20.34	<30dBm
2422	81	81	19.60	19.79	<30dBm
2422	54	54	19.57	19.94	<30dBm
2422	27	27	20.02	20.43	<30dBm

Frequency (MHz)	Data Rate(Mbps)		Output Power(dBm)		Total Output Power(dBm)	Required Limit
	Ant 1	Ant 2	Ant 1	Ant 2		
2422	27	27	20.02	20.43	23.24	<30dBm
2437	27	27	20.04	20.49	23.28	<30dBm
2452	27	27	19.83	20.37	23.12	<30dBm

Note: The data rate listed on the table of each channel is the worst case (maximum output power)

802.11b (2412MHz)

Agilent 15:59:29 May 25, 2015

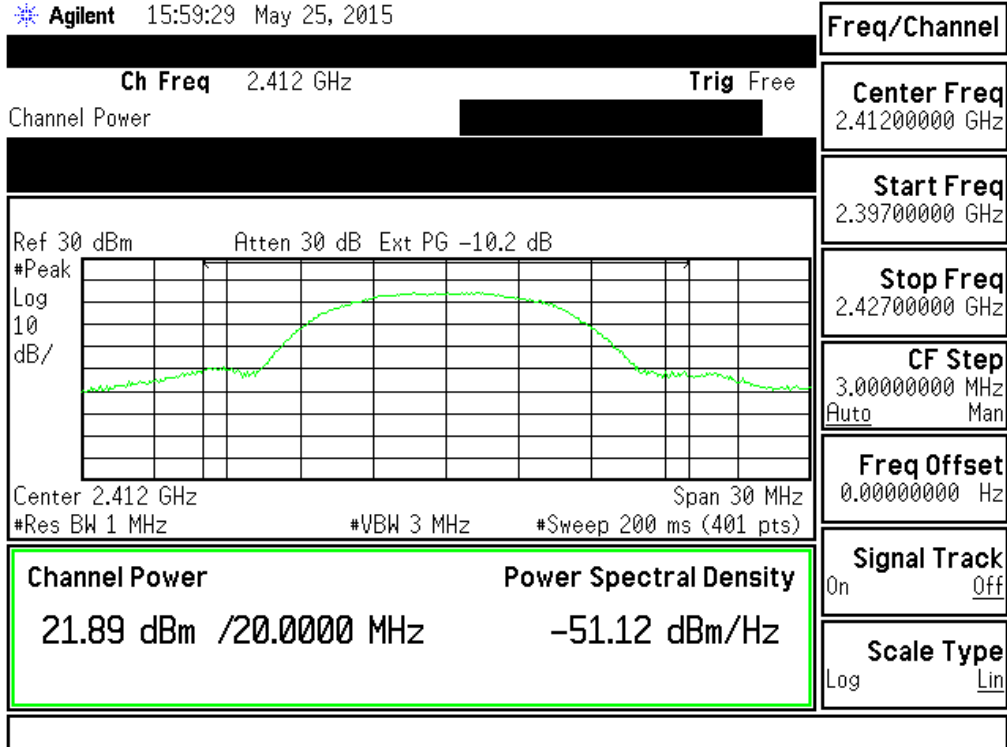

Note: Ext PG = Attenuator + Cable loss.

802.11b (2437MHz)

Agilent 16:04:22 May 25, 2015

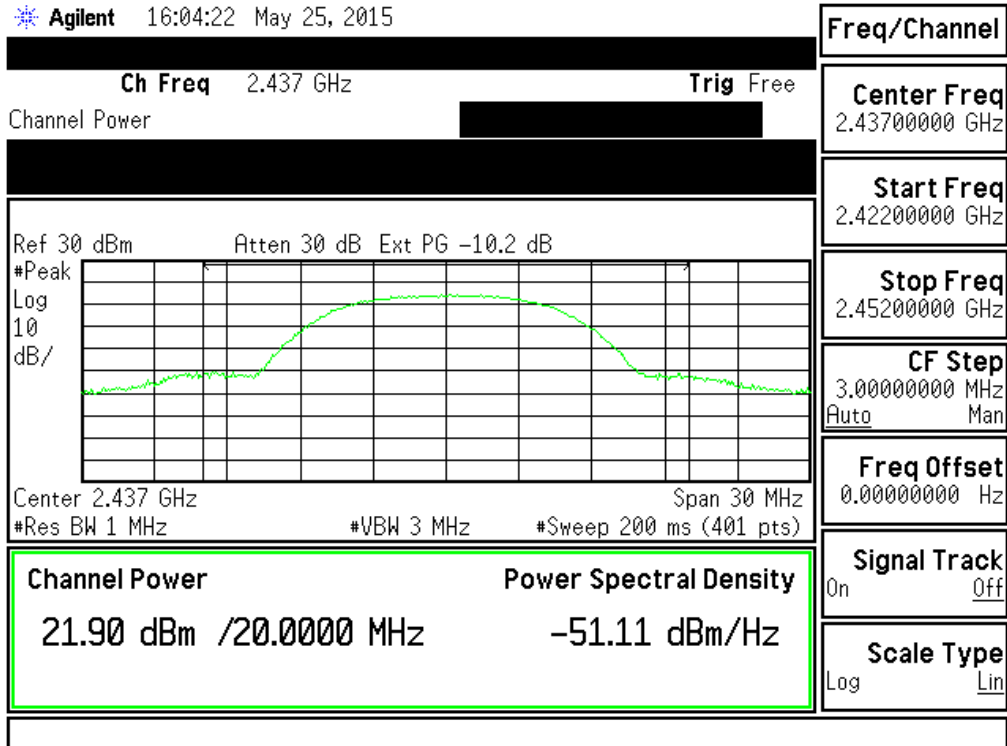

802.11b (2462MHz)

Agilent 16:06:04 May 25, 2015

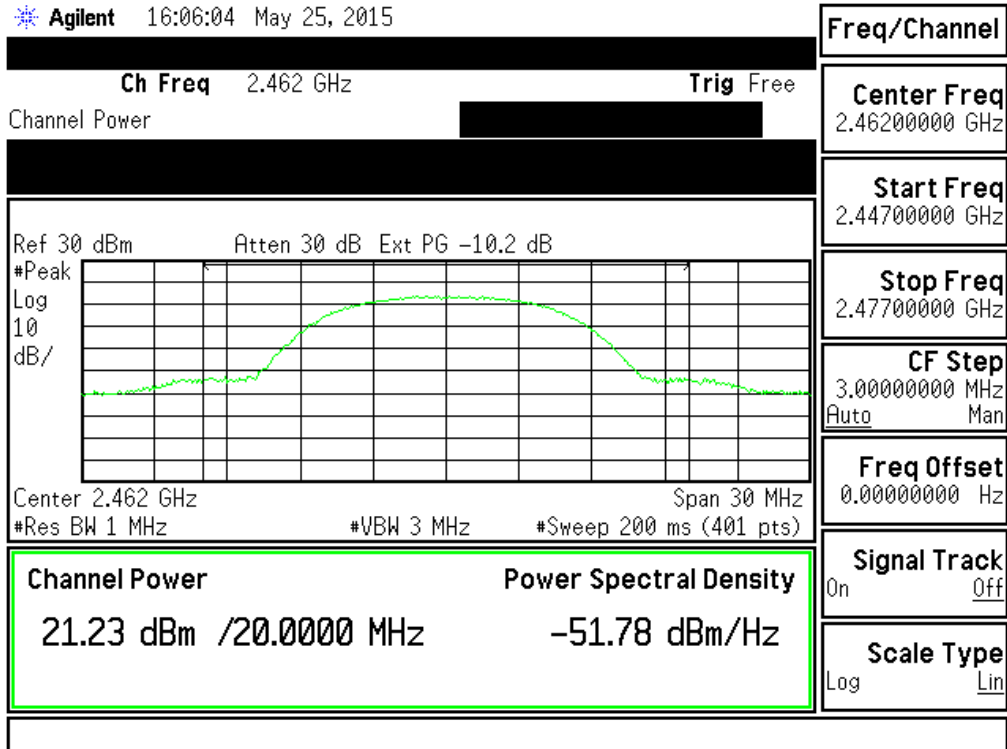

802.11g (2412MHz)

Agilent 08:47:06 Jun 22, 2015

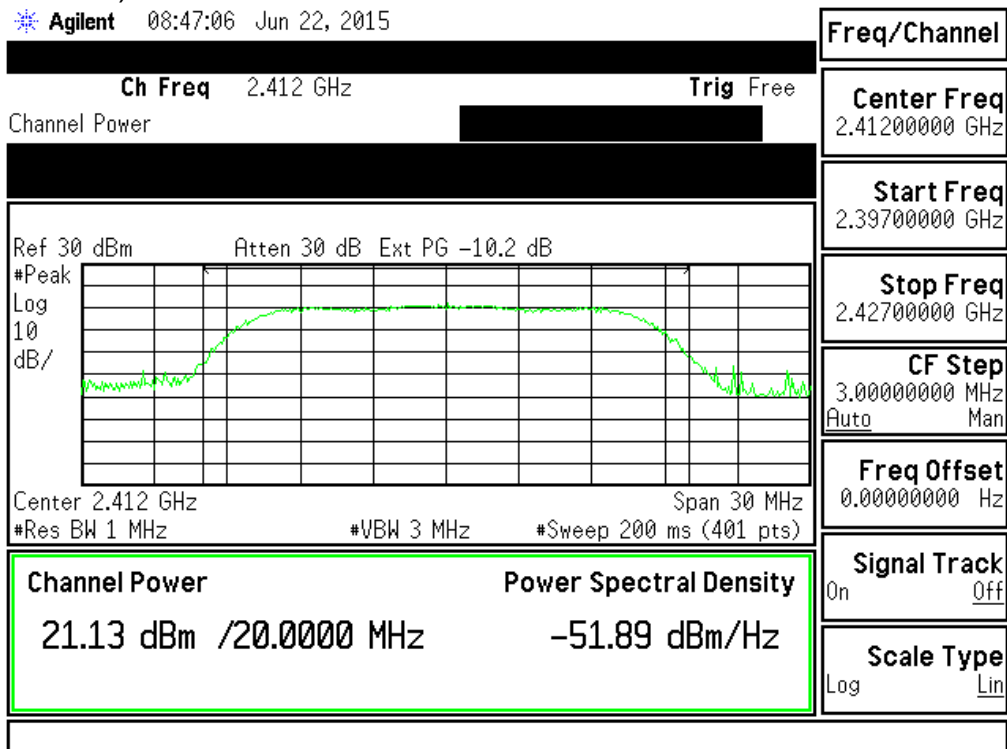

802.11g (2437MHz)

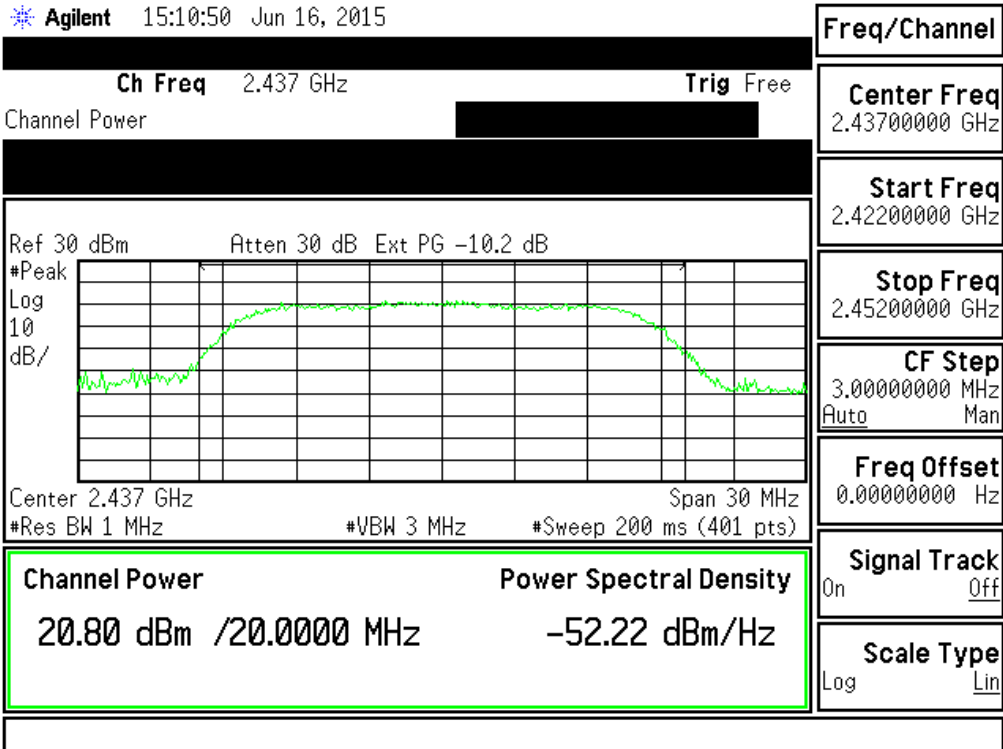

802.11g (2462MHz)

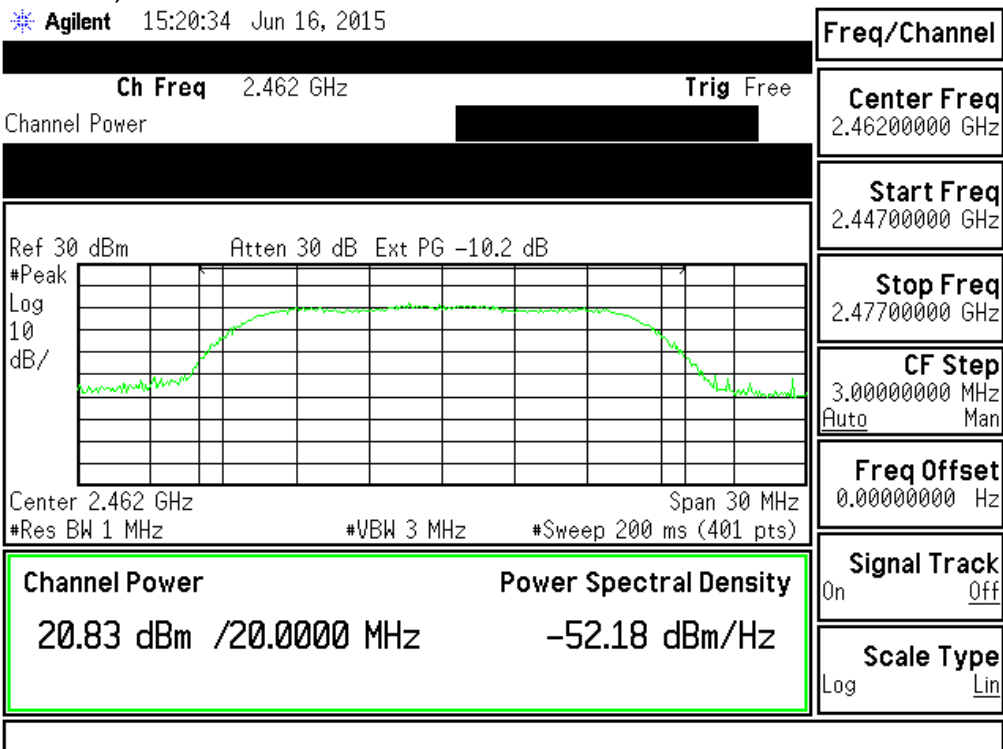

802.11HT20 ANT1 (2412MHz)

Agilent 15:27:09 Jun 16, 2015

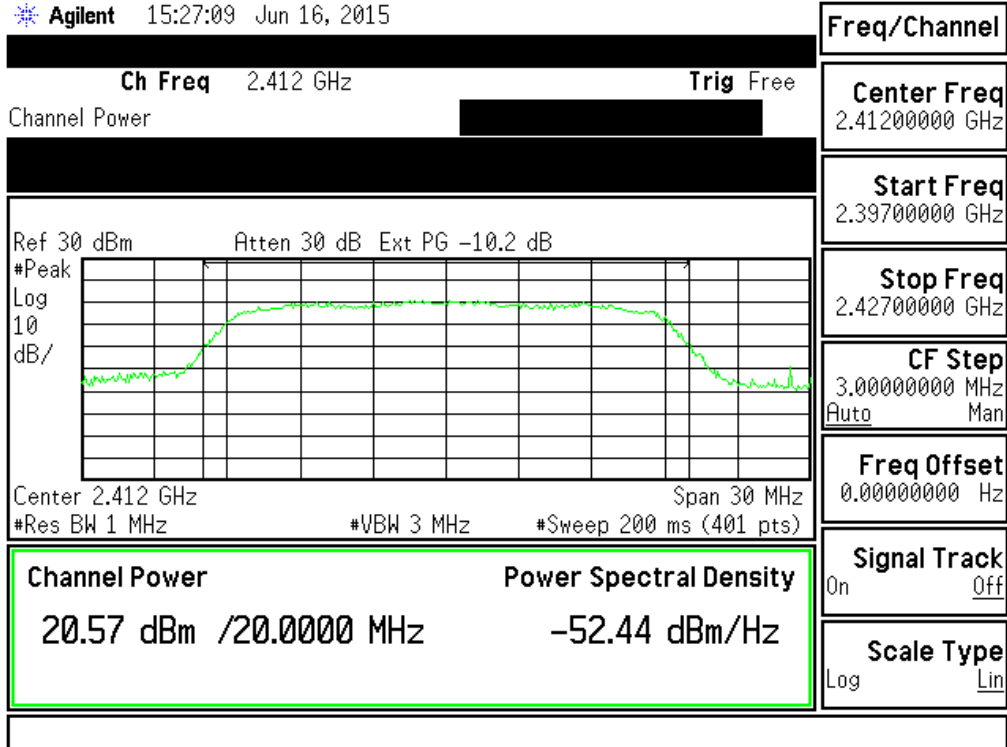

802.11HT20 ANT1 (2437MHz)

Agilent 15:42:50 Jun 16, 2015

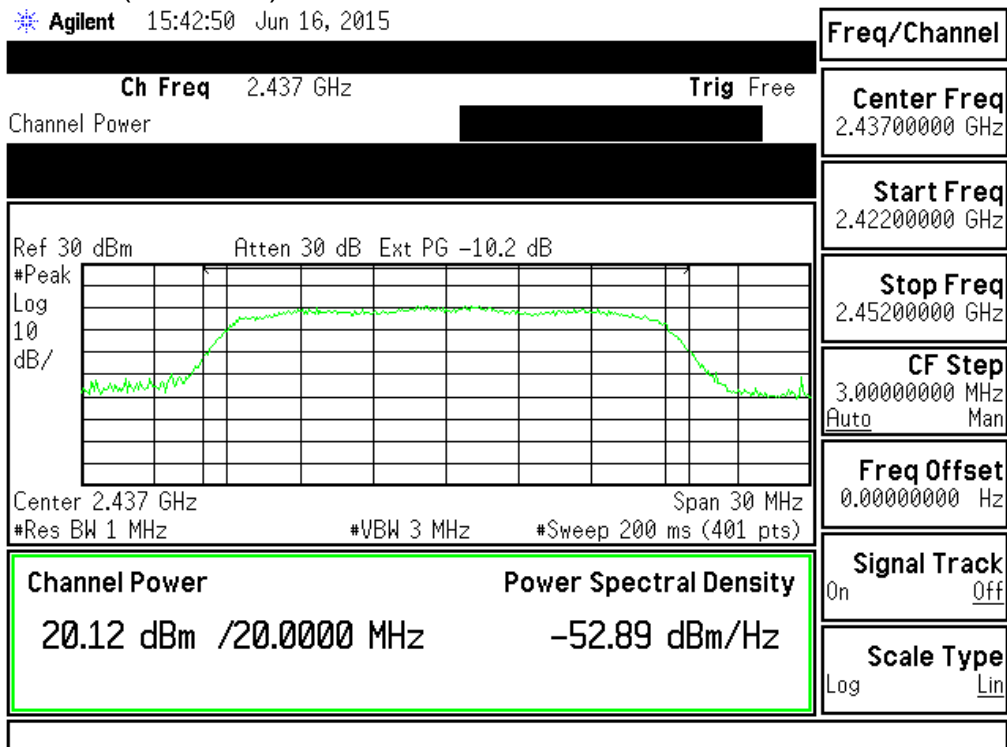

802.11HT20 ANT1 (2462MHz)

Agilent 15:55:49 Jun 16, 2015

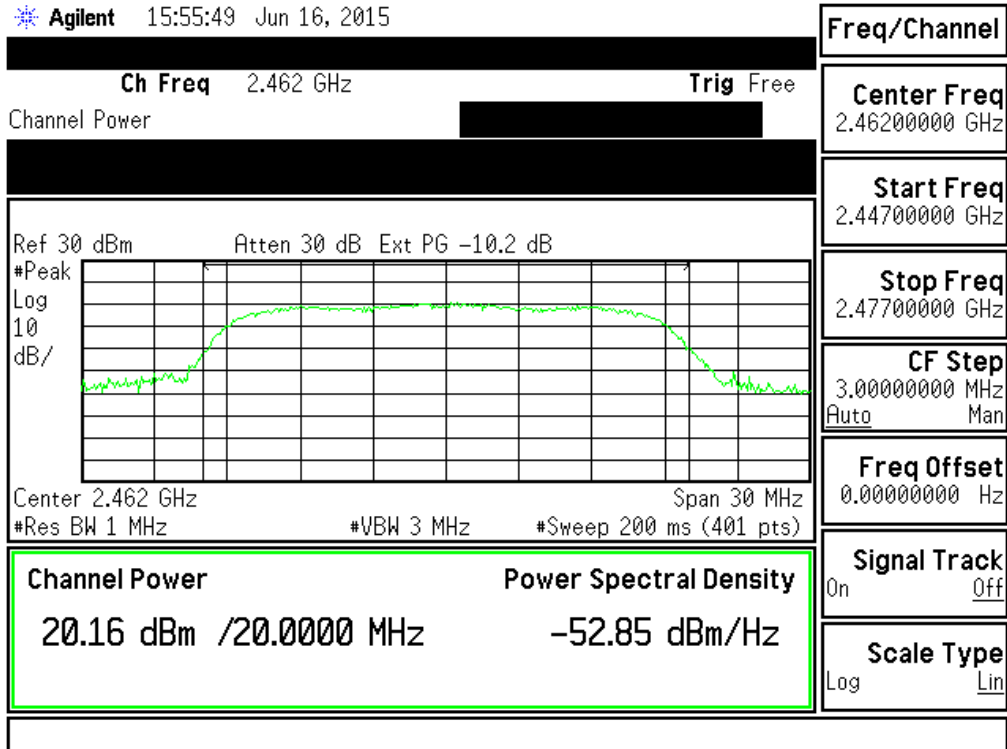

802.11HT20 ANT2 (2412MHz)

Agilent 15:30:02 Jun 16, 2015

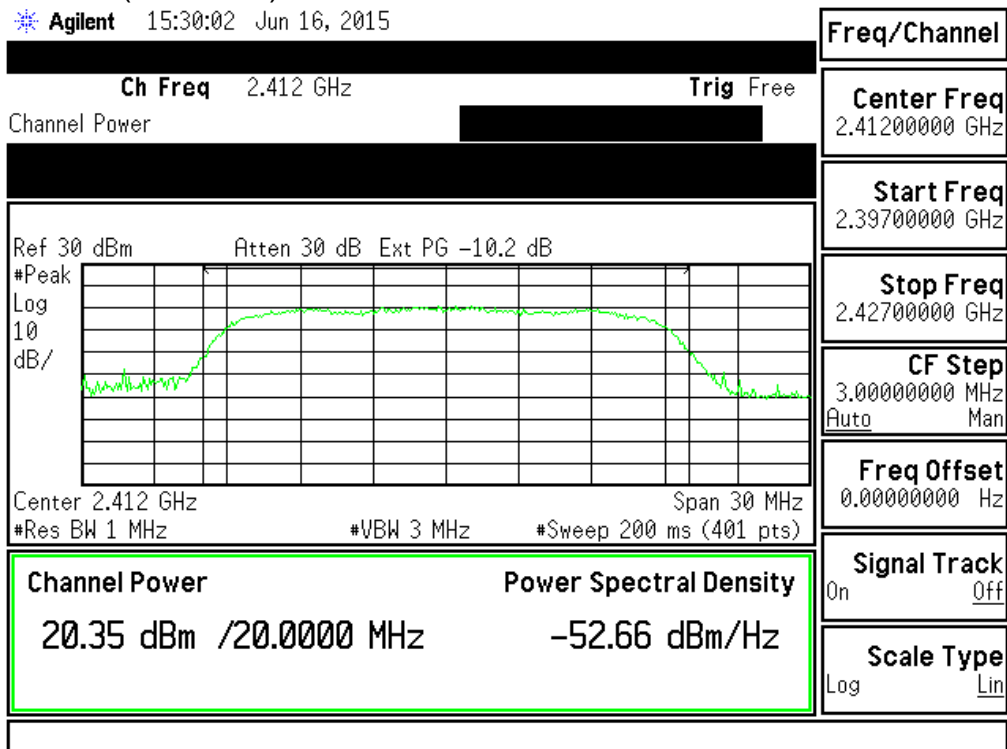

802.11HT20 ANT2 (2437MHz)

Agilent 15:46:18 Jun 16, 2015

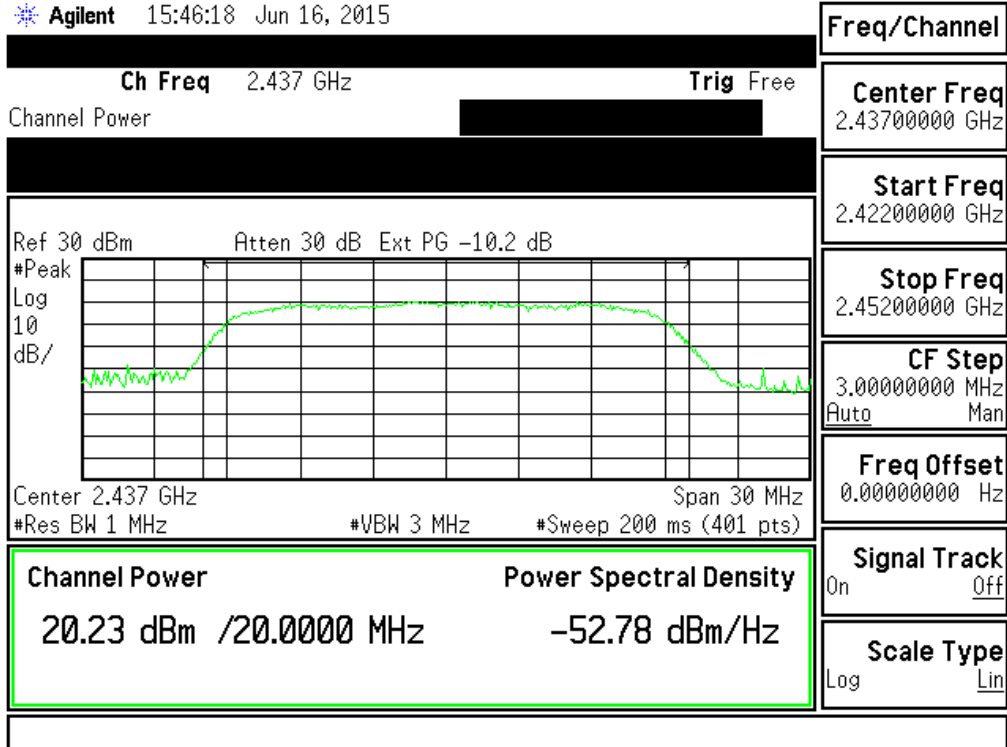

802.11HT20 ANT2 (2462MHz)

Agilent 15:56:12 Jun 16, 2015

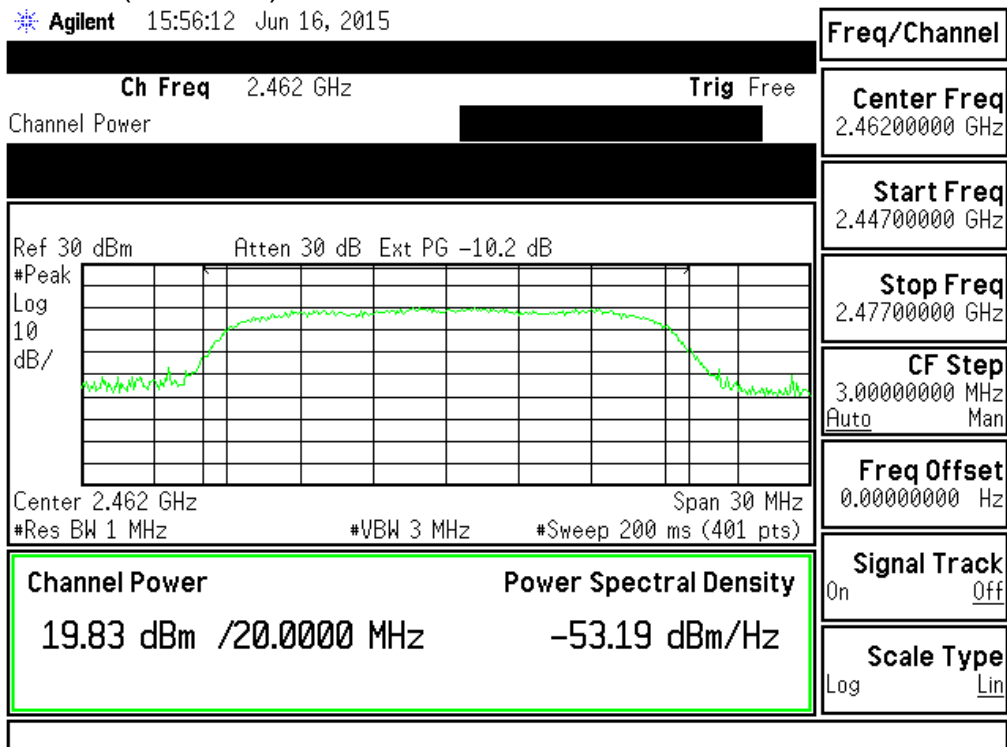

802.11HT40 ANT1 (2422MHz)

Agilent 17:29:50 Jun 16, 2015

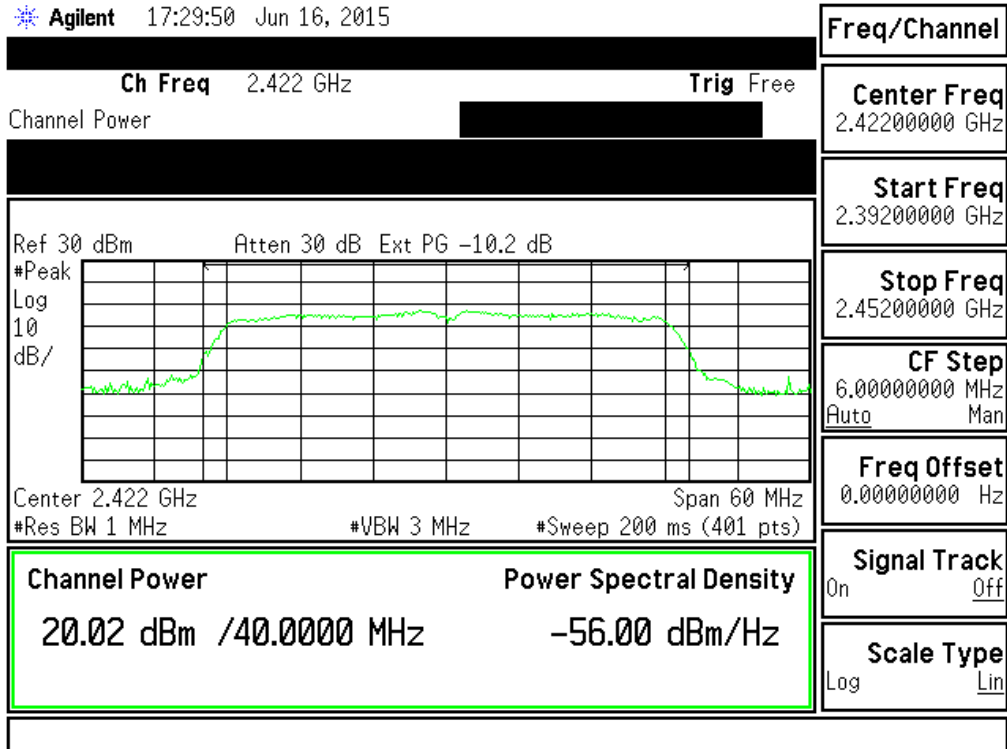

802.11HT40 ANT1 (2437MHz)

Agilent 17:36:46 Jun 16, 2015

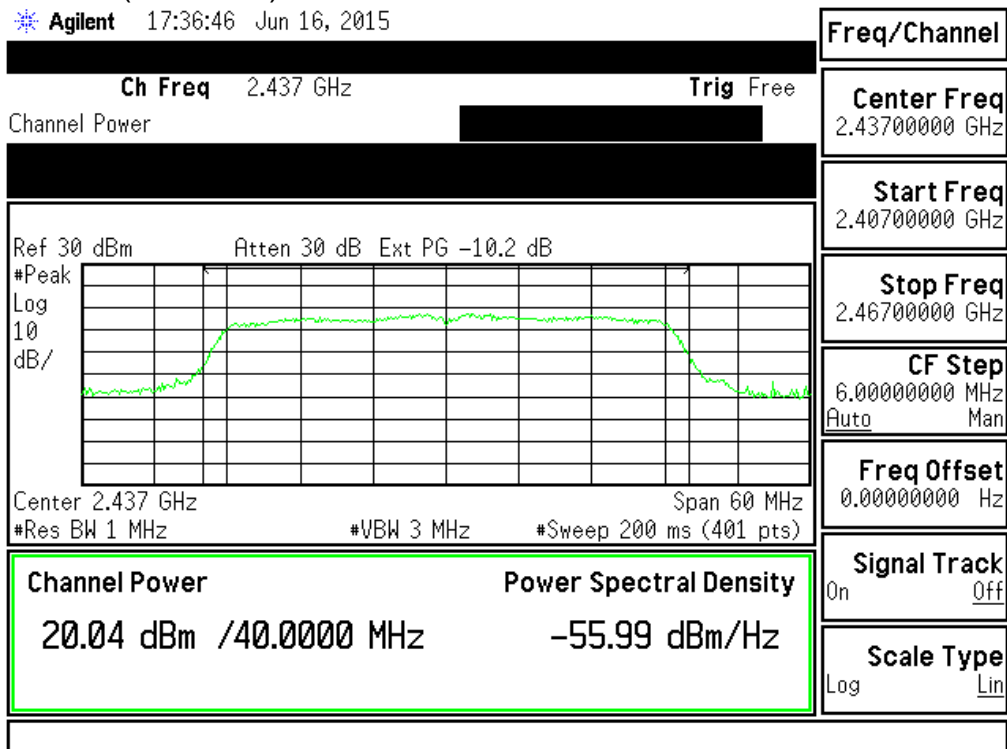

802.11HT40 ANT1 (2452MHz)

Agilent 17:45:48 Jun 16, 2015

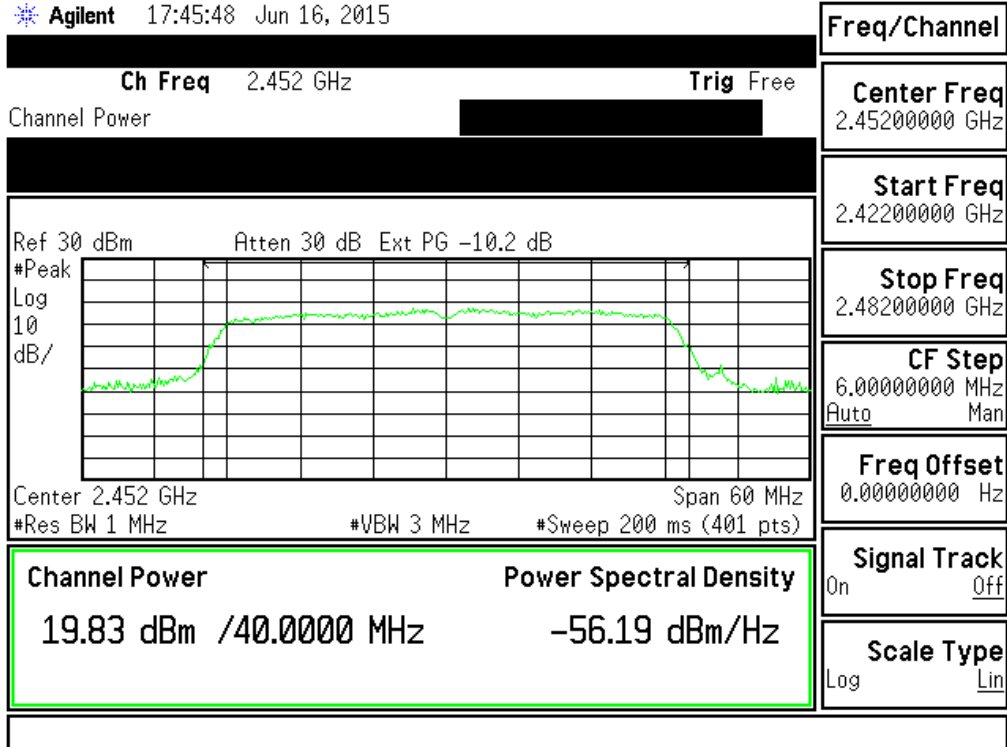

802.11HT40 ANT2 (2422MHz)

Agilent 17:29:24 Jun 16, 2015

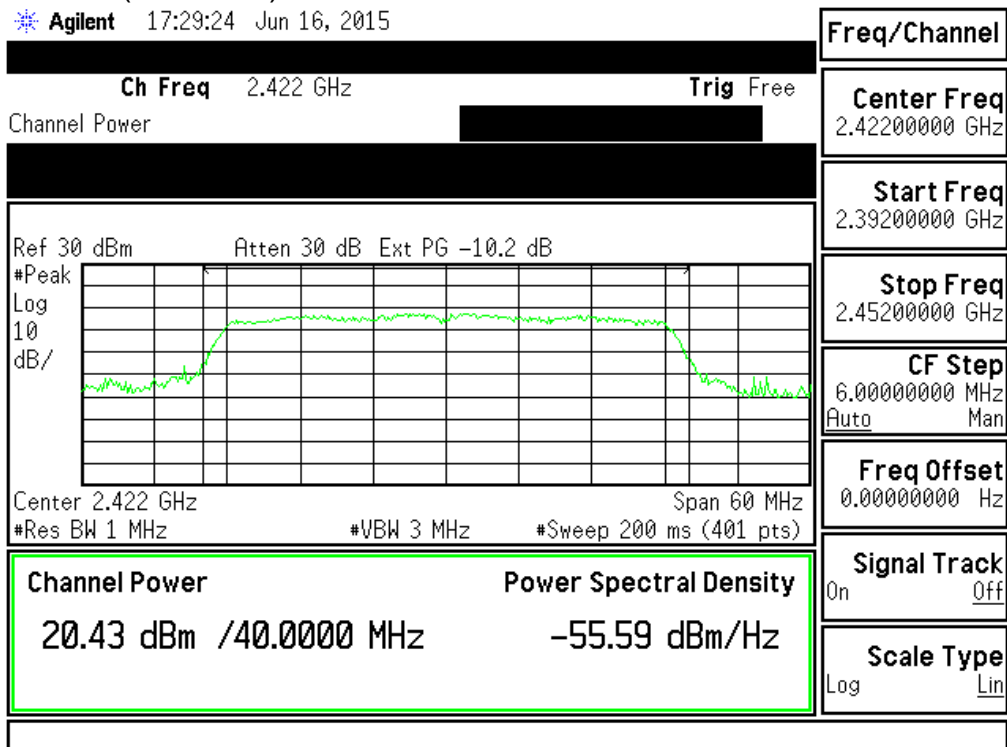

802.11HT40 ANT2 (2437MHz)

Agilent 17:36:25 Jun 16, 2015

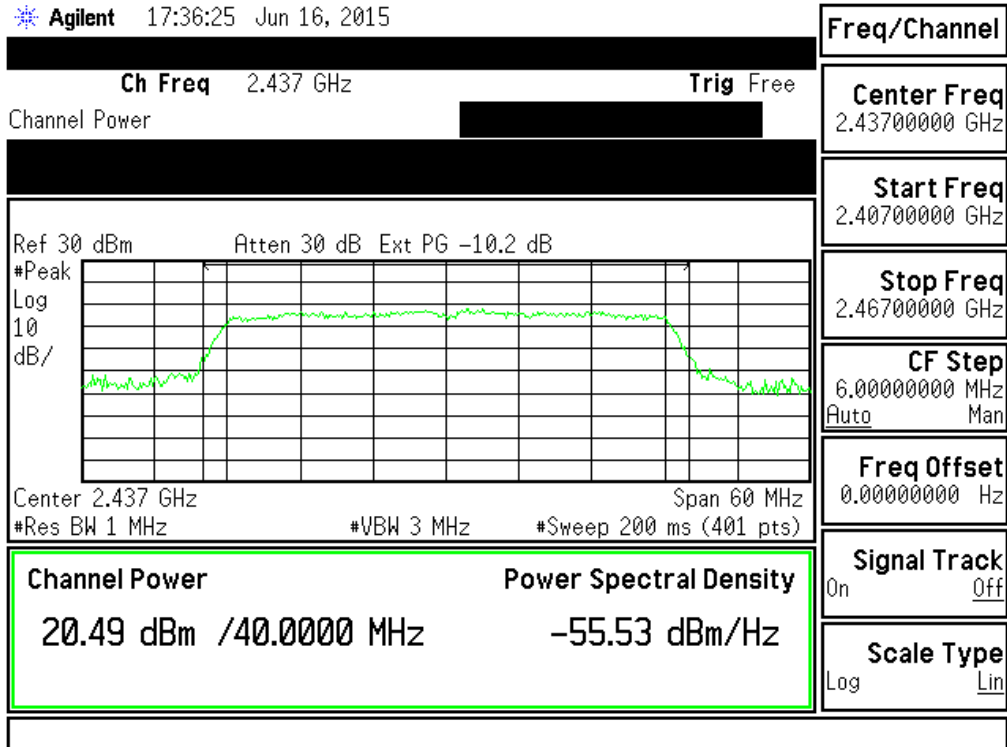

802.11HT40 ANT2 (2452MHz)

Agilent 17:45:24 Jun 16, 2015

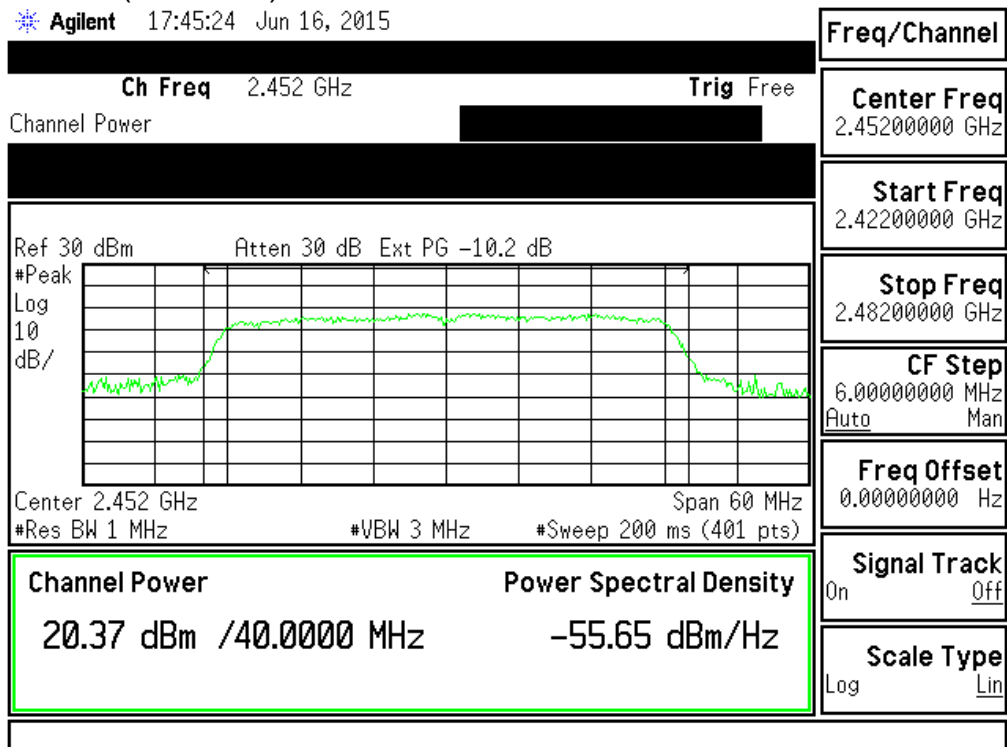

5. Minimum 6dB RF Bandwidth Requirements

5.1 Test Condition & Setup :

The antenna port of the EUT was connected to the input of a spectrum analyzer. Analyzer RES BW was set to 100 kHz. For each RF output channel investigated, the spectrum analyzer center frequency was set to the channel carrier. A PEAK output reading was taken, a DISPLAY line was drawn 6 dB lower than PEAK level. The 6 dB bandwidth was determined from where the channel output spectrum intersected the display line.

The test was performed at 3 channels (Channel 1, 6, 11). HT40(Channel 3, 6, 9).

Measurement procedure is followed KDB 558074 v03r04 (8.1 option 1: DTS bandwidth)

5.2 Test Instruments Configuration:

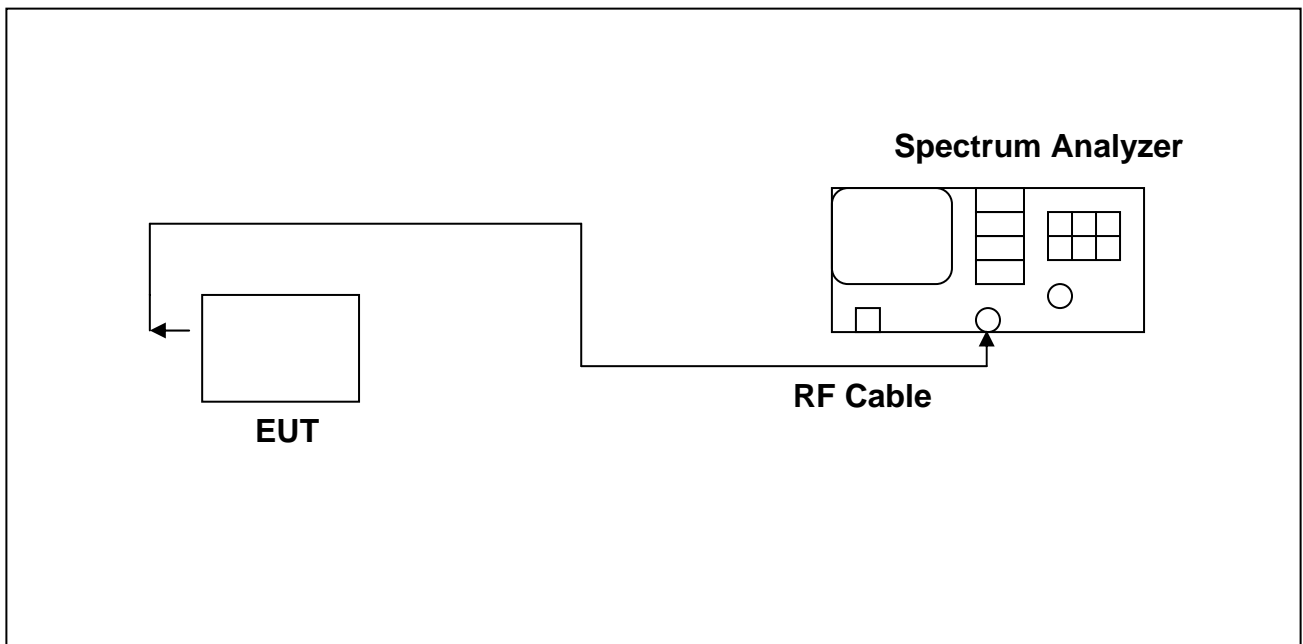

5.3 Test Equipment List:

Item	Mfr/Brand	Instruments	Serial No.	Model/Type No.	Calibrated Date	Next Cal. Date
1.	Agilent	Spectrum Analyzer	US44300422	E4446A	2015/02/04	2016/02/04

5.4 Test Result:

802.11b

Frequency (MHz)	Min. 6dB Bandwidth (MHz)	Required Limit
2412	8.625	>500KHz
2437	8.625	>500KHz
2462	8.5875	>500KHz

802.11g

Frequency (MHz)	Min. 6dB Bandwidth (MHz)	Required Limit
2412	16.000	>500KHz
2437	15.750	>500KHz
2462	15.6875	>500KHz

802.11n HT20(Ant 1)

Frequency (MHz)	Min. 6dB Bandwidth (MHz)	Required Limit
2412	16.9375	>500KHz
2437	17.250	>500KHz
2462	16.6875	>500KHz

802.11n HT40(Ant 1)

Frequency (MHz)	Min. 6dB Bandwidth (MHz)	Required Limit
2422	36.375	>500KHz
2437	36.375	>500KHz
2452	36.250	>500KHz

802.11n HT20(Ant 2)

Frequency (MHz)	Min. 6dB Bandwidth (MHz)	Required Limit
2412	17.250	>500KHz
2437	17.250	>500KHz
2462	17.1875	>500KHz

802.11n HT40(Ant 2)

Frequency (MHz)	Min. 6dB Bandwidth (MHz)	Required Limit
2422	36.500	>500KHz
2437	36.500	>500KHz
2452	36.375	>500KHz

Note: Test Graphs See next page.

802.11b (2412MHz)

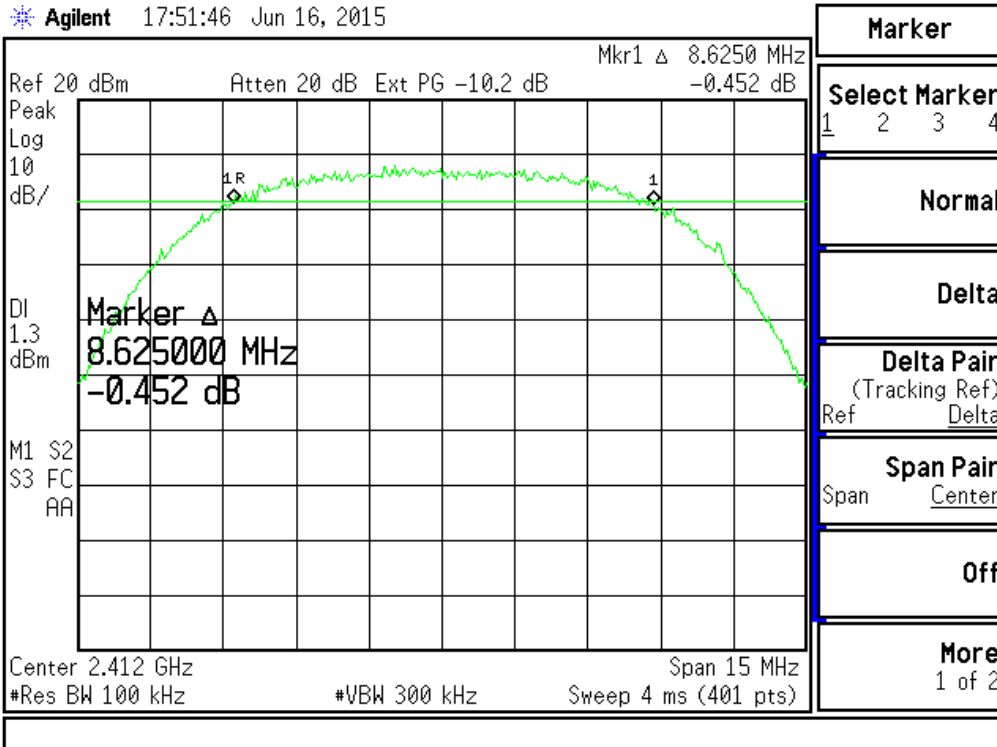

Note: Ext PG = Attenuator + Cable loss.

802.11b (2437MHz)

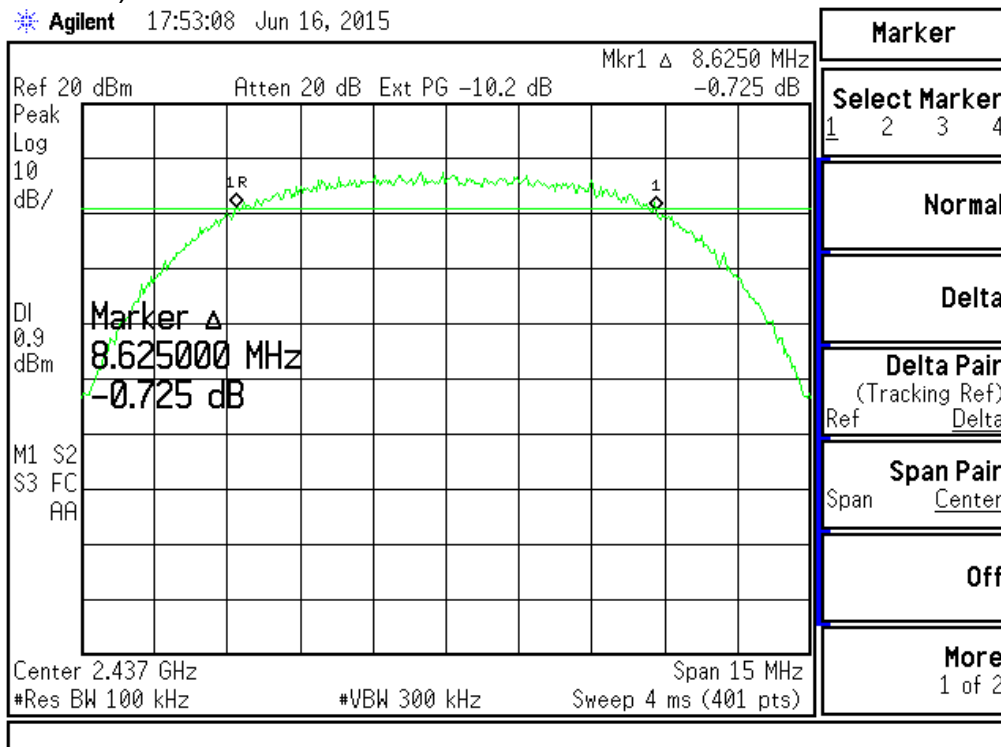

802.11b (2462MHz)

Agilent 17:54:39 Jun 16, 2015

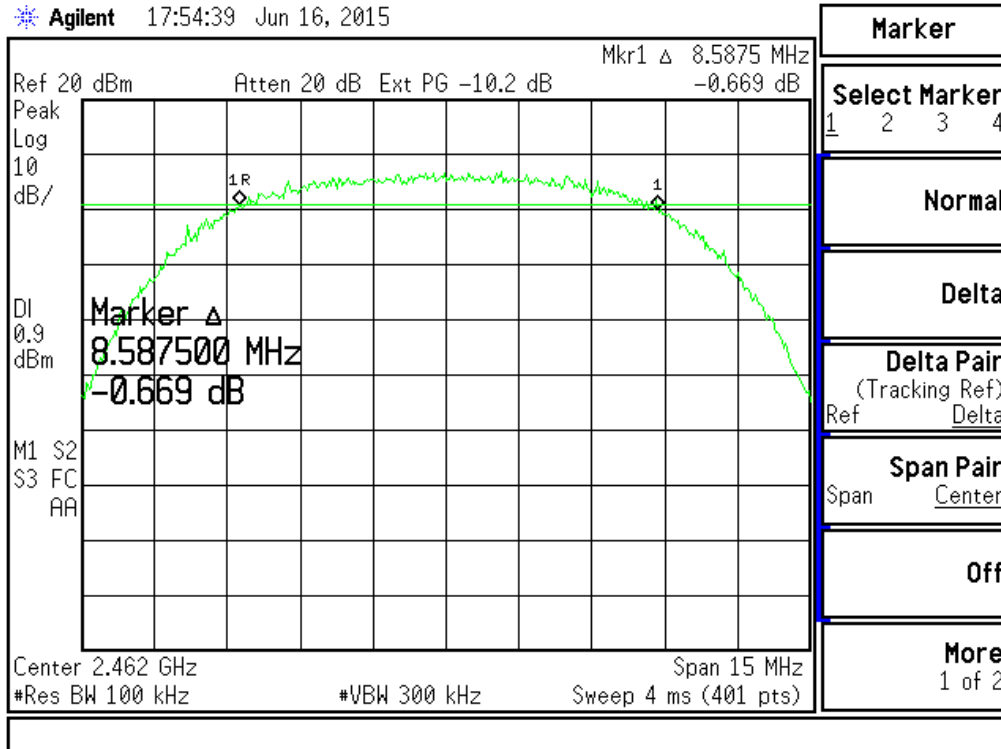

802.11g (2412MHz)

Agilent 17:56:33 Jun 16, 2015

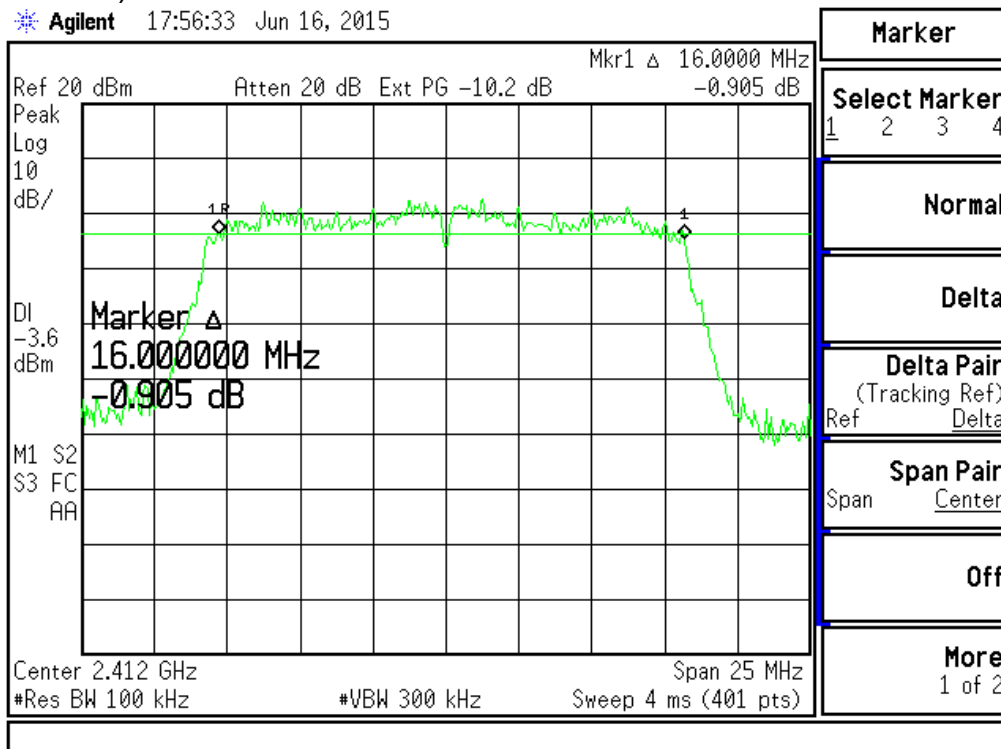

802.11g (2437MHz)

Agilent 17:57:50 Jun 16, 2015

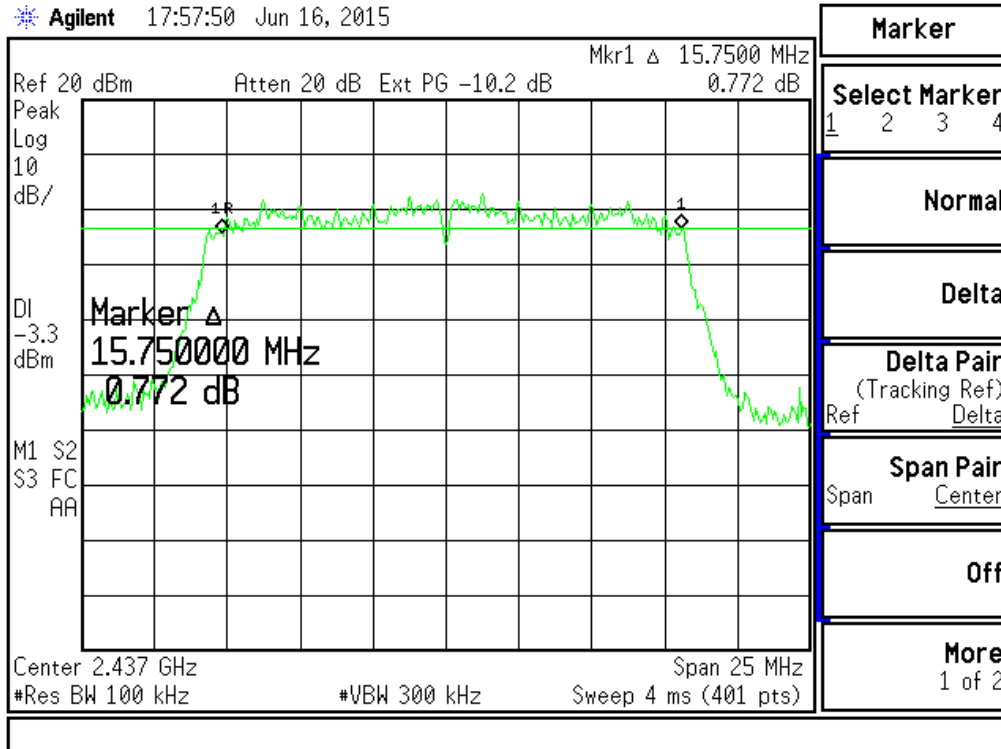

802.11g (2462MHz)

Agilent 17:59:03 Jun 16, 2015

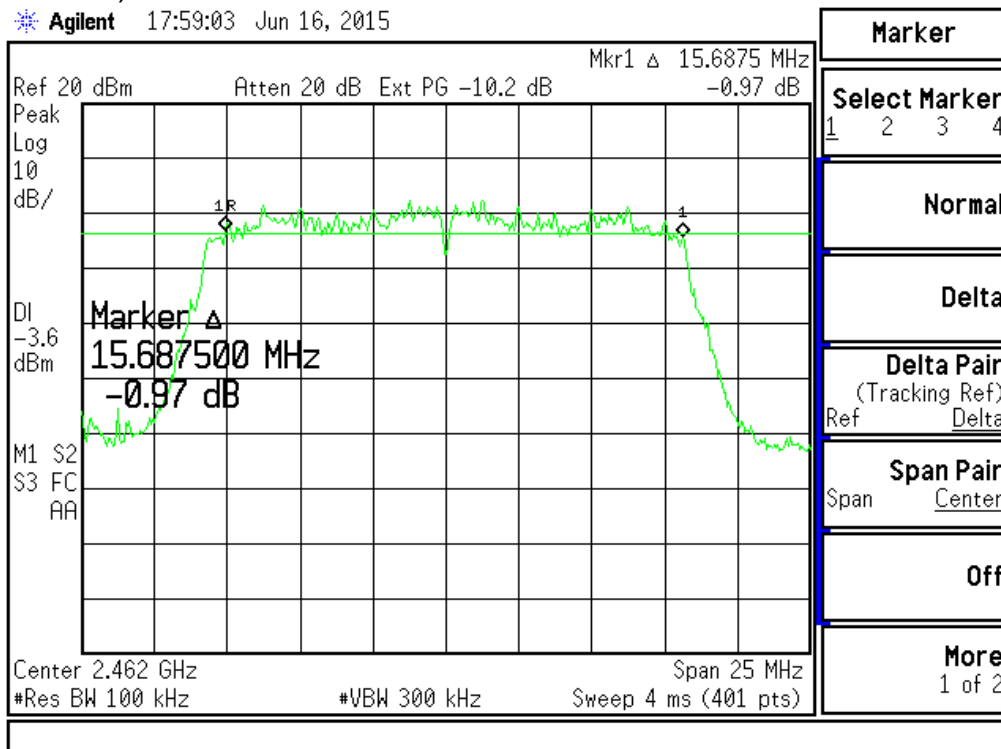

802.11n HT20(Ant 1)(2412MHz)

Agilent 18:00:29 Jun 16, 2015

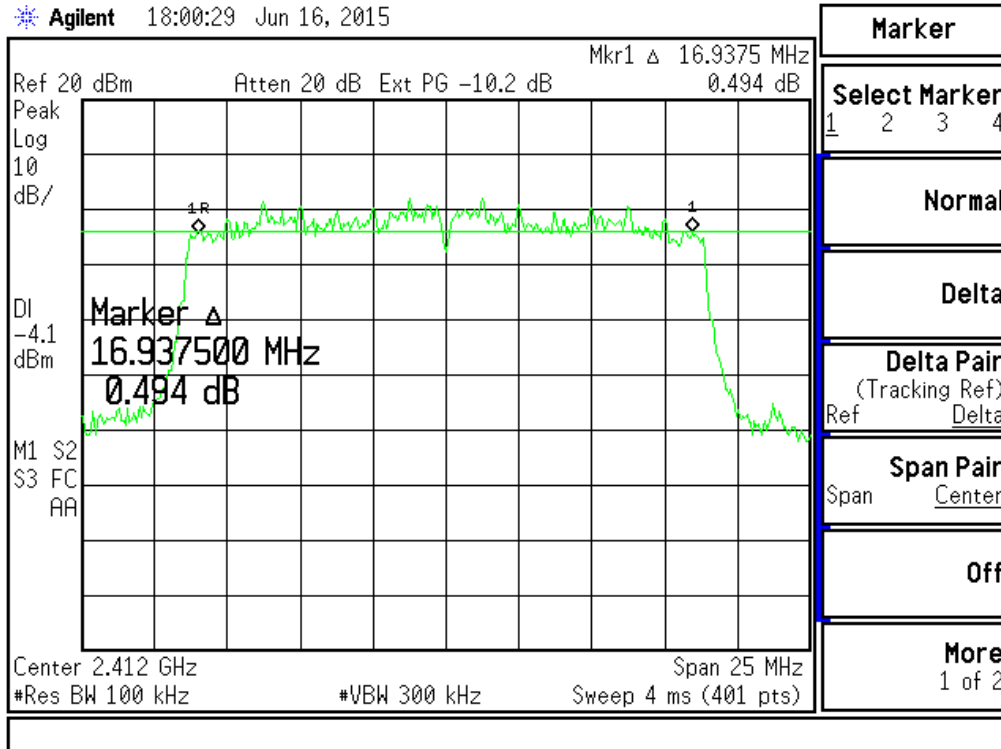

802.11n HT20(Ant 1)(2437MHz)

Agilent 18:05:02 Jun 16, 2015

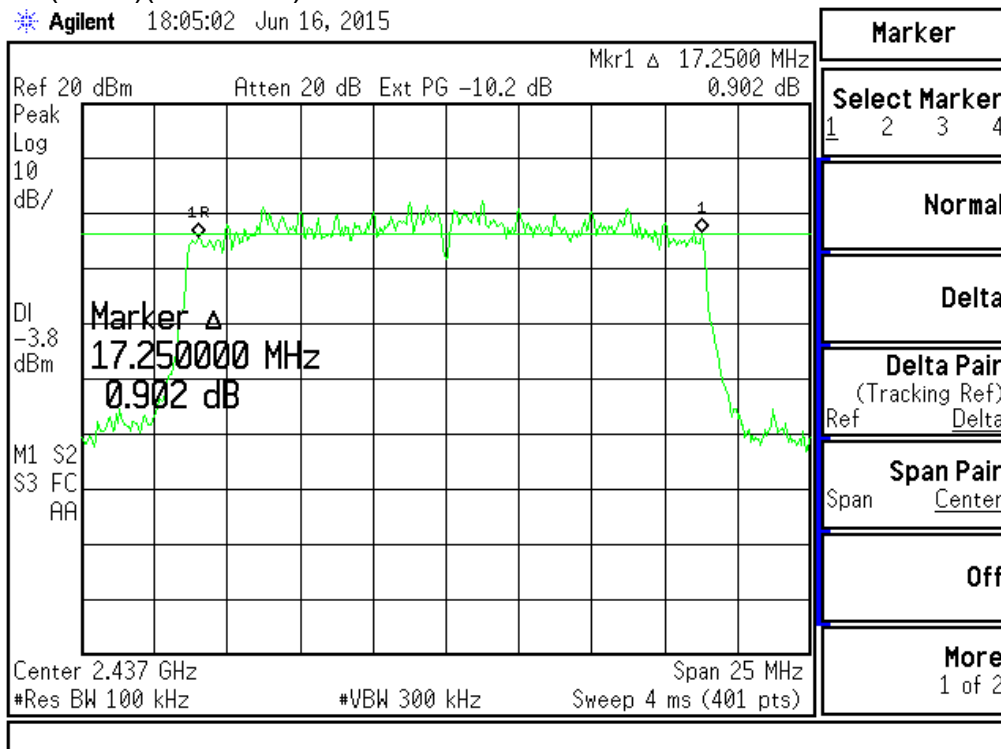

802.11n HT20(Ant 1)(2462MHz)

Agilent 18:08:15 Jun 16, 2015

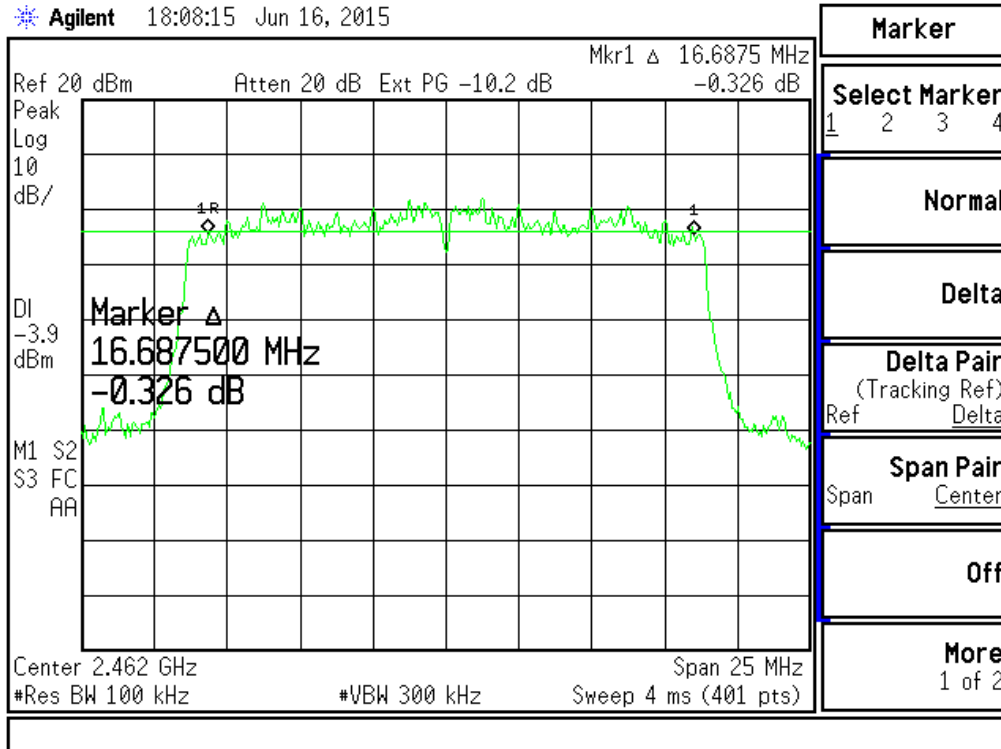

802.11n HT40(Ant 1)(2422MHz)

Agilent 18:11:12 Jun 16, 2015

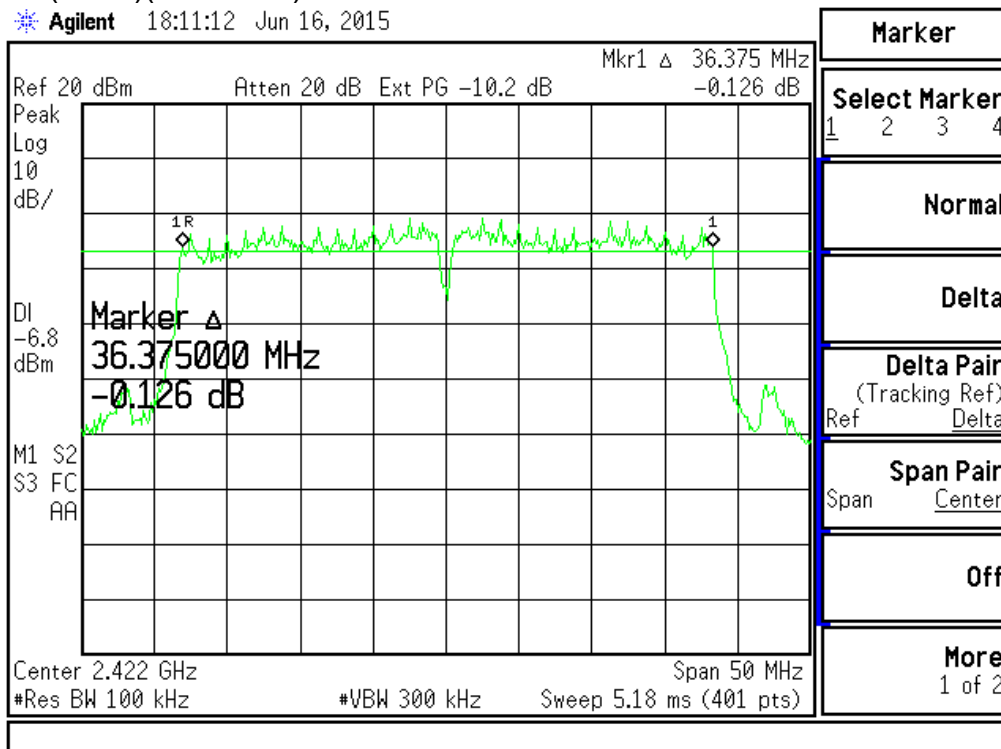

802.11n HT40(Ant 1) (2437MHz)

Agilent 18:14:57 Jun 16, 2015

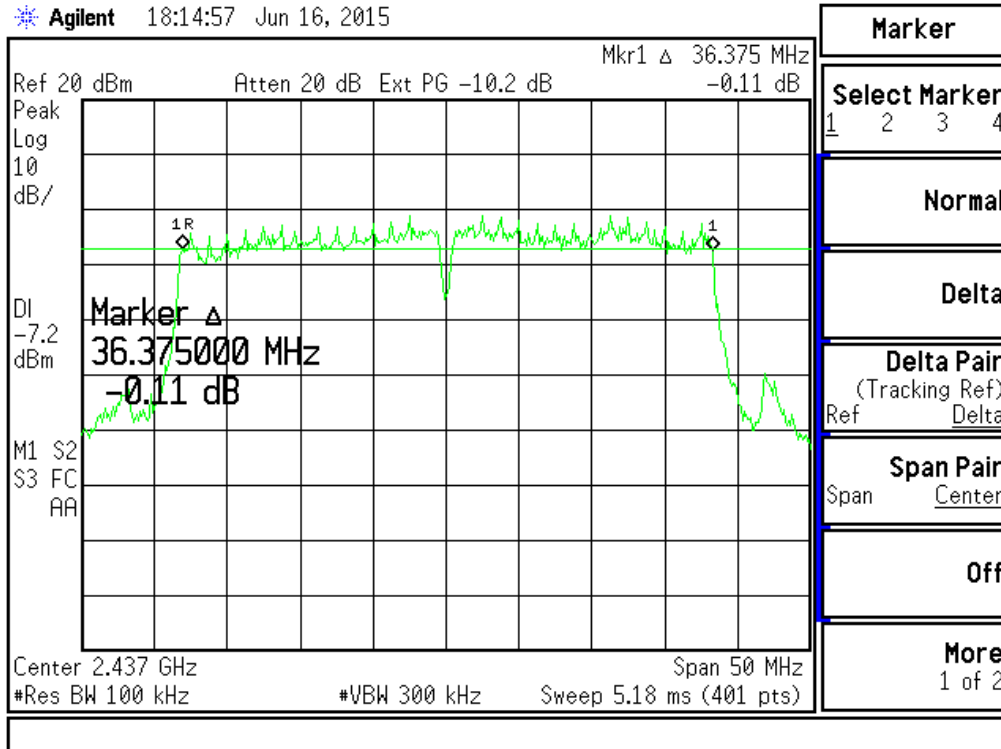

802.11n HT40(Ant 1) (2452MHz)

Agilent 18:16:39 Jun 16, 2015

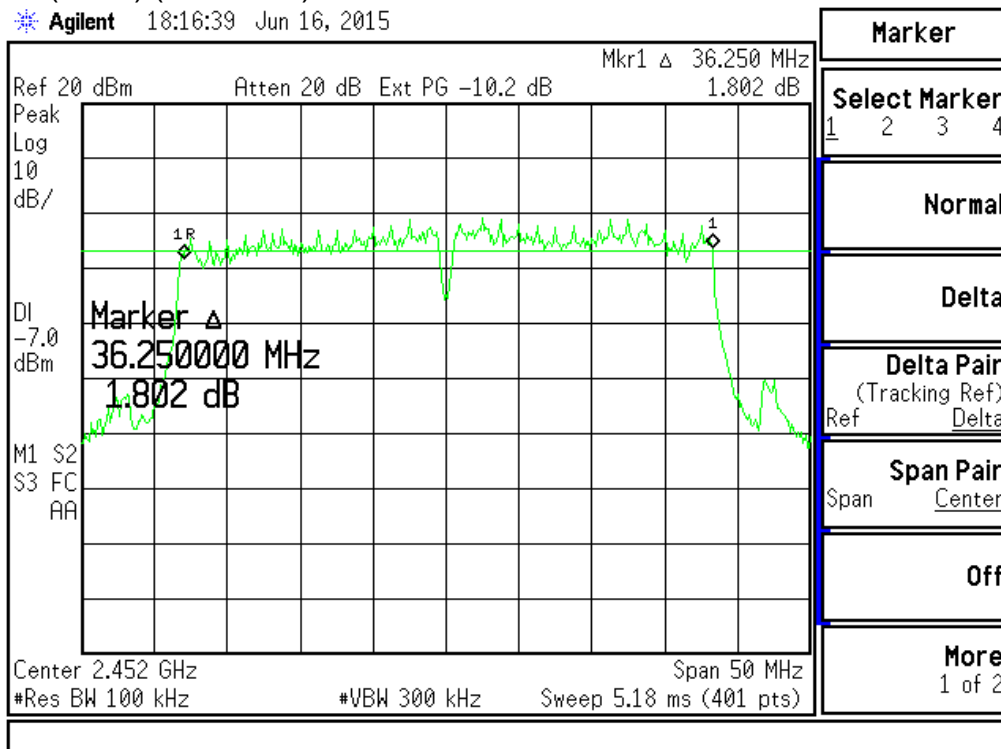

802.11n HT20(Ant 2)(2412MHz)

Agilent 18:01:41 Jun 16, 2015

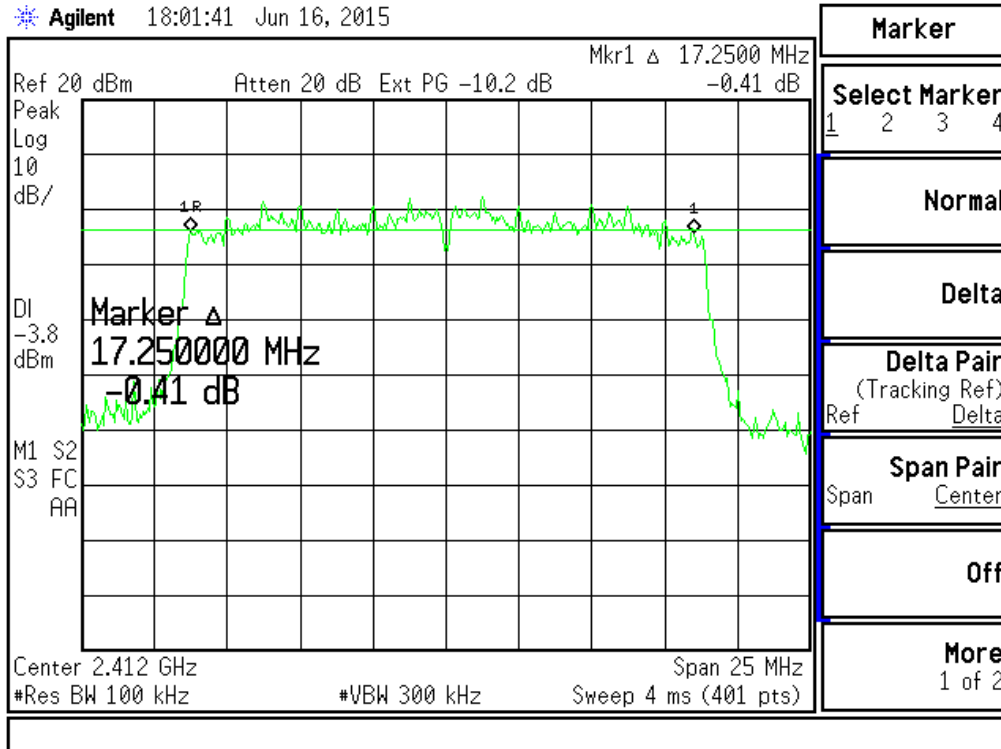

802.11n HT20(Ant 2)(2437MHz)

Agilent 18:03:18 Jun 16, 2015

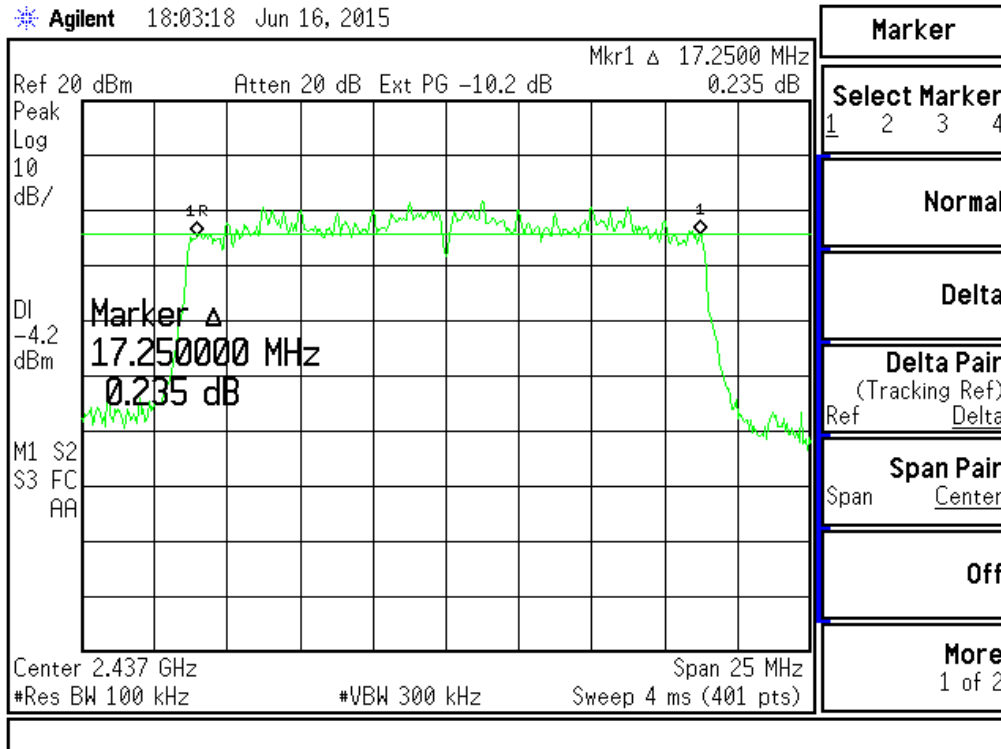

802.11n HT20(Ant 2)(2462MHz)

Agilent 18:09:29 Jun 16, 2015

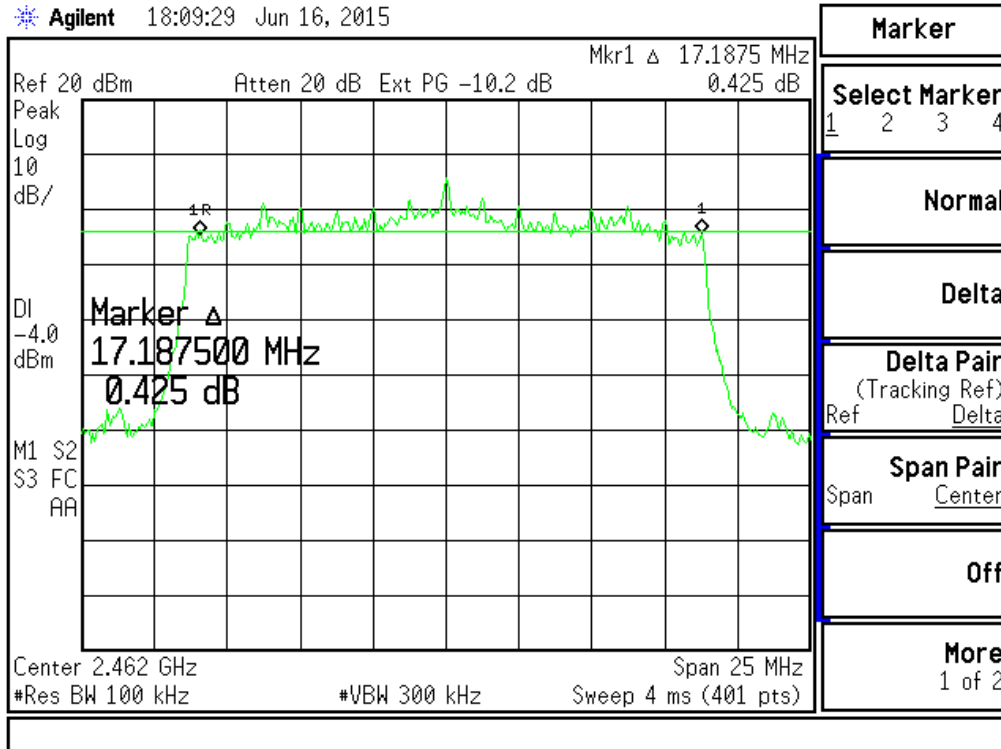

802.11n HT40(Ant 2)(2422MHz)

Agilent 18:12:25 Jun 16, 2015

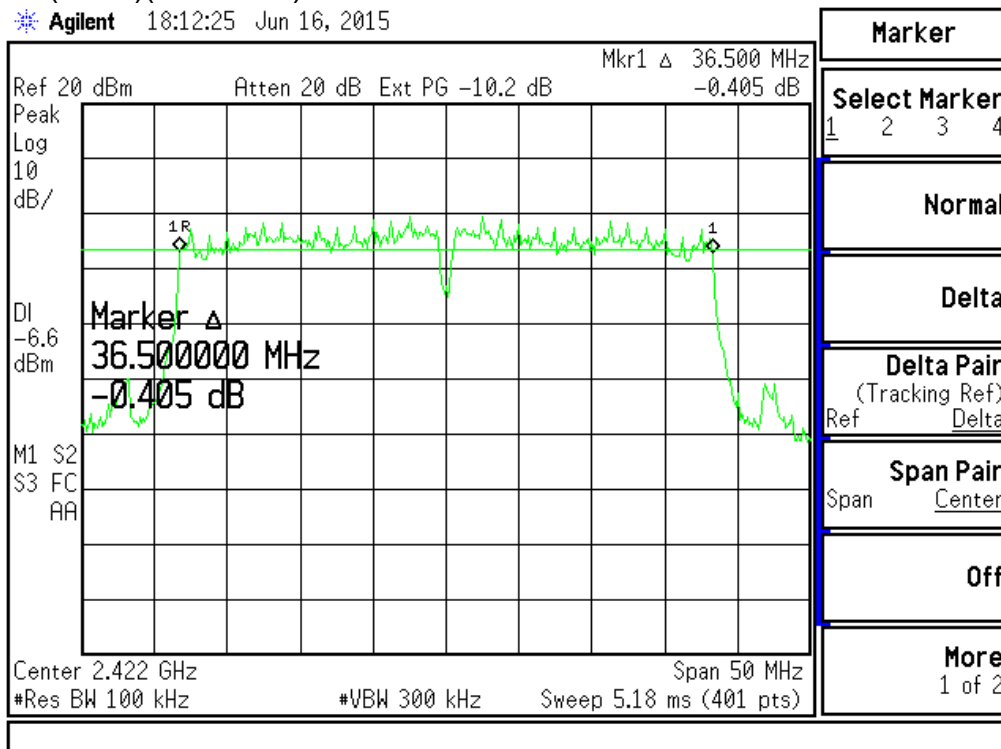

802.11n HT40(Ant 2)(2437MHz)

Agilent 18:13:47 Jun 16, 2015

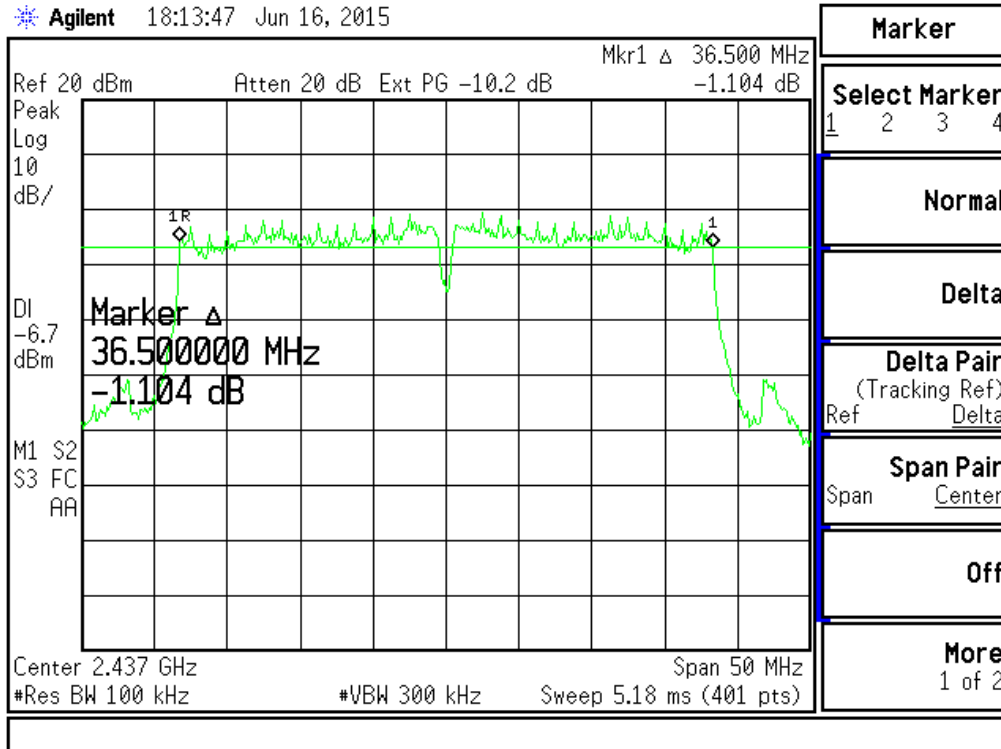

802.11n HT40(Ant 2)(2452MHz)

Agilent 18:17:45 Jun 16, 2015

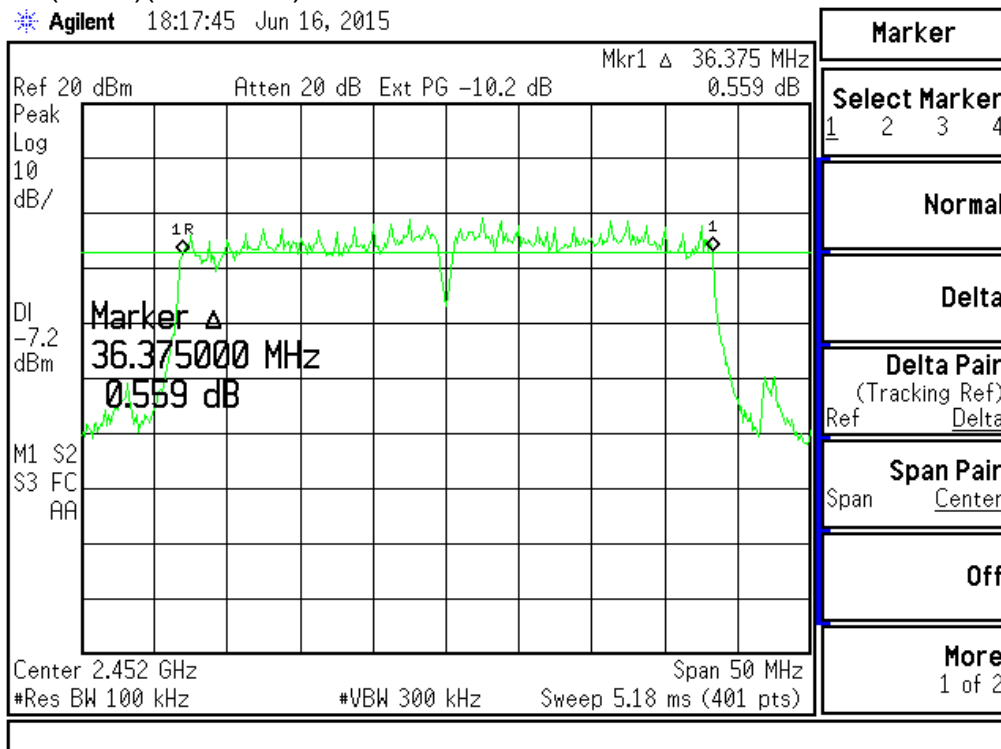

6. Maximum Power Density Requirements

6.1 Test Condition & Setup :

For digitally modulated systems, the power spectral density conducted from the intentional radiator to the antenna shall not be greater than 8 dBm in any 3 kHz band during any time interval of continuous transmission.

RBW =3kHz , VBW=10kHz ,

Detector = peak , Sweep time = auto couple , Trace Mode = max hold , Allow trace to fully stabilize. Use the peak marker function to determine the maximum amplitude level in any 3kHz band segment within the fundamental EBW.

Measurement procedure is followed KDB 558074 v03r04 (10.2 Method PKPSD (peak PSD)

Measurement procedure is followed KDB 662911 D01 Multiple Transmitter Output v02 Paragraph E) Guidance for summing emission measurements from multiple outputs of a transmitter or from multiple transmitters.

2) In-Band Power Spectral Density (PSD) Measurements

- a) Measure and sum the spectra across the outputs.
- b) Measure and sum spectral maxima across the outputs.
- c) add $10 \log(Nant)$ dB .

6.2 Test Instruments Configuration:

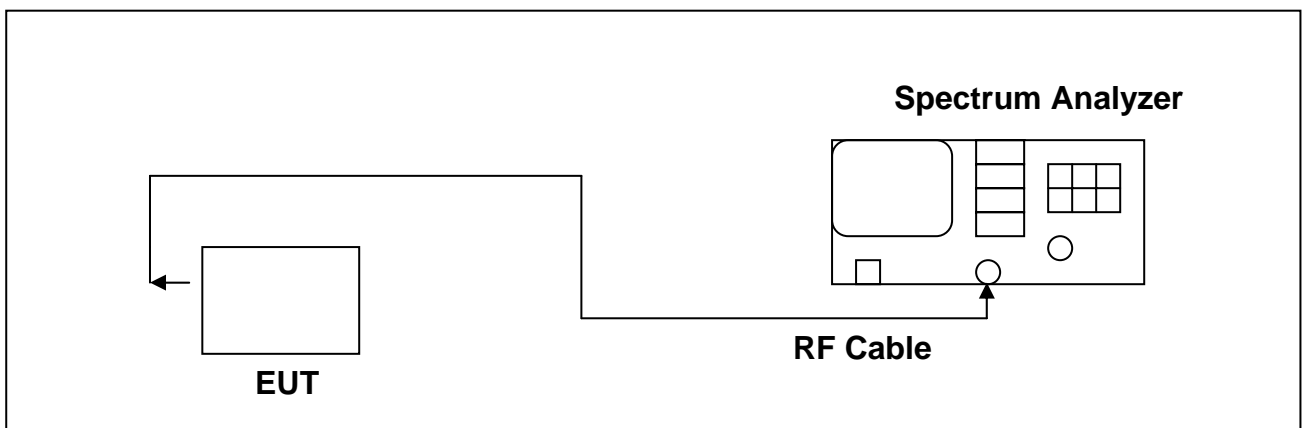

6.3 Test Equipment List:

Item	Mfr/Brand	Instruments	Serial No.	Model/Type No.	Calibrated Date	Next Cal. Date
1.	Agilent	Spectrum Analyzer	US44300422	E4446A	2015/02/04	2016/02/04

6.4 Test Result:

802.11b

Frequency (MHz)	Power Density (dBm)	Power Density (mW)
2412	-6.842	<8dBm
2437	-6.895	<8dBm
2462	-5.999	<8dBm

802.11g

Frequency (MHz)	Power Density (dBm)	Power Density (mW)
2412	-12.060	<8dBm
2437	-11.780	<8dBm
2462	-12.310	<8dBm

802.11n HT20(Ant 1)

Frequency (MHz)	Power Density (dBm)	Power Density (mW)	Required Limit
2412	-11.400	0.03622	<8dBm
2437	-11.060	0.03917	<8dBm
2462	-11.510	0.03532	<8dBm

Note : Power Density = spectrum measurements value + 10log(Nant)
Number of antenna: 2 → 10log(2)=3.01dB

802.11n HT40(Ant 1)

Frequency (MHz)	Power Density (dBm)	Power Density (mW)	Required Limit
2422	-14.670	0.01706	<8dBm
2437	-15.930	0.01276	<8dBm
2452	-16.110	0.01225	<8dBm

Note : Power Density = spectrum measurements value + 10log(Nant)
Number of antenna: 2 → 10log(2)=3.01dB

802.11n HT20(Ant 2)

Frequency (MHz)	Power Density (dBm)	Power Density (mW)	Required Limit
2412	-12.230	0.02992	<8dBm
2437	-11.960	0.03184	<8dBm
2462	-12.290	0.02951	<8dBm

Note : Power Density = spectrum measurements value + 10log(Nant)
Number of antenna: 2 → 10log(2)=3.01dB

802.11n HT40(Ant 2)

Frequency (MHz)	Power Density (dBm)	Power Density (mW)	Required Limit
2422	-15.220	0.01503	<8dBm
2437	-15.740	0.01334	<8dBm
2452	-14.190	0.01905	<8dBm

Note : Power Density = spectrum measurements value + 10log(Nant)
Number of antenna: 2 → 10log(2)=3.01dB

Note : The graph shown below is the highest output power of all different frequency listed in the table above..

802.11b (2462MHz)

Agilent 09:02:54 Jun 17, 2015

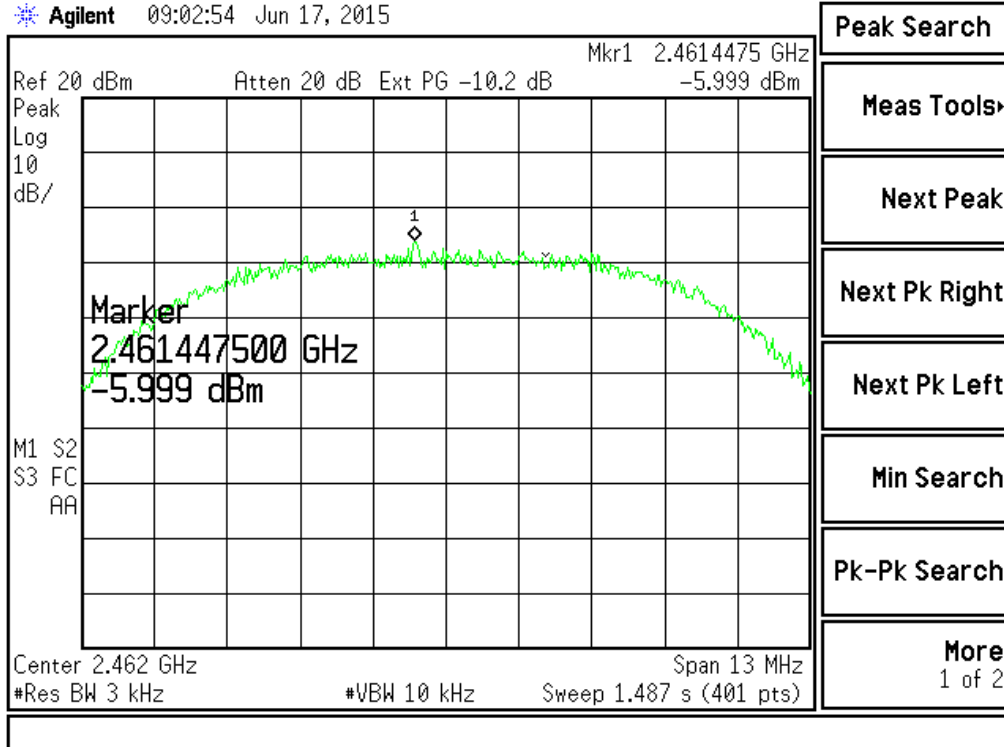

Note: Ext PG = Attenuator + Cable loss.

802.11g (2437MHz)

Agilent 09:05:16 Jun 17, 2015

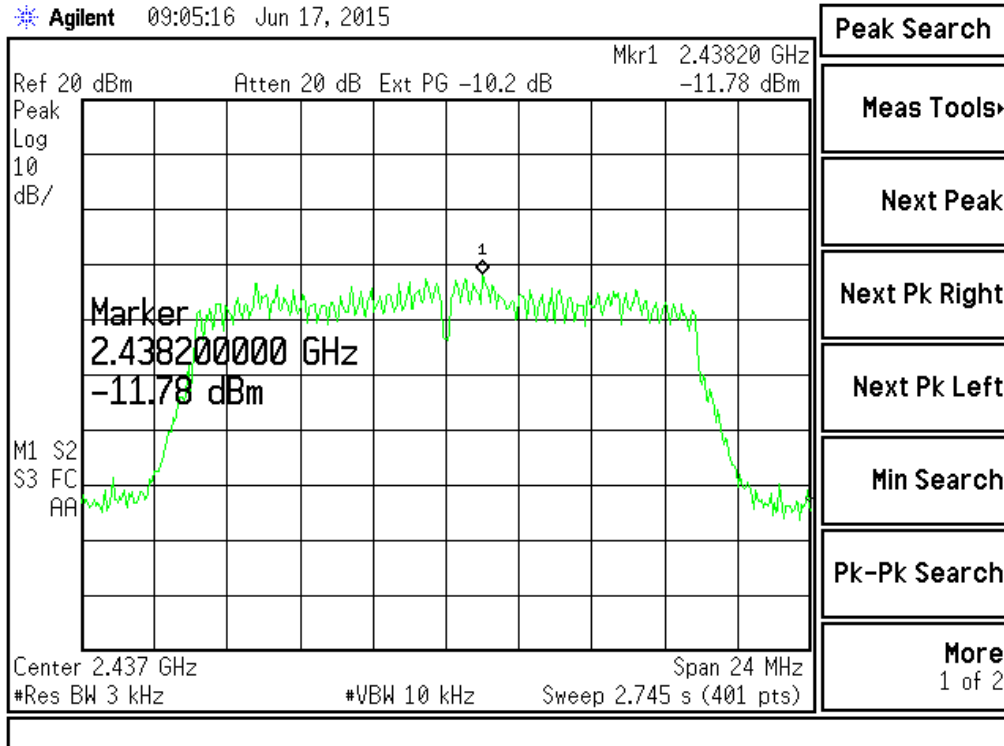

802.11n HT20(Ant 1)(2437MHz)

Agilent 09:11:11 Jun 17, 2015

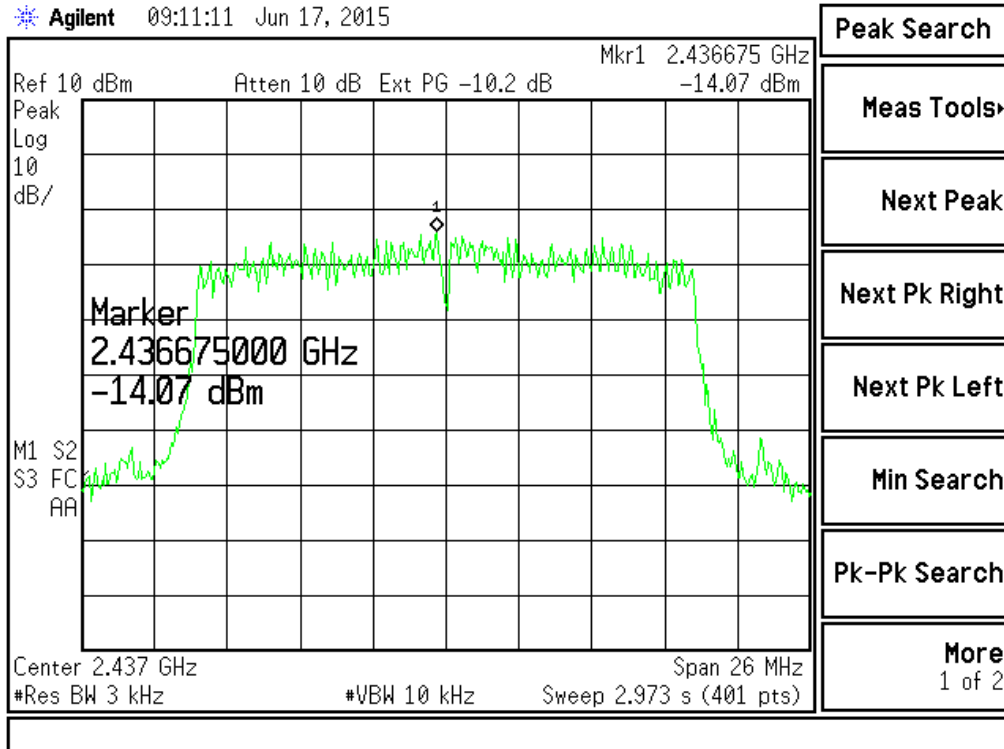

802.11n HT40(Ant 1)(2422MHz)

Agilent 09:14:15 Jun 17, 2015

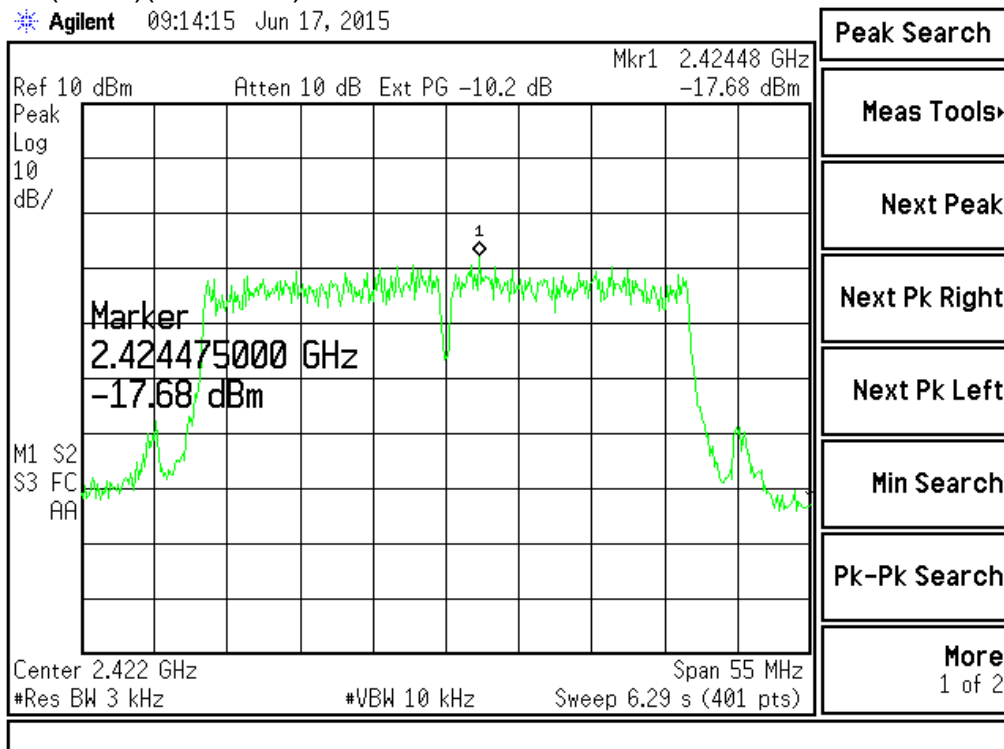

802.11n HT20(Ant 2)(2437MHz)

Agilent 09:10:26 Jun 17, 2015

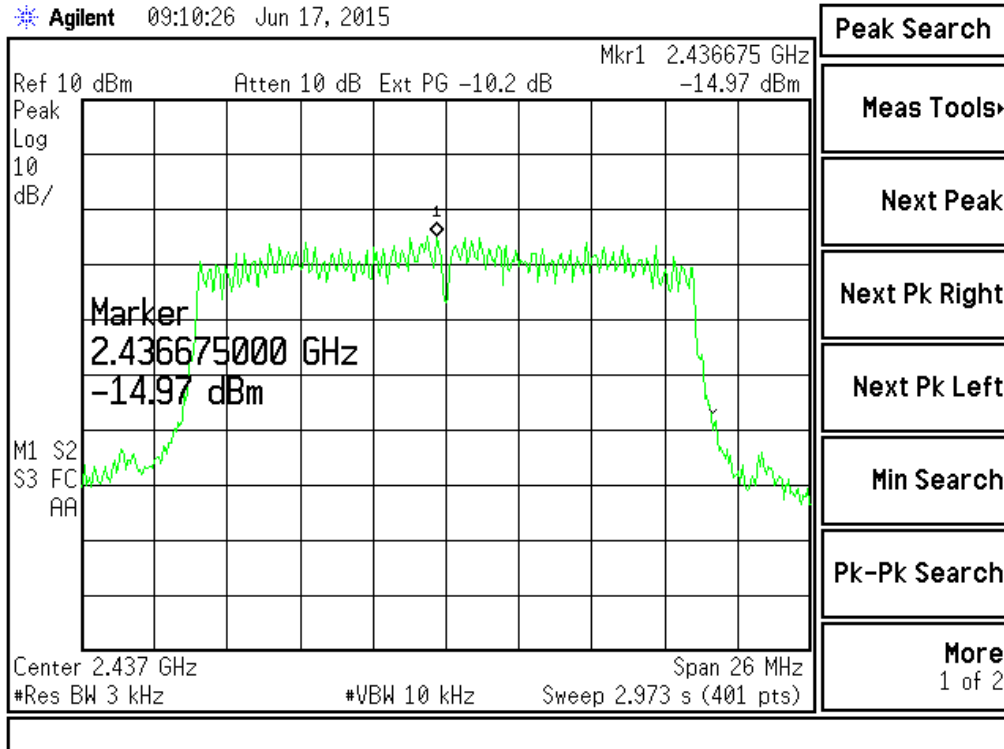

802.11n HT40(Ant 2)(2452MHz)

Agilent 09:21:17 Jun 17, 2015

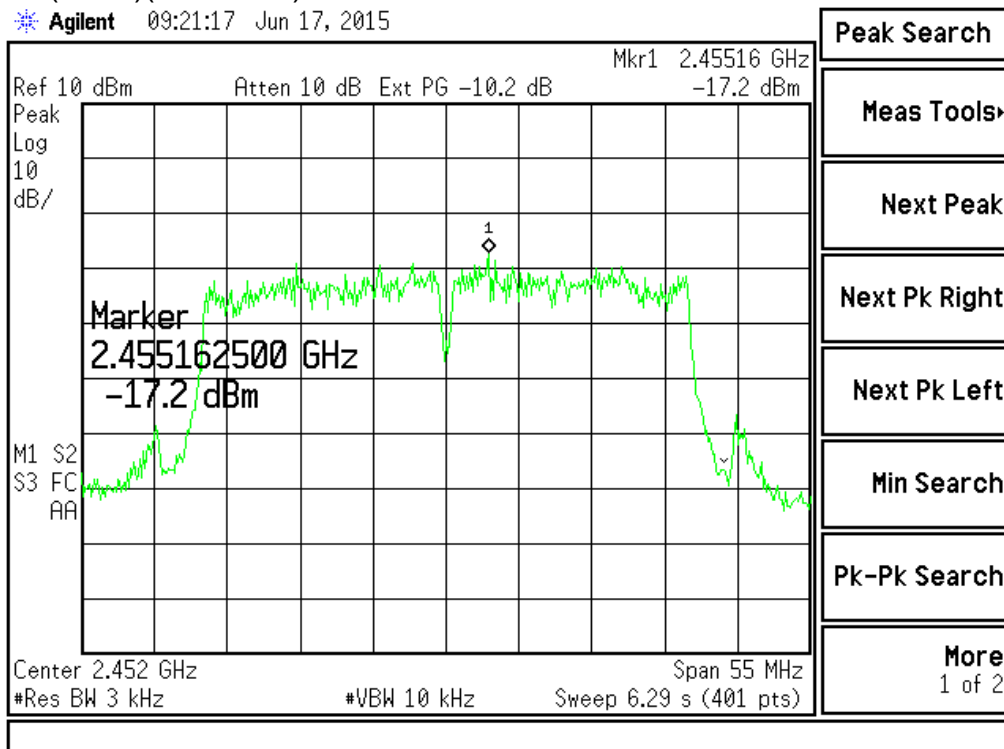

7. Out of Band Conducted Spurious Emissions Requirements

7.1 Test Condition & Setup :

In any 100 kHz bandwidth outside the EUT pass band, the RF power produced by the modulation products of the spreading sequence, the information sequence, and the carrier frequency shall be at least 20 dB below that of the maximum in-band 100 kHz emission, antenna output of the EUT was coupled directly to spectrum analyzer; if an external attenuator and/or cable was used, these losses are compensated for with the analyzer OFFSET function.

All other types of emissions from the EUT shall meet the general limits for radiated frequencies outside the pass band. The test was performed at 3 channels.

Measurement procedure is followed KDB 558074 v03r04 (11.3 Emission level measurement)

7.2 Test Instruments Configuration:

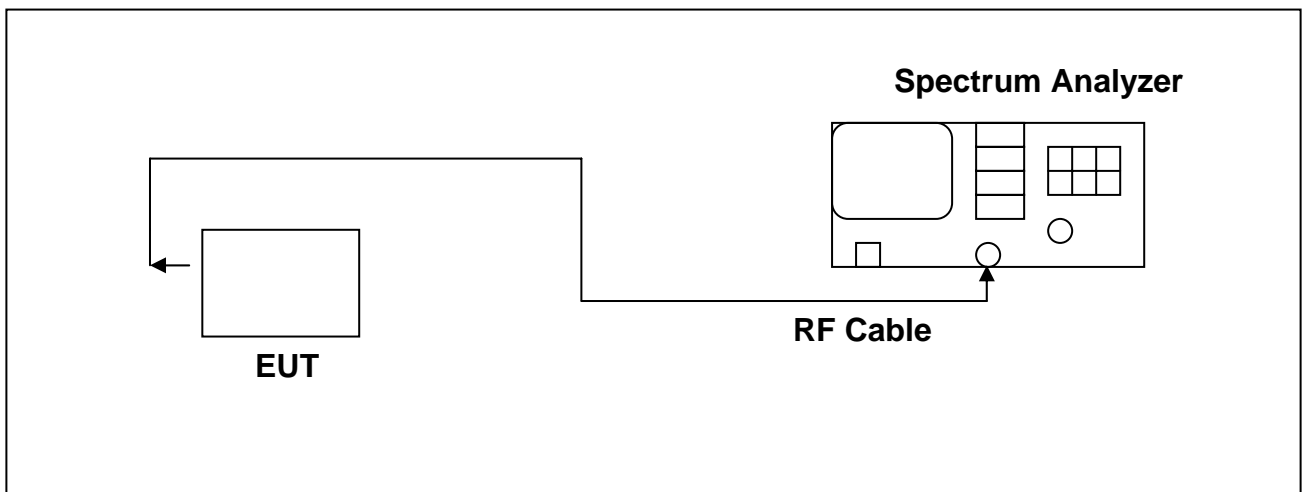

7.3 Test Equipment List:

Item	Mfr/Brand	Instruments	Serial No.	Model/Type No.	Calibrated Date	Next Cal. Date
1.	Agilent	Spectrum Analyzer	US44300422	E4446A	2015/02/04	2016/02/04

7.4 Test Result:

Refer to attached data sheets. Data shows out of band emissions are suppressed well below the -20 dBc minimum required by the Rules.

For the MIMO result, if the spurious emission of two antennas have the same frequency, we choose the worst one and add 3dB to be the final result, otherwise, use the graph to represent it.

Note : Test Graphs See next page.

802.11b (CH01) (1 of 2)

Agilent 10:28:35 Jun 17, 2015

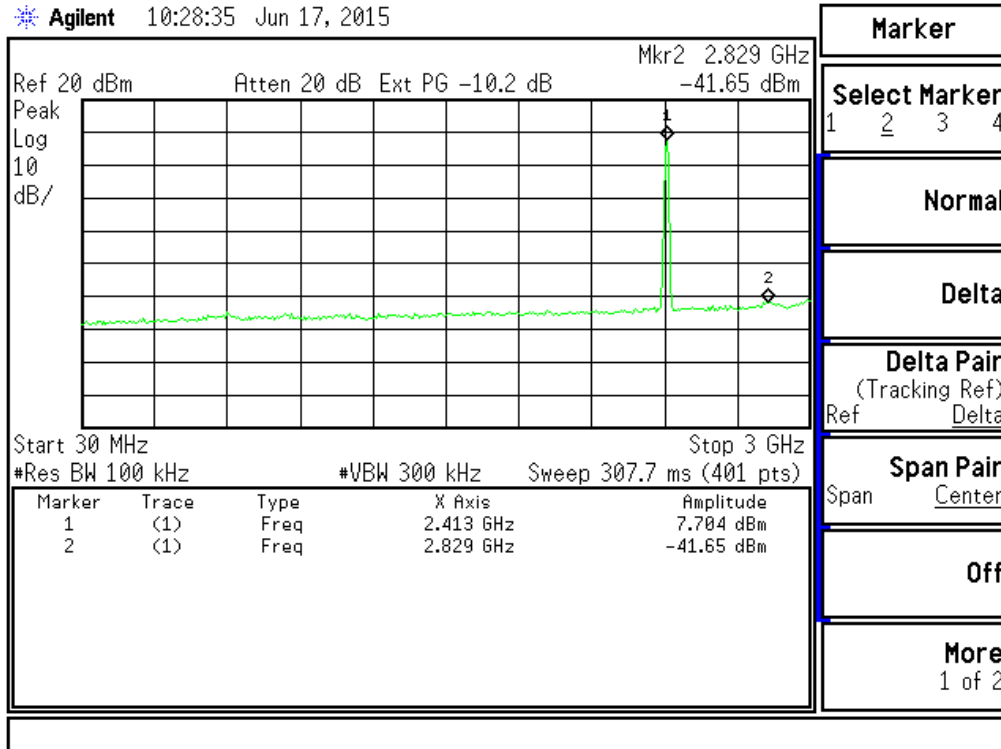

Note: Ext PG = Attenuator + Cable loss.

802.11b (CH01) (2 of 2)

Agilent 10:30:11 Jun 17, 2015

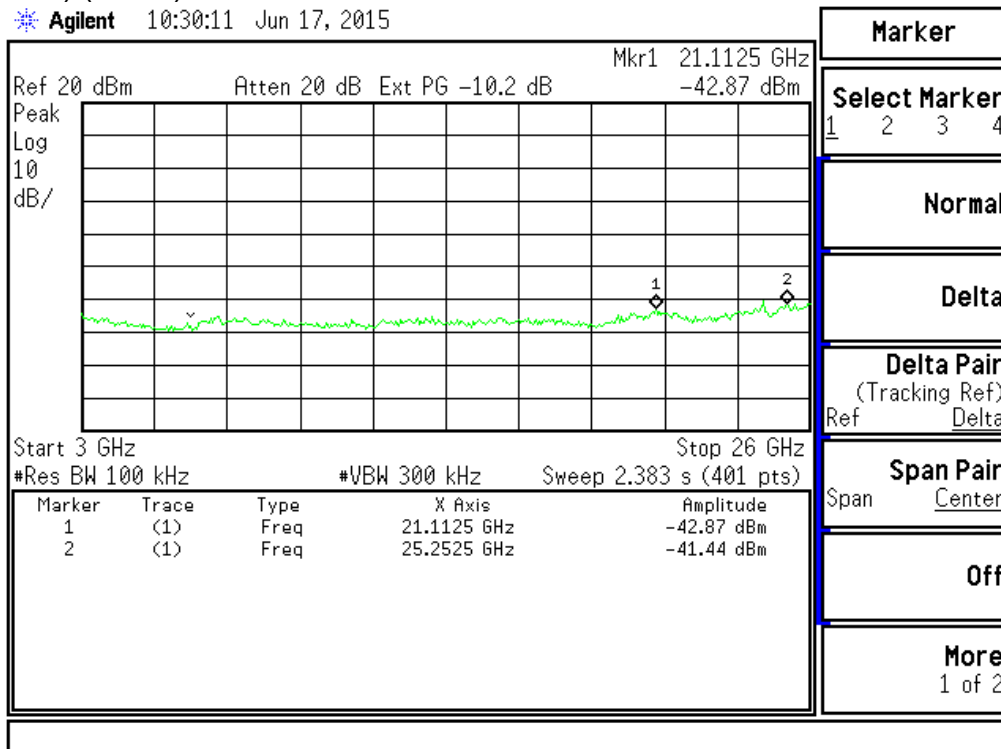

802.11b (CH06) (1 of 2)

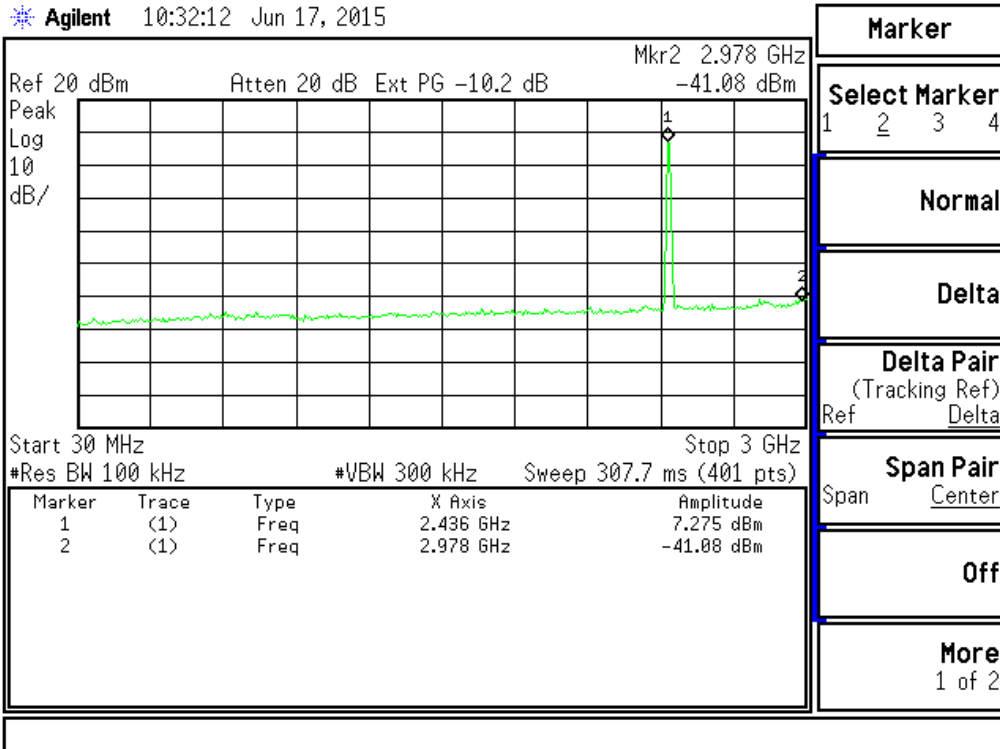

802.11b (CH06) (2 of 2)

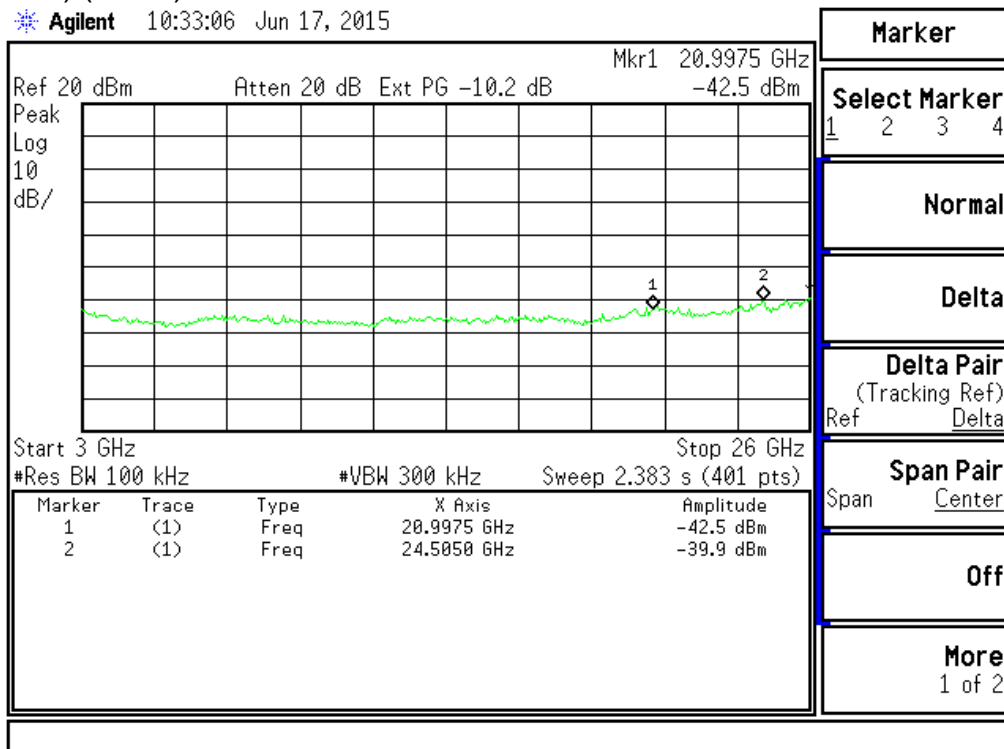

802.11b (CH11) (1 of 2)

Agilent 10:34:03 Jun 17, 2015

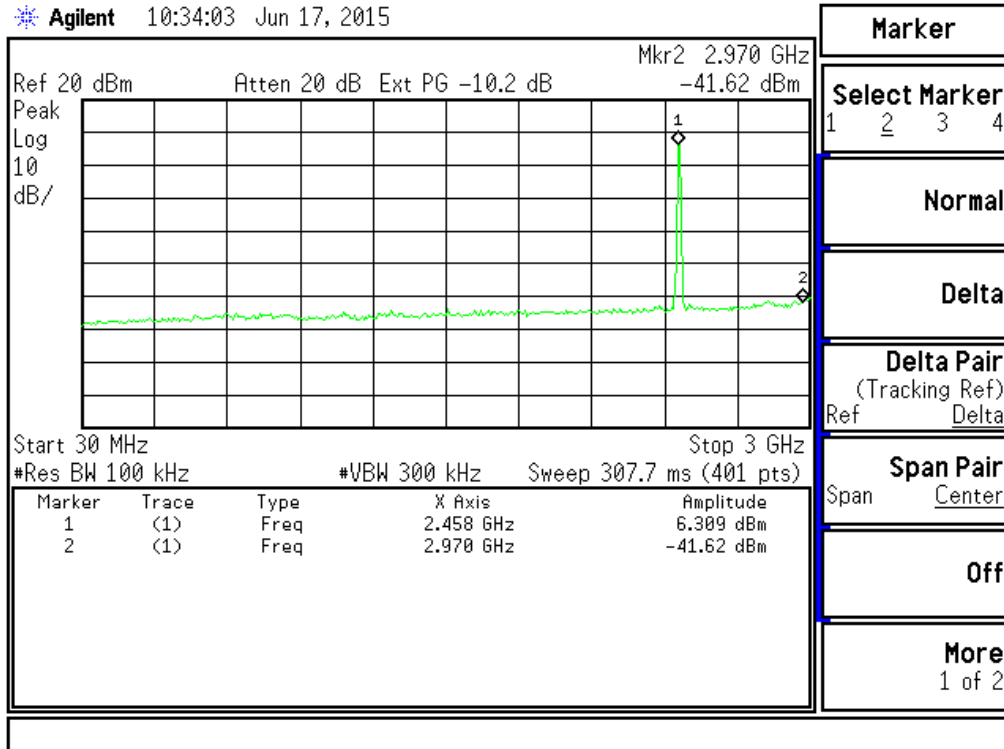

802.11b (CH11) (2 of 2)

Agilent 10:34:51 Jun 17, 2015

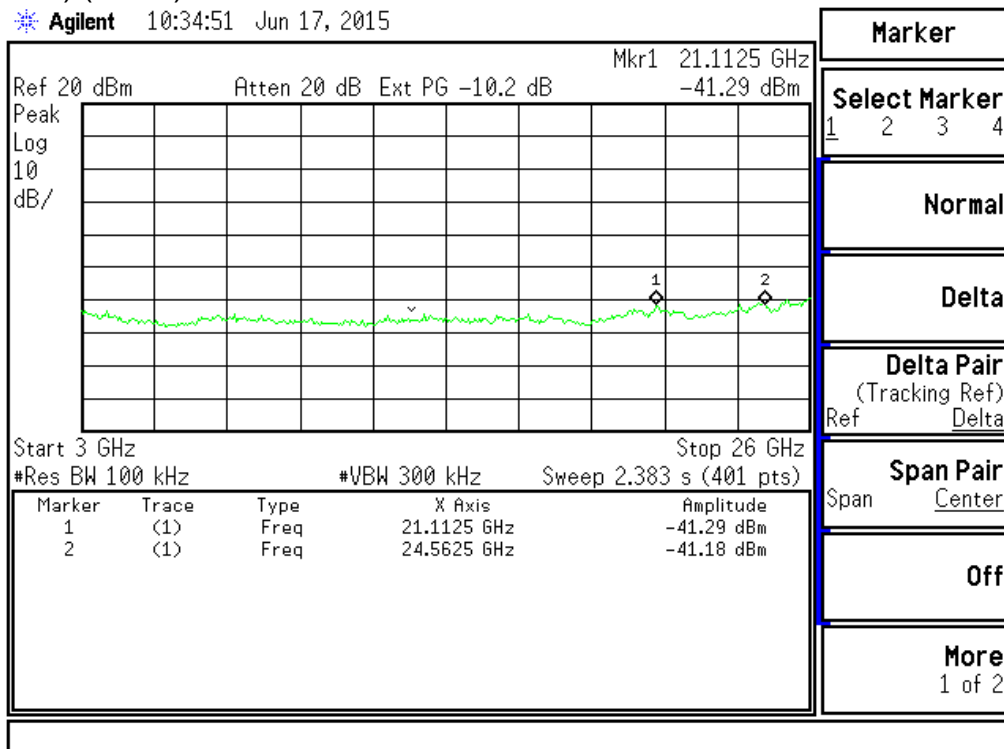

802.11g (CH01) (1 of 2)

Agilent 15:08:36 May 25, 2015

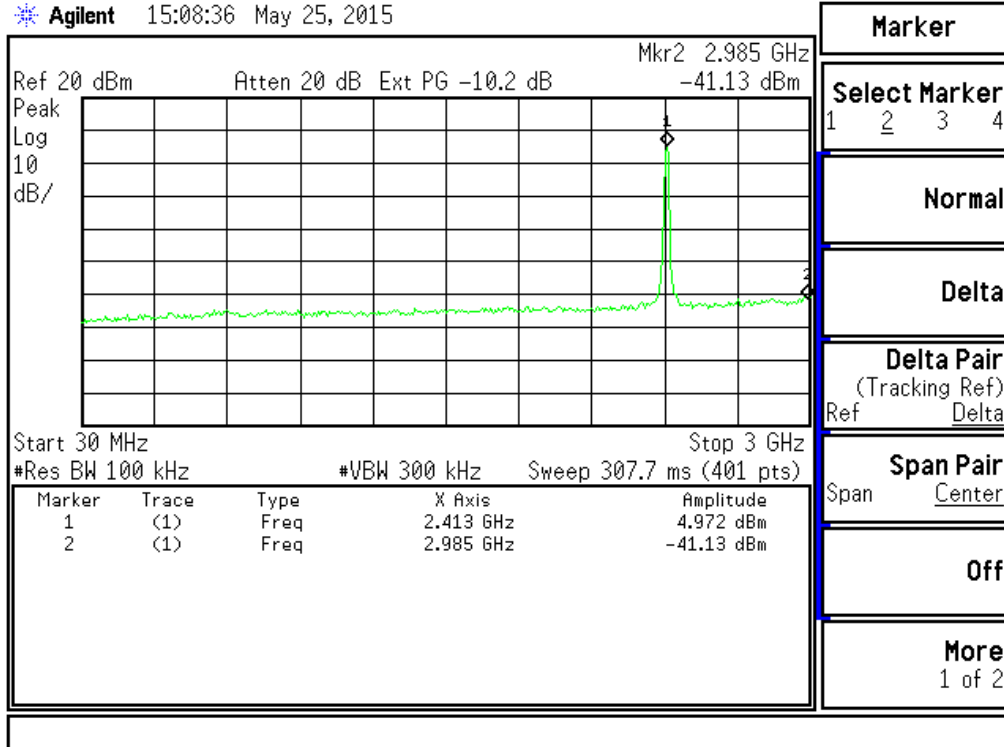

802.11g (CH01) (2 of 2)

Agilent 15:09:30 May 25, 2015

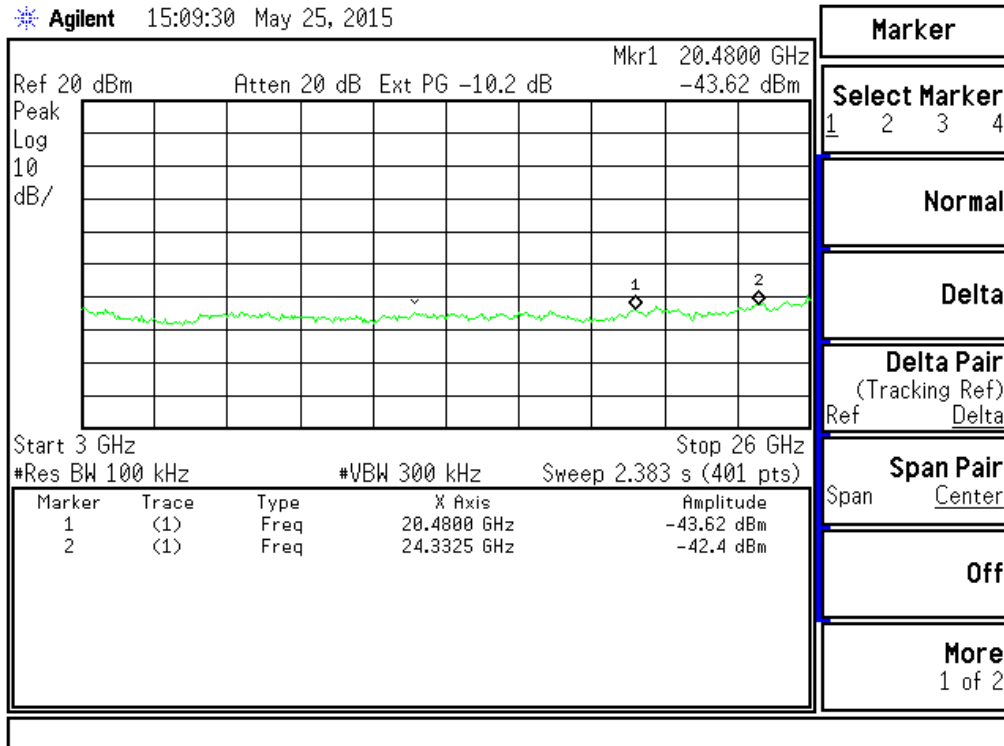

802.11g (CH06) (1 of 2)

Agilent 15:10:12 May 25, 2015

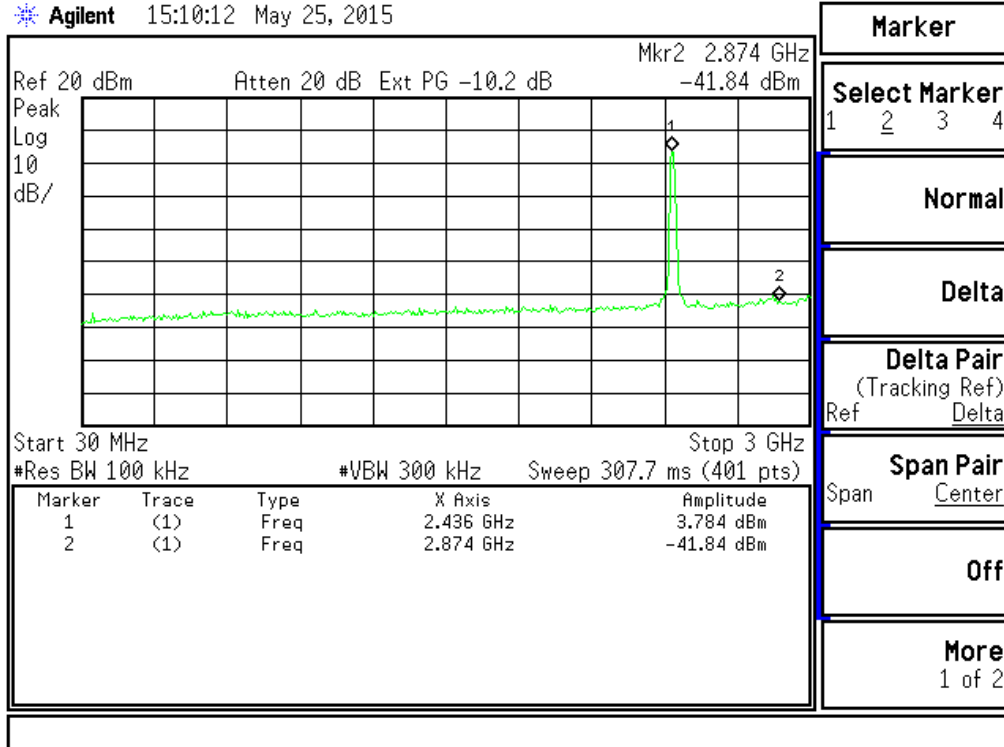

802.11g (CH06) (2 of 2)

Agilent 15:11:26 May 25, 2015

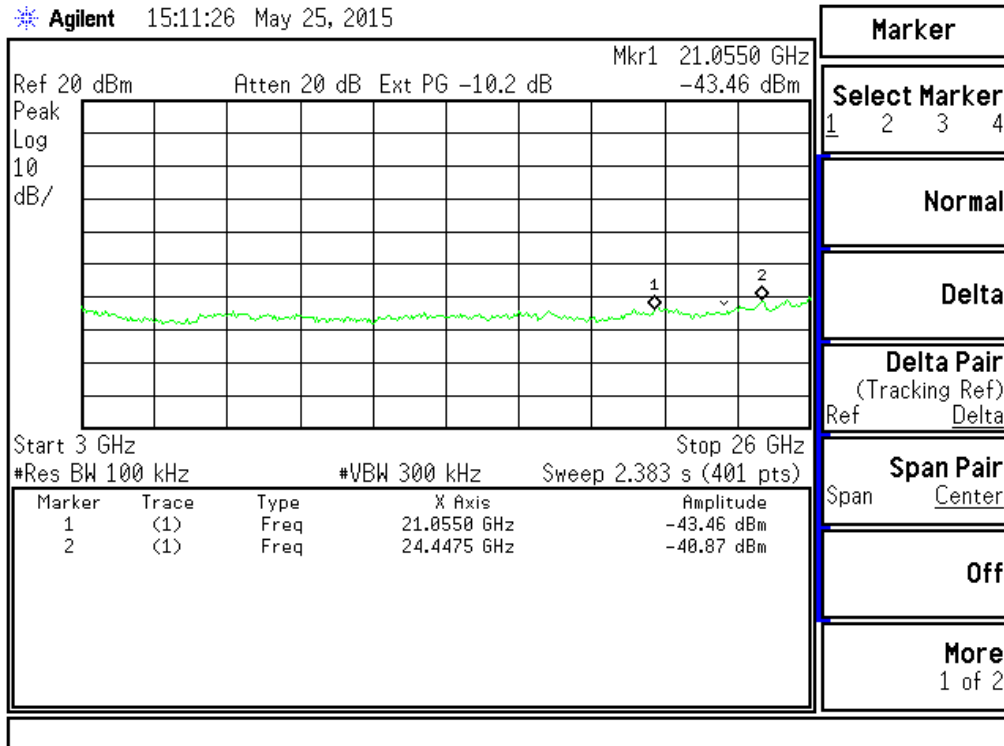

802.11g (CH11) (1 of 2)

Agilent 15:12:18 May 25, 2015

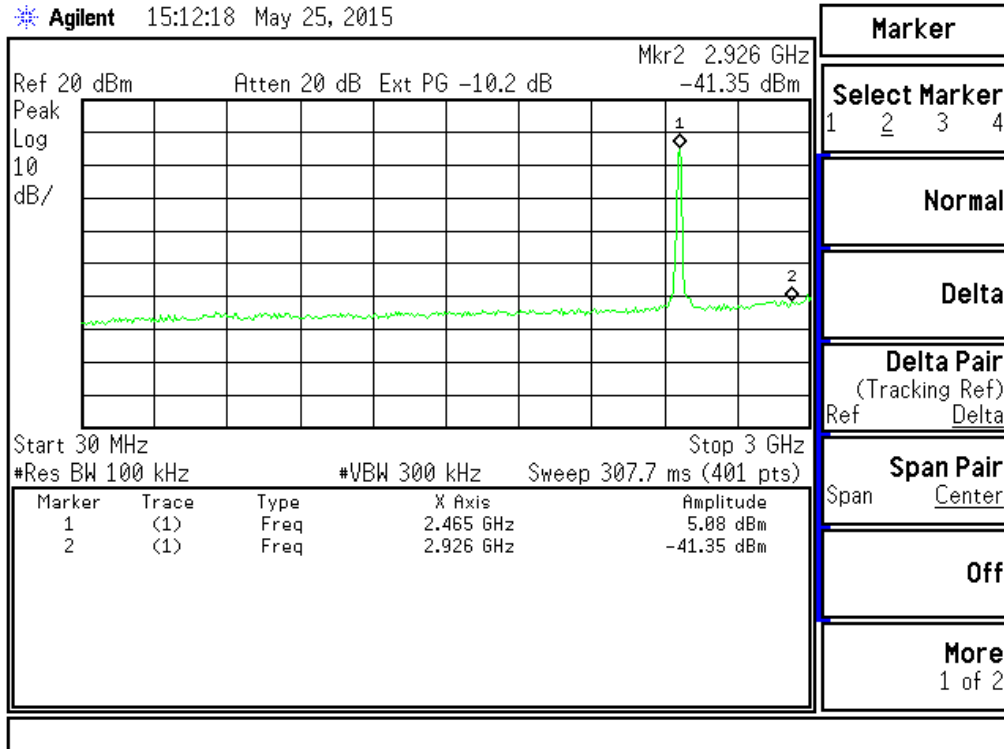

802.11g (CH11) (2 of 2)

Agilent 15:13:01 May 25, 2015

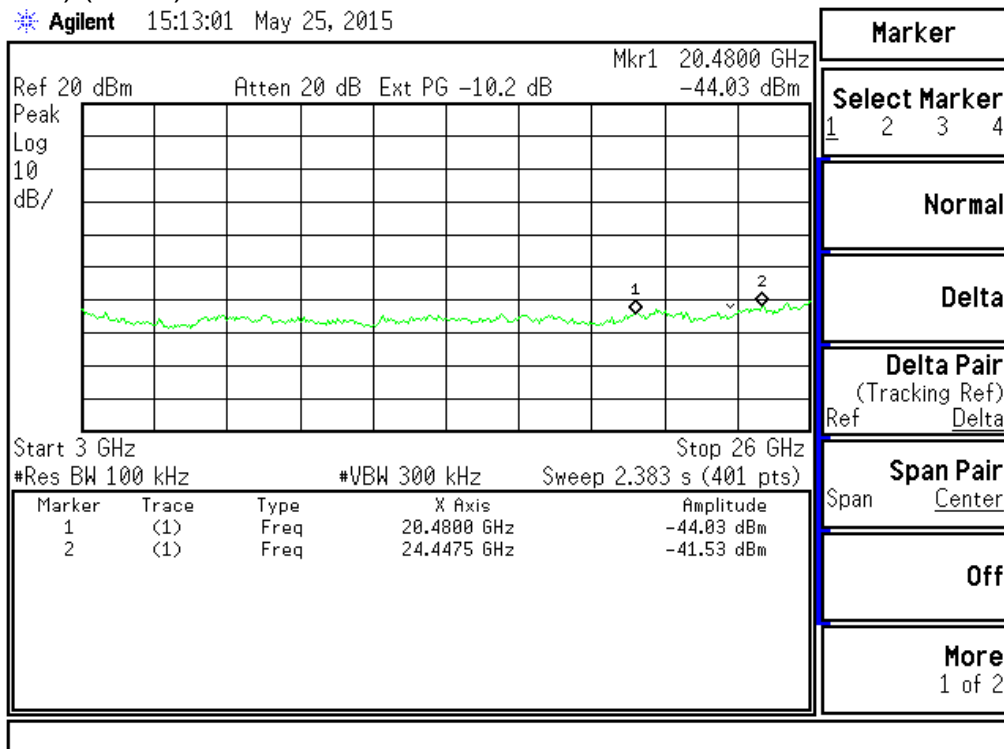

802.11n HT20 (Ant 1)(CH01) (1 of 2)

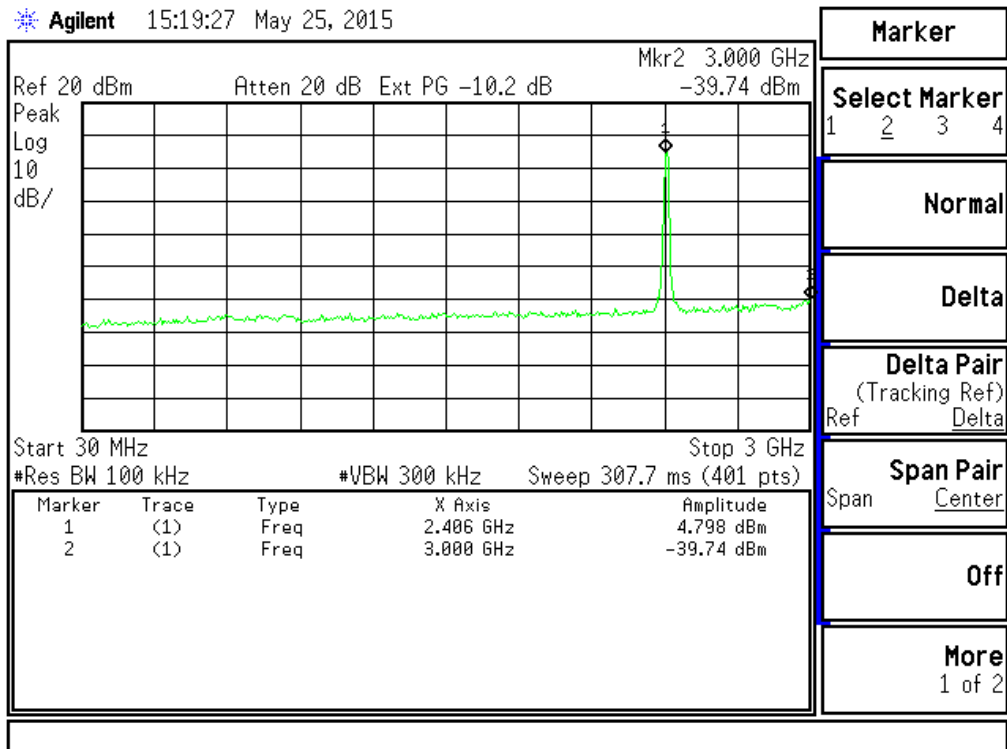

802.11n HT20 (Ant 1)(CH01) (2 of 2)

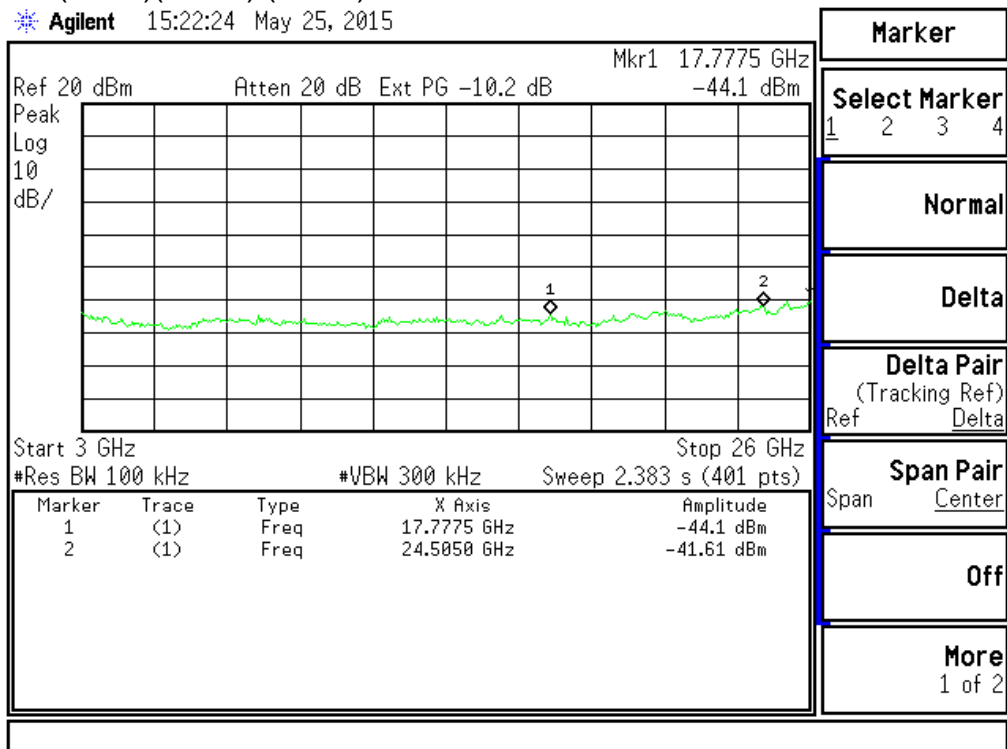

802.11n HT20 (Ant 1)(CH06) (1 of 2)

Agilent 15:25:00 May 25, 2015

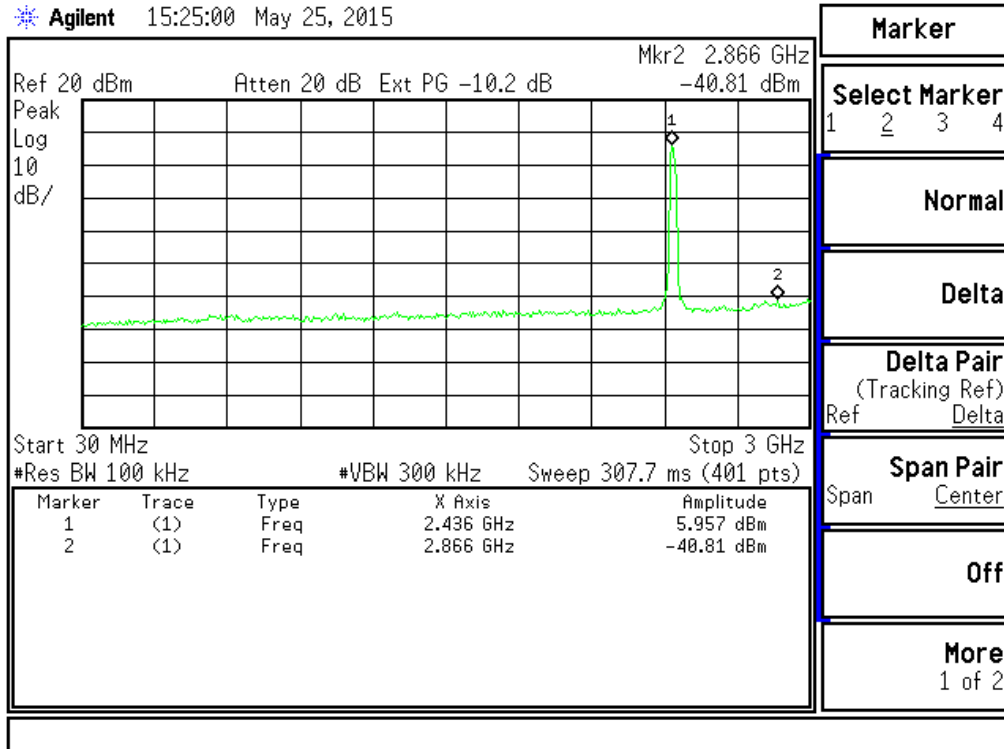

802.11n HT20 (Ant 1)(CH06) (2 of 2)

Agilent 15:25:52 May 25, 2015

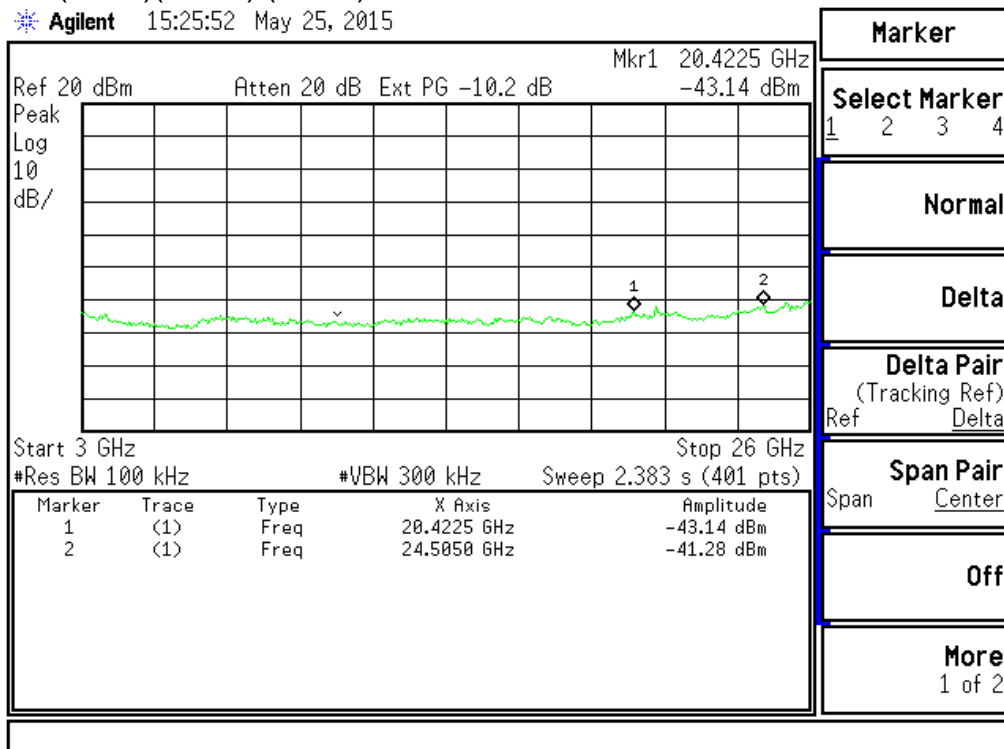

802.11n HT20 (Ant 1)(CH11) (1 of 2)

Agilent 15:28:14 May 25, 2015

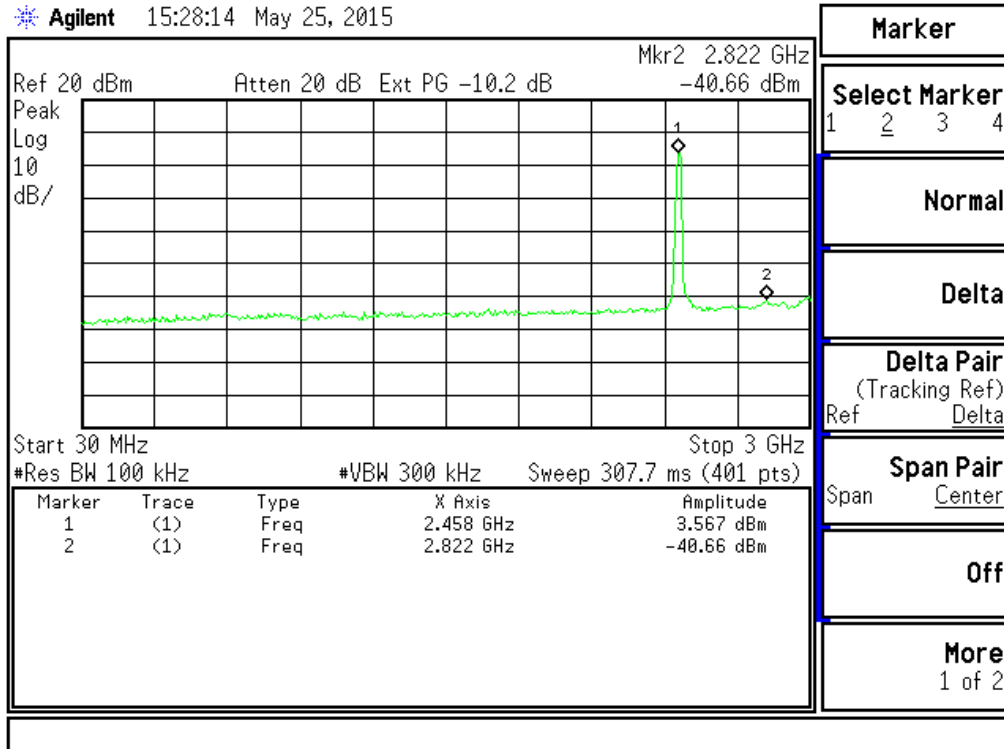

802.11n HT20 (Ant 1)(CH11) (2 of 2)

Agilent 15:28:59 May 25, 2015

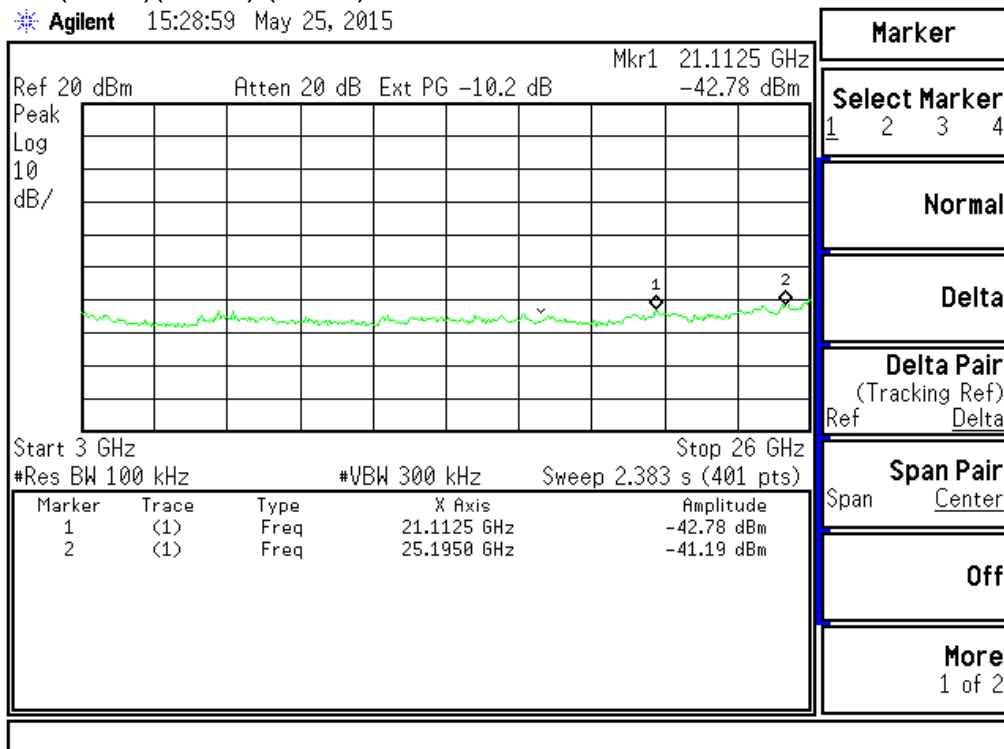

802.11n HT40 (Ant 1)(CH03) (1 of 2)

Agilent 15:33:05 May 25, 2015

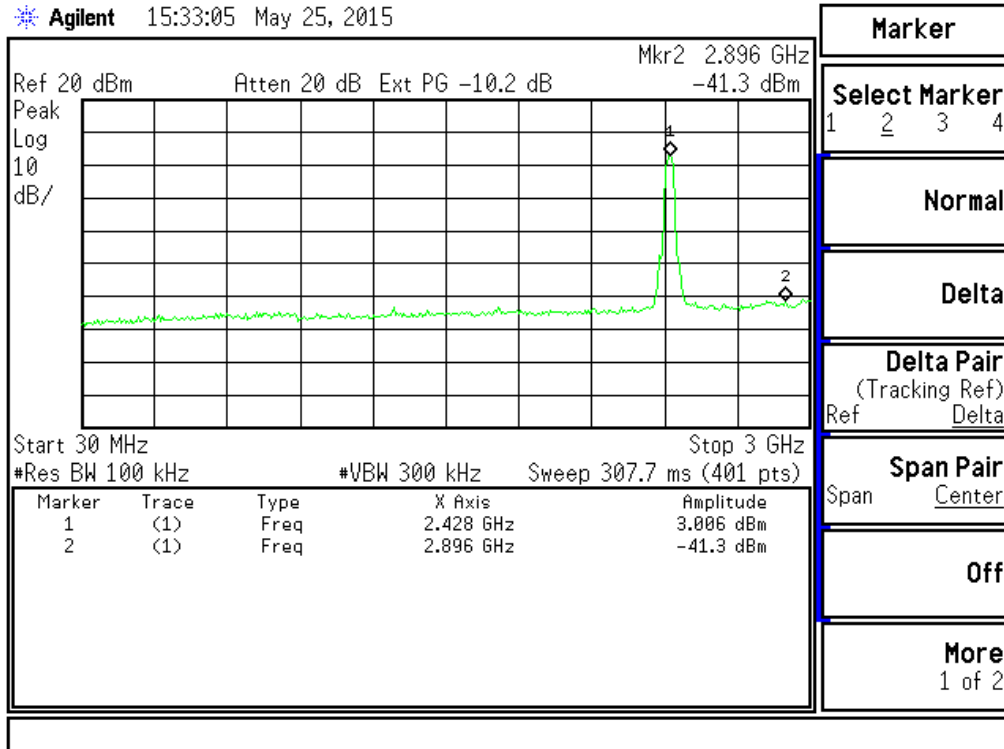

802.11n HT40 (Ant 1)(CH03) (2 of 2)

Agilent 15:33:48 May 25, 2015

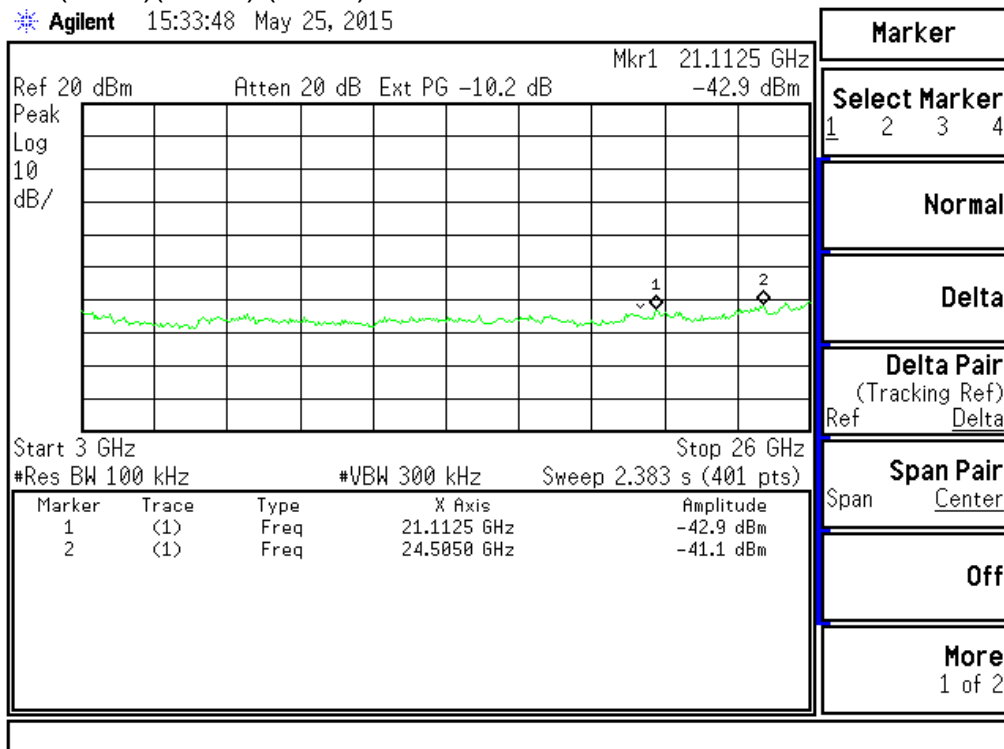

802.11n HT40 (Ant 1)(CH06) (1 of 2)

Agilent 15:49:21 May 25, 2015

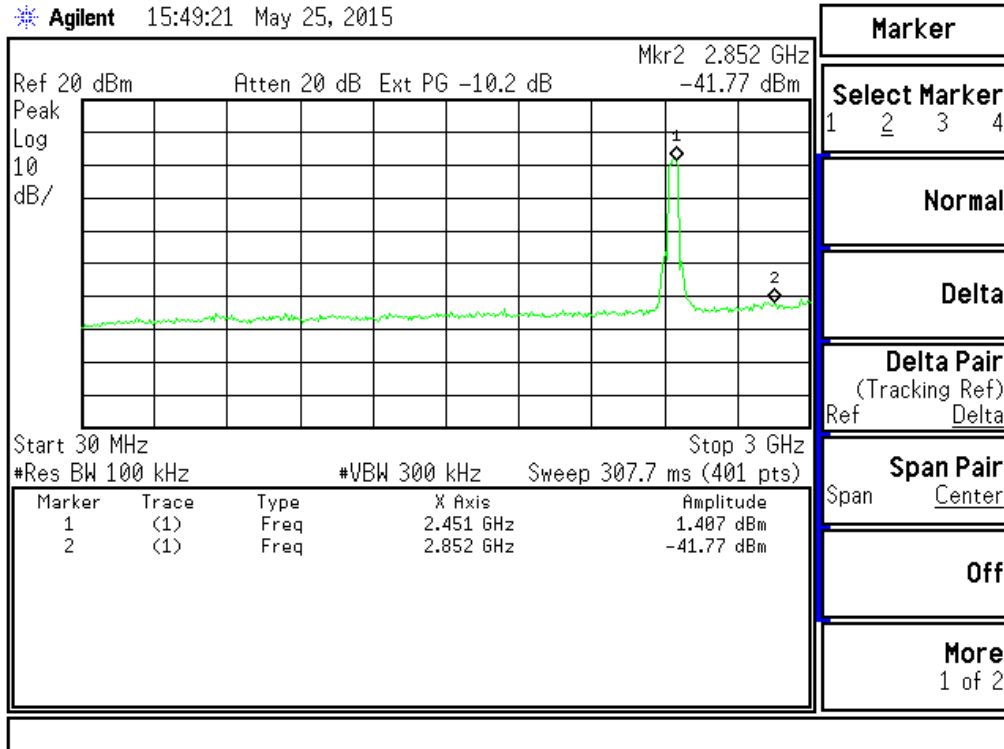

802.11n HT40 (Ant 1)(CH06) (2 of 2)

Agilent 15:49:59 May 25, 2015

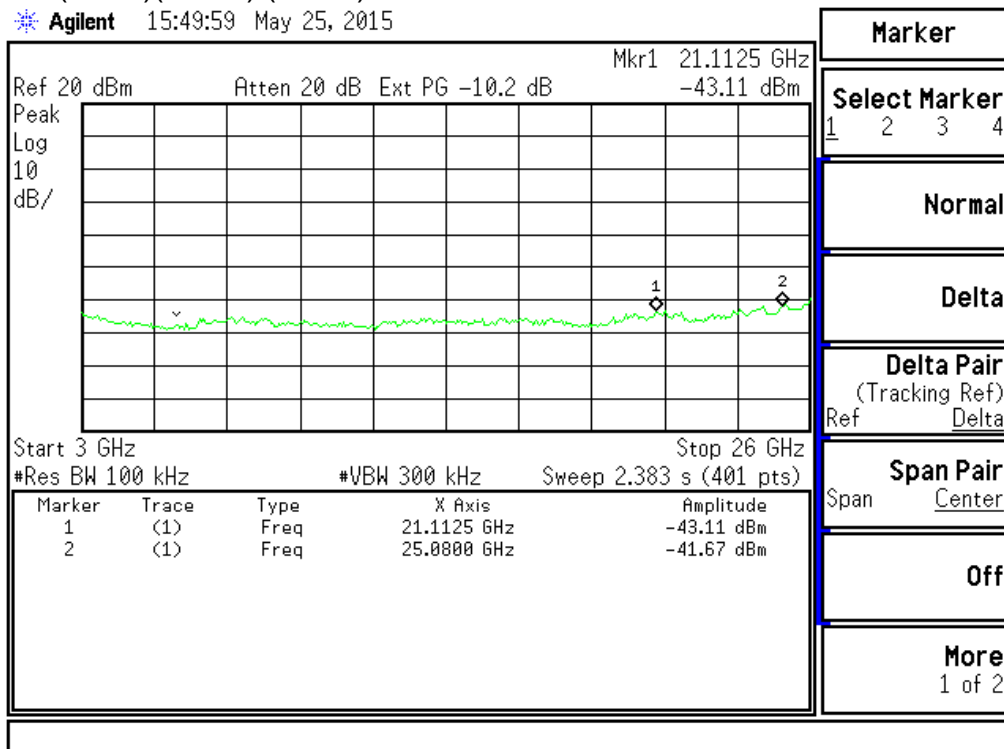

802.11n HT40 (Ant 1)(CH09) (1 of 2)

Agilent 15:52:25 May 25, 2015

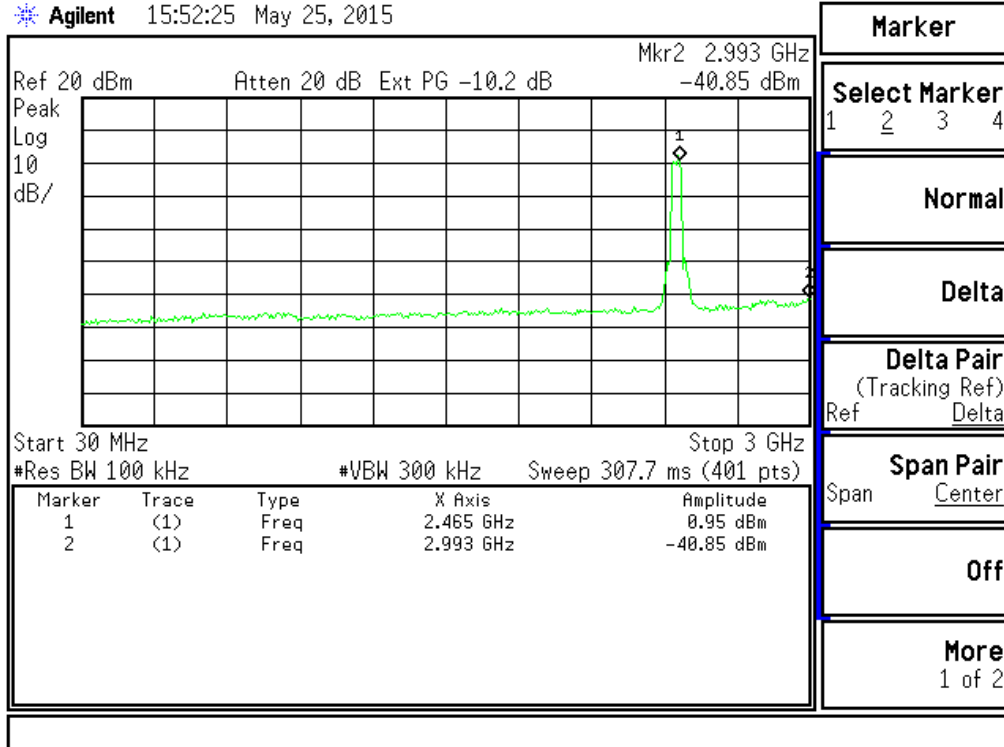

802.11n HT40 (Ant 1)(CH09) (2 of 2)

Agilent 15:53:06 May 25, 2015

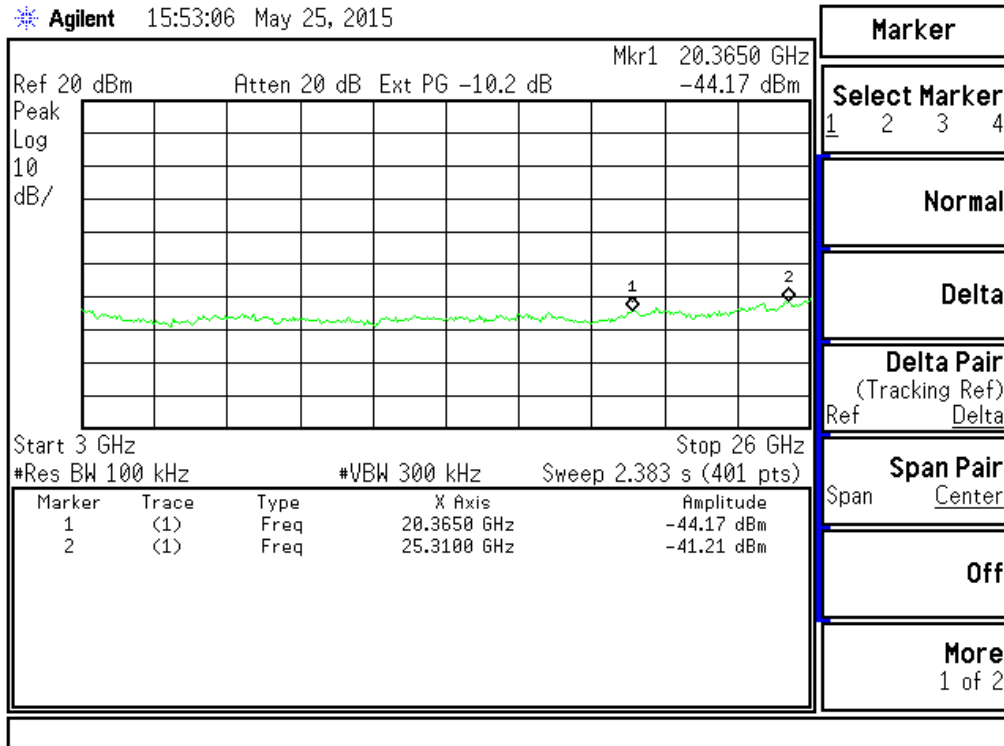

802.11n HT20 (Ant 2)(CH01) (1 of 2)

Agilent 15:23:08 May 25, 2015

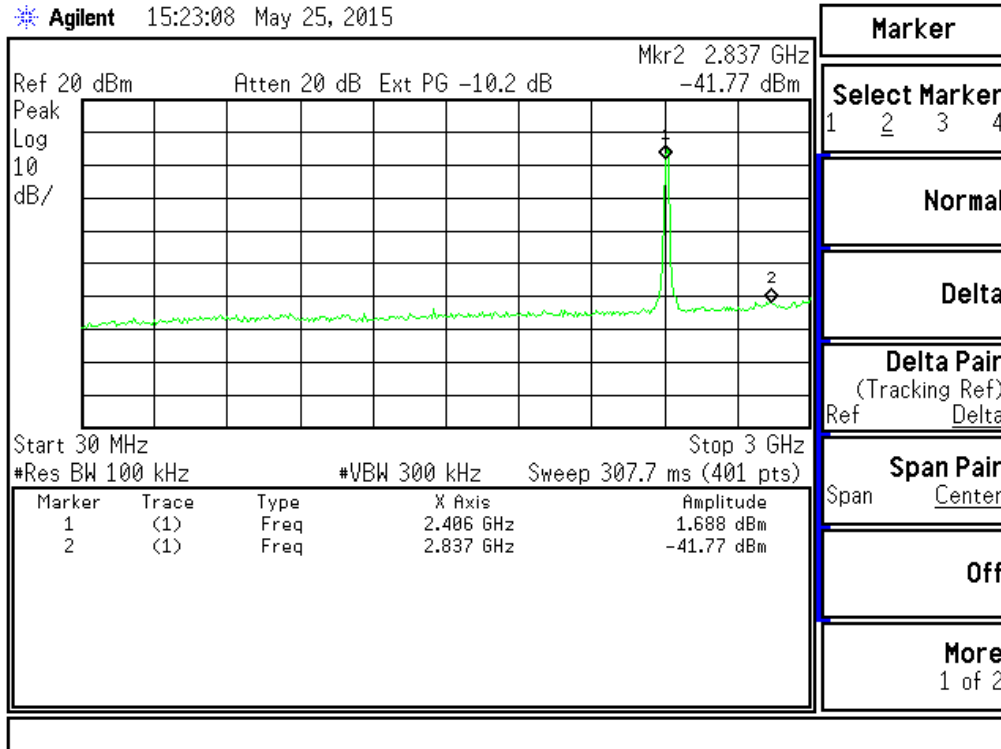

802.11n HT20 (Ant 2)(CH01) (2 of 2)

Agilent 15:23:47 May 25, 2015

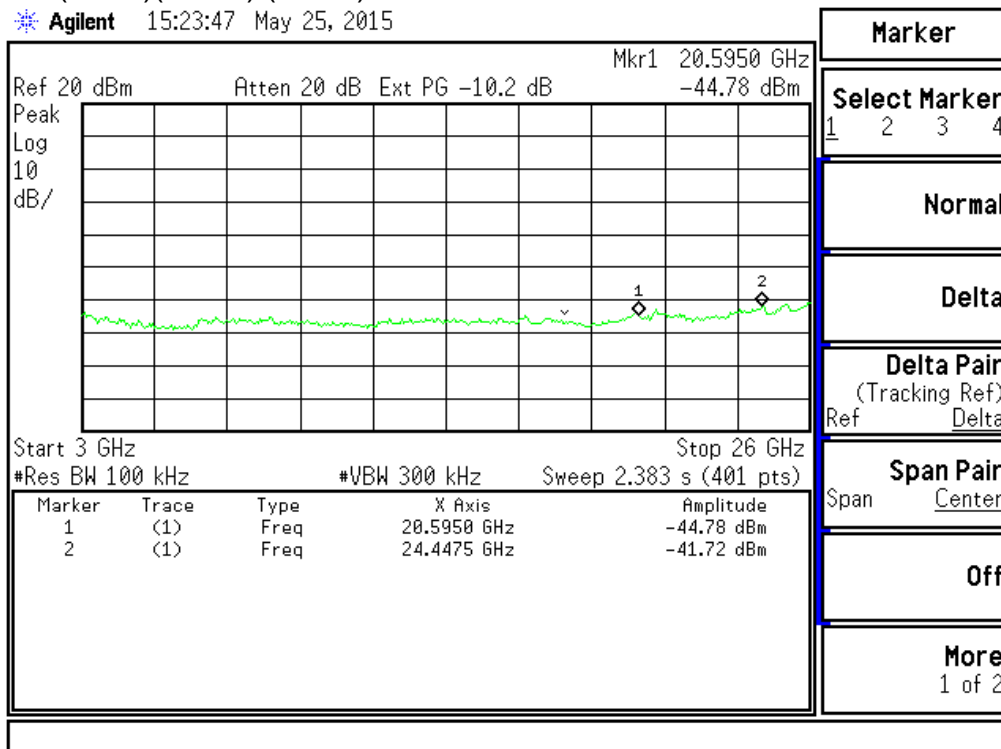

802.11n HT20 (Ant 2)(CH06) (1 of 2)

Agilent 15:26:37 May 25, 2015

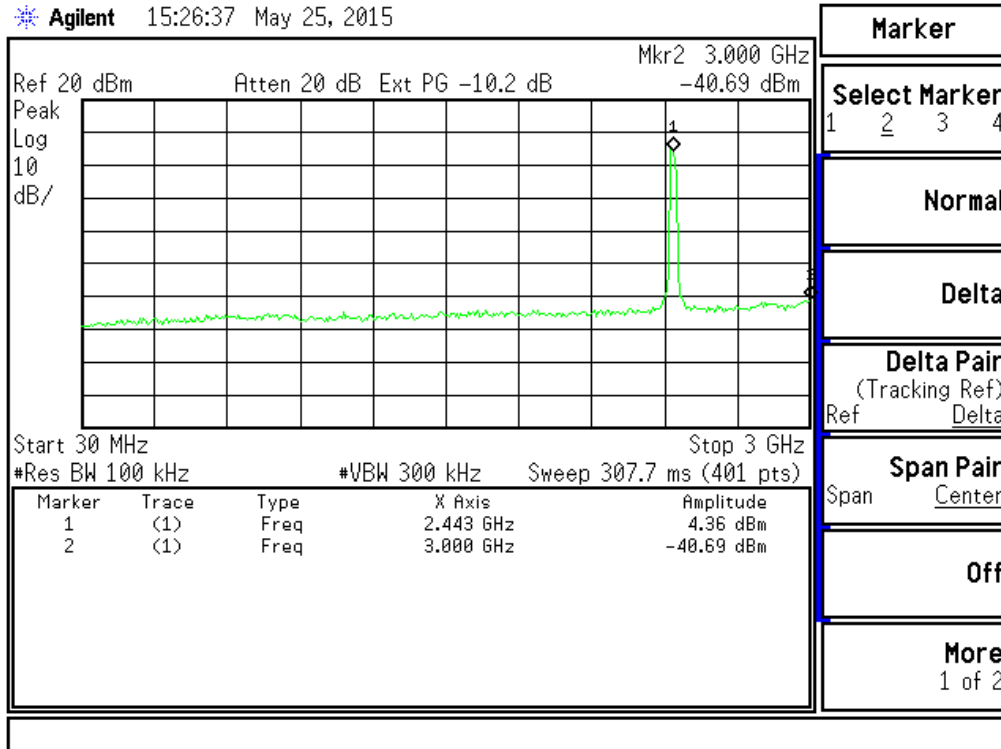

802.11n HT20 (Ant 2)(CH06) (2 of 2)

Agilent 15:27:23 May 25, 2015

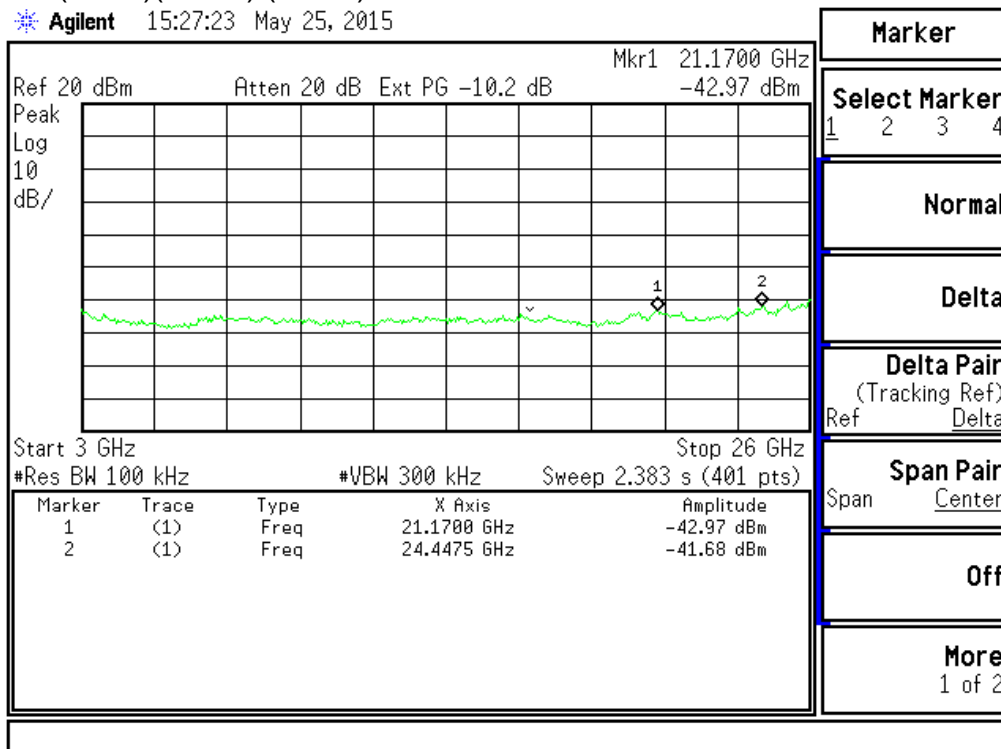

802.11n HT20 (Ant 2)(CH11) (1 of 2)

Agilent 15:31:25 May 25, 2015

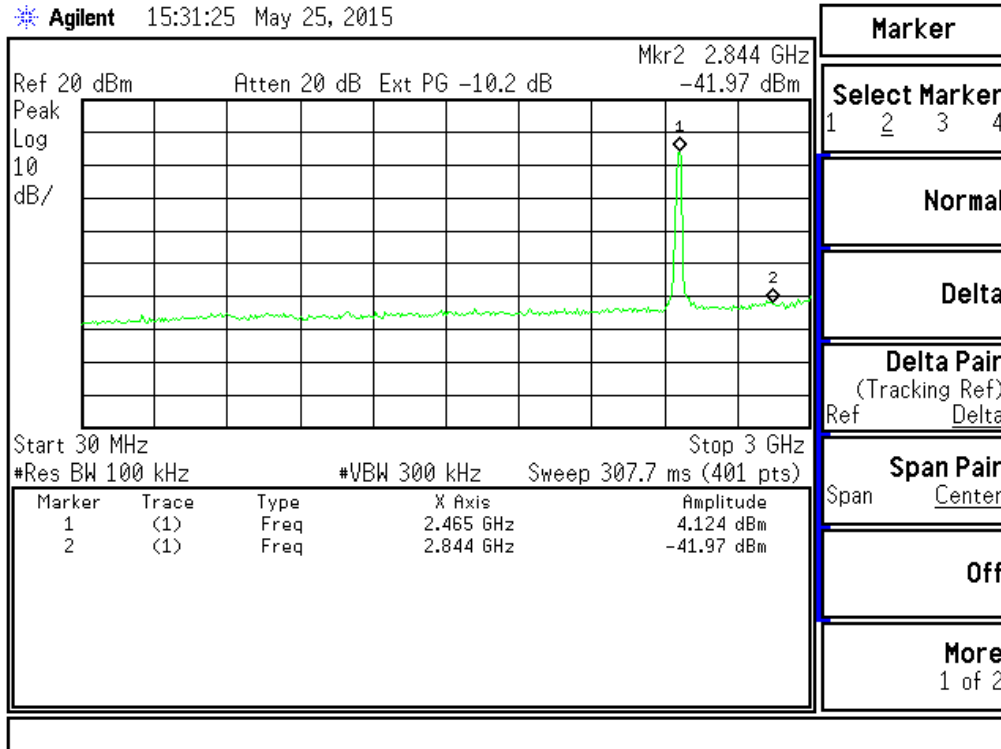

802.11n HT20 (Ant 2)(CH11) (2 of 2)

Agilent 15:32:06 May 25, 2015

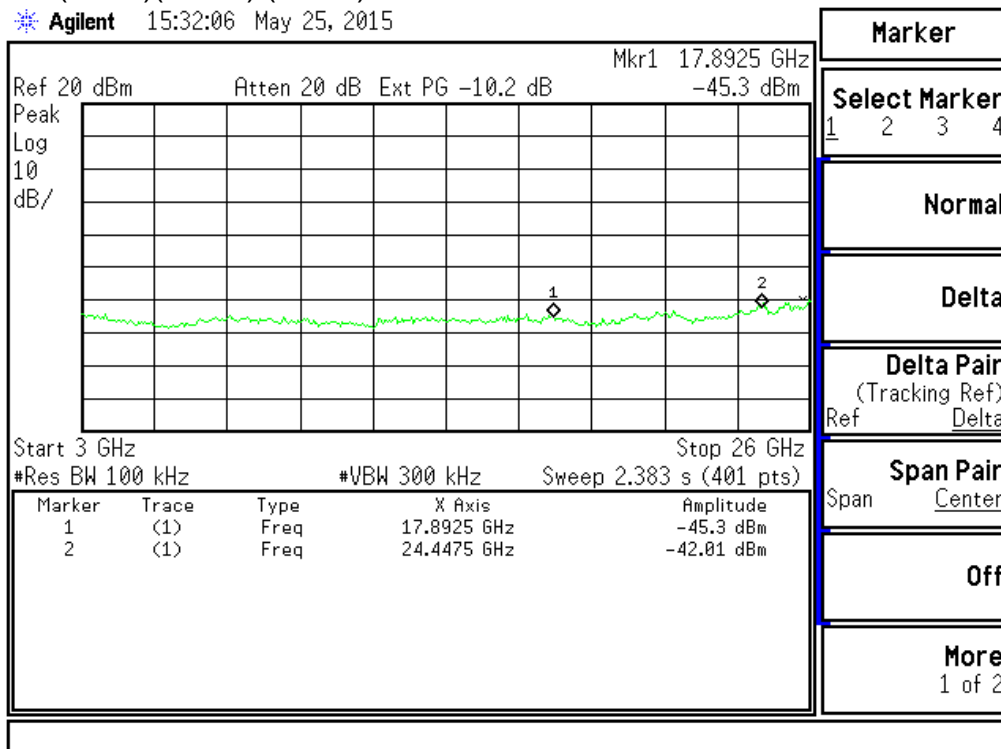

802.11n HT40 (Ant 2)(CH03) (1 of 2)

Agilent 15:47:40 May 25, 2015

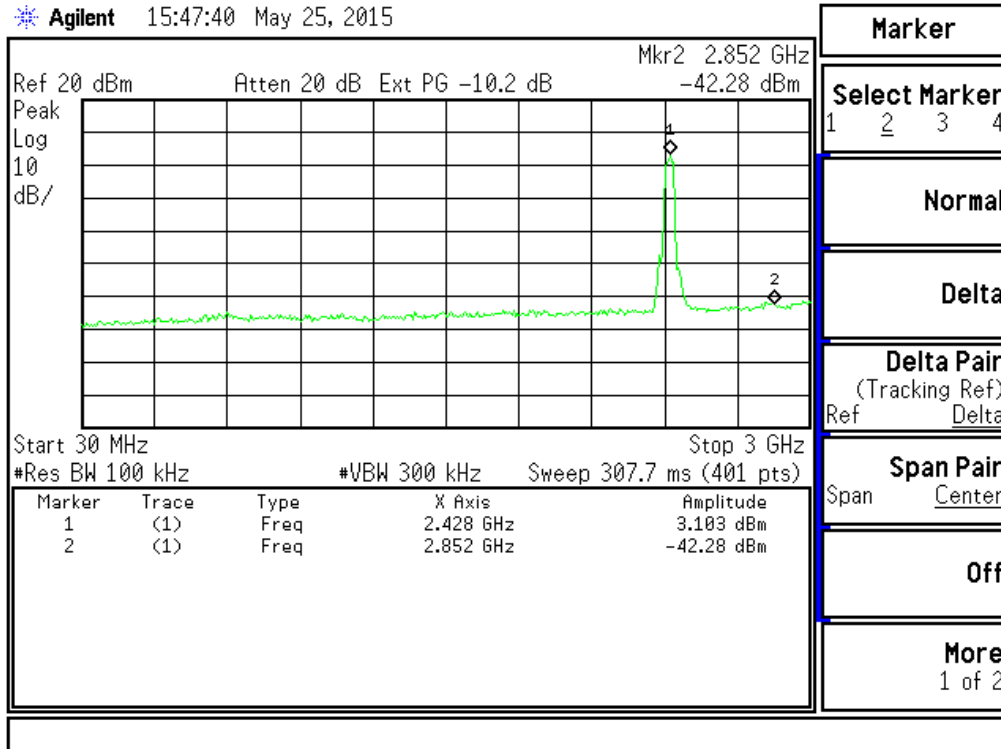

802.11n HT40 (Ant 2)(CH03) (2 of 2)

Agilent 15:48:33 May 25, 2015

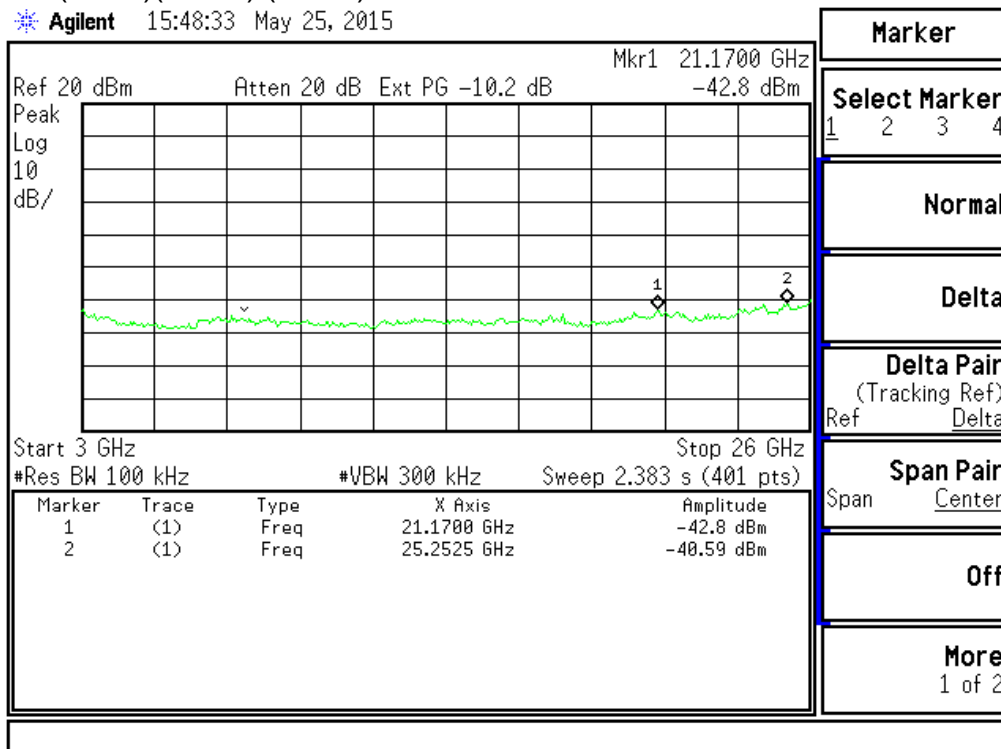

802.11n HT40 (Ant 2)(CH06) (1 of 2)

Agilent 15:50:53 May 25, 2015

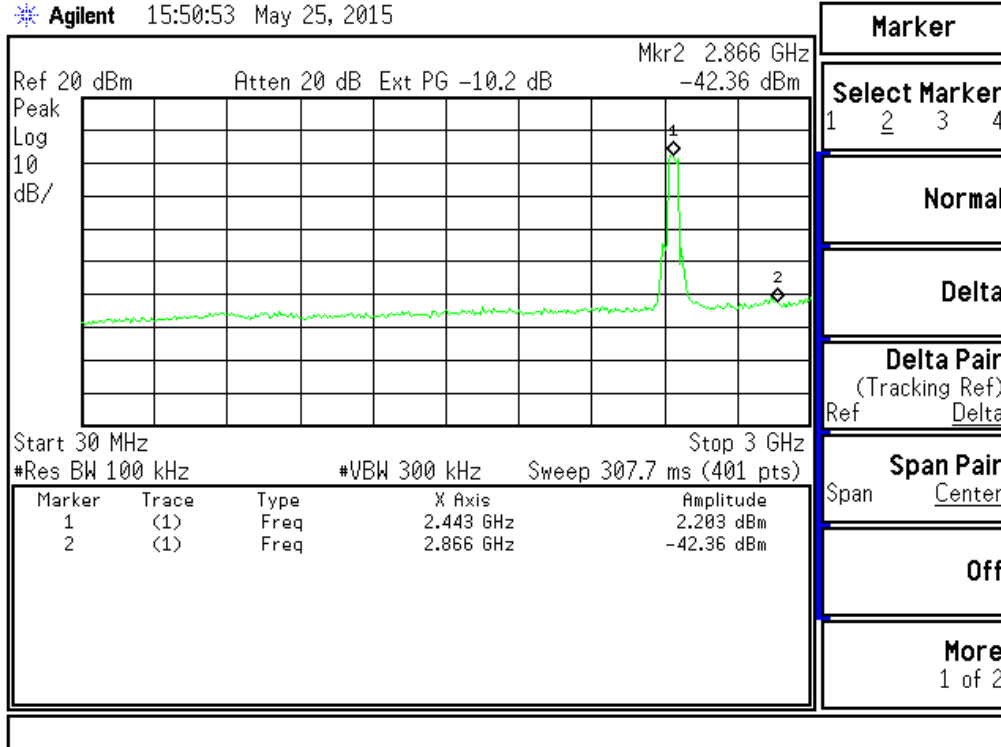

802.11n HT40 (Ant 2)(CH06) (2 of 2)

Agilent 15:51:39 May 25, 2015

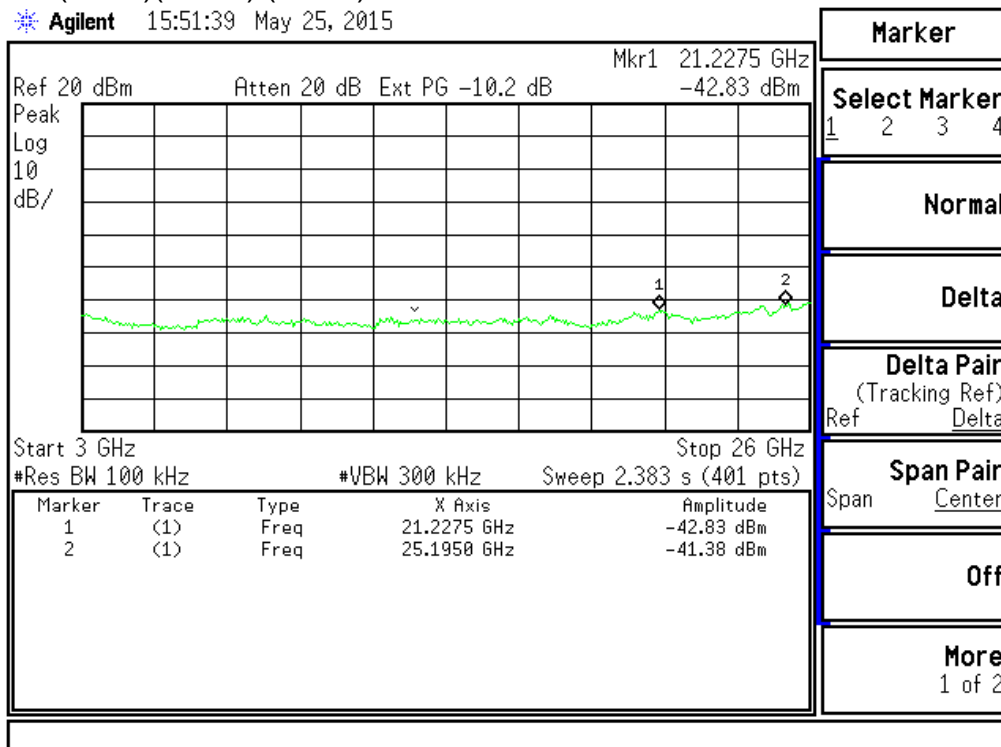

802.11n HT40 (Ant 2)(CH09) (1 of 2)

Agilent 15:53:50 May 25, 2015

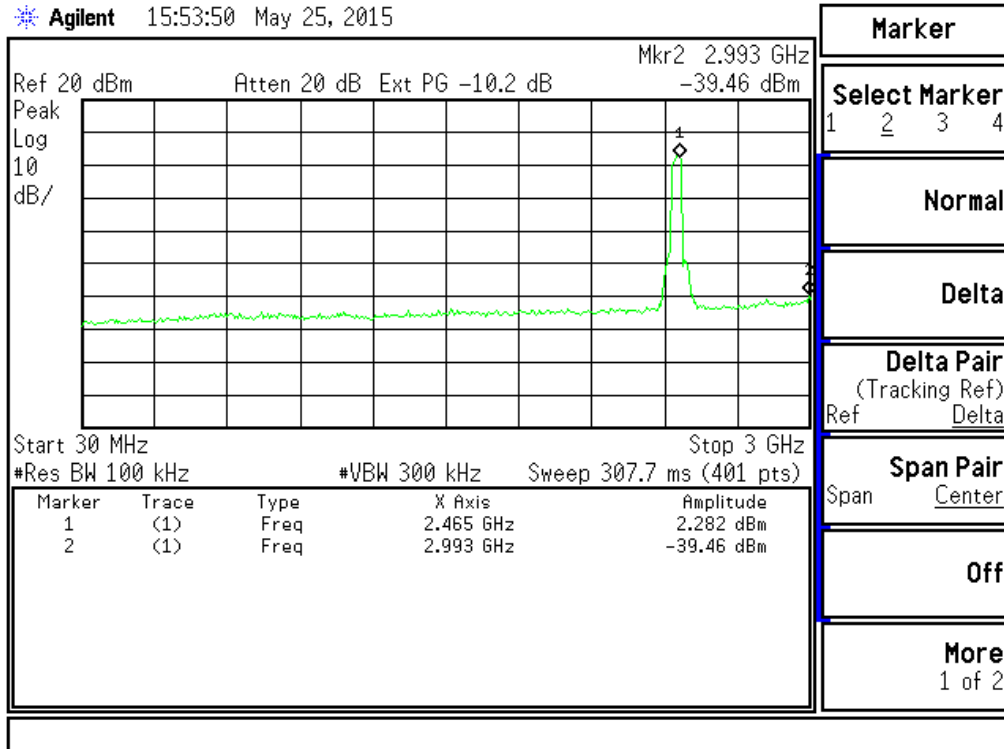

802.11n HT40 (Ant 2)(CH09) (2 of 2)

Agilent 15:55:47 May 25, 2015

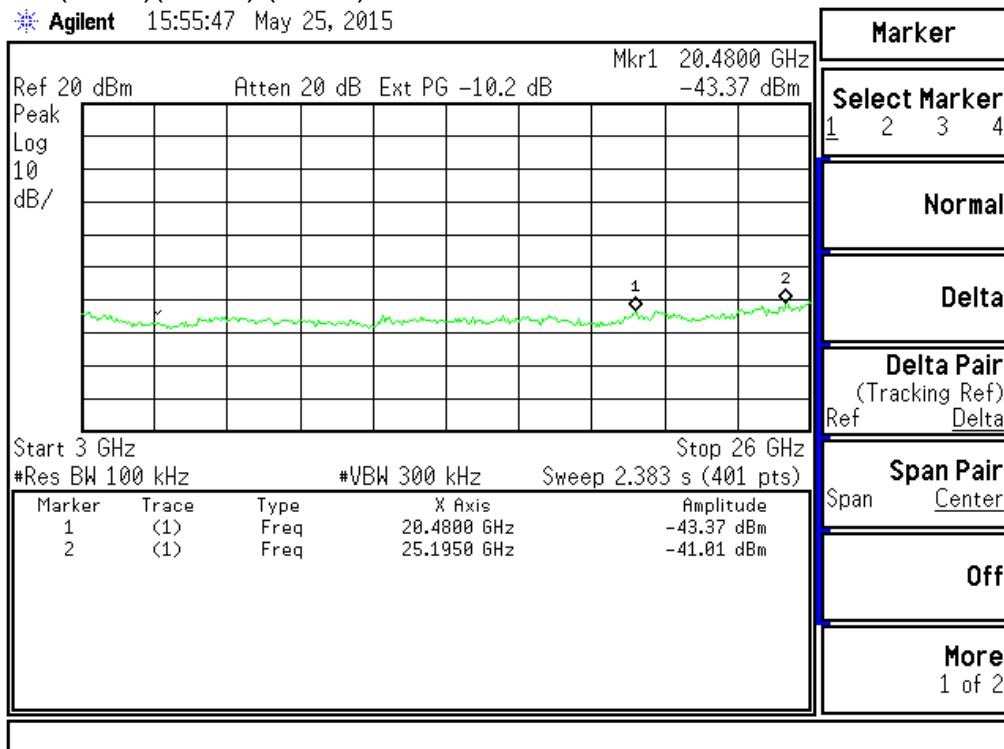

8. Band Edges Requirement

8.1 Test Condition & Setup :

According to 15.247(d), In any 100 kHz bandwidth outside the frequency band in which the spread spectrum or digitally modulated intentional radiator is operating, the radio frequency power that is produced by the intentional radiator shall be at least 20 dB below that in the 100 kHz bandwidth within the band that contains the highest level of the desired power, based on either an RF con-ducted or a radiated measurement, provided the transmitter demonstrates compliance with the peak conducted power limits.

The marker-delta method, as described in ANSI C63.10, can be used to perform measurements of the radiated unwanted emissions level at the band-edges provided that the 99% OBW of the fundamental emission is within 2 MHz of the authorized band edge.

Measurement procedure is followed KDB 558074 v03r04 (13.2 Marker-delta method)

8.2 Test Instruments Configuration:

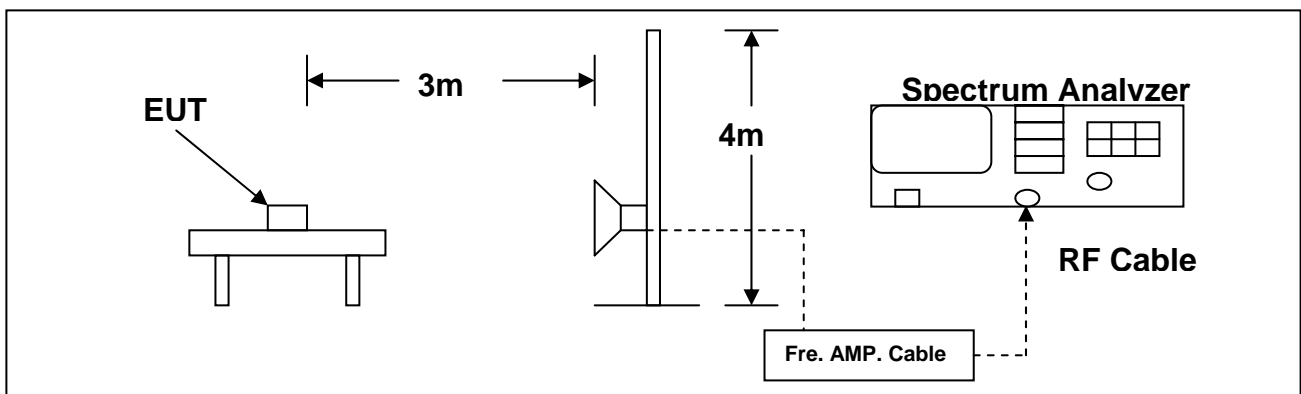

8.3 Test Equipment List:

Item	Mfr/Brand	Instruments	Serial No.	Model/Type No.	Calibrated Date	Next Cal. Date
1.	Agilent	Spectrum Analyzer	US44300422	E4446A	2015/02/04	2016/02/04
2.	MLT	Pre Amplifier	0.10~19.1GHz 60dBm	RF01	2015/11/17	2016/11/17
3.	MLT	Pre Amplifier	TA010-190-30	RF03	2015/08/10	2016/08/10
4.	MLT	Pre Amplifier	20110209	PREAMP6G-01	2015/03/17	2016/03/17
5.	SCHWARZBECK	Horn Antenna	181	BBHA 9170	2015/11/24	2016/11/24
6.	SCHWARZBECK	Horn Antenna	304	BBHA 9120D	2015/11/24	2016/11/24

8.4 Test Result : Worst case

(802.11b)

Radiated Emissions (HORIZONTAL) CH01						
Frequency (MHz)	Amplitude (dBuV/m)	Ant. (m)	Table (Degree)	Duty (dB)	Limit (dBuV/m)	Margin (dB)
2399.8	53.3 (PK)	1	190	0	74.0(PK)	-20.7
2399.8	39.9 (AV)	1	190	0	54.0(AV)	-14.1

Radiated Emissions (VERTICAL) CH01						
Frequency (MHz)	Amplitude (dBuV/m)	Ant. (m)	Table (Degree)	Duty (dB)	Limit (dBuV/m)	Margin (dB)
2399.8	65.7 (PK)	1	176	0	74.0(PK)	-8.3
2399.8	49.3 (AV)	1	176	0	54.0(AV)	-4.7

Radiated Emissions (HORIZONTAL) CH11						
Frequency (MHz)	Amplitude (dBuV/m)	Ant. (m)	Table (Degree)	Duty (dB)	Limit (dBuV/m)	Margin (dB)
2484.3	47.1 (PK)	1	190	0	74.0(PK)	-26.9
2484.3	34.2 (AV)	1	190	0	54.0(AV)	-19.8

Radiated Emissions (VERTICAL) CH11						
Frequency (MHz)	Amplitude (dBuV/m)	Ant. (m)	Table (Degree)	Duty (dB)	Limit (dBuV/m)	Margin (dB)
2485.4	51.3 (PK)	1	53	0	74.0(PK)	-22.8
2485.4	37.1 (AV)	1	53	0	54.0(AV)	-16.9

- Notes :**
1. Margin= Amplitude - Limits
 2. Height of table for EUT placed: 1.5 Meter.
 3. ANT= Antenna height.
 4. Duty= Duty cycle correction factor.
 5. Amplitude= Reading Amplitude – Amplifier gain+ Cable loss+ Antenna factor
(Auto calculate in spectrum analyzer)

(802.11g)

Radiated Emissions (HORIZONTAL) CH01						
Frequency (MHz)	Amplitude (dBuV/m)	Ant. (m)	Table (Degree)	Duty (dB)	Limit (dBuV/m)	Margin (dB)
2398.2	61.5 (PK)	1	195	0	74.0(PK)	-12.5
2398.2	35.8 (AV)	1	195	0	54.0(AV)	-18.2

Radiated Emissions (VERTICAL) CH01						
Frequency (MHz)	Amplitude (dBuV/m)	Ant. (m)	Table (Degree)	Duty (dB)	Limit (dBuV/m)	Margin (dB)
2399.0	72.3 (PK)	1	160	0	74.0(PK)	-1.7
2399.0	41.3 (AV)	1	160	0	54.0(AV)	-12.7

Radiated Emissions (HORIZONTAL) CH11						
Frequency (MHz)	Amplitude (dBuV/m)	Ant. (m)	Table (Degree)	Duty (dB)	Limit (dBuV/m)	Margin (dB)
2483.7	55.5 (PK)	1	322	0	74.0(PK)	-18.5
2483.7	35.8 (AV)	1	322	0	54.0(AV)	-18.3

Radiated Emissions (VERTICAL) CH11						
Frequency (MHz)	Amplitude (dBuV/m)	Ant. (m)	Table (Degree)	Duty (dB)	Limit (dBuV/m)	Margin (dB)
2484.0	64.9 (PK)	1	282	0	74.0(PK)	-9.1
2484.0	39.7 (AV)	1	282	0	54.0(AV)	-14.3

- Notes :**
1. Margin= Amplitude - Limits
 2. Height of table for EUT placed: 1.5 Meter.
 3. ANT= Antenna height.
 4. Duty= Duty cycle correction factor.
 5. Amplitude= Reading Amplitude – Amplifier gain+ Cable loss+ Antenna factor
(Auto calculate in spectrum analyzer)

(802.11n HT20)

Radiated Emissions (HORIZONTAL) CH01						
Frequency (MHz)	Amplitude (dBuV/m)	Ant. (m)	Table (Degree)	Duty (dB)	Limit (dBuV/m)	Margin (dB)
2398.8	62.5 (PK)	1	191	0	74.0(PK)	-11.5
2398.8	35.93 (AV)	1	191	0	54.0(AV)	-18.1

Radiated Emissions (VERTICAL) CH01						
Frequency (MHz)	Amplitude (dBuV/m)	Ant. (m)	Table (Degree)	Duty (dB)	Limit (dBuV/m)	Margin (dB)
2398.8	72.7 (PK)	1	76	0	74.0(PK)	-1.3
2398.8	39.5 (AV)	1	76	0	54.0(AV)	-14.6

Radiated Emissions (HORIZONTAL) CH11						
Frequency (MHz)	Amplitude (dBuV/m)	Ant. (m)	Table (Degree)	Duty (dB)	Limit (dBuV/m)	Margin (dB)
2484.2	53.6 (PK)	1	169	0	74.0(PK)	-20.4
2484.2	35.1 (AV)	1	169	0	54.0(AV)	-19.0

Radiated Emissions (VERTICAL) CH11						
Frequency (MHz)	Amplitude (dBuV/m)	Ant. (m)	Table (Degree)	Duty (dB)	Limit (dBuV/m)	Margin (dB)
2484.4	66.9 (PK)	1	293	0	74.0(PK)	-7.1
2484.4	38.5 (AV)	1	293	0	54.0(AV)	-15.5

- Notes :**
1. Margin= Amplitude - Limits
 2. Height of table for EUT placed: 1.5 Meter.
 3. ANT= Antenna height.
 4. Duty= Duty cycle correction factor.
 5. Amplitude= Reading Amplitude – Amplifier gain+ Cable loss+ Antenna factor
(Auto calculate in spectrum analyzer)

(802.11n HT40)

Radiated Emissions (HORIZONTAL) CH01						
Frequency (MHz)	Amplitude (dBuV/m)	Ant. (m)	Table (Degree)	Duty (dB)	Limit (dBuV/m)	Margin (dB)
2399.7	61.5 (PK)	1	88	0	74.0(PK)	-12.5
2399.7	37.2 (AV)	1	88	0	54.0(AV)	-16.9

Radiated Emissions (VERTICAL) CH01						
Frequency (MHz)	Amplitude (dBuV/m)	Ant. (m)	Table (Degree)	Duty (dB)	Limit (dBuV/m)	Margin (dB)
2399.8	73.9 (PK)	1	170	0	74.0(PK)	-0.1
2399.8	40.2 (AV)	1	170	0	54.0(AV)	-13.8

Radiated Emissions (HORIZONTAL) CH11						
Frequency (MHz)	Amplitude (dBuV/m)	Ant. (m)	Table (Degree)	Duty (dB)	Limit (dBuV/m)	Margin (dB)
2483.7	52.5 (PK)	1	153	0	74.0(PK)	-21.5
2483.7	35.0 (AV)	1	153	0	54.0(AV)	-19.0

Radiated Emissions (VERTICAL) CH11						
Frequency (MHz)	Amplitude (dBuV/m)	Ant. (m)	Table (Degree)	Duty (dB)	Limit (dBuV/m)	Margin (dB)
2484.3	72.2 (PK)	1	288	0	74.0(PK)	-1.8
2484.3	45.1 (AV)	1	288	0	54.0(AV)	-8.9

- Notes :**
1. Margin= Amplitude - Limits
 2. Height of table for EUT placed: 1.5 Meter.
 3. ANT= Antenna height.
 4. Duty= Duty cycle correction factor.
 5. Amplitude= Reading Amplitude – Amplifier gain+ Cable loss+ Antenna factor
(Auto calculate in spectrum analyzer)

9. Antenna Requirements

9.1 Standard Applicable :

For intentional device, according to 15.203, an intentional radiator shall be designed to ensure that no antenna other than that furnished by the responsible party shall be used with the device.

According to 15.247 (b), if transmitting antennas of directional gain greater than 6 dBi are used, the power shall be reduced by the amount in dB that the directional gain of the antenna exceeds 6dBi.

9.2 Antenna Construction

	Model No	ANT TYPE	GAIN	type of connector
1	EDA-1313-2G4C1-A34	Dipole	2.0dBi	N/A

Appendix I - EUT Test Setup

MEASUREMENT OF RADIATED EMISSION

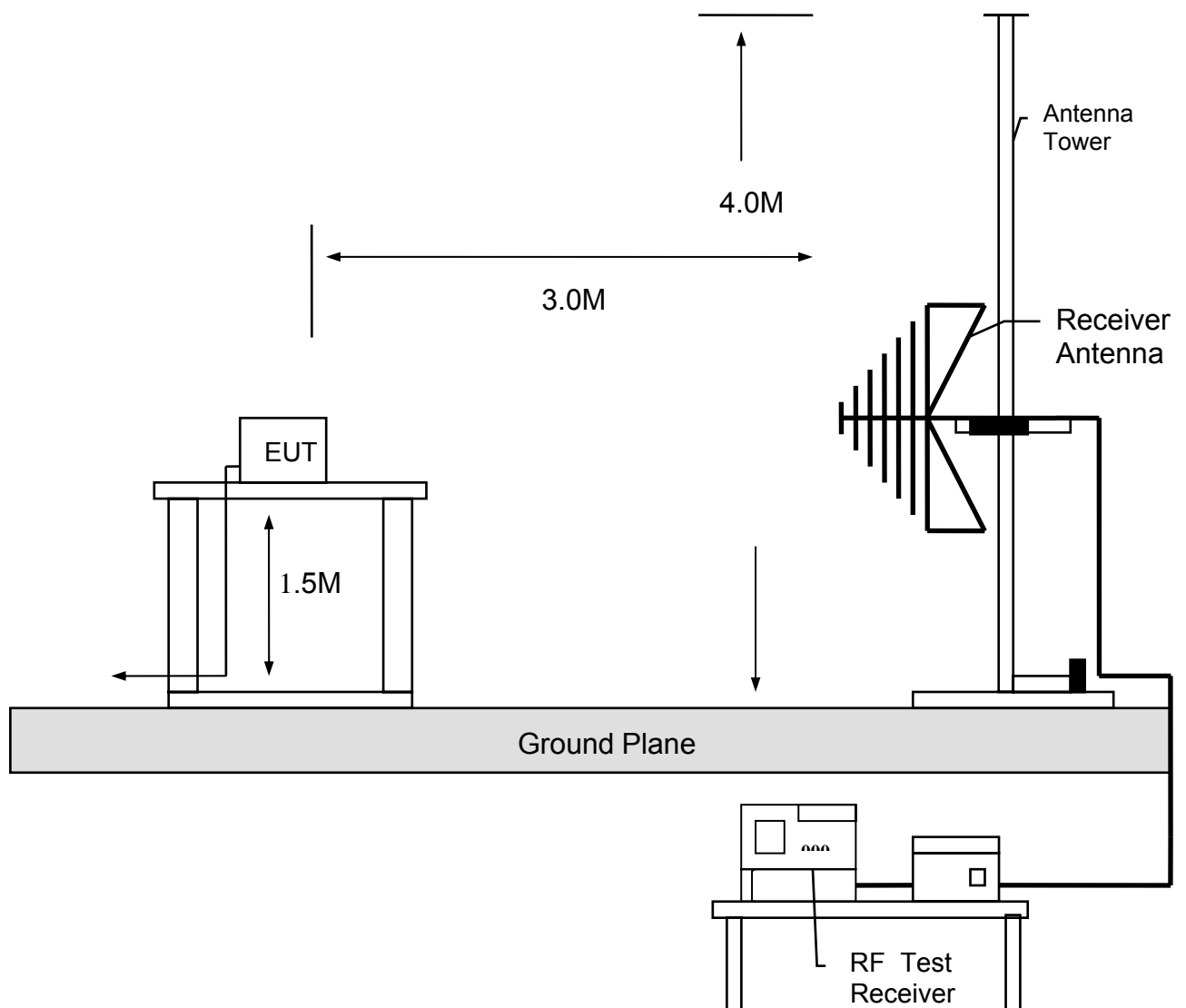

Appendix II - Brand / Trade Name & Model No. Multiple Listee

Trade Name	Model No.
COMTREND	WR-6891u WAP-5891u

Note: The two model listed above are the same product, it just for the different market.