

BCM5356

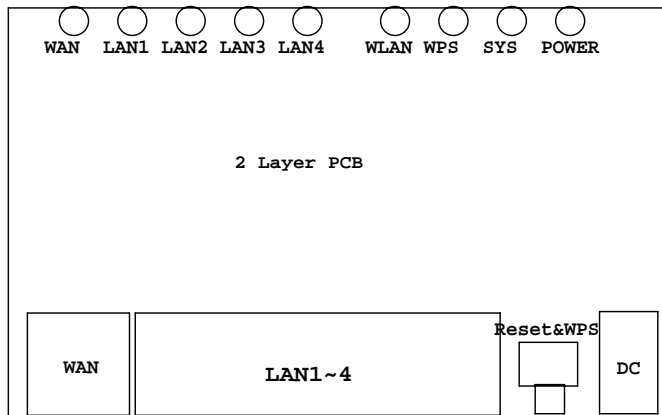
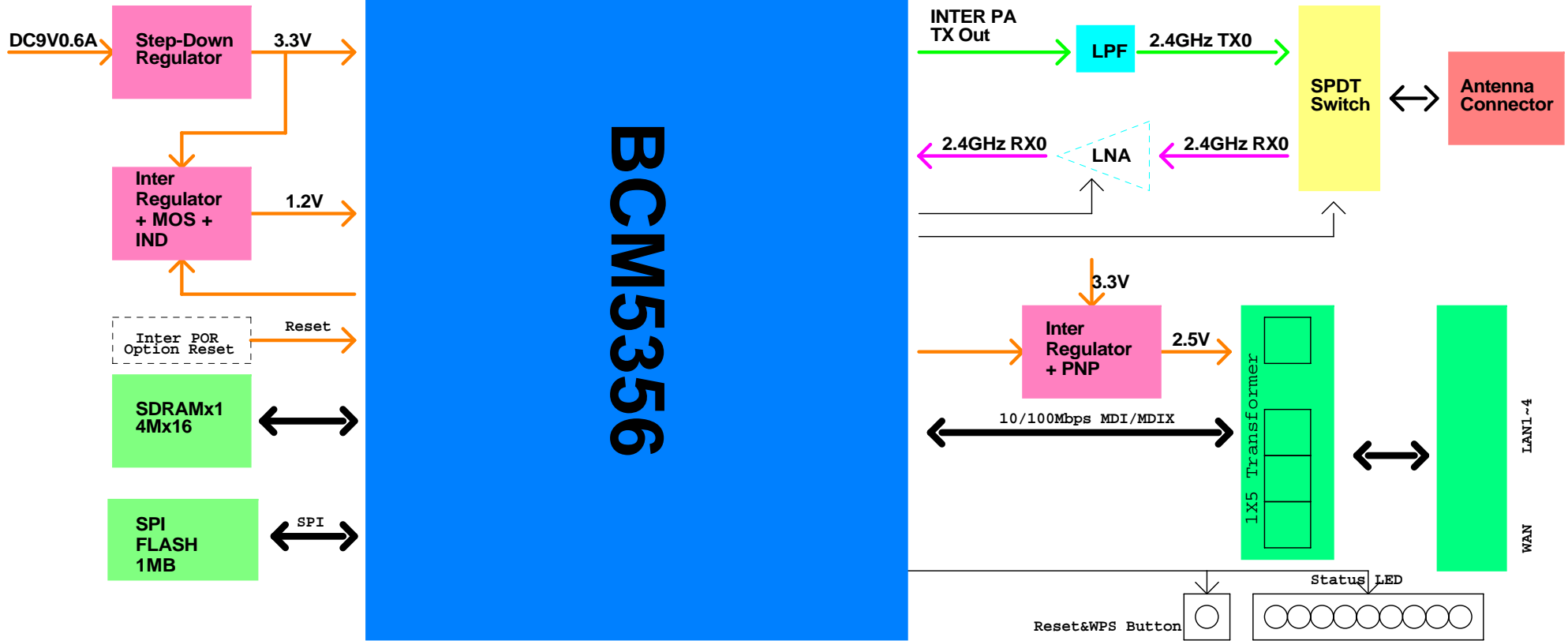

25MHz XTAL

参考文件

基于BCM5356最新原理图824-117040-0000_P502.pdf, 参考W316R_v0.1, 在此基础上修改为W316R_V0.11。

修改记录

1. 去掉了磁珠L16, L17和滤波器U8。
2. L15由4.7uh更改3.3uh. R54;R69;R86;R82;R60;R87由0R改为22R. R5由10K改为4.7K. L11, L12由600R-100M-0402, LF换成220R-100M-0402; 500mA. C103由22P改为10P, C105由47P改为18P. L13由0R改为600R-100M-0402, LF. C106由0.1u改为10u。

TENDA			
Title			
W316R V0.11			
Size	Document Number	Rev	
B	1_Cover Page	0.11	
Date:	Tuesday, October 12, 2010	Sheet	1 of 7