

FCC 47 CFR PART 15 SUBPART C

Product Type : Wireless ADSL2+Router
Applicant : Comtrend Corporation
Address : 3F-1, 10 Lane 609, Chung Hsin Road, Section 5 San Chung
City, Taipei Hsien, Taiwan 241
Trade Name : COMTREND
Model Number : CT-5367
Test Specification : FCC 47 CFR PART 15 SUBPART C: Oct, 2009
Canada RSS-210 ISSUE 7: Jun., 2007
Canada RSS-Gen ISSUE 2: Jun., 2007
ANSI C63.4-2003
Issue Date : Jul. 27, 2010

Issue by

A Test Lab Techno Corp.
No. 140-1, Changan Street, Bade City,
Taoyuan County 334, Taiwan R.O.C.
Tel : +86-3-2710188 / Fax : +86-3-2710190



Taiwan Accreditation Foundation accreditation number: 1330

Note: This report shall not be reproduced except in full, without the written approval of A Test Lab Techno Corp. This document may be altered or revised by A Test Lab Techno Corp. personnel only, and shall be noted in the revision section of the document. The client should not use it to claim product endorsement by TAF, or any government agencies. The test results in the report only apply to the tested sample.

Revision History

Rev.	Issue Date	Revisions	Revised By
00	Jul. 27, 2010	Initial Issue	

Verification

Issued Date: 2010/07/27

Product Type : Wireless ADSL2+Router
Applicant : Comtrend Corporation
Address : 3F-1, 10 Lane 609, Chung Hsin Road, Section 5 San
Chung City, Taipei Hsien, Taiwan 241
Trade Name : COMTREND
Model Number : CT-5367
FCC ID : L9V-5367
EUT Rated Voltage : DC 18V, 5.0A
Test Voltage : 120 Vac / 60 Hz
Applicable Standard : FCC 47 CFR PART 15 SUBPART C: Oct, 2009
Canada RSS-210 ISSUE 7: Jun., 2007
Canada RSS-Gen ISSUE 2: Jun., 2007
ANSI C63.4-2003

Test Result : Complied

Performing Lab. : A Test Lab Techno Corp.

No. 140-1, Changan Street, Bade City,
Taoyuan County 334, Taiwan R.O.C.

Tel : +86-3-2710188 / Fax : +86-3-2710190

Taiwan Accreditation Foundation accreditation number:
1330



<http://www.atl-lab.com.tw/e-index.htm>

The above equipment was tested by A Test Lab Techno Corp. The test data, data evaluation, test procedures, and equipment configurations shown in this report were made in accordance with the procedures given in ANSI C63.4: 2003 and the energy emitted by the sample tested as described in this report is in compliance with the requirements of FCC Rules Part 15.207, 15.209, 15.247 .

The test results of this report relate only to the tested sample identified in this report.

Approved By : 
(Manager) (Miller Lee)

Reviewed By : 
(Testing Engineer) (Gary Wu)

TABLE OF CONTENTS

1	General Information	6
2	EUT Description	7
3	Test Methodology.....	8
	3.1. Mode of Operation.....	8
	3.2. EUT Exercise Software.....	8
	3.3. Configuration of Test System Details.....	9
	3.4. Test Site Environment.....	9
4	Conducted Emission Measurement	10
	4.1. Limit	10
	4.2. Test Instruments	10
	4.3. Test Setup.....	10
	4.4. Test Procedure.....	11
	4.5. Test Result.....	12
5	Radiated Interference Measurement	14
	5.1. Limit	14
	5.2. Test Instruments	14
	5.3. Setup	15
	5.4. Test Procedure.....	15
	5.5. Test Result.....	17
6	Maximum Conducted Output Power Measurement	23
	6.1. Limit	23
	6.2. Test Setup.....	23
	6.3. Test Instruments	23
	6.4. Test Procedure.....	23
	6.5. Test Result.....	24
7	6dB RF Bandwidth Measurement	25
	7.1. Limit	25
	7.2. Test Setup.....	25
	7.3. Test Instruments	25
	7.4. Test Procedure.....	25
	7.5. Test Result.....	26
	7.6. Test Graphs	27
8	Maximum Power Density Measurement.....	29
	8.1. Limit	29
	8.2. Test Setup.....	29
	8.3. Test Instruments	29
	8.4. Test Procedure.....	29
	8.5. Test Result.....	30
	8.6. Test Graphs	31

9	Out of Band Conducted Emissions Measurement	33
9.1.	Limit	33
9.2.	Test Setup.....	33
9.3.	Test Instruments	33
9.4.	Test Procedure.....	33
9.5.	Test Graphs	34
10	Band Edges Measurement	36
10.1.	Limit	36
10.2.	Test Setup.....	36
10.3.	Test Instruments	36
10.4.	Test Procedure.....	37
10.5.	Test Result.....	38
11	99 % Occupied Bandwidth Measurement.....	46
11.1.	Limit	46
11.2.	Test Setup.....	46
11.3.	Test Instruments	46
11.4.	Test Procedure.....	46
11.5.	Test Result.....	47
11.6.	Test Graphs	48
12	Antenna Measurement.....	50
12.1.	Limit	50
12.2.	Antenna Connector Construction	50

1 General Information

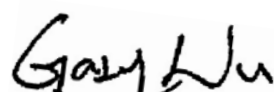
1.1 Summary of Test Result

Standard		Item	Result	Remark
15.247	RSS-GEN			
15.207	7.2.2	AC Power Conducted Emission	PASS	-----
-----	6	Receiver Radiated Emissions	PASS	-----
Standard		Item	Result	Remark
15.247	RSS-210			
15.247(d)	A8.5	Transmitter Radiated Emissions	PASS	-----
15.247(b)(3)	A8.4	Max. Output Power	PASS	-----
15.247(a)(2)	A8.2 (a)	6dB RF Bandwidth	PASS	-----
15.247(e)	A8.2 (b)	Power Spectral Density	PASS	-----
15.247(c)	A8.5	Out of Band Conducted Spurious Emission	PASS	-----
15.247(d)	A8.5	Band Edge Measurement	PASS	-----
15.247(c)	A8.5	Occupied Bandwidth Measurement	PASS	-----
15.203	-	Antenna Requirement	PASS	-----

The test results of this report relate only to the tested sample(s) identified in this report. Manufacturer or whom it may concern should recognize the pass or fail of the test result.

1.2 Measurement Uncertainty

Conducted Emission

The measurement uncertainty is evaluated as ± 2.24 dB.

Radiated Emission

The measurement uncertainty of 30 MHz - 1GHz is evaluated as ± 3.072 dB.

2 EUT Description

Product	:	Wireless ADSL2+Router
Trade Name	:	COMTREND
Model No.	:	CT-5367
Applicant	:	Comtrend Corporation 3F-1, 10 Lane 609, Chung Hsin Road, Section 5 San Chung City, Taipei Hsien, Taiwan 241
Manufacturer	:	Comtrend Corporation 3F-1, 10 Lane 609, Chung Hsin Road, Section 5 San Chung City, Taipei Hsien, Taiwan 241
FCC ID	:	L9V-5367
Frequency Range	:	2412 ~ 2462 MHz
Modulation Type	:	IEEE 802.11b:DSSS(CCK, DQPSK, DBPSK) IEEE 802.11g:DSSS(CCK, DQPSK, DBPSK)+ OFDM(QPSK, BPSK, 16-QAM, 64-QAM)
Antenna Type	:	External Type
Antenna Gain	:	2 dBi
RF Output Power	:	IEEE 802.11b: 0.028 W / 14.48 dBm IEEE 802.11g: 0.047 W / 16.74 dBm
Component		
Power Adapter	:	ELEMENTECH, AU1091806u Input:100-240Vac, 50-60Hz, 0.5A Output: 18Vdc, 5.0A Cable out: Non-Shielded, 1.54 m

3 Test Methodology

3.1. Mode of Operation

Decision of Test ATL has verified the construction and function in typical operation. All the test modes were carried out with the EUT in normal operation, which was shown in this test report and defined as:

Test Mode
Mode 1: Normal Operation Mode
Mode 2: IEEE 802.11b Link Mode
Mode 3: IEEE 802.11g Link Mode
Mode 4: Receiver Mode

Software used to control the EUT for staying in continuous transmitting mode was programmed.

After verification, all tests were carried out with the worst case test modes as shown below except radiated spurious emission below 1GHz and power line conducted emissions below 30MHz, which worst case was in normal link mode only.

IEEE 802.11b mode:

Channel Low (2412MHz), Channel Mid (2437MHz) and Channel High (2462MHz) with 11Mbps data rate were chosen for full testing.

IEEE 802.11g mode:

Channel Low (2412MHz), Channel Mid (2437MHz) and Channel High (2462MHz) with 6Mbps data rate were chosen for full testing.

3.2. EUT Exercise Software

1.	Setup the EUT shown on 3.3.
2.	Turn on the power of all equipment.
3.	Turn on Wi-Fi function link to AP.
4.	EUT run test program.

3.3. Configuration of Test System Details

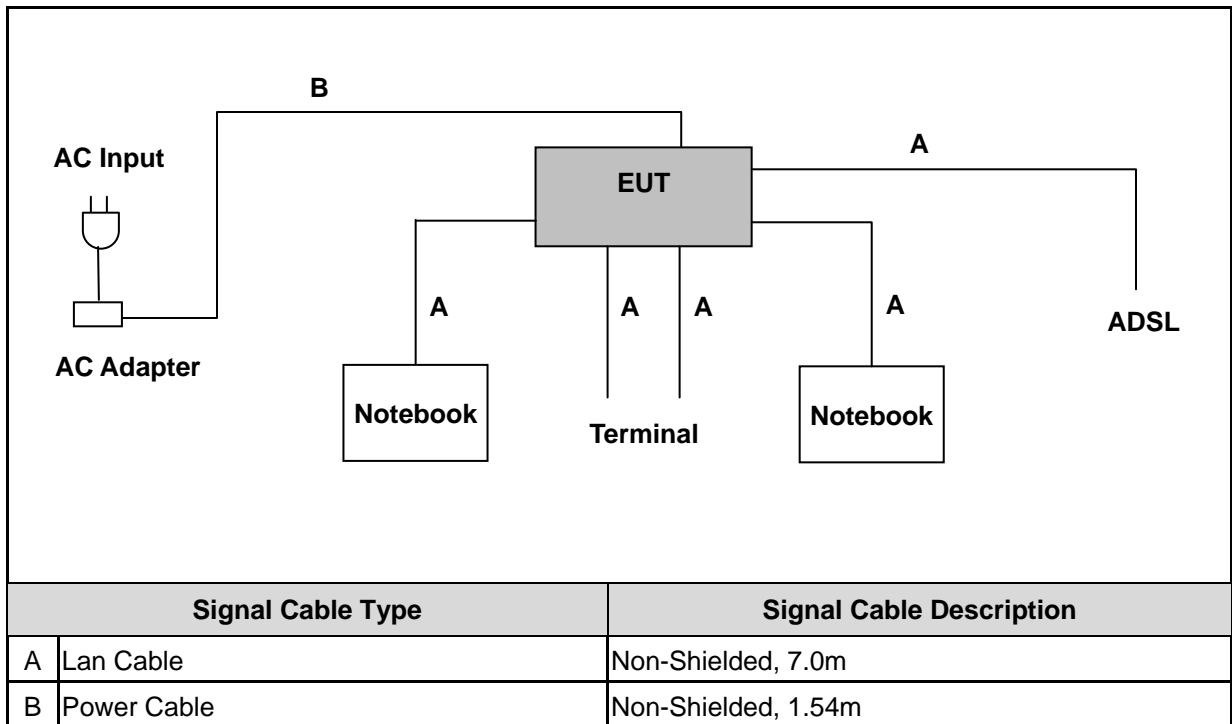

Devices Description					
	Product	Manufacturer	Model Number	Serial Number	Power Cord
1.	Notebook	Dell	D531	GDCD-T6HYQ-3MQ8R-JCPD3-3G8G2	Non-Shielded, 1.8m
2.	Notebook	Dell	D531	CN-OXM006-48643-87A-3398	Non-Shielded, 1.8m

3.4. Test Site Environment

Items	Required (IEC 68-1)	Actual
Temperature (°C)	15-35	25
Humidity (%RH)	25-75	50
Barometric pressure (mbar)	860-1060	950

4 Conducted Emission Measurement

4.1. Limit

Frequency (MHz)	Quasi-peak	Average
0.15 - 0.5	66 to 56	56 to 46
0.50 - 5.0	56	46
5.0 - 30.0	60	50

4.2. Test Instruments

Describe	Manufacturer	Model Number	Serial Number	Cal. Date	Remark
Test Receiver	R&S	ESCI	100367	07/01/2010	(1)
LISN	R&S	ENV216	101040	03/02/2010	(1)
LISN	R&S	ENV216	101041	03/02/2010	(1)
Test Site	ATL	TE02	TE02	N.C.R.	-----

Remark: ⁽¹⁾ Calibration period 1 year. ⁽²⁾ Calibration period 2 years.

NOTE: N.C.R. = No Calibration Request.

4.3. Test Setup

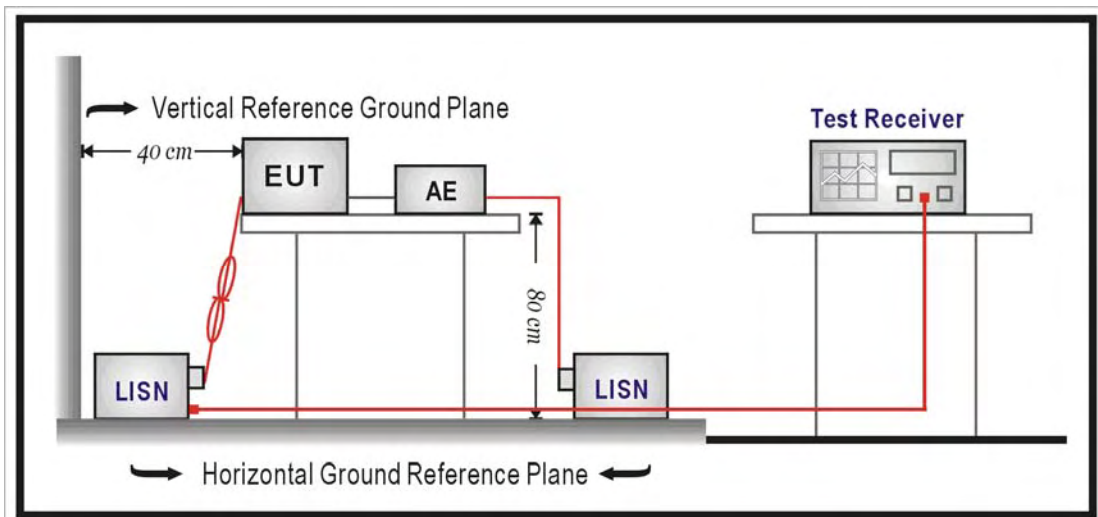

4.4. Test Procedure

The power line conducted emission measurements were performed in a shielded enclosure. The EUT was assembled on a wooden table which is 80 centimeters high, was placed 40 centimeters from the back wall and at least 1 meter from the sidewall.

Power was fed to the EUT from the public utility power grid through a line filter and EMCO Model 3162/2 SH Line Impedance Stabilization Networks (LISN). The LISN housing, measuring instrumentation case, ground plane, etc., were electrically bonded together at the same RF potential. The Spectrum analyzer was connected to the AC line through an isolation transformer. The 50-ohm output of the LISN was connected to the spectrum analyzer directly. Conducted emission levels were in the CISPR quasi-peak detection mode. The analyzer's 6 dB bandwidth was set to 9 KHz. No post-detector video filter was used.

The spectrum was scanned from 150 KHz to 30 MHz. The physical arrangement of the test system and associated cabling was varied (within the scope of arrangements likely to be encountered in actual use) to determine the effect on the unit's emanations in amplitude and frequency. All spurious emission frequencies were observed. The highest emission amplitudes relative to the appropriate limit were measured and have been recorded in paragraph 4.1.

4.5. Test Result

Standard:	FCC Part 15C	Line:	L1
Test item:	Conducted Emission	Power:	AC 120V/60Hz
Model:	CT-5367	Temp.(°C)/Hum.(%RH):	26(°C)/60%RH
Mode:	Mode 1	Date:	2010/07/07
		Test By:	Gary Wu
Description:			

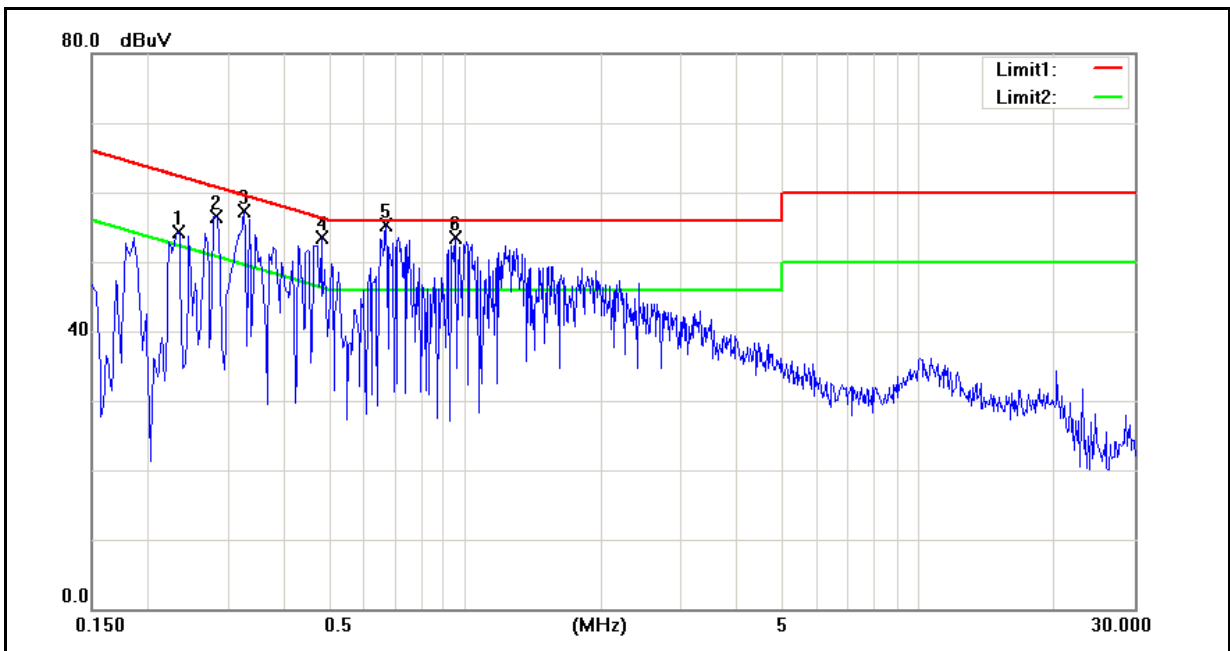

No.	Frequency (MHz)	QP reading (dBuV)	AVG reading (dBuV)	Correction factor (dB)	QP result (dBuV)	AVG result (dBuV)	QP limit (dBuV)	AVG limit (dBuV)	QP margin (dB)	AVG margin (dB)	Remark
1	0.2340	43.17	26.37	10.07	53.24	36.44	62.31	52.31	-9.07	-15.87	Pass
2	0.2820	45.28	28.48	10.05	55.33	38.53	60.76	50.76	-5.43	-12.23	Pass
3	0.3260	44.36	26.90	10.03	54.39	36.93	59.55	49.55	-5.16	-12.62	Pass
4	0.4820	40.76	20.74	9.97	50.73	30.71	56.30	46.30	-5.57	-15.59	Pass
5	0.6700	40.50	22.56	9.88	50.38	32.44	56.00	46.00	-5.62	-13.56	Pass
6	0.9580	39.95	21.66	9.78	49.73	31.44	56.00	46.00	-6.27	-14.56	Pass

Standard:	FCC Part 15C	Line:	N
Test item:	Conducted Emission	Power:	AC 120V/60Hz
Model:	CT-5367	Temp.(°C)/Hum.(%RH):	26(°C)/60%RH
Mode:	Mode 1	Date:	2010/07/07
		Test By:	Gary Wu
Description:			

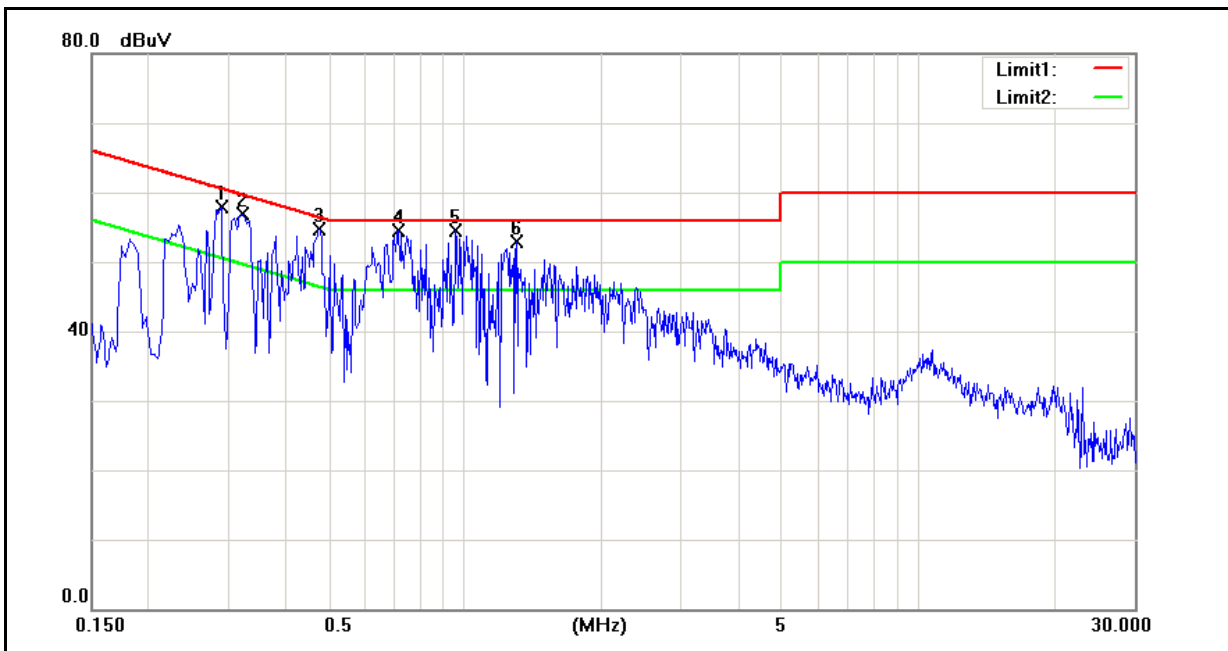

No.	Frequency (MHz)	QP reading (dBuV)	AVG reading (dBuV)	Correction factor (dB)	QP result (dBuV)	AVG result (dBuV)	QP limit (dBuV)	AVG limit (dBuV)	QP margin (dB)	AVG margin (dB)	Remark
1	0.2900	43.57	24.87	10.03	53.60	34.90	60.52	50.52	-6.92	-15.62	Pass
2	0.3220	43.97	25.76	10.03	54.00	35.79	59.66	49.66	-5.66	-13.87	Pass
3	0.4780	41.16	21.78	9.97	51.13	31.75	56.37	46.37	-5.24	-14.62	Pass
4	0.7140	40.94	23.01	9.86	50.80	32.87	56.00	46.00	-5.20	-13.13	Pass
5	0.9580	40.21	21.64	9.77	49.98	31.41	56.00	46.00	-6.02	-14.59	Pass
6	1.2980	38.26	19.29	9.62	47.88	28.91	56.00	46.00	-8.12	-17.09	Pass

5 Radiated Interference Measurement

5.1. Limit

Frequency Range (MHz)	Peak (dBuV)
30 to 88	40
88 to 216	43.5
216 to 960	46
Above 960	54

5.2. Test Instruments

3 Meter Chamber					
Equipment	Manufacturer	Model Number	Serial Number	Cal. Date	Remark
RF Pre-selector	Agilent	N9039A	MY46520256	01/27/2009	(2)
Spectrum Analyzer	Agilent	E4446A	MY46180578	01/20/2009	(2)
Pre Amplifier	Agilent	8449B	3008A02237	02/24/2010	(1)
Pre Amplifier	Agilent	8447D	2944A10961	02/24/2010	(1)
Bi-log Antenna	SCHWARZBECK MESS-ELEKTRONIK	VULB9163	9163-270	06/23/2009	(2)
Horn Antenna	SCHWARZBECK MESS-ELEKTRONIK	BBHA9120D	9120D-550	07/01/2009	(2)
Horn Antenna	SCHWARZBECK MESS-ELEKTRONIK	BBHA9170	9170-320	06/30/2009	(2)
Test Site	ATL	TE01	888001	08/06/2009	(1)

Remark: ⁽¹⁾ Calibration period 1 year. ⁽²⁾ Calibration period 2 years.

NOTE: N.C.R. = No Calibration Request.

5.3. Setup

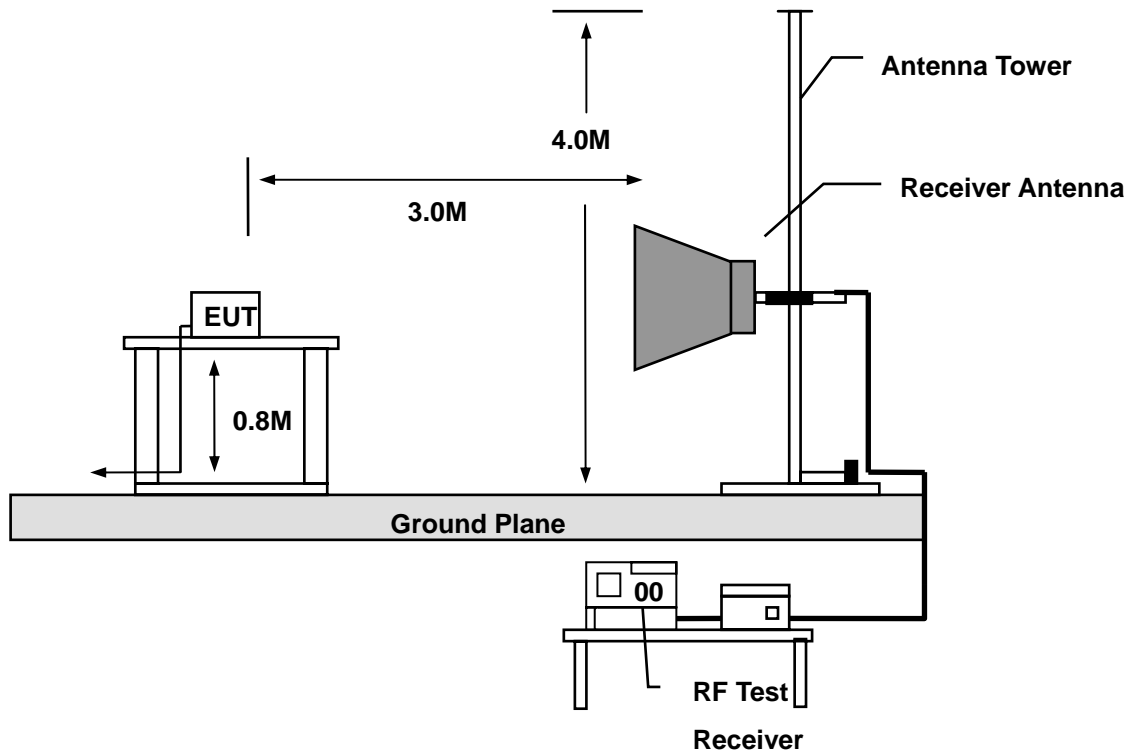

5.4. Test Procedure

Final radiation measurements were made on a three-meter, Semi Anechoic Chamber. The EUT system was placed on a nonconductive turntable which is 0.8 meters height, top surface 1.0 x 1.5 meter. The spectrum was examined from 250 MHz to 2.5 GHz in order to cover the whole spectrum below 10th harmonic which could generate from the EUT. During the test, EUT was set to transmit continuously & Measurements spectrum range from 30 MHz to 26.5 GHz is investigated.

For measurements below 1 GHz the resolution bandwidth is set to 100 kHz for peak detection measurements or 120 kHz for quasi-peak detection measurements. Peak detection is used unless otherwise noted as quasi-peak.

For measurements above 1 GHz the resolution bandwidth is set to 1 MHz, and then the video bandwidth is set to 1 MHz for peak measurements and 10 Hz for average measurements.

A nonconductive material surrounded the EUT to supporting the EUT for standing on three orthogonal planes. At each condition, the EUT was rotated 360 degrees, and the antenna was raised and lowered from one to four meters to find the maximum emission levels. Measurements were taken using both horizontal and vertical antenna polarization.

SCHWARZBECK MESS-ELEKTRONIK Biconilog Antenna (mode VULB9163) at 3 Meter and the SCHWARZBECK Double Ridged Guide Antenna (model BBHA9120D&9170) was used in frequencies 1 – 26.5 GHz at a distance of 1 meter. All test results were extrapolated to equivalent signal at 3 meters utilizing an inverse linear distance extrapolation Factor (20dB/decade).

For testing above 1GHz, the emission level of the EUT in peak mode was 20dB lower than average limit (that means the emission level in peak mode also complies with the limit in average mode), then testing will be stopped and peak values of EUT will be reported, otherwise, the emissions will be measured in average mode again and reported.

Appropriate preamplifiers were used for improving sensitivity and precautions were taken to avoid overloading or desensitizing the spectrum analyzer. No post – detector video filters were used in the test.

The spectrum analyzer's 6 dB bandwidth was set to 1 MHz, and the analyzer was operated in the peak detection mode, for frequencies both below and up 1 GHz. The average levels were obtained by subtracting the duty cycle correction factor from the peak readings.

The following procedures were used to convert the emission levels measured in decibels referenced to 1 microvolt (dBuV) into field intensity in micro volts per meter (uV/m).

The actual field intensity in decibels referenced to 1 microvolt in to field intensity in micro volts per meter (dBuV/m).

The actual field intensity in decibels referenced to 1 microvolt per meter (dBuV/m) is determined by algebraically adding the measured reading in dBuV, the antenna factor (dB), and cable loss (dB) and Subtracting the gain of preamplifier (dB) is auto calculate in spectrum analyzer.

$$(1) \text{ Amplitude (dBuV/m) = FI (dBuV) +AF (dBuV) +CL (dBuV)-Gain (dB)}$$

FI= Reading of the field intensity.

AF= Antenna factor.

CL= Cable loss.

P.S Amplitude is auto calculate in spectrum analyzer.

$$(2) \text{ Actual Amplitude (dBuV/m) = Amplitude (dBuV)-Dis(dB)}$$

The FCC specified emission limits were calculated according the EUT operating frequency and by following linear interpolation equations:

(a) For fundamental frequency : Transmitter Output < +30dBm

(b) For spurious frequency : Spurious emission limits = fundamental emission limit /10

5.5. Test Result

5.5.1. Below 1GHz

Standard:	FCC Part 15C	Test Distance:	3m
Test item:	Radiated Emission	Power:	AC 120V/60Hz
Model:	CT-5367	Temp.(°C)/Hum.(%RH):	26(°C)/60%RH
Mode:	Mode 1	Date:	2010/07/15
Ant.Polar.:	Horizontal	Test By:	Gary Wu

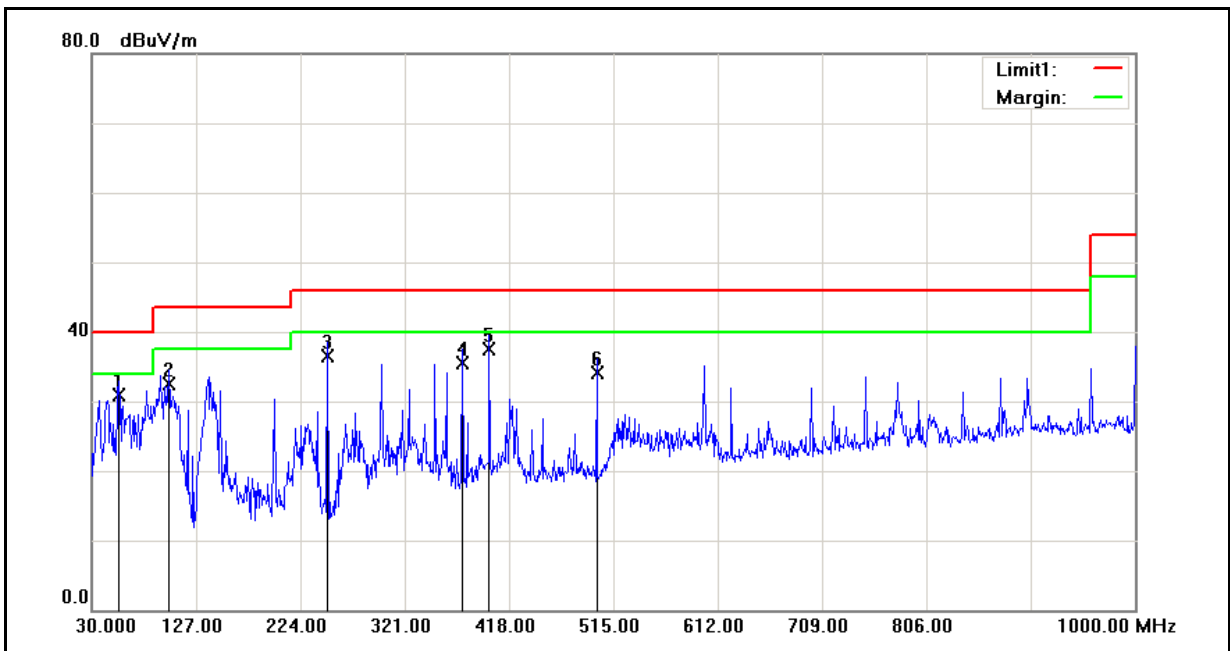

No.	Frequency (MHz)	Reading (dBuV)	Correct Factor(dB/m)	Result (dBuV/m)	Limit (dBuV/m)	Margin (dB)	Remark
1	56.0000	43.13	-12.32	30.81	40.00	-9.19	QP
2	102.0000	46.09	-13.51	32.58	43.50	-10.92	QP
3	250.0000	48.50	-11.95	36.55	46.00	-9.45	QP
4	375.0000	44.22	-8.62	35.60	46.00	-10.40	QP
5	400.0000	46.04	-8.60	37.44	46.00	-8.56	QP
6	500.0000	40.89	-6.79	34.10	46.00	-11.90	QP

Standard:	FCC Part 15C	Test Distance:	3m
Test item:	Radiated Emission	Power:	AC 120V/60Hz
Model:	CT-5367	Temp.(°C)/Hum.(%RH):	26(°C)/60%RH
Mode:	Mode 1	Date:	2010/07/15
Ant.Polar.:	Vertical	Test By:	Gary Wu

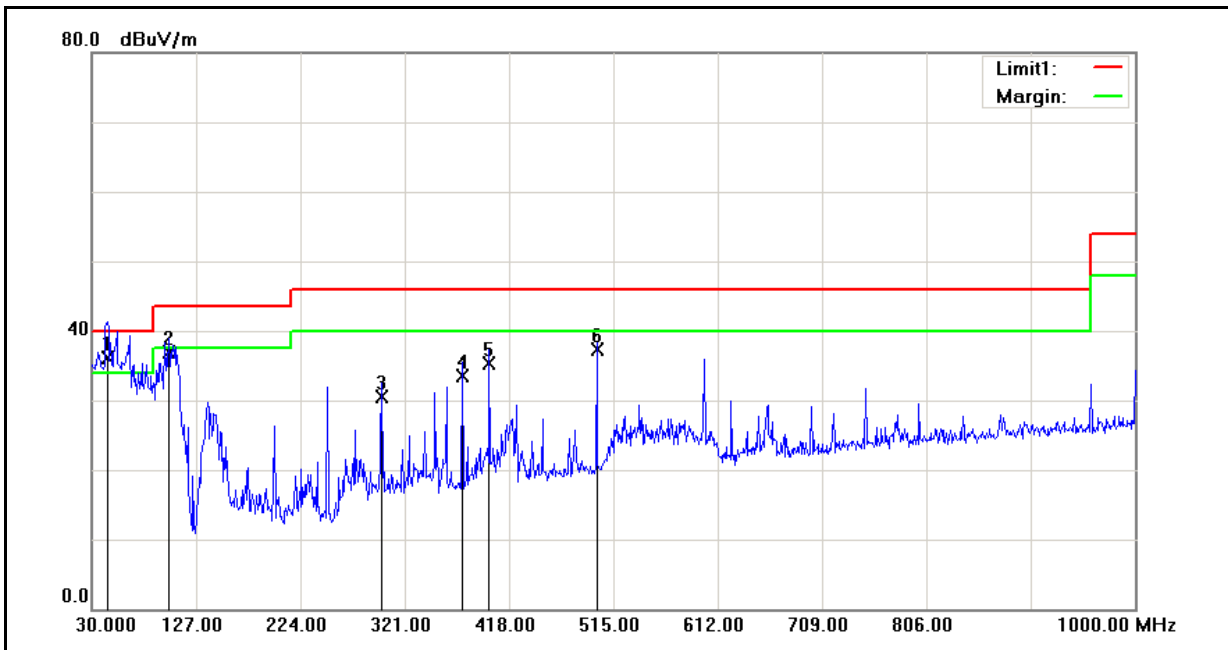

No.	Frequency (MHz)	Reading (dBuV)	Correct Factor(dB/m)	Result (dBuV/m)	Limit (dBuV/m)	Margin (dB)	Remark
1	45.5000	47.78	-11.62	36.16	40.00	-3.84	QP
2	102.0000	50.38	-13.51	36.87	43.50	-6.63	QP
3	300.0000	41.09	-10.63	30.46	46.00	-15.54	QP
4	375.0000	42.04	-8.62	33.42	46.00	-12.58	QP
5	400.0000	43.96	-8.60	35.36	46.00	-10.64	QP
6	500.0000	44.04	-6.79	37.25	46.00	-8.75	QP

5.5.2. Above 1GHz

Standard:		FCC Part 15C		Test Distance:		3m	
Test item:		Radiated Emission		Power:		AC 120V/60Hz	
Model:		CT-5367		Temp.(°C)/Hum.(%RH):		26(°C)/60%RH	
Mode:		Mode 2		Date:		2010/07/15	
Frequency:		2412MHz		Test By:		Gary Wu	
Frequency (MHz)	Reading (dBuV)	Correct Factor(dB/m)	Result (dBuV/m)	Limit (dBuV/m)	Margin (dB)	Remark	Ant.Polar. H / V
1609.000	48.13	-3.17	44.96	74.00	-29.04	peak	H
1763.000	52.64	-2.63	50.01	74.00	-23.99	peak	H
4824.000	36.05	7.92	43.97	74.00	-30.03	peak	H
7236.000	35.48	15.03	50.51	74.00	-23.49	peak	H
1609.000	46.88	-3.17	43.71	74.00	-30.29	peak	V
1763.000	46.57	-2.63	43.94	74.00	-30.06	peak	V
4824.000	38.92	7.92	46.84	74.00	-27.16	peak	V
7236.000	36.32	15.03	51.35	74.00	-22.65	peak	V

Standard:		FCC Part 15C		Test Distance:		3m	
Test item:		Radiated Emission		Power:		AC 120V/60Hz	
Model:		CT-5367		Temp.(°C)/Hum.(%RH):		26(°C)/60%RH	
Mode:		Mode 2		Date:		2010/07/15	
Frequency:		2437MHz		Test By:		Gary Wu	
Frequency (MHz)	Reading (dBuV)	Correct Factor(dB/m)	Result (dBuV/m)	Limit (dBuV/m)	Margin (dB)	Remark	Ant.Polar. H / V
1623.000	44.27	-3.13	41.14	74.00	-32.86	peak	H
1763.000	45.41	-2.63	42.78	74.00	-31.22	peak	H
4874.000	35.62	8.09	43.71	74.00	-30.29	peak	H
7311.000	34.97	15.23	50.20	74.00	-23.80	peak	H
1623.000	47.54	-3.13	44.41	74.00	-29.59	peak	V
1763.000	45.63	-2.63	43.00	74.00	-31.00	peak	V
4874.000	41.23	8.09	49.32	74.00	-24.68	peak	V
7311.000	35.58	15.23	50.81	74.00	-23.19	peak	V

Standard:		FCC Part 15C		Test Distance:		3m	
Test item:		Radiated Emission		Power:		AC 120V/60Hz	
Model:		CT-5367		Temp.(°C)/Hum.(%RH):		26(°C)/60%RH	
Mode:		Mode 2		Date:		2010/07/15	
Frequency:		2462MHz		Test By:		Gary Wu	
Frequency (MHz)	Reading (dBuV)	Correct Factor(dB/m)	Result (dBuV/m)	Limit (dBuV/m)	Margin (dB)	Remark	Ant.Polar. H / V
1644.000	51.77	-3.05	48.72	74.00	-25.28	peak	H
1763.000	53.12	-2.63	50.49	74.00	-23.51	peak	H
4924.000	36.00	8.25	44.25	74.00	-29.75	peak	H
7386.000	33.56	15.42	48.98	74.00	-25.02	peak	H
1644.000	47.70	-3.05	44.65	74.00	-29.35	peak	V
1763.000	45.53	-2.63	42.90	74.00	-31.10	peak	V
4924.000	40.93	8.25	49.18	74.00	-24.82	peak	V
7386.000	34.77	15.42	50.19	74.00	-23.81	peak	V

Standard:		FCC Part 15C		Test Distance:		3m	
Test item:		Radiated Emission		Power:		AC 120V/60Hz	
Model:		CT-5367		Temp.(°C)/Hum.(%RH):		26(°C)/60%RH	
Mode:		Mode 3		Date:		2010/07/15	
Frequency:		2412MHz		Test By:		Gary Wu	
Frequency (MHz)	Reading (dBuV)	Correct Factor(dB/m)	Result (dBuV/m)	Limit (dBuV/m)	Margin (dB)	Remark	Ant.Polar. H / V
1609.000	49.05	-3.17	45.88	74.00	-28.12	peak	H
1763.000	52.78	-2.63	50.15	74.00	-23.85	peak	H
4824.000	35.65	7.92	43.57	74.00	-30.43	peak	H
7236.000	35.40	15.03	50.43	74.00	-23.57	peak	H
1609.000	46.75	-3.17	43.58	74.00	-30.42	peak	V
1763.000	44.62	-2.63	41.99	74.00	-32.01	peak	V
4824.000	40.89	7.92	48.81	74.00	-25.19	peak	V
7236.000	41.91	15.03	56.94	74.00	-17.06	peak	V
7236.000	26.44	15.03	41.47	54.00	-12.53	AVG	V

Standard:	FCC Part 15C		Test Distance:	3m			
Test item:	Radiated Emission		Power:	AC 120V/60Hz			
Model:	CT-5367		Temp.(°C)/Hum.(%RH):	26(°C)/60%RH			
Mode:	Mode 3		Date:	2010/07/15			
Frequency:	2437MHz		Test By:	Gary Wu			
Frequency (MHz)	Reading (dBuV)	Correct Factor(dB/m)	Result (dBuV/m)	Limit (dBuV/m)	Margin (dB)	Remark	Ant.Polar. H / V
1623.000	51.23	-3.13	48.10	74.00	-25.90	peak	H
1763.000	53.26	-2.63	50.63	74.00	-23.37	peak	H
4874.000	36.51	8.09	44.60	74.00	-29.40	peak	H
7311.000	35.47	15.23	50.70	74.00	-23.30	peak	H
1623.000	45.62	-3.13	42.49	74.00	-31.51	peak	V
1763.000	44.25	-2.63	41.62	74.00	-32.38	peak	V
4874.000	43.37	8.09	51.46	74.00	-22.54	peak	V
7311.000	41.64	15.23	56.87	74.00	-17.13	peak	V
7311.000	25.45	15.23	40.68	54.00	-13.32	AVG	V

Standard:		FCC Part 15C		Test Distance:		3m	
Test item:		Radiated Emission		Power:		AC 120V/60Hz	
Model:		CT-5367		Temp.(°C)/Hum.(%RH):		26(°C)/60%RH	
Mode:		Mode 3		Date:		2010/07/15	
Frequency:		2462MHz		Test By:		Gary Wu	
Frequency (MHz)	Reading (dBuV)	Correct Factor(dB/m)	Result (dBuV/m)	Limit (dBuV/m)	Margin (dB)	Remark	Ant.Polar. H / V
1644.000	51.30	-3.05	48.25	74.00	-25.75	peak	H
1763.000	53.24	-2.63	50.61	74.00	-23.39	peak	H
4924.000	36.30	8.25	44.55	74.00	-29.45	peak	H
7386.000	35.11	15.42	50.53	74.00	-23.47	peak	H
1644.000	45.87	-3.05	42.82	74.00	-31.18	peak	V
1763.000	46.91	-2.63	44.28	74.00	-29.72	AVG	V
4924.000	46.03	8.25	54.28	74.00	-19.72	peak	V
4924.000	28.54	8.25	36.79	54.00	-17.21	AVG	V
7386.000	39.12	15.42	54.54	74.00	-19.46	peak	V
7386.000	24.95	15.42	40.37	54.00	-13.63	AVG	V

Standard:		FCC Part 15B		Test Distance:		3m		
Test item:		Radiated Emission		Power:		AC 120V/60Hz		
Model:		3G10WVR2		Temp.(°C)/Hum.(%RH):		26(°C)/60%RH		
Mode:		Mode 4		Date:		2010/07/15		
Modulation:		IEEE 802.11b		Test By:		Gary Wu		
Frequency:		2437MHz						
Frequency (MHz)	Reading (dBuV)	Correct Factor(dB/m)	Result (dBuV/m)	Peak Limit (dBuV/m)	AVG. Limit (dBuV/m)	Margin (dB)	Remark	Ant.Polar. H / V
1378.000	44.39	-4.24	40.15	74.00	54.00	-33.85	peak	H
3324.000	41.63	3.02	44.65	74.00	54.00	-29.35	peak	H
1497.000	44.69	-3.58	41.11	74.00	54.00	-32.89	peak	V
6488.000	36.73	12.83	49.56	74.00	54.00	-24.44	peak	V

6 Maximum Conducted Output Power Measurement

6.1. Limit

For systems using digital modulation in the 2400-2483.5MHz, the limit for peak output power is 30dBm.

6.2. Test Setup

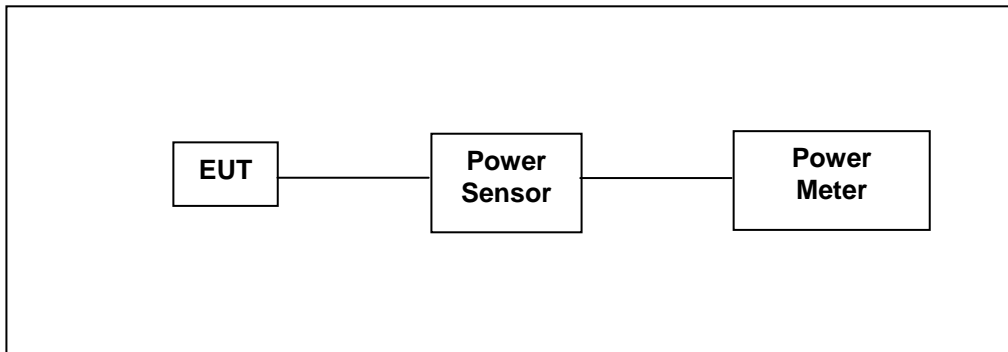

6.3. Test Instruments

Equipment	Manufacturer	Model Number	Serial Number	Cal. Date	Remark
Single Channel PK Power Sensor	Agilent	N1911A	MY45101619	07/19/2010	(1)
Wideband Power Meter	Agilent	N1921A	MY45241957	07/25/2009	(1)
Test Site	ATL	TE06	TE06	N.C.R.	-----

Remark: ⁽¹⁾ Calibration period 1 year. ⁽²⁾ Calibration period 2 years.

NOTE: N.C.R. = No Calibration Request.

6.4. Test Procedure

The tests below are run with the EUT's transmitter set at high power in TX mode. The EUT is needed to force selection of output power level and channel number. While testing, EUT was set to transmit continuously. Remove the Subjective device's antenna and connect the RF output port to power sensor. The maximum peak output power shall not exceed 1 watt.

Use a direct connection between the antenna port of transmitter and the power sensor, for prevent the power sensor input attenuation 40-50 dB. Set the RBW Bandwidth of the emission or use a channel power meter mode.

For antennas with gains of 6 dBi or less, maximum allowed transmitter output is 1 watt (+30 dBm). For antennas with gains greater than 6 dBi, transmitter output level must be decreased by an amount equal to $(\text{GAIN} - 6)/3$ dBm.

The antenna port of the EUT was connected to the input of a power sensor. Power was read directly and cable loss correction was added to the reading to obtain power at the EUT antenna terminals.

6.5. Test Result

Model	CT-5367					
Test Item	Maximum Conducted Output Power					
Test Mode	Mode 2: IEEE 802.11b Link Mode					
Date of Test	07/20/2010			Test Site	TE06	
Frequency (MHz)	Data Rate	Average Power		Peak Power		Limit (dBm)
		(dBm)	(W)	(dBm)	(W)	
2412	1	9.69	0.00931	14.29	0.02685	< 30
2437		9.69	0.00931	14.42	0.02767	< 30
2462		9.44	0.00879	14.16	0.02606	< 30
2412	11	8.88	0.00773	14.36	0.02729	< 30
2437		8.81	0.00760	14.48	0.02805	< 30
2462		8.77	0.00753	14.40	0.02754	< 30

Model	CT-5367					
Test Item	Maximum Conducted Output Power					
Test Mode	Mode 3: IEEE 802.11g Link Mode					
Date of Test	07/20/2010			Test Site	TE06	
Frequency (MHz)	Data Rate	Average Power		Peak Power		Limit (dBm)
		(dBm)	(W)	(dBm)	(W)	
2412	6	9.12	0.00817	16.70	0.04677	< 30
2437		9.24	0.00839	16.74	0.04721	< 30
2462		9.10	0.00813	16.56	0.04529	< 30
2412	54	6.31	0.00428	16.31	0.04276	< 30
2437		6.30	0.00427	16.45	0.04416	< 30
2462		6.32	0.00429	16.36	0.04325	< 30

7 6dB RF Bandwidth Measurement

7.1. Limit

Systems using digital modulation techniques may operate in the 2400–2483.5 MHz bands. The minimum 6 dB band-width shall be at least 500 kHz.

7.2. Test Setup

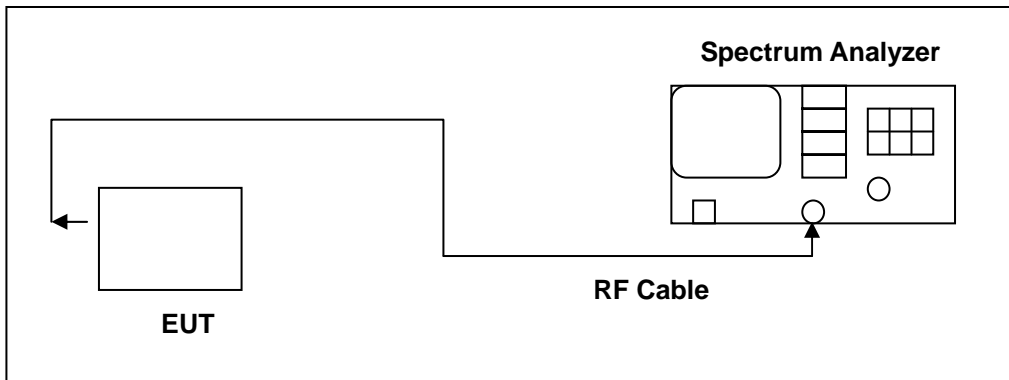

7.3. Test Instruments

Equipment	Manufacturer	Model Number	Serial Number	Cal. Date	Remark
Spectrum Analyzer	Agilent	E4445A	MY46181986	05/14/2009	⁽²⁾
Test Site	ATL	TE06	TE06	N.C.R.	-----

Remark: ⁽¹⁾ Calibration period 1 year. ⁽²⁾ Calibration period 2 years.

NOTE: N.C.R. = No Calibration Request.

7.4. Test Procedure

The EUT was setup to ANSI C63.4, 2003; tested to DTS test procedure of Oct 2002 KDB558074 for compliance to FCC 47CFR 15.247 requirements.

The antenna port of the EUT was connected to the input of a spectrum analyzer. Analyzer RES BW was set to 100 kHz. For each RF output channel investigated, the spectrum analyzer center frequency was set to the channel carrier. A peak output reading was taken, a DISPLAY line was drawn 6 dB lower than peak level. The 6 dB bandwidth was determined from where the channel output spectrum intersected the display line.

The test was performed at 3 channels (Channel 1, 6, 11)

7.5. Test Result

Model	CT-5367		
Test Item	6dB RF Bandwidth		
Test Mode	Mode 2: IEEE 802.11b Link Mode		
Date of Test	07/16/2010	Test Site	TE06
Frequency (MHz)	Measurement (kHz)		Limit (kHz)
2412	9600		> 500
2437	9600		> 500
2462	9225		> 500

Model	CT-5367		
Test Item	6dB RF Bandwidth		
Test Mode	Mode 3: IEEE 802.11g Link Mode		
Date of Test	07/16/2010	Test Site	TE06
Frequency (MHz)	Measurement (kHz)		Limit (kHz)
2412	15750		> 500
2437	16200		> 500
2462	15675		> 500

7.6. Test Graphs

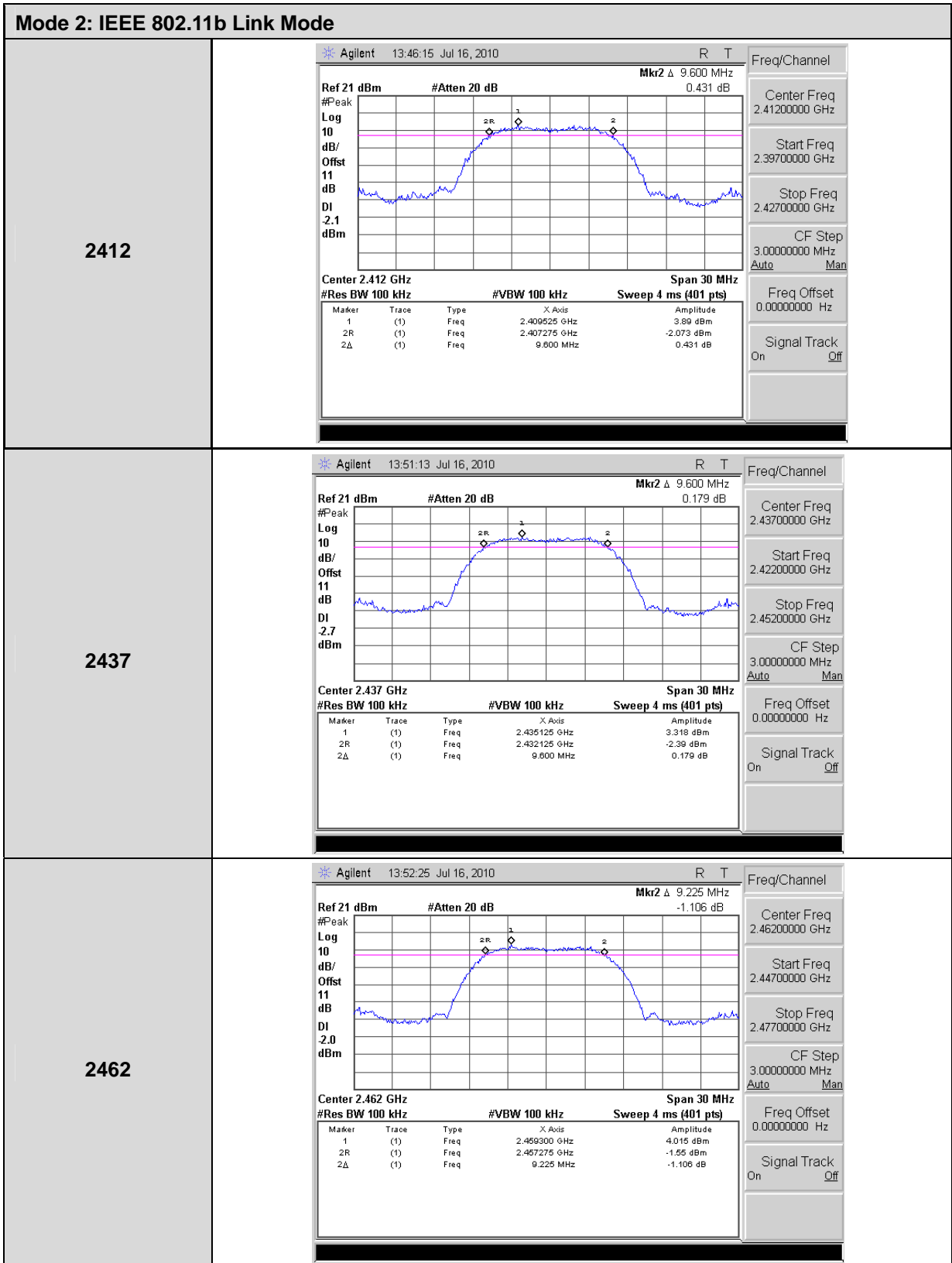

Mode 3: IEEE 802.11g Link Mode

<p>2412</p>	<p>Agilent 13:48:05 Jul 16, 2010</p> <p>Ref 21 dBm #Atten 20 dB Mkr2 Δ 15.750 MHz -0.185 dB</p> <p>Center 2.412 GHz Span 30 MHz</p> <table border="1"> <thead> <tr> <th>Marker</th> <th>Trace</th> <th>Type</th> <th>X Axis</th> <th>Amplitude</th> </tr> </thead> <tbody> <tr> <td>1</td> <td>(1)</td> <td>Freq</td> <td>2.414475 GHz</td> <td>1.866 dBm</td> </tr> <tr> <td>2R</td> <td>(1)</td> <td>Freq</td> <td>2.404350 GHz</td> <td>-4.213 dBm</td> </tr> <tr> <td>2Δ</td> <td>(1)</td> <td>Freq</td> <td>15.750 MHz</td> <td>-0.185 dB</td> </tr> </tbody> </table>	Marker	Trace	Type	X Axis	Amplitude	1	(1)	Freq	2.414475 GHz	1.866 dBm	2R	(1)	Freq	2.404350 GHz	-4.213 dBm	2Δ	(1)	Freq	15.750 MHz	-0.185 dB
Marker	Trace	Type	X Axis	Amplitude																	
1	(1)	Freq	2.414475 GHz	1.866 dBm																	
2R	(1)	Freq	2.404350 GHz	-4.213 dBm																	
2Δ	(1)	Freq	15.750 MHz	-0.185 dB																	
<p>2437</p>	<p>Agilent 13:49:34 Jul 16, 2010</p> <p>Ref 21 dBm #Atten 20 dB Mkr2 Δ 16.200 MHz 0.813 dB</p> <p>Center 2.437 GHz Span 30 MHz</p> <table border="1"> <thead> <tr> <th>Marker</th> <th>Trace</th> <th>Type</th> <th>X Axis</th> <th>Amplitude</th> </tr> </thead> <tbody> <tr> <td>1</td> <td>(1)</td> <td>Freq</td> <td>2.439475 GHz</td> <td>2.195 dBm</td> </tr> <tr> <td>2R</td> <td>(1)</td> <td>Freq</td> <td>2.428825 GHz</td> <td>-4.053 dBm</td> </tr> <tr> <td>2Δ</td> <td>(1)</td> <td>Freq</td> <td>16.200 MHz</td> <td>0.813 dB</td> </tr> </tbody> </table>	Marker	Trace	Type	X Axis	Amplitude	1	(1)	Freq	2.439475 GHz	2.195 dBm	2R	(1)	Freq	2.428825 GHz	-4.053 dBm	2Δ	(1)	Freq	16.200 MHz	0.813 dB
Marker	Trace	Type	X Axis	Amplitude																	
1	(1)	Freq	2.439475 GHz	2.195 dBm																	
2R	(1)	Freq	2.428825 GHz	-4.053 dBm																	
2Δ	(1)	Freq	16.200 MHz	0.813 dB																	
<p>2462</p>	<p>Agilent 13:53:34 Jul 16, 2010</p> <p>Ref 21 dBm #Atten 20 dB Mkr2 Δ 15.675 MHz -0.085 dB</p> <p>Center 2.462 GHz Span 30 MHz</p> <table border="1"> <thead> <tr> <th>Marker</th> <th>Trace</th> <th>Type</th> <th>X Axis</th> <th>Amplitude</th> </tr> </thead> <tbody> <tr> <td>1</td> <td>(1)</td> <td>Freq</td> <td>2.464475 GHz</td> <td>2.15 dBm</td> </tr> <tr> <td>2R</td> <td>(1)</td> <td>Freq</td> <td>2.454200 GHz</td> <td>-4.409 dBm</td> </tr> <tr> <td>2Δ</td> <td>(1)</td> <td>Freq</td> <td>15.675 MHz</td> <td>-0.085 dB</td> </tr> </tbody> </table>	Marker	Trace	Type	X Axis	Amplitude	1	(1)	Freq	2.464475 GHz	2.15 dBm	2R	(1)	Freq	2.454200 GHz	-4.409 dBm	2Δ	(1)	Freq	15.675 MHz	-0.085 dB
Marker	Trace	Type	X Axis	Amplitude																	
1	(1)	Freq	2.464475 GHz	2.15 dBm																	
2R	(1)	Freq	2.454200 GHz	-4.409 dBm																	
2Δ	(1)	Freq	15.675 MHz	-0.085 dB																	

8 Maximum Power Density Measurement

8.1. Limit

For digitally modulated systems, the power spectral density conducted from the intentional radiator to the antenna shall not be greater than 8 dBm in any 3 kHz band during any time interval of continuous transmission.

8.2. Test Setup

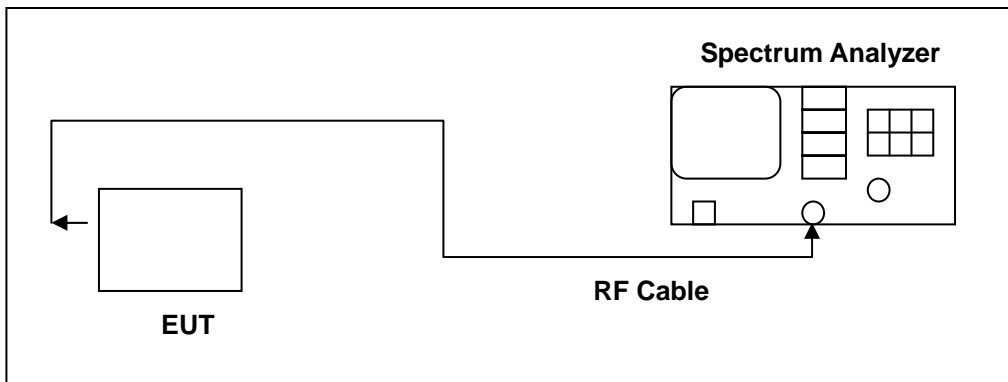

8.3. Test Instruments

Equipment	Manufacturer	Model Number	Serial Number	Cal. Date	Remark
Spectrum Analyzer	Agilent	E4445A	MY46181986	05/14/2009	(2)
Test Site	ATL	TE06	TE06	N.C.R.	-----

Remark: ⁽¹⁾ Calibration period 1 year. ⁽²⁾ Calibration period 2 years.

NOTE: N.C.R. = No Calibration Request.

8.4. Test Procedure

The EUT was setup to ANSI C63.4, 2003; tested to DTS test procedure of Oct 2002 KDB558074 for compliance to FCC 47CFR 15.247 requirements.

The spectrum analyzer RES BW was set to 3 kHz. The START and STOP frequencies were set to the band edges of the maximum output pass band. If there is no clear maximum amplitude in any given portion of the band, it may be necessary to make measurements at a number of bands defined by several START and STOP frequency pairs. The specification calls for a 1 second interval at each 3 kHz bandwidth; total SWEEP TIME is calculated as follows:

$$\text{SWEEP TIME (SEC)} = (\text{Fstop, kHz} - \text{Fstart, kHz}) / 3 \text{ kHz}$$

Antenna output of the EUT was coupled directly to spectrum analyzer; if an external attenuator and/or cable was used, these losses are compensated for with the analyzer OFFSET function.

8.5. Test Result

Model	CT-5367		
Test Item	Maximum Power Density		
Test Mode	Mode 2: IEEE 802.11b Link Mode		
Date of Test	07/16/2010	Test Site	TE06
Frequency (MHz)	Measurement (dBm)	Limit (dBm)	
2412	-8.810	< 8	
2437	-9.923	< 8	
2462	-10.110	< 8	

Model	CT-5367		
Test Item	Maximum Power Density		
Test Mode	Mode 3: IEEE 802.11g Link Mode		
Date of Test	07/16/2010	Test Site	TE06
Frequency (MHz)	Measurement (dBm)	Limit (dBm)	
2412	-13.560	< 8	
2437	-12.770	< 8	
2462	-13.390	< 8	

8.6. Test Graphs

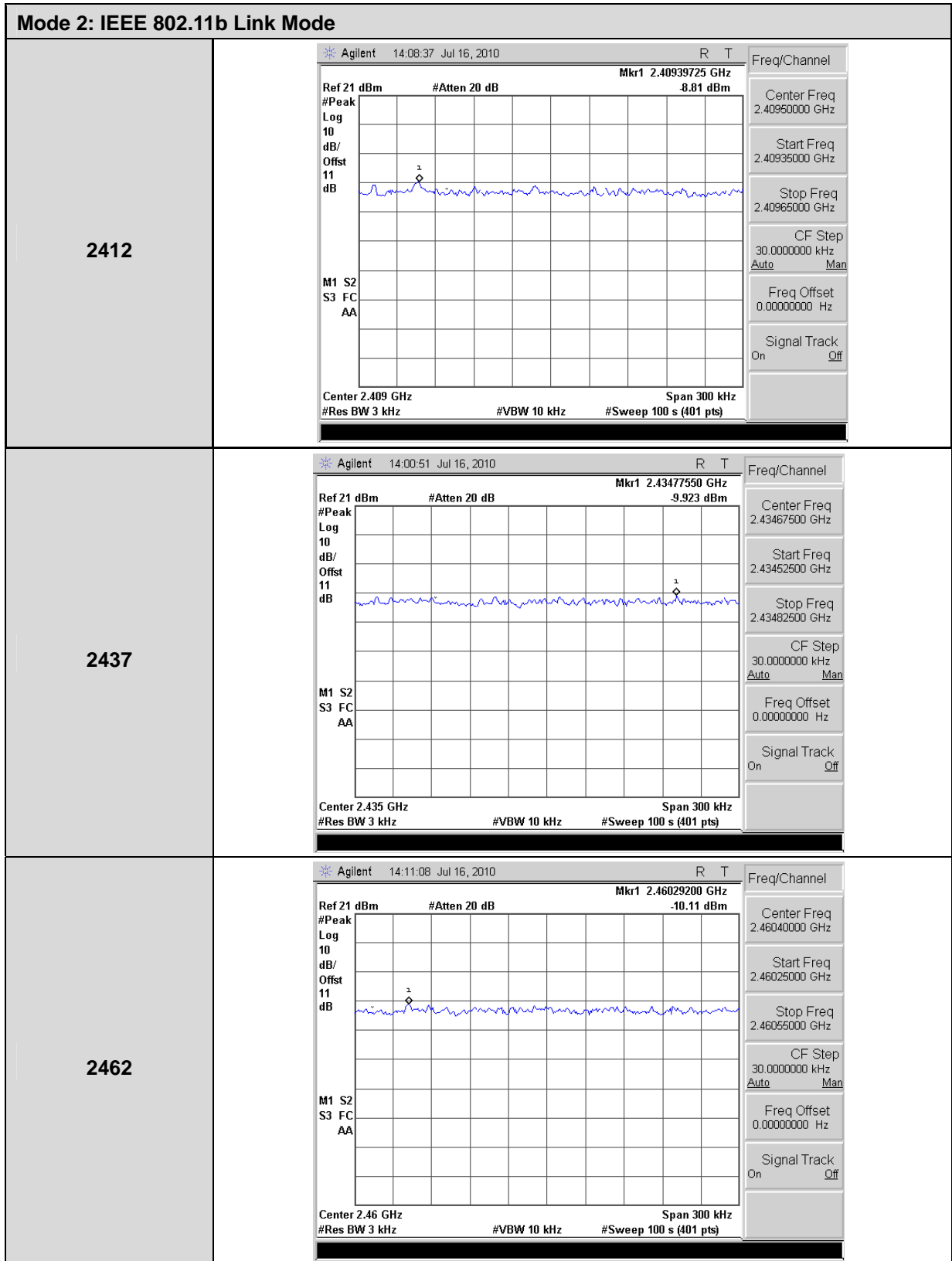

Mode 3: IEEE 802.11g Link Mode	
2412	<p>Agilent 14:05:48 Jul 16, 2010 R T</p> <p>Ref 21 dBm #Atten 20 dB Mkr1 2.41816725 GHz -13.56 dBm</p> <p>#Peak Log 10 dB/Offst 11 dB</p> <p>M1 S2 S3 FC AA</p> <p>Center 2.418 GHz Span 300 kHz #Res BW 3 kHz #VBW 10 kHz #Sweep 100 s (401 pts)</p> <p>Freq/Channel: Center Freq 2.41815000 GHz, Start Freq 2.41800000 GHz, Stop Freq 2.41830000 GHz, CF Step 30.00000000 kHz, Freq Offset 0.00000000 Hz, Signal Track Off</p>
2437	<p>Agilent 14:03:25 Jul 16, 2010 R T</p> <p>Ref 21 dBm #Atten 20 dB Mkr1 2.44316500 GHz -12.77 dBm</p> <p>#Peak Log 10 dB/Offst 11 dB</p> <p>M1 S2 S3 FC AA</p> <p>Center 2.443 GHz Span 300 kHz #Res BW 3 kHz #VBW 10 kHz #Sweep 100 s (401 pts)</p> <p>Freq/Channel: Center Freq 2.44315000 GHz, Start Freq 2.44300000 GHz, Stop Freq 2.44330000 GHz, CF Step 30.00000000 kHz, Freq Offset 0.00000000 Hz, Signal Track Off</p>
2462	<p>Agilent 14:13:50 Jul 16, 2010 R T</p> <p>Ref 21 dBm #Atten 20 dB Mkr1 2.45691800 GHz -13.39 dBm</p> <p>#Peak Log 10 dB/Offst 11 dB</p> <p>M1 S2 S3 FC AA</p> <p>Center 2.457 GHz Span 300 kHz #Res BW 3 kHz #VBW 10 kHz #Sweep 100 s (401 pts)</p> <p>Freq/Channel: Center Freq 2.45690000 GHz, Start Freq 2.45675000 GHz, Stop Freq 2.45705000 GHz, CF Step 30.00000000 kHz, Freq Offset 0.00000000 Hz, Signal Track Off</p>

9 Out of Band Conducted Emissions Measurement

9.1. Limit

In any 100 kHz bandwidth outside the frequency band in which the spread spectrum or digitally modulated intentional radiator is operating, the radio frequency power that is produced by the intentional radiator shall be at least 20 dB below that in the 100 kHz bandwidth within the band that contains the highest level of the desired power

9.2. Test Setup

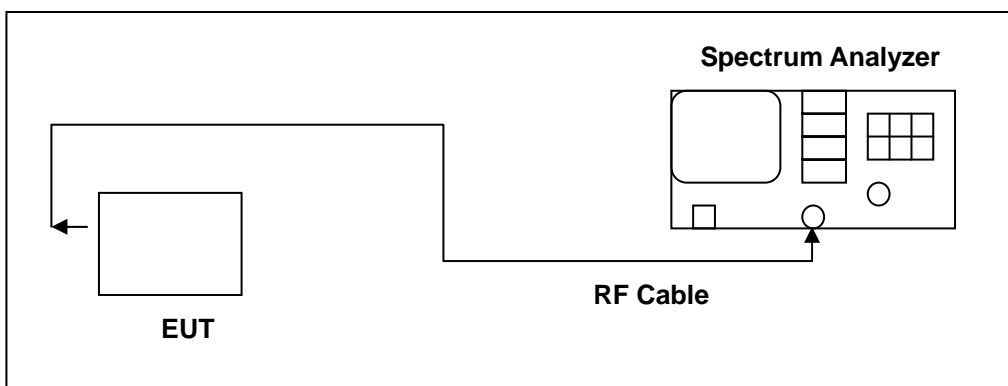

9.3. Test Instruments

Equipment	Manufacturer	Model Number	Serial Number	Cal. Date	Remark
Spectrum Analyzer	Agilent	E4445A	MY46181986	05/14/2009	⁽²⁾
Test Site	ATL	TE06	TE06	N.C.R.	-----

Remark: ⁽¹⁾ Calibration period 1 year. ⁽²⁾ Calibration period 2 years.

NOTE: N.C.R. = No Calibration Request.

9.4. Test Procedure

In any 100 kHz bandwidth outside the EUT pass band, the RF power produced by the modulation products of the spreading sequence, the information sequence, and the carrier frequency shall be at least 20 dB below that of the maximum in-band 100 kHz emission, antenna output of the EUT was coupled directly to spectrum analyzer; if an external attenuator and/or cable was used, these losses are compensated for with the analyzer OFFSET function.

All other types of emissions from the EUT shall meet the general limits for radiated frequencies outside the pass band. The test was performed at 3 channels (Channel 1, 6, 11)

9.5. Test Graphs

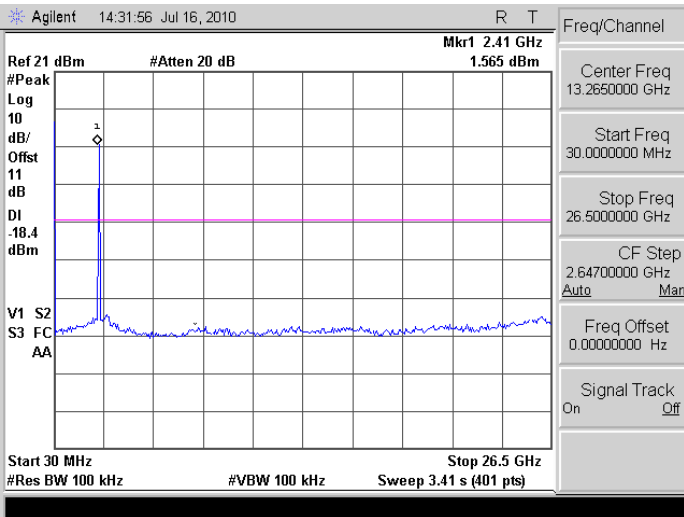
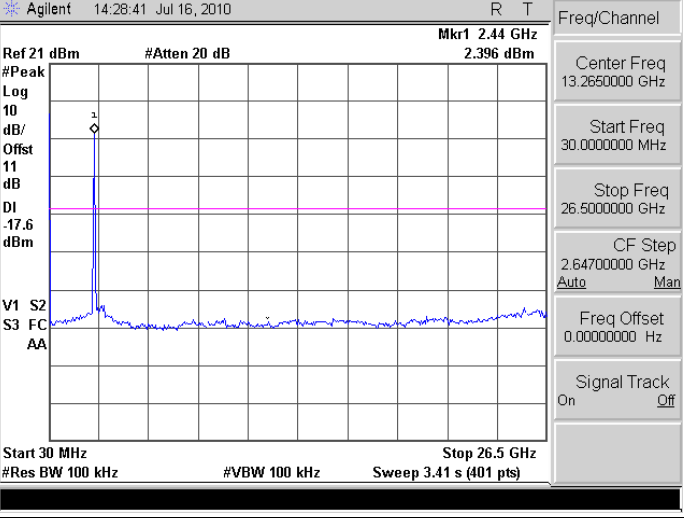
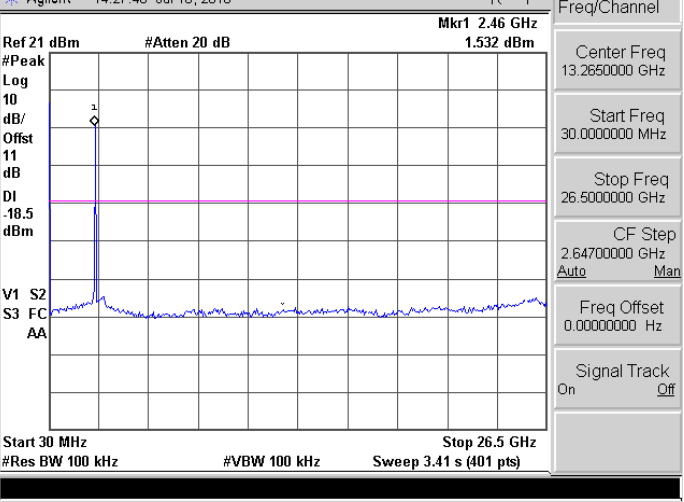
Mode 2: IEEE 802.11b Link Mode	
2412	 <p>Agilent 14:31:56 Jul 16, 2010 R T</p> <p>Ref 21 dBm #Atten 20 dB Mkr1 2.41 GHz 1.565 dBm</p> <p>#Peak Log 10 dB/Offst 11 dB DI -18.4 dBm</p> <p>V1 S2 S3 FC AA</p> <p>Start 30 MHz #Res BW 100 kHz #VBW 100 kHz Stop 26.5 GHz Sweep 3.41 s (401 pts)</p> <p>Freq/Channel: Center Freq 13.2650000 GHz, Start Freq 30.0000000 MHz, Stop Freq 26.5000000 GHz, CF Step 2.64700000 GHz, Freq Offset 0.00000000 Hz, Signal Track On</p>
2437	 <p>Agilent 14:28:41 Jul 16, 2010 R T</p> <p>Ref 21 dBm #Atten 20 dB Mkr1 2.44 GHz 2.396 dBm</p> <p>#Peak Log 10 dB/Offst 11 dB DI -17.6 dBm</p> <p>V1 S2 S3 FC AA</p> <p>Start 30 MHz #Res BW 100 kHz #VBW 100 kHz Stop 26.5 GHz Sweep 3.41 s (401 pts)</p> <p>Freq/Channel: Center Freq 13.2650000 GHz, Start Freq 30.0000000 MHz, Stop Freq 26.5000000 GHz, CF Step 2.64700000 GHz, Freq Offset 0.00000000 Hz, Signal Track On</p>
2462	 <p>Agilent 14:27:40 Jul 16, 2010 R T</p> <p>Ref 21 dBm #Atten 20 dB Mkr1 2.46 GHz 1.532 dBm</p> <p>#Peak Log 10 dB/Offst 11 dB DI -18.5 dBm</p> <p>V1 S2 S3 FC AA</p> <p>Start 30 MHz #Res BW 100 kHz #VBW 100 kHz Stop 26.5 GHz Sweep 3.41 s (401 pts)</p> <p>Freq/Channel: Center Freq 13.2650000 GHz, Start Freq 30.0000000 MHz, Stop Freq 26.5000000 GHz, CF Step 2.64700000 GHz, Freq Offset 0.00000000 Hz, Signal Track On</p>

Mode 3: IEEE 802.11g Link Mode

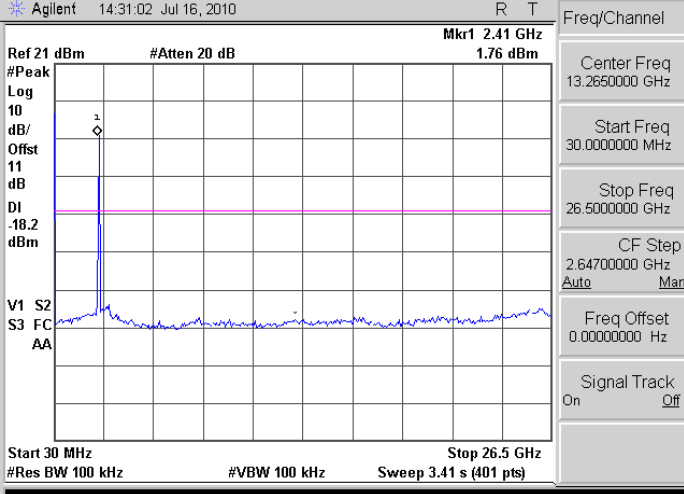
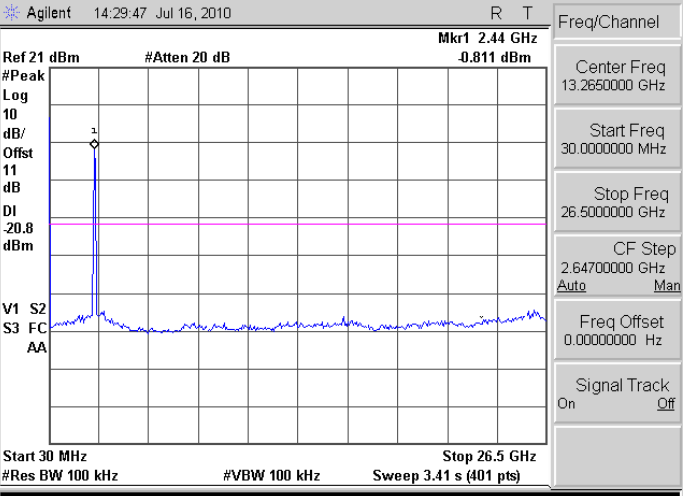
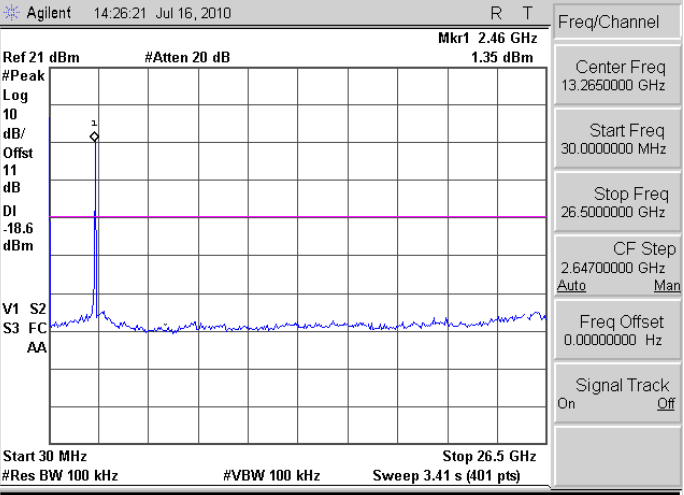
<p>2412</p>	
<p>2437</p>	
<p>2462</p>	

10 Band Edges Measurement

10.1. Limit

In any 100 kHz bandwidth outside the intentional radiation frequency band, the radio frequency power shall be at least 20 dB below the highest level of the radiated power. In addition, radiated emissions which fall in the restricted bands must also comply with the radiated emission limits.

10.2. Test Setup

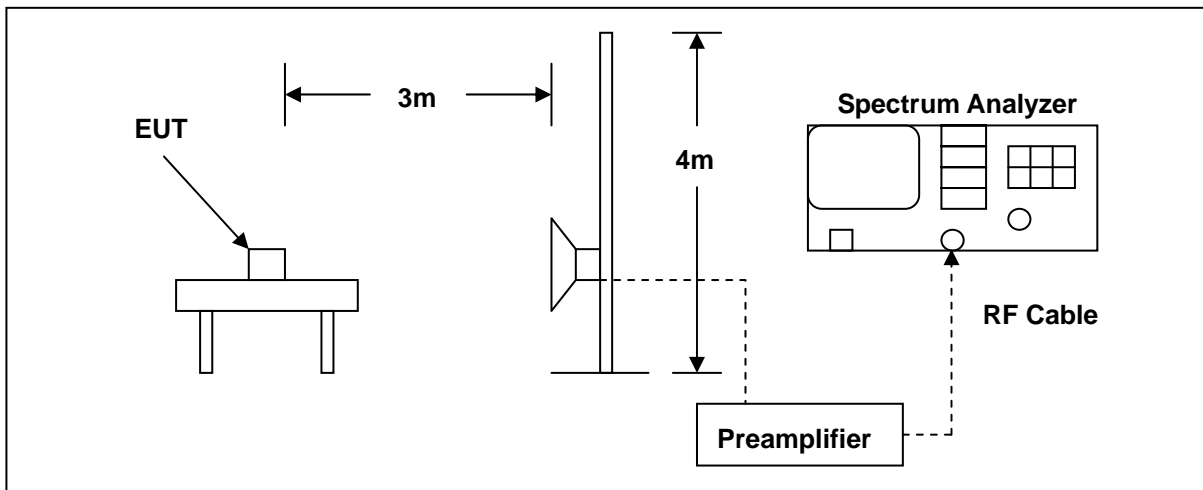

10.3. Test Instruments

Equipment	Manufacturer	Model Number	Serial Number	Cal. Date	Remark
Spectrum Analyzer	Agilent	E4408B	MY45107753	06/23/2009	(2)
Pre Amplifier	Agilent	8449B	3008A02237	02/24/2010	(1)
Horn Antenna	SCHWARZBECK MESS-ELEKTRONIK	9120D	9120D-550	07/01/2009	(2)
Test Site	ATL	TE06	TE06	N.C.R.	-----

Remark: ⁽¹⁾ Calibration period 1 year. ⁽²⁾ Calibration period 2 years.

NOTE: N.C.R. = No Calibration Request.

10.4. Test Procedure

The EUT was setup to ANSI C63.4, 2003; tested to DTS test procedure of Oct 2002 KDB558074 for compliance to FCC 47CFR 15.247 requirements.

The emissions on the harmonics frequencies, the limits, and the margin of compliance are presented. These tests were made when the transmitter was in full radiated power. The additional test was performed to show compliance with the requirement at the band-edge frequency 2483.5 MHz and up to 2500 MHz and at 2390.0 MHz.

The transmitter was configured with the worst case antenna and setup to transmit at the highest channel. Then the field strength was measured at 2483.5 MHz.

The transmitter was then configured with the worst case antenna and setup to transmit at the lowest channel. Then the field strength was measured at 2390.0 MHz. These tests were performed at 4 different bit rates.

10.5. Test Result

Standard:	FCC Part 15C	Test Distance:	3m
Test item:	Radiated Emission	Power:	AC 120V/60Hz
Model:	CT-5367	Temp.(°C)/Hum.(%RH):	26(°C)/60%RH
Mode:	Mode 2	Date:	2010/07/15
Frequency:	2412 MHz	Test By:	Gary Wu
Ant.Polar.:	Horizontal		

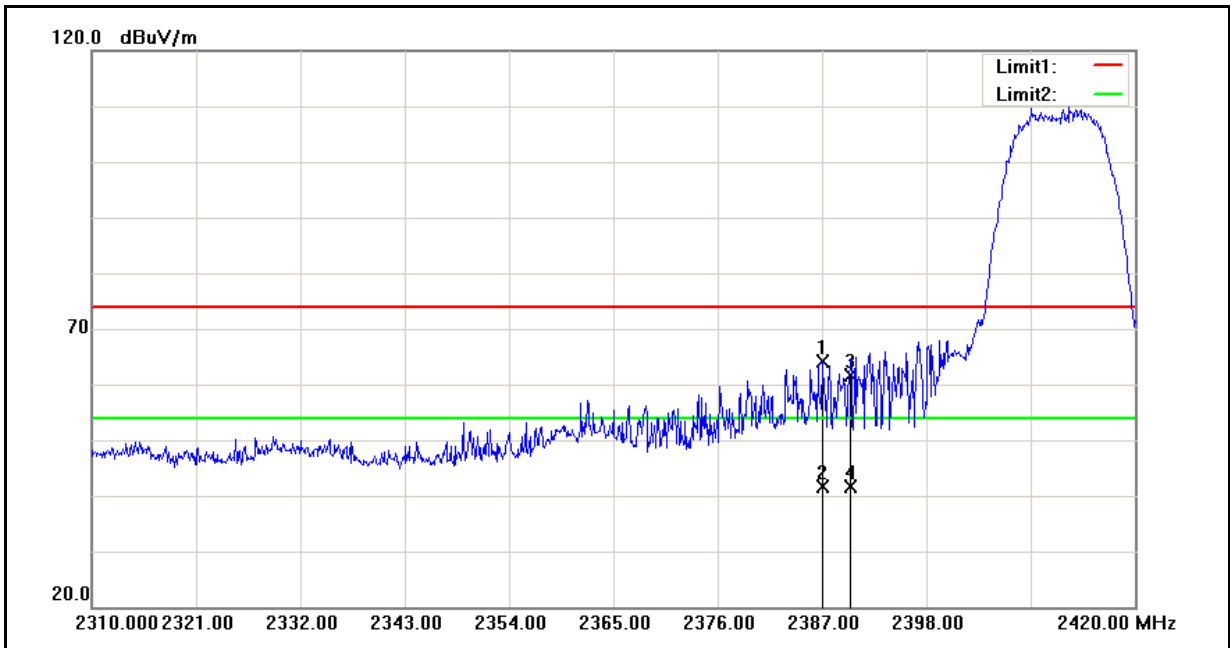

No.	Frequency (MHz)	Reading (dBuV)	Correct Factor(dB/m)	Result (dBuV/m)	Limit (dBuV/m)	Margin (dB)	Remark
1	2387.000	64.36	-0.22	64.14	74.00	-9.86	peak
2	2387.000	41.74	-0.22	41.52	54.00	-12.48	AVG
3	2390.000	61.76	-0.22	61.54	74.00	-12.46	peak
4	2390.000	41.75	-0.22	41.53	54.00	-12.47	AVG

Standard:	FCC Part 15C	Test Distance:	3m
Test item:	Radiated Emission	Power:	AC 120V/60Hz
Model:	CT-5367	Temp.(°C)/Hum.(%RH):	26(°C)/60%RH
Mode:	Mode 2	Date:	2010/7/15
Frequency:	2412 MHz	Test By:	Gary Wu
Ant.Polar.:	Vertical		

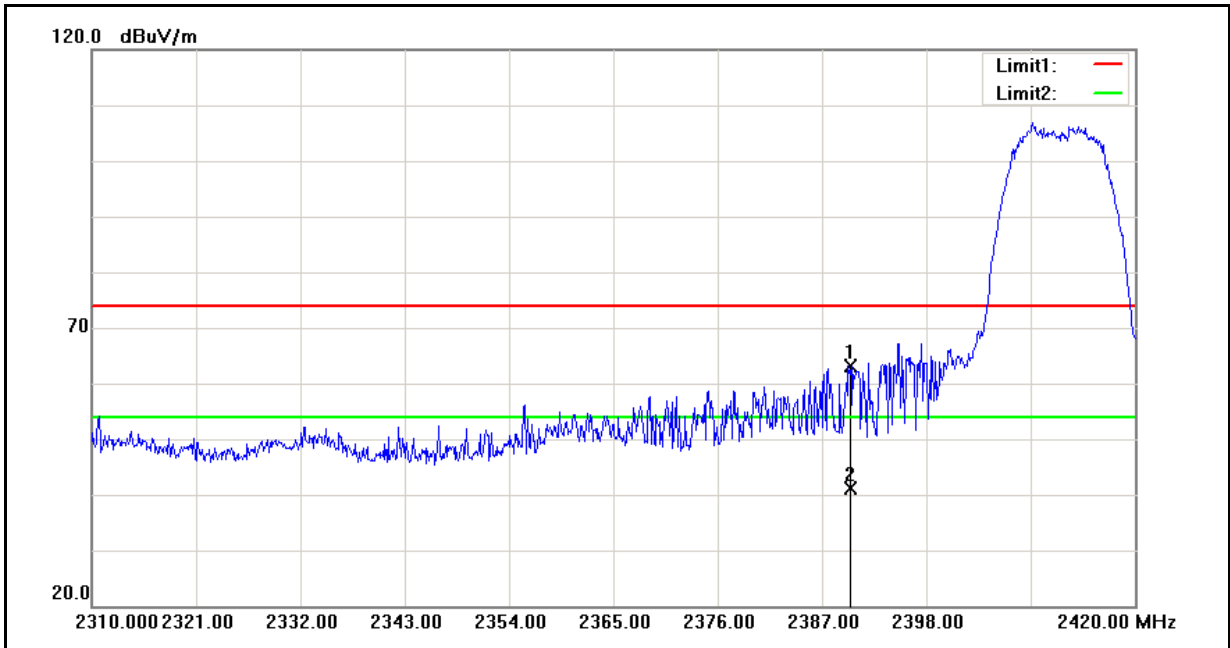

No.	Frequency (MHz)	Reading (dBuV)	Correct Factor(dB/m)	Result (dBuV/m)	Limit (dBuV/m)	Margin (dB)	Remark
1	2390.000	63.40	-0.22	63.18	74.00	-10.82	peak
2	2390.000	41.31	-0.22	41.09	54.00	-12.91	AVG

Standard:	FCC Part 15C	Test Distance:	3m
Test item:	Radiated Emission	Power:	AC 120V/60Hz
Model:	CT-5367	Temp.(°C)/Hum.(%RH):	26(°C)/60%RH
Mode:	Mode 2	Date:	2010/07/15
Frequency:	2462 MHz	Test By:	Gary Wu
Ant.Polar.:	Horizontal		

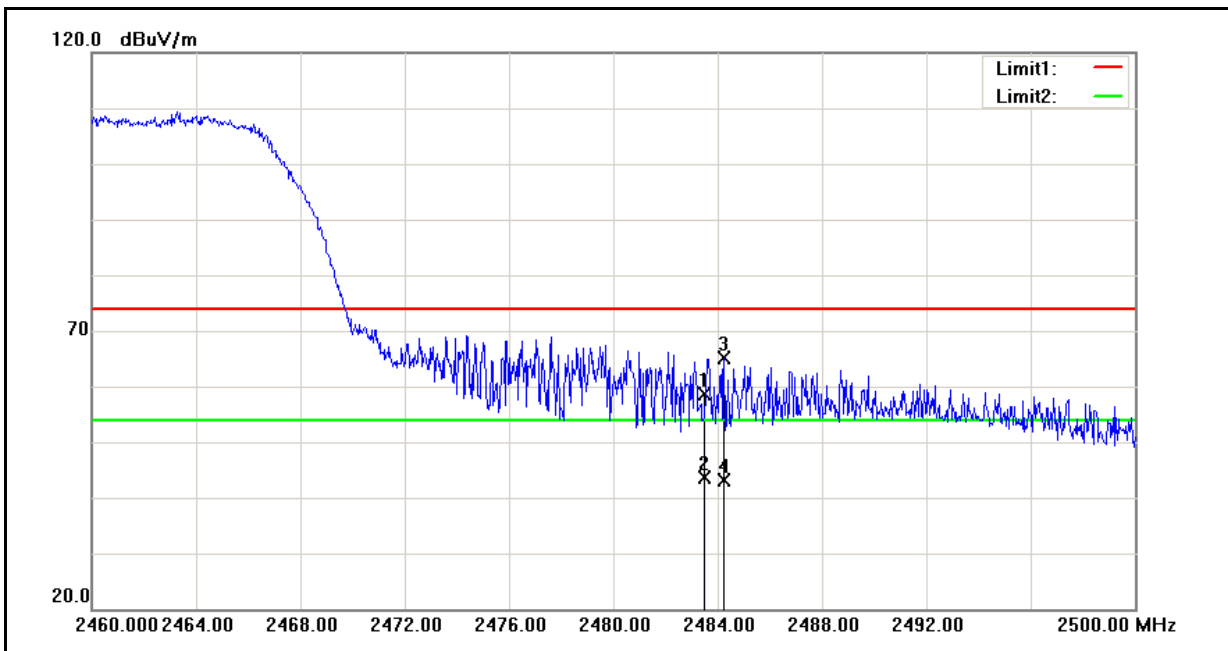

No.	Frequency (MHz)	Reading (dBuV)	Correct Factor(dB/m)	Result (dBuV/m)	Limit (dBuV/m)	Margin (dB)	Remark
1	2483.500	58.52	0.16	58.68	74.00	-15.32	peak
2	2483.500	43.39	0.16	43.55	54.00	-10.45	AVG
3	2484.240	64.87	0.16	65.03	74.00	-8.97	peak
4	2484.240	42.87	0.16	43.03	54.00	-10.97	AVG

Standard:	FCC Part 15C	Test Distance:	3m
Test item:	Radiated Emission	Power:	AC 120V/60Hz
Model:	CT-5367	Temp.(°C)/Hum.(%RH):	26(°C)/60%RH
Mode:	Mode 2	Date:	2010/07/15
Frequency:	2462 MHz	Test By:	Gary Wu
Ant.Polar.:	Vertical		

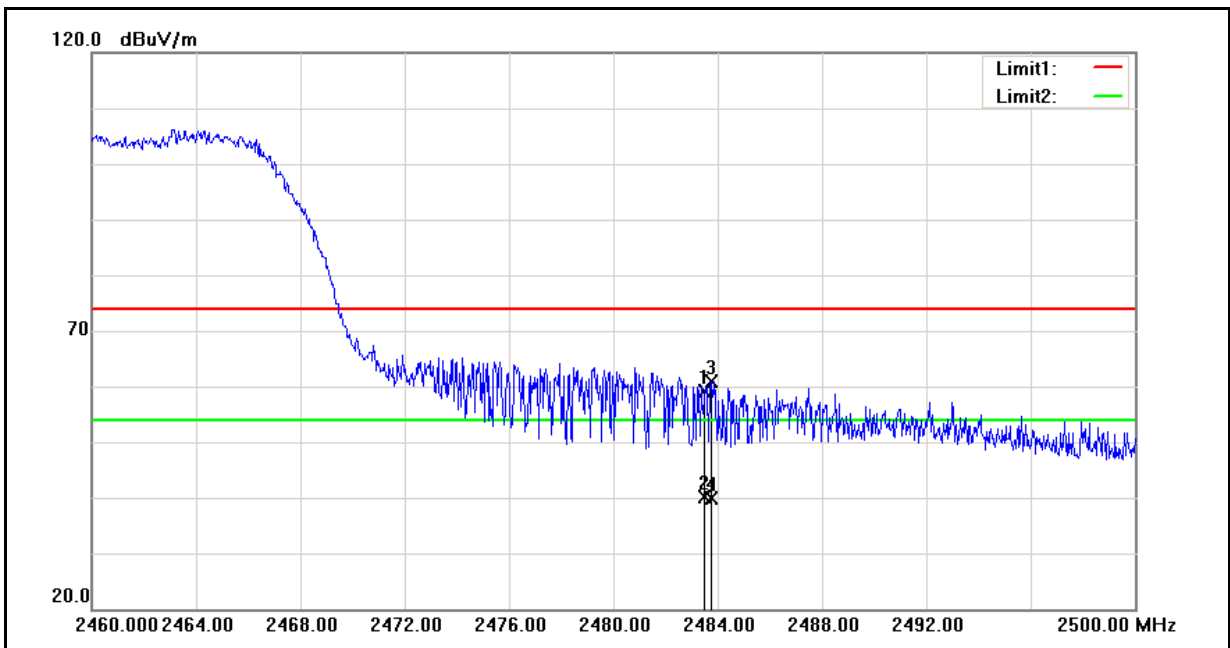

No.	Frequency (MHz)	Reading (dBuV)	Correct Factor(dB/m)	Result (dBuV/m)	Limit (dBuV/m)	Margin (dB)	Remark
1	2483.500	58.86	0.16	59.02	74.00	-14.98	peak
2	2483.500	39.87	0.16	40.03	54.00	-13.97	AVG
3	2483.760	60.72	0.16	60.88	74.00	-13.12	peak
4	2483.760	39.84	0.16	40.00	54.00	-14.00	AVG

Standard:	FCC Part 15C	Test Distance:	3m
Test item:	Radiated Emission	Power:	AC 120V/60Hz
Model:	CT-5367	Temp.(°C)/Hum.(%RH):	26(°C)/60%RH
Mode:	Mode 3	Date:	2010/07/15
Frequency:	2412 MHz	Test By:	Gary Wu
Ant.Polar.:	Horizontal		

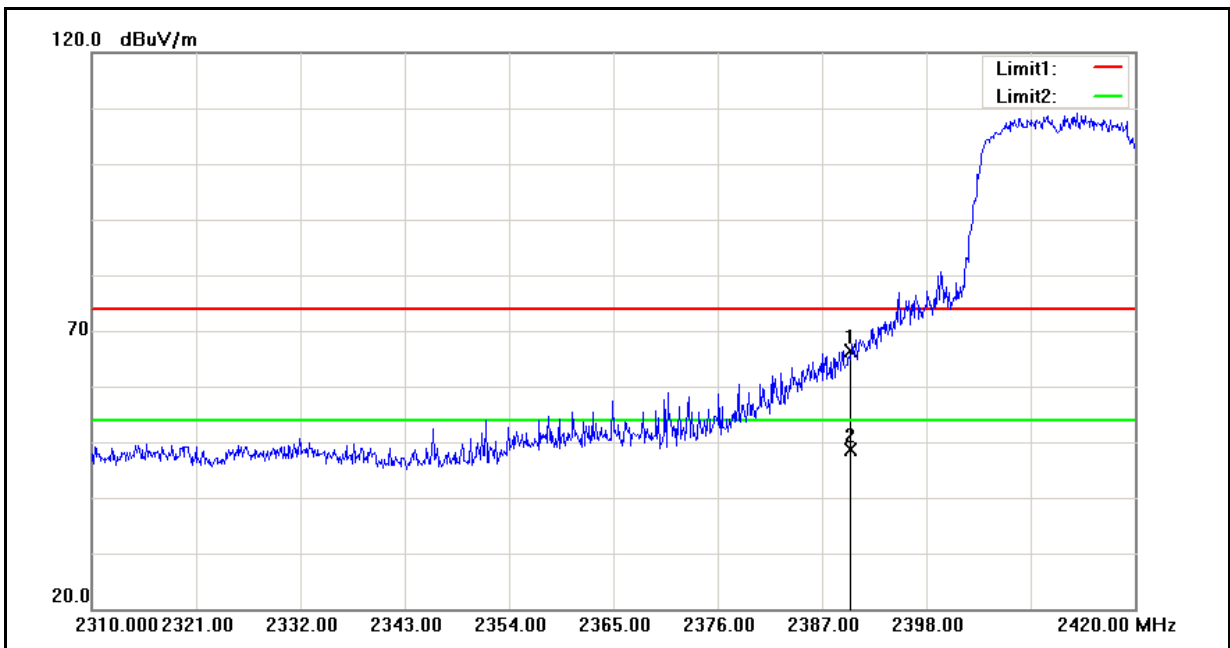

No.	Frequency (MHz)	Reading (dBuV)	Correct Factor(dB/m)	Result (dBuV/m)	Limit (dBuV/m)	Margin (dB)	Remark
1	2390.000	66.69	-0.22	66.47	74.00	-7.53	peak
2	2390.000	48.75	-0.22	48.53	54.00	-5.47	AVG

Standard:	FCC Part 15C	Test Distance:	3m
Test item:	Radiated Emission	Power:	AC 120V/60Hz
Model:	CT-5367	Temp.(°C)/Hum.(%RH):	26(°C)/60%RH
Mode:	Mode 3	Date:	2010/07/15
Frequency:	2412 MHz	Test By:	Gary Wu
Ant.Polar.:	Vertical		

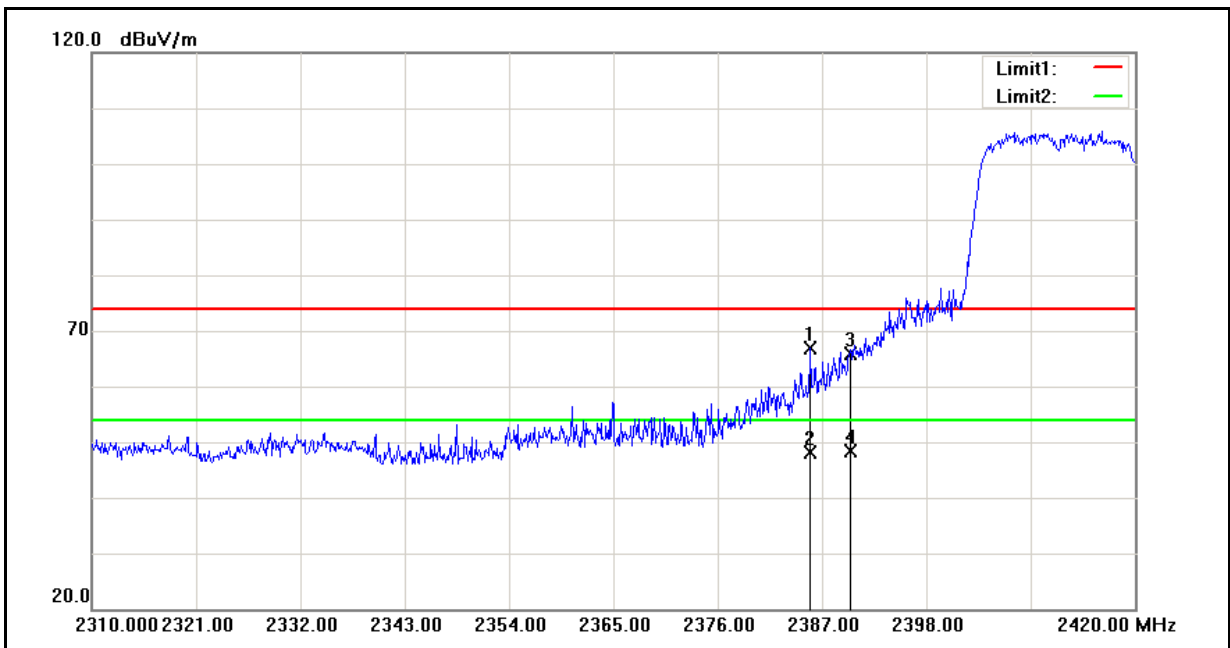

No.	Frequency (MHz)	Reading (dBuV)	Correct Factor(dB/m)	Result (dBuV/m)	Limit (dBuV/m)	Margin (dB)	Remark
1	2385.790	67.02	-0.24	66.78	74.00	-7.22	peak
2	2385.790	48.49	-0.24	48.25	54.00	-5.75	AVG
3	2390.000	66.17	-0.22	65.95	74.00	-8.05	peak
4	2390.000	48.62	-0.22	48.40	54.00	-5.60	AVG

Standard:	FCC Part 15C	Test Distance:	3m
Test item:	Radiated Emission	Power:	AC 120V/60Hz
Model:	CT-5367	Temp.(°C)/Hum.(%RH):	26(°C)/60%RH
Mode:	Mode 3	Date:	2010/07/15
Frequency:	2462 MHz	Test By:	Gary Wu
Ant.Polar.:	Horizontal		

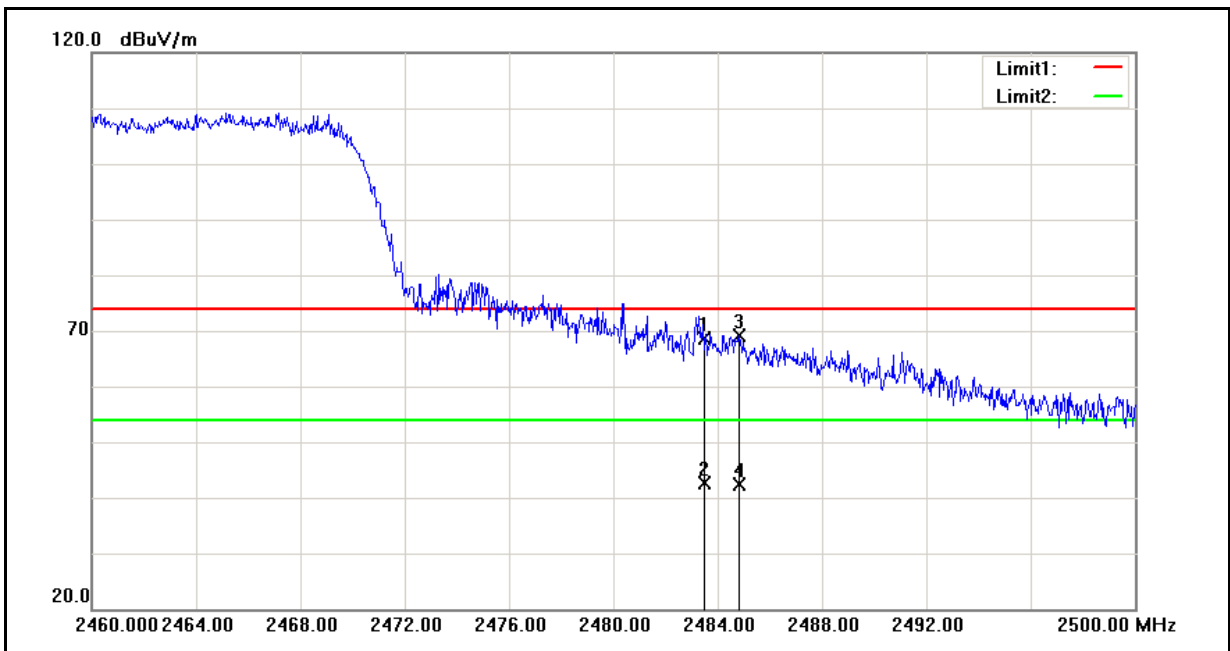

No.	Frequency (MHz)	Reading (dBuV)	Correct Factor(dB/m)	Result (dBuV/m)	Limit (dBuV/m)	Margin (dB)	Remark
1	2483.500	68.59	0.16	68.75	74.00	-5.25	peak
2	2483.500	42.35	0.16	42.51	54.00	-11.49	AVG
3	2484.800	68.98	0.16	69.14	74.00	-4.86	peak
4	2484.800	42.10	0.16	42.26	54.00	-11.74	AVG

Standard:	FCC Part 15C	Test Distance:	3m
Test item:	Radiated Emission	Power:	AC 120V/60Hz
Model:	CT-5367	Temp.(°C)/Hum.(%RH):	26(°C)/60%RH
Mode:	Mode 3	Date:	2010/07/15
Frequency:	2462 MHz	Test By:	Gary Wu
Ant.Polar.:	Vertical		

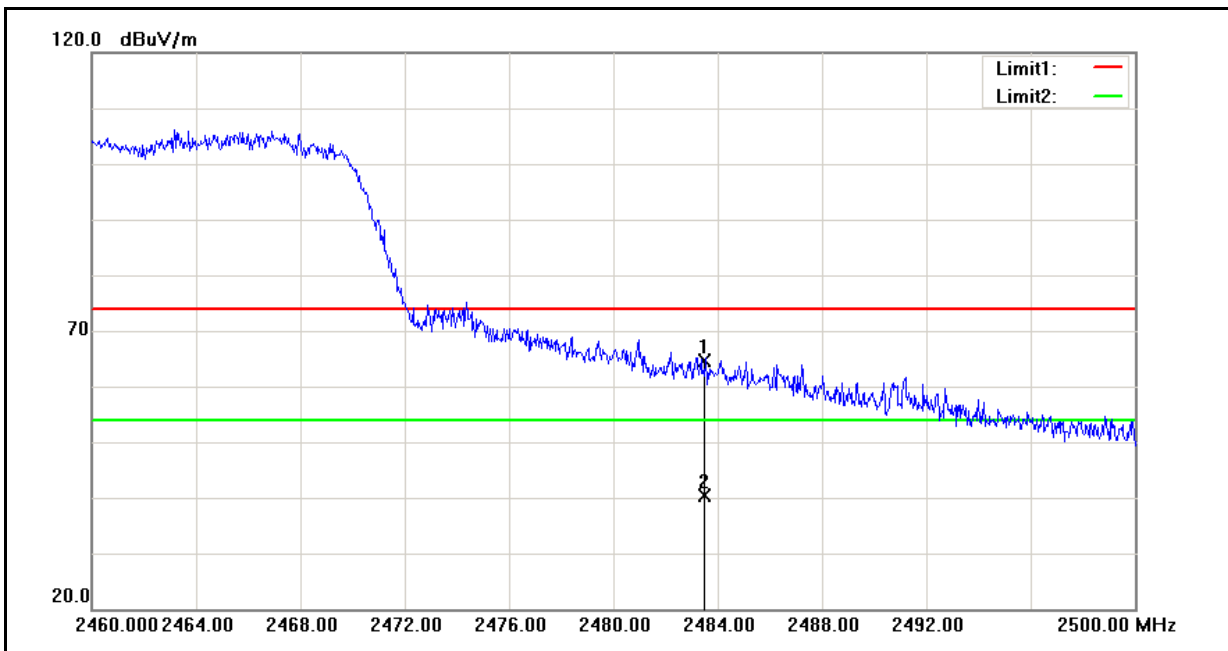

No.	Frequency (MHz)	Reading (dBuV)	Correct Factor(dB/m)	Result (dBuV/m)	Limit (dBuV/m)	Margin (dB)	Remark
1	2483.500	64.48	0.16	64.64	74.00	-9.36	peak
2	2483.500	40.21	0.16	40.37	54.00	-13.63	AVG

11 99 % Occupied Bandwidth Measurement

11.1. Limit

N/A

11.2. Test Setup

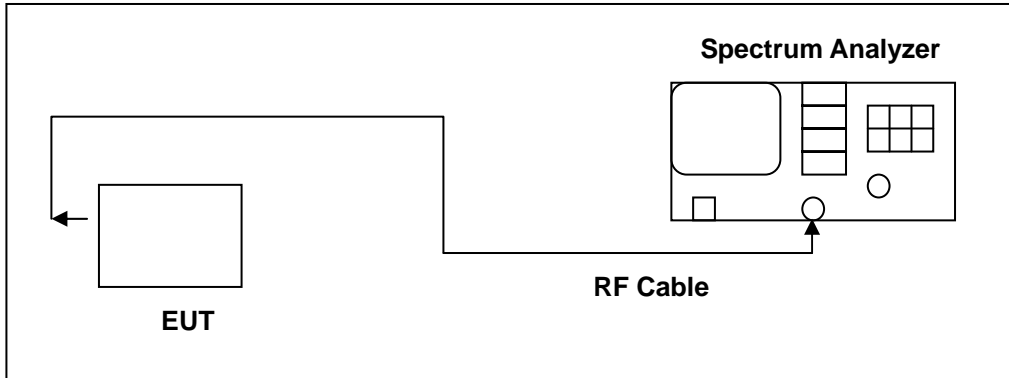

11.3. Test Instruments

Equipment	Manufacturer	Model Number	Serial Number	Cal. Date	Remark
Spectrum Analyzer	Agilent	E4445A	MY46181986	05/14/2009	(2)
Test Site	ATL	TE06	TE06	N.C.R.	-----

Remark: ⁽¹⁾ Calibration period 1 year. ⁽²⁾ Calibration period 2 years.

NOTE: N.C.R. = No Calibration Request.

11.4. Test Procedure

The transmitter output is connected to the spectrum analyzer. The RBW is set to 1% to 3% of the 99 % bandwidth. The VBW is set to 3 times the RBW. The sweep time is coupled.

11.5. Test Result

Model	CT-5367		
Test Item	99 % Occupied Bandwidth		
Test Mode	Mode 2: IEEE 802.11b Link Mode		
Date of Test	07/16/2010	Test Site	TE06
Frequency (MHz)	Measurement (kHz)		Limit (kHz)
2412	11301.7		-----
2437	11232.0		-----
2462	11219.4		-----

Model	07/16/2010		
Test Item	99 % Occupied Bandwidth		
Test Mode	Mode 3: IEEE 802.11g Link Mode		
Date of Test	07/16/2010	Test Site	TE06
Frequency (MHz)	Measurement (kHz)		Limit (kHz)
2412	16511.4		-----
2437	16459.6		-----
2462	16435.9		-----

11.6. Test Graphs

Mode 2: IEEE 802.11b Link Mode	
2412	<p>Agilent 13:56:05 Jul 16, 2010 R T</p> <p>Ch Freq 2.412 GHz Trig Free</p> <p>Occupied Bandwidth</p> <p>Ref 21 dBm #Atten 20 dB</p> <p>#Peak Log 10 dB/ Offst 11 dB</p> <p>Center 2.412 GHz Span 50 MHz #Res BW 300 kHz #VBW 1 MHz Sweep 4 ms (401 pts)</p> <p>Occupied Bandwidth 11.3017 MHz Occ BW % Pwr 99.00 % x dB -26.00 dB</p> <p>Transmit Freq Error -3.727 kHz x dB Bandwidth 13.865 MHz</p> <p>Freq/Channel: Center Freq 2.4120000 GHz, Start Freq 2.3870000 GHz, Stop Freq 2.4370000 GHz, CF Step 5.0000000 MHz (Auto/Man), Freq Offset 0.0000000 Hz, Signal Track On (Off)</p>
2437	<p>Agilent 13:57:47 Jul 16, 2010 R T</p> <p>Ch Freq 2.437 GHz Trig Free</p> <p>Occupied Bandwidth</p> <p>Ref 21 dBm #Atten 20 dB</p> <p>#Peak Log 10 dB/ Offst 11 dB</p> <p>Center 2.437 GHz Span 50 MHz #Res BW 300 kHz #VBW 1 MHz Sweep 4 ms (401 pts)</p> <p>Occupied Bandwidth 11.2320 MHz Occ BW % Pwr 99.00 % x dB -26.00 dB</p> <p>Transmit Freq Error -20.813 kHz x dB Bandwidth 13.921 MHz</p> <p>Freq/Channel: Center Freq 2.4370000 GHz, Start Freq 2.4120000 GHz, Stop Freq 2.4620000 GHz, CF Step 5.0000000 MHz (Auto/Man), Freq Offset 0.0000000 Hz, Signal Track On (Off)</p>
2462	<p>Agilent 13:55:31 Jul 16, 2010 R T</p> <p>Ch Freq 2.462 GHz Trig Free</p> <p>Occupied Bandwidth</p> <p>Ref 21 dBm #Atten 20 dB</p> <p>#Peak Log 10 dB/ Offst 11 dB</p> <p>Center 2.462 GHz Span 50 MHz #Res BW 300 kHz #VBW 1 MHz Sweep 4 ms (401 pts)</p> <p>Occupied Bandwidth 11.2194 MHz Occ BW % Pwr 99.00 % x dB -26.00 dB</p> <p>Transmit Freq Error -20.447 kHz x dB Bandwidth 13.869 MHz</p> <p>Freq/Channel: Center Freq 2.4620000 GHz, Start Freq 2.4370000 GHz, Stop Freq 2.4870000 GHz, CF Step 5.0000000 MHz (Auto/Man), Freq Offset 0.0000000 Hz, Signal Track On (Off)</p>

Mode 3: IEEE 802.11g Link Mode	
2412	<p>Agilent 13:56:43 Jul 16, 2010 R T</p> <p>Ch Freq 2.412 GHz Trig Free</p> <p>Occupied Bandwidth</p> <p>Ref 21 dBm #Atten 20 dB</p> <p>#Peak Log 10 dB/Offst 11 dB</p> <p>Center 2.412 GHz Span 50 MHz #Res BW 300 kHz #VBW 1 MHz Sweep 4 ms (401 pts)</p> <p>Occupied Bandwidth Occ BW % Pwr 99.00 % 16.5114 MHz x dB -26.00 dB</p> <p>Transmit Freq Error -11.193 kHz x dB Bandwidth 22.369 MHz</p> <p>Freq/Channel Center Freq 2.41200000 GHz Start Freq 2.38700000 GHz Stop Freq 2.43700000 GHz CF Step 5.00000000 MHz Auto Man Freq Offset 0.00000000 Hz Signal Track On Off</p>
2437	<p>Agilent 13:57:12 Jul 16, 2010 R T</p> <p>Ch Freq 2.437 GHz Trig Free</p> <p>Occupied Bandwidth</p> <p>Ref 21 dBm #Atten 20 dB</p> <p>#Peak Log 10 dB/Offst 11 dB</p> <p>Center 2.437 GHz Span 50 MHz #Res BW 300 kHz #VBW 1 MHz Sweep 4 ms (401 pts)</p> <p>Occupied Bandwidth Occ BW % Pwr 99.00 % 16.4596 MHz x dB -26.00 dB</p> <p>Transmit Freq Error -22.180 kHz x dB Bandwidth 20.497 MHz</p> <p>Freq/Channel Center Freq 2.43700000 GHz Start Freq 2.41200000 GHz Stop Freq 2.46200000 GHz CF Step 5.00000000 MHz Auto Man Freq Offset 0.00000000 Hz Signal Track On Off</p>
2462	<p>Agilent 13:54:39 Jul 16, 2010 R T</p> <p>Ch Freq 2.462 GHz Trig Free</p> <p>Occupied Bandwidth</p> <p>Ref 21 dBm #Atten 20 dB</p> <p>#Peak Log 10 dB/Offst 11 dB</p> <p>Center 2.462 GHz Span 50 MHz #Res BW 300 kHz #VBW 1 MHz Sweep 4 ms (401 pts)</p> <p>Occupied Bandwidth Occ BW % Pwr 99.00 % 16.4359 MHz x dB -26.00 dB</p> <p>Transmit Freq Error -48.207 kHz x dB Bandwidth 19.082 MHz</p> <p>Freq/Channel Center Freq 2.46200000 GHz Start Freq 2.43700000 GHz Stop Freq 2.48700000 GHz CF Step 5.00000000 MHz Auto Man Freq Offset 0.00000000 Hz Signal Track On Off</p>

12 Antenna Measurement

12.1. Limit

For intentional device, according to 15.203, an intentional radiator shall be designed to ensure that no antenna other than that furnished by the responsible party shall be used with the device.

And According to 15.247 (b), if transmitting antennas of directional gain greater than 6 dBi are used, the power shall be reduced by the amount in dB that the directional gain of the antenna exceeds 6dBi.

12.2. Antenna Connector Construction

The antenna used in this product is **External antenna**. And the maximum Gain of this antenna is only **2 dBi**.