

## **3. CIRCUIT DESCRIPTION**

### **TRANSMITTER**

The transmitter is comprised of:

- Audio amplifier connections from J501 pin 1
- Frequency Synthesiser
- Transmitter
- Automatic Power Control

### **Audio frequency connections**

Processed data from the IC504 is applied to the VCO via P305 and applied to the TCXO P701

### **Frequency synthesiser circuit**

With data received from the EEPROM (IC502) the frequency synthesiser circuit controls and Produces the RF carrier frequency for the transmitter during transmit and the local oscillator frequency for the receiver. The frequency synthesiser circuit is comprised of:

- 12.8 MHZ Texo
- Voltage Controlled Oscillator (VCO) module
- Charge Pump and Loop Filter
- PLL Frequency Synthesiser
- Dual Modulus Prescaler

## PLL Synthesiser

The PLL synthesiser circuit is common to both the transmitter and receiver,

The synthesiser comprises:

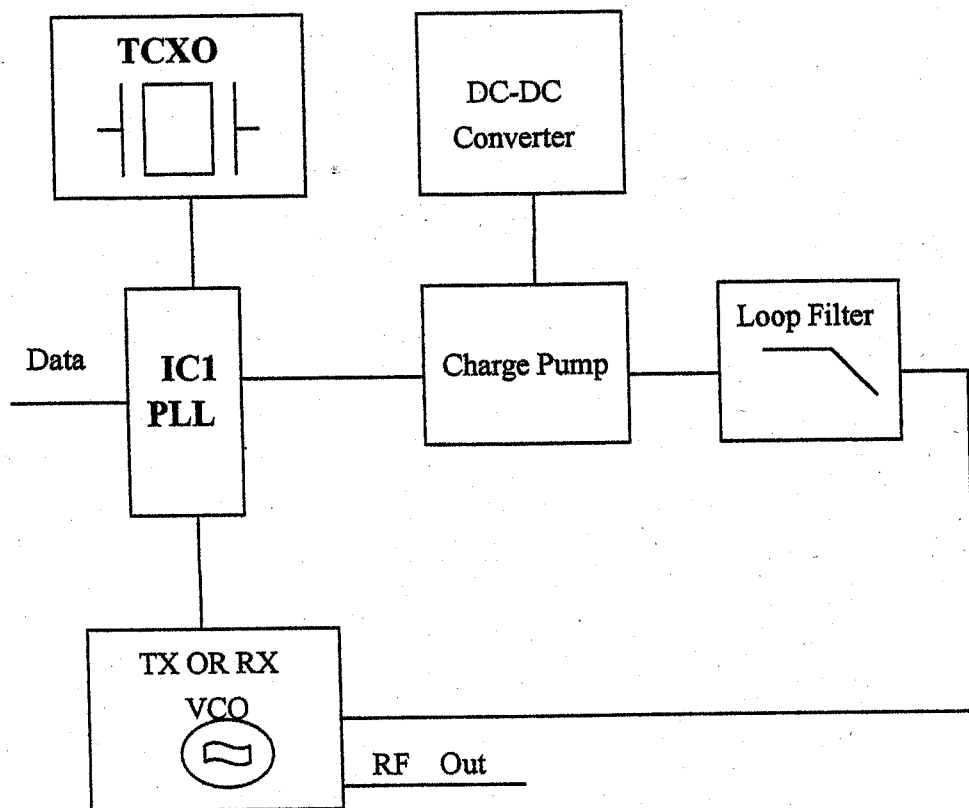

### 12.8 MHz TCXO

The reference oscillator module comprises Q701, Q702, D700, D701, X700 (12.8 MHz) TH700-702 and associated resistors and capacitors.

D700, D701, X700 and Q701 form a Colpitts oscillator. D700 along with TH700-703 provides the temperature compensation that ensures that the frequency remains stable across the temperature range (typically  $\pm 2.5$  ppm). D701 is the modulation port for the two port modulation system used in the DATARADIO range of radios and is DC coupled. Q702 buffers the reference oscillator signal before passing it to the PLL synthesiser IC1.

Frequency adjustment is provided by VC700

### .Voltage controlled oscillator module(VCO)

The module produces carrier frequencies during transmit and local oscillator frequencies during receive.

The module contains one VCO and three outputs. One for producing carrier frequencies during transmit and one for producing the local oscillator frequency during receive and the other output is for PLL IC (IC1) Fin.

The module also has Rx and TX powerline filters.

### RX and TX power line filters

Transistor Q301 is configured as a 5v power supply ripple filter. The filter reduces the noise on the carrier and local oscillator signals.

### VCO

The VCO comprises Q302, Coil L304, and varactor D301 D302 and is configured as a Colpits oscillator. D301 D302 produces a change in frequency with a change in DC voltage and is controlled by the tuning voltage signal present at the cathode. The local oscillator programmable dividers. DATA is received by IC1 at pin 10 from pin 11 of IC501.

The RF signal at the collector of Q302 is applied to an amplifier/buffer Q305. The amplified signal from Q305 passes to the prescaler IC1 pin 8. The RF signal at the collector of Q302 also drives the cascode amplifier/buffer formed by Q304 and Q305.

When D2 is forward biased (TX ON), carrier frequencies at the collector of Q304 pass to the power amplifier and harmonic filter. When D303 is forward biased (RX), local oscillator frequencies at the collector of Q304 pass to the first mixer (IC8). VC301 adjusts the tuning voltage of the VCO to the correct operating point.

### PLL IC

The reference frequency from the TCXO, at 12.8 MHz, is connected to pin 1 of IC1 (MB1504). The appropriate VCO is connected to pin 11.

REFDIV divides the 12.8 MHz to produce a reference frequency ( $F_r$ ) of 5 or 6.25 kHz dependent upon channel spacing selected. VARDIV divides the prescaled VCO frequency to produce a variable frequency ( $F_v$ ).  $F_v$  and  $F_r$  are fed to the phase detector.

### Phase detector

When  $F_v = F_r$ , the phase detector output (pins 15 and 16, IC1) produces narrow negative pulses and  $F_v$  and  $F_r$  pulse widths are identical. When  $F_v > F_r$  pin 15 (V) pulses negative with pin 16 (R) remaining high. When  $F_v < F_r$  pin 16 (R) pulses negative with pin 15 (V) remaining high. The signal at pin 15 and 16 is smoothed by the loop filter and applied to the VCO.

### Out-of-lock detector

The out-of-lock detector produces a series of logic level pulses when the loop is out of lock at pin 7 of IC1. The pulses at pin 7 of IC1 are buffered by Q6 and then integrated by R17 and C19. The product of the integrating circuit is fed to IC501 pin 25.

### Charge Pump and Loop Filter

Transistors Q2, Q4, Q10, and associated resistors and capacitors form the charge pump and loop filter. The phase detector output from IC1 pins 15 and 16 are combined by the charge pump to produce a 0 to 15V tuning voltage signal.

The signal is filtered by the loop filter (R13, C15 and C20) to remove any residual reference frequency harmonics from the signal. After filtering the signal is applied to the voltage controlled oscillator module.

### DC to DC Converter

The DC to DC converter, converts the +7.5 V to a 14-16 V supply. This is used to provide the tuning voltage for the VCO. A wide voltage range is required to allow for the wideband operation of the radio.

Q506 to Q508, and associated components, form a 200kHz oscillator. The output of the oscillator is rectified and filtered by D503, D506, C548 and C11. The resultant 16Vdc is passed to R544 and then becomes the supply rail for the charge pump.

### Dual modulus prescaler

The prescaler divides the VCO frequency by 64 or 65.

### Transmitter

The transmitter comprises:

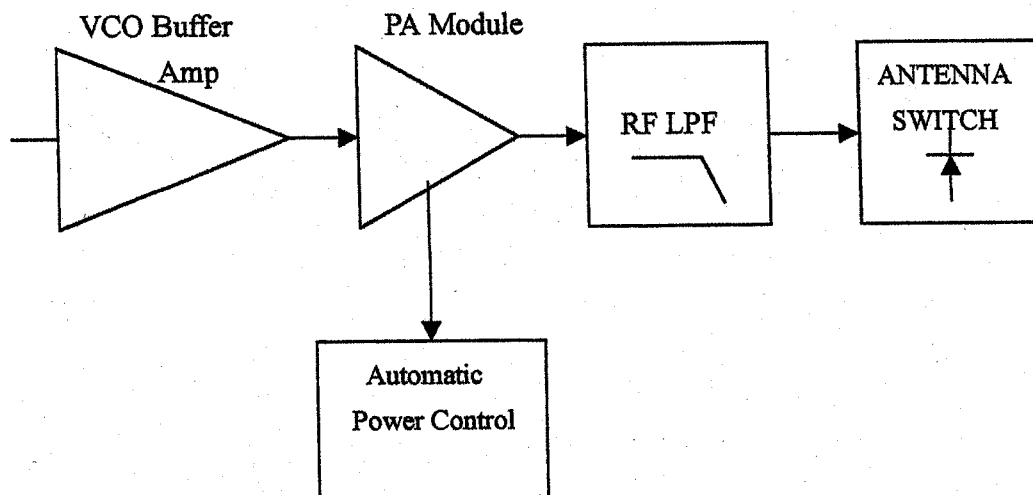

## **Buffer**

When the radio is in transmit mode the diode D2 is forward biased enabling the modulated RF signal from the VCO to pass to the buffer/pre-amplifier Q21 and Q22 and associated components.

The output signal is passed from Q22 to IC5 via a matching network consisting of Inductor L7 and C73.

## **PA module**

The signal is then amplified for transmission by IC5, which is a power amplifier module.

## **Low pass filter**

The amplified RF signal is passed through the stripline coupler and is fed to the harmonic low pass filter, comprising L12 to L15 and C94-C98 and then to the antenna connector (ANT). The stripline coupler provides a sample of the RF signal for the automatic power control.

## **Antenna Switch**

When transmitting, the diodes D5 and D6 are forward biased, allowing the RF to pass to the antenna. D6 is shorted to ground which makes L11 look open circuit (1/4 wave tuned stub). This prevents the TX signal from passing to the receiver stage.

## **Automatic power control (APC) circuits**

The automatic power control contains the stripline coupler, diode D4, variable resistor RV1, IC4A and transistors Q19 and Q23.

The RF signal present in the coupler is rectified by D4, to produce a DC voltage. This DC voltage is passed to one input of U4A, which is a differential amplifier. In transmit mode a DC reference level for U4A is supplied by the potential divider R34/R35.

The reference level and the detected level from D4 are compared a difference signal is produced. The difference signal drives Q19, which then drives Q23. Q23 controls the supply voltage to the first amplifier stage in IC5. This control loop produces a constant power output at the antenna connector ( ANT ).

RV1 is used to adjust the voltage that is fed back from D4 which defines the output RF power level.

# Receiver

The receiver comprises:

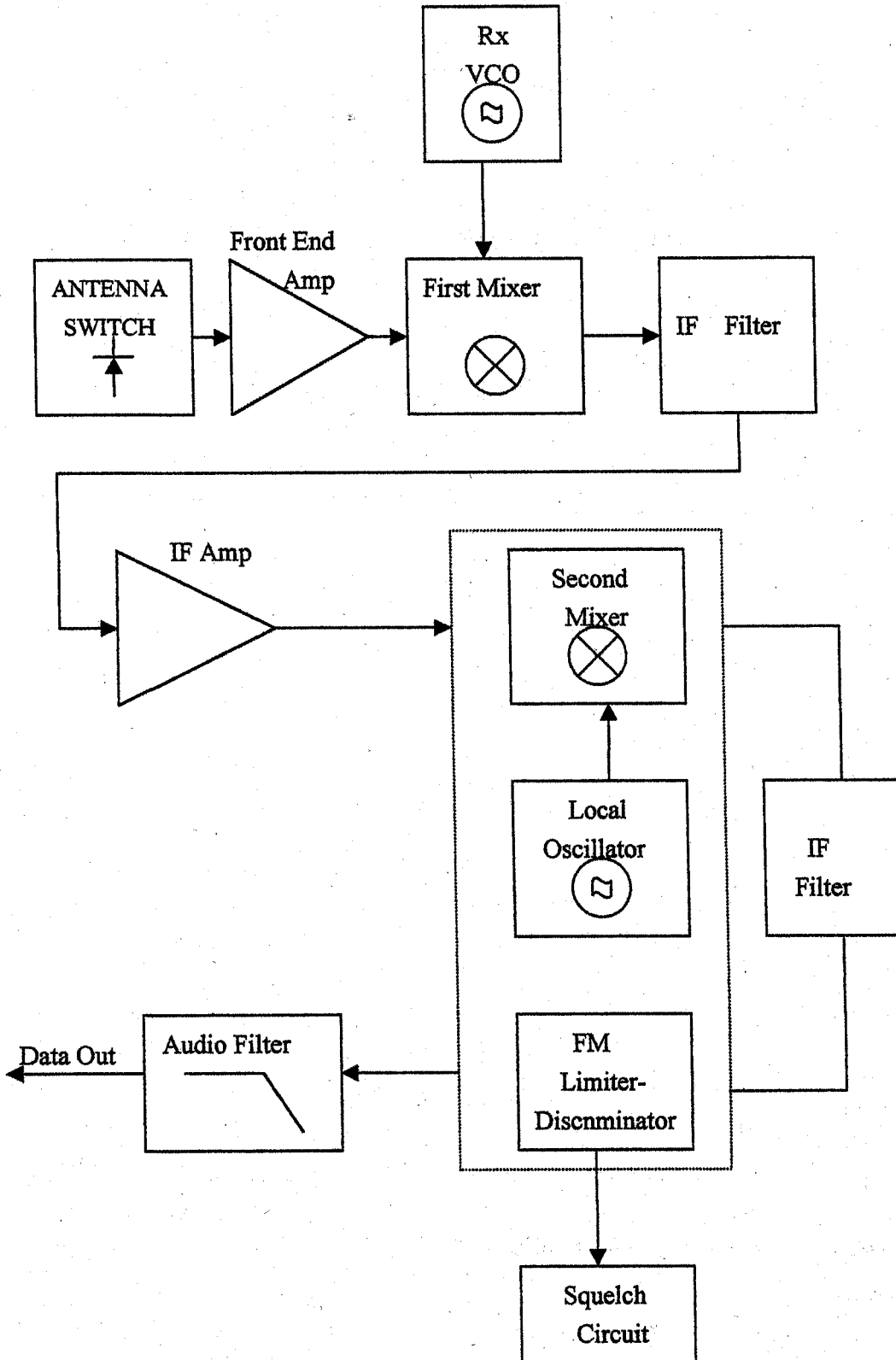

## **Antenna Switch**

In receive, the diode D5 and D6 are reverse biased. L11 is now in circuit, passing the signal from the antenna to the front end without signal loss.

## **Front End**

The receiver signal is routed to pin 1 of the RF Front End module. It passes through the band pass filter consisting of C801 to C809/L801 to L803.

Diode D801 serves as protection from RF overload from nearby transmitters.

The input signal is coupled to the base of Q801 which serves as an RF amplifier. The output of Q801 is then coupled to a second bandpass filter consisting of C812 to C823 / L804 to L807.

The output of the front end module, pin6, is then coupled to the double-balanced mixer IC8.

The receiver front end module is factory pre-tuned and requires no adjustment. Repair is effected by replacement of the entire module.

The modules are:

- U1 400MHz to 430MHz
- U2 439MHz to 470MHz
- U3 420MHz to 450MHz

## **First Mixer**

IC8, 2-pole crystal filters XF1 and XF2 and coils L16 and L18 form the First Mixer and First IF Filter.

IC8 is a self contained double balanced mixer. The RF signal, from the front end is applied to pin 4 and the VCO local oscillator signal is applied to pin 1.

The difference frequency of 45 MHz is taken from pin 5 and is filtered by the crystal filters XF1 and XF2. The tuned circuits L16 and L18 and associated components provide matching of the crystal filters to ensure a good pass-band response and selectivity.

The IF signal is amplified by Q24 and passed to the FM Detector IC.

## **Second mixer, Second IF, FM detector**

The output of the IF amplifier is fed into the narrowband FM IF Integrated Circuit, IC6 (MC3371). This is a single conversion FM receiver which contains the second mixer, second IF amplifier, and FM detector.

Crystal X1, connected to pin 1 of IC6, determines the second local oscillator frequency. In this case the crystal has a frequency of 44.545MHz. The first IF signal is applied to the mixer and resultant frequency of 455KHz, is the difference between the IF signal and second local oscillator.

The 455KHz IF signal is output from pin 3 and is applied to a 455KHz band-pass filter, CF1(20/25 kHz channel spacing) or CF2 (12.5 kHz channel spacing). The selection of the filters is accomplished by diodes D13(input) and D14(output) whose bias is controlled by software and applied to the diodes from pin 21 of IC501.

The output of CF1/CF2 is passed via pin 5 to a high gain IF amplifier coupled to the adjustable quadrature detector T2 (pin 8). Any detected signal is produced at pin 9 of IC6 and applied to the Receiver Audio Circuit and the Mute (Squelch) Circuit.

### **Squelch ( MUTE ) Circuit**

The noise detect circuit in conjunction with IC6 consists of diode D11 and RV2.

Any noise signal is amplified by IC6 internal noise amplifier rectified by D11 .D11 Signal is applied to pin12 of IC6. The squelch trigger output (pin 14,IC6) is applied to the pin 6 of J501.

When noise is present, the voltage at pin 12 of IC6 is less than 0.7V. The squelch trigger output is 0V(logic 0) It's make pin 6 of J501 open state.

When no noise is present, the voltage at pin 12 of IC6 exceeds 0.7v and pin 14 of IC6 IS AT 5v(logic 1). This make pin 6 of J501 short state.

### **Carrier Detect**

A Carrier Detect ( MUTE DETECT ) output is available on pin 6 of J501 .

### **AF Output Low Pass Filter**

A low pass filter formed by C134, C135 and R82 removes any extraneous 455kHz energy from the AF output of the FM receiver chip (pin 9 of IC6).

The filtered signal is passed to pin 2 of J501.

### **Microcontroller**

The PIC 16C57 microcontroller IC controls the programmable features and frequency synthesizer Data.



## **Programming Mode**

The programming mode allows the user to retrieve or program TX/RX frequencies, HI/LO power Setting and channel spacing ,when pin 9 of J501 is set to ground. Programming mode will Inhibit , Serial communications can then be made in order to read/program the on- board EEPROM ( IC502 )which contains radio- specific data.

## **EEPROM**

Relevant channel information, such as Rx/ Tx frequencies, is stored in the EEPROM( IC502) which is a 93C46. This information may be programmed and erased via the D- type socket. The EEPROM has 1024 (8x128) capacity and is written serially.

## **Power supply circuit**

The data radio is supplied with a nominal + 13.8V dc power supply input from external equipment which is filtered using C532 ,L501 and C533.This supply is converted into three separate voltage levels on the board using the switching transistor Q506 and associated components .

The +13.8Vdc supply and Q506 switching waveform are summed using D503 to supply a boosted voltage supply which is regulated at +16V using Zener diode D506 .This supply is used as the supply for the tuning voltage for the VCOs.

The +6V line is regulated by Zener diode D505 and filtered using L503 and C538.This +6V line is fed to the RF circuit and is regulated to +5V using two regulators on the board.