

NOKIA

Nokia MetroSite EDGE Base Station

Installation

The information in this documentation is subject to change without notice and describes only the product defined in the introduction of this documentation. This documentation is intended for the use of Nokia's customers only for the purposes of the agreement under which the documentation is submitted, and no part of it may be reproduced or transmitted in any form or means without the prior written permission of Nokia. The documentation has been prepared to be used by professional and properly trained personnel, and the customer assumes full responsibility when using it. Nokia welcomes customer comments as part of the process of continuous development and improvement of the documentation.

The information or statements given in this documentation concerning the suitability, capacity, or performance of the mentioned hardware or software products cannot be considered binding but shall be defined in the agreement made between Nokia and the customer. However, Nokia has made all reasonable efforts to ensure that the instructions contained in the documentation are adequate and free of material errors and omissions. Nokia will, if necessary, explain issues which may not be covered by the documentation.

Nokia's liability for any errors in the documentation is limited to the documentary correction of errors. **NOKIA WILL NOT BE RESPONSIBLE IN ANY EVENT FOR ERRORS IN THIS DOCUMENTATION OR FOR ANY DAMAGES, INCIDENTAL OR CONSEQUENTIAL (INCLUDING MONETARY LOSSES)**, that might arise from the use of this documentation or the information in it.

This documentation and the product it describes are considered protected by copyright according to the applicable laws.

NOKIA logo is a registered trademark of Nokia Corporation.

Other product names mentioned in this documentation may be trademarks of their respective companies, and they are mentioned for identification purposes only.

Copyright © Nokia Corporation 2002. All rights reserved.



CE 0523 ⓘ	<p>Hereby, Nokia Corporation, declares that this product is in compliance with the essential requirements and other relevant provisions of Directive: 1999/5/EC.</p> <p>The product is marked with the CE marking and Notified Body number according to the Directive 1999/5/EC</p>
FCC	<p>FCC §15.21 - Information to user - This product is used as an intentional radiated equipment and any changes or modifications on the equipment without any approval by Nokia could void the user's authority to operate the equipment.</p> <p>FCC §15.105 - Information to user - This equipment has been tested and found to comply with the limits for a Class B digital device, pursuant to part 15 of the FCC Rules. These limits are designed to provide reasonable protection against harmful interference in a residential installation. This equipment generates, uses and can radiate radio frequency energy and, if not installed and used in accordance with the instructions, may cause harmful interference to radio communications. However, there is no guarantee that interference will not occur in a particular installation. If this equipment does cause harmful interference to radio or television reception, which can be determined by turning the equipment off and on, the user is encouraged to try to correct the interference by one or more of the following measures:</p> <ul style="list-style-type: none">• Reorient or relocate the receiving antenna.• Increase the separation between the equipment and receiver.• Connect the equipment into an outlet on a circuit different from that to which the receiver is connected.• Consult the dealer or an experienced radio/TV technician for help.

For the MetroSite EDGE to be used in the USA and continue to meet the FCC certification granted, it must be noted that the following channels are either blocked, or can not be operated at a higher power level than stated below.

For use in the GSM 800 band

Channel 128 - For GMSK, Maximum Power Level 3 - For 8PSK (EDGE), Maximum Power Level 4

Channel 182 - Blocked for both GMSK and 8PSK (EDGE)

Channel 232 - Blocked for both GMSK and 8PSK (EDGE)

Channel 239 - For GMSK, Maximum Power Level 13 - For 8PSK (EDGE), transmission is Blocked

Channel 240 - For GMSK, Maximum Power Level 13 - For 8PSK (EDGE), transmission is Blocked

Channel 251 - For GMSK, Maximum Power Level 1

For use in the GSM 1900 band

Channel 586 - Blocked for both GMSK and 8PSK (EDGE)

Channel 611 - Blocked for both GMSK and 8PSK (EDGE)

Channel 686 - Blocked for both GMSK and 8PSK (EDGE)

Channel 711 - Blocked for both GMSK and 8PSK (EDGE)

Channel 736 - Blocked for both GMSK and 8PSK (EDGE)

If these channels are not blocked, or operated at the stated reduced power or lower power, then the FCC certification will be invalid.

Contents

	Contents	5
	List of tables	6
	List of figures	7
1	About this document	11
2	Working order	13
3	Preparations for installation	15
3.1	Checking the delivery	15
3.2	Checking the site	15
3.2.1	BTS interfaces and cables	16
3.3	Installation equipment	16
4	Unpacking the delivery	19
4.1	Working order for unpacking	19
4.2	Contents of the BTS transportation package	21
4.3	Contents of the pole mounting kit	22
5	Removing the units	25
6	Mounting the BTS	29
6.1	Wall mounting	30
6.2	Pole mounting	34
6.2.1	Attaching the cabinet with the small-pole mounting kit	35
6.2.2	Attaching the cabinet with the large-pole mounting kit	41
7	Reinstalling the units	49
8	Cabinet cabling	51
8.1	Preparations for cabling	51
8.2	Grounding	53
8.3	Power supply	55
8.4	Transmission unit	58
8.4.1	FC E1/T1 transmission unit	58
8.4.2	FXC E1 transmission unit	60
8.4.3	FXC E1/T1 transmission unit	61
8.4.4	FXC RRI transmission unit	62
8.5	Interface unit	63
8.6	Transceiver units (TRXs)	64
8.7	Completing the cabling	66
9	Completing the installation	69
	Index	71

List of tables

Table 1.	Working order for installing the Nokia MetroSite EDGE Base Station	13
Table 2.	Installation equipment checklist	16
Table 3.	Pre-installation parts checklist	17
Table 4.	Checklist for contents of the transportation package for the Nokia MetroSite EDGE Base Station	21
Table 5.	Checklist for contents of the optional pole mounting kit	22
Table 6.	Parts required for wall mounting	30
Table 7.	Parts and pole diameters required for pole installation	34
Table 8.	Band length for different pole diameters	41

List of figures

- Figure 1. Contents of the Nokia MetroSite EDGE Base Station transportation package when unpacked **22**
- Figure 2. Contents of the optional pole mounting kit **23**
- Figure 3. Connecting the antistatic wrist strap before removing any units **25**
- Figure 4. Removing the units **27**
- Figure 5. Mounting rack dimensions and screw holes **29**
- Figure 6. Cardboard template for aligning wall mounting screw holes **31**
- Figure 7. Wall mounting **33**
- Figure 8. Bracket blocks for pole mounting **35**
- Figure 9. Pre-assembling the pole brackets **36**
- Figure 10. Attaching the mounting rack and the pole brackets **38**
- Figure 11. Pole mounting with the small-pole mounting kit **40**
- Figure 12. Pole bracket pre-assembled (large-pole mounting kit) **42**
- Figure 13. Pole bracket pre-assembled (large-pole mounting kit) **43**
- Figure 14. Attaching the mounting rack and the pole brackets **45**
- Figure 15. Pole mounting with large-pole mounting kit **47**
- Figure 16. Displacing the sealing strip and removing the cable entry block screws **52**
- Figure 17. Cable routing through the cable entry block **53**
- Figure 18. Grounding connector alternatives **54**
- Figure 19. Power supply unit and power connector alternatives **57**
- Figure 20. Cabling alternatives for the FC E1/T1 transmission unit **59**
- Figure 21. Cabling of the FXC E1 transmission unit **60**
- Figure 22. Cabling of the FXC E1/T1 transmission unit **61**
- Figure 23. Cabling of the FXC RRI transmission unit **62**
- Figure 24. Cabling of the interface unit **63**
- Figure 25. Examples of diversity cabling alternatives **65**
- Figure 26. Routing the cables and closing the cable cover **67**
- Figure 27. Hanging the BTS cover **70**

Summary of changes

Version 1, 12th November 1999

Version 2, 22nd June 2000:

- Changed title
- Added GSM reference to body text
- Added CE marking
- Removed RX diversity cable from 2+1 TRX of Figure 24
- Edited Figure 26
- Removed note from alternative 1 procedure in Chapter 6.3.2
- Added BTS safety strap to Figure 1 and to list in Chapter 2.1

Version 3, 18th April 2001:

- Updated for EDGE
- Document restructured

Version 3.1, July/October 2002:

- Modifications to pole mounting kit incorporated (two types of band and locking device)
- Note added about horizontal mounting of WCUA cover

1

About this document

This document describes the installation of the Nokia MetroSite™ EDGE Base Station from delivery of the BTS package to the site to BTS commissioning. Read carefully *Nokia MetroSite EDGE Base Station: Warnings and Cautions* and *Nokia MetroSite EDGE Base Station: Requirements for Installation and Operation* before starting the installation.

The following information can be found in this document:

- Working order for installation
- Preparations before installation
- Tools and parts required
- How to safely unpack the delivery
- Contents of the BTS delivery
- How to remove and reinstall units
- How to install the BTS on a wall or a pole
- How to cable the BTS
- Completing the installation after commissioning



Caution

Installation, commissioning and maintenance of the Nokia MetroSite EDGE Base Station (BTS) may be performed only by trained and authorised personnel.

2

Working order

The Nokia MetroSite EDGE Base Station is installed upright on a pole or a wall. Pole mounting requires a pole mounting kit, which is ordered separately when required. The BTS can also be installed horizontally on its back.

Note

Horizontal mounting of the Nokia MetroSite EDGE Base Station is only suitable for certain site conditions and countries. Contact your Nokia dealer for advice.

Refer to Table 1 for the working order and location of instructions for installing the Nokia MetroSite EDGE Base Station. Removing the units before mounting is optional, depending on the number of installation personnel on the site.

Table 1. Working order for installing the Nokia MetroSite EDGE Base Station

Activity	Instructions
Preparations for installation	Chapter 3
Unpacking and checking the delivery	Chapter 4
Removing units to reduce weight when mounting the cabinet (optional)	Chapter 5
Mounting the BTS on a pole or wall	Chapter 6
Reinstalling units	Chapter 7
Cabling the BTS	Chapter 8
Completing the installation	Chapter 9

3

Preparations for installation

Before beginning installation, check the delivery, the site, and the required tools and extra parts against the relevant checklists.

Note

The installation of the Nokia MetroSite EDGE Base Station can be carried out by one person if units are removed before mounting the cabinet. However, it requires at least two people to lift a BTS with its units installed.



Caution

Use only trained and authorised personnel for installing and commissioning the Nokia MetroSite EDGE Base Station.

3.1 Checking the delivery

Before unpacking any of the packages, check that the delivery is correct. Confirm that the delivery notes on each package agree with the order note.

3.2 Checking the site

The BTS site has been planned and prepared according to the specifications given in *Nokia MetroSite EDGE Base Station: Requirements for Installation and Operation*. Before beginning installation, check the site against these specifications using a site preparation checklist.

If the site conditions do not conform to the checklist, stop the installation at this stage and return to the site preparation procedures.

3.2.1 BTS interfaces and cables

Depending on the site solution, check that the appropriate interface units and cables are on the site if cabling is to be completed during one installation. Details of the required connectors and cables are found in *Nokia MetroSite EDGE Base Station: Requirements for Installation and Operation*.

Note

Diversity cables are delivered with the BTS in the transportation package.

3.3 Installation equipment

Make sure that all the necessary installation equipment is available on the site before beginning installation. Refer to Table 2 for tools and Table 3 for parts. Detailed information on the installation equipment can be found in *Nokia MetroSite EDGE Base Station: Requirements for Installation and Operation*.

Table 2. Installation equipment checklist

Tool	Notes
Torque driver with 60 mm shaft and: <ul style="list-style-type: none"> • T10 Torx bit • 4 mm Allen bit 	Required for: <ul style="list-style-type: none"> • Unit retaining screws • BTS fixing screws, cable entry block screws, ground cable fixing
Torque socket spanner/wrench with 80 mm extension shaft and: <ul style="list-style-type: none"> • 6 mm Allen bit • 8 mm hexagon socket • 10 mm hexagon socket 	Required for: <ul style="list-style-type: none"> • Bolts in pole brackets, L-beam screws • Locking device for pole brackets, grounding cable nut • Removing grounding bridges on transmission units
Torque key	For attaching diversity cables
Side cutting pliers	For cutting cable ties and preparing grounding cable for crimp terminal
Crimping tool	For attaching crimp connector to cable in grounding alternative 1

Table 3. Pre-installation parts checklist

Part	Notes
BTS transportation package	Confirm that the correct package has been delivered
Optional pole mounting kit	For pole mounting, ordered from Nokia if required
BTS interfaces and cables	Depending on the site solution
Wall screws and anchor plugs	Supplied by installer for wall mounting, refer to Table 6 for screw specifications
Flat crimp terminal	Supplied by installer for attaching grounding cable to grounding point, alternative 1
Cable shoe terminal	Supplied by installer for attaching grounding cable to grounding point, alternative 2
Plastic cable ties	supplied by installer for securing cable routing out of the BTS

4 Unpacking the delivery

The Nokia MetroSite EDGE Base Station is delivered in a transportation package with all the ordered units pre-installed in the chassis. . The transportation package also includes equipment needed in the installation of the base station.

A pole mounting kit is required if the BTS will be mounted on a pole. This is ordered and delivered separately if needed.



WARNING

Lifting a BTS complete with units requires at least two people. The Nokia MetroSite EDGE Base Station weighs 28 to 40 kg (62 to 88 lb), depending on the number of TRXs installed.

4.1 Working order for unpacking

The procedures for unpacking include careful checking of the condition and contents of the delivery. If any defects or missing parts are noticed, the installation should be stopped and replacement parts ordered.

The following procedures should be followed in sequence.



Check the contents of the pole mounting kit

- If pole mounting is being used, check the completeness of the pole mounting kit against the checklist in Table 5.



Remove the BTS from the packaging

1. Remove the plastic wrapping from the BTS transportation package.

2. Lift the BTS out of the package and lay it horizontally. Do not stand the BTS in a vertical position. Lay the BTS onto a clean or covered surface, not directly onto the ground.
3. Save the packing cardboard from the package! The cardboard can be used as a template for defining clearances around the BTS and for marking drill hole locations for wall installation.



Check the contents of the BTS transportation package

1. Check the completeness of the delivery against the general contents checklist in Table 4.
2. Visually inspect the cover of the BTS for any defects.



Remove the BTS cover

1. Inspect the cover visually for defects before removing it.
2. Open the lock on the bottom of the BTS using the key provided. The key will remain in the lock whenever the lock is in the open position.
3. Loosen the cover by sliding it along the chassis to disengage the hooks which hold it in place. Lift the cover off when the hooks are disengaged.



Check the BTS

1. Check the completeness of the delivery against the order specifications to confirm that the delivery contains the correct unit types.
2. Visually inspect the interior of the BTS for any defects.

Note

The unused connectors on the units are protected with rubber caps. Leave the cap on the connector if the connector is not going to be used for cabling.



Remove the mounting rack

1. Make sure that you have removed the BTS cover and prepared a clean surface for working on the BTS.
2. Turn the BTS over and lay it flat on its front.
3. The mounting rack is attached to the back of the BTS for transportation. It must be removed before continuing with installation. The mounting rack can be seen in detail in Figure 7. Loosen the offset screws on the bottom and the top of the mounting rack: on the L-beam and screws B1 and B2. Do not remove the screws completely.
4. Remove the wooden spacer blocks and the mounting rack.

4.2 Contents of the BTS transportation package

Refer to Table 4 and Figure 1 for the contents of the transportation package for the Nokia MetroSite EDGE Base Station.

Table 4. Checklist for contents of the transportation package for the Nokia MetroSite EDGE Base Station

Part	Notes
BTS chassis with the ordered units pre-installed.	Shield units are installed in the slots that are not populated with functional units
BTS cover	
T-shaped mounting rack	Provides the fixing base for the BTS
Two Allen screws, M6 x 20	For fixing the BTS to the mounting rack
Cable cover	For cables routed out of the BTS
Cable cover support	Mounting for the cable cover
Diversity cables	
Safety strap	For securing the cover to the chassis
Four unit retaining screws	Spare parts
Spare counterparts for the unit retaining screws	Attached to the uppermost TRX guide beam on the top of the BTS
Key for BTS lock	

Nokia MetroSite BTS cover and chassis with the ordered units

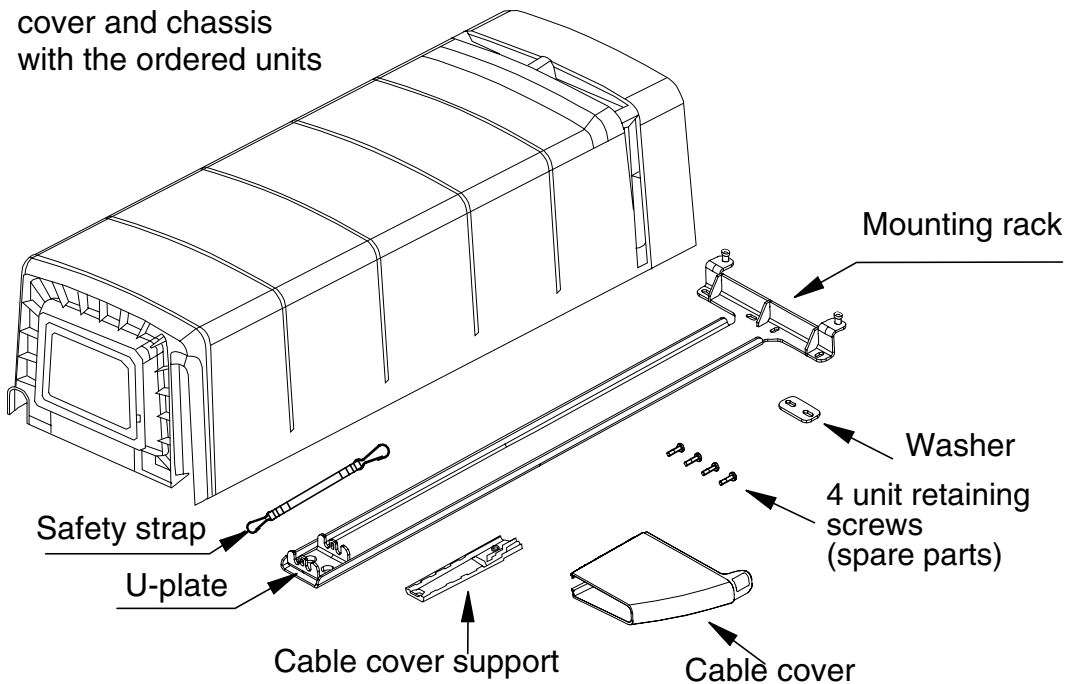

Figure 1. Contents of the Nokia MetroSite EDGE Base Station transportation package when unpacked

4.3 Contents of the pole mounting kit

The pole mounting kit is ordered as an option when required. Refer to Table 5 and Figure 2 for the contents of the pole mounting kit.

Table 5. Checklist for contents of the optional pole mounting kit

Part	Notes
Two front bracket blocks	Upper and lower bracket blocks are identical.
Two back bracket blocks	Upper and lower bracket blocks are identical.
Four Allen screws, M6 x 20	For fixing the front bracket blocks to the mounting rack.
Four long bolts, M8 x 120	For fixing the back block to the front block (smaller diameter poles).

Table 5. Checklist for contents of the optional pole mounting kit (Continued)

Part	Notes
Four flat washers	
Four flat, square nuts, 20 x 20 x 4 mm	For fixing the back bracket block to the front bracket block (smaller diameter poles).
Two metal bands 1010 mm (39.8 in.)	For fixing the front bracket block to the pole (larger diameter poles).
Two locking devices	Worm drive clamps with hexagon nut/screw, for tightening the metal band to the pole (larger diameter poles). There are two types of locking device, as described in Section 6.2.2.

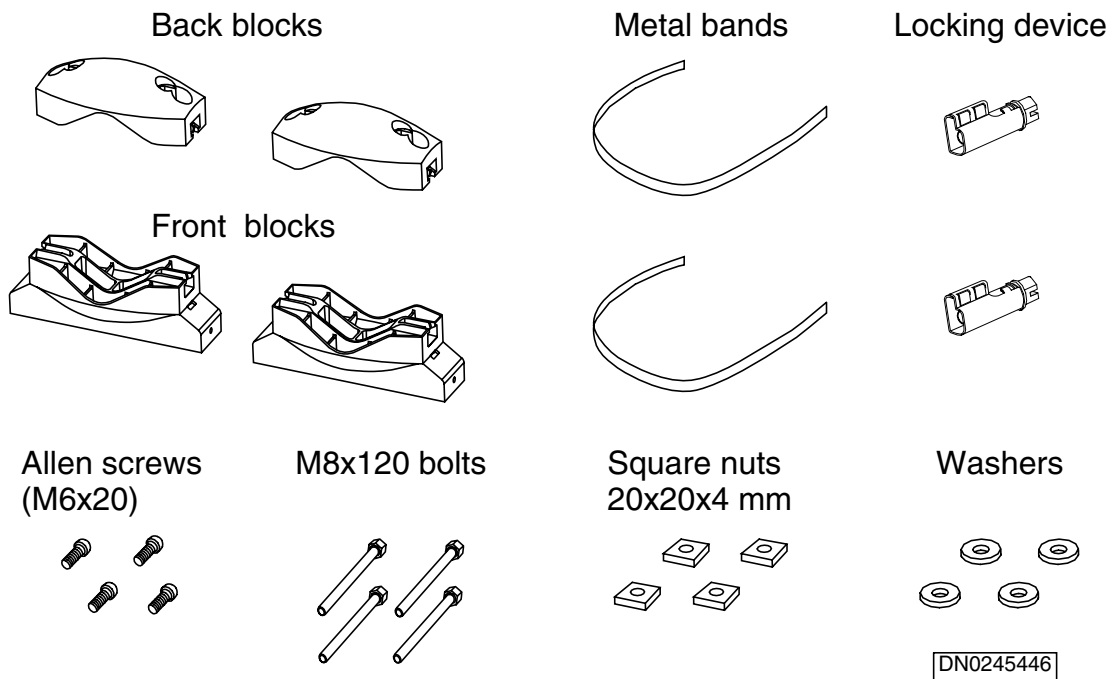

Figure 2. Contents of the optional pole mounting kit

5

Removing the units

Units can be removed from the chassis in order to make the BTS easier to handle during installation. The TRXs are the heaviest units, weighing approximately 4.5 kg (9.9 lb) each. Do not remove the shield units.

⚠ Caution

Always use the antistatic wrist strap when removing or installing the units. For more information on electro-static discharge protection, refer to *Nokia MetroSite EDGE Base Station: Warnings and Cautions*. The wrist strap and the connection point are shown in Figure 3.

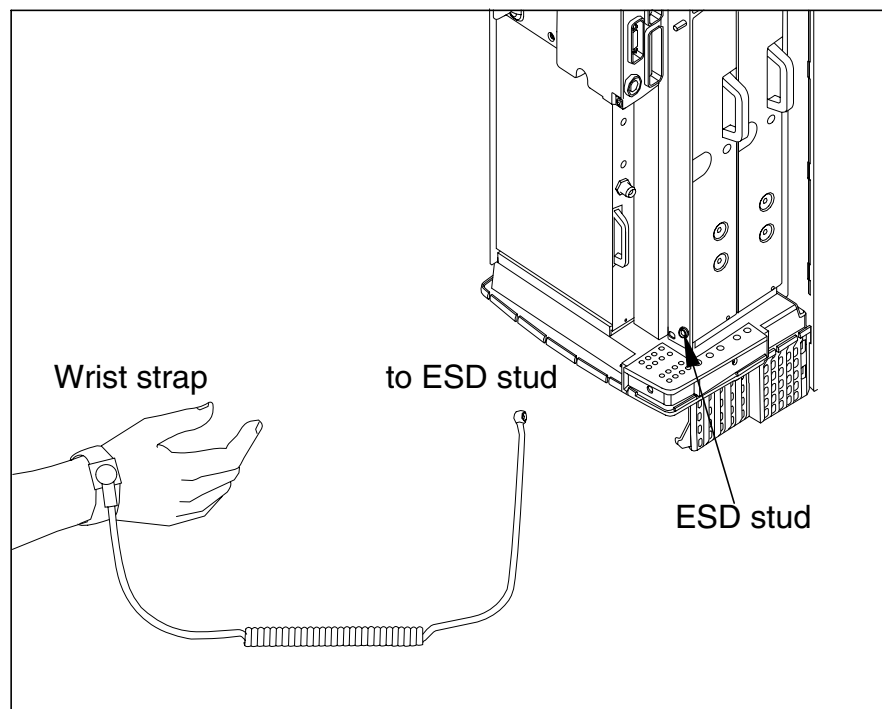

Figure 3. Connecting the antistatic wrist strap before removing any units



Removing a unit

1. Lay the BTS on its back, in the position shown in Figure 4.
2. Loosen the upper and lower retaining screws of the unit to be removed using a torque driver with a T10 Torx bit.

Loosen the screws enough to remove the unit, but leave them engaged in the threads. By doing this, the screws remain in the optimal position for reconnecting.

3. Slide the TRX units out of the slots by pulling from the handle on the front panel of the TRX.
4. Remove the power supply unit, interface unit, and transmission unit by pulling each unit out until it comes to a stop. Then lift the unit upwards and outwards to remove it. See Figure 4.

Note

If the unit does not come out easily, rock it slightly from left to right using the handle and then pull the unit out. Do not use excessive force!



Caution

When handling the units, beware of sharp edges!

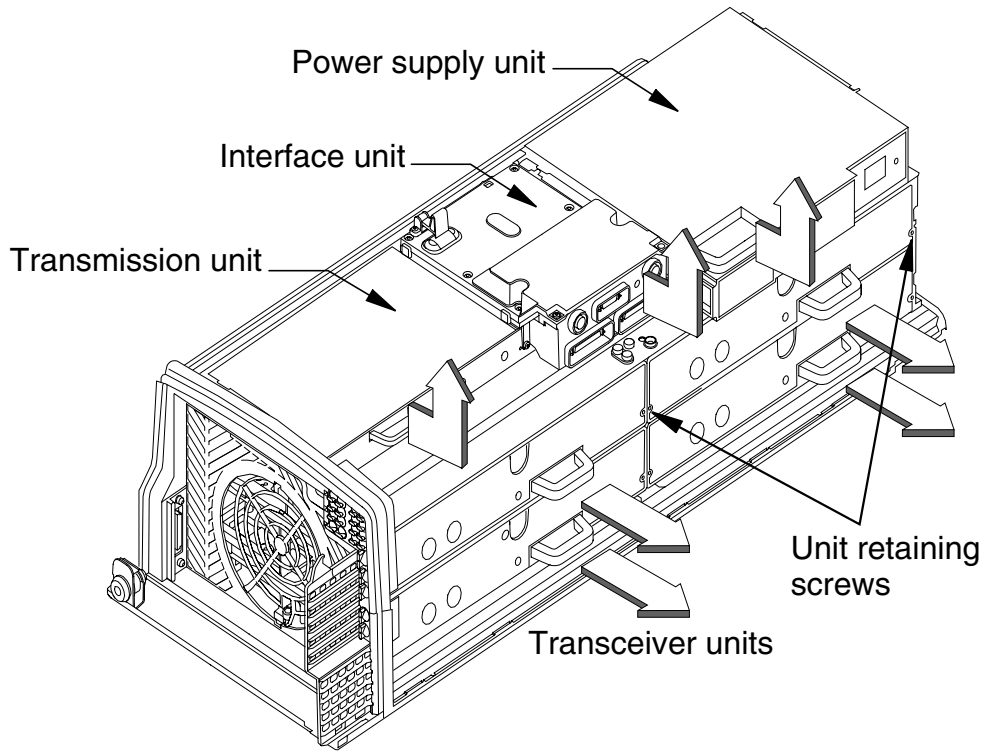

Figure 4. Removing the units



Caution

Handle the units with care. Do not knock the units or place them with their connectors facing the ground. Prevent dirt, water, or snow from entering the connectors.

6 Mounting the BTS

The mounting rack is used in both wall and pole installations to provide a fixing base for the Nokia MetroSite EDGE Base Station. The dimensions of the mounting rack are presented in Figure 5. Screw holes R1, R2, R3, R4, R5, and R6 are for fixing the mounting rack onto the wall or the pole bracket. Screw holes B1 and B2 are used for fixing the BTS to the mounting rack.

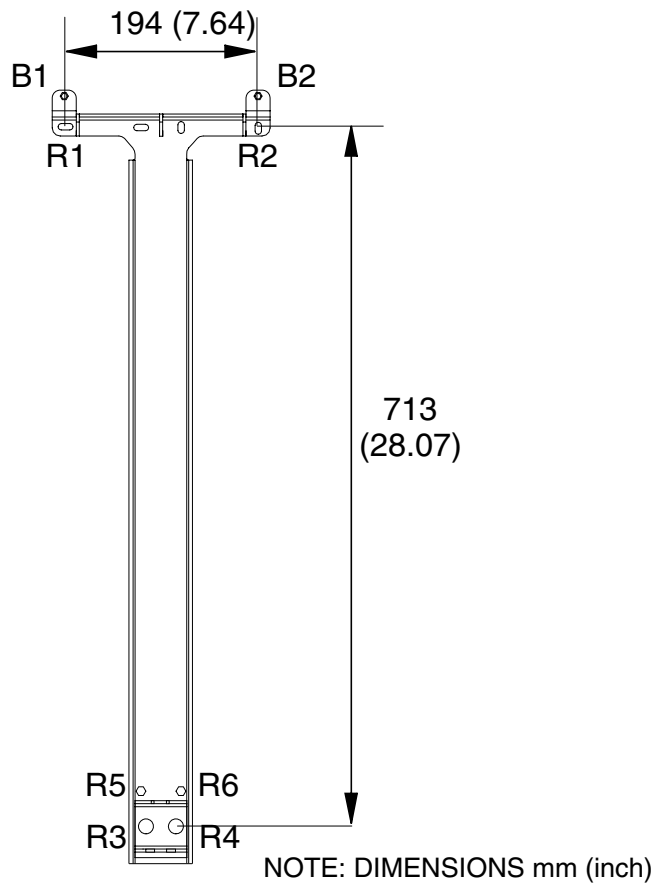

Figure 5. Mounting rack dimensions and screw holes

The Nokia MetroSite EDGE Base Station can be installed in a vertical position or in a horizontal position. For more information on the permitted mounting positions, refer to *Nokia MetroSite EDGE Base Station: Requirements for Installation and Operation*.

Note

Horizontal installation is done in the same manner as wall mounting.

Horizontal mounting is not recommended for all site conditions. Nokia MetroSite EDGE BTSs fitted with the WCUA type cover are not suitable for horizontal mounting. Contact your Nokia representative for more information.

6.1 Wall mounting

The mounting rack is attached to a suitable wall with screws and the BTS is then fixed to the mounting rack. Screw hole positions are marked out on the wall using the cardboard template which came with the BTS transportation package (see Figure 6). The required wall screws are provided by the installer, according to the specifications given in Table 6.

Table 6. Parts required for wall mounting

Part	Notes
Mounting rack	Provided in the BTS transportation package
Cardboard template to show screw hole positions and minimum clearance around the BTS	Provided as part of the BTS transportation package
Four anchor plugs for M6 wall screws	To provide a secure fixing for the wall screws
Four wall screws, M6, stainless steel, minimum tensile strength (R_m) of 600 N/mm ²	Refer to ISO 3506-1 for details

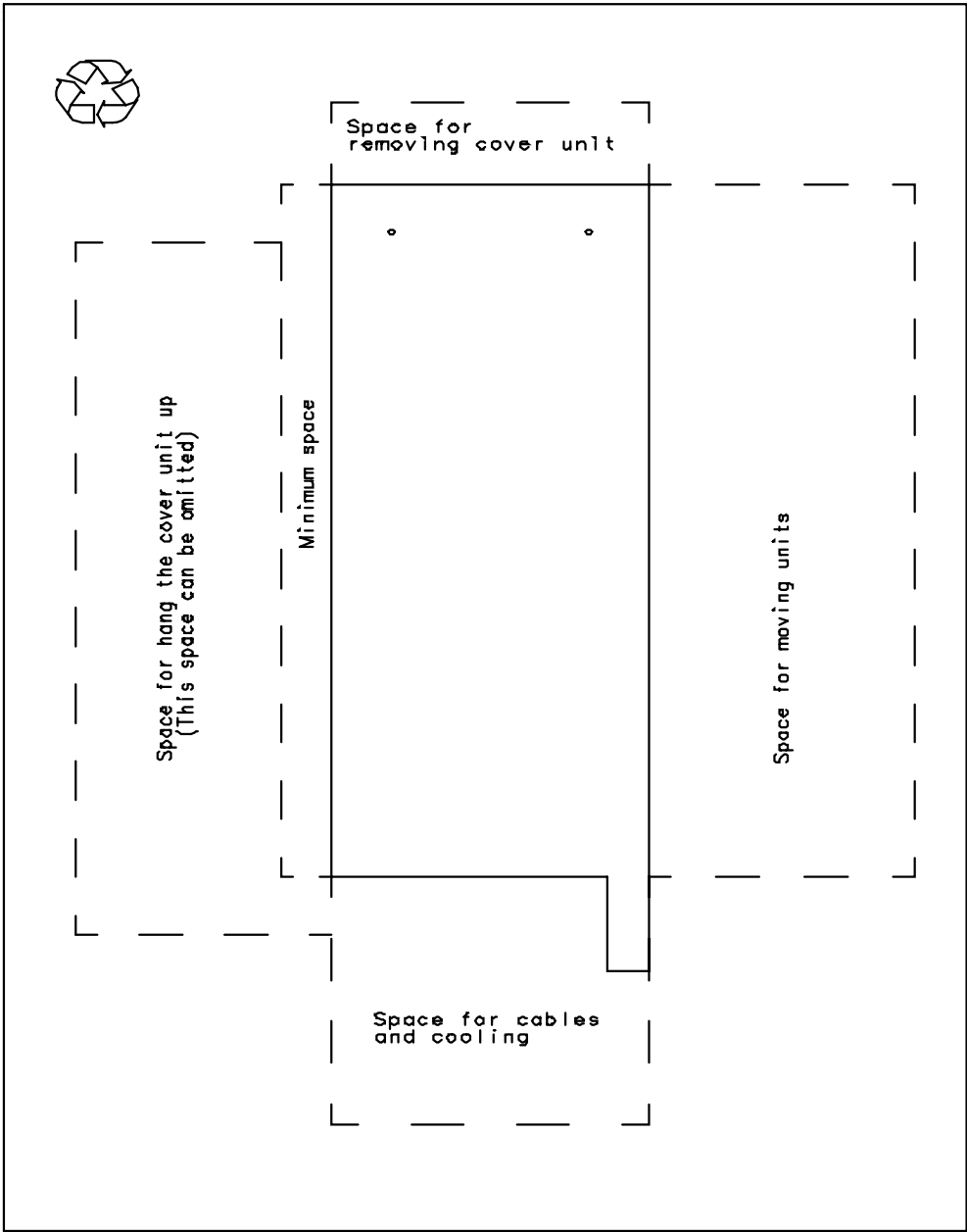

Figure 6. Cardboard template for aligning wall mounting screw holes



Fixing the mounting rack to the wall

1. To define clearances required around the BTS, cut the template out of the packing cardboard by following the dotted line (see Figure 6).
2. Find a wall area which is large enough to cover all parts of the template and place the cardboard template on the wall at the required height. Use a spirit level to check that the template is in a straight position.
3. Mark the fixing points on the wall for the upper screw holes of the mounting rack (R1 and R2, see Figure 5). For example, use a centre punch through the template to mark the fixing points.
4. Drill holes R1 and R2 in the wall and clean them out. Insert anchor plugs (or an appropriate counterpart, depending on the material) into the wall.
5. Position the mounting rack in the correct location on the wall and attach it with screws through holes R1 and R2 (see Figure 7). Use a spirit level to set the mounting rack straight (adjustment is possible due to the oval shape of holes R1 and R2). Tighten the screws when the rack is level.
6. Drill screw holes for the lower anchor screws through the holes marked R3 and R4 in Figure 7. Insert the anchor plugs (or appropriate counterparts) into the wall.
7. Position the rectangle shaped washer over screw holes R3 and R4 and insert and tighten the screws.

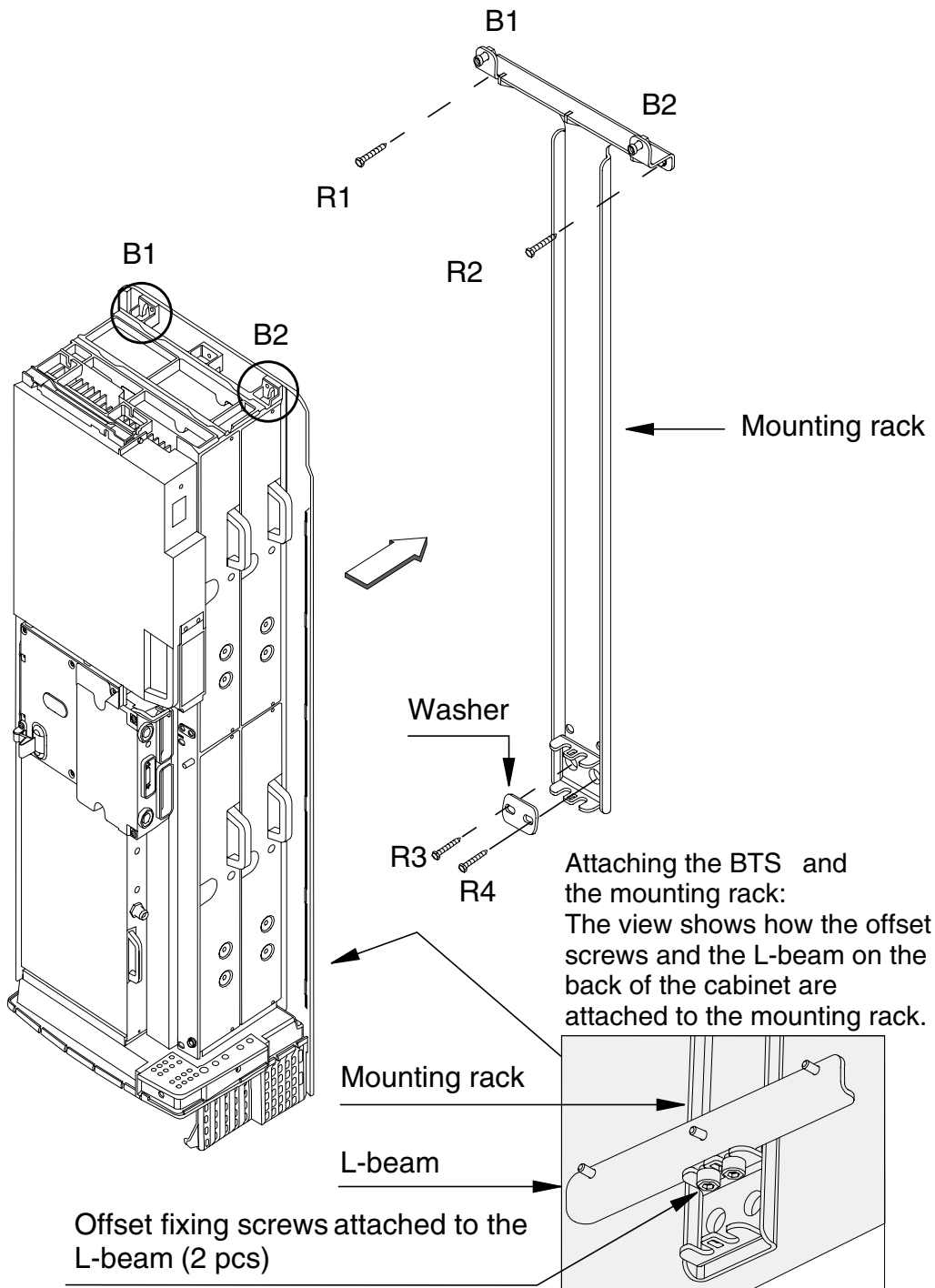

Figure 7. Wall mounting



Fixing the BTS to the mounting rack

1. Hang the BTS on the upper fixing screws, B1 and B2 in Figure 7. Do not tighten them yet!
2. Position the two offset screws which are attached to the L-beam (on the back of the cabinet) into the offset screw slots on the lower part of the mounting rack, as shown in the inset illustration in Figure 7.
3. Tighten the upper BTS fixing screws (B1 and B2 in Figure 7) using a torque driver and a 4 mm Allen bit with a shaft of at least 60 mm in length. Tighten the screws to 5.5 Nm (4.06 lb ft).
4. Tighten the offset screws on the L-beam to 12 Nm (8.85 lb ft) using a torque socket spanner/wrench and a 6 mm Allen bit with an 80 mm extension. See the inset illustration in Figure 7, which shows the rear view of the cabinet.
5. If you have removed any of the units, proceed to Chapter 7. If you have not removed any units, proceed directly to Chapter 8.

6.2 Pole mounting

Pole mounting includes three work phases:

1. Pre-assembling the pole brackets.
2. Installing the pole brackets and the mounting rack on the pole.
3. Fixing the BTS to the mounting rack.

Table 7. Parts and pole diameters required for pole installation

Part	Notes
Mounting rack	Provided in the BTS transportation package
Pole mounting kit, containing: <ul style="list-style-type: none"> • Small-pole kit: 2 front blocks, 2 back blocks, 4 bolts, 4 square nuts, 4 washers, 4 Allen screws • Large-pole kit: 2 front blocks, 2 metal bands, 2 locking devices, 4 Allen screws 	For poles of diameter: <ul style="list-style-type: none"> • Small poles: 60 - 120 mm (2.4 - 4.7 in) • Large poles: 120 - 300 mm (4.7 - 11.8 in)

There are two pole mounting options available with the pole mounting kit. The small-pole kit uses both front and back bracket blocks, but not the metal bands. The large-pole kit is for larger diameter poles and uses the front bracket blocks and the metal bands. Refer to Table 7 for selecting the correct mounting kit type for the pole diameter.

There are two M6 screw holes at the ends of the upper and lower front blocks (Figure 8) for fixing an optional cable rack.

6.2.1 Attaching the cabinet with the small-pole mounting kit

The mounting brackets (both upper and lower) consist of two blocks. The front block is attached to the BTS mounting rack, and the back block clamps the mounting to the pole.

The bracket blocks and their bolt holes are shown in Figure 8.

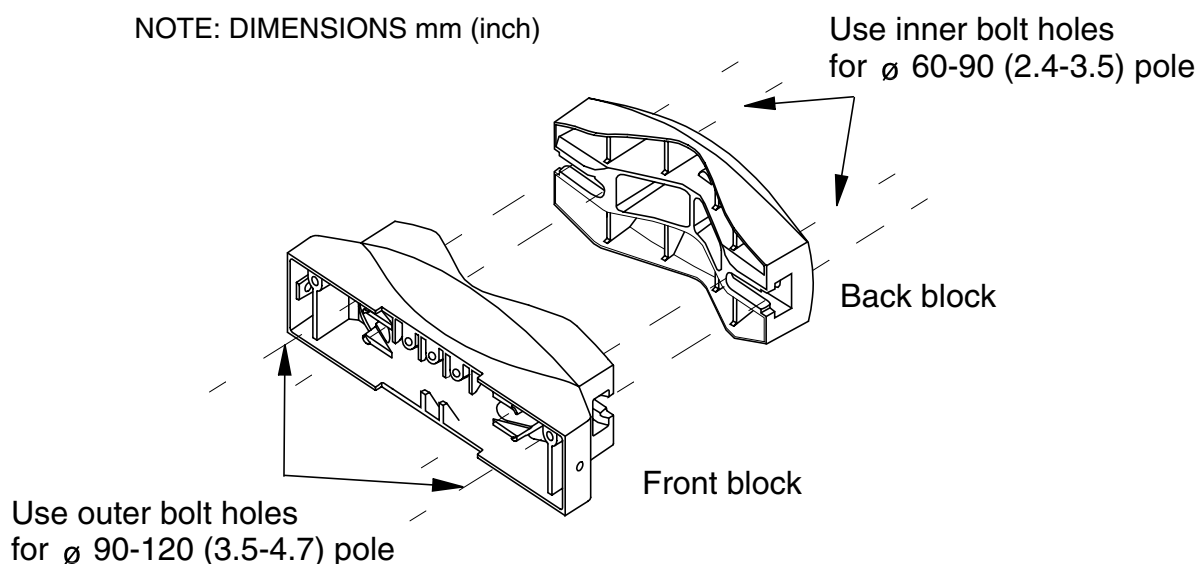

Figure 8. Bracket blocks for pole mounting

Note

If the diameter of the installation pole is 60 to 90 mm (2.4 to 3.5 in), use the inner bolt holes. If the diameter of the installation pole is 90 to 120 mm (3.5 to 4.7 in), use the outer holes. Figure 9 shows the inner bolt holes being used.



Pre-assembling the pole brackets

1. Insert the M8 assembly bolts and washers into the bolt holes in the back blocks. See [1] in Figure 9.
2. Attach the square nuts on the ends of the bolts. Screw on the nuts just enough to secure them on the ends of the bolts. See [2] in Figure 9.
3. Slide one of the bolts with the square nut into the slot at the side of the front block. See [3] in Figure 9.
4. Screw the bolt in further, enough to prevent the bolt and the square nut from sliding out from the front block. See [4] in Figure 9.

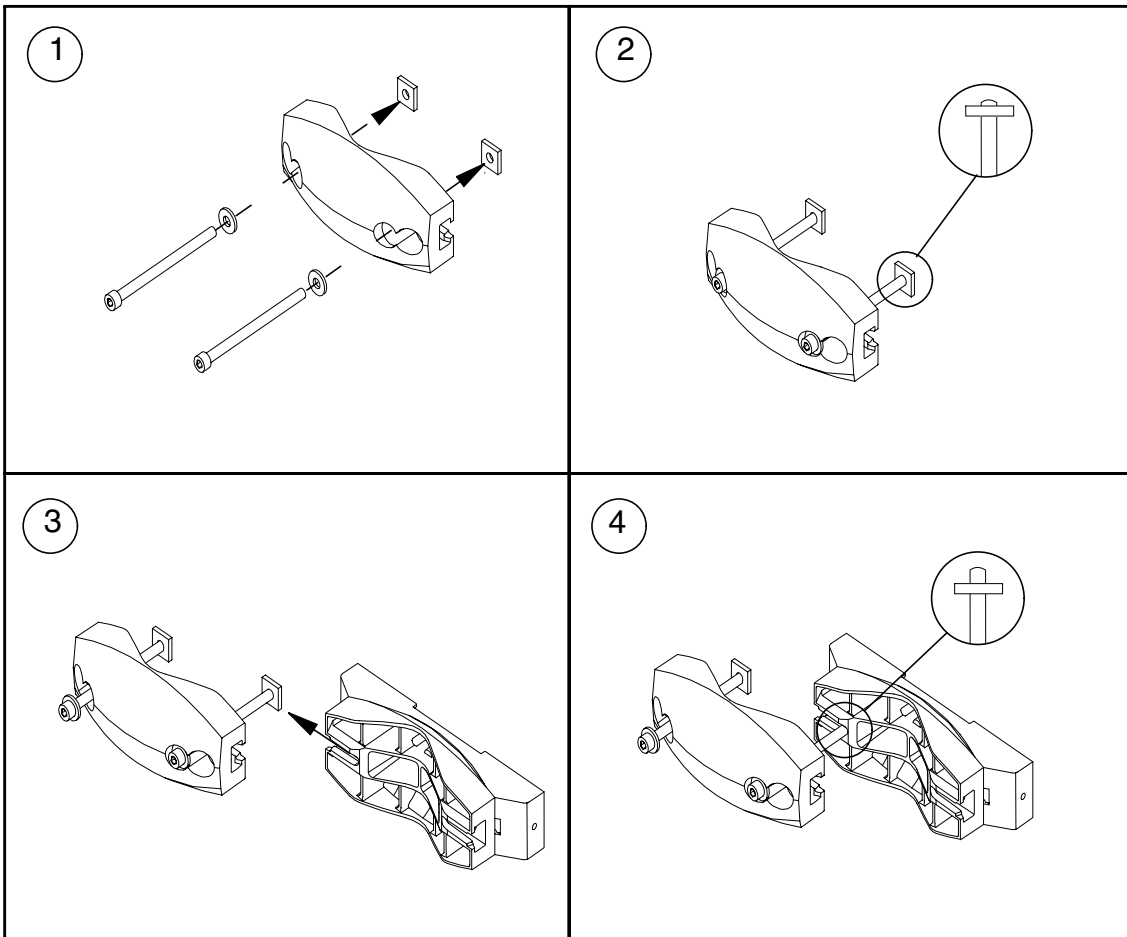

Figure 9. Pre-assembling the pole brackets



Fixing the pole brackets and the mounting rack onto a pole

Note

Before taking the mounting rack to the pole, perform the tasks instructed in Steps 1 and 2 below.

1. To fix the upper pole bracket to the mounting rack, screw the M6 x 20 Allen screws through holes R1 and R2 into the upper front block, as shown in Figure 10. Make sure that the front block is the correct way up (the set of three adjacent screw holes on the back of the block should be on the upper edge). Use a torque driver with a 4 mm Allen bit to tighten the screws to 5.5 Nm (4.06 lb ft).
2. To fix the lower pole bracket to the mounting rack, screw the M6 x 20 Allen screws through holes R5 and R6 into the lower front block, as shown in Figure 10. Make sure that the three adjacent screw holes are on the upper edge of the block. Use a torque driver with a 4 mm Allen bit to tighten the screws to 5.5 Nm (4.06 lb ft).
3. Bring the mounting rack/pole bracket combination to the pole.
4. Position the upper front block of the pole bracket on the pole. Rotate the back block so that you can insert the free bolt and square nut into the free slot on the other side of the front block.
5. Tighten the bolts in even stages to fix the upper pole bracket to the pole. Use a torque socket spanner/wrench with a 6 mm Allen bit to tighten the bolts to 12 Nm (8.85 lb ft).
6. Fix the lower bracket to the pole in the same manner as the upper bracket.

NOTE! Make sure that the three adjacent screw holes are on the upper edge of the bracket block.

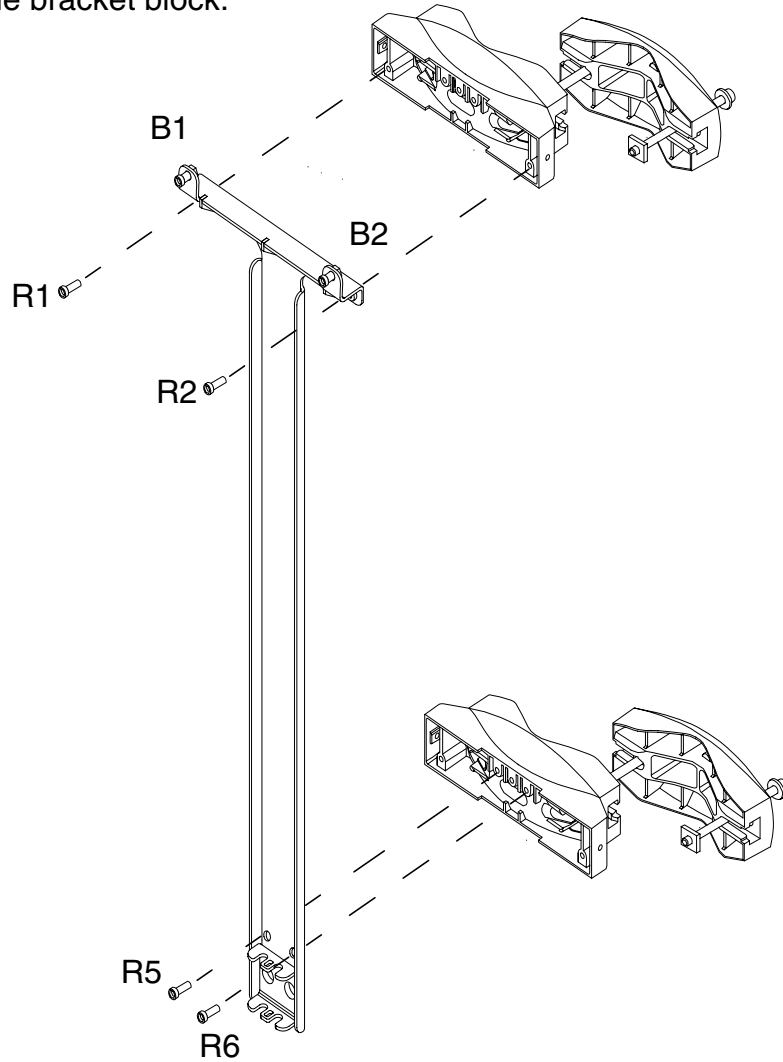

Figure 10. Attaching the mounting rack and the pole brackets



Fixing the BTS to the mounting rack

1. Bring the BTS to the mounting rack and hang it on the upper BTS fixing screws, B1 and B2 in Figure 11. Do not tighten them yet!

2. Position the two offset screws which are attached to the L-beam (on the back of the cabinet) into the offset screw slots in the lower part of the mounting rack, as shown in the inset illustration in Figure 7.
3. Tighten the upper BTS fixing screws (B1 and B2 in Figure 11) to 5.5 Nm (4.06 lb ft) using a torque driver with a 4 mm Allen bit.
4. Tighten the offset screws on the L-beam from the underside. Use a torque socket spanner/wrench with a 6 mm Allen bit and an 80 mm extension to tighten to 12 Nm (8.85 lb ft).
5. If you have removed any BTS units, proceed to Chapter 7. If you have not removed any units proceed directly to Chapter 8.

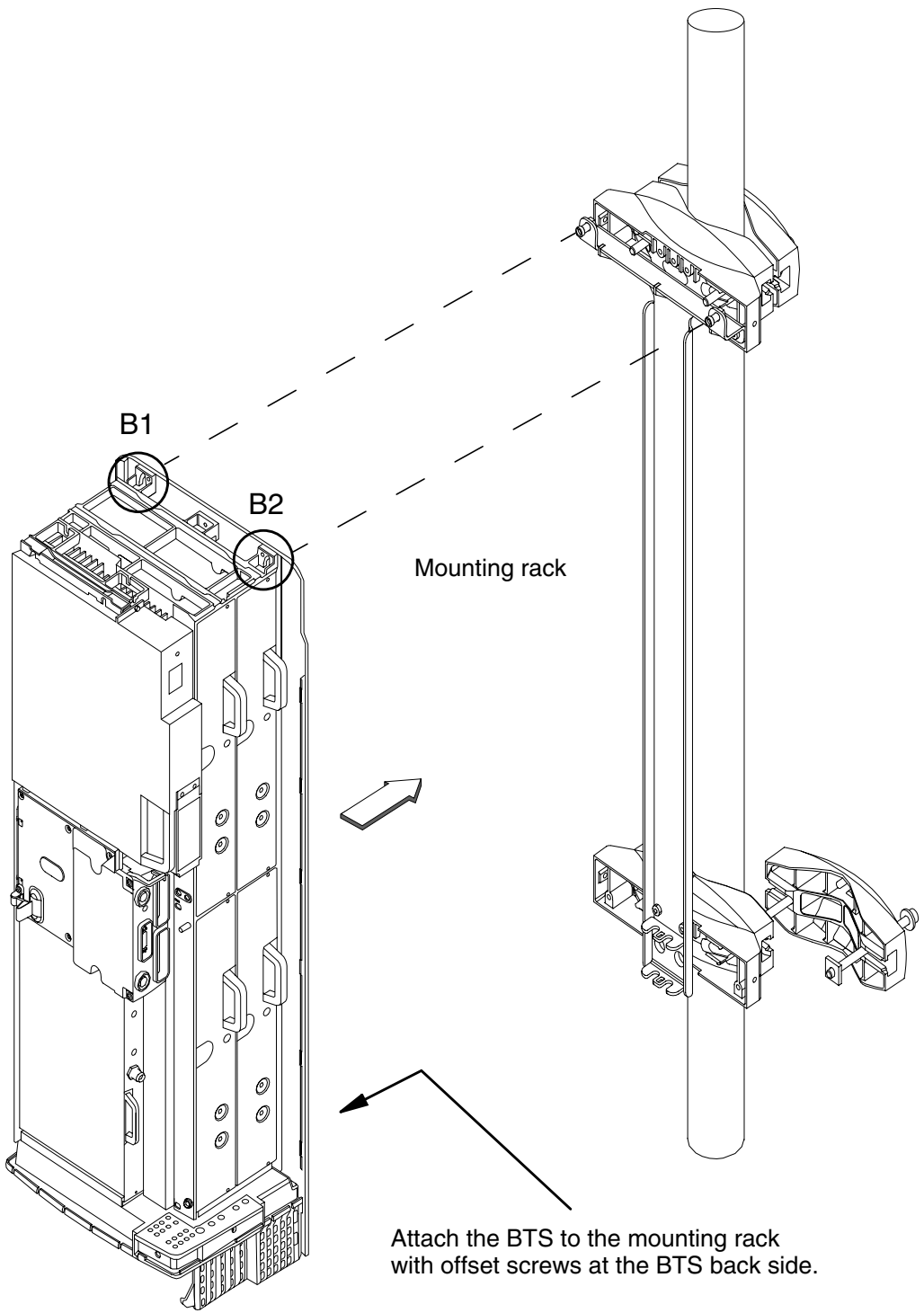

Figure 11. Pole mounting with the small-pole mounting kit

6.2.2 Attaching the cabinet with the large-pole mounting kit

With the large-pole mounting kit, the front bracket blocks are clamped to the pole with a metal band and locking device.

There are two types of band and locking device. One uses grooved metal bands, as described in procedure [A] below. The other type of locking device uses smooth bands and a locking rack, as described in procedure [B] below. Follow the procedure for the type of locking device and band in your kit.



[A] Pre-assembling the pole brackets and bands (grooved band type)

1. Assemble the locking device and band by inserting the end of the metal band approximately 25 mm (1 in.) into the locking device. The correct set up of the parts is shown in Figure 12.

Bend the surplus end of the metal band underneath the locking device, as shown in [3] [A] in Figure 12.

Flatten the bent-over end of the metal band to remove any distortion.

The locking device is now assembled.

2. Cut the metal band to the appropriate length, according to the pole diameter. Refer to Table 8 below.

Table 8. Band length for different pole diameters

Pole diameter (mm)	Band length (mm)	Pole diameter (in)	Band length (in)
140	580	5.5	22.8
160	630	6.3	24.8
180	680	7.1	26.8
200	740	7.9	29.1
220	790	8.7	31.1
240	850	9.5	33.5
260	900	10.2	35.4
280	950	11.0	37.4
300	1010	11.8	39.8

- 3. Route the metal band through the holes in the front block, as shown in [4], Figure 12.

Leave the other end of the metal band free until you have completed the next procedure (fixing the front bracket blocks to the mounting rack).

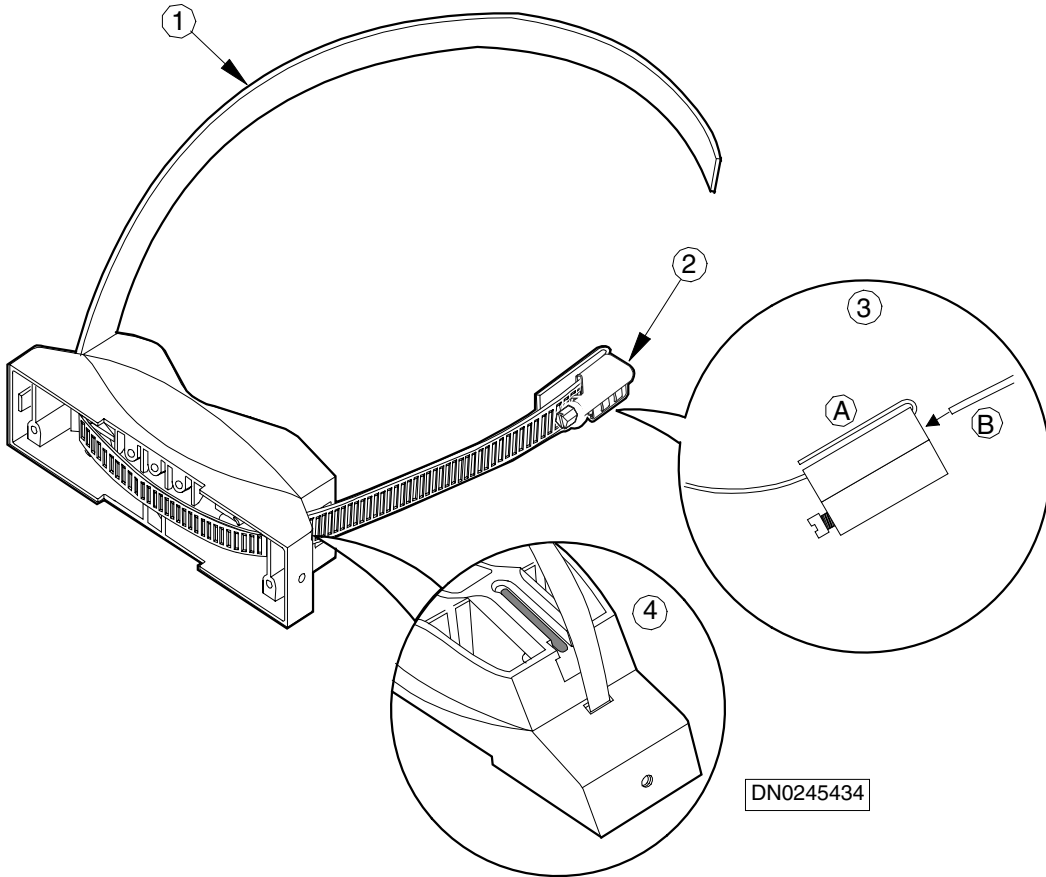

Legend:

- 1 Metal band
- 2 Locking device
- 3 Detail of locking device, attached to metal band
- 4 Detail of entry point for metal band into front bracket block

Figure 12. Pole bracket pre-assembled (large-pole mounting kit)



[B] Pre-assembling the pole brackets and bands (non-grooved band type)

1. Assemble the locking device by inserting the end of the locking rack into the worm screw housing and turning the screw to engage the rack. Make sure you have the rack the right way round when doing this. The words 'THIS SIDE UP' should be visible on the rack when the locking device is clamped around the pole. Refer to Figure 12.
2. Cut the metal band to the appropriate length, according to the pole diameter. Refer to Table 8 above.
3. Route the metal band through the holes in the front block.
4. Bend one end of the metal band over to form a hook of about 30 mm (1.2 in) in length.
5. Insert the hook into the slot at the end of the locking rack.
6. Bend the other end of the metal band over to form another hook of about 30 mm (1.2 in) in length. Leave it free for now.

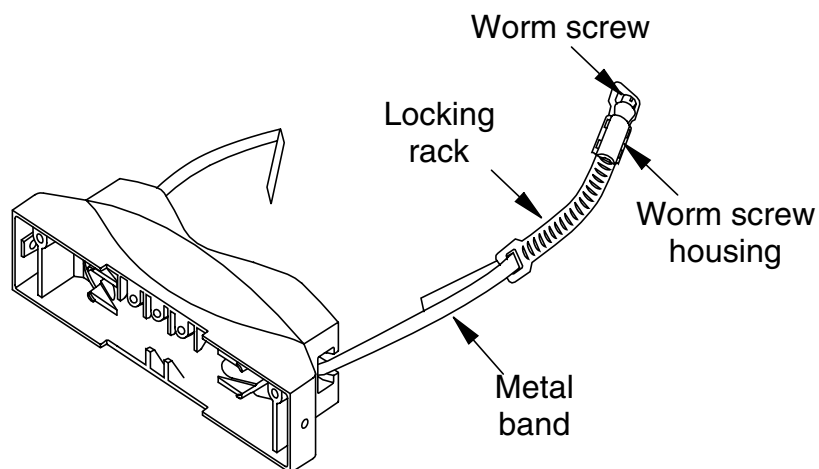

Figure 13. Pole bracket pre-assembled (large-pole mounting kit)



Fixing the pole bracket and the mounting rack to a pole

Note

Before taking the mounting rack up the pole, perform the tasks instructed in Steps 1 and 2 below.

1. Fix the upper pole bracket to the mounting rack by screwing the M6 x 20 Allen screws through R1 and R2 into the upper front block, as shown in Figure 14. Make sure that the front block is the correct way up (the set of three adjacent screw holes should be on the upper edge of the bracket). Use a torque driver with a 4 mm Allen bit to tighten the screws to 5.5 Nm (4.06 lb ft).
2. Fix the lower pole bracket to the mounting rack by screwing the M6 x 20 Allen screws through R5 and R6 into the lower block, as shown in Figure 14. Make sure that the set of three adjacent screw holes is on the upper edge of the bracket. Use a torque driver with a 4 mm Allen bit to tighten the screws to 5.5 Nm (4.06 lb ft).
3. Take the mounting rack/pole bracket combination to the pole.
4. Wrap the metal band of the upper bracket around the pole.
5. Insert the free end of the metal band (grooved type) into the slot on the worm screw housing, as shown in [B] of Figure 12. Wind the metal band into the locking device by turning the nut with a flat screwdriver or 8 mm hexagon socket and wrench.

OR

Insert the hook-shaped free end of the band (non-grooved type) into the slot on the worm screw housing. Tighten the worm screw using a flat screwdriver or 8 mm hexagon socket and wrench.

6. When all the slack on the band has been wound in with the locking device, tighten the worm screw to 10 Nm (7.4 lb ft) using a torque socket spanner/wrench and the 8 mm hexagon socket.
7. Fix the lower bracket in the same manner as the upper bracket.

NOTE! Make sure that the three adjacent screw holes are on the upper edge of the bracket block.

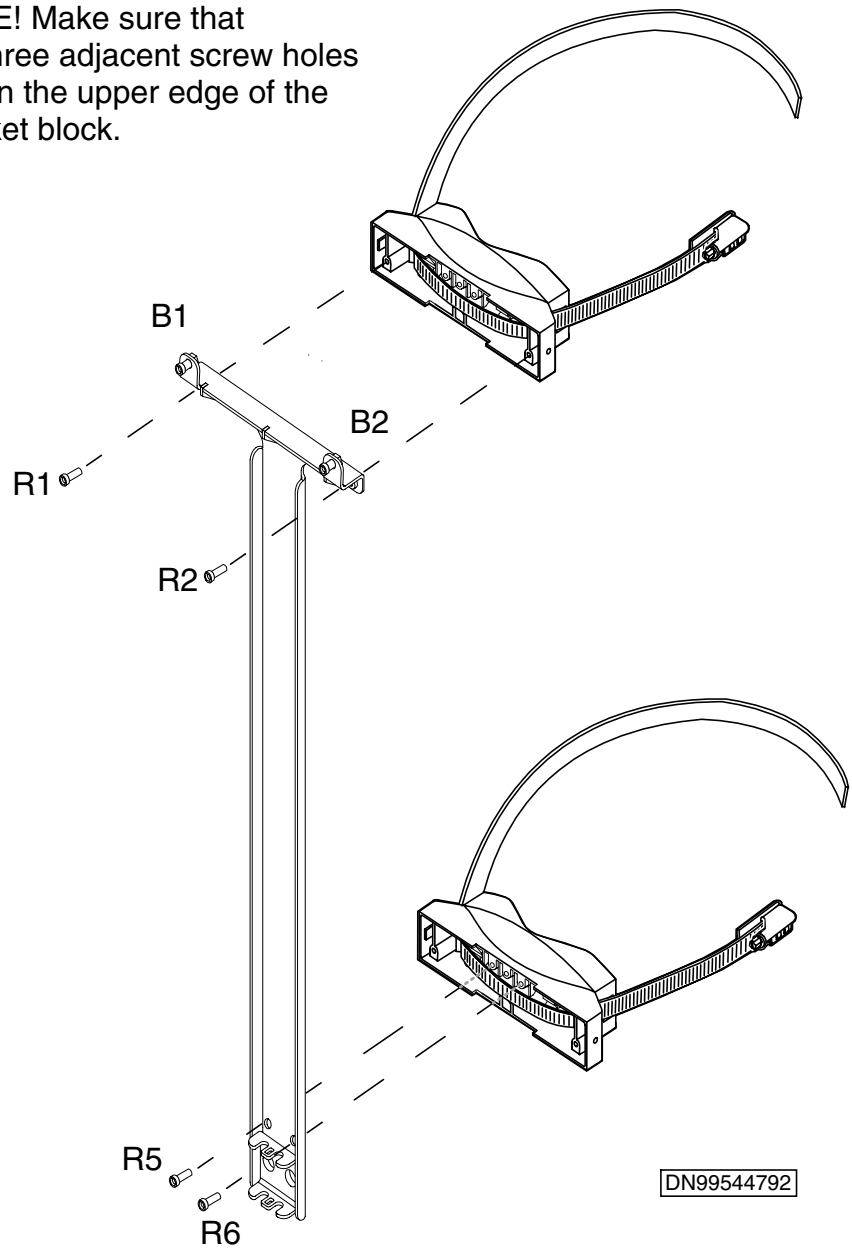

Figure 14. Attaching the mounting rack and the pole brackets



Fixing the BTS to the mounting rack

1. Bring the BTS to the mounting rack and hang it on the upper BTS fixing screws, B1 and B2 in Figure 15. Do not tighten them yet!
2. Position the offset screws on the L-beam (on the back of the cabinet) into the offset screw slots on the lower part of the mounting rack, as shown in the inset illustration in Figure 7.
3. Tighten the upper BTS fixing screws (B1 and B2 in Figure 15) to 5.5 Nm (4.06 lb ft) using a torque driver with a 4 mm Allen bit.
4. Tighten the offset screws on the L-beam from the underside. Use a torque socket spanner/wrench with a 6 mm Allen bit to tighten to 12 Nm (8.85 lb ft).
5. If you have removed any units, proceed to Chapter 7. If you have not removed any units proceed directly to Chapter 8.

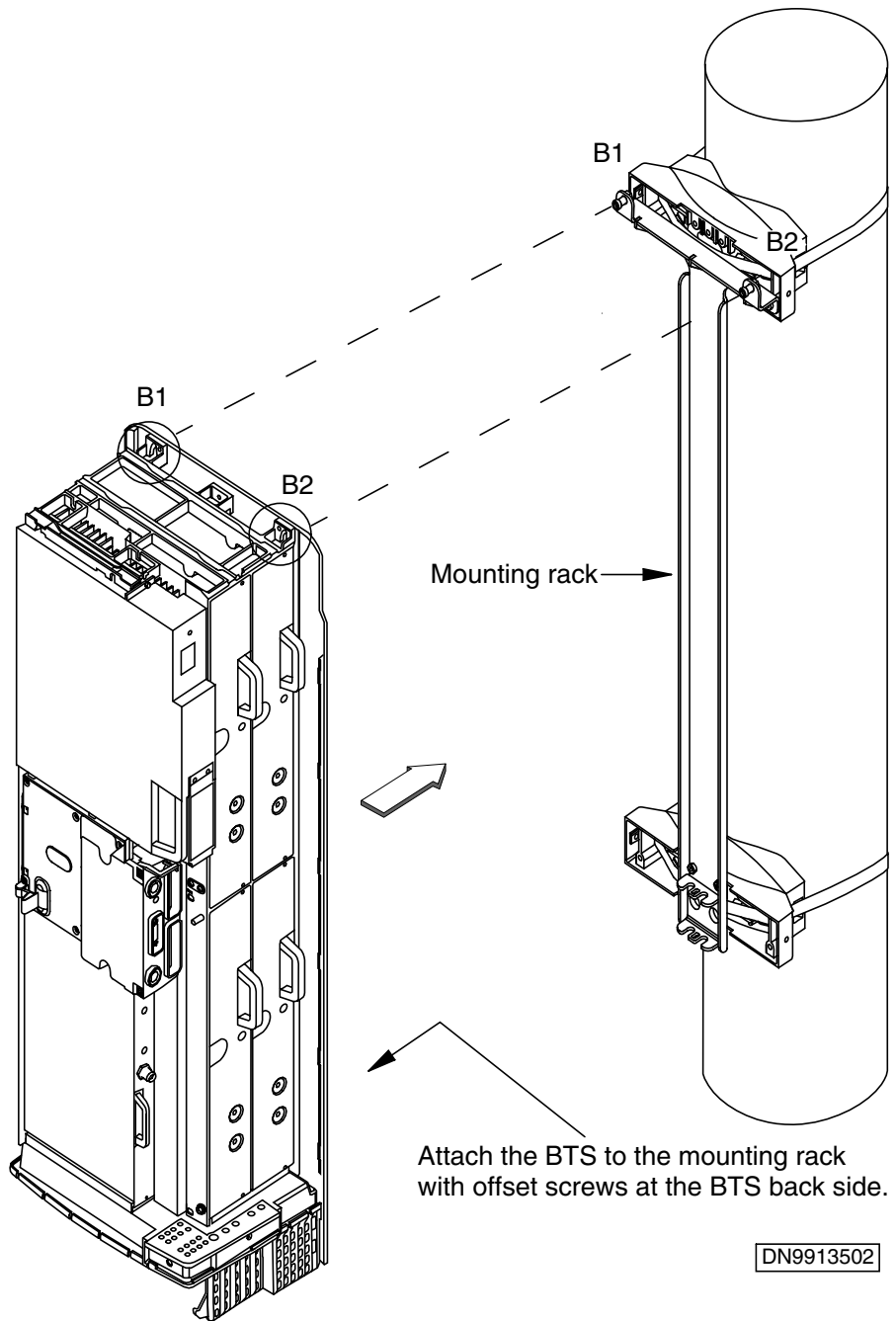

Figure 15. Pole mounting with large-pole mounting kit

7

Reinstalling the units

If any units have been removed from the BTS, they can be reinstalled in any order.

Note

If you have removed any units from the BTS, be sure to install the grounding cable before reinstalling the units. Refer to the grounding cabling instructions in Section 8.2.



Caution

Always use the antistatic wrist strap when removing or installing the units. For more information on electro-static discharge protection, refer to *Nokia MetroSite EDGE Base Station: Warnings and Cautions*. The wrist strap and the connection point are shown in Figure 3.



Reinstalling units

1. Slide the unit into the appropriate slot (see Figure 4).
2. Press the unit carefully against the connectors on the backplane. Do not use excessive force!
3. Fix and tighten the unit retaining screws. Use a torque driver with a T10 Torx bit to tighten to 1.5 Nm (1.11 lb ft).

Note

Shield unit fixing screws may only be tightened to 1.0 Nm (0.74 lb ft).



Caution

In order to ensure proper weather shielding, all unit retaining screws must be tightened.

8

Cabinet cabling

This document assumes that you are using the ready-made cables supplied by Nokia, or that all cables have been prefabricated before starting the cabling of the BTS. For information on the cable types and connectors refer to *Nokia MetroSite EDGE Base Station: Requirements for Installation and Operation*. For the pin configurations refer to *Nokia MetroSite EDGE Base Station: Product Description*.

Note

The connectors on the units' front panels are protected with rubber caps. Remove the caps only from those connectors that will be used for BTS cabling.

8.1 Preparations for cabling



Before starting the cabling, do the following:

1. Displace the sealing strip around the cable entry block. See [A] in Figure 16.
2. Loosen and remove the two Allen screws that keep the cable entry block in place. Use a torque driver with a 4 mm Allen bit. For the location of the screws, see [B] in Figure 16.

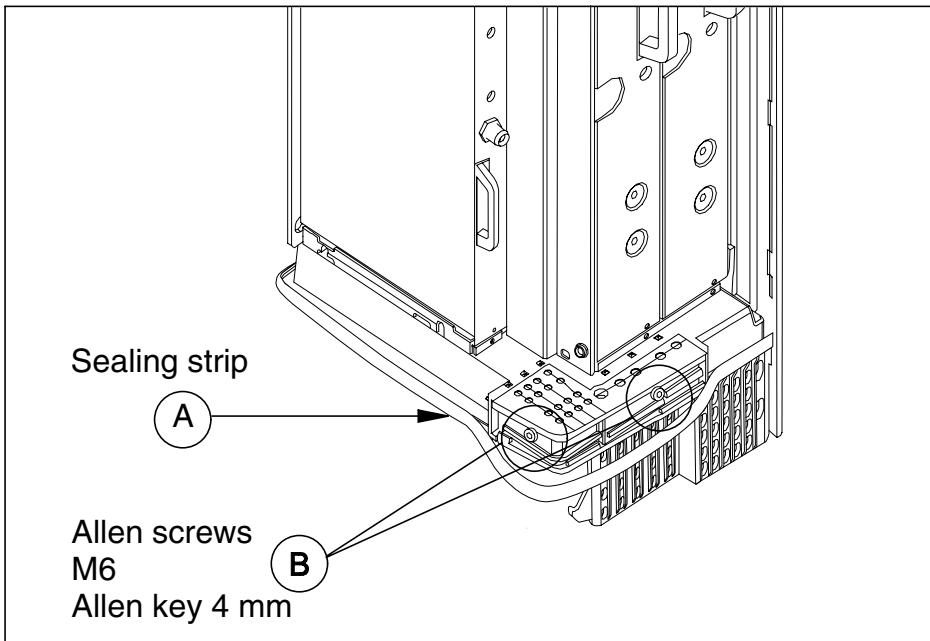

Figure 16. Displacing the sealing strip and removing the cable entry block screws

Note

When the screws are removed, the cable entry block can be split apart at appropriate places for routing the cables through the cable holes. For routing the cables through the block, see Figure 17.

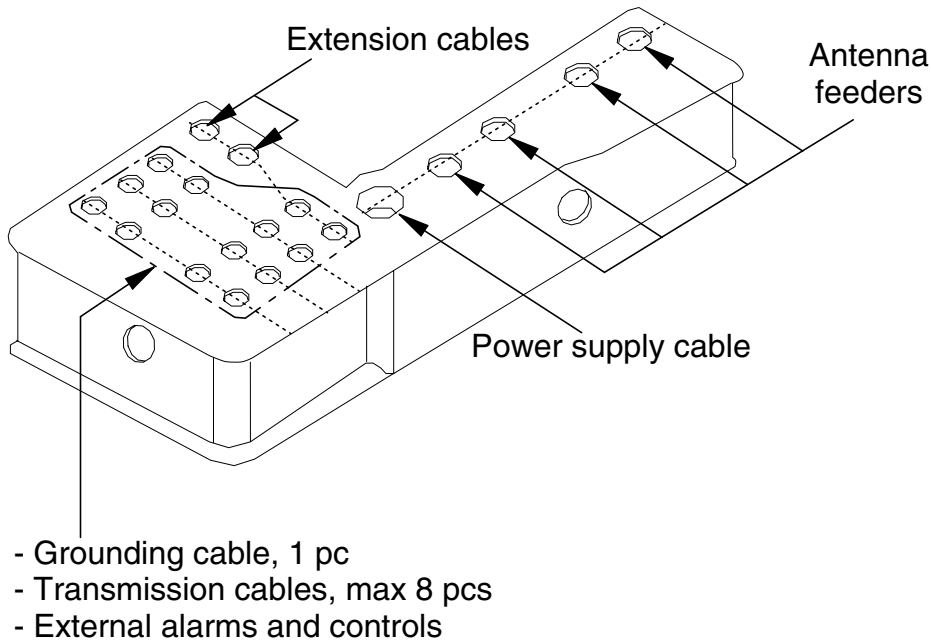

Figure 17. Cable routing through the cable entry block

8.2 Grounding



WARNING

To guarantee the safety of service personnel and other users of the telecommunication network, additional protective grounding is always required as stated in EN 60950, “Safety of information technology equipment, including electrical business equipment.” and UL 1950 3rd edition. The additional external ground cable is connected to the grounding connector.

Ensure that the ground connection is secure and non-removable.

There are two alternative grounding connectors in the BTS chassis (see Figure 18). Depending on the local regulations, choose the appropriate connector for connecting the grounding cable to the chassis. Note that the grounding cable in alternative 2 must be fitted with a cable shoe.

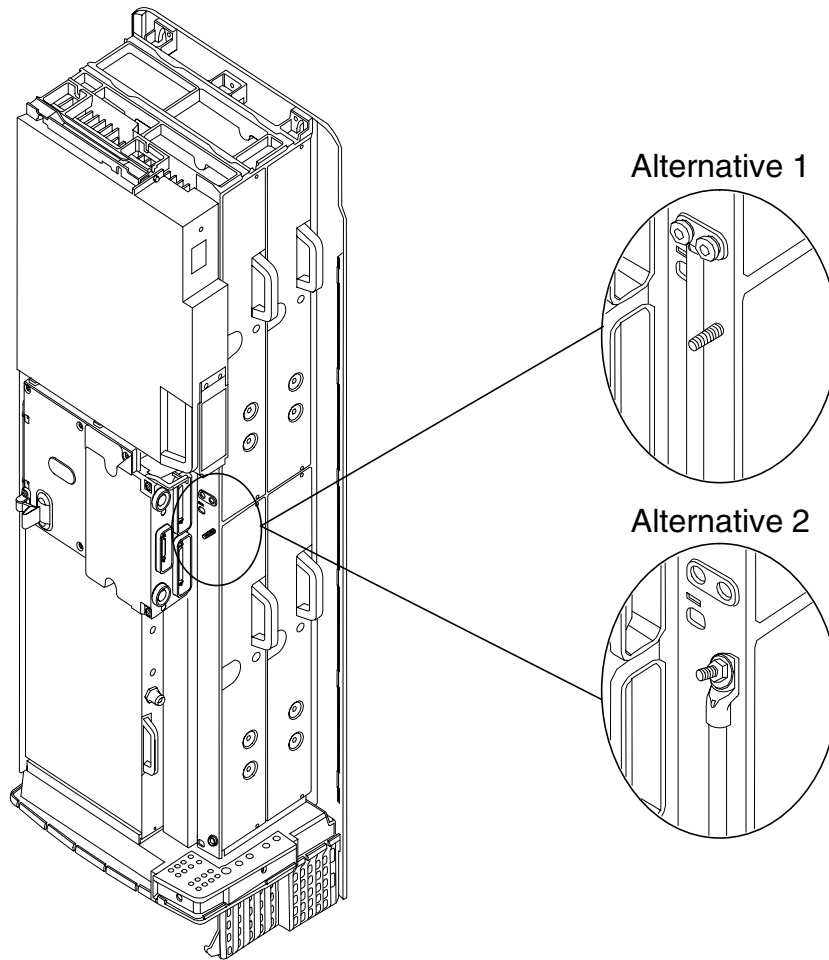

Figure 18. Grounding connector alternatives



Connecting the ground wire to the connector, alternative 1

1. Loosen the two locking screws and washers from the grounding connector using a torque driver with a 4 mm Allen bit.
2. Strip the end of the grounding cable using side-cutting pliers and attach a flat crimp terminal to it. Fix the terminal to the cable with a crimping tool.
3. Insert the crimp terminal between the cabinet and the washer. Tighten the screws.

4. Make sure that the grounding cable is correctly positioned and that the screws are securely tightened.



Connecting the ground wire to the connector, alternative 2

1. Strip the end of the grounding cable using side-cutting pliers and attach a cable shoe to the cable with a crimping tool.
2. Loosen and remove the locknut from the grounding stud.
3. Place the cable shoe over the grounding stud.
4. Replace the locknut on the stud and tighten with an 8 mm hexagon socket.
5. Make sure that the grounding cable is correctly positioned and that the nut is securely tightened.

8.3 Power supply



WARNING

MAINS VOLTAGE! Follow your national legislation when working with the power supply. The Nokia MetroSite EDGE Base Station must be permanently wired to a disconnect device (such as a circuit breaker), in accordance with current local and national wiring standards.

The following warning applies to the AC power supply. The protective ground wire can only be used for protective conductor installations. Using the protective ground conductor for other purpose is dangerous to life.

Ensure that the ground connection is established before the power outlet is connected to the BTS.



WARNING

The mains power supply must be switched OFF before starting installation of the power supply cable!



Connecting the power supply cable to the power supply unit

1. Make sure that the site's mains power supply is switched OFF and that the switch on the power supply unit is in the stand-by position.
2. Open the connector shield by loosening the retaining screws with a torque driver and a T10 Torx bit (see Figure 19).
3. Open up the rubber sealing piece and route the power supply cable through it. Close the sealing piece.

Note

DC power can be fed in with three separate conductors. In this case, reverse the rubber sealing piece so that the three small recesses are facing each other and form three small holes (see Figure 19). Use the three holes for routing the conductor cables.

4. Connect the power supply cable to the power connector in the power supply unit.
5. Close the power supply connector shield and tighten the screws.

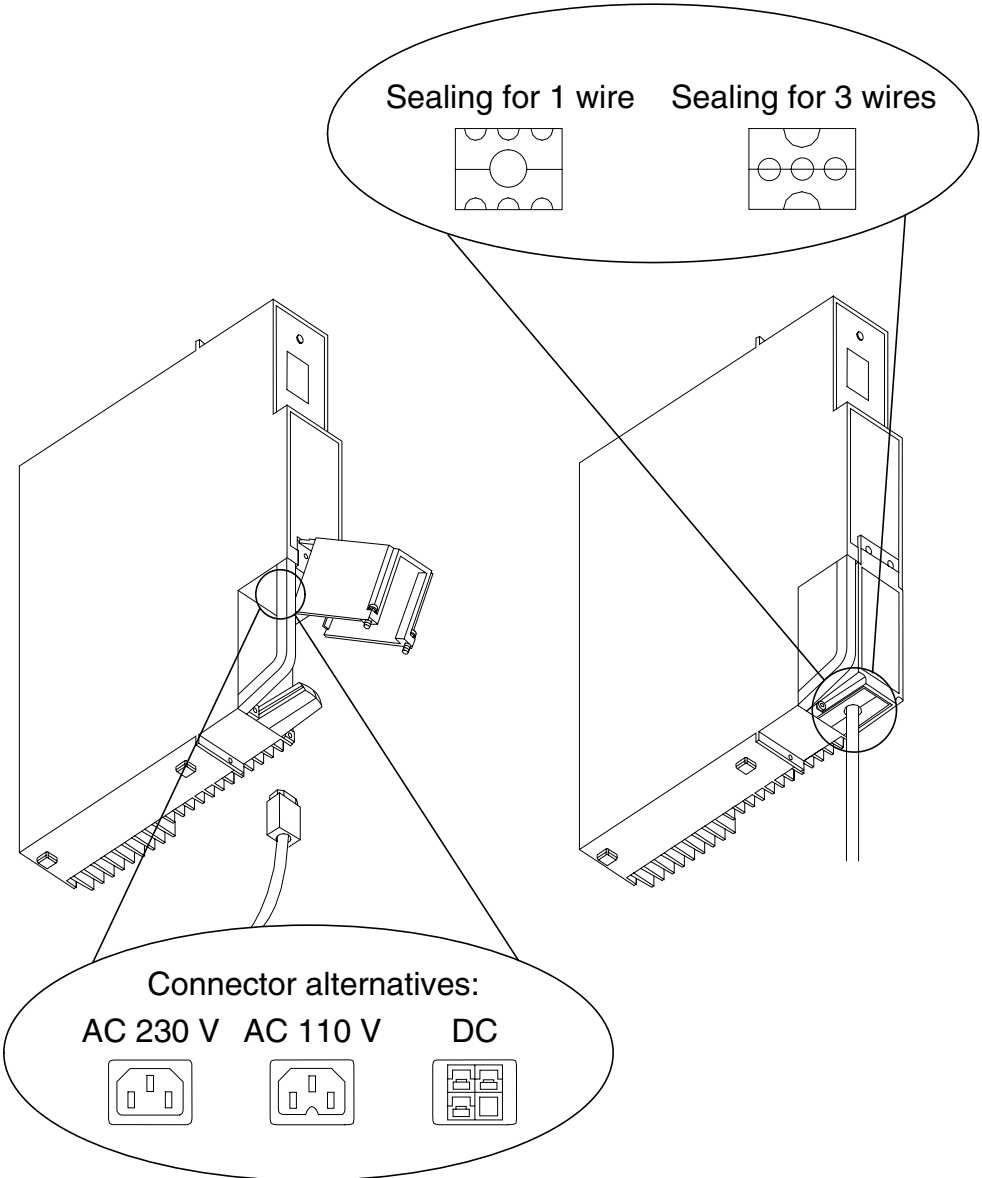

Figure 19. Power supply unit and power connector alternatives

8.4 Transmission unit

The cabling of the transmission unit is dependent on the transmission unit type. This section instructs how to cable each transmission unit type.

Note

It is a good procedure to label the TX and RX cables when you connect them to the transmission unit. This makes any subsequent maintenance or upgrade procedures easier.

8.4.1 FC E1/T1 transmission unit

Either separate 75 Ω RX and TX connectors (type BT-43), or one 120/100 Ω TX/RX connector (type TQ) can be used.

Note

The 75 Ω TX and RX connectors are connected to each other with a grounding bridge (see Figure 20). If the grounding bridge is removed, the grounding of the RX connector's outer conduct changes from direct grounding to capacitive grounding.

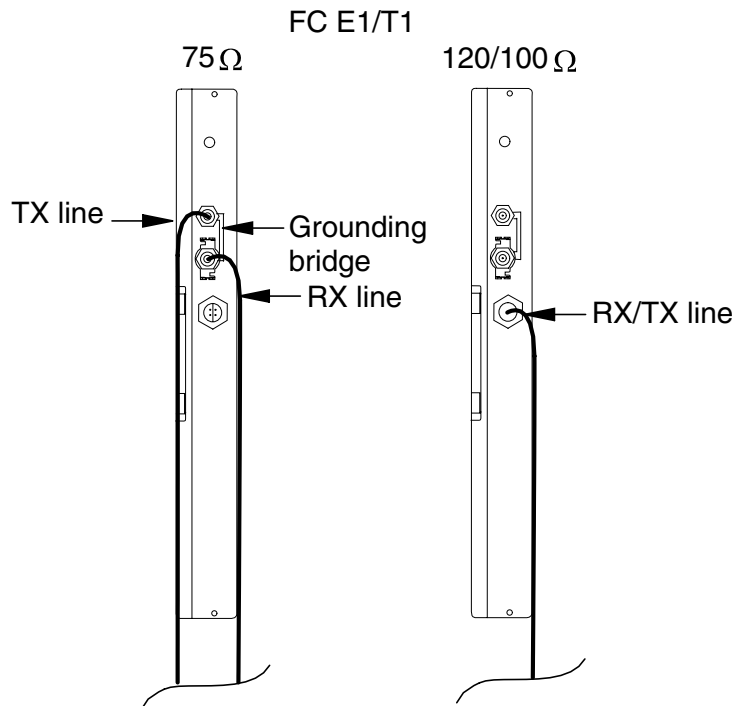

Figure 20. Cabling alternatives for the FC E1/T1 transmission unit



Cabling an FC E1/T1 75 Ω transmission unit

1. If you want to remove the grounding bridge (see Figure 20), use a 10 mm hexagon socket to loosen both connectors and pull out the bridge. Re-tighten the connectors.
2. Connect the connector of the received (RX) signal line to the 75 Ω RX connector on the FC E1/T1 front panel.
3. Connect the connector of the transmitted (TX) signal line to the 75 Ω TX connector on the FC E1/T1 front panel.



Cabling an FC E1/T1 120/100 Ω transmission unit

- Connect the connector of TX/RX signal line to the 100/120 Ω TX/RX connector on the FC E1/T1 front panel (see Figure 20). Tighten the connector nut properly.

8.4.2 FXC E1 transmission unit

The FXC E1 has four pairs of 75 Ω connectors (type BT-43). Each pair forms a transmission interface (IF). The upper connector is always the TX connector of any given transmission interface. The lower connector is always the RX connector of any given transmission interface (see Figure 21).

Note

The 75 Ω TX and RX connectors are connected to each other with a grounding bridge (see Figure 21). If the grounding bridge is removed, the grounding of the RX connector's outer conduct changes from direct grounding to capacitive grounding.

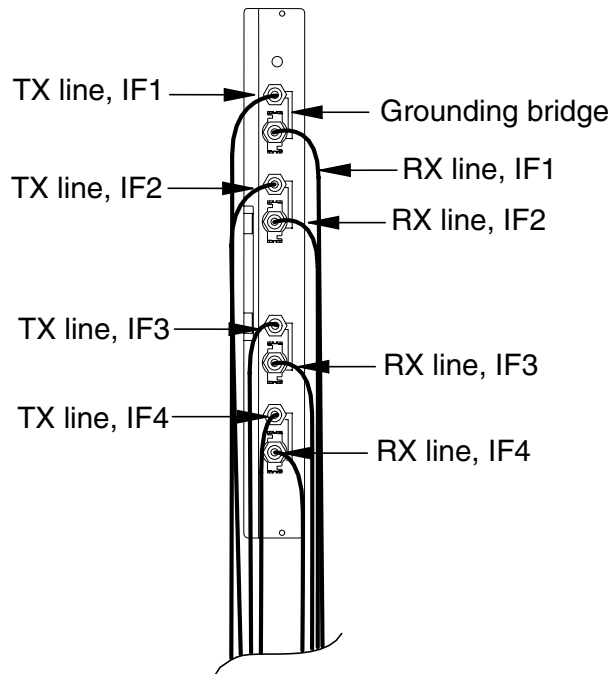

Figure 21. Cabling of the FXC E1 transmission unit



Cabling an FXC E1 transmission unit

1. If you want to remove the grounding bridge (see Figure 21), use a 10 mm hexagon socket to loosen both connectors and pull out the bridge. Retighten the connectors.
2. Connect the connector of the received (RX) signal line to the 75 Ω RX connector on IF1.
3. Connect the connector of the transmitted (TX) signal line to the 75 Ω TX connector on IF1.
4. Cable the other IFs in the same manner (see Figure 21).

8.4.3 FXC E1/T1 transmission unit

FXC E1/T1 has four 100/120 Ω TX/RX connectors (type TQ).

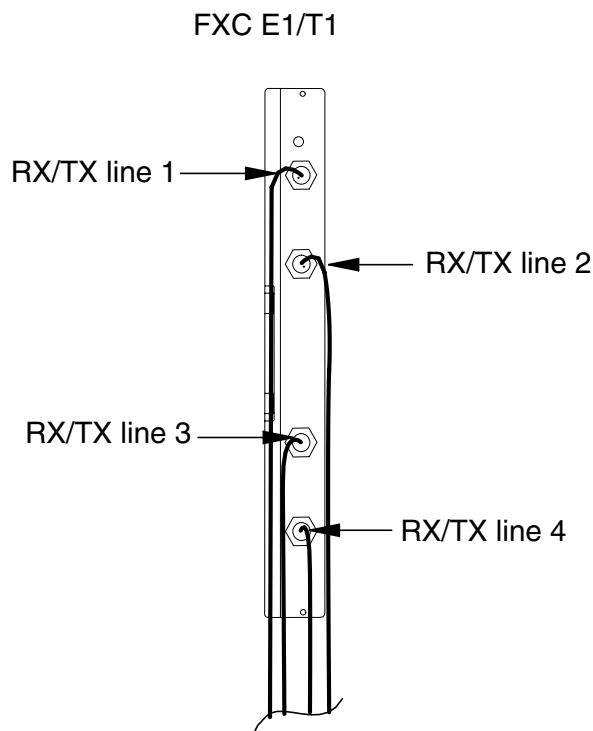

Figure 22. Cabling of the FXC E1/T1 transmission unit



Cabling an FXC E1/T1 transmission unit

- Connect the connectors of the TX/RX signal lines to the 100/120 Ω TX/RX connectors on the FXC E1/T1 front panel (see Figure 22). Tighten the connector nut properly.

8.4.4 FXC RRI transmission unit

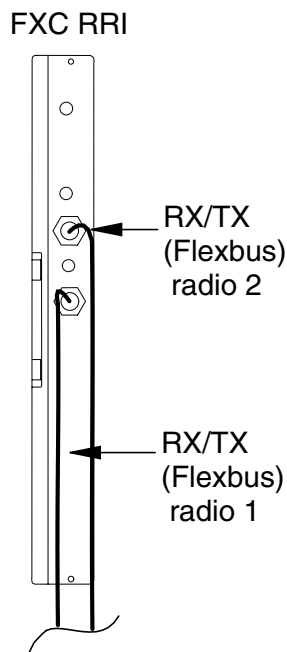

Figure 23. Cabling of the FXC RRI transmission unit



Cabling the FXC RRI transmission unit

- Connect the RX/TX (Flexbus) cable from the radio outdoor unit to the TNC connector(s) on the FXC RRI transmission unit (see Figure 23).

8.5 Interface unit

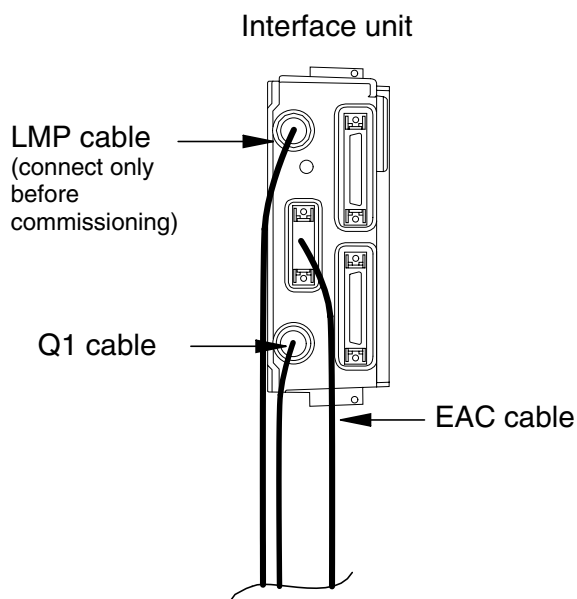

Figure 24. Cabling of the interface unit

Note

When you have connected the cables, push the rubber seals onto the connectors.



Cabling the interface unit

1. Connect the external alarms and controls cable to the EAC connector (26-pin, mini-D connector).

2. Connect the Q1 cable to the Q1 connector (type TQ) on the interface unit.

Note

Only connect the LMP cable from your MetroSite BTS Manager PC to the LMP connector (BQ) just before starting the commissioning.

Note

The extension interface connectors are not used yet.

8.6 Transceiver units (TRXs)

Diversity cables and antenna feeders are connected to the TRXs. See also *Nokia MetroSite EDGE Base Station: Product Description*.



Cabling the TRXs

1. Disconnect the diversity cables from the SMA type connectors on the TRXs (if needed).
2. Reconnect the diversity cables to form the desired diversity configuration. Examples of different sectoring alternatives and their diversity cabling are presented in Figure 25.



Caution

Diversity cables may only be connected between TRXs that belong to the same sector!

3. Connect the antenna feeders to the N-type connectors on the TRXs according to the sectoring solution planned.
-

Note

The diversity cabling solution is always dependent on the antenna solution.

- Use a torque spanner/wrench for tightening the antenna diversity cables. Tighten the SMA type connectors to 1 Nm (0.74 lb ft).

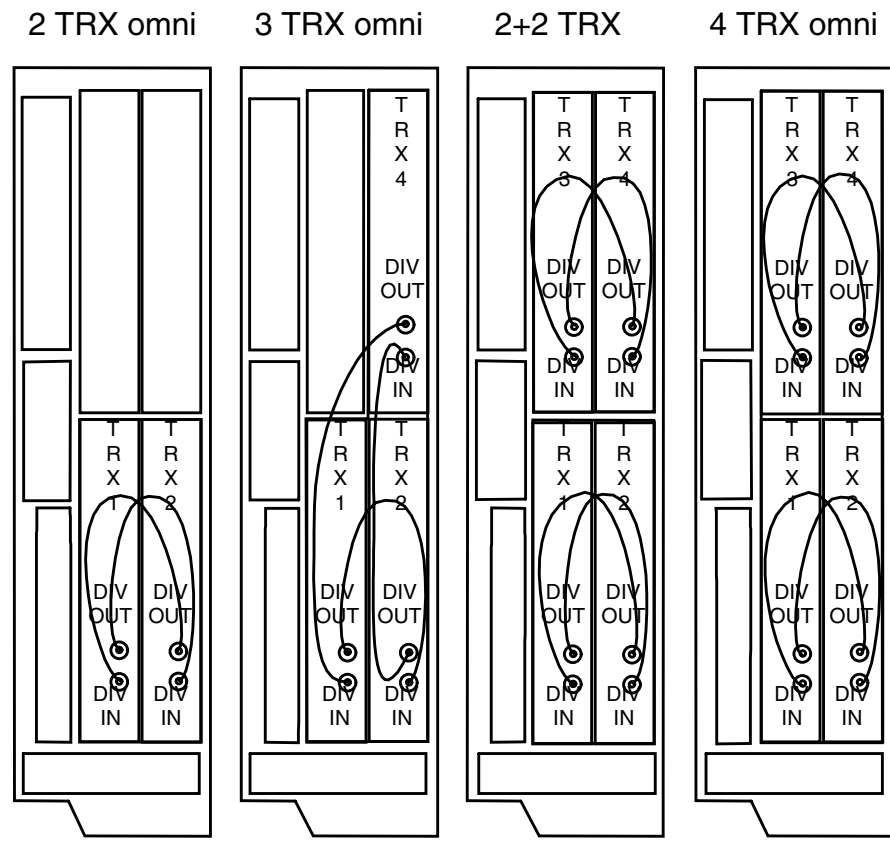

Possible antenna solutions

- | | | | |
|---|---|--|--|
| <ul style="list-style-type: none"> - 2 single port antennas - 1 dual port antenna | <ul style="list-style-type: none"> - 1 dual port and 1 single port antenna - 3 single port antennas | <ul style="list-style-type: none"> - 2 dual port antennas - 4 single port antennas | <ul style="list-style-type: none"> - 2 dual port antennas - 4 single port antennas |
|---|---|--|--|

Figure 25. Examples of diversity cabling alternatives

8.7 Completing the cabling



Completing the cabling procedure

1. Route the cables through the opened cable entry block, as presented earlier in Figure 17.
2. Close the cable entry block with the two Allen screws. Use a torque driver with a 4 mm Allen bit.
3. Replace the sealing strip around the cable entry block.
4. Route the antenna feeder cables and power supply cable to the front of the perforated plastic panel (see [1] in Figure 26). Fix the cables to the perforated panel with cable ties. Use side-cutting pliers to cut off the extruding parts of the cable ties.
5. Route the transmission cables, the grounding cable and the cables coming from the interface unit behind the perforated plastic panel at the lower edge of the BTS (see [2] in Figure 26). Fix the cables to the perforated panel with at least two cable ties. Use side-cutting pliers to cut off the extruding parts of the cable ties.
6. Attach the cable cover support on the grips at the far end of the perforated panel (see [A] in Figure 26).
7. Push the cables towards the cable cover support at the far end of the perforated panel.
8. Place the cable cover onto the hook at the near end of the perforated panel. Align it to the recesses on the cable cover support and slide it downwards until it locks to the cable cover support (see [B] in Figure 26).

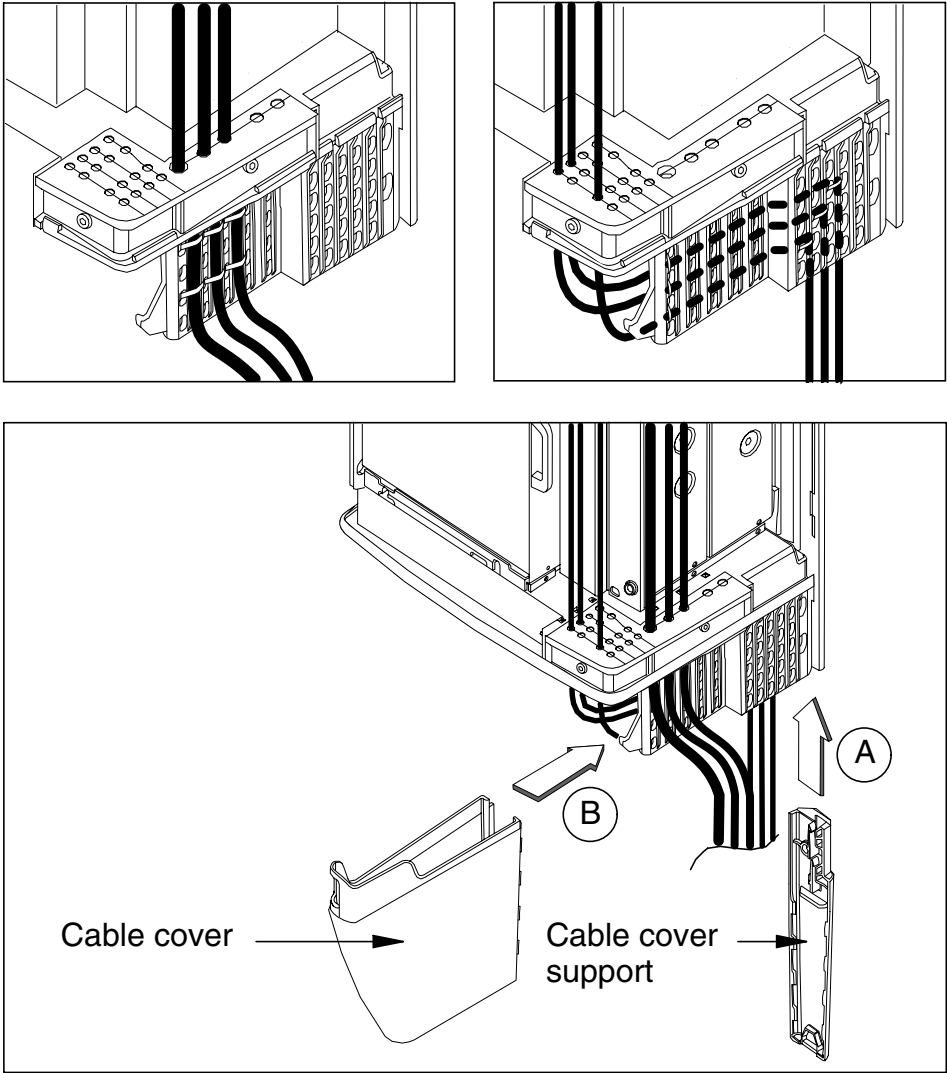

Figure 26. Routing the cables and closing the cable cover

9

Completing the installation

With the BTS safely fixed to a wall or a pole, commissioning can be started. Commissioning can be left to a later stage if there are no qualified personnel on the site during installation. To complete the installation, the BTS cover is fitted to the chassis and the BTS cabinet is locked.



Commissioning the BTS

1. Switch the BTS power ON.
2. Connect the LMP cable from the MetroSite BTS Manager PC to the LMP connector on the interface unit.
3. Proceed to the BTS commissioning tasks. Refer to *Nokia MetroSite EDGE Base Station: Commissioning*.



Fitting the cover and locking the cabinet

1. Bring the BTS cover to the BTS chassis (see Figure 27). Attach the safety strap to the fixing point provided under the top of the cover.
2. Make sure that the cover is secured with the safety strap (see Figure 27).
3. Place the cover over the cabinet and align the locking hooks on the cover to the locking rail on the chassis. Push the cover into the chassis and pull downwards to lock the hooks firmly into the rail.
4. Check that the cover is firmly secured by pushing the cover from the sides.
5. Lock the cabinet with the key.
6. Clean the site. Recycle any applicable material.

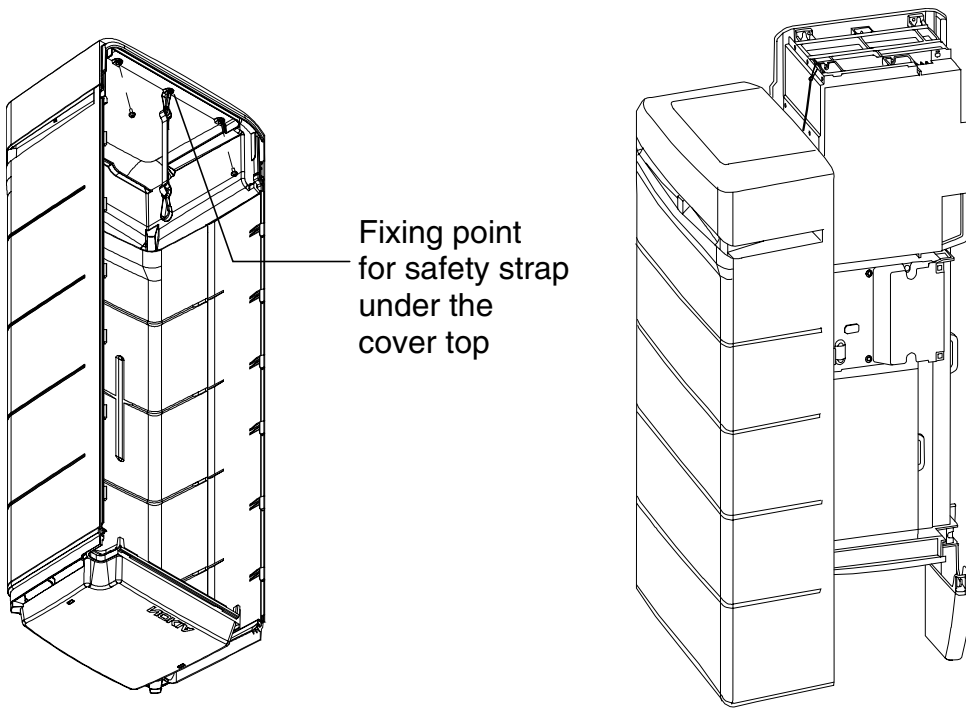

Figure 27. Hanging the BTS cover

Index

A

AC power warnings 55
antenna solutions 64
antistatic wrist strap 25, 49
assembling pole brackets 36, 43

B

band length for pole mounting 41, 43
bracket blocks for pole mounting
 back block 35
 front block 35

C

cabinet installation 29
cable cover 66
cable entry block 52
cables
 antenna feeders 52
 extension 52
 external alarms and controls 52
 grounding 52
 power supply 52
 transmission 52
cabling
 antenna feeders 64
 diversity cables 64
 grounding 53
 interface unit 63
 power supply 55
 transmission unit 58
 TRX unit 64
capacitive grounding 58
cardboard template 30
commissioning 69
completing the cabling 66
cover 69

D

DC power 56
delivery contents 21
dimensions
 mounting rack 30
 pole diameter 35
 wall space 32
direct grounding 58
diversity cabling alternatives 64

E

EAC connector 63
electro-static discharge (ESD) protection 25, 49

F

FC E1/T1 58
FXC E1 60
FXC E1/T1 61
FXC RRI 62

G

grounding 53
grounding bridge 58

I

installing
 BTS onto a pole 37
 BTS onto a wall 32
 BTS onto the mounting rack 38, 46
 cabinet 29
 mounting rack onto a pole 44
 pole brackets onto a pole 44
 units 49
interface unit
 cabling 63

K

key for BTS cabinet lock 20

L

L-beam 34
LMP connector 64
locking device 43

M

mounting kit 35
mounting kit for pole mounting 41
mounting rack 29, 34
mounting rack installation 37, 44

O

offset screws 34

P

- parts for installation 16, 30
- pole bracket assembly 36, 43
- pole bracket installation 44
- pole diameter 35, 41, 43
- pole mounting 34
- pole mounting kit 22
- power supply connectors 56
- power supply unit
 - cabling 55
- preparations
 - cabling 51

Q

- Q1 connector 64

R

- removing units 25

S

- safety strap 69
- sealing strip 51
- sectoring solutions 64
- shield units 21, 25, 49
- site requirements 15
- SMA type connectors 64

T

- template for wall mounting 30
- tools for installation 16
- transceiver unit (TRX)
 - cabling 64
- transmission unit
 - cabling 58
- transportation package 19

U

- unit installation 49
- unit removal 25
- unpacking the delivery 19

W

- wall mounting 32