

FCC Part 15 Subpart C Requirement
and Industry Canada RSS-210
Measurement and Test Report



For

Sanwa Electronic Instrument Co., Ltd

1-2-50, Yoshida Honmachi, Higashi-Osaka, Osaka 578-0982, Japan

FCC ID: L7392010
IC: 7377A-92010

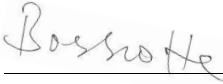
February 20, 2014

This Report Concerns: <input checked="" type="checkbox"/> Original Report	Equipment Type: 2.4GHz Radio Control System
Tested By:  Bossco He (Test Engineer)	
Report Number:	SE14B-600FI
Test Date:	February 08 to 19, 2014
Reviewed By: 	Karbon Y.Chung (Senior Manager)
Prepared By:	S&E Technologies Laboratory Ltd Room 407, Block A Shennan Garden, Hi-Tech Industrial Park, Shenzhen 518057, P.R. China. Tel: 86-755-26636573, 26630631 Fax: 86-755-26630557

Note: This test report is limited to the above client company and the product model only.
It may not be duplicated without prior written consent of S&E Technologies
Laboratory Ltd.

Table of Contents

- 1- TEST RESULT CERTIFICATION 3**
- 2- EUT DESCRIPTION 4**
- 3-TEST SYSTEM 5**
 - 3.1 TEST MODE 5
 - 3.2 TEST SETUP DIAGRAM 6
 - 3.3 DESCRIPTION OF TEST AUXILIARY EQUIPMENTS 7
 - 3.4 BLOCK DIAGRAM OF EUT SYSTEM..... 7
 - 3.5 LIST OF CABLES 7
- 4- TEST EQUIPMENT AND CALIBRATION 8**
- 5- LABORATORY ACCREDITATIONS AND MEASUREMENT UNCERTAINTY 9**
 - 5.1 LABORATORY ACCREDITATION..... 9
 - 5.2 MEASUREMENT UNCERTAINTY 9
- 6- TECHNICAL REQUIREMENTS AND RESULTS..... 10**
 - 6.1 CARRIER FREQUENCY SEPARATION MEASUREMENT..... 10
 - 6.2 NUMBER OF HOPPING FREQUENCIES MEASUREMENT 12
 - 6.3 TIME OF OCCUPY (DWELL TIME) MEASUREMENT 14
 - 6.4 PEAK OUTPUT POWER MEASUREMENT..... 18
 - 6.5 BAND EDGE OF CONDUCTED EMISSION AND SPURIOUS RF CONDUCTED EMISSIONS 22
 - 6.6 SPURIOUS RADIATED EMISSION MEASUREMENT 28
 - 6.7 CONDUCTED EMISSION MEASUREMENT 34
 - 6.8 BAND EDGE AND RESTRICTED BAND OF RADIATED EMISSION MEASUREMENT 36
 - 6.9 99% BANDWIDTH MEASUREMENT..... 43
 - 6.10 RF EXPOSURE 46
 - 6.11 ANTENNA REQUIREMENT 47

1- Test Result Certification

Applicant: Sanwa Electronic Instrument Co., Ltd
 1-2-50, Yoshida Honmachi, Higashi-Osaka,
 Osaka 578-0982, Japan

Equipment Under Test: 2.4GHz Radio Control System

Trade Mark: **SANWA**

Model Number.: 92010

Type of Modulation: FHSS

Number of Channels: 76

Channel Separation: 1MHz

Operation Frequency: Mode FH4: 2403-2478MHz
 Mode FH4FT: 2410-2450MHz
Note: The above operation modes can be mutually switched to each other by matched transmitters.

Antenna Designation: Non-user replaceable (fixed)

Power Supply: DC6.0V [4*1.5V "AA" size battery pack]

Date of Test: February 08 to 19, 2014

Applicable Standards	
Standard	Test Result
FCC 47 CFR Part 15 Subpart C: 2012, §15.247 Industry Canada: RSS-210 issue 8: 2010, Annex 8 Industry Canada: RSS-Gen issue 3: 2010	No non-compliance noted

We hereby certify that:

The above equipment was tested at laboratory of Guangdong Galanz Enterprises Co., Ltd, 25 South Ronggui Rd, Shunde, Foshan, Guangdong, China. The test data, data evaluation, test procedures, and equipment configurations shown in this report were made in accordance with the procedures given in ANSI C63.4: 2003 and Public Notice DA00-705. The energy emitted by the sample EUT tested as described in this report is in compliance with conducted and radiated emission limits of FCC Rules Part 15C: 2012, §15.247 and RSS-210 Issue 8, Annex 8.

The test results of this report relate only to the tested sample identified in this report.

2- EUT Description

Product Name:	2.4GHz Radio Control System
Trade Mark:	SANWA
Model Number:	92010
Model Difference:	N/A
Type of Modulation::	FHSS
Number of Channels:	76
Channel Separation:	1MHz
Power Supply:	6.0V DC power from 4*1.5V "AA" size batteries
Frequency Range:	2403 ~2478 MHz
Antenna Designation:	Non-user replaceable (fixed)

Remark: This submittal(s) test report is intended for FCC ID: L7392010, IC: 7377A-92010 filing to comply with Section 15.247 of the FCC Part 15, Subpart C Rules and RSS-210 Issue 8, Annex 8.

3-Test System

3.1 Test Mode

The compliance test was performed under test modes:

Mode 1: Transmitting at 2403MHz without hopping.

Mode 2: Transmitting at 2442MHz without hopping.

Mode 3: Transmitting at 2478MHz without hopping.

Mode 4: Transmitting with hopping.

The EUT is designed both of horizontally placed and vertically placed. In radiated emission measurement, each condition was conducted.

As a result, the below operation that produce the maximum emission were reported.

- a) Carrier Frequency Separation measurement ---Mode 4
- b) Number of Hopping Frequencies measurement --- Mode 4
- c) Time of Occupancy measurement --- Mode 4
- d) Peak Output Power measurement --- Mode 1, Mode 2, Mode 3
- e) Band Edge of RF Conducted measurement --- Mode 1, Mode 3 and Mode 4
- f) Radiated Emission measurement --- Mode 1, Mode 2, Mode 3
- g) Band Edge and Restricted Band of Radiated Emission measurement--- Mode 1, Mode 3
- h) 99% Bandwidth measurement --- Mode 1, Mode 2, Mode 3

3.2 Test Setup Diagram

- . Carrier Frequency Separation
- . Number of Hopping Frequencies
- . Time of Occupancy (Dwell Time)
- . Peak Output Power
- . Band Edge of RF Conducted Emission
- . 99% Bandwidth

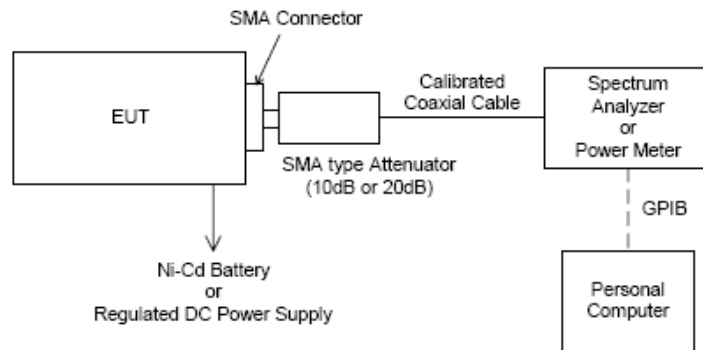

Note: Regulated DC power supply is not used in this report.

. Radiated Emission

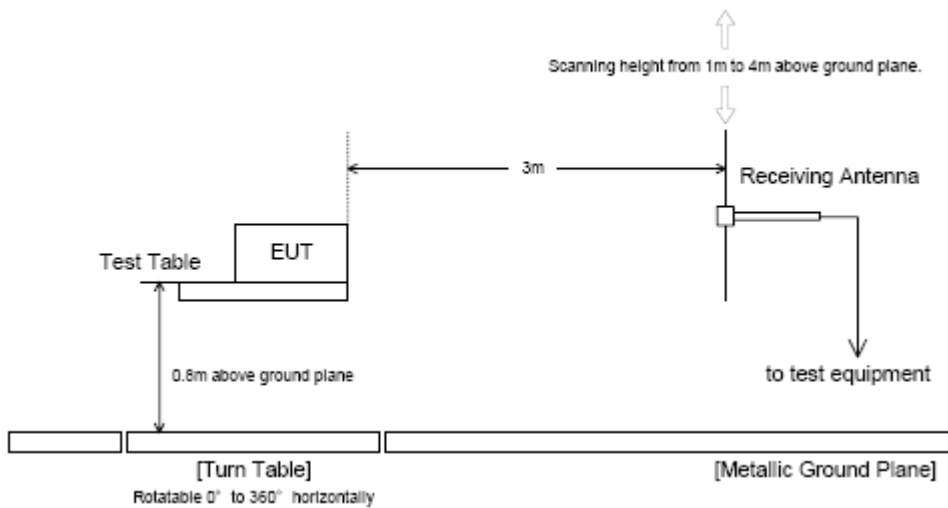

3.3 Description of Test Auxiliary Equipments

Description	Manufacturer	Model No.	Certificate
Transmitter	Sanwa Electronic Instrument Co., Ltd	90481	L73-90481
Servo motor		SRM-102	FCC
Battery box		4xAA	N/A

3.4 Block Diagram of EUT System

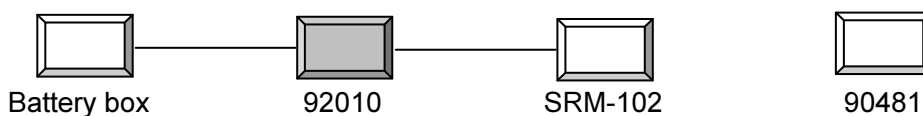

3.5 List of Cables

No	Cable Name	Shielded (Y/N)	Length (m)	Note	Remark
1	Antenna	Y	0.21	/	/

4- Test Equipment and Calibration

Equipment type	Manufacturer	Model	Serial Number	Last Calibration	Calibration Period
Biconilog Antenna	ETS	3142C	00042672	2013/09	1 year
Receiver	SCHAFFNER	SMR4503	11725	2013/07	1 year
Spectrum Analyzer	R/S	FSP30	100755	2013/11	1 year
Double-Ridged-Waveguide Horn Antenna	ETS	3115	6587	2013/08	1 year
Double-Ridged-Waveguide Horn Antenna	ETS	3160	00052486	2013/08	1 year
Amplifier	Agilent	83017A	MY39500438	2013/11	1 year
Band-pass Filter	Micro-Tronic	BRM50702	S/N-030	2013/11	1 year
HF Loop Antenna	TESEQ	HLA6120	26348	2013/10	1 year
Anechoic Chamber	ETS	N/A	N/A	2013/05	1 year

5- Laboratory Accreditations and Measurement Uncertainty

5.1 Laboratory Accreditation

FCC-Registration No.: 580210

Guangdong Galanz Enterprises Co., Ltd EMC Laboratory has been registered and fully described in a report filed with the FCC (Federal Communications Commission). The acceptance letter from the FCC is maintained in our files. Listing date: November 28, 2012.

IC-Registration No.: 8801A

Guangdong Galanz Enterprises Co., Ltd EMC Laboratory has been registered by Certification and Engineering Bureau of Industry Canada for the performance of radiated measurements with Registration No. 7949A on May 03, 2013.

5.2 Measurement Uncertainty

- of +/- 3×10^{-9} for Carrier Frequency Separation Measurement
- of +/- 3×10^{-9} for Number of Hopping Frequencies Measurement
- of +/- 3×10^{-9} for 20dB Bandwidth Measurement
- of +/- 3×10^{-9} for Time of Occupancy (Dwell time) Measurement
- of +/- 0.8 dB for Peak Output Power Measurement
- of +/- 0.8 dB for Band Edge RF Conducted Measurement
- of +/- 0.8 dB for Spurious RF Conducted Emission Measurement
- of +/- 0.8 dB for Power Density
- of +/- 4.8 dB for Radiated Emissions
- of +/- 2.3 dB for Conducted Emissions

6- Technical Requirements and Results

6.1 Carrier Frequency Separation Measurement

Applicable Standard:

According to §15.247(a)(1), frequency hopping systems shall have hopping channel carrier frequencies separated by a minimum of 25 kHz or the 20 dB bandwidth of the hopping channel, whichever is greater. Alternatively, frequency hopping systems operating in the 2400-2483.5 MHz band may have hopping channel carrier frequencies that are separated by 25 kHz or two-thirds of the 20 dB bandwidth of the hopping channel, whichever is greater

According to RSS 210 issue 8, A8.1(b), frequency hopping systems operating in the 2400-2483.5 MHz band may have hopping channel carrier frequencies that are separated by 25 kHz or two-thirds of the 20dB bandwidth of the hopping channel, whichever is greater.

Test Procedure:

1. Connect the EUT RF output port to spectrum analyzer via calibrated coaxial cable and suitable attenuator (if necessary).
2. Activates the EUT System and execute the software prepared for test, if necessary.
3. To find out the maximum emission condition, the transmitting data rate of EUT is set to maximum data rate.
4. The Spectrums are scanned and allow the trace stabilized.
5. The separation between the peaks of the peaks of adjacent channel were measured by using delta-maker function of the spectrum analyzer

Spectrum analyzer setup conditions:

Frequency span : 2MHz

Resolution bandwidth : 100kHz

Video bandwidth : \cong RBW

Sweep : Auto

Detector function : Peak

Trace mode : Max Hold

Test Result:

Temperature:	20 °C
Humidity:	58%
EUT Operation:	Data transmission with hopping
Test Date:	February 11, 2014

Carrier Frequency Separation [MHz]	Limit [MHz]
1.008	> 0.869
<i>Note: Test plot shown in figure 1 on page 11.</i>	

Figure 1: Channel separation

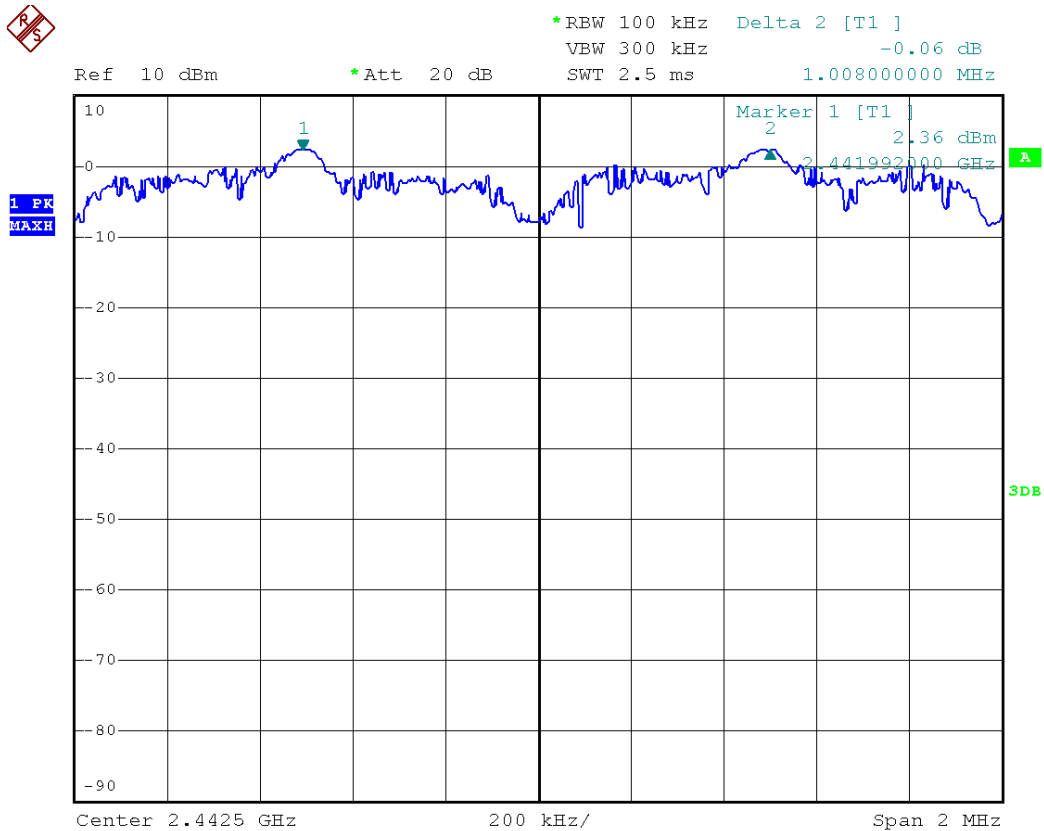

6.2 Number of Hopping Frequencies Measurement

Applicable Standard:

According to §15.247(a)(1)(iii), frequency hopping systems operating in the 2400MHz-2483.5 MHz bands shall use at least 15 hopping frequencies.

According to RSS-210 issue 8, §A8.1(d), frequency hopping systems operating in the 2400-2483.5MHz band shall use at least 15 hopping channels. The average time of occupancy on any channel shall not be greater than 0.4 seconds within a period of 0.4 seconds multiplied by the number of hopping channels employed. Transmissions on particular hopping frequencies may be avoided or suppressed provided that a minimum of 15 hopping channels are used.

Test Procedure:

1. Connect the EUT RF output port to spectrum analyzer via calibrated coaxial cable and suitable attenuator (if necessary).
2. Activates the EUT System and executes the software prepared for test, if necessary.
3. To find out the maximum emission condition, the transmitting data rate of EUT is set to the maximum data rate.
4. The spectrums are scanned and allow the trace to stabilize.
5. The number of hopping frequencies were counted on the spectrum analyzer and recorded.

Spectrum analyzer setup conditions:

Resolution bandwidth :100KHz
 Video bandwidth : \cong RBW
 Sweep : Auto
 Detector function : Peak
 Trace mode : Max Hold

Test Result:

Temperature:	20 °C
Humidity:	58%
EUT Operation:	Data transmission with hopping
Test Date:	February 11, 2014

Number of Hopping Frequencies	Limit [MHz]
76	> 15
<i>Note: Test plots shown in figures 2 to 3 on page 13.</i>	

Figure 2: Number of hopping frequencies

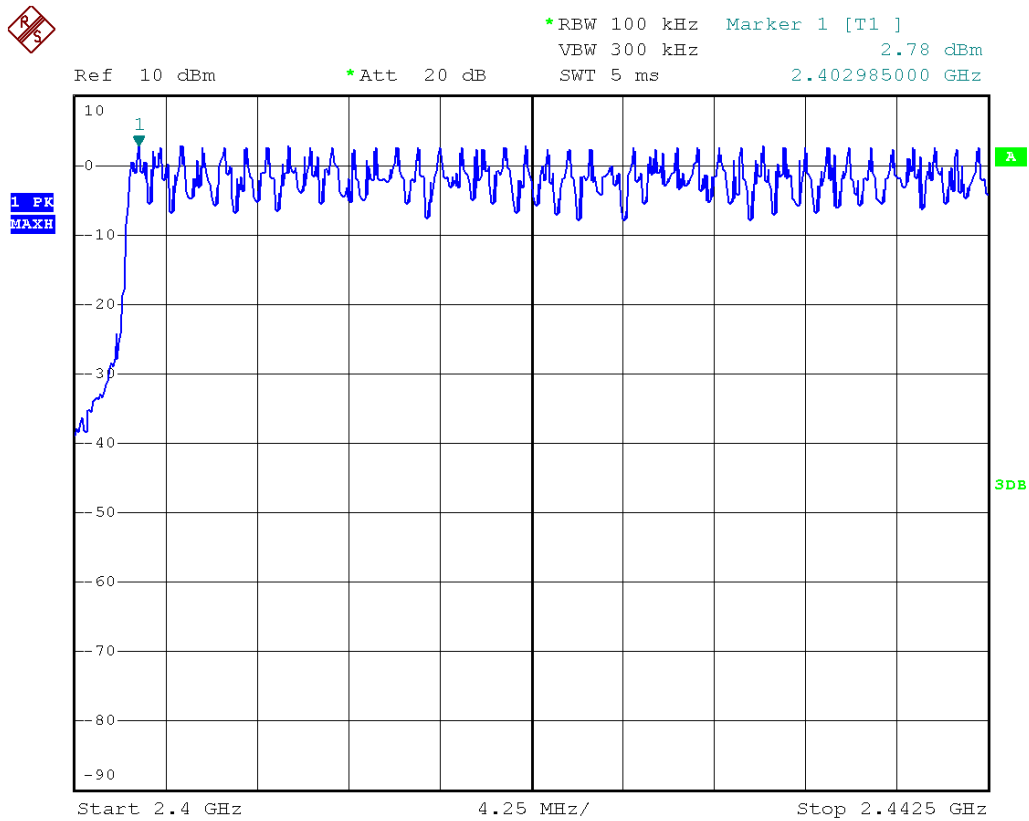
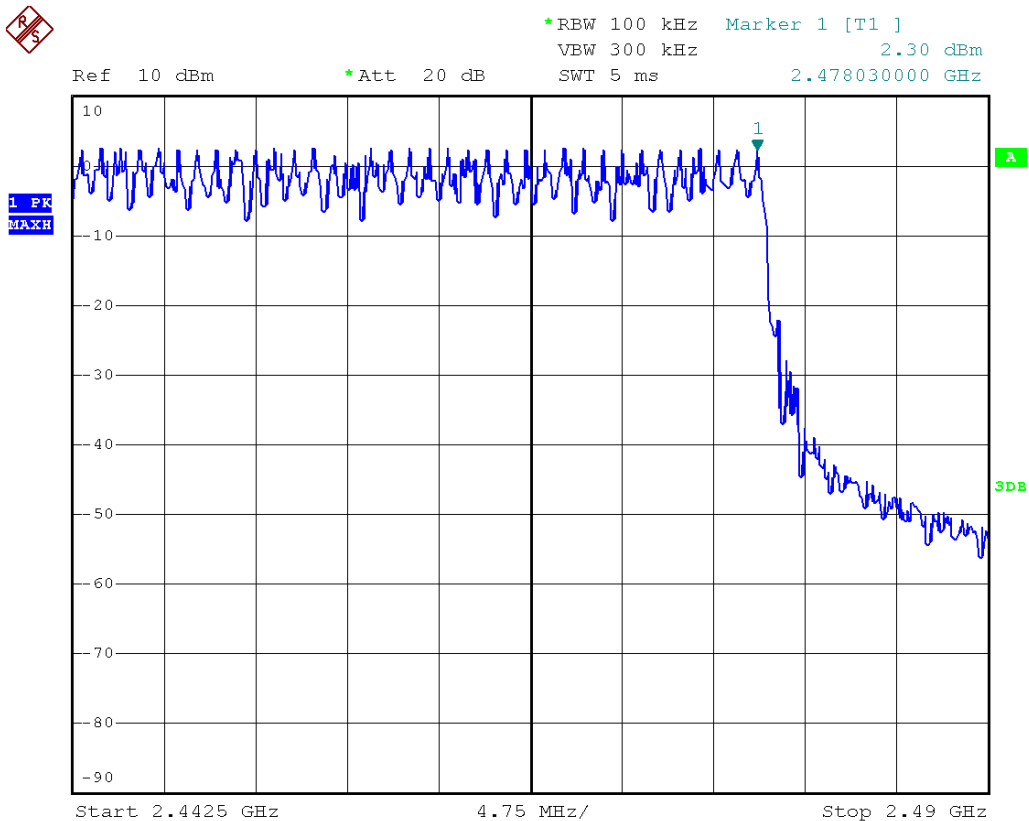

Figure 3: Number of hopping frequencies



6.3 Time of Occupy (Dwell Time) Measurement

Applicable Standard:

According to §15.247(a)(1)(iii), frequency hopping systems operating in the 2400MHz-2483.5 MHz. The average time of occupancy on any frequency shall not greater than 0.4 s within period of 0.4 seconds multiplied by the number of hopping channel employed.

According to RSS-210 issue 8, §A8.1 (d), frequency hopping systems operating in the 2400-2483.5MHz bands shall use at least 15 hopping channels. The average time of occupancy on any channel shall not be greater than 0.4 seconds within a period of 0.4 seconds multiplied by the number of hopping channels employed. Transmissions on particular hopping frequencies may be avoided or suppressed provided that a minimum of 15 hopping channels are used.

Test Procedure:

1. Connect the EUT RF output port to spectrum analyzer via calibrated coaxial cable and suitable attenuator (if necessary).
2. Activates the EUT System and execute the software prepared for test, if necessary.
3. To find out the maximum emission condition, the transmitting data rate of EUT is set to maximum data rate.
4. The span of spectrum analyzer was set to zero (sweep time 30msec). The occupied time at center on a hopping frequency was observed and recorded as "Ton".
5. The spectrums are scanned by using the spectrum analyzer (*1). And the numbers of occupied channel per Nsec (period of 0.4 seconds multiplied by the number of hopping channels employed) were counted by using the delta-marker function of spectrum analyzer and recorded as "N".
6. The dwell time was calculated by $Ton \times N$.

Spectrum analyzer setup conditions:

Frequency span : Zero span

Resolution bandwidth : 1MHz

Video bandwidth : \cong RBW

Sweep : As necessary to capture the entire dwell time per hopping channel.

Detector function : Peak

Trace mode : Max Hold

Test Result:

Temperature:	20°C
Humidity:	56%
EUT Operation:	Data transmission with hopping
Test Date:	February 12, 2014

[ms]Dwell Time	Limit [ms]
0.34ms x 156 = 53.04	< 400
<i>Note: Test plots shown in figures 4 to 6 on pages 16 to 17.</i>	

Figure 4: Duration of one transmission

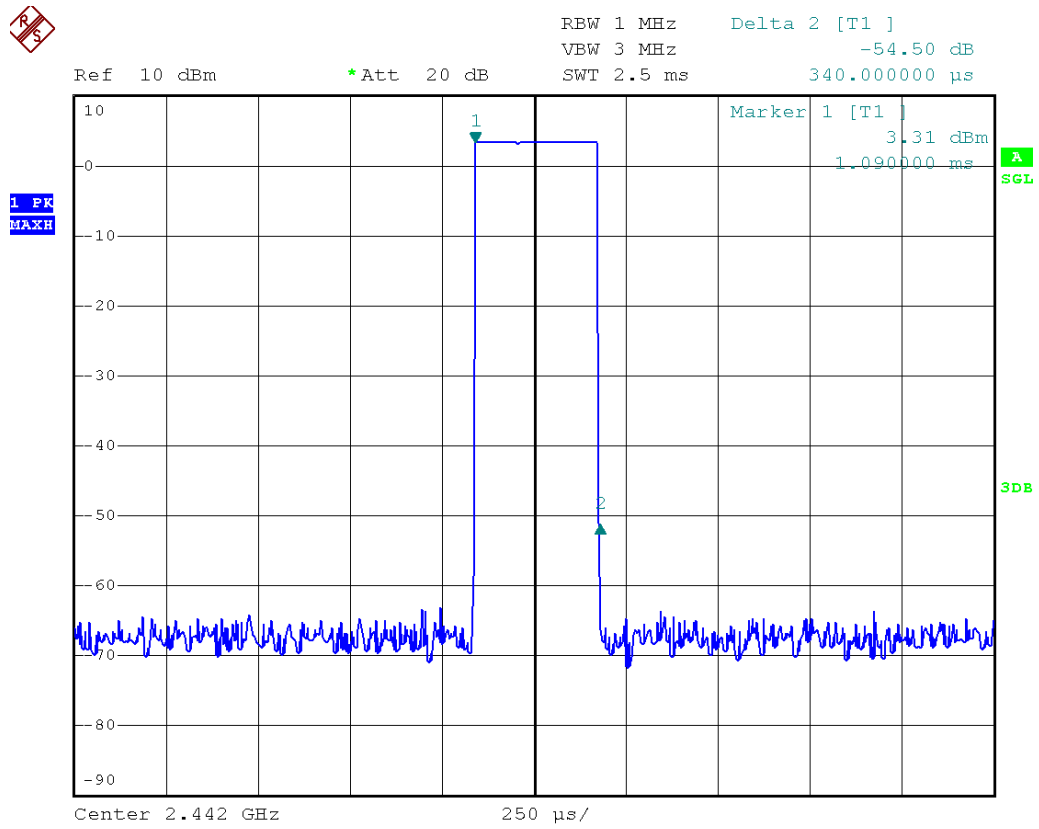

Figure 5: Number of transmission at 30.4 s

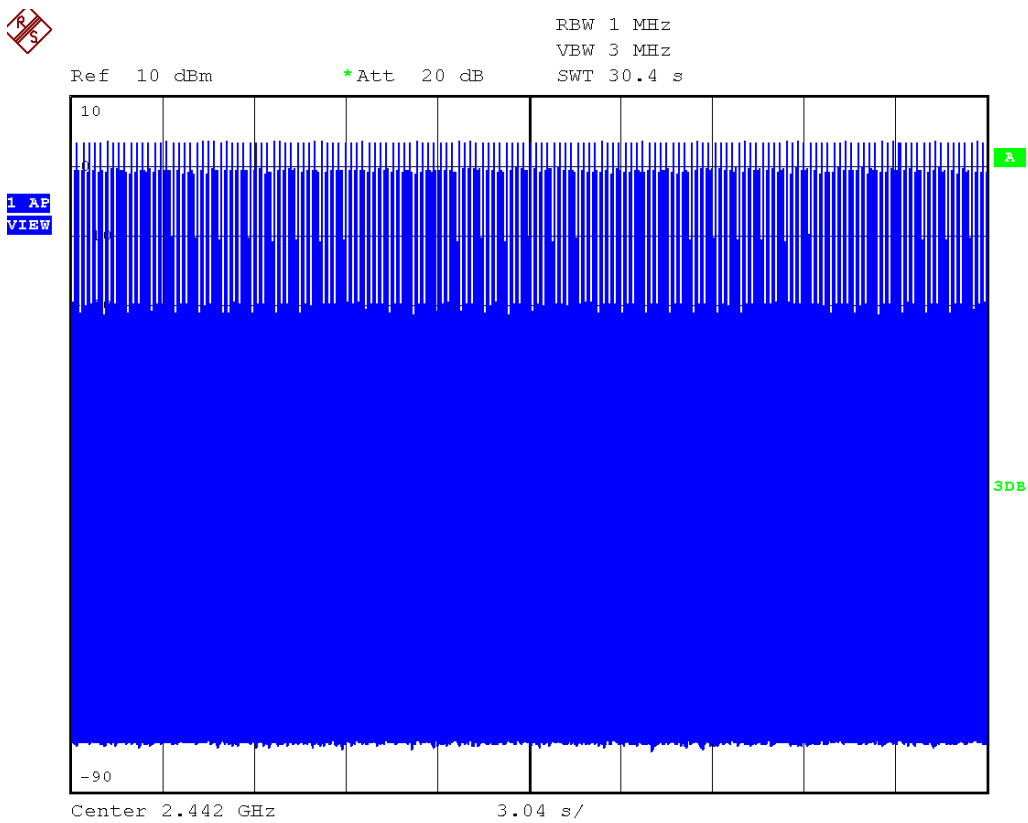
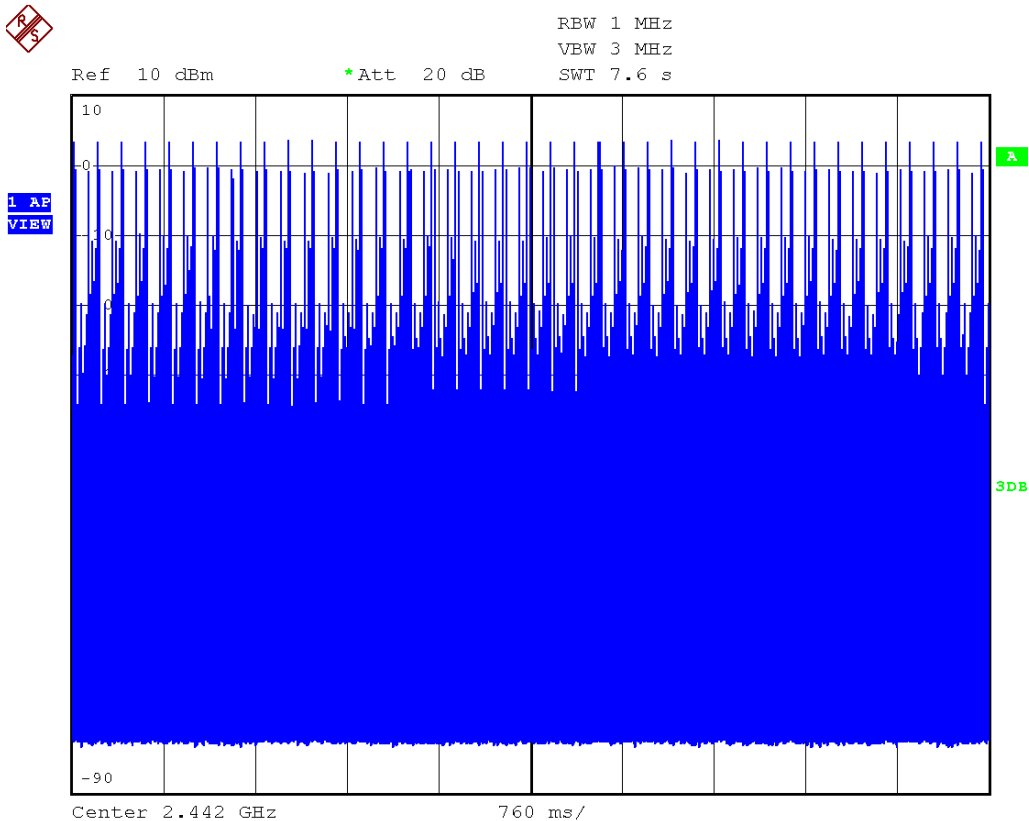

Figure 6: Number of Transmission at 7.6 s



6.4 Peak Output Power Measurement

Applicable Standard:

According to §15.247(b), 1) For frequency hopping systems operating in the 2400-2483.5 MHz band employing at least 75 hopping channels, and all frequency hopping systems in the 5725-5850MHz band: 1Watt. 2) For all other frequency hopping systems in the 2400 – 2483.5MHz band: 0.125 Watts. 3) For systems using digital modulation in the 902-928 MHz, 2400-2483.5 MHz, and 5725-5850 MHz bands: 1 Watt. As an alternative to a peak power measurement, compliance with the one Watt limit can be based on a measurement of the maximum conducted output power.

According to RSS-210 issue 8, §A8.4 (2), for frequency hopping systems operating in the 2400-2483.5 MHz band employing at least 75 hopping channels, the maximum conducted output power shall not exceed 1 W. For all other frequency hopping systems, the maximum peak conducted output power shall not exceed 0.125 W. (4) For systems employing digital modulation techniques operating in the bands 902-928 MHz, 2400-2483.5 MHz and 5725-5850 MHz, the maximum peak conducted output power shall not exceed 1 W.

Test Procedure:

1. Connect the EUT RF output port to spectrum analyzer via calibrated coaxial cable and suitable attenuator (if necessary).
2. Activates the EUT System and executes the software prepared for test, if necessary.
3. To find out the worst case, the transmitting data rate of EUT is varied with the different modes of operation. The final test condition is recorded in this report.
4. The spectrums are scanned and allow the trace to stabilize.
5. The peak output power was determined by using the marker-data function of spectrum analyzer or peak type power meter.

Spectrum analyzer set up conditions

Frequency span : 5 times 20dB bandwidth of the emission being measured

Resolution bandwidth : 3MHz

Video bandwidth : \cong RBW

Sweep : Auto

Detector function : Peak

Trace mode : Max hold

Test Result:

Temperature:	20 °C
Humidity:	57%
EUT Operation:	Data transmission without hopping
Test Date:	February 17, 2014

Frequency	Factor	Reading	Power	Limit	Margin
[MHz]	[dB]	[dBm]	[dBm]	[dBm]	[dB]
2403	1.0	4.41	5.41	30.00	24.59
2442	1.0	4.20	5.20	30.00	24.80
2478	1.0	3.93	4.93	30.00	25.07

Note: Test plots shown in figures 7 to 9 on pages 20 to 21.

Figure 7: Peak output power - Low channel

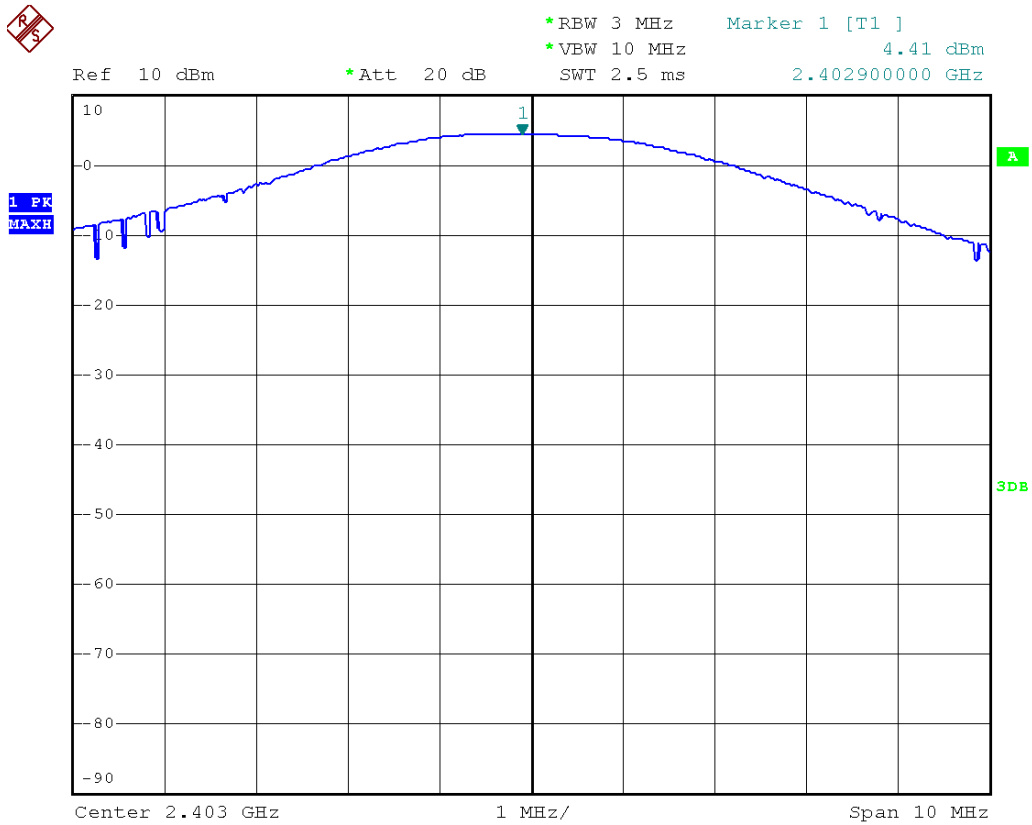

Figure 8: Peak output power - Middle channel

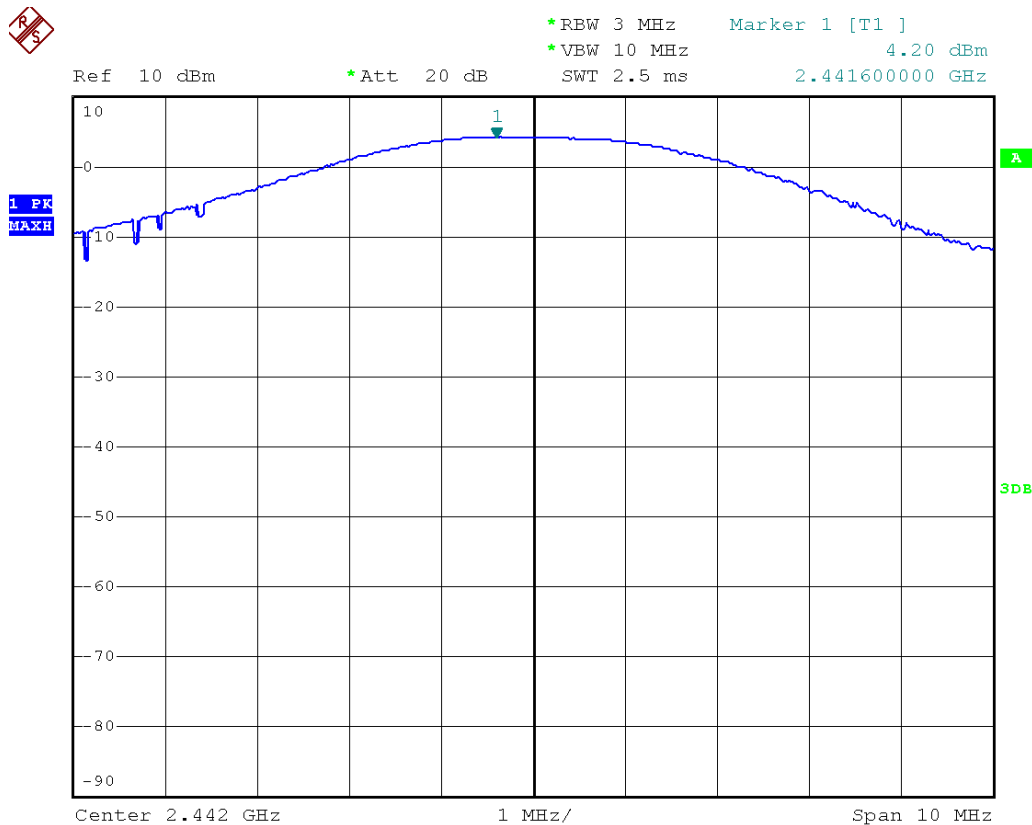
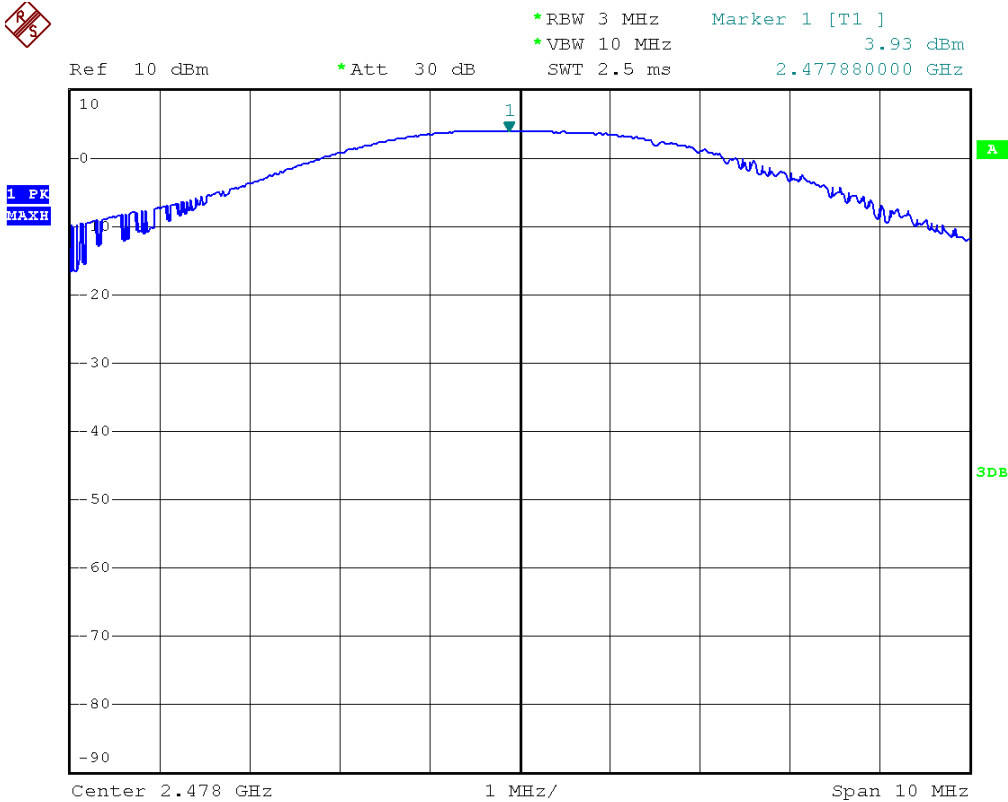

Figure 9: Peak output power - High channel



6.5 Band Edge of Conducted Emission and Spurious RF Conducted Emissions

Applicable Standard:

According to §15.247(d), in any 100 KHz bandwidth outside the frequency bands in which the spread spectrum intentional radiator is operating, the radio frequency power that is produced by the intentional radiator shall be at least 20dB below that in the 100KHz bandwidth within the band that contains the highest level of the desired power. In addition, radiated emissions which fall in the restricted bands, as defined in §15.205(a), must also comply with the radiated emission limits specified in 15.209(a).

According to RSS-210 issue 8, §A8.5, In any 100 kHz bandwidth outside the frequency band in which the spread spectrum or digitally modulated device is operating, the radio frequency power that is produced shall be at least 20 dB below that in the 100 kHz bandwidth within the band that contains the highest level of the desired power, based on either an RF conducted or a radiated measurement, provided the transmitter demonstrates compliance with the peak conducted power limits. If the transmitter complies with the conducted power limits based on the use of RMS averaging over a time interval, as permitted under section A8.4(4), the attenuation required shall be 30 dB instead of 20 dB. Attenuation below the general limits specified in Tables 2 and 3 is not required. In addition, radiated emissions which fall in the restricted bands of Table 1 must also comply with the radiated emission limits specified in Tables 2 and 3.

Test Procedure:

1. Connect the EUT RF output port to the spectrum analyzer via calibrated coaxial cable and suitable attenuator (if necessary).
2. Activate the EUT System and execute the software prepared for test, if necessary.
3. To find out the maximum emission condition, the transmitting data rate of EUT is set to maximum data rate.
4. The spectrum is scanned.
5. The emission at the band edge or the highest modulation product outside of band were measured by using the marker function of spectrum analyzer (*1).
6. The peak of the in-band emission were measured by using the marker to peak function of spectrum analyzer.
7. Above measurement were repeated at other side band edge.

Spectrum analyzer setup conditions:

Frequency span : Wide enough to capture the peak level of emission on the band edge

Resolution bandwidth : 100kHz

Video bandwidth : \geq RBW

Sweep : Auto

Detector function : Peak

Trace mode : Max hold

Test Results:

Temperature:	21 °C
Humidity:	55%
EUT Operation:	Data transmission with and without hopping
Test Date:	February 14, 2014

The unit does meet the requirements.

Note: Test plots shown in figures 10 to 16 on pages 24 to 28.

Figure 10: Band edge - Low frequency side without hopping

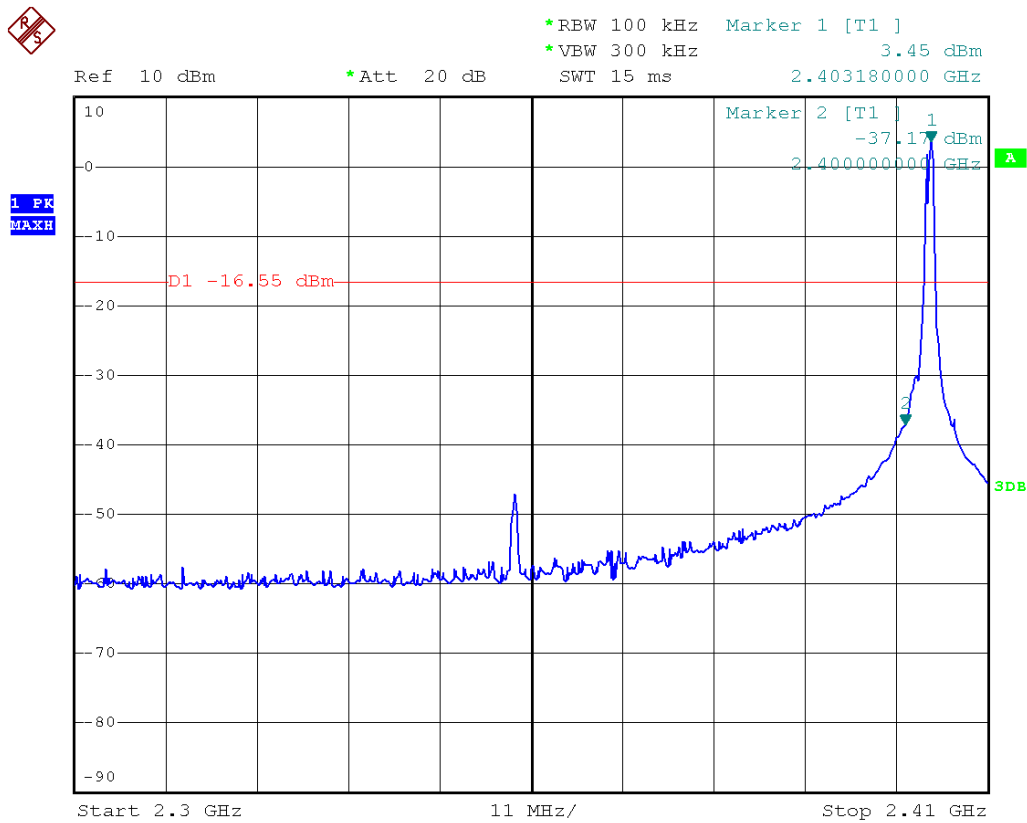

Figure 11: Band edge – High frequency side without hopping

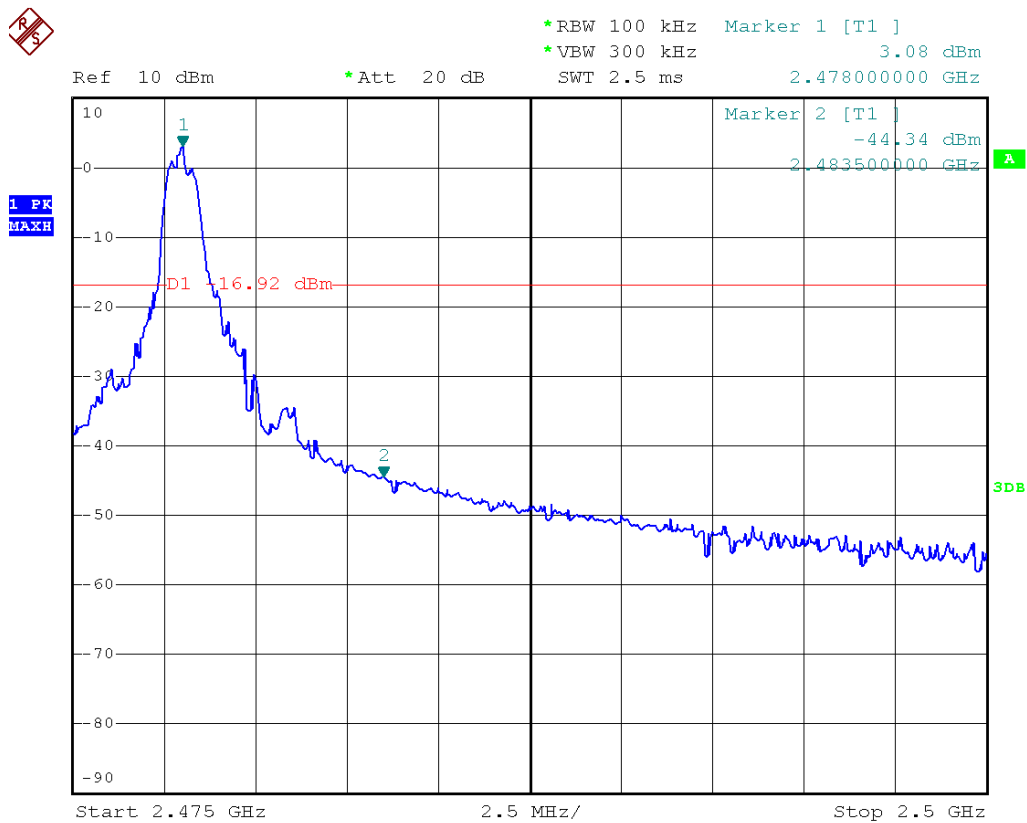

Figure 12: Band edge – Low frequency side with hopping

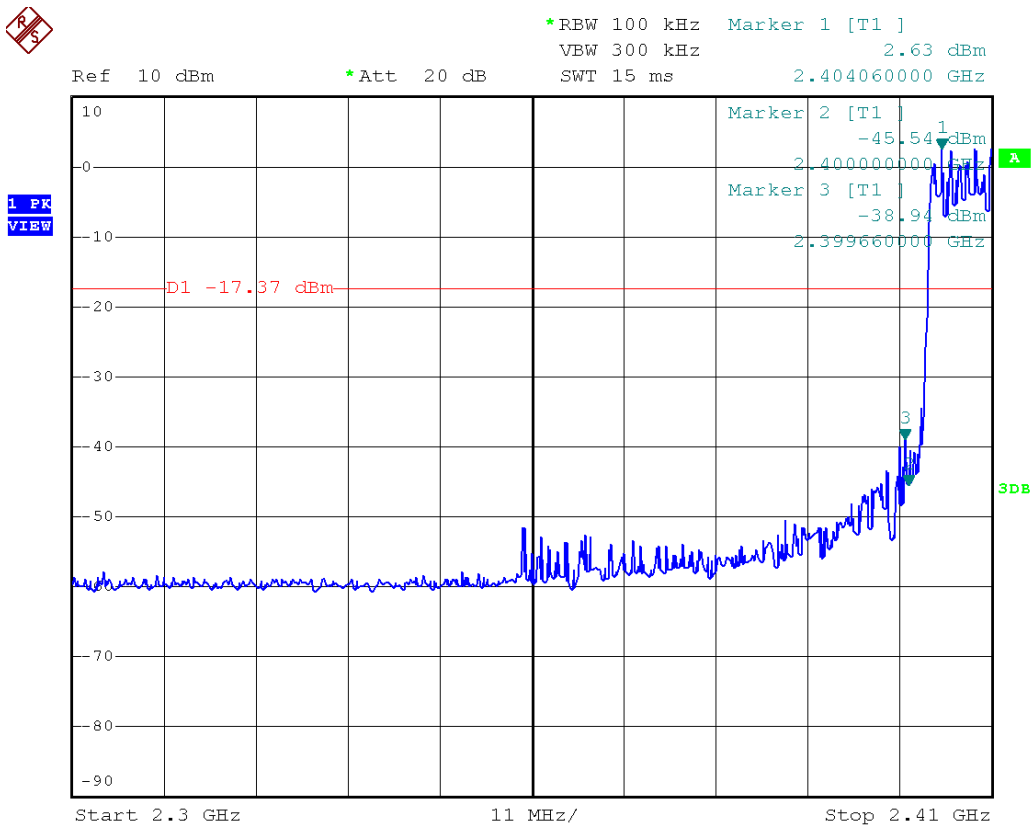

Figure 13: Band edge – High frequency side with hopping

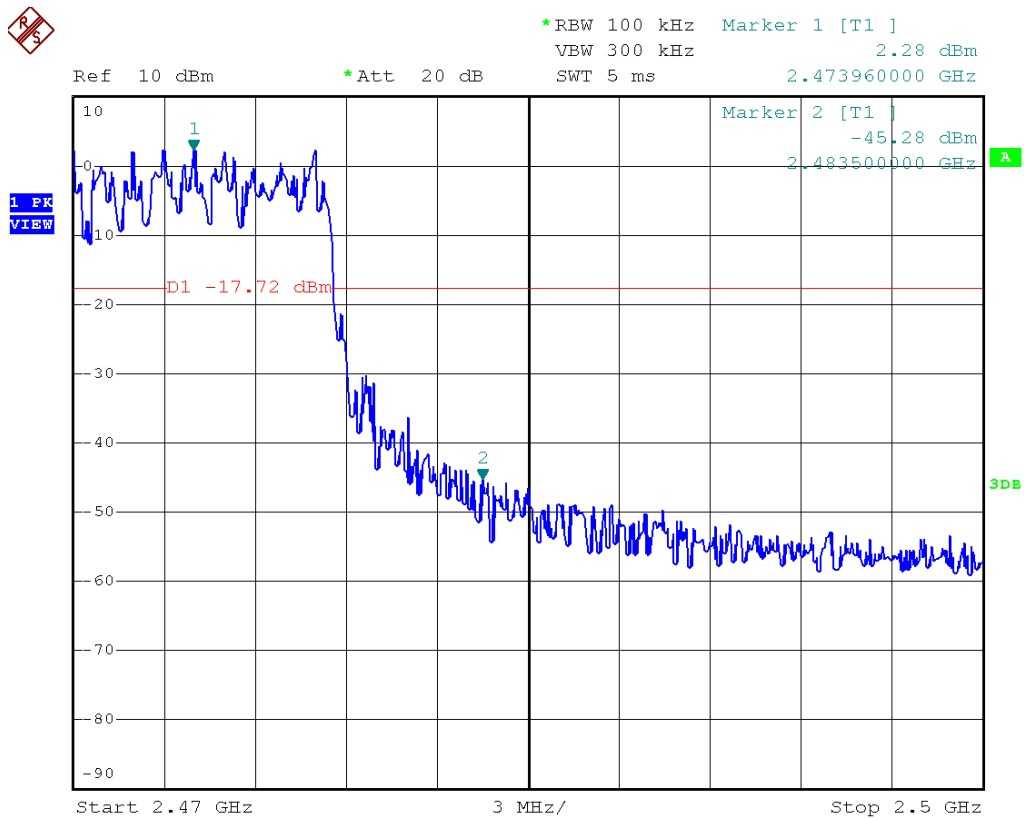

Figure 14 Conducted spurious emissions - Low channel

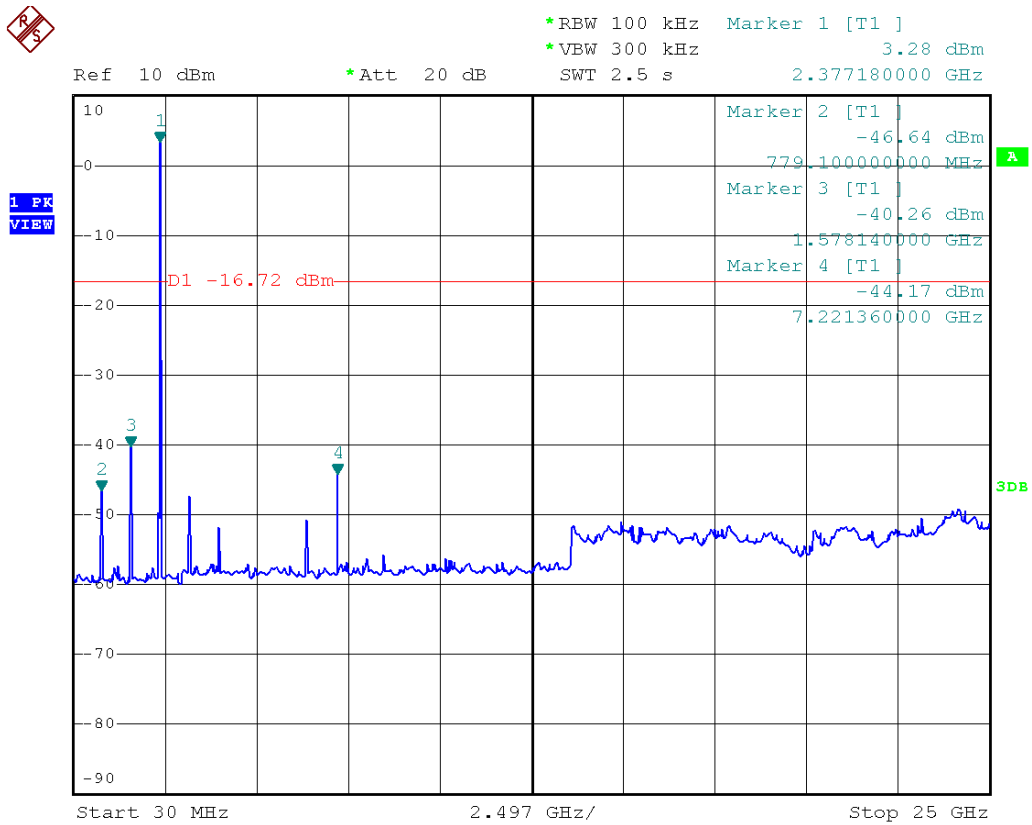

Figure 15 Conducted spurious emissions - Middle channel

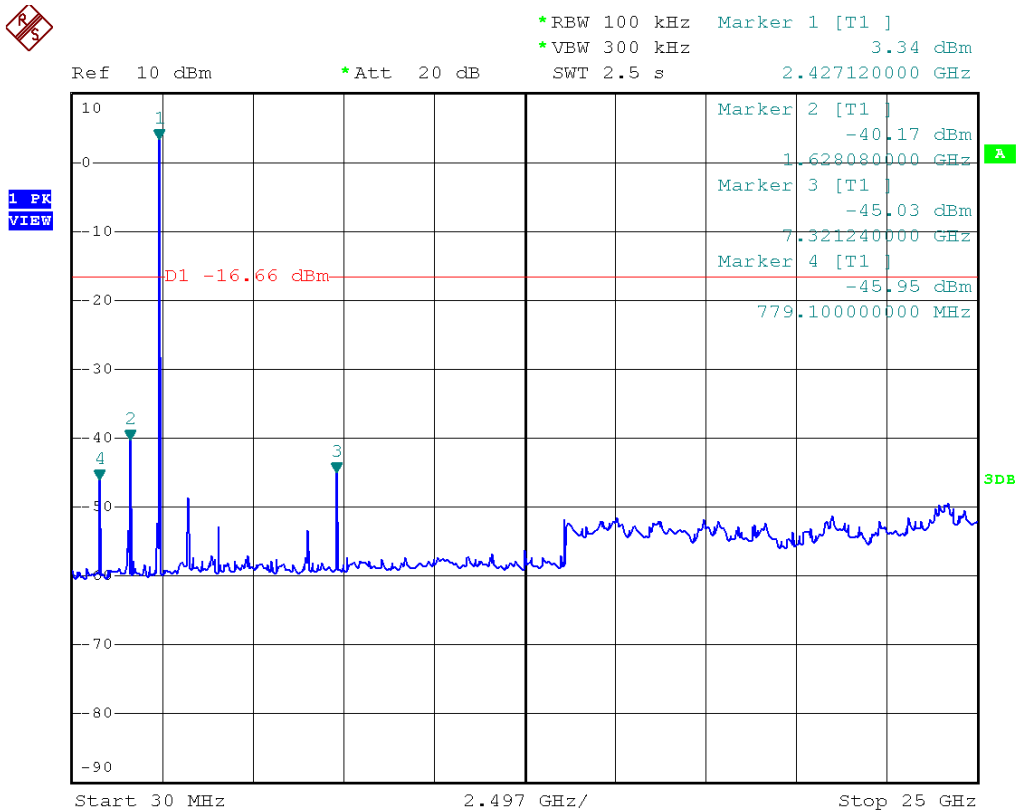
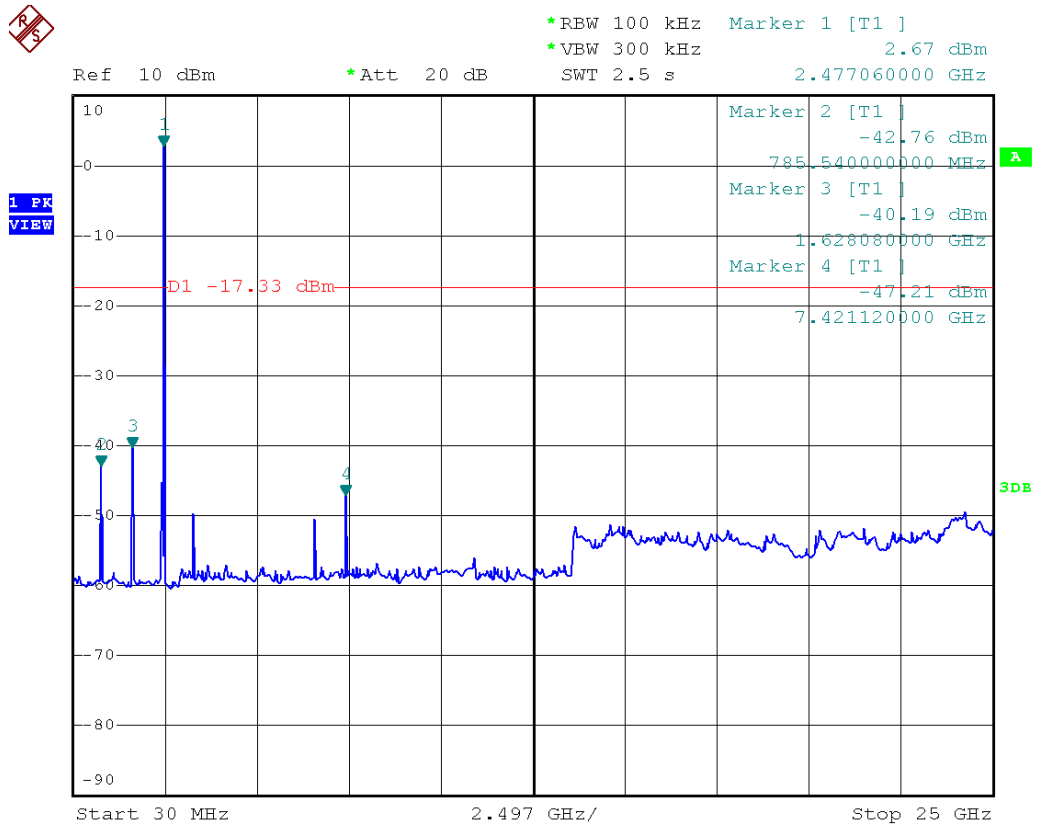

Figure 16 Conducted spurious emissions - High channel



6.6 Spurious Radiated Emission Measurement

Applicable Standard:

According to §15.247(c), all other emissions outside these bands shall not exceed the general radiated emission limits specified in §15.209(a). And according to §15.33(a)(1), for an intentional radiator operates below 10GHz, the frequency range of measurements: to the tenth harmonic of the highest fundamental frequency or to 40GHz, whichever is lower. According to §15.31(o), the amplitude of spurious emissions from intentional radiators and emissions from unintentional radiators which are attenuated more than 20 dB below the permissible value need not be reported unless specifically required elsewhere in this part.

According to RSS-210 issue 8, §A8.5, in any 100 kHz bandwidth outside the frequency band in which the spread spectrum or digitally modulated device is operating, the radio frequency power that is produced shall be at least 20 dB below that in the 100 kHz bandwidth within the band that contains the highest level of the desired power, based on either an RF conducted or a radiated measurement, provided the transmitter demonstrates compliance with the peak conducted power limits. If the transmitter complies with the conducted power limits based on the use of RMS averaging over a time interval, as permitted under section A8.4(4), the attenuation required shall be 30 dB instead of 20 dB. Attenuation below the general limits specified in Tables 2 and 3 is not required. In addition, radiated emissions which fall in the restricted bands of Table 1 must also comply with the radiated emission limits specified in Tables 2 and 3.

Test Procedure:

1. The EUT was placed on a turn table which is 0.8m above ground plane.
2. The turn table shall rotate 360 degrees to determine the position of maximum emission level.
3. EUT is set 3m away from the receiving antenna which varied from 1m to 4m to find out the highest emissions.
4. Maximum procedure was performed on the six highest emissions to ensure EUT compliance.
5. And also, each emission was to be maximized by changing the polarization of receiving antenna both horizontal and vertical.
6. Repeat above procedures until all frequency measured were completed.

The field strength is calculated by adding the Antenna Factor and Cable Factor and subtracting the Amplifier Gain and Duty Cycle Correction Factor(if any) from the measured reading. The basic equation with a sample calculation is as follows:

$$FS = RA + AF + CL - AG$$

Where FS = Field Strength	CL = Cable Attenuation Factor (Cable Loss)
RA = Reading Amplitude	AG = Amplifier Gain
AF = Antenna Factor	

Test Configuration between 9K to 1 GHz:

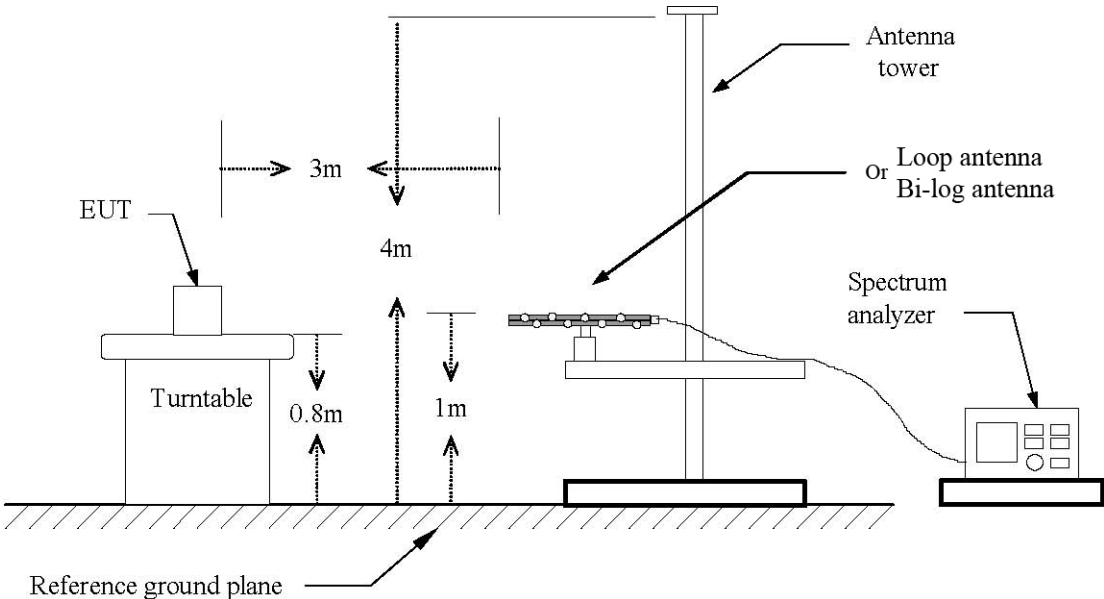

Test Configuration above 1 GHz:

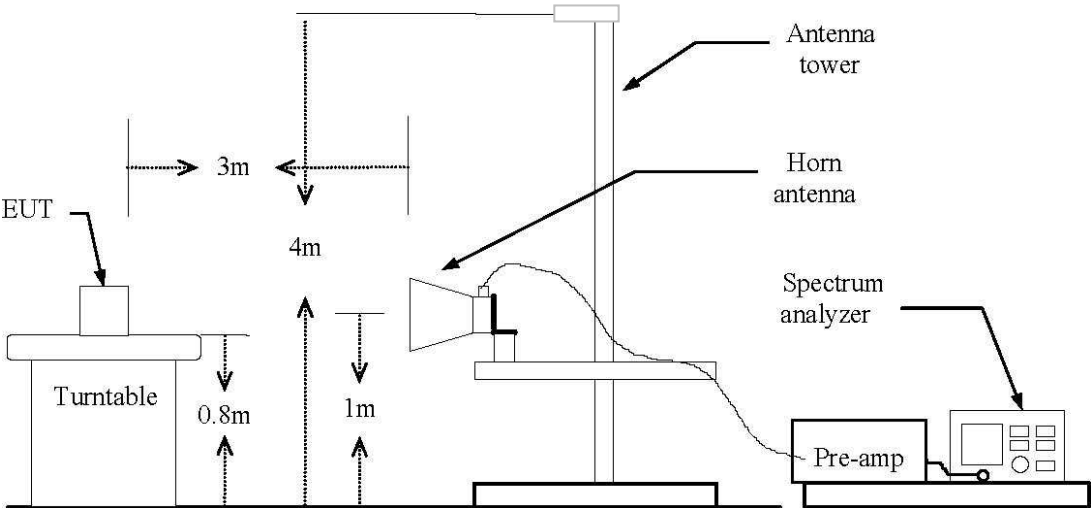

Test Results:

Temperature:	24°C
Humidity:	52%
EUT Operation:	Data transmission without hopping
Test Date:	February 17, 2014

Spurious Emission in the Frequency Rang between 9KHz to 1GHz:

Fc=2403MHz Transmitting operation

Freq. (MHz)	Ant.Pol. (H/V)	Detector Mode (PK/QP)	Reading (dBuV)	Ant./CL/ Amp.CF (dB)	Actual FS (dBuV/m)	Limit 3m (dBuV/m)	Margin (dB)
30.66	H	QP	13.1	16.7	29.8	40.0	-10.2
824.64	H	QP	20.7	22.5	43.2	46.0	-2.8
30.18	V	QP	7.1	16.7	23.8	40.0	-16.2
824.60	V	QP	10.8	22.5	33.3	46.0	-12.7

Fc=2442MHz Transmitting operation

Freq. (MHz)	Ant.Pol. (H/V)	Detector Mode (PK/QP)	Reading (dBuV)	Ant./CL/ Amp.CF (dB)	Actual FS (dBuV/m)	Limit 3m (dBuV/m)	Margin (dB)
30.64	H	QP	12.5	16.7	29.2	40.0	-10.8
824.66	H	QP	19.8	22.5	42.3	46.0	-3.7
30.40	V	QP	6.9	16.7	23.6	40.0	-16.4
823.80	V	QP	12.0	22.5	34.5	46.0	-11.5

Fc=2478MHz Transmitting operation

Freq. (MHz)	Ant.Pol. (H/V)	Detector Mode (PK/QP)	Reading (dBuV)	Ant./CL/ Amp.CF (dB)	Actual FS (dBuV/m)	Limit 3m (dBuV/m)	Margin (dB)
30.50	H	QP	11.5	16.7	28.2	40.0	-11.8
824.60	H	QP	19.3	22.5	41.8	46.0	-4.2
30.46	V	QP	6.1	16.7	22.8	40.0	-17.2
824.20	V	QP	11.0	22.5	33.5	46.0	-12.5

Note: For spurious emission measurement, the compliance tests were performed both of horizontally placed and vertically placed in EUT (X position, Y position, Z position). As a result, the data of operation mode that produce the maximum emission were reported. The other emissions are more than 20dB below the limit.

Spurious Emission In the Frequency Rang above 1GHz:

Fc=2403MHz Transmitting operation - Horizontal

Freq. (MHz)	Peak Reading (dBuV)	AV Reading (dBuV)	Ant./CL/ Amp.CF (dB)	Actual FS		Peak Limit (dBuV/m)	AV Limit (dBuV/m)	Margin
				Peak (dBuV/m)	AV (dBuV/m)			
4808.00	50.08	36.03	0.92	51.00	36.95	74.00	54.00	-17.05
7188.00	58.40	38.24	4.22	62.62	42.46	74.00	54.00	-11.38
-								

Fc=2403MHz Transmitting operation - Vertical

Freq. (MHz)	Peak Reading (dBuV)	AV Reading (dBuV)	Ant./CL/ Amp.CF (dB)	Actual FS		Peak Limit (dBuV/m)	AV Limit (dBuV/m)	Margin
				Peak (dBuV/m)	AV (dBuV/m)			
4808.00	52.70	38.35	0.92	53.62	39.27	74.00	54.00	-14.73
7188.00	61.82	38.61	4.22	66.04	42.83	74.00	54.00	-7.96
-								

Note: Data of measurement within this frequency range shown “-” in the table above means the reading of emissions are attenuated more than 20dB below the permissible limits or the field strength is too small to be measured.

Fc=2442MHz Transmitting operation - Horizontal

Freq. (MHz)	Peak Reading (dBuV)	AV Reading (dBuV)	Ant./CL/ Amp.CF (dB)	Actual FS		Peak Limit (dBuV/m)	AV Limit (dBuV/m)	Margin
				Peak (dBuV/m)	AV (dBuV/m)			
4876.00	51.68	38.24	0.92	52.60	39.16	74.00	54.00	-14.84
7324.00	58.26	38.52	4.22	62.48	42.74	74.00	54.00	-11.26
-								

Fc=2442MHz Transmitting operation - Vertical

Freq. (MHz)	Peak Reading (dBuV)	AV Reading (dBuV)	Ant./CL/ Amp.CF (dB)	Actual FS		Peak Limit (dBuV/m)	AV Limit (dBuV/m)	Margin
				Peak (dBuV/m)	AV (dBuV/m)			
4876.00	51.86	38.64	0.92	52.78	39.56	74.00	54.00	-14.44
7324.00	61.93	39.54	4.22	66.15	43.76	74.00	54.00	-7.85
-								

Note: Data of measurement within this frequency range shown “-” in the table above means the reading of emissions are attenuated more than 20dB below the permissible limits or the field strength is too small to be measured.

Fc=2478MHz Transmitting operation - Horizontal

Freq. (MHz)	Peak Reading (dBuV)	AV Reading (dBuV)	Ant./CL/ Amp.CF (dB)	Actual FS		Peak Limit (dBuV/m)	AV Limit (dBuV/m)	Margin
				Peak (dBuV/m)	AV (dBuV/m)			
4944.00	52.20	38.13	0.92	53.12	39.05	74.00	54.00	-14.95
7426.00	59.09	39.64	4.22	63.31	43.86	74.00	54.00	-10.14
-								

Fc=2478MHz Transmitting operation - Vertical

Freq. (MHz)	Peak Reading (dBuV)	AV Reading (dBuV)	Ant./CL/ Amp.CF (dB)	Actual FS		Peak Limit (dBuV/m)	AV Limit (dBuV/m)	Margin
				Peak (dBuV/m)	AV (dBuV/m)			
4944.00	51.20	39.10	0.92	52.12	40.02	74.00	54.00	-13.98
7426.00	61.06	38.02	4.22	65.28	42.24	74.00	54.00	-8.72
-								

Note: Data of measurement within this frequency range shown “-” in the table above means the reading of emissions are attenuated more than 20dB below the permissible limits or the field strength is too small to be measured.

6.7 Conducted Emission Measurement

Applicable Standard:

According to §15.207(a), except as shown in paragraphs (b) and (c) of this section, for an intentional radiator that is designed to be connected to the public utility (AC) power line, the radio frequency voltage that is conducted back onto the AC power line on any frequency or frequencies within the band 150 kHz to 30 MHz shall not exceed the limits in the following table, as measured using a 50 μ H/50 ohms line impedance stabilization network (LISN). Compliance with the provisions of this paragraph shall be based on the measurement of the radio frequency voltage between each power line and ground at the power terminal. The lower limit applies at the boundary between the frequency ranges.

Frequency of Emission (MHz)	Conducted Limit (dB μ V)	
	Quasi-peak	Average
0.15 ~ 0.5	66 to 56*	56 to 46*
0.5 ~ 5	56	46
5 ~ 30	60	50

Note: *Decreases with the logarithm of the frequency.

Measurements to demonstrate compliance with the conducted limits are not required for devices which only employ battery power for operation and which do not operate from the AC power lines or contain provisions for operation while connected to the AC power lines. Devices that include, or make provisions for, the use of battery chargers which permit operating while charging, AC adapters or battery eliminators or that connect to the AC power lines indirectly, obtaining their power through another device which is connected to the AC power lines, shall be tested to demonstrate compliance with the conducted limits.

According to RSS-GEN Section 7.2.2, the purpose of this test is to measure unwanted radio frequency currents induced in any AC conductor external to the equipment which could conduct interference to other equipment via the AC electrical network. Except when the requirements applicable to a given device state otherwise, for any licence-exempt radio communication device equipped to operate from the public utility AC power supply, either directly or indirectly, the radio frequency voltage that is conducted back onto the AC power lines in the frequency range of 0.15 MHz to 30 MHz shall not exceed the limits shown in Table 2. The tighter limit applies at the frequency range boundaries.

The conducted emissions shall be measured with a 50 ohm/50 microhenry line impedance stabilization network.

Test Procedure:

1. The EUT was placed on a table which is at least 0.8 m high. Place the EUT so that it is 0.4 m from the wall of the shielding room, or place the EUT on a table which is 0.4 m high so that the bottom of the EUT is 0.4 m above the ground plane.
2. All the other conductive surface of the EUT shall be at least 0.8 m from the reference ground plane.
3. If the mains lead of the EUT is longer than necessary to be connected to the LISN the length of this lead in excess of 0.8 m shall be folded back and forth parallel to the lead so as to form a horizontal bundle with a length between 0.3 m and 0.4 m.
4. Maximum procedure was performed on the six highest emissions to ensure EUT compliance.

Test Configuration:

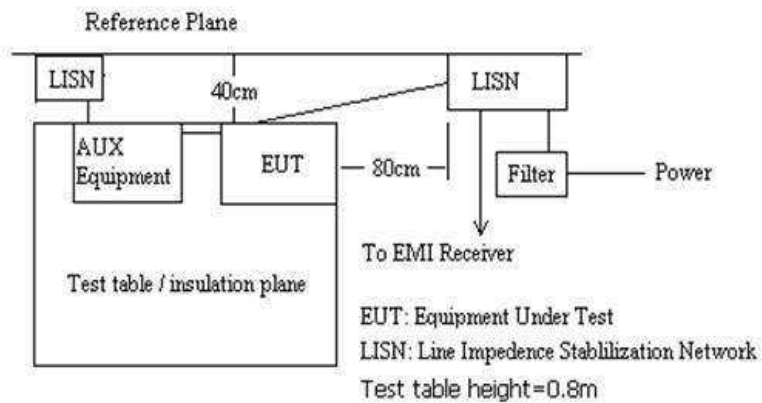

Test Result:

This test is not applicable to the EUT.

6.8 Band Edge and Restricted Band of Radiated Emission Measurement

Applicable Standard:

According to §15.247(d), radiated emissions which fall in the restricted bands, as defined in §15.205(a), must also comply with the radiated emission limits specified in 15.209(a).

According to RSS-210 issue 8, §A8.5, radiated emissions which fall in the restricted bands of Table 1 must also comply with the radiated emission limits specified in Tables 2 and 3.

According to DA 00-705, in making radiated band-edge measurements, the following technique for determining band-edge compliance.

Step 1) Perform an in-band field strength measurement of the fundamental emission using the RBW and detector function required by C63.4 and our Rules for the frequency being measured. For transmitters operating above 1 GHz, use a 1 MHz RBW, a 1 MHz VBW, and a peak detector (as required by Section 15.35). Repeat the measurement with an average detector (i.e., 1 MHz RBW with 10 Hz VBW).

Step 2) Choose a spectrum analyzer span that encompasses both the peak of the fundamental emission and the band-edge emission under investigation. Set the analyzer RBW to 1% of the total span (but never less than 30 kHz) with a video bandwidth equal to or greater than the RBW. Record the peak levels of the fundamental emission and the relevant band-edge emission (i.e., run several sweeps in peak hold mode). Observe the stored trace and measure the amplitude delta between the peak of the fundamental and the peak of the band-edge emission. This is not a field strength measurement, it is only a relative measurement to determine the amount by which the emission drops at the band-edge relative to the highest fundamental emission level.

Step 3) Subtract the delta measured in step (2) from the field strengths measured in step (1). The resultant field strengths (CISPR QP, average, or peak, as appropriate) are then used to determine band-edge compliance as required by Section 15.205.

Step 4) The above "delta" measurement technique may be used for measuring emissions that are up to two "standard" bandwidths away from the band-edge, where a "standard" bandwidth is the bandwidth specified by C63.4 for the frequency being measured.

Test Procedure:

1. The EUT was placed on a turn table which is 0.8m above ground plane.
2. The turn table shall rotate 360 degrees to determine the position of maximum emission level.
3. EUT is set 3m away from the receiving antenna which varied from 1m to 4m to find out the highest emissions.
4. Maximum procedure was performed on the highest emissions in restricted band to ensure EUT compliance.

The field strength is calculated by adding the Antenna Factor and Cable Factor and subtracting the Amplifier Gain and Duty Cycle Correction Factor(if any) from the measured reading. The basic equation with a sample calculation is as follows:

$$FS = RA + AF + CL - AG$$

Where FS = Field Strength	CL = Cable Attenuation Factor (Cable Loss)
RA = Reading Amplitude	AG = Amplifier Gain
AF = Antenna Factor	

Test Results:

Temperature:	21°C
Humidity:	52%
EUT Operation:	Data transmission without hopping
Test Date:	February 18, 2014

The unit does meet the requirements.
Test plots shown in figures 17 to 24 on pages 39 to 42.

Figure 17 Band edge of radiated emission – Low frequency side with hopping
Peak measurement in horizontal polarization

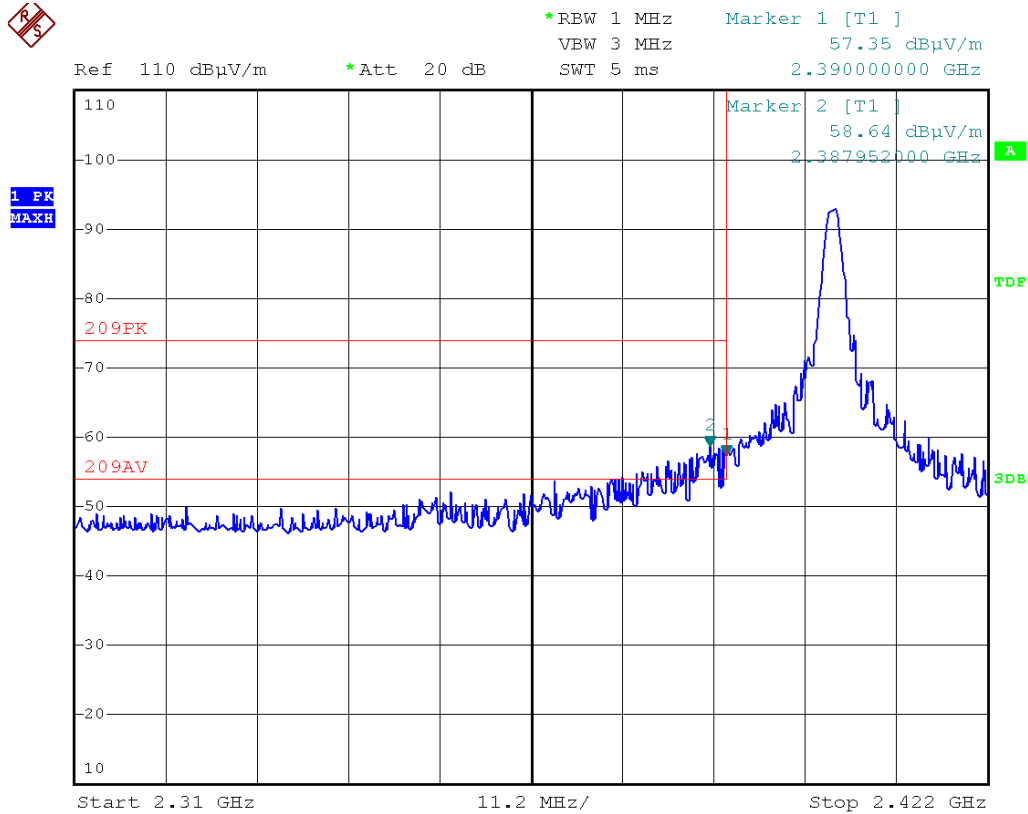

Figure 18 Band edge of radiated emission – Low frequency side without hopping
Average measurement in horizontal polarization

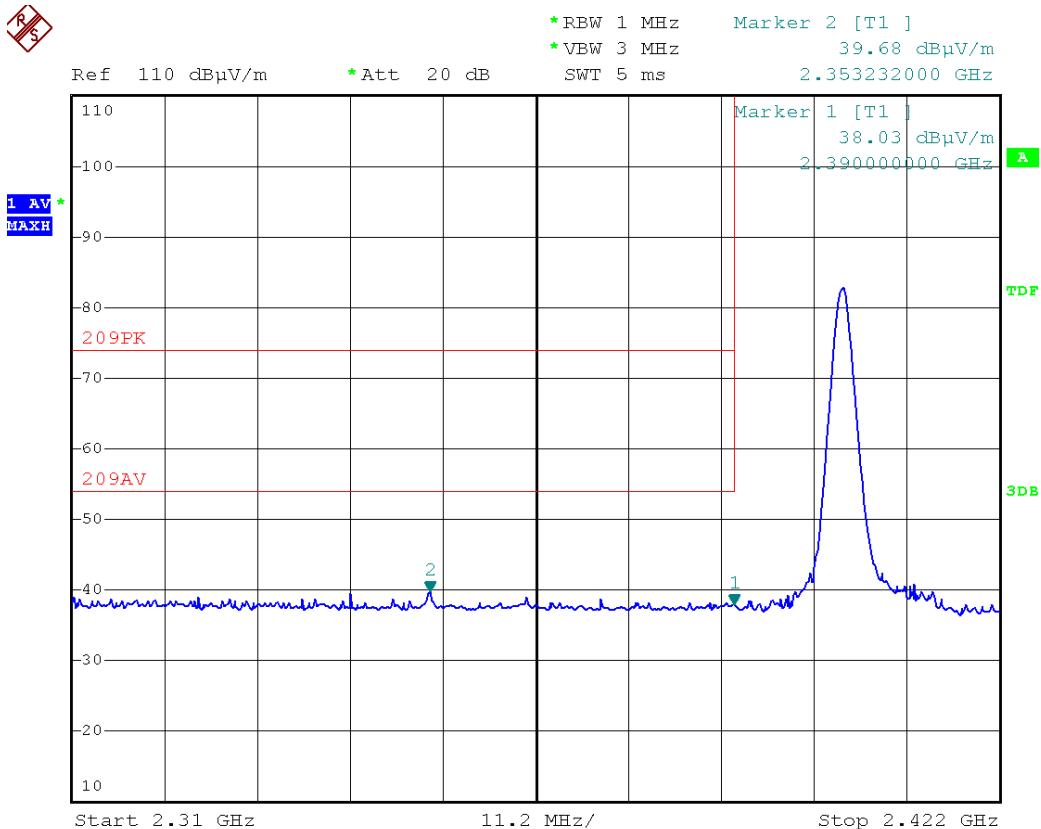

Figure 19 Band edge of radiated emission – Low frequency side with hopping
Peak measurement in vertical polarization

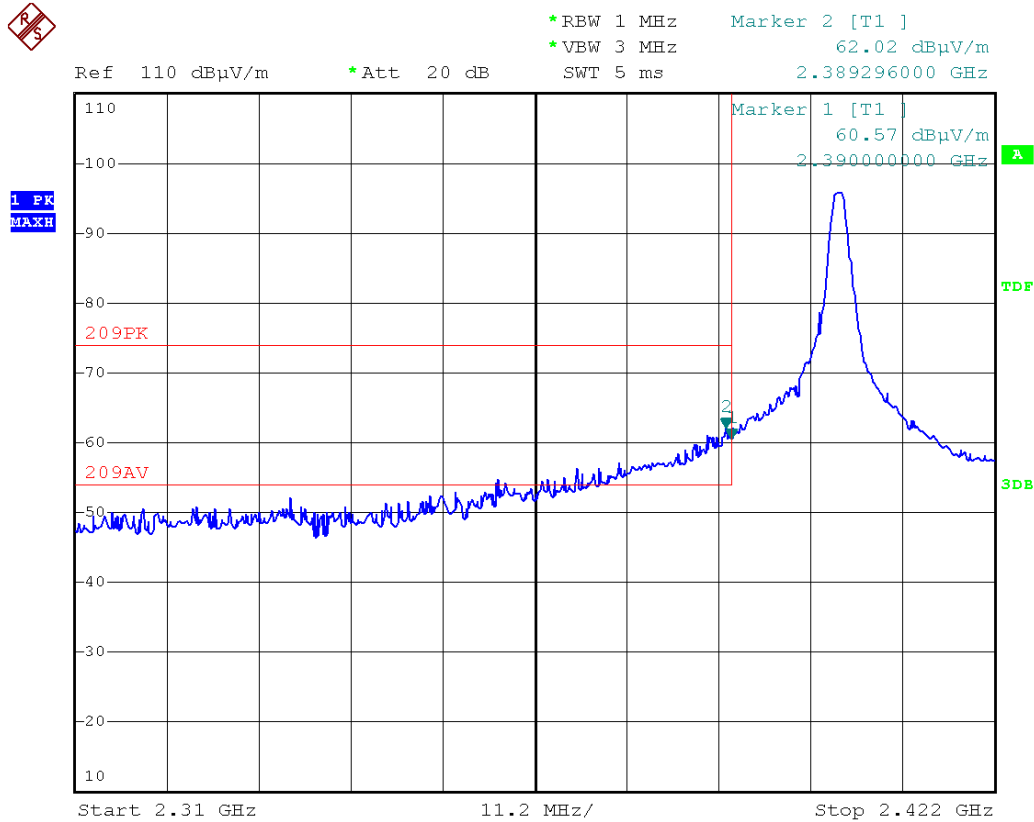

Figure 20 Band edge of radiated emission – Low frequency side without hopping
Average measurement in vertical polarization

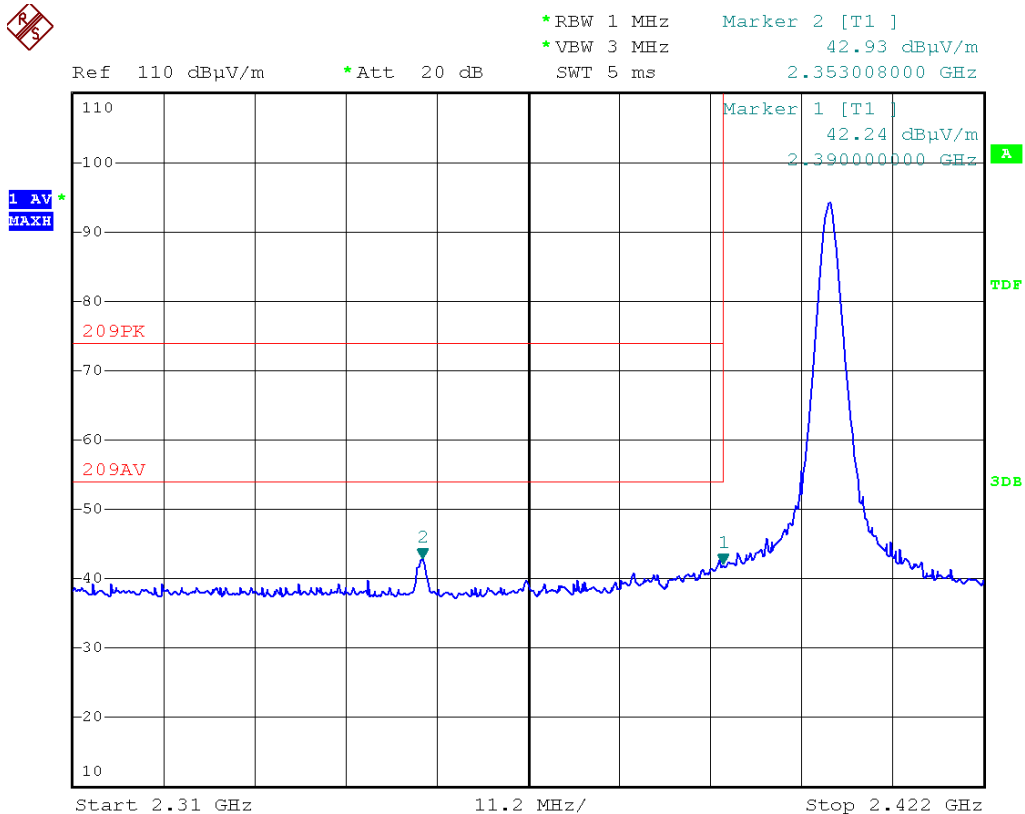

Figure 21 Band edge of radiated emission – High frequency side with hopping
Peak measurement in horizontal polarization

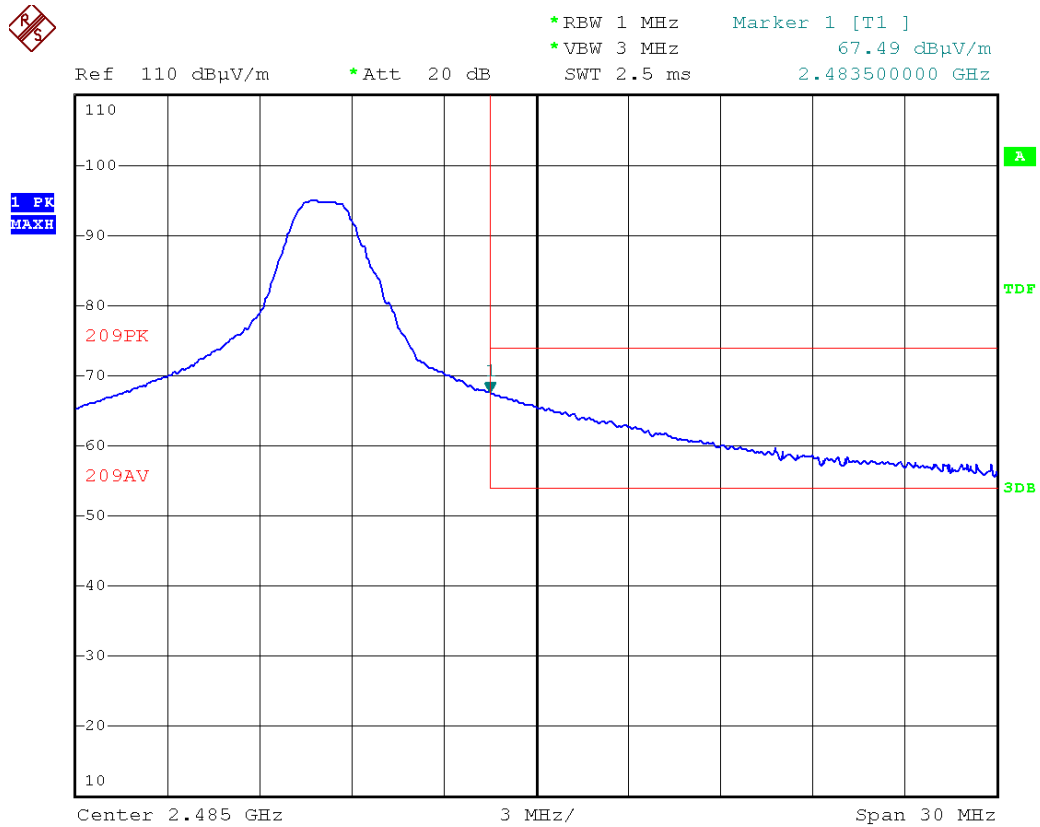

Figure 22 Band edge of radiated emission – High frequency side with hopping
Average measurement in horizontal polarization

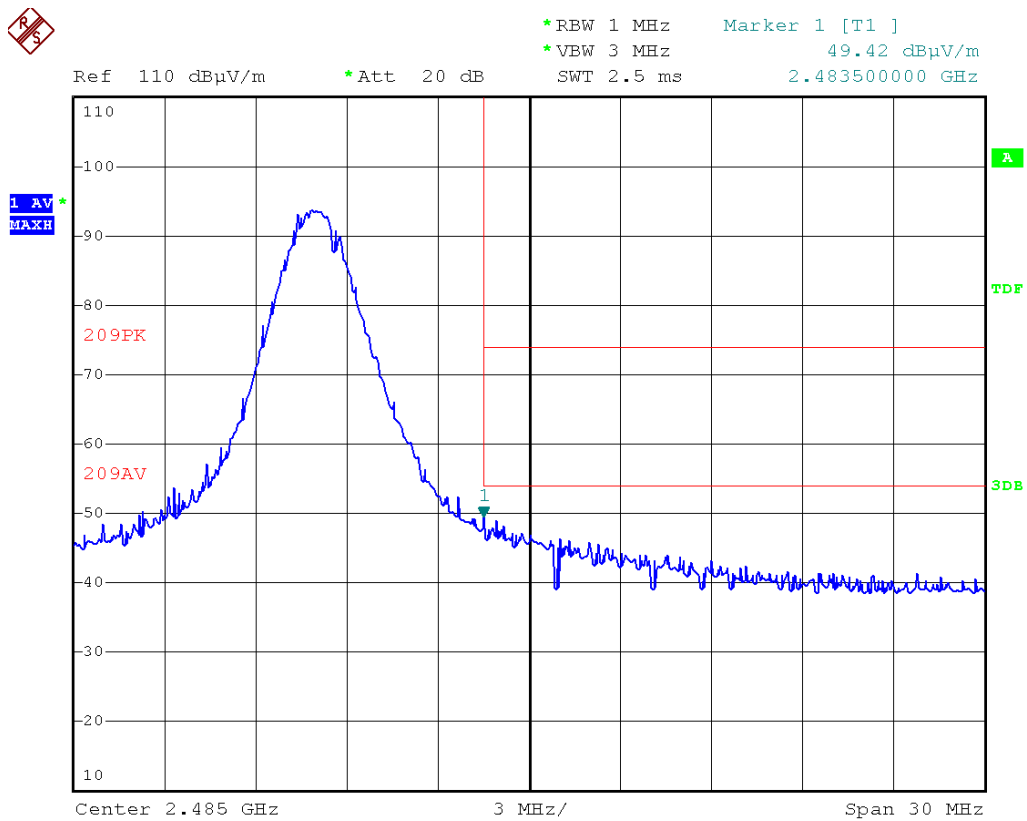

Figure 23 Band edge of radiated emission – High frequency side with hopping
Peak measurement in vertical polarization

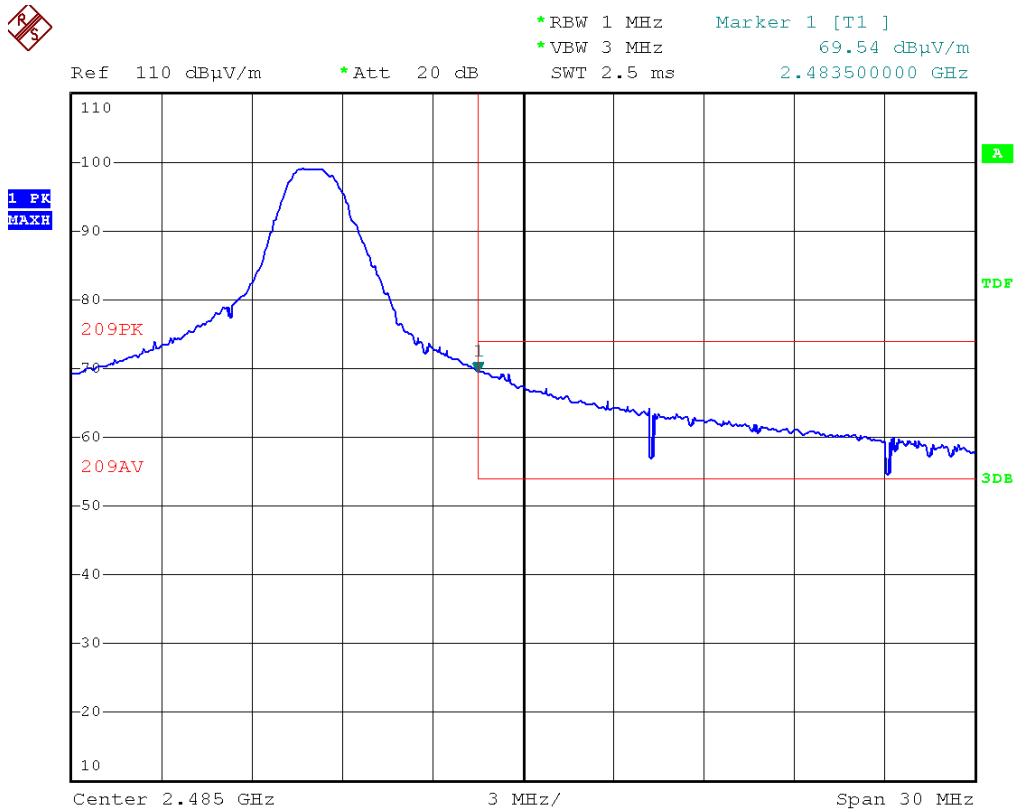
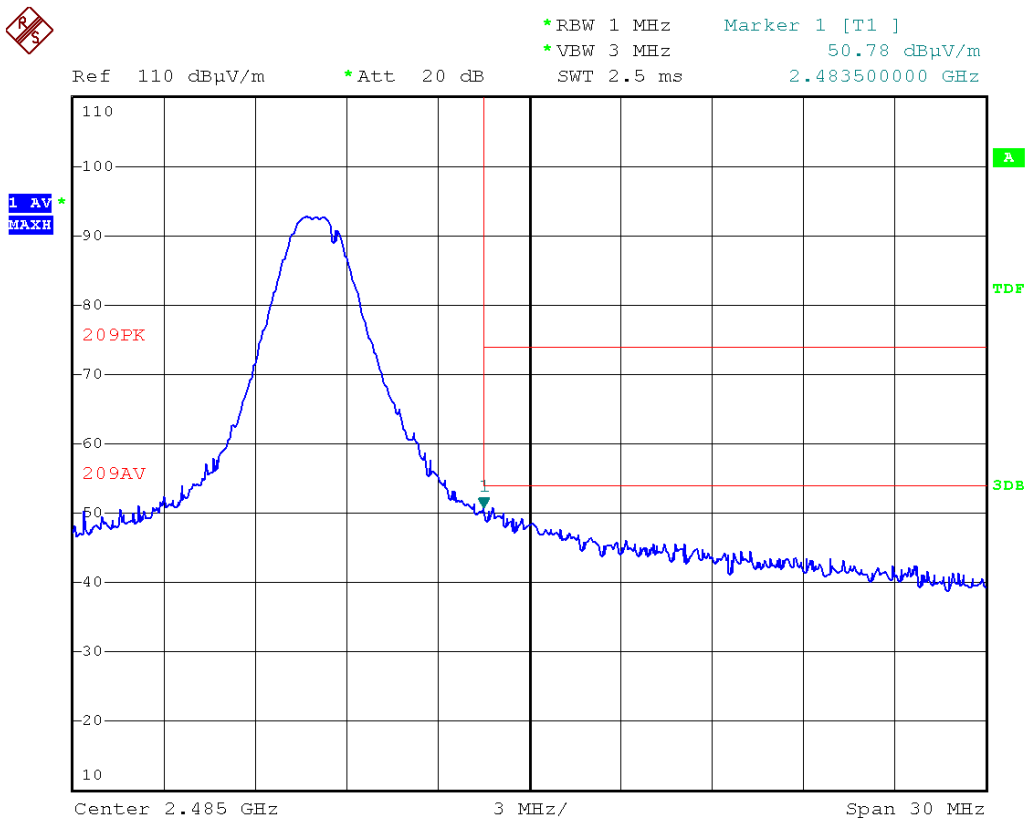

Figure 24 Band edge of radiated emission – High frequency side with hopping
Average measurement in vertical polarization



6.9 99% Bandwidth Measurement

Standard Applicable:

RSS-Gen §4.4.1, the transmitter shall be operated at its maximum carrier power measured under normal test conditions. The span of the analyzer shall be set to capture all products of the modulation process, including the emission skirts. The resolution bandwidth shall be set to as close to 1% of the selected span as is possible without being below 1%. The video bandwidth shall be set to 3 times the resolution bandwidth. Video averaging is not permitted. Where practical, a sampling detector shall be used since a peak or, peak hold, may produce a wider bandwidth than actual.

The trace data points are recovered and are directly summed in linear terms. The recovered amplitude data points, beginning at the lowest frequency, are placed in a running sum until 0.5% of the total is reached and that frequency recorded. The process is repeated for the highest frequency data points. This frequency is recorded. The span between the two recorded frequencies is the occupied bandwidth.

Spectrum analyzer set up conditions:

- Span = 2MHz
- Resolution bandwidth = 30KHz
- Video bandwidth = 100KHz
- Sweep = auto
- Detector function = peak
- Trace = max hold

Test Results:

Temperature:	20°C
Humidity:	54%
EUT Operation:	Data Transmission (without hopping)
Test Date:	February 16, 2014

Frequency (MHz)	99% Bandwidth (MHz)
2403	1.164
2442	1.216
2478	1.304

Note: Test plots shown in figures 25 to 27 on pages 44 to 45.

Figure 25- 99% Bandwidth measurement (fc=2403MHz)

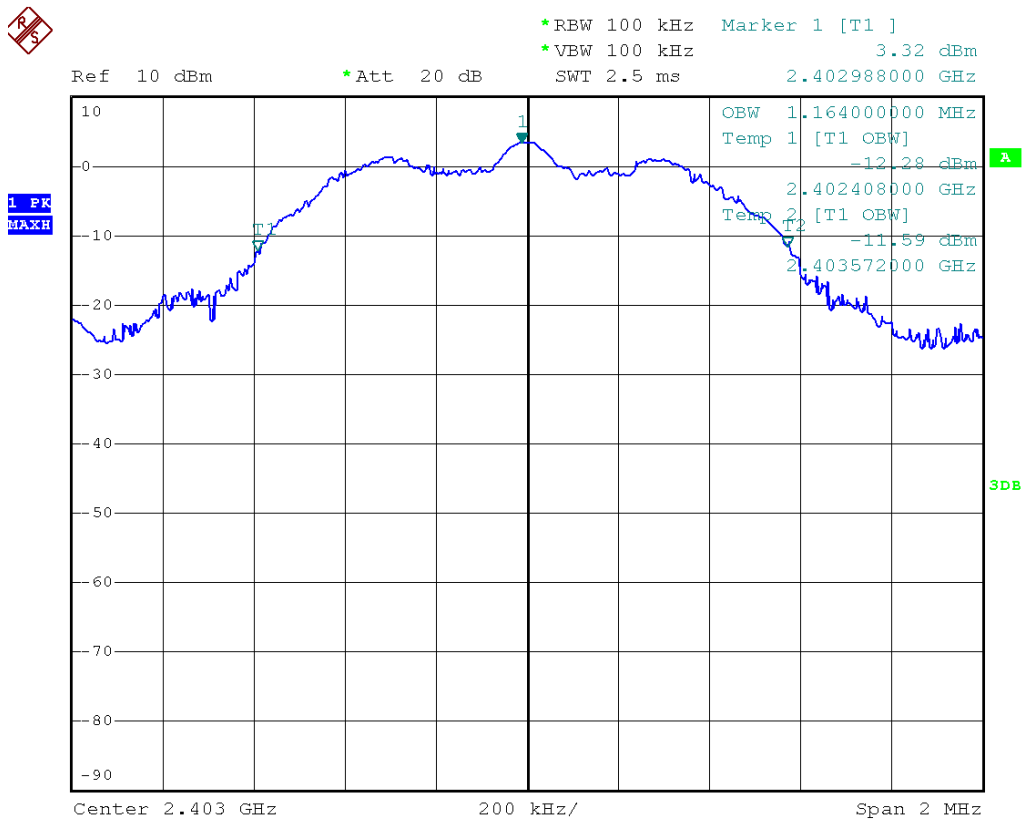

Figure 26- 99% Bandwidth measurement (fc=2442MHz)

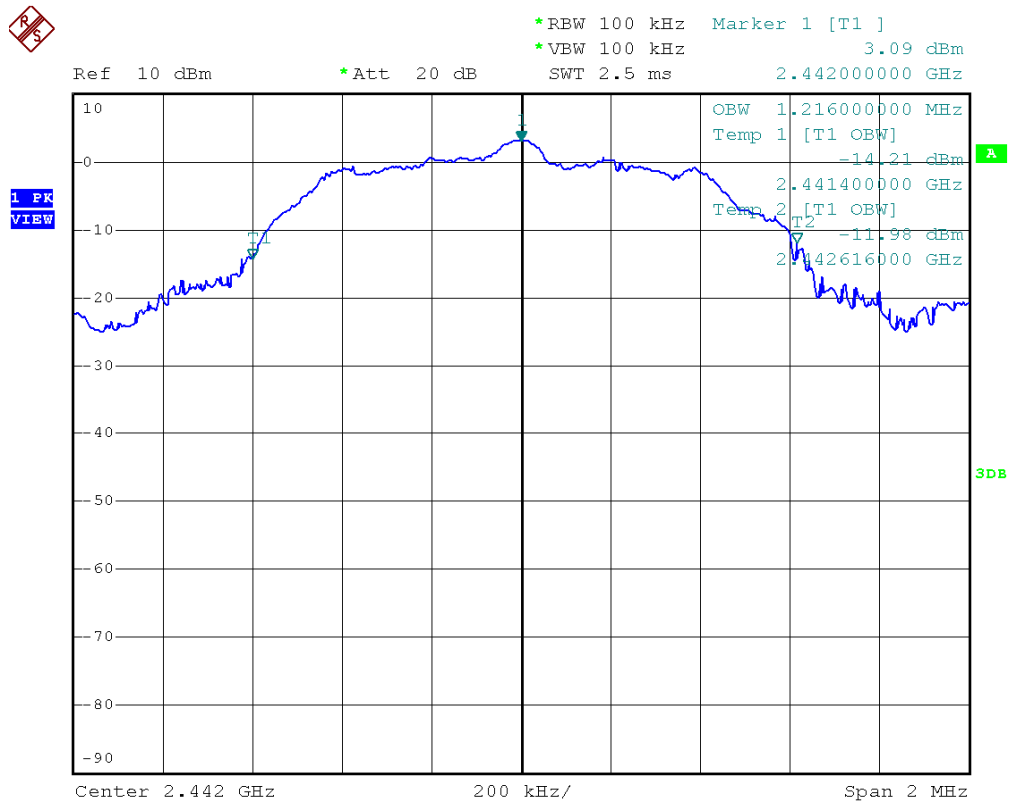
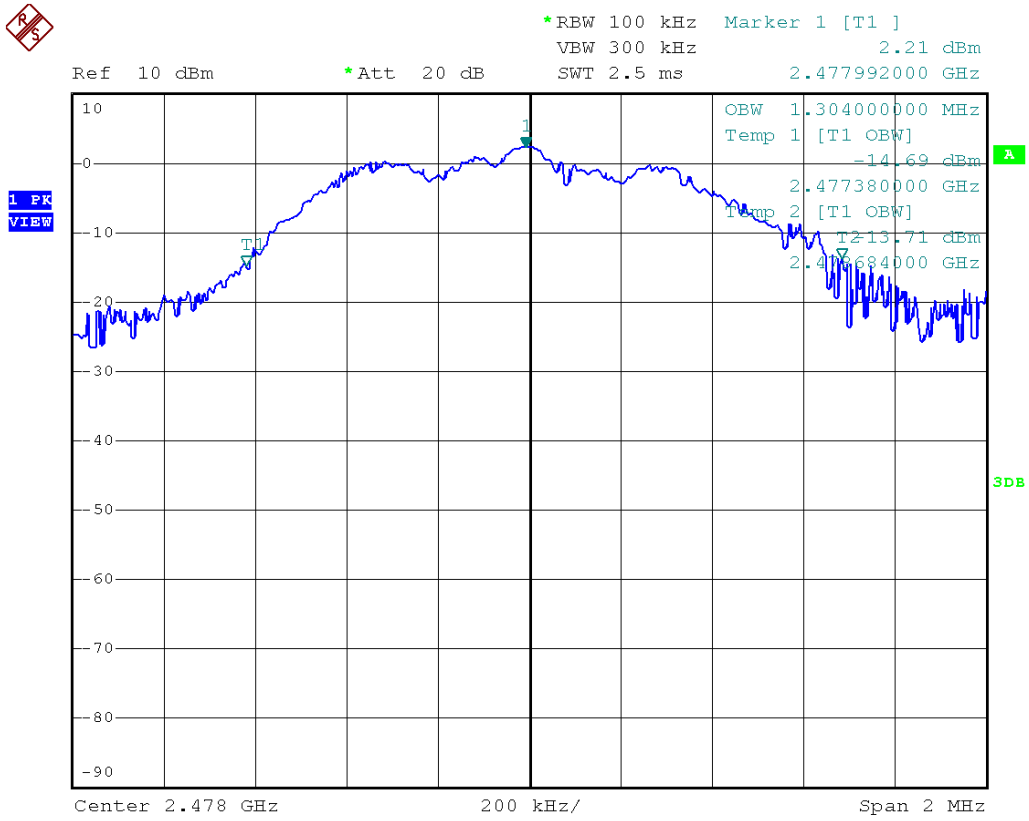

Figure 27- 99% Bandwidth measurement (fc=2478MHz)



6.10 RF Exposure

Standard Applicable

According to FCC part 15.247(i) and 1.1307 (b)(1), systems operating under the provisions of this section shall be operated in a manner that ensures that the public is not exposed to radio frequency energy levels in excess of the Commission's guidelines.

And for KDB 447498 SAR D01 General RF Exposure Guidance v05 Appendix B

SAR Test Exclusion Thresholds for 100 MHz – 6 GHz and > 50 mm

Approximate SAR test exclusion power thresholds at selected frequencies and test separation distances are illustrated in the following table.

MHz	50	60	70	80	90	100	110	120	130	140	150	160	170	180	190	mm
100	474	481	487	494	501	507	514	521	527	534	541	547	554	561	567	mW
150	387	397	407	417	427	437	447	457	467	477	487	497	507	517	527	
300	274	294	314	334	354	374	394	414	434	454	474	494	514	534	554	
450	224	254	284	314	344	374	404	434	464	494	524	554	584	614	644	
835	164	220	275	331	387	442	498	554	609	665	721	776	832	888	943	
900	158	218	278	338	398	458	518	578	638	698	758	818	878	938	998	
1500	122	222	322	422	522	622	722	822	922	1022	1122	1222	1322	1422	1522	
1900	109	209	309	409	509	609	709	809	909	1009	1109	1209	1309	1409	1509	
2450	96	196	296	396	496	596	696	796	896	996	1096	1196	1296	1396	1496	
3600	79	179	279	379	479	579	679	779	879	979	1079	1179	1279	1379	1479	
5200	66	166	266	366	466	566	666	766	866	966	1066	1166	1266	1366	1466	
5400	65	165	265	365	465	565	665	765	865	965	1065	1165	1265	1365	1465	
5800	62	162	262	362	462	562	662	762	862	962	1062	1162	1262	1362	1462	

According to RSS-102 Section 2.5.1, SAR evaluation is required if the separation distance between the user and the radiating element of the device is less than or equal to 20cm, except when the device operates above 2.2 GHz and up to 3 GHz inclusively, and with output power [i.e. the higher of the conducted or radiated (e.i.r.p.) source-based, time-averaged output power] that is less than or equal to 20 mW for general public use and 100 mW for controlled use.

Test Results:

For FCC evaluation, the peak output power 5.41dBm (3.48mW) is less than the corresponding SAR test exclusion power thresholds (96mW).

For IC evaluation, the peak output power 5.41dBm (3.48mW) is less than SAR test exclusion power thresholds (20mW) for general public use.

The unit does meet the requirements of SAR exemption.

6.11 Antenna Requirement

Standard Applicable

According to §15.203, an intentional radiator shall be designed to ensure that no antenna other than furnished by the responsible party shall be used with the device. And according to §15.246(1), if transmitting antennas of directional gain greater than 6dBi are used the power shall be reduced by the amount in dB that the directional gain of the antenna exceeds 6 dBi.

According to RSS-GEN 7.1.4, a transmitter can only be sold or operated with antennas with which it was certified. A transmitter may be certified with multiple antenna types. An antenna type comprises antennas having similar in-band and out-of-band radiation patterns. Testing shall be performed using the highest-gain antenna of each combination of transmitter and antenna type for which certification is being sought, with the transmitter output power set at the maximum level. Any antenna of the same type and having equal or lesser gain as an antenna that had been successfully tested for certification with the transmitter, will also be considered certified with the transmitter, and may be used and marketed with the transmitter. The manufacturer shall include with the application for certification a list of acceptable antenna types to be used with the transmitter.

Antenna Construction:

The directional gain of antenna used for transmitting is 1.8 dBi, and the antenna connector is designed with permanent attachment and no consideration of replacement. Please see EUT photo for details.

The unit does meet the requirement.