

FCC DFS Test Report

Tested in accordance with
Federal Communications Commission (FCC)
Personal Communications Services
CFR 47, Parts 15.407



REPORT NO.: RTS-6046-1308-12B

PRODUCT MODEL NO.: RFW121LW, RFV121LW
TYPE NAME: BlackBerry® smartphone
FCC ID: L6ARFW120LW, L6ARFV120LW

DATE: October 18, 2013

RTS is accredited
according to
EN ISO/IEC 17025 by:



592

 BlackBerry.	DFS Test Report for the BlackBerry® smartphone Model RFW121LW, RFV121LW	
Test Report No. RTS-6046-1308-12B	Date of Test July 11, 16 and 29, 2013	FCC ID: L6ARFW120LW, L6ARFV120LW

Statement of Performance:

The BlackBerry® smartphone, model RFW121LW, part number CER-54733-001 Rev2-x08-00 and accessories perform within the requirements of the test standards when configured and operated per Blackberry’s operation instructions.

The BlackBerry® smartphone, model RFV121LW, part number CER 54734-001 Rev 2-x08-00 and accessories perform within the requirements of the test standards when configured and operated per Blackberry’s operation instructions.

Declaration:

We hereby certify that:

The test data reported herein is an accurate record of the performance of the sample(s) tested.

The test results are valid for the tested unit (s) only.

The test equipment used was suitable for the tests performed and within manufacturer’s published specifications and operating parameters.

The test methods were consistent with the methods described in the relevant standards.

Documented by:

Reviewed by:

Heng Lin
Regulatory Compliance Specialist

Savtej S. Sandhu
Regulatory Compliance Specialist

Reviewed and Approved by:

Masud S. Attayi, P.Eng.
Manager, Regulatory Compliance



	DFS Test Report for the BlackBerry® smartphone Model RFW121LW, RFV121LW	
Test Report No. RTS-6046-1308-12B	Date of Test July 11, 16 and 29, 2013	FCC ID: L6ARFW120LW, L6ARFV120LW

Table of Contents

A.	Scope	4
B.	Associated Documents.....	4
C.	Product Identification	4
D.	Support Equipment Used for the Testing of the EUT	5
E.	Test Results Chart – FCC Part 15, Client Device.....	6
F.	Summary of Result.....	6
G.	Compliance Test Equipment Used	7
H.	Test Software used.....	7
APPENDIX 1 - DFS TEST PLOTS and DATA		8

	DFS Test Report for the BlackBerry® smartphone Model RFW121LW, RFV121LW	
Test Report No. RTS-6046-1308-12B	Date of Test July 11, 16 and 29, 2013	FCC ID: L6ARFW120LW, L6ARFV120LW

A. Scope

This report details the results of compliance tests that were performed in accordance with the requirements of:

- FCC CFR 47 Part 15.407, October, 2012

B. Associated Documents

1. BlackBerry_System_Similarity_Declaration_A-series_Rev1.2

C. Product Identification

Manufactured by BlackBerry Limited whose headquarters is located at:
 295 Phillip Street
 Waterloo, Ontario
 Canada, N2L 3W8
 Phone: 519 888 7465
 Fax: 519 888 6906

The equipment under test (EUT) was tested at the following locations:

RTS Test Facility
 440 Phillip Street
 Waterloo, Ontario
 Canada, N2L 5R9
 Phone: 519 888 7465
 Fax: 519 888 6906

The testing was performed on July 11, 16 and 29, 2013.

	DFS Test Report for the BlackBerry® smartphone Model RFW121LW, RFV121LW	
Test Report No. RTS-6046-1308-12B	Date of Test July 11, 16 and 29, 2013	FCC ID: L6ARFW120LW, L6ARFV120LW

BlackBerry® smartphone Samples Tested

SAMPLE	MODEL	CER NUMBER	PIN	SOFTWARE
1	RFW121LW	CER-54733-001 Rev2-x08-00	2FFFE45B	10.2.0.519

DFS testing was performed on sample 1.

As per manufacture's BlackBerry_System_Similarity_Declaration_A-series_Rev1.2 ,
There is no retesting impact applicable.
Changes between RFW121LW and RFV121LW did not impact the measurements.

The manufacturer declared modes for the EUT operational characteristics that affect DFS are as follows:

Operating Modes (5250 -5350 MHz, 5470-5725MHz)

- Master Device
- Client Device (no In-Service Monitoring, no Ad – Hoc mode)
- Client Device with In-Service Monitoring

Channel Protocol

- IP Based
- Frame Based
- Other _____

D. Support Equipment Used for the Testing of the EUT

Manufacturer	Description	Model	Serial Number	FCC ID and IC
Cisco	Access Point	AIR-RM1252G-A-K9	FCW1336Z03R	LDK102061/2 2461B-102061/2
Lenovo	Laptop	8742-C2U	L3-B3615 07/06	MCLJ07H081 2878D-J07H081
D-Link	Router	WBR-1310	P10317B010096	KA2WBR1310 4216A-WBR1310

	DFS Test Report for the BlackBerry® smartphone Model RFW121LW, RFV121LW	
Test Report No. RTS-6046-1308-12B	Date of Test July 11, 16 and 29, 2013	FCC ID: L6ARFW120LW, L6ARFV120LW

E. Test Results Chart – FCC Part 15, Client Device

SPECIFICATION	TEST TYPE	Meets Requirement	Test Data APPENDIX
FCC CFR 47			
Part 15.407	Channel closing transmission time	Yes	1
Part 15.407	Channel move time	Yes	1
Part 15.407	Non-occupancy period - associated	Yes	1

F. Summary of Result

The following tests were performed on model RFW121LW. The IC compliance reference is applicable only to model RFY111LW.

- a). The BlackBerry® smartphone met the requirement of the Channel Closing Transmission and Time, Channel Move time and Non-occupancy period requirement as per FCC 15.407 and RSS 210. The measurement was performed on Channel 60 (5300 MHz) of the DFS band. Radar Type 1 of the Short Pulse Test waveform was used for tests.

See APPENDIX 1 for the test data.

Measurement Uncertainties:

Measurement	Measurement Unit	Expanded Uncertainty
DFS Threshold (Conducted)	dBm	1.2

	DFS Test Report for the BlackBerry® smartphone Model RFW121LW, RFV121LW	
Test Report No. RTS-6046-1308-12B	Date of Test July 11, 16 and 29, 2013	FCC ID: L6ARFW120LW, L6ARFV120LW

G. Compliance Test Equipment Used

<u>UNIT</u>	<u>MANUFACTURER</u>	<u>MODEL</u>	<u>SERIAL NUMBER</u>	<u>CAL DUE DATE (YY MM DD)</u>	<u>USE</u>
Spectrum Analyzer	Rohde & Schwarz	FSV	101820	13-11-21	DFS
DFS RF Modulator	National Instruments	PXIe-5611	EC157C	14-02-25	DFS
DFS I/Q Signal Generator	National Instruments	PXIe-5450	EC6BB1	14-02-25	DFS
DFS RF Signal Generator	National Instruments	PXIe-5620	ED2167	14-02-25	DFS
T/RH Meter	OMEGA	iTHX-SD	0380564	13-10-30	DFS

H. Test Software used

<u>SOFTWARE</u>	<u>COMPANY</u>	<u>VERSION</u>	<u>USE</u>
iDFTest	Redwolf	2.5	DFS

APPENDIX 1 - DFS TEST PLOTS and DATA

BlackBerry	DFS Test Report for the BlackBerry® smartphone Model RFW121LW, RFV121LW APPENDIX 1	
Test Report No. RTS-6046-1308-12B	Date of Test July 11, 16 and 29, 2013	FCC ID: L6ARFW120LW, L6ARFV120LW

DFS Conducted Test Results

DFS Test Methods

Conducted Test Method

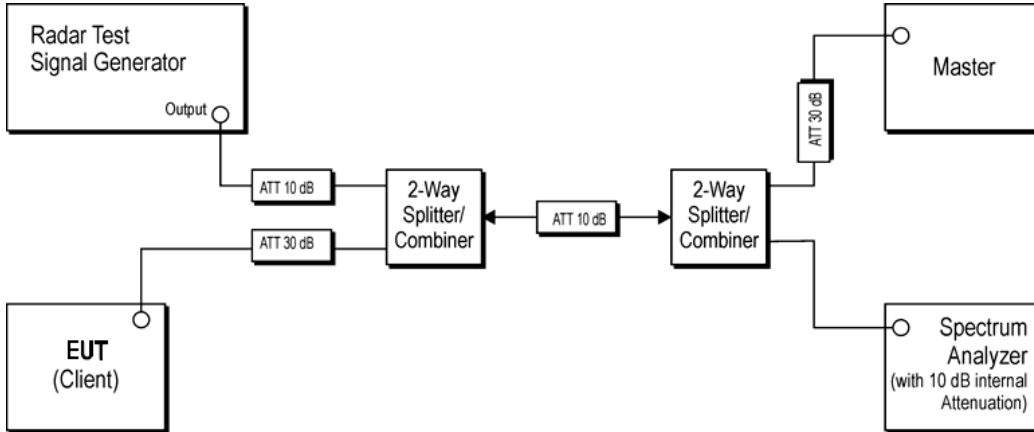

<u>UNIT</u>	<u>MANUFACTURER</u>	<u>MODEL</u>	<u>SERIAL NUMBER</u>
10dB Attenuator	Aeroflex Weinschel	3330A-10	-
30dB Attenuator	Aeroflex Weinschel	3330A-30	-
2-Way Splitter	Weinschel	1515	QC170
2-Way Splitter	Weinschel	1534	221

A spectrum analyzer is used as a monitor to verify that the EUT has vacated the Channel within the Channel Closing Transmission Time and Channel Move Time, and does not transmit on a Channel during the Non-Occupancy Period after the detection and Channel Move. It is also used to monitor EUT transmissions during the Channel Availability Check Time.

	DFS Test Report for the BlackBerry® smartphone Model RFW121LW, RFV121LW APPENDIX 1	
Test Report No. RTS-6046-1308-12B	Date of Test July 11, 16 and 29, 2013	FCC ID: L6ARFW120LW, L6ARFV120LW

DFS Conducted Test Results Cont'd

Radar Waveforms

FCC Short Pulse Radar Test Waveforms					
Radar Type	Pulse Width (µsec)	PRI (µsec)	Number of Pulses	Minimum Detection Percentage	Minimum Number of Trials
1	1	1428	18	60%	30
2	1-5	150-230	23-29	60%	30
3	6-10	200-500	16-18	60%	30
4	11-20	200-500	12-16	60%	30
Aggregate (Radar Types 1-4)				80%	120

FCC Long Pulse Radar Test Waveforms							
Radar Type	Pulse Width (µsec)	Chirp Width (MHz)	PRI (µs)	Number of Pulses per Burst	Number of Bursts	Minimum Detection Percentage	Minimum Number of Trials
5	50-100	5-20	1000-2000	1-3	8-20	80%	30

Frequency Hopping Radar Test Waveforms							
Radar Type	Pulse Width (µsec)	PRI (µsec)	Pulses per Hop	Hopping Rate (kHz)	Hopping Sequence Length (msec)	Minimum Detection Percentage	Minimum Number of Trials
6	1	333	9	0.333	300	70%	30

	DFS Test Report for the BlackBerry® smartphone Model RFW121LW, RFV121LW APPENDIX 1	
Test Report No. RTS-6046-1308-12B	Date of Test July 11, 16 and 29, 2013	FCC ID: L6ARFW120LW, L6ARFV120LW

DFS Conducted Test Results Cont'd

The test was performed on the model RFW121LW.

The following tests were performed by Heng Lin

Date of the test: July 11, 16 and 29, 2013

The environmental conditions were: Temperature: 23.6 – 24.7 °C
 Humidity: 22.9 – 49.5 %

Wave form Type	Channel Closing Transmission Time		Channel Move Time		Result
	Measured	Limit	Measured	Limit	
Radar Type 1	94.20 ms	260 ms	8.68 s	10 s	PASS

Channel Closing Transmission Time

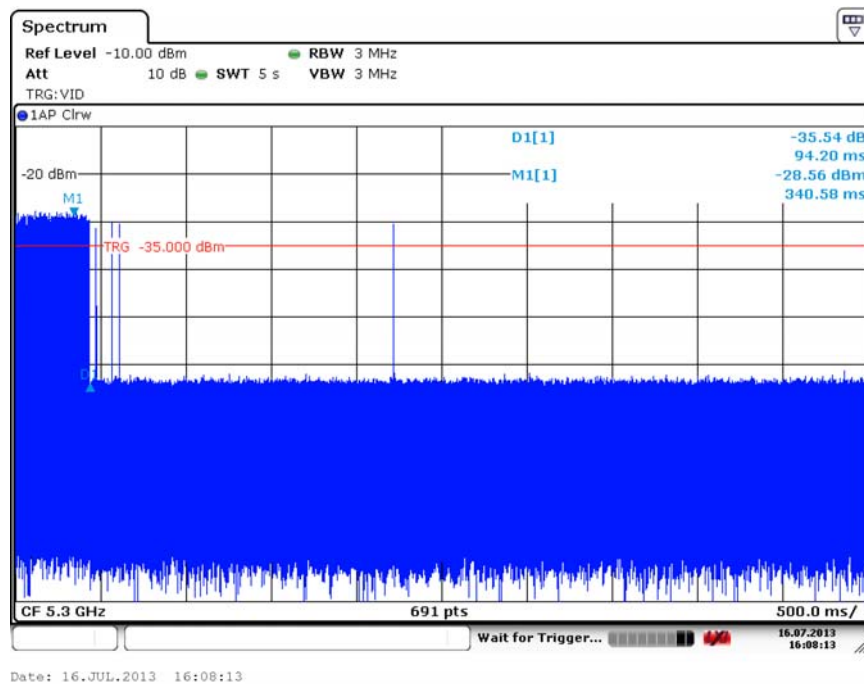

BlackBerry	DFS Test Report for the BlackBerry® smartphone Model RFW121LW, RFV121LW APPENDIX 1	
Test Report No. RTS-6046-1308-12B	Date of Test July 11, 16 and 29, 2013	FCC ID: L6ARFW120LW, L6ARFV120LW

DFS Conducted Test Results Cont'd

Channel Move Time

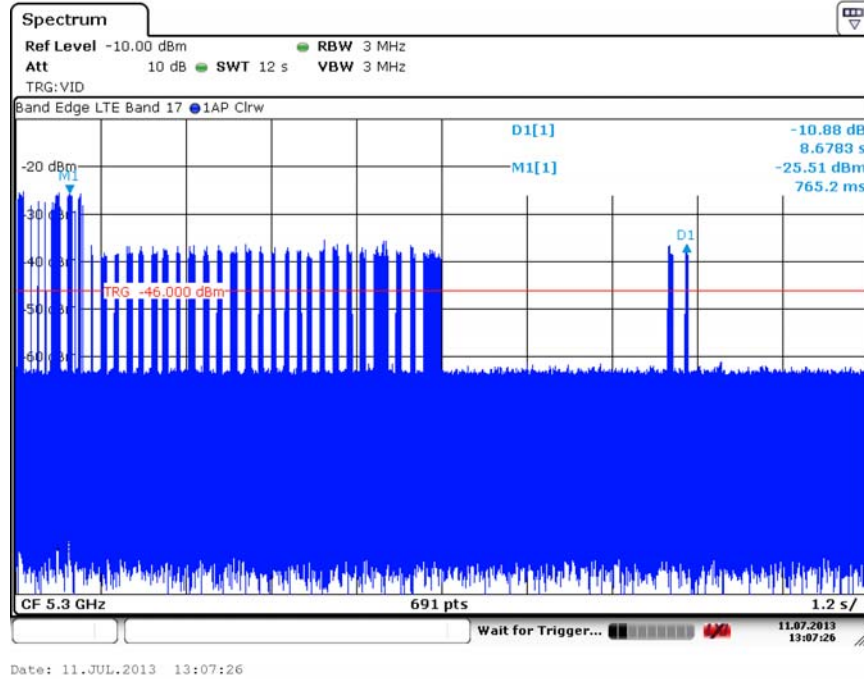

Non-Occupancy Period ≥ 30 min.

