	Document Appendix C2 for the BlackBerry® Smartphone Model REV71UW SAR Report			Page 1(64)
	Author Data Andrew Becker	Dates of Test February 06 – March 6 , 2012	Test Report No RTS-5992-1203-12	FCC ID: L6AREV70UW

APPENDIX C2: SAR DISTRIBUTION PLOTS FOR MOBILE HOT SPOT

	Document Appendix C2 for the BlackBerry® Smartphone Model REV71UW SAR Report			Page 2(64)
	Author Data Andrew Becker	Dates of Test February 06 – March 6 , 2012	Test Report No RTS-5992-1203-12	FCC ID: L6AREV70UW

Date/Time: 2/24/2012 11:10:34 PM

Test Laboratory: RIM Testing Services

MHS_Back_GPRS850_mid_chan_amb_temp_22.9C_liq_temp_20.0C

DUT: BlackBerry Smartphone; Type: Sample ; Serial: 295EC578

Communication System: GPRS 850; Frequency: 836.8 MHz

Medium parameters used (interpolated): $f = 836.8$ MHz; $\sigma = 0.975$ mho/m; $\epsilon_r = 54.362$; $\rho = 1000$ kg/m³

Phantom section: Flat Section

Measurement Standard: DASYS (IEEE/IEC/ANSI C63.19-2007)

DASY Configuration:

- Probe: ES3DV3 - SN3225; ConvF(6.07, 6.07, 6.07); Calibrated: 1/11/2012
- Sensor-Surface: 3mm (Mechanical Surface Detection), $z = 2.0, 32.0$
- Electronics: DAE3 Sn473; Calibrated: 1/13/2012
- Phantom: SAM 2; Type: SAM 4.0; Serial: 1080
- DASYS 52.8.0(692); SEMCAD X 14.6.4(4989)

Configuration/Touch position -/Area Scan (61x91x1): Measurement grid:
 $dx=15$ mm, $dy=15$ mm

[Info: Interpolated medium parameters used for SAR evaluation.](#)

Maximum value of SAR (interpolated) = 0.778 mW/g

Configuration/Touch position -/Zoom Scan (5x5x7) (5x7x7)/Cube 0:

Measurement grid: $dx=7.5$ mm, $dy=7.5$ mm, $dz=5$ mm

Reference Value = 27.246 V/m; Power Drift = -0.02 dB

Peak SAR (extrapolated) = 0.9180

SAR(1 g) = 0.704 mW/g; SAR(10 g) = 0.509 mW/g

[Info: Interpolated medium parameters used for SAR evaluation.](#)

Maximum value of SAR (measured) = 0.780 mW/g

Author Data
Andrew Becker

Dates of Test
February 06 – March 6 , 2012

Test Report No
RTS-5992-1203-12

FCC ID:
L6AREV70UW

IC ID
2503A-REV70UW

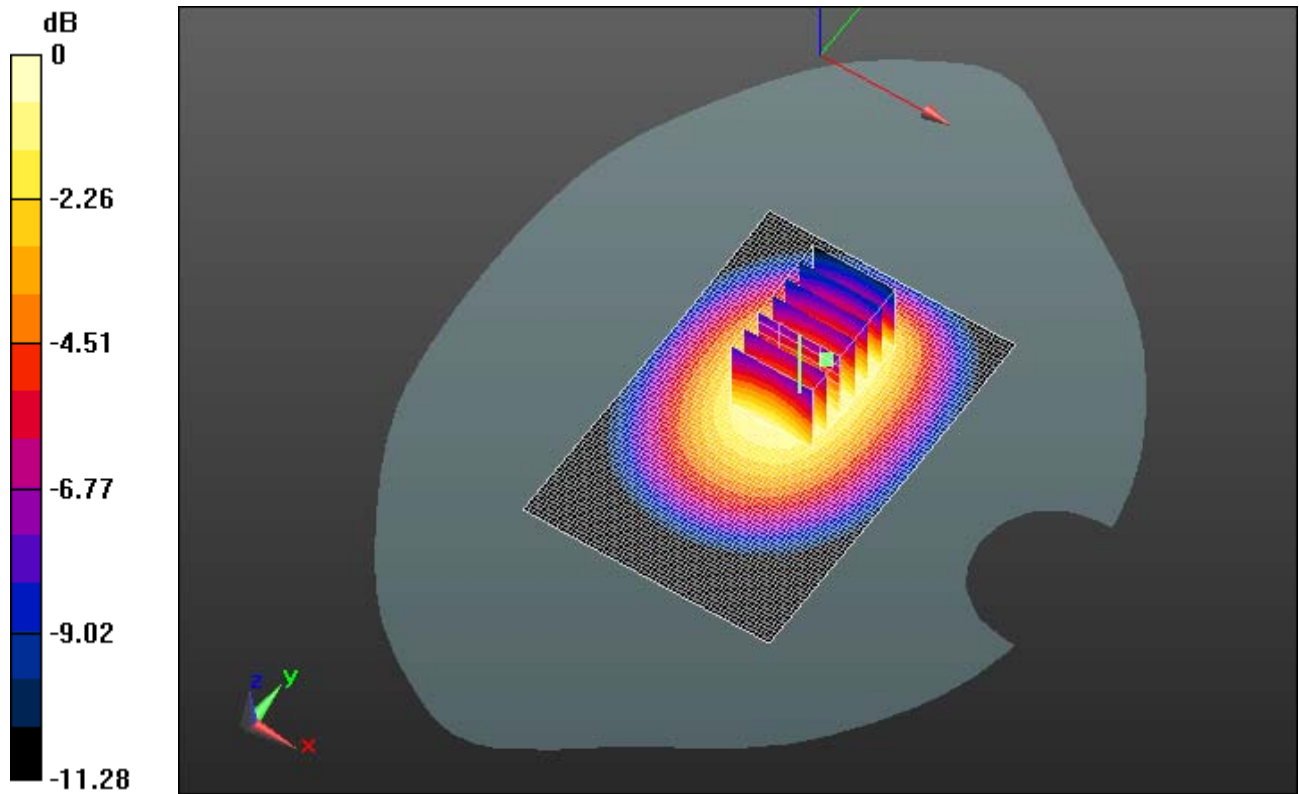

0 dB = 0.780mW/g = -2.16 dB mW/g

	Document Appendix C2 for the BlackBerry® Smartphone Model REV71UW SAR Report			Page 4(64)
	Author Data Andrew Becker	Dates of Test February 06 – March 6 , 2012	Test Report No RTS-5992-1203-12	FCC ID: L6AREV70UW

Date/Time: 2/24/2012 11:32:33 PM

Test Laboratory: RIM Testing Services

MHS_Front_GPRS850_mid_chan_amb_temp_23.0C_liq_temp_20.0C

DUT: BlackBerry Smartphone; Type: Sample ; Serial: 295EC578

Communication System: GPRS 850; Frequency: 836.8 MHz

Medium parameters used (interpolated): $f = 836.8$ MHz; $\sigma = 0.975$ mho/m; $\epsilon_r = 54.362$; $\rho = 1000$ kg/m³

Phantom section: Flat Section

Measurement Standard: DASYS (IEEE/IEC/ANSI C63.19-2007)

DASY Configuration:

- Probe: ES3DV3 - SN3225; ConvF(6.07, 6.07, 6.07); Calibrated: 1/11/2012
- Sensor-Surface: 3mm (Mechanical Surface Detection), $z = 2.0, 32.0$
- Electronics: DAE3 Sn473; Calibrated: 1/13/2012
- Phantom: SAM 2; Type: SAM 4.0; Serial: 1080
- DASYS 52.8.0(692); SEMCAD X 14.6.4(4989)

Configuration/Touch position -/Area Scan (61x91x1): Measurement grid:
 $dx=15$ mm, $dy=15$ mm

[Info: Interpolated medium parameters used for SAR evaluation.](#)

Maximum value of SAR (interpolated) = 0.640 mW/g

Configuration/Touch position -/Zoom Scan (5x5x7) (5x5x7)/Cube 0:

Measurement grid: $dx=7.5$ mm, $dy=7.5$ mm, $dz=5$ mm

Reference Value = 24.547 V/m; Power Drift = 0.11 dB

Peak SAR (extrapolated) = 0.7300

SAR(1 g) = 0.579 mW/g; SAR(10 g) = 0.434 mW/g

[Info: Interpolated medium parameters used for SAR evaluation.](#)

Maximum value of SAR (measured) = 0.634 mW/g

Author Data
Andrew Becker

Dates of Test
February 06 – March 6 , 2012

Test Report No
RTS-5992-1203-12

FCC ID:
L6AREV70UW

IC ID
2503A-REV70UW

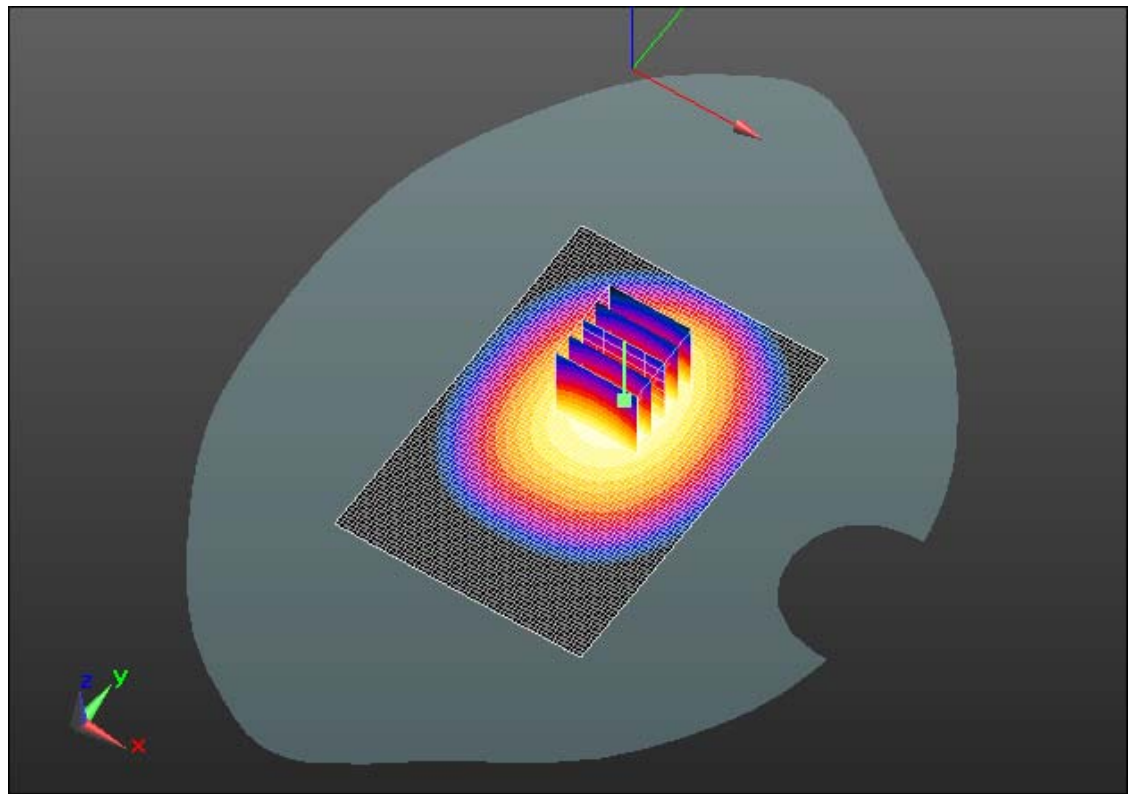
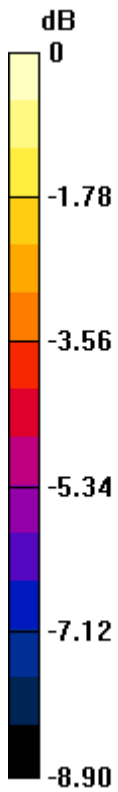

0 dB = 0.630mW/g = -4.01 dB mW/g

	Document Appendix C2 for the BlackBerry® Smartphone Model REV71UW SAR Report			Page 6(64)
	Author Data Andrew Becker	Dates of Test February 06 – March 6 , 2012	Test Report No RTS-5992-1203-12	FCC ID: L6AREV70UW

Date/Time: 2/27/2012 11:13:50 AM

Test Laboratory: RIM Testing Services

MHS_Right_GPRS850_mid_chan_amb_temp_22.7C_liq_temp_21.4C

DUT: BlackBerry Smartphone; Type: Sample ; Serial: 295EC578

Communication System: GPRS 850; Frequency: 836.8 MHz

Medium parameters used (interpolated): $f = 836.8$ MHz; $\sigma = 0.978$ mho/m; $\epsilon_r = 54.63$; $\rho = 1000$ kg/m³

Phantom section: Flat Section

Measurement Standard: DASYS (IEEE/IEC/ANSI C63.19-2007)

DASY Configuration:

- Probe: ES3DV3 - SN3225; ConvF(6.07, 6.07, 6.07); Calibrated: 1/11/2012
- Sensor-Surface: 3mm (Mechanical Surface Detection), $z = 2.0, 32.0$
- Electronics: DAE3 Sn473; Calibrated: 1/13/2012
- Phantom: SAM 2; Type: SAM 4.0; Serial: 1080
- DASYS 52.8.0(692); SEMCAD X 14.6.4(4989)

Configuration/Touch position -/Area Scan (31x101x1): Measurement grid:
dx=15mm, dy=15mm

[Info: Interpolated medium parameters used for SAR evaluation.](#)

Maximum value of SAR (interpolated) = 0.471 mW/g

Configuration/Touch position -/Zoom Scan (5x5x7) (5x5x7)/Cube 0:

Measurement grid: dx=7.5mm, dy=7.5mm, dz=5mm

Reference Value = 21.542 V/m; Power Drift = 0.09 dB

Peak SAR (extrapolated) = 0.5900

SAR(1 g) = 0.415 mW/g; SAR(10 g) = 0.289 mW/g

[Info: Interpolated medium parameters used for SAR evaluation.](#)

Maximum value of SAR (measured) = 0.475 mW/g

	Document Appendix C2 for the BlackBerry® Smartphone Model REV71UW SAR Report			Page 7(64)
	Author Data Andrew Becker	Dates of Test February 06 – March 6 , 2012	Test Report No RTS-5992-1203-12	FCC ID: L6AREV70UW

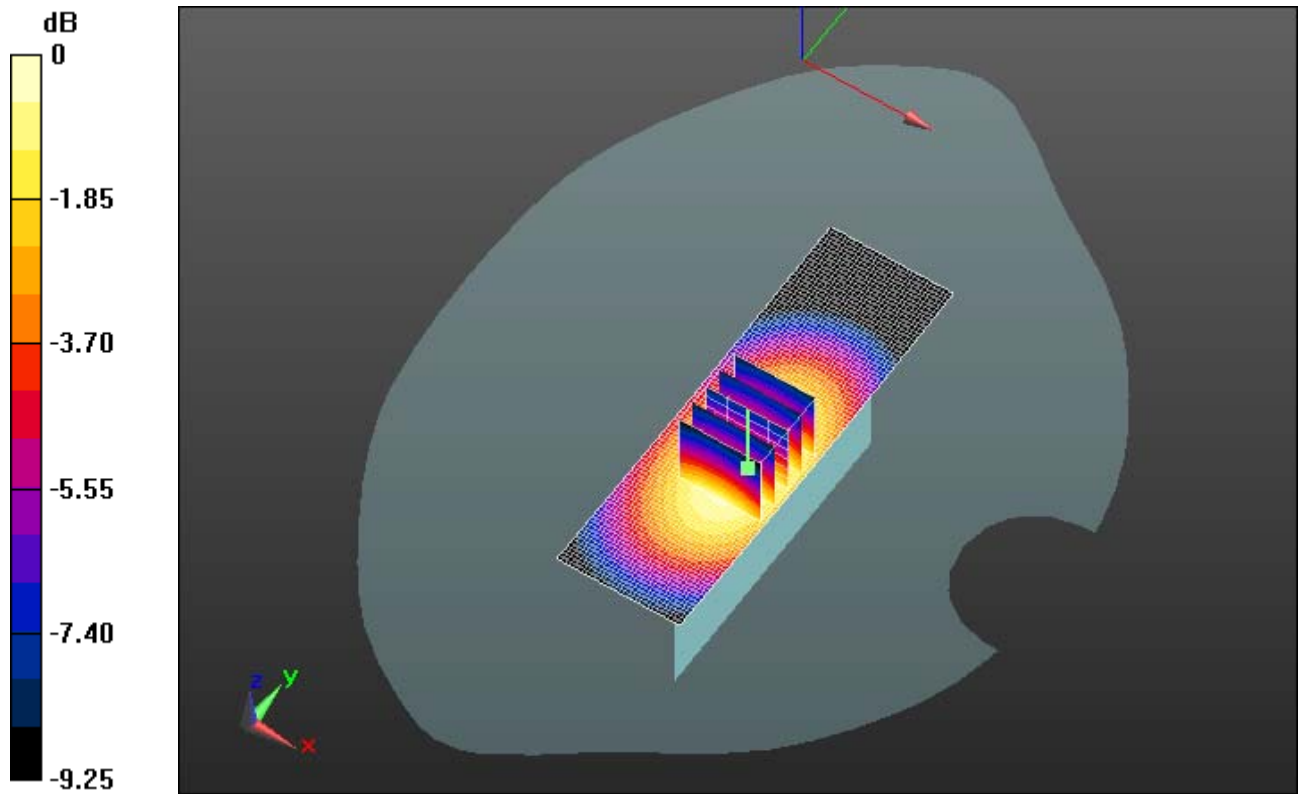

0 dB = 0.470mW/g = -6.56 dB mW/g

	Document Appendix C2 for the BlackBerry® Smartphone Model REV71UW SAR Report			Page 8(64)
	Author Data Andrew Becker	Dates of Test February 06 – March 6 , 2012	Test Report No RTS-5992-1203-12	FCC ID: L6AREV70UW

Date/Time: 2/27/2012 10:57:27 AM

Test Laboratory: RIM Testing Services

MHS_Left_GPRS850_mid_chan_amb_temp_22.7C_liq_temp_21.4C

DUT: BlackBerry Smartphone; Type: Sample ; Serial: 295EC578

Communication System: GPRS 850; Frequency: 836.8 MHz

Medium parameters used (interpolated): $f = 836.8$ MHz; $\sigma = 0.978$ mho/m; $\epsilon_r = 54.63$; $\rho = 1000$ kg/m³

Phantom section: Flat Section

Measurement Standard: DASYS (IEEE/IEC/ANSI C63.19-2007)

DASY Configuration:

- Probe: ES3DV3 - SN3225; ConvF(6.07, 6.07, 6.07); Calibrated: 1/11/2012
- Sensor-Surface: 3mm (Mechanical Surface Detection), $z = 2.0, 32.0$
- Electronics: DAE3 Sn473; Calibrated: 1/13/2012
- Phantom: SAM 2; Type: SAM 4.0; Serial: 1080
- DASYS 52.8.0(692); SEMCAD X 14.6.4(4989)

Configuration/Touch position -/Area Scan (31x101x1): Measurement grid:
dx=15mm, dy=15mm

[Info: Interpolated medium parameters used for SAR evaluation.](#)

Maximum value of SAR (interpolated) = 0.454 mW/g

Configuration/Touch position -/Zoom Scan (5x5x7) (5x5x7)/Cube 0:

Measurement grid: dx=7.5mm, dy=7.5mm, dz=5mm

Reference Value = 22.215 V/m; Power Drift = 0.0016 dB

Peak SAR (extrapolated) = 0.5720

SAR(1 g) = 0.405 mW/g; SAR(10 g) = 0.280 mW/g

[Info: Interpolated medium parameters used for SAR evaluation.](#)

Maximum value of SAR (measured) = 0.467 mW/g

	Document Appendix C2 for the BlackBerry® Smartphone Model REV71UW SAR Report			Page 9(64)
	Author Data Andrew Becker	Dates of Test February 06 – March 6 , 2012	Test Report No RTS-5992-1203-12	FCC ID: L6AREV70UW

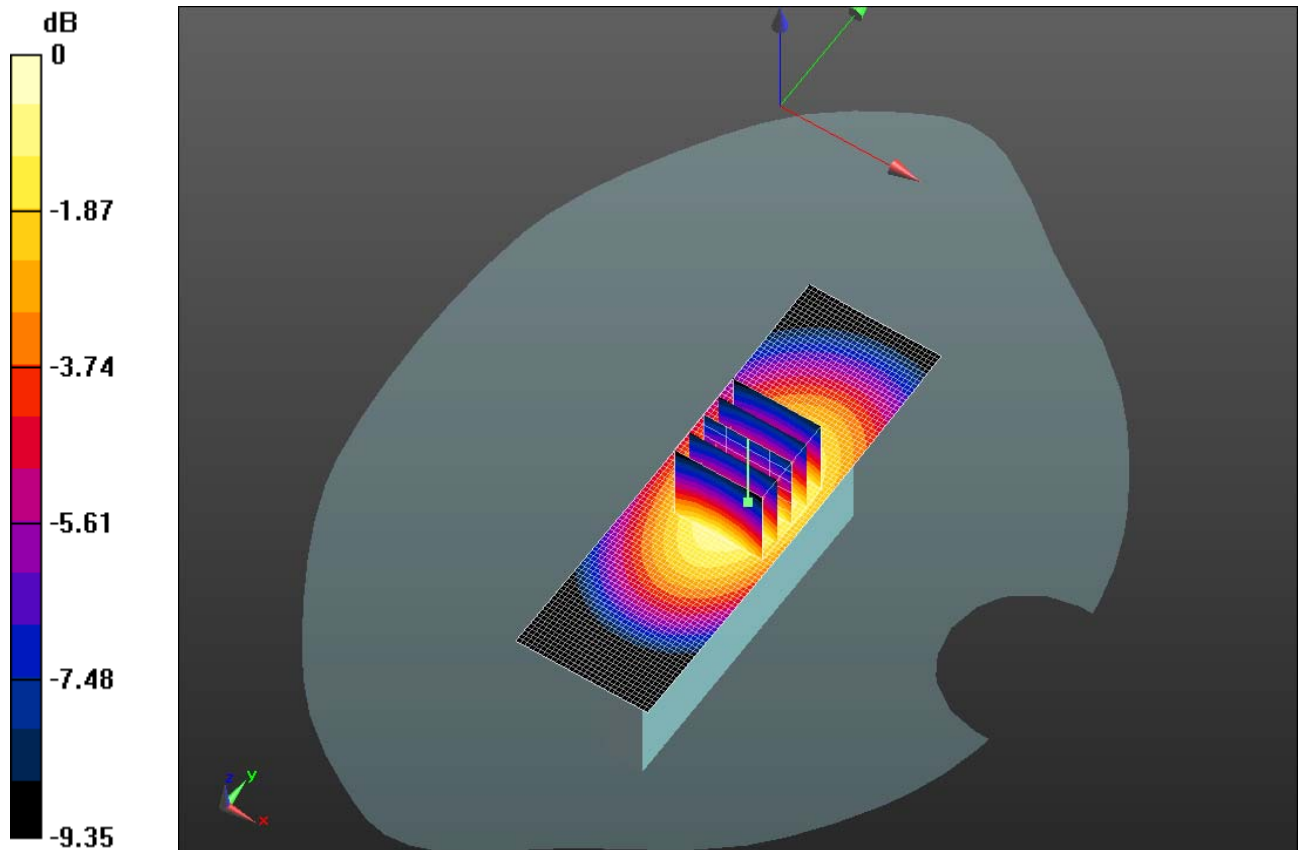

0 dB = 0.470mW/g = -6.56 dB mW/g

	Document Appendix C2 for the BlackBerry® Smartphone Model REV71UW SAR Report			Page 10(64)
	Author Data Andrew Becker	Dates of Test February 06 – March 6 , 2012	Test Report No RTS-5992-1203-12	FCC ID: L6AREV70UW

Date/Time: 2/27/2012 11:31:44 AM

Test Laboratory: RIM Testing Services

MHS_Bottom_GPRS850_mid_chan_amb_temp_23.1C_liq_temp_21.4C

DUT: BlackBerry Smartphone; Type: Sample ; Serial: 295EC578

Communication System: GPRS 850; Frequency: 836.8 MHz

Medium parameters used (interpolated): $f = 836.8$ MHz; $\sigma = 0.978$ mho/m; $\epsilon_r = 54.63$; $\rho = 1000$ kg/m³

Phantom section: Flat Section

Measurement Standard: DASYS (IEEE/IEC/ANSI C63.19-2007)

DASY Configuration:

- Probe: ES3DV3 - SN3225; ConvF(6.07, 6.07, 6.07); Calibrated: 1/11/2012
- Sensor-Surface: 3mm (Mechanical Surface Detection), $z = 2.0, 32.0$
- Electronics: DAE3 Sn473; Calibrated: 1/13/2012
- Phantom: SAM 2; Type: SAM 4.0; Serial: 1080
- DASYS 52.8.0(692); SEMCAD X 14.6.4(4989)

Configuration/Touch position -/Area Scan (31x81x1): Measurement grid:
dx=15mm, dy=15mm

[Info: Interpolated medium parameters used for SAR evaluation.](#)

Maximum value of SAR (interpolated) = 0.071 mW/g

Configuration/Touch position -/Zoom Scan (5x5x7) (6x6x7)/Cube 0:

Measurement grid: dx=7.5mm, dy=7.5mm, dz=5mm

Reference Value = 8.061 V/m; Power Drift = -0.06 dB

Peak SAR (extrapolated) = 0.1090

SAR(1 g) = 0.064 mW/g; SAR(10 g) = 0.042 mW/g

[Info: Interpolated medium parameters used for SAR evaluation.](#)

Maximum value of SAR (measured) = 0.068 mW/g

Author Data
Andrew Becker

Dates of Test
February 06 – March 6 , 2012

Test Report No
RTS-5992-1203-12

FCC ID:
L6AREV70UW

IC ID
2503A-REV70UW

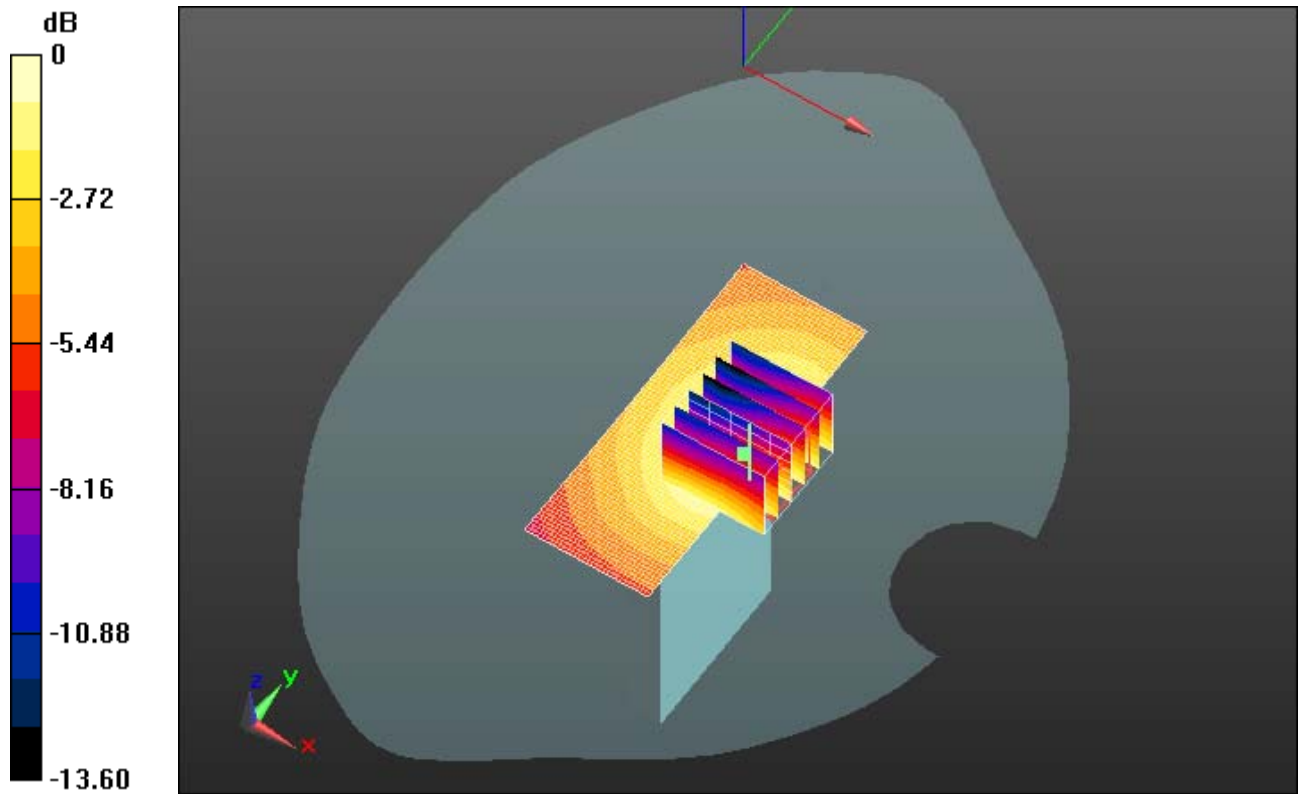

0 dB = 0.070mW/g = -23.10 dB mW/g

	Document Appendix C2 for the BlackBerry® Smartphone Model REV71UW SAR Report			Page 12(64)
	Author Data Andrew Becker	Dates of Test February 06 – March 6 , 2012	Test Report No RTS-5992-1203-12	FCC ID: L6AREV70UW

Date/Time: 2/10/2012 3:57:21 PM

Test Laboratory: RIM Testing Services

MHS_Back_UMTS_Band_V_mid_chan_amb_temp_23.0C_liq_temp_20.3C

DUT: BlackBerry Smartphone; Type: Sample ; Serial: 295EC578

Communication System: WCDMA FDD V; Frequency: 836.4 MHz

Medium parameters used (interpolated): $f = 836.4$ MHz; $\sigma = 0.996$ mho/m; $\epsilon_r = 55.769$; $\rho = 1000$ kg/m³

Phantom section: Flat Section

Measurement Standard: DASYS (IEEE/IEC/ANSI C63.19-2007)

DASY Configuration:

- Probe: ES3DV3 - SN3225; ConvF(6.07, 6.07, 6.07); Calibrated: 1/11/2012
- Sensor-Surface: 3mm (Mechanical Surface Detection), $z = 2.0, 32.0$
- Electronics: DAE3 Sn472; Calibrated: 3/7/2011
- Phantom: SAM 2; Type: SAM 4.0; Serial: 1080
- DASYS 52 52.8.0(692); SEMCAD X 14.6.4(4989)

Configuration/Touch position -/Area Scan (61x91x1): Measurement grid:
 $dx=15$ mm, $dy=15$ mm

[Info: Interpolated medium parameters used for SAR evaluation.](#)

Maximum value of SAR (interpolated) = 0.848 mW/g

Configuration/Touch position -/Zoom Scan (5x5x7) (6x7x7)/Cube 0:

Measurement grid: $dx=7.5$ mm, $dy=7.5$ mm, $dz=5$ mm

Reference Value = 28.029 V/m; Power Drift = -0.05 dB

Peak SAR (extrapolated) = 0.9780

SAR(1 g) = 0.715 mW/g; SAR(10 g) = 0.515 mW/g

[Info: Interpolated medium parameters used for SAR evaluation.](#)

Maximum value of SAR (measured) = 0.798 mW/g

	Document Appendix C2 for the BlackBerry® Smartphone Model REV71UW SAR Report			Page 13(64)
	Author Data Andrew Becker	Dates of Test February 06 – March 6 , 2012	Test Report No RTS-5992-1203-12	FCC ID: L6AREV70UW

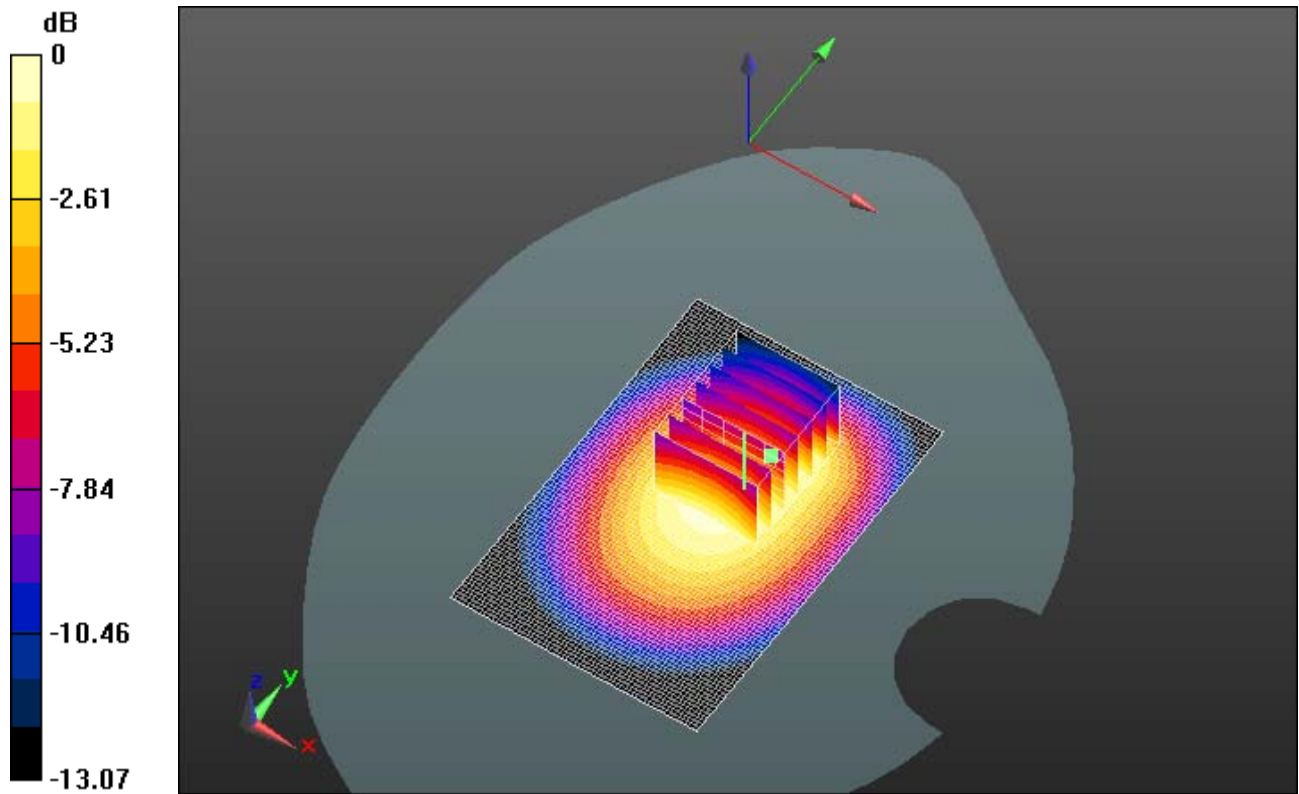

0 dB = 0.800mW/g = -1.94 dB mW/g

	Document Appendix C2 for the BlackBerry® Smartphone Model REV71UW SAR Report			Page 14(64)
	Author Data Andrew Becker	Dates of Test February 06 – March 6 , 2012	Test Report No RTS-5992-1203-12	FCC ID: L6AREV70UW

Date/Time: 2/10/2012 4:18:04 PM

Test Laboratory: RIM Testing Services

MHS_Front_UMTS_Band_V_mid_chan_amb_temp_23.1C_liq_temp_20.3C

DUT: BlackBerry Smartphone; Type: Sample ; Serial: 295EC578

Communication System: WCDMA FDD V; Frequency: 836.4 MHz
Medium parameters used (interpolated): $f = 836.4$ MHz; $\sigma = 0.996$ mho/m; $\epsilon_r = 55.769$; $\rho = 1000$ kg/m³
Phantom section: Flat Section
Measurement Standard: DASYS (IEEE/IEC/ANSI C63.19-2007)

DASY Configuration:

- Probe: ES3DV3 - SN3225; ConvF(6.07, 6.07, 6.07); Calibrated: 1/11/2012
- Sensor-Surface: 3mm (Mechanical Surface Detection), $z = 2.0, 32.0$
- Electronics: DAE3 Sn472; Calibrated: 3/7/2011
- Phantom: SAM 2; Type: SAM 4.0; Serial: 1080
- DASYS 52 52.8.0(692); SEMCAD X 14.6.4(4989)

Configuration/Touch position -/Area Scan (61x91x1): Measurement grid:
 $dx=15$ mm, $dy=15$ mm

[Info: Interpolated medium parameters used for SAR evaluation.](#)

Maximum value of SAR (interpolated) = 0.597 mW/g

Configuration/Touch position -/Zoom Scan (5x5x7) (5x5x7)/Cube 0:

Measurement grid: $dx=7.5$ mm, $dy=7.5$ mm, $dz=5$ mm
Reference Value = 22.921 V/m; Power Drift = -0.0013 dB
Peak SAR (extrapolated) = 0.6930
SAR(1 g) = 0.539 mW/g; SAR(10 g) = 0.401 mW/g

[Info: Interpolated medium parameters used for SAR evaluation.](#)

Maximum value of SAR (measured) = 0.596 mW/g

Author Data
Andrew Becker

Dates of Test
February 06 – March 6 , 2012

Test Report No
RTS-5992-1203-12

FCC ID:
L6AREV70UW

IC ID
2503A-REV70UW

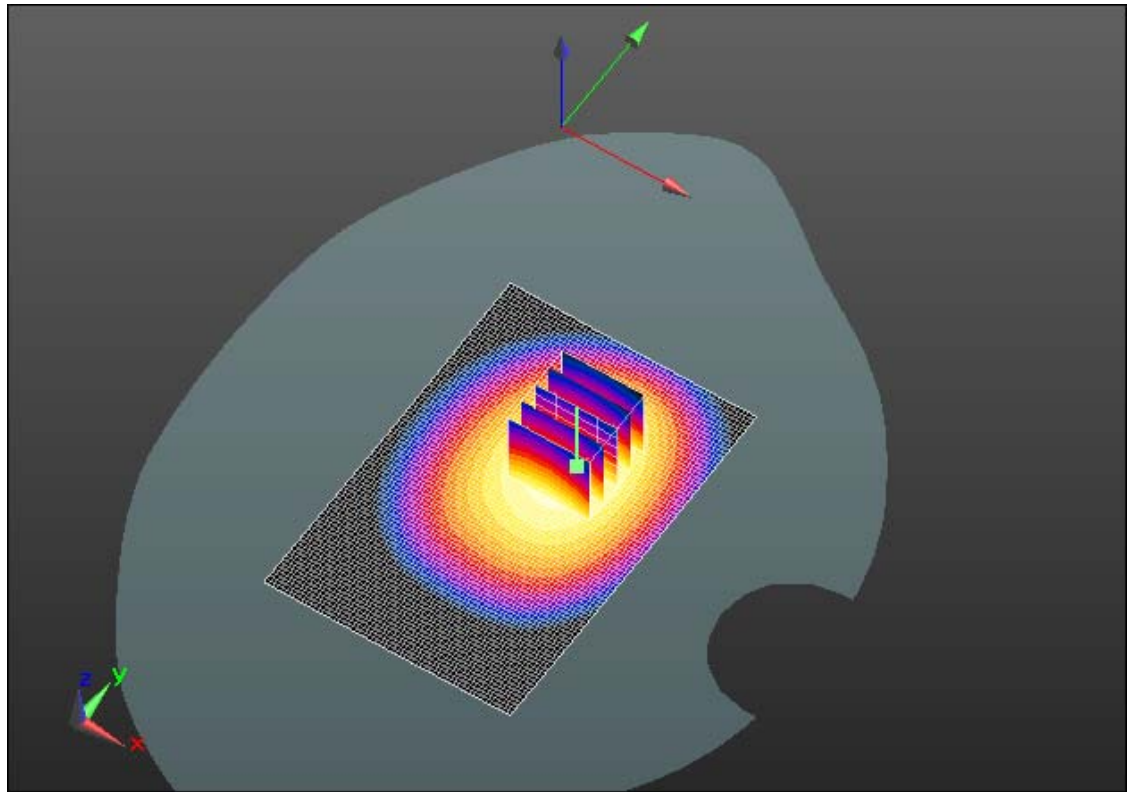
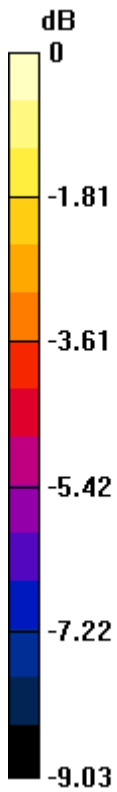

0 dB = 0.600mW/g = -4.44 dB mW/g

	Document Appendix C2 for the BlackBerry® Smartphone Model REV71UW SAR Report			Page 16(64)
	Author Data Andrew Becker	Dates of Test February 06 – March 6 , 2012	Test Report No RTS-5992-1203-12	FCC ID: L6AREV70UW

Date/Time: 2/13/2012 11:02:02 AM

Test Laboratory: RIM Testing Services

MHS_Right_UMTS_Band_V_mid_chan_amb_temp_22.6C_liq_temp_21.4C

DUT: BlackBerry Smartphone; Type: Sample ; Serial: 295EC578

Communication System: WCDMA FDD V; Frequency: 836.4 MHz

Medium parameters used (interpolated): $f = 836.4$ MHz; $\sigma = 0.978$ mho/m; $\epsilon_r = 55.036$; $\rho = 1000$ kg/m³

Phantom section: Flat Section

Measurement Standard: DASYS (IEEE/IEC/ANSI C63.19-2007)

DASY Configuration:

- Probe: ES3DV3 - SN3225; ConvF(6.07, 6.07, 6.07); Calibrated: 1/11/2012
- Sensor-Surface: 3mm (Mechanical Surface Detection), $z = 2.0, 32.0$
- Electronics: DAE3 Sn472; Calibrated: 3/7/2011
- Phantom: SAM 2; Type: SAM 4.0; Serial: 1080
- DASYS 52.8.0(692); SEMCAD X 14.6.4(4989)

Configuration/Touch position -/Area Scan (31x101x1): Measurement grid:
 $dx=15$ mm, $dy=15$ mm

[Info: Interpolated medium parameters used for SAR evaluation.](#)

Maximum value of SAR (interpolated) = 0.403 mW/g

Configuration/Touch position -/Zoom Scan (5x5x7) (5x5x7)/Cube 0:

Measurement grid: $dx=7.5$ mm, $dy=7.5$ mm, $dz=5$ mm

Reference Value = 20.646 V/m; Power Drift = -0.06 dB

Peak SAR (extrapolated) = 0.4890

SAR(1 g) = 0.355 mW/g; SAR(10 g) = 0.249 mW/g

[Info: Interpolated medium parameters used for SAR evaluation.](#)

Maximum value of SAR (measured) = 0.404 mW/g

Author Data
Andrew Becker

Dates of Test
February 06 – March 6 , 2012

Test Report No
RTS-5992-1203-12

FCC ID:
L6AREV70UW

IC ID
2503A-REV70UW

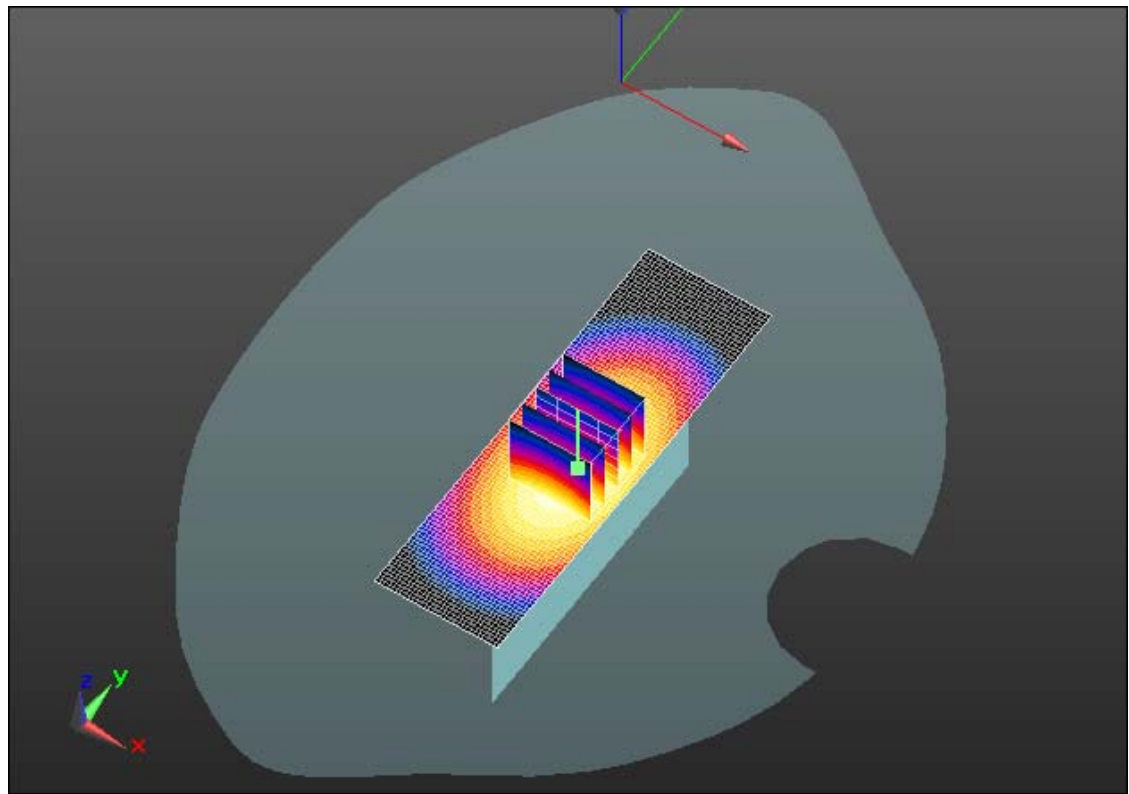
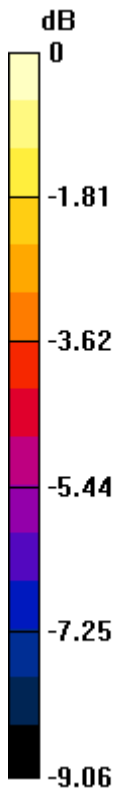

0 dB = 0.400mW/g = -7.96 dB mW/g

	Document Appendix C2 for the BlackBerry® Smartphone Model REV71UW SAR Report			Page 18(64)
	Author Data Andrew Becker	Dates of Test February 06 – March 6 , 2012	Test Report No RTS-5992-1203-12	FCC ID: L6AREV70UW

Date/Time: 2/13/2012 11:17:34 AM

Test Laboratory: RIM Testing Services

MHS_Left_UMTS_Band_V_mid_chan_amb_temp_22.9C_liq_temp_21.2 C

DUT: BlackBerry Smartphone; Type: Sample ; Serial: 295EC578

Communication System: WCDMA FDD V; Frequency: 836.4 MHz

Medium parameters used (interpolated): $f = 836.4$ MHz; $\sigma = 0.978$ mho/m; $\epsilon_r = 55.036$; $\rho = 1000$ kg/m³

Phantom section: Flat Section

Measurement Standard: DASYS (IEEE/IEC/ANSI C63.19-2007)

DASY Configuration:

- Probe: ES3DV3 - SN3225; ConvF(6.07, 6.07, 6.07); Calibrated: 1/11/2012
- Sensor-Surface: 3mm (Mechanical Surface Detection), $z = 2.0, 32.0$
- Electronics: DAE3 Sn472; Calibrated: 3/7/2011
- Phantom: SAM 2; Type: SAM 4.0; Serial: 1080
- DASYS 52.8.0(692); SEMCAD X 14.6.4(4989)

Configuration/Touch position -/Area Scan (31x101x1): Measurement grid:
 $dx=15$ mm, $dy=15$ mm

[Info: Interpolated medium parameters used for SAR evaluation.](#)

Maximum value of SAR (interpolated) = 0.400 mW/g

Configuration/Touch position -/Zoom Scan (5x5x7) (5x5x7)/Cube 0:

Measurement grid: $dx=7.5$ mm, $dy=7.5$ mm, $dz=5$ mm

Reference Value = 20.133 V/m; Power Drift = 0.01 dB

Peak SAR (extrapolated) = 0.4920

SAR(1 g) = 0.356 mW/g; SAR(10 g) = 0.248 mW/g

[Info: Interpolated medium parameters used for SAR evaluation.](#)

Maximum value of SAR (measured) = 0.405 mW/g

Author Data
Andrew Becker

Dates of Test
February 06 – March 6 , 2012

Test Report No
RTS-5992-1203-12

FCC ID:
L6AREV70UW

IC ID
2503A-REV70UW

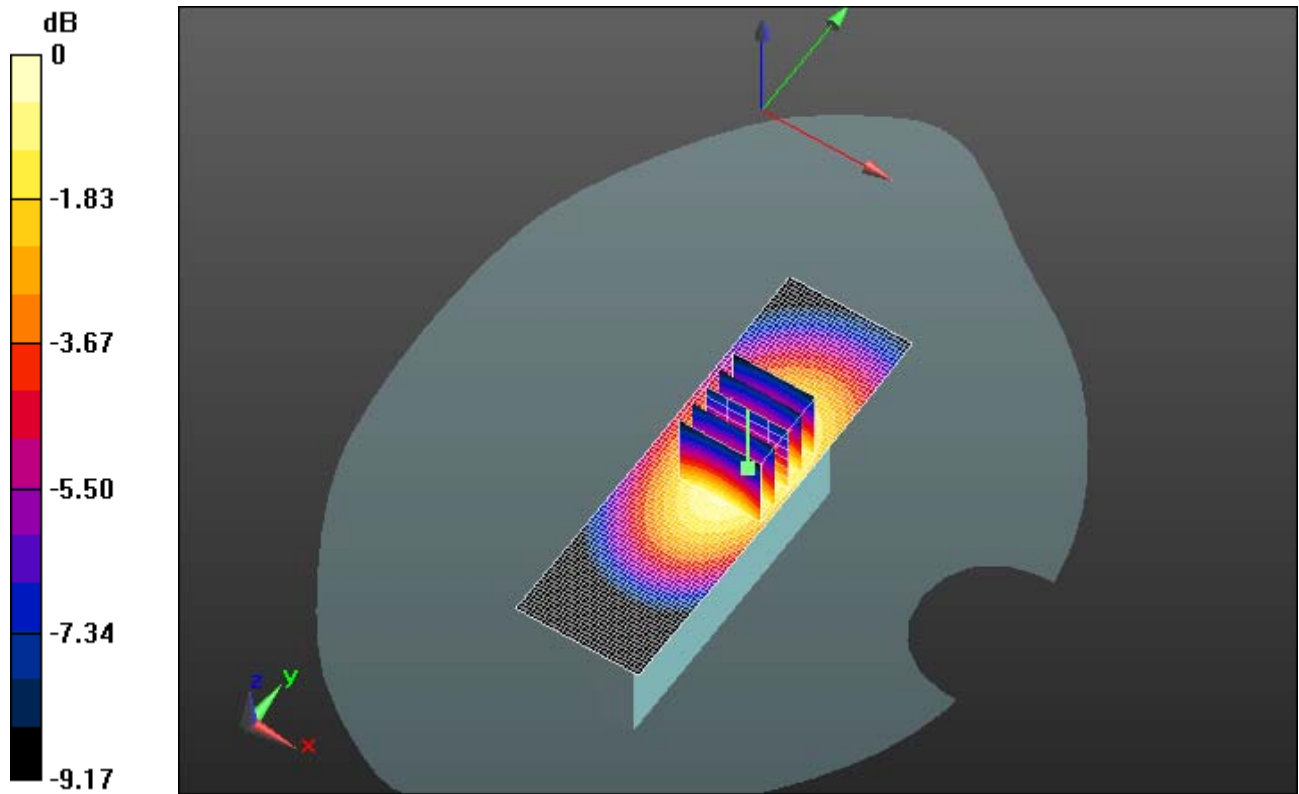

0 dB = 0.400mW/g = -7.96 dB mW/g

	Document Appendix C2 for the BlackBerry® Smartphone Model REV71UW SAR Report			Page 20(64)
	Author Data Andrew Becker	Dates of Test February 06 – March 6 , 2012	Test Report No RTS-5992-1203-12	FCC ID: L6AREV70UW

Date/Time: 2/13/2012 11:51:40 AM

Test Laboratory: RIM Testing Services

MHS_Bottom_UMTS_Band_V_mid_chan_amb_temp_22.9C_liq_temp_2 1.3C

DUT: BlackBerry Smartphone; Type: Sample ; Serial: 295EC578

Communication System: WCDMA FDD V; Frequency: 836.4 MHz

Medium parameters used (interpolated): $f = 836.4$ MHz; $\sigma = 0.978$ mho/m; $\epsilon_r = 55.036$; $\rho = 1000$ kg/m³

Phantom section: Flat Section

Measurement Standard: DASYS (IEEE/IEC/ANSI C63.19-2007)

DASY Configuration:

- Probe: ES3DV3 - SN3225; ConvF(6.07, 6.07, 6.07); Calibrated: 1/11/2012
- Sensor-Surface: 3mm (Mechanical Surface Detection), $z = 2.0, 32.0$
- Electronics: DAE3 Sn472; Calibrated: 3/7/2011
- Phantom: SAM 2; Type: SAM 4.0; Serial: 1080
- DASYS 52.8.0(692); SEMCAD X 14.6.4(4989)

Configuration/Touch position -/Area Scan (31x81x1): Measurement grid:
dx=15mm, dy=15mm

[Info: Interpolated medium parameters used for SAR evaluation.](#)

Maximum value of SAR (interpolated) = 0.091 mW/g

Configuration/Touch position -/Zoom Scan (5x5x7) (6x6x7)/Cube 0:

Measurement grid: dx=7.5mm, dy=7.5mm, dz=5mm

Reference Value = 8.506 V/m; Power Drift = 0.06 dB

Peak SAR (extrapolated) = 0.1460

SAR(1 g) = 0.072 mW/g; SAR(10 g) = 0.044 mW/g

[Info: Interpolated medium parameters used for SAR evaluation.](#)

Maximum value of SAR (measured) = 0.088 mW/g

Author Data
Andrew Becker

Dates of Test
February 06 – March 6 , 2012

Test Report No
RTS-5992-1203-12

FCC ID:
L6AREV70UW

IC ID
2503A-REV70UW

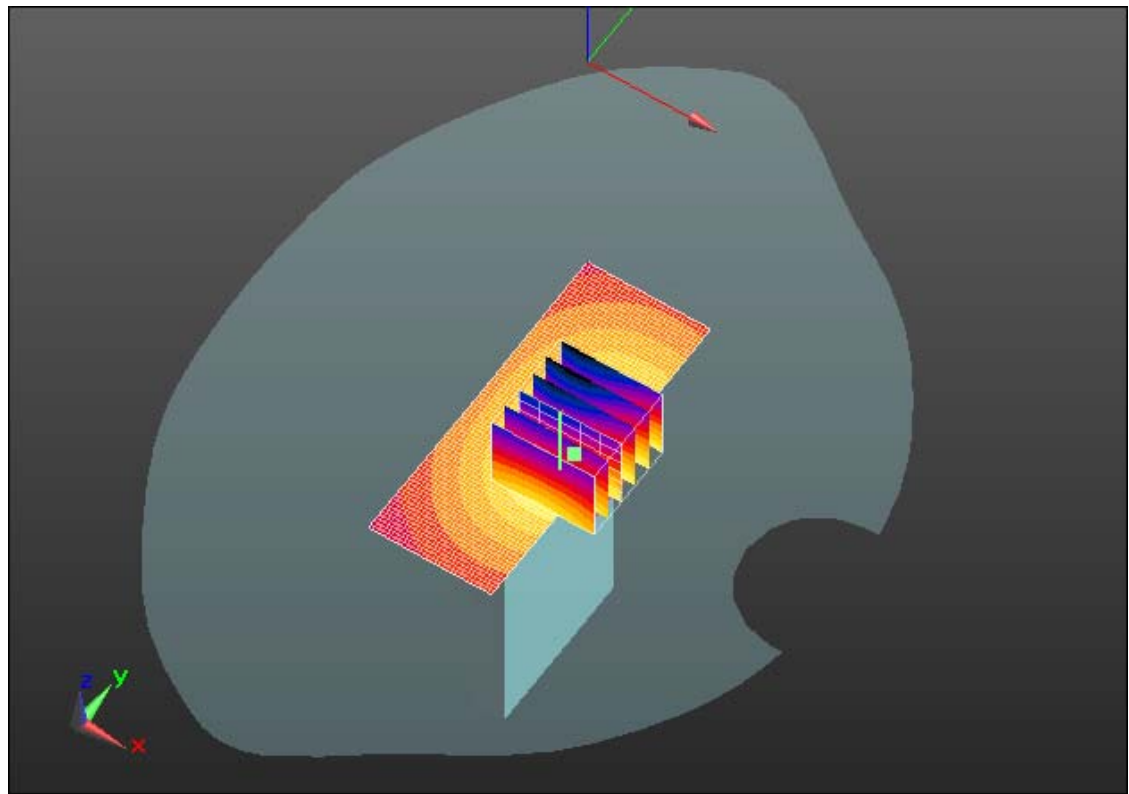
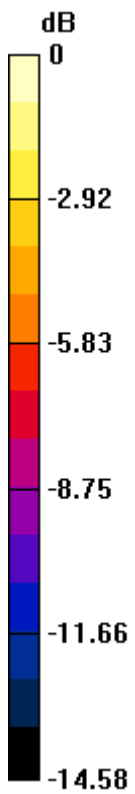

0 dB = 0.090mW/g = -20.92 dB mW/g

	Document Appendix C2 for the BlackBerry® Smartphone Model REV71UW SAR Report			Page 22(64)
	Author Data Andrew Becker	Dates of Test February 06 – March 6 , 2012	Test Report No RTS-5992-1203-12	FCC ID: L6AREV70UW

Date/Time: 2/28/2012 8:05:56 PM

Test Laboratory: RIM Testing Services

MHS_Back_GPRS1900_mid_chan_amb_temp_22.8C_liq_temp_20.0C

DUT: BlackBerry Smartphone; Type: Sample ; Serial: 295EC578

Communication System: GPRS 1900; Frequency: 1880 MHz

Medium parameters used: $f = 1880$ MHz; $\sigma = 1.563$ mho/m; $\epsilon_r = 52.857$; $\rho = 1000$ kg/m³

Phantom section: Flat Section

Measurement Standard: DASYS (IEEE/IEC/ANSI C63.19-2007)

DASY Configuration:

- Probe: ES3DV3 - SN3225; ConvF(4.92, 4.92, 4.92); Calibrated: 1/11/2012
- Sensor-Surface: 3mm (Mechanical Surface Detection), $z = 2.0, 32.0$
- Electronics: DAE3 Sn473; Calibrated: 1/13/2012
- Phantom: SAM 2; Type: SAM 4.0; Serial: 1080
- DASYS2 52.8.0(692); SEMCAD X 14.6.4(4989)

Configuration/Touch position -/Area Scan (61x91x1): Measurement grid:

$dx=15$ mm, $dy=15$ mm

Maximum value of SAR (interpolated) = 0.876 mW/g

Configuration/Touch position -/Zoom Scan (5x5x7) (6x6x7)/Cube 0:

Measurement grid: $dx=7.5$ mm, $dy=7.5$ mm, $dz=5$ mm

Reference Value = 9.059 V/m; Power Drift = -0.11 dB

Peak SAR (extrapolated) = 1.1440

SAR(1 g) = 0.689 mW/g; SAR(10 g) = 0.410 mW/g

Maximum value of SAR (measured) = 0.827 mW/g

Author Data
Andrew Becker

Dates of Test
February 06 – March 6 , 2012

Test Report No
RTS-5992-1203-12

FCC ID:
L6AREV70UW

IC ID
2503A-REV70UW

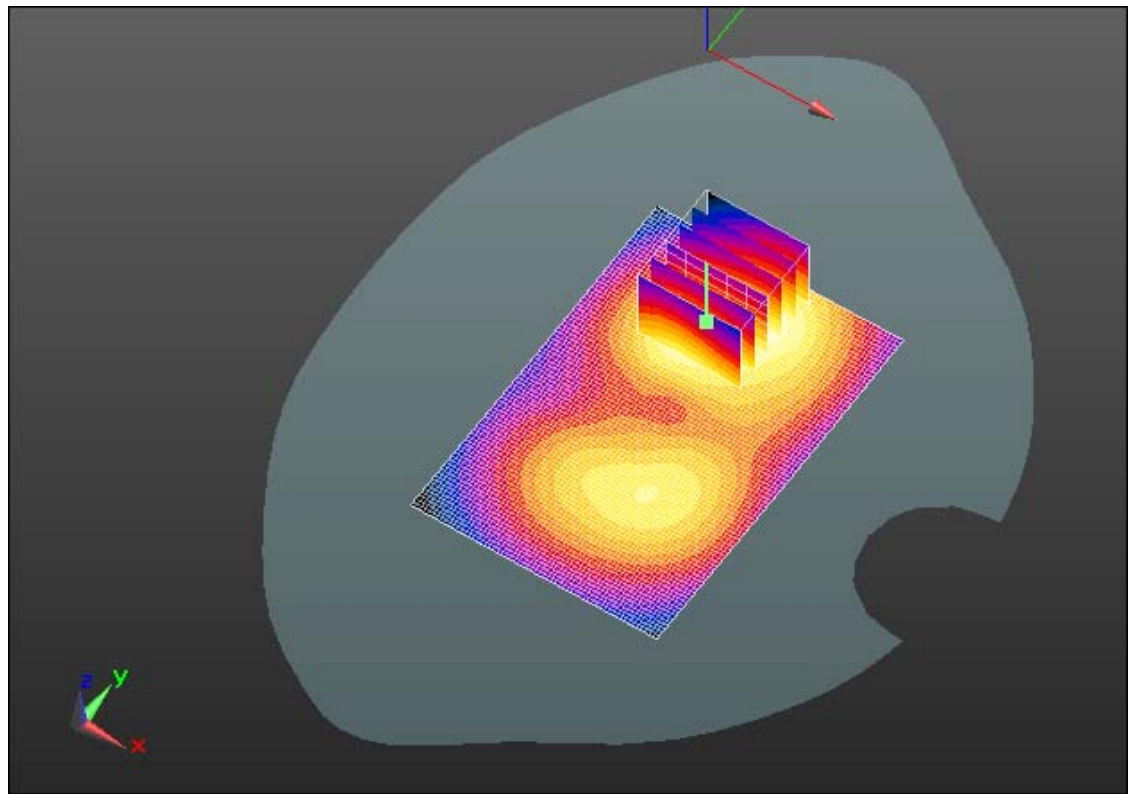
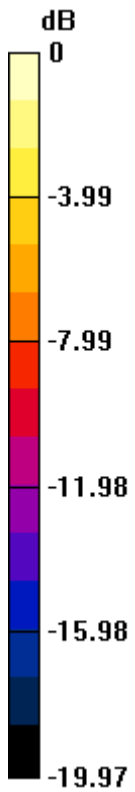

0 dB = 0.830mW/g = -1.62 dB mW/g

	Document Appendix C2 for the BlackBerry® Smartphone Model REV71UW SAR Report			Page 24(64)
	Author Data Andrew Becker	Dates of Test February 06 – March 6 , 2012	Test Report No RTS-5992-1203-12	FCC ID: L6AREV70UW

Date/Time: 2/28/2012 8:30:29 PM

Test Laboratory: RIM Testing Services

MHS_Front_GPRS1900_mid_chan_amb_temp_22.8C_liq_temp_20.0C

DUT: BlackBerry Smartphone; Type: Sample ; Serial: 295EC578

Communication System: GPRS 1900; Frequency: 1880 MHz

Medium parameters used: $f = 1880$ MHz; $\sigma = 1.563$ mho/m; $\epsilon_r = 52.857$; $\rho = 1000$ kg/m³

Phantom section: Flat Section

Measurement Standard: DASYS (IEEE/IEC/ANSI C63.19-2007)

DASY Configuration:

- Probe: ES3DV3 - SN3225; ConvF(4.92, 4.92, 4.92); Calibrated: 1/11/2012
- Sensor-Surface: 3mm (Mechanical Surface Detection), $z = 2.0, 32.0$
- Electronics: DAE3 Sn473; Calibrated: 1/13/2012
- Phantom: SAM 2; Type: SAM 4.0; Serial: 1080
- DASYS2 52.8.0(692); SEMCAD X 14.6.4(4989)

Configuration/Touch position -/Area Scan (61x91x1): Measurement grid:

$dx=15$ mm, $dy=15$ mm

Maximum value of SAR (interpolated) = 0.670 mW/g

Configuration/Touch position -/Zoom Scan (5x5x7) (5x5x7)/Cube 0:

Measurement grid: $dx=7.5$ mm, $dy=7.5$ mm, $dz=5$ mm

Reference Value = 11.490 V/m; Power Drift = 0.01 dB

Peak SAR (extrapolated) = 0.8280

SAR(1 g) = 0.529 mW/g; SAR(10 g) = 0.322 mW/g

Maximum value of SAR (measured) = 0.622 mW/g

Author Data
Andrew Becker

Dates of Test
February 06 – March 6 , 2012

Test Report No
RTS-5992-1203-12

FCC ID:
L6AREV70UW

IC ID
2503A-REV70UW

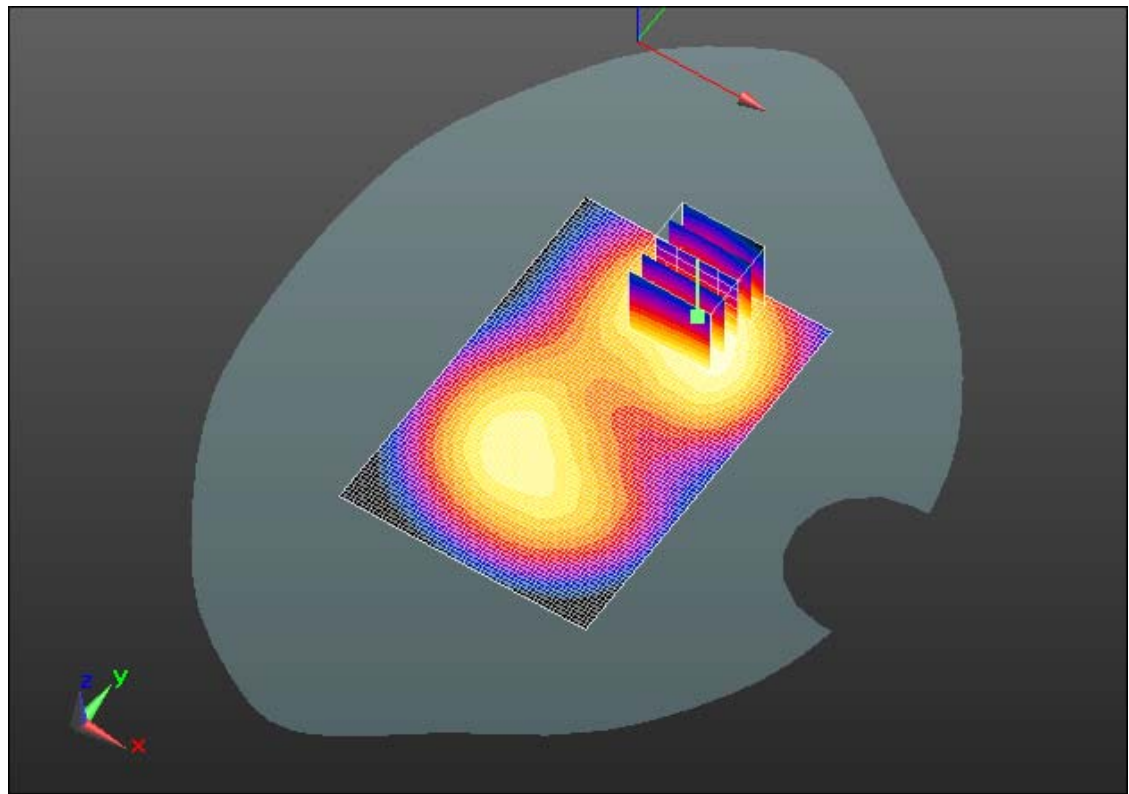
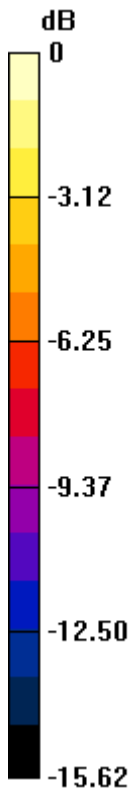

0 dB = 0.620mW/g = -4.15 dB mW/g

	Document Appendix C2 for the BlackBerry® Smartphone Model REV71UW SAR Report			Page 26(64)
	Author Data Andrew Becker	Dates of Test February 06 – March 6 , 2012	Test Report No RTS-5992-1203-12	FCC ID: L6AREV70UW

Date/Time: 2/28/2012 9:10:29 PM

Test Laboratory: RIM Testing Services

MHS_Right_GPRS1900_mid_chan_amb_temp_22.7C_liq_temp_19.9C

DUT: BlackBerry Smartphone; Type: Sample ; Serial: 295EC578

Communication System: GPRS 1900; Frequency: 1880 MHz

Medium parameters used: $f = 1880$ MHz; $\sigma = 1.563$ mho/m; $\epsilon_r = 52.857$; $\rho = 1000$ kg/m³

Phantom section: Flat Section

Measurement Standard: DASYS (IEEE/IEC/ANSI C63.19-2007)

DASY Configuration:

- Probe: ES3DV3 - SN3225; ConvF(4.92, 4.92, 4.92); Calibrated: 1/11/2012
- Sensor-Surface: 3mm (Mechanical Surface Detection), $z = 2.0, 32.0$
- Electronics: DAE3 Sn473; Calibrated: 1/13/2012
- Phantom: SAM 2; Type: SAM 4.0; Serial: 1080
- DASYS2 52.8.0(692); SEMCAD X 14.6.4(4989)

Configuration/Touch position -/Area Scan (31x101x1): Measurement grid:

$dx=15$ mm, $dy=15$ mm

Maximum value of SAR (interpolated) = 0.275 mW/g

Configuration/Touch position -/Zoom Scan (5x5x7) (5x5x7)/Cube 0:

Measurement grid: $dx=7.5$ mm, $dy=7.5$ mm, $dz=5$ mm

Reference Value = 10.865 V/m; Power Drift = 0.10 dB

Peak SAR (extrapolated) = 0.3640

SAR(1 g) = 0.228 mW/g; SAR(10 g) = 0.136 mW/g

Maximum value of SAR (measured) = 0.275 mW/g

	Document Appendix C2 for the BlackBerry® Smartphone Model REV71UW SAR Report			Page 27(64)
	Author Data Andrew Becker	Dates of Test February 06 – March 6 , 2012	Test Report No RTS-5992-1203-12	FCC ID: L6AREV70UW

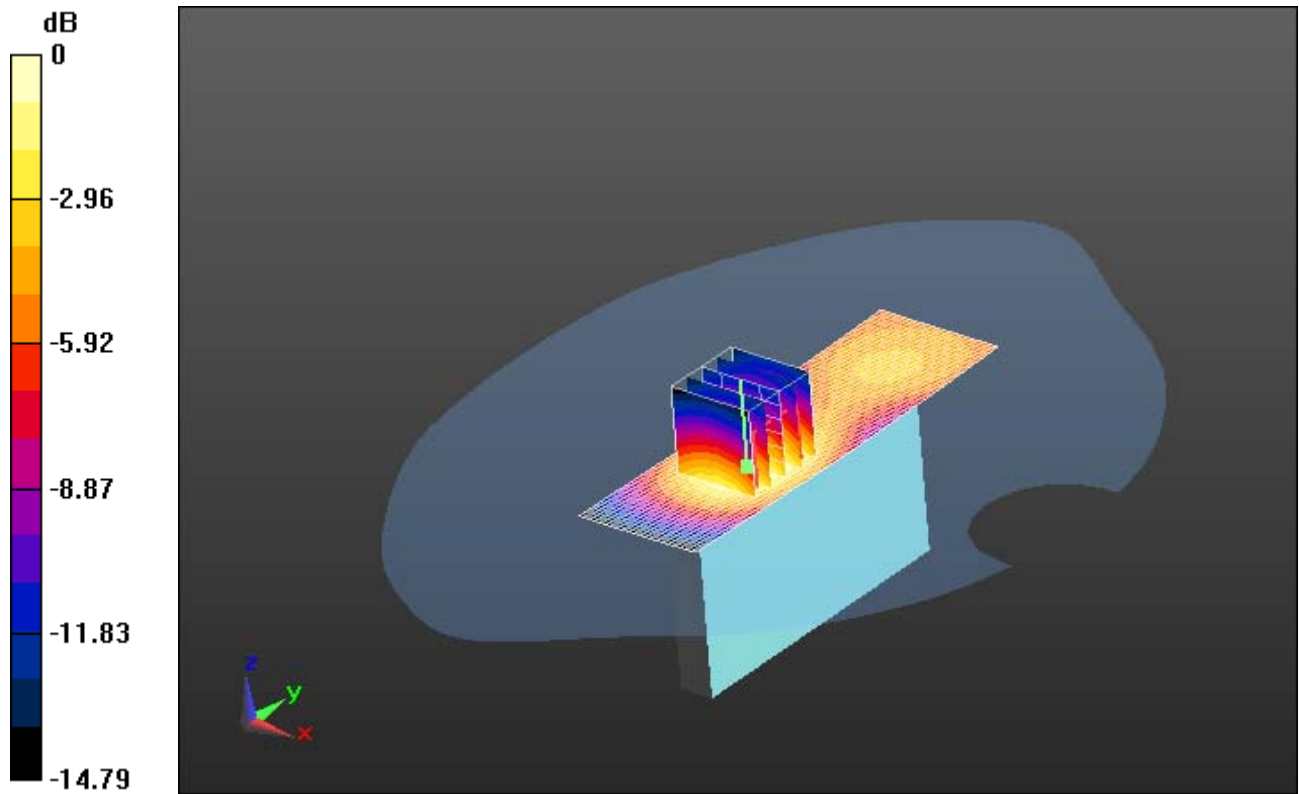

0 dB = 0.270mW/g = -11.37 dB mW/g

	Document Appendix C2 for the BlackBerry® Smartphone Model REV71UW SAR Report			Page 28(64)
	Author Data Andrew Becker	Dates of Test February 06 – March 6 , 2012	Test Report No RTS-5992-1203-12	FCC ID: L6AREV70UW

Date/Time: 2/28/2012 9:37:46 PM

Test Laboratory: RIM Testing Services

MHS_Left_GPRS1900_mid_chan_amb_temp_22.7C_liq_temp_19.9C

DUT: BlackBerry Smartphone; Type: Sample ; Serial: 295EC578

Communication System: GPRS 1900; Frequency: 1880 MHz

Medium parameters used: $f = 1880$ MHz; $\sigma = 1.563$ mho/m; $\epsilon_r = 52.857$; $\rho = 1000$ kg/m³

Phantom section: Flat Section

Measurement Standard: DASYS (IEEE/IEC/ANSI C63.19-2007)

DASY Configuration:

- Probe: ES3DV3 - SN3225; ConvF(4.92, 4.92, 4.92); Calibrated: 1/11/2012
- Sensor-Surface: 3mm (Mechanical Surface Detection), $z = 2.0, 32.0$
- Electronics: DAE3 Sn473; Calibrated: 1/13/2012
- Phantom: SAM 2; Type: SAM 4.0; Serial: 1080
- DASYS2 52.8.0(692); SEMCAD X 14.6.4(4989)

Configuration/Touch position -/Area Scan (31x101x1): Measurement grid:

$dx=15$ mm, $dy=15$ mm

Maximum value of SAR (interpolated) = 0.220 mW/g

Configuration/Touch position -/Zoom Scan (5x5x7) (5x5x7)/Cube 0:

Measurement grid: $dx=7.5$ mm, $dy=7.5$ mm, $dz=5$ mm

Reference Value = 8.665 V/m; Power Drift = -0.14 dB

Peak SAR (extrapolated) = 0.2870

SAR(1 g) = 0.174 mW/g; SAR(10 g) = 0.101 mW/g

Maximum value of SAR (measured) = 0.210 mW/g

Author Data
Andrew Becker

Dates of Test
February 06 – March 6 , 2012

Test Report No
RTS-5992-1203-12

FCC ID:
L6AREV70UW

IC ID
2503A-REV70UW

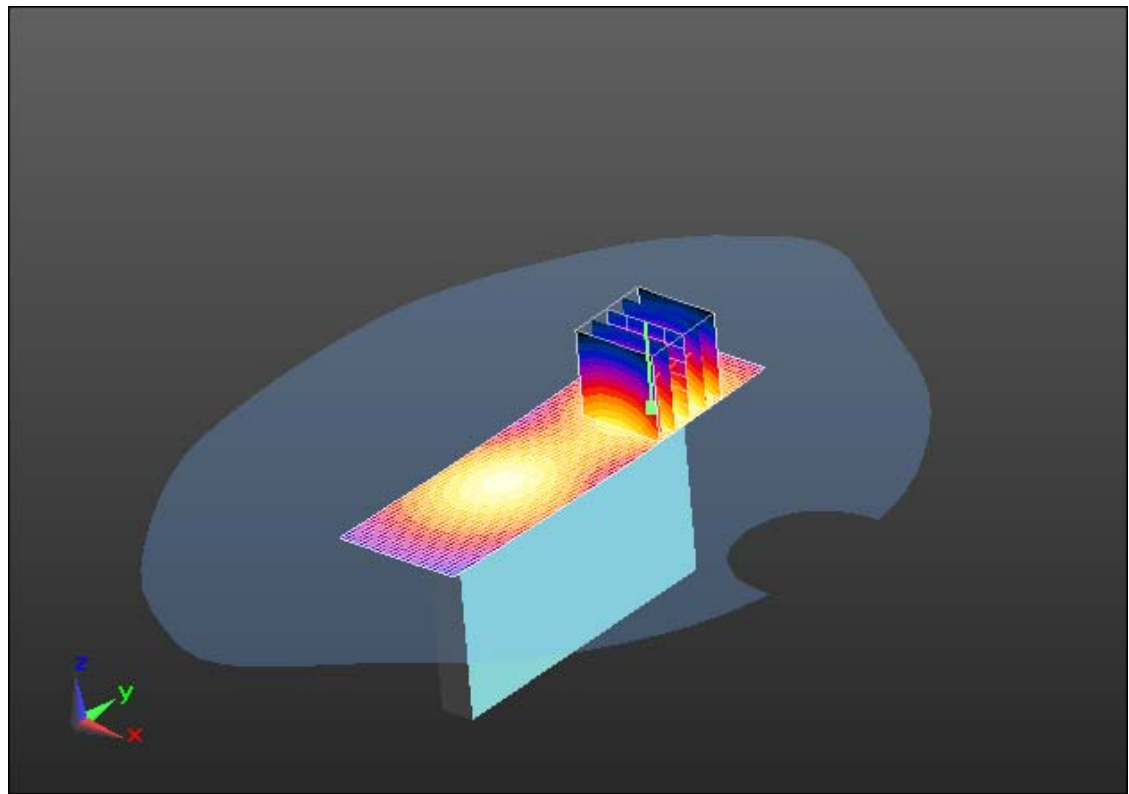
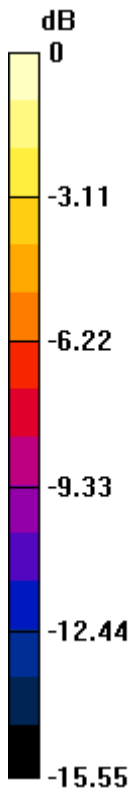

0 dB = 0.210mW/g = -13.56 dB mW/g

	Document Appendix C2 for the BlackBerry® Smartphone Model REV71UW SAR Report			Page 30(64)
	Author Data Andrew Becker	Dates of Test February 06 – March 6 , 2012	Test Report No RTS-5992-1203-12	FCC ID: L6AREV70UW

Date/Time: 2/28/2012 10:16:13 PM

Test Laboratory: RIM Testing Services

MHS_Bottom_GPRS1900_low_chan_amb_temp_22.7C_liq_temp_20.0C

DUT: BlackBerry Smartphone; Type: Sample ; Serial: 295EC578

Communication System: GPRS 1900; Frequency: 1850.2 MHz

Medium parameters used (interpolated): $f = 1850.2$ MHz; $\sigma = 1.534$ mho/m; $\epsilon_r = 52.968$;
 $\rho = 1000$ kg/m³

Phantom section: Flat Section

Measurement Standard: DASYS (IEEE/IEC/ANSI C63.19-2007)

DASY Configuration:

- Probe: ES3DV3 - SN3225; ConvF(4.92, 4.92, 4.92); Calibrated: 1/11/2012
- Sensor-Surface: 3mm (Mechanical Surface Detection), $z = 2.0, 32.0$
- Electronics: DAE3 Sn473; Calibrated: 1/13/2012
- Phantom: SAM 2; Type: SAM 4.0; Serial: 1080
- DASYS 52.8.0(692); SEMCAD X 14.6.4(4989)

Configuration/Touch position -/Area Scan (31x81x1): Measurement grid:
 $dx=15$ mm, $dy=15$ mm

[Info: Interpolated medium parameters used for SAR evaluation.](#)

Maximum value of SAR (interpolated) = 1.009 mW/g

Configuration/Touch position -/Zoom Scan (5x5x7) (5x5x7)/Cube 0:

Measurement grid: $dx=7.5$ mm, $dy=7.5$ mm, $dz=5$ mm

Reference Value = 26.625 V/m; Power Drift = 0.0039 dB

Peak SAR (extrapolated) = 1.3680

SAR(1 g) = 0.823 mW/g; SAR(10 g) = 0.448 mW/g

[Info: Interpolated medium parameters used for SAR evaluation.](#)

Maximum value of SAR (measured) = 1.016 mW/g

Author Data
Andrew Becker

Dates of Test
February 06 – March 6 , 2012

Test Report No
RTS-5992-1203-12

FCC ID:
L6AREV70UW

IC ID
2503A-REV70UW

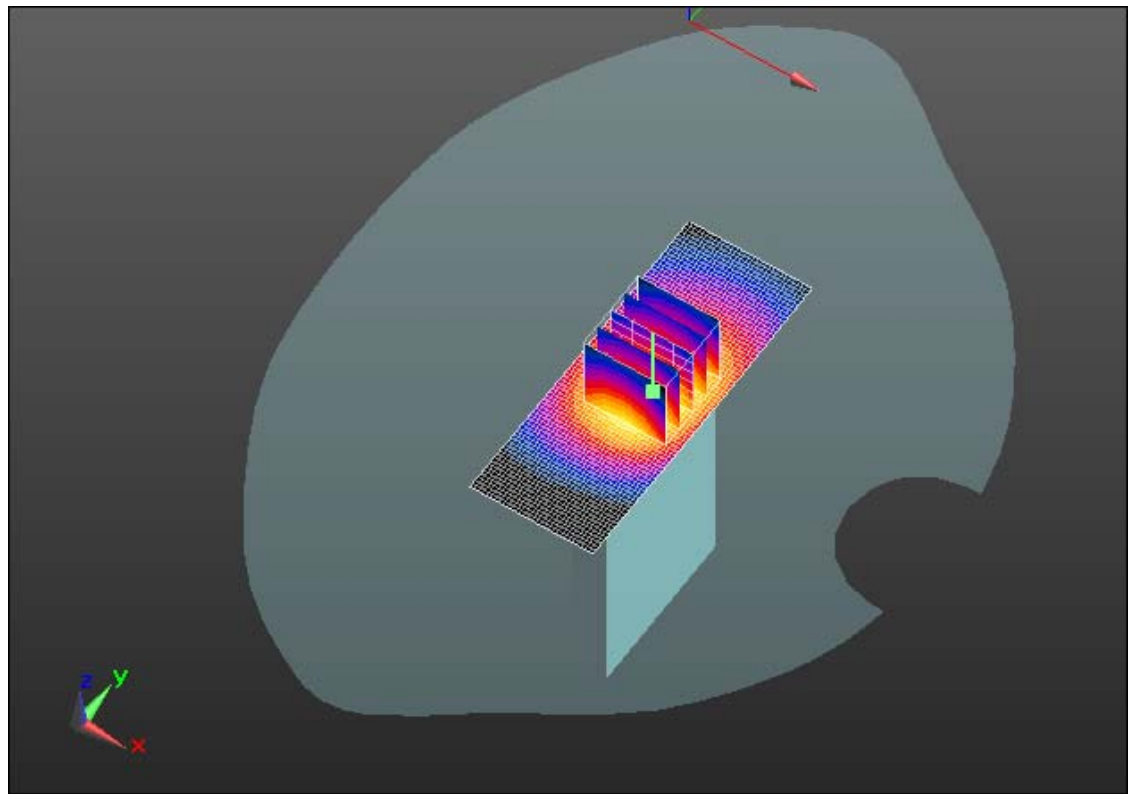
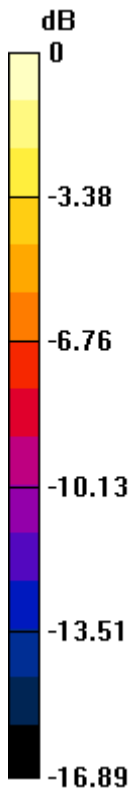

0 dB = 1.020mW/g = 0.17 dB mW/g

	Document Appendix C2 for the BlackBerry® Smartphone Model REV71UW SAR Report			Page 32(64)
	Author Data Andrew Becker	Dates of Test February 06 – March 6 , 2012	Test Report No RTS-5992-1203-12	FCC ID: L6AREV70UW

Date/Time: 2/28/2012 10:00:44 PM

Test Laboratory: RIM Testing Services

MHS_Bottom_GPRS1900_mid_chan_amb_temp_22.8C_liq_temp_20.0C

DUT: BlackBerry Smartphone; Type: Sample ; Serial: 295EC578

Communication System: GPRS 1900; Frequency: 1880 MHz

Medium parameters used: $f = 1880$ MHz; $\sigma = 1.563$ mho/m; $\epsilon_r = 52.857$; $\rho = 1000$ kg/m³

Phantom section: Flat Section

Measurement Standard: DASYS (IEEE/IEC/ANSI C63.19-2007)

DASY Configuration:

- Probe: ES3DV3 - SN3225; ConvF(4.92, 4.92, 4.92); Calibrated: 1/11/2012
- Sensor-Surface: 3mm (Mechanical Surface Detection), $z = 2.0, 32.0$
- Electronics: DAE3 Sn473; Calibrated: 1/13/2012
- Phantom: SAM 2; Type: SAM 4.0; Serial: 1080
- DASYS2 52.8.0(692); SEMCAD X 14.6.4(4989)

Configuration/Touch position -/Area Scan (31x81x1): Measurement grid:

$dx=15$ mm, $dy=15$ mm

Maximum value of SAR (interpolated) = 1.187 mW/g

Configuration/Touch position -/Zoom Scan (5x5x7) (5x5x7)/Cube 0:

Measurement grid: $dx=7.5$ mm, $dy=7.5$ mm, $dz=5$ mm

Reference Value = 28.617 V/m; Power Drift = -0.0097 dB

Peak SAR (extrapolated) = 1.6150

SAR(1 g) = 0.965 mW/g; SAR(10 g) = 0.522 mW/g

Maximum value of SAR (measured) = 1.194 mW/g

Author Data
Andrew Becker

Dates of Test
February 06 – March 6 , 2012

Test Report No
RTS-5992-1203-12

FCC ID:
L6AREV70UW

IC ID
2503A-REV70UW

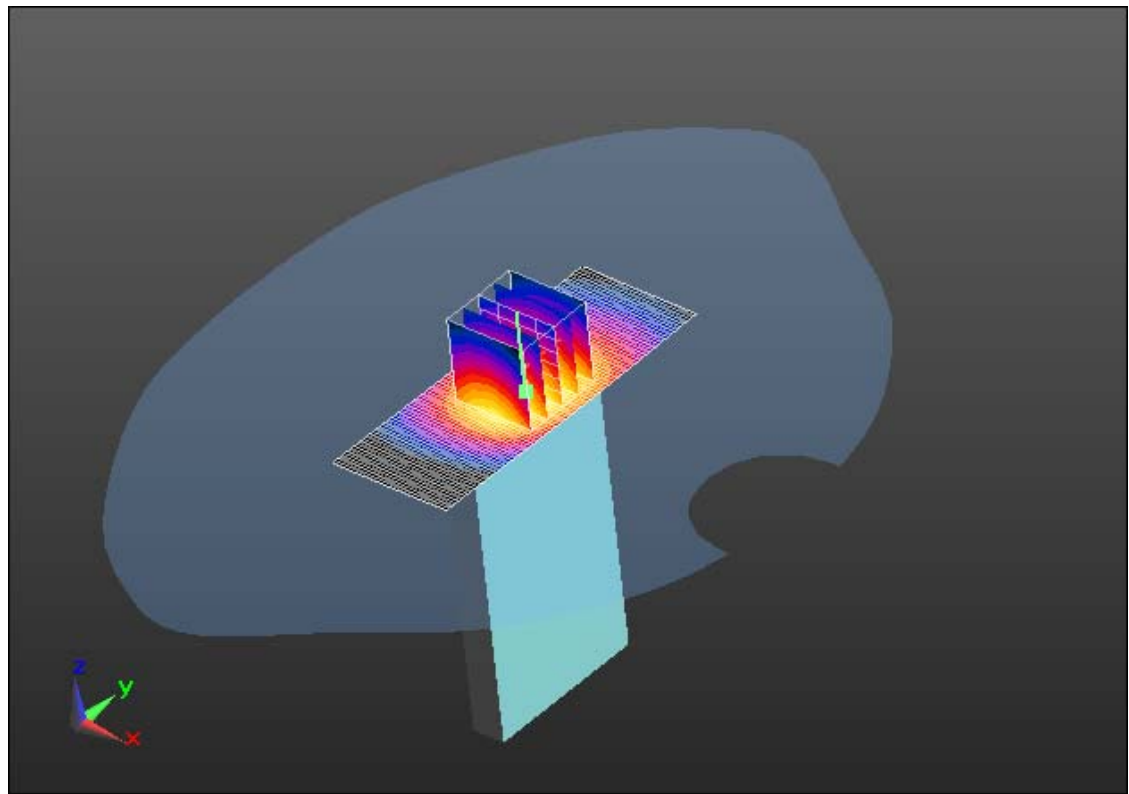
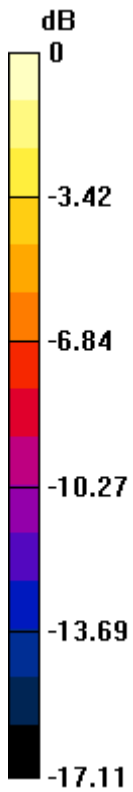

0 dB = 1.190mW/g = 1.51 dB mW/g

	Document Appendix C2 for the BlackBerry® Smartphone Model REV71UW SAR Report			Page 34(64)
	Author Data Andrew Becker	Dates of Test February 06 – March 6 , 2012	Test Report No RTS-5992-1203-12	FCC ID: L6AREV70UW

Date/Time: 2/28/2012 10:29:11 PM

Test Laboratory: RIM Testing Services

MHS_Bottom_GPRS1900_high_chan_amb_temp_22.7C_liq_temp_20.0 C

DUT: BlackBerry Smartphone; Type: Sample ; Serial: 295EC578

Communication System: GPRS 1900; Frequency: 1909.8 MHz

Medium parameters used: $f = 1910$ MHz; $\sigma = 1.596$ mho/m; $\epsilon_r = 52.763$; $\rho = 1000$ kg/m³

Phantom section: Flat Section

Measurement Standard: DASYS (IEEE/IEC/ANSI C63.19-2007)

DASY Configuration:

- Probe: ES3DV3 - SN3225; ConvF(4.92, 4.92, 4.92); Calibrated: 1/11/2012
- Sensor-Surface: 3mm (Mechanical Surface Detection), $z = 2.0, 32.0$
- Electronics: DAE3 Sn473; Calibrated: 1/13/2012
- Phantom: SAM 2; Type: SAM 4.0; Serial: 1080
- DASYS2 52.8.0(692); SEMCAD X 14.6.4(4989)

Configuration/Touch position -/Area Scan (31x81x1): Measurement grid:
 $dx=15$ mm, $dy=15$ mm

Maximum value of SAR (interpolated) = 1.344 mW/g

Configuration/Touch position -/Zoom Scan (5x5x7) (5x5x7)/Cube 0:

Measurement grid: $dx=7.5$ mm, $dy=7.5$ mm, $dz=5$ mm

Reference Value = 30.119 V/m; Power Drift = -0.04 dB

Peak SAR (extrapolated) = 1.8460

SAR(1 g) = 1.08 mW/g; SAR(10 g) = 0.586 mW/g

Maximum value of SAR (measured) = 1.355 mW/g

Author Data
Andrew Becker

Dates of Test
February 06 – March 6 , 2012

Test Report No
RTS-5992-1203-12

FCC ID:
L6AREV70UW

IC ID
2503A-REV70UW

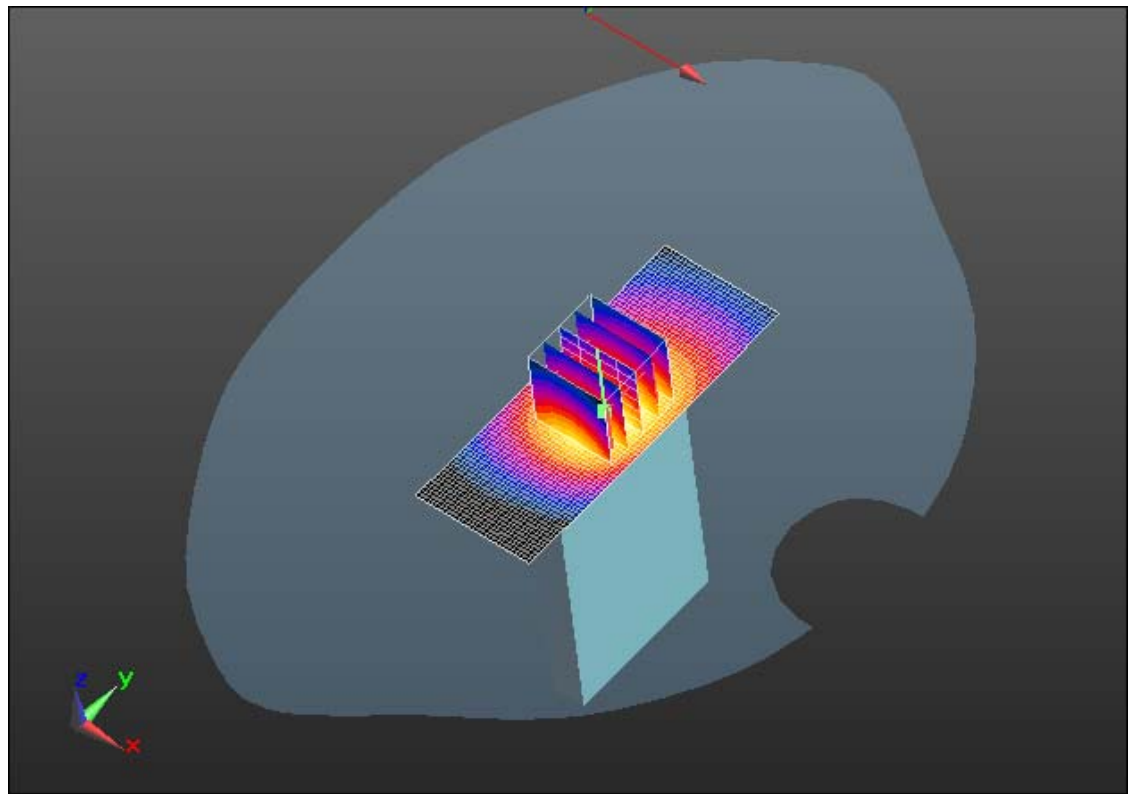
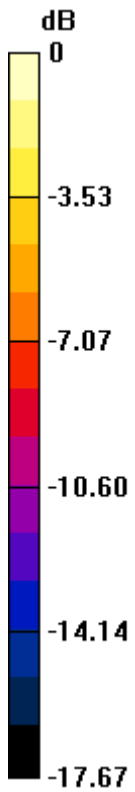

0 dB = 1.350mW/g = 2.61 dB mW/g

	Document Appendix C2 for the BlackBerry® Smartphone Model REV71UW SAR Report			Page 36(64)
	Author Data Andrew Becker	Dates of Test February 06 – March 6 , 2012	Test Report No RTS-5992-1203-12	FCC ID: L6AREV70UW

Date/Time: 2/7/2012 6:33:22 PM

Test Laboratory: RIM Testing Services

MHS_Back_UMTS_band_II_mid_chan_amb_temp_22.8_liq_temp_20.8C

DUT: BlackBerry Smartphone; Type: Sample ; Serial: 295EC578

Communication System: WCDMA FDD II; Frequency: 1880 MHz

Medium parameters used: $f = 1880$ MHz; $\sigma = 1.525$ mho/m; $\epsilon_r = 52.799$; $\rho = 1000$ kg/m³

Phantom section: Flat Section

Measurement Standard: DASYS (IEEE/IEC/ANSI C63.19-2007)

DASY Configuration:

- Probe: ET3DV6 - SN1644; ConvF(4.69, 4.69, 4.69); Calibrated: 11/15/2011
- Sensor-Surface: 4mm (Mechanical Surface Detection), $z = 2.7, 32.7$
- Electronics: DAE3 Sn472; Calibrated: 3/7/2011
- Phantom: SAM 2; Type: SAM 4.0; Serial: 1080
- DASYS2 52.8.0(692); SEMCAD X 14.6.4(4989)

Configuration/Touch position -/Area Scan (61x91x1): Measurement grid:

$dx=15$ mm, $dy=15$ mm

Maximum value of SAR (interpolated) = 0.870 mW/g

Configuration/Touch position -/Zoom Scan (5x5x7) (5x5x7)/Cube 0:

Measurement grid: $dx=7.5$ mm, $dy=7.5$ mm, $dz=5$ mm

Reference Value = 10.927 V/m; Power Drift = 0.06 dB

Peak SAR (extrapolated) = 1.2410

SAR(1 g) = 0.771 mW/g; SAR(10 g) = 0.459 mW/g

Maximum value of SAR (measured) = 0.853 mW/g

Author Data
Andrew Becker

Dates of Test
February 06 – March 6 , 2012

Test Report No
RTS-5992-1203-12

FCC ID:
L6AREV70UW

IC ID
2503A-REV70UW

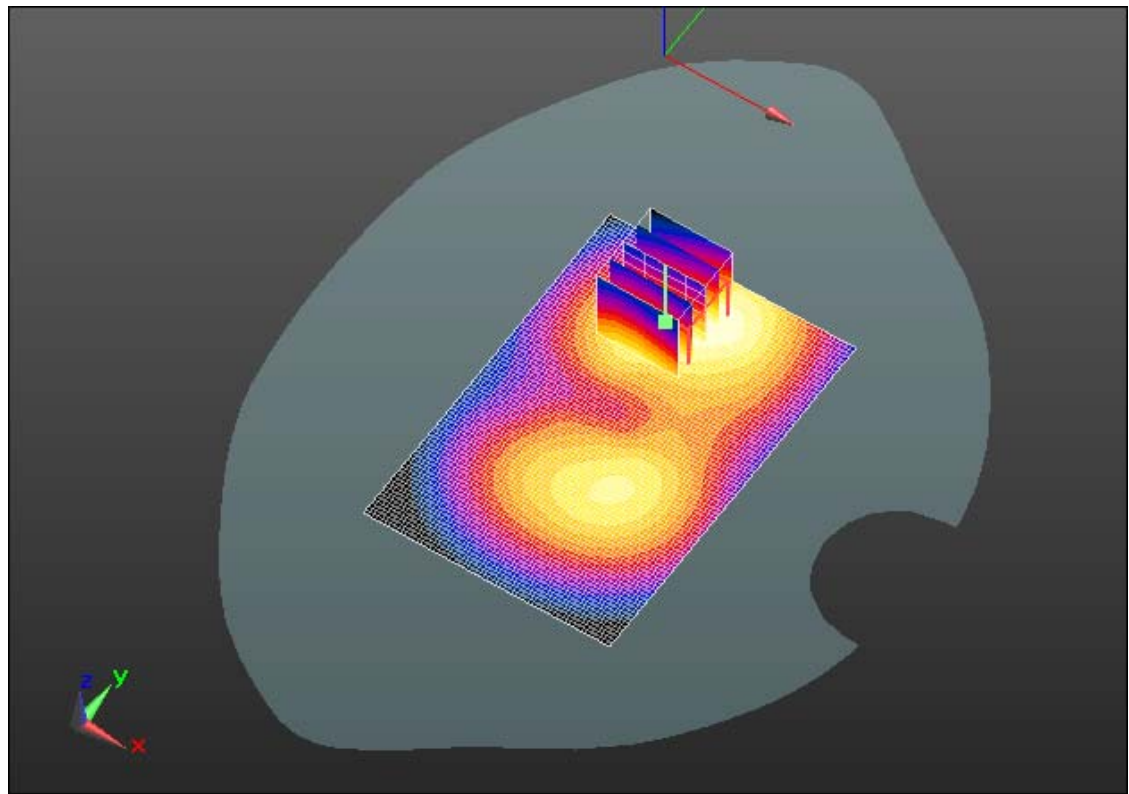
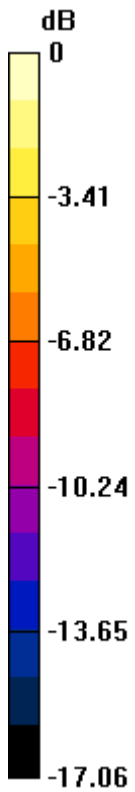

0 dB = 0.850mW/g = -1.41 dB mW/g

	Document Appendix C2 for the BlackBerry® Smartphone Model REV71UW SAR Report			Page 38(64)
	Author Data Andrew Becker	Dates of Test February 06 – March 6 , 2012	Test Report No RTS-5992-1203-12	FCC ID: L6AREV70UW

Date/Time: 2/7/2012 6:56:45 PM

Test Laboratory: RIM Testing Services

MHS_Front_UMTS_band_II_mid_chan_amb_temp_22.8_liq_temp_20.8C

DUT: BlackBerry Smartphone; Type: Sample ; Serial: 295EC578

Communication System: WCDMA FDD II; Frequency: 1880 MHz

Medium parameters used: $f = 1880$ MHz; $\sigma = 1.525$ mho/m; $\epsilon_r = 52.799$; $\rho = 1000$ kg/m³

Phantom section: Flat Section

Measurement Standard: DASYS (IEEE/IEC/ANSI C63.19-2007)

DASY Configuration:

- Probe: ET3DV6 - SN1644; ConvF(4.69, 4.69, 4.69); Calibrated: 11/15/2011
- Sensor-Surface: 4mm (Mechanical Surface Detection), $z = 2.7, 32.7$
- Electronics: DAE3 Sn472; Calibrated: 3/7/2011
- Phantom: SAM 2; Type: SAM 4.0; Serial: 1080
- DASYS2 52.8.0(692); SEMCAD X 14.6.4(4989)

Configuration/Touch position -/Area Scan (61x91x1): Measurement grid:

$dx=15$ mm, $dy=15$ mm

Maximum value of SAR (interpolated) = 0.735 mW/g

Configuration/Touch position -/Zoom Scan (5x5x7) (5x5x7)/Cube 0:

Measurement grid: $dx=7.5$ mm, $dy=7.5$ mm, $dz=5$ mm

Reference Value = 13.225 V/m; Power Drift = 0.0025 dB

Peak SAR (extrapolated) = 1.0320

SAR(1 g) = 0.654 mW/g; SAR(10 g) = 0.402 mW/g

Maximum value of SAR (measured) = 0.692 mW/g

Author Data
Andrew Becker

Dates of Test
February 06 – March 6 , 2012

Test Report No
RTS-5992-1203-12

FCC ID:
L6AREV70UW

IC ID
2503A-REV70UW

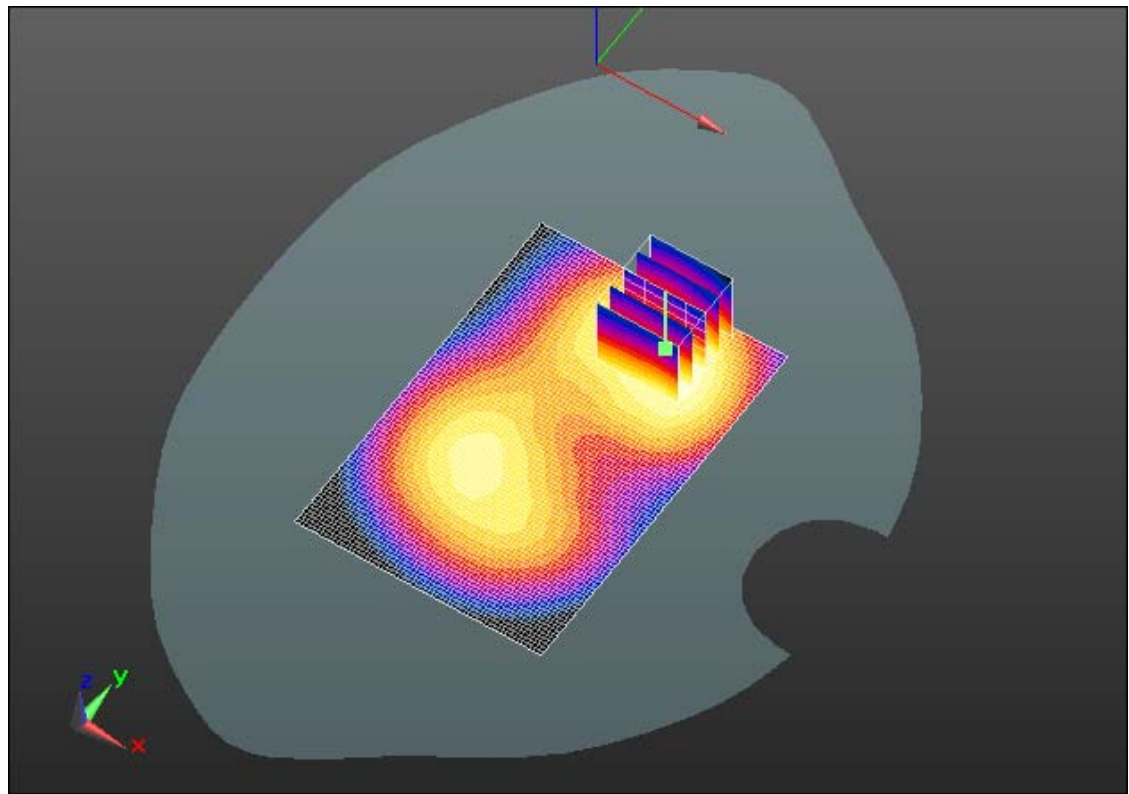
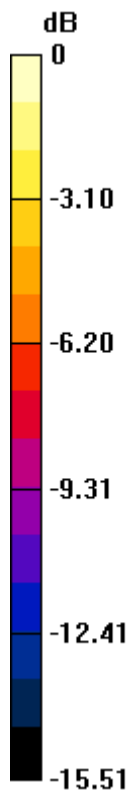

0 dB = 0.690mW/g = -3.22 dB mW/g

	Document Appendix C2 for the BlackBerry® Smartphone Model REV71UW SAR Report			Page 40(64)
	Author Data Andrew Becker	Dates of Test February 06 – March 6 , 2012	Test Report No RTS-5992-1203-12	FCC ID: L6AREV70UW

Date/Time: 2/7/2012 7:24:04 PM

Test Laboratory: RIM Testing Services

MHS_Right_UMTS_band_II_mid_chan_amb_temp_22.8_liq_temp_20.8C

DUT: BlackBerry Smartphone; Type: Sample ; Serial: 295EC578

Communication System: WCDMA FDD II; Frequency: 1880 MHz

Medium parameters used: $f = 1880$ MHz; $\sigma = 1.525$ mho/m; $\epsilon_r = 52.799$; $\rho = 1000$ kg/m³

Phantom section: Flat Section

Measurement Standard: DASYS (IEEE/IEC/ANSI C63.19-2007)

DASY Configuration:

- Probe: ET3DV6 - SN1644; ConvF(4.69, 4.69, 4.69); Calibrated: 11/15/2011
- Sensor-Surface: 4mm (Mechanical Surface Detection), $z = 2.7, 32.7$
- Electronics: DAE3 Sn472; Calibrated: 3/7/2011
- Phantom: SAM 2; Type: SAM 4.0; Serial: 1080
- DASYS2 52.8.0(692); SEMCAD X 14.6.4(4989)

Configuration/Touch position -/Area Scan (31x101x1): Measurement grid:

$dx=15$ mm, $dy=15$ mm

Maximum value of SAR (interpolated) = 0.314 mW/g

Configuration/Touch position -/Zoom Scan (5x5x7) (5x5x7)/Cube 0:

Measurement grid: $dx=7.5$ mm, $dy=7.5$ mm, $dz=5$ mm

Reference Value = 12.177 V/m; Power Drift = 0.02 dB

Peak SAR (extrapolated) = 0.4400

SAR(1 g) = 0.278 mW/g; SAR(10 g) = 0.166 mW/g

Maximum value of SAR (measured) = 0.305 mW/g

	Document Appendix C2 for the BlackBerry® Smartphone Model REV71UW SAR Report			Page 41(64)
	Author Data Andrew Becker	Dates of Test February 06 – March 6 , 2012	Test Report No RTS-5992-1203-12	FCC ID: L6AREV70UW

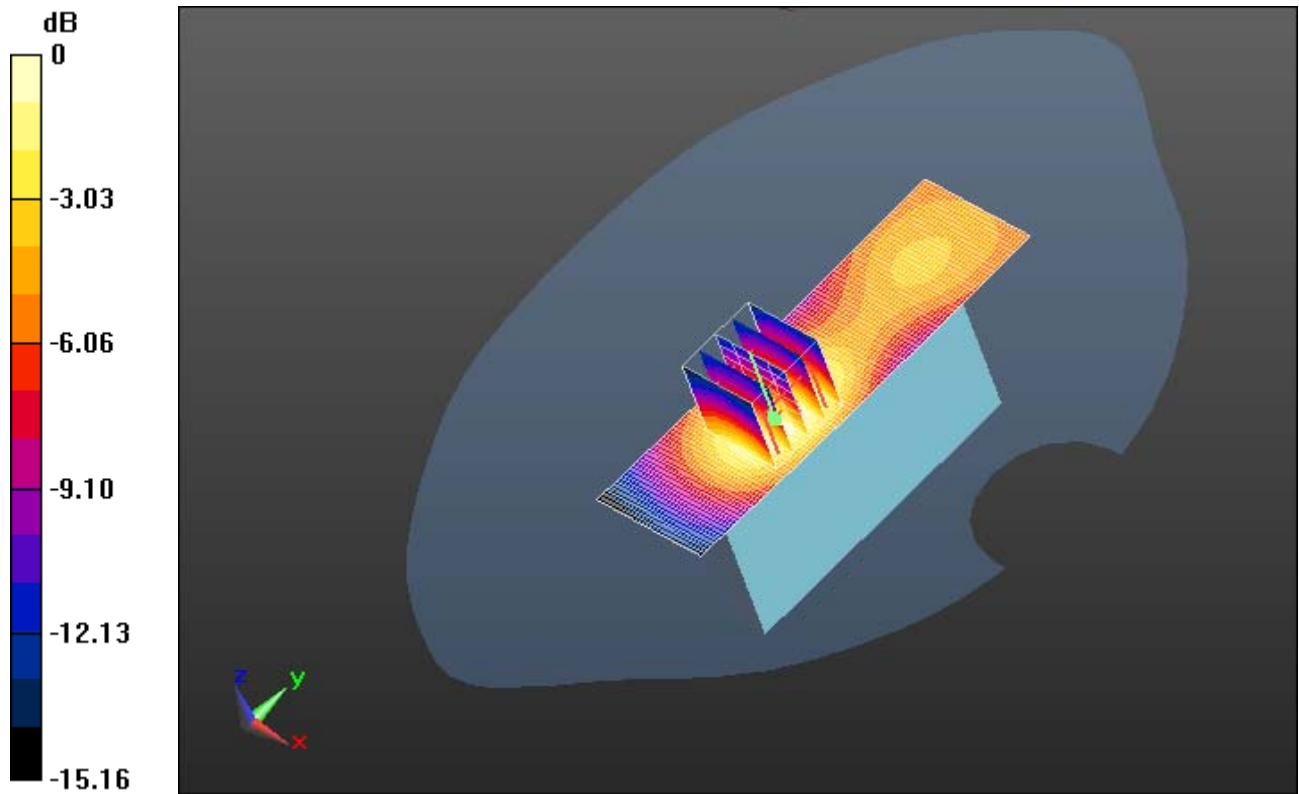

0 dB = 0.300mW/g = -10.46 dB mW/g

	Document Appendix C2 for the BlackBerry® Smartphone Model REV71UW SAR Report			Page 42(64)
	Author Data Andrew Becker	Dates of Test February 06 – March 6 , 2012	Test Report No RTS-5992-1203-12	FCC ID: L6AREV70UW

Date/Time: 2/7/2012 7:43:23 PM

Test Laboratory: RIM Testing Services

MHS_Left_UMTS_band_II_mid_chan_amb_temp_22.8_liq_temp_20.8C

DUT: BlackBerry Smartphone; Type: Sample ; Serial: 295EC578

Communication System: WCDMA FDD II; Frequency: 1880 MHz

Medium parameters used: $f = 1880$ MHz; $\sigma = 1.525$ mho/m; $\epsilon_r = 52.799$; $\rho = 1000$ kg/m³

Phantom section: Flat Section

Measurement Standard: DASYS (IEEE/IEC/ANSI C63.19-2007)

DASY Configuration:

- Probe: ET3DV6 - SN1644; ConvF(4.69, 4.69, 4.69); Calibrated: 11/15/2011
- Sensor-Surface: 4mm (Mechanical Surface Detection), $z = 2.7, 32.7$
- Electronics: DAE3 Sn472; Calibrated: 3/7/2011
- Phantom: SAM 2; Type: SAM 4.0; Serial: 1080
- DASYS2 52.8.0(692); SEMCAD X 14.6.4(4989)

Configuration/Touch position -/Area Scan (31x101x1): Measurement grid:

$dx=15$ mm, $dy=15$ mm

Maximum value of SAR (interpolated) = 0.241 mW/g

Configuration/Touch position -/Zoom Scan (5x5x7) (5x5x7)/Cube 0:

Measurement grid: $dx=7.5$ mm, $dy=7.5$ mm, $dz=5$ mm

Reference Value = 9.882 V/m; Power Drift = 0.03 dB

Peak SAR (extrapolated) = 0.3390

SAR(1 g) = 0.214 mW/g; SAR(10 g) = 0.126 mW/g

Maximum value of SAR (measured) = 0.237 mW/g

	Document Appendix C2 for the BlackBerry® Smartphone Model REV71UW SAR Report			Page 43(64)
	Author Data Andrew Becker	Dates of Test February 06 – March 6 , 2012	Test Report No RTS-5992-1203-12	FCC ID: L6AREV70UW

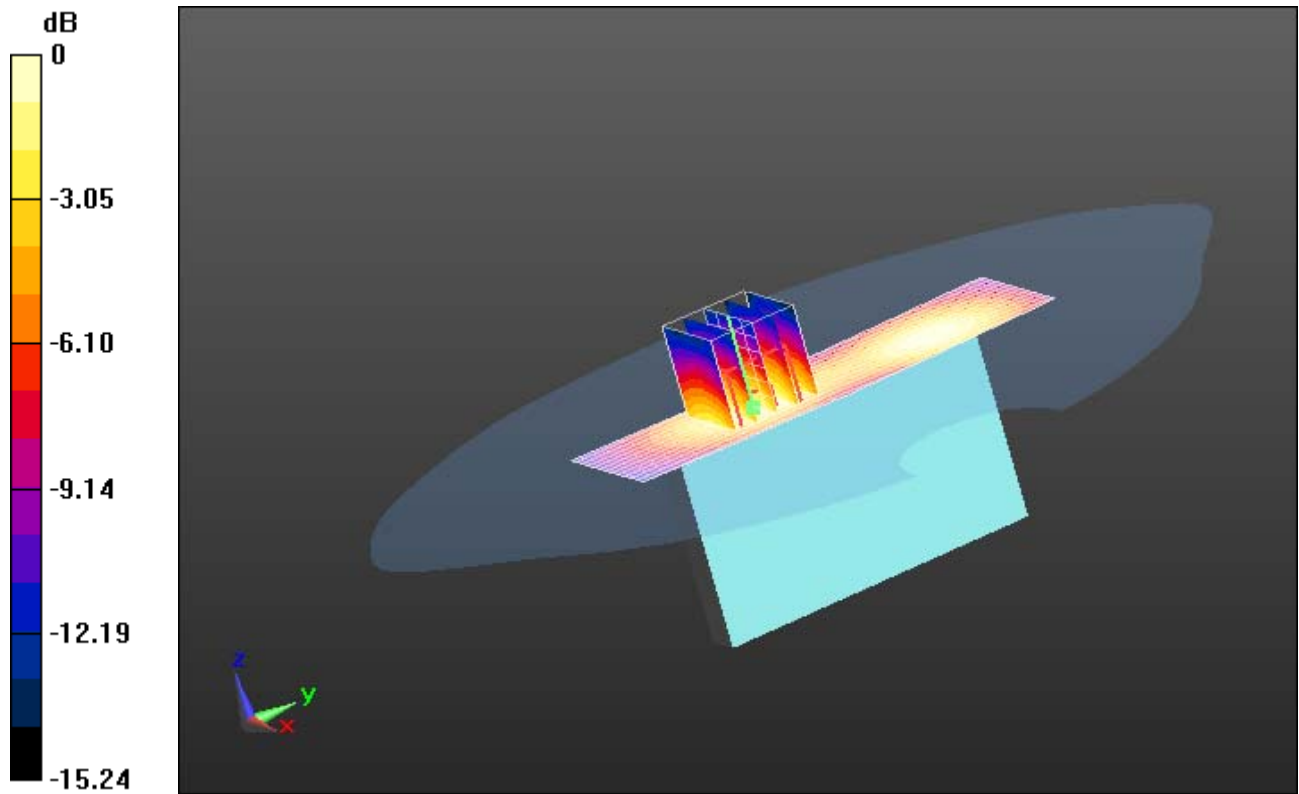

0 dB = 0.240mW/g = -12.40 dB mW/g

	Document Appendix C2 for the BlackBerry® Smartphone Model REV71UW SAR Report			Page 44(64)
	Author Data Andrew Becker	Dates of Test February 06 – March 6 , 2012	Test Report No RTS-5992-1203-12	FCC ID: L6AREV70UW

Date/Time: 2/7/2012 8:21:35 PM

Test Laboratory: RIM Testing Services

MHS_Bottom_UMTS_band_II_low_chan_amb_temp_22.8_liq_temp_20.8 C

DUT: BlackBerry Smartphone; Type: Sample ; Serial: 295EC578

Communication System: WCDMA FDD II; Frequency: 1852.4 MHz

Medium parameters used (interpolated): $f = 1852.4$ MHz; $\sigma = 1.49$ mho/m; $\epsilon_r = 53.021$; $\rho = 1000$ kg/m³

Phantom section: Flat Section

Measurement Standard: DASYS (IEEE/IEC/ANSI C63.19-2007)

DASY Configuration:

- Probe: ET3DV6 - SN1644; ConvF(4.69, 4.69, 4.69); Calibrated: 11/15/2011
- Sensor-Surface: 4mm (Mechanical Surface Detection), $z = 2.7, 32.7$
- Electronics: DAE3 Sn472; Calibrated: 3/7/2011
- Phantom: SAM 2; Type: SAM 4.0; Serial: 1080
- DASYS 52 52.8.0(692); SEMCAD X 14.6.4(4989)

Configuration/Touch position -/Area Scan (31x81x1): Measurement grid:
dx=15mm, dy=15mm

[Info: Interpolated medium parameters used for SAR evaluation.](#)

Maximum value of SAR (interpolated) = 1.157 mW/g

Configuration/Touch position -/Zoom Scan (5x5x7) (5x5x7)/Cube 0:

Measurement grid: dx=7.5mm, dy=7.5mm, dz=5mm

Reference Value = 29.847 V/m; Power Drift = 0.06 dB

Peak SAR (extrapolated) = 1.6880

SAR(1 g) = 1.04 mW/g; SAR(10 g) = 0.573 mW/g

[Info: Interpolated medium parameters used for SAR evaluation.](#)

Maximum value of SAR (measured) = 1.168 mW/g

Author Data
Andrew Becker

Dates of Test
February 06 – March 6 , 2012

Test Report No
RTS-5992-1203-12

FCC ID:
L6AREV70UW

IC ID
2503A-REV70UW

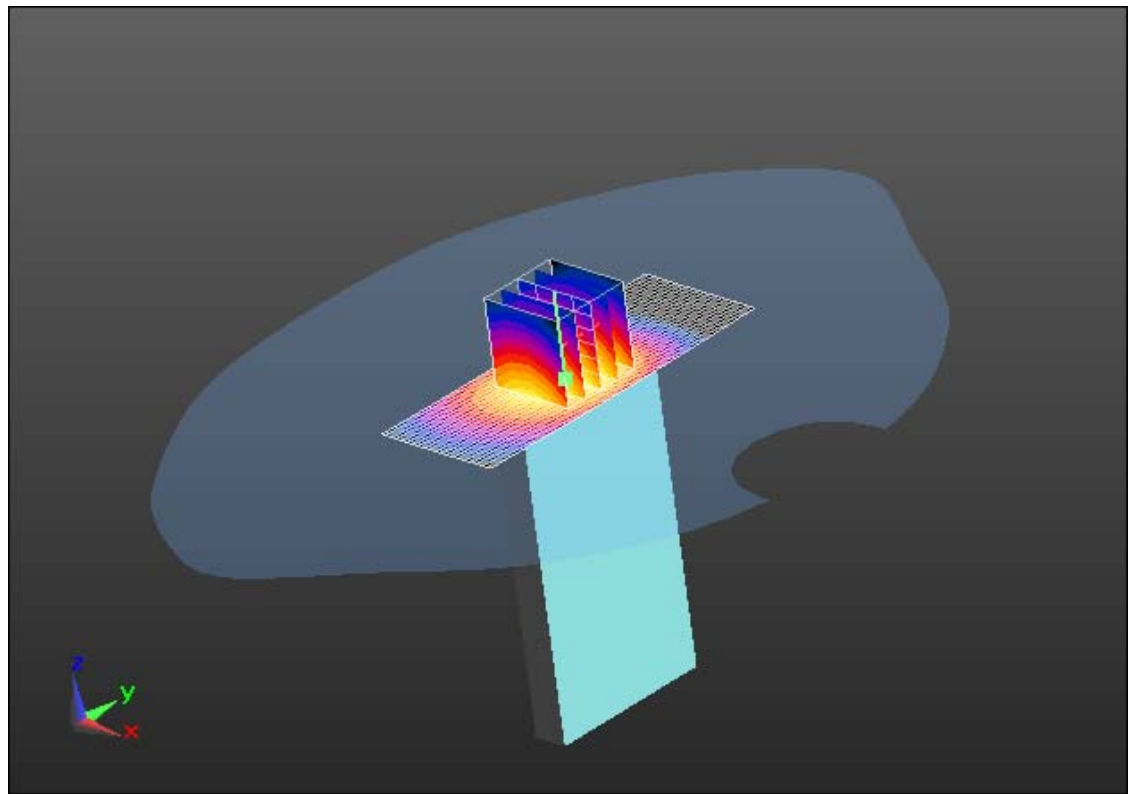
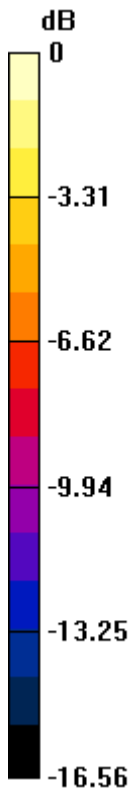

0 dB = 1.170mW/g = 1.36 dB mW/g

	Document Appendix C2 for the BlackBerry® Smartphone Model REV71UW SAR Report			Page 46(64)
	Author Data Andrew Becker	Dates of Test February 06 – March 6 , 2012	Test Report No RTS-5992-1203-12	FCC ID: L6AREV70UW

Date/Time: 2/7/2012 8:06:25 PM

Test Laboratory: RIM Testing Services

MHS_Bottom_UMTS_band_II_mid_chan_amb_temp_22.8_liq_temp_20.8C

DUT: BlackBerry Smartphone; Type: Sample ; Serial: 295EC578

Communication System: WCDMA FDD II; Frequency: 1880 MHz

Medium parameters used: $f = 1880$ MHz; $\sigma = 1.525$ mho/m; $\epsilon_r = 52.799$; $\rho = 1000$ kg/m³

Phantom section: Flat Section

Measurement Standard: DASYS (IEEE/IEC/ANSI C63.19-2007)

DASY Configuration:

- Probe: ET3DV6 - SN1644; ConvF(4.69, 4.69, 4.69); Calibrated: 11/15/2011
- Sensor-Surface: 4mm (Mechanical Surface Detection), $z = 2.7, 32.7$
- Electronics: DAE3 Sn472; Calibrated: 3/7/2011
- Phantom: SAM 2; Type: SAM 4.0; Serial: 1080
- DASYS2 52.8.0(692); SEMCAD X 14.6.4(4989)

Configuration/Touch position -/Area Scan (31x81x1): Measurement grid:
 $dx=15$ mm, $dy=15$ mm

Maximum value of SAR (interpolated) = 1.256 mW/g

Configuration/Touch position -/Zoom Scan (5x5x7) (5x5x7)/Cube 0:

Measurement grid: $dx=7.5$ mm, $dy=7.5$ mm, $dz=5$ mm

Reference Value = 30.675 V/m; Power Drift = 0.08 dB

Peak SAR (extrapolated) = 1.8670

SAR(1 g) = 1.13 mW/g; SAR(10 g) = 0.623 mW/g

Maximum value of SAR (measured) = 1.272 mW/g

Author Data
Andrew Becker

Dates of Test
February 06 – March 6 , 2012

Test Report No
RTS-5992-1203-12

FCC ID:
L6AREV70UW

IC ID
2503A-REV70UW

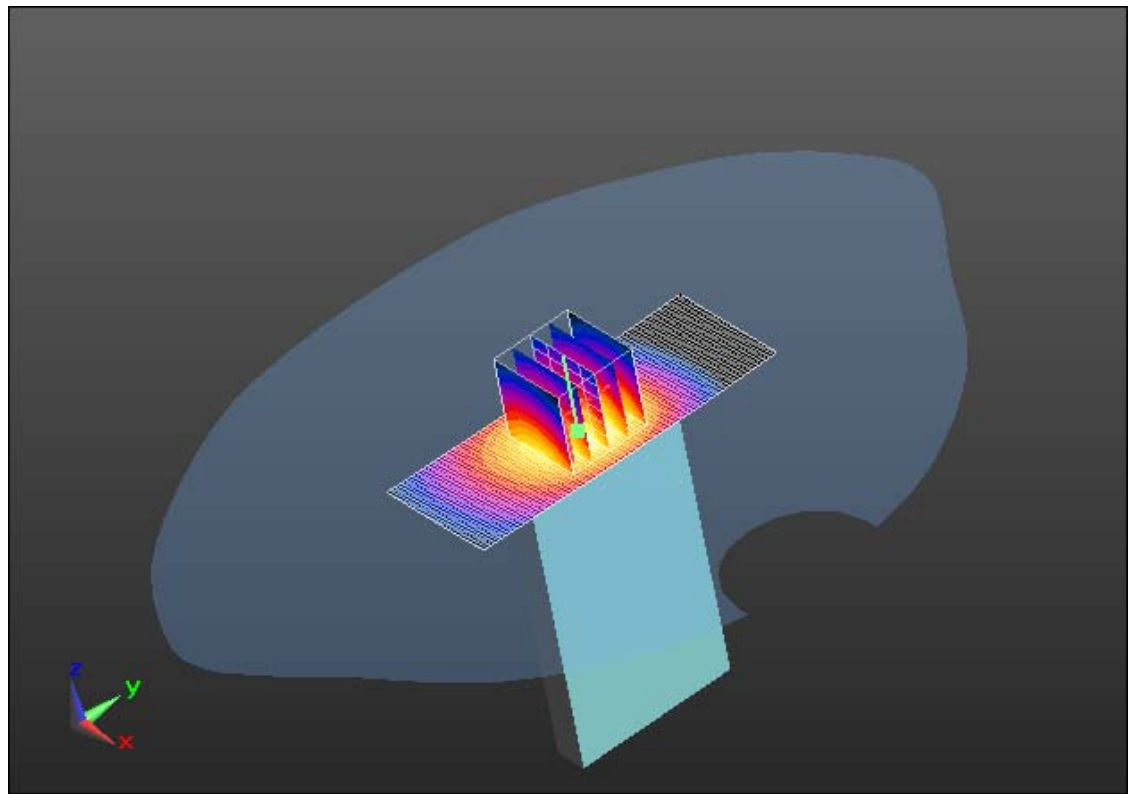
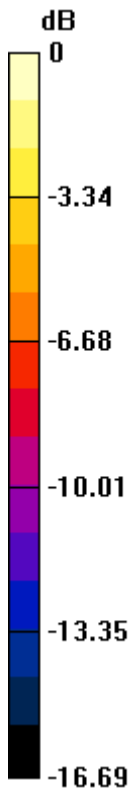

0 dB = 1.270mW/g = 2.08 dB mW/g

	Document Appendix C2 for the BlackBerry® Smartphone Model REV71UW SAR Report			Page 48(64)
	Author Data Andrew Becker	Dates of Test February 06 – March 6 , 2012	Test Report No RTS-5992-1203-12	FCC ID: L6AREV70UW

Date/Time: 2/7/2012 8:36:00 PM

Test Laboratory: RIM Testing Services

MHS_Bottom_UMTS_band_II_high_chan_amb_temp_22.8_liq_temp_20.8C

DUT: BlackBerry Smartphone; Type: Sample ; Serial: 295EC578

Communication System: WCDMA FDD II; Frequency: 1907.6 MHz
Medium parameters used (interpolated): $f = 1907.6$ MHz; $\sigma = 1.562$ mho/m; $\epsilon_r = 52.611$;
 $\rho = 1000$ kg/m³
Phantom section: Flat Section
Measurement Standard: DASYS (IEEE/IEC/ANSI C63.19-2007)

DASY Configuration:

- Probe: ET3DV6 - SN1644; ConvF(4.69, 4.69, 4.69); Calibrated: 11/15/2011
- Sensor-Surface: 4mm (Mechanical Surface Detection), $z = 2.7, 32.7$
- Electronics: DAE3 Sn472; Calibrated: 3/7/2011
- Phantom: SAM 2; Type: SAM 4.0; Serial: 1080
- DASYS 52 52.8.0(692); SEMCAD X 14.6.4(4989)

Configuration/Touch position -/Area Scan (31x81x1): Measurement grid:
dx=15mm, dy=15mm

[Info: Interpolated medium parameters used for SAR evaluation.](#)

Maximum value of SAR (interpolated) = 1.359 mW/g

Configuration/Touch position -/Zoom Scan (5x5x7) (5x5x7)/Cube 0:

Measurement grid: dx=7.5mm, dy=7.5mm, dz=5mm

Reference Value = 32.167 V/m; Power Drift = 0.0054 dB

Peak SAR (extrapolated) = 2.0730

SAR(1 g) = 1.23 mW/g; SAR(10 g) = 0.671 mW/g

[Info: Interpolated medium parameters used for SAR evaluation.](#)

Maximum value of SAR (measured) = 1.376 mW/g

	Document Appendix C2 for the BlackBerry® Smartphone Model REV71UW SAR Report			Page 49(64)
	Author Data Andrew Becker	Dates of Test February 06 – March 6 , 2012	Test Report No RTS-5992-1203-12	FCC ID: L6AREV70UW

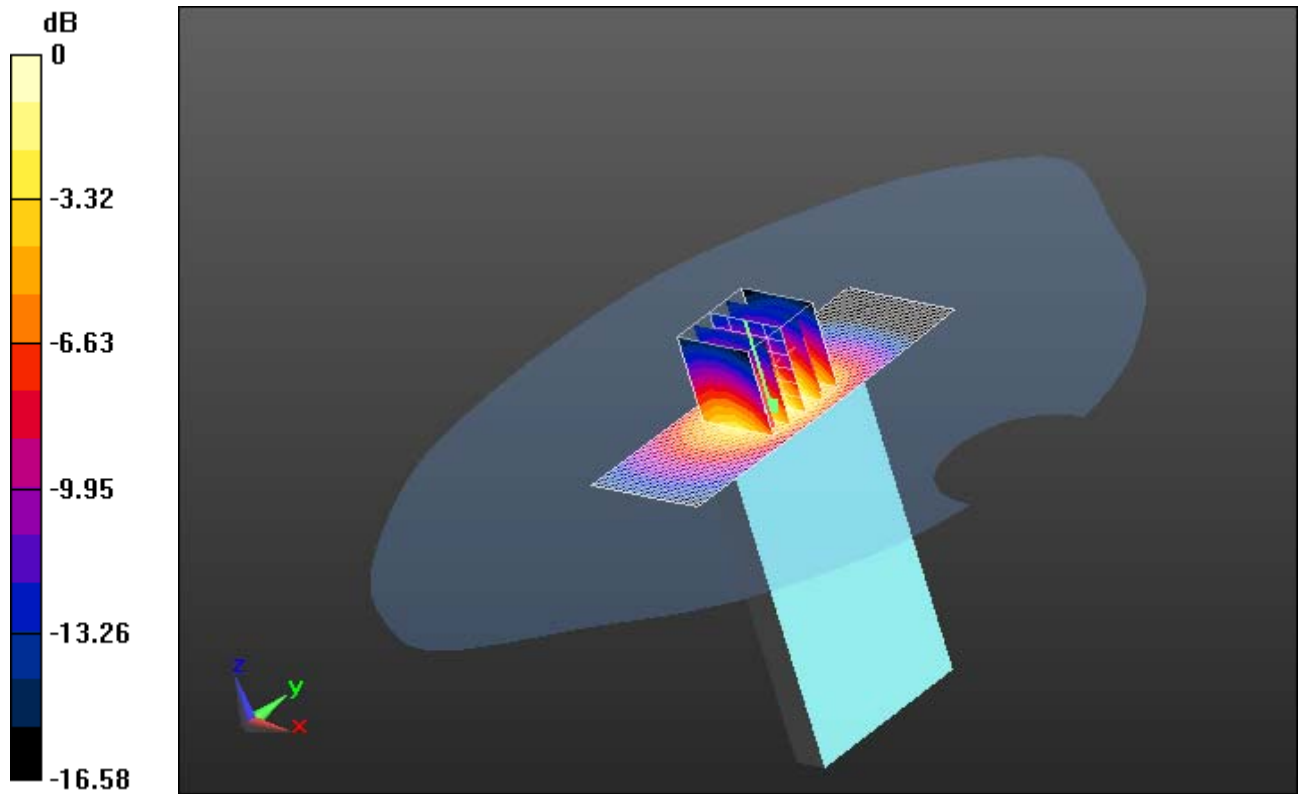

0 dB = 1.380mW/g = 2.80 dB mW/g

	Document Appendix C2 for the BlackBerry® Smartphone Model REV71UW SAR Report			Page 50(64)
	Author Data Andrew Becker	Dates of Test February 06 – March 6 , 2012	Test Report No RTS-5992-1203-12	FCC ID: L6AREV70UW

Date/Time: 2/16/2012 1:52:52 PM

Test Laboratory: RIM Testing Services

MHS_Back_802.11b_low_chan_amb_temp_22.6C_liq_temp_20.7C

DUT: BlackBerry Smartphone; Type: Sample ; Serial: 295B50C4

Communication System: 802.11 b (2450); Frequency: 2412 MHz

Medium parameters used (interpolated): $f = 2412$ MHz; $\sigma = 1.944$ mho/m; $\epsilon_r = 51.535$; $\rho = 1000$ kg/m³

Phantom section: Flat Section

Measurement Standard: DASYS (IEEE/IEC/ANSI C63.19-2007)

DASY Configuration:

- Probe: ES3DV3 - SN3225; ConvF(4.3, 4.3, 4.3); Calibrated: 1/11/2012
- Sensor-Surface: 3mm (Mechanical Surface Detection), $z = 2.0, 32.0$
- Electronics: DAE3 Sn472; Calibrated: 3/7/2011
- Phantom: SAM 2; Type: SAM 4.0; Serial: 1080
- DASYS 52.8.0(692); SEMCAD X 14.6.4(4989)

Configuration/Touch position -/Area Scan (61x91x1): Measurement grid: $dx=15$ mm, $dy=15$ mm

[Info: Interpolated medium parameters used for SAR evaluation.](#)

Maximum value of SAR (interpolated) = 0.252 mW/g

Configuration/Touch position -/Zoom Scan (5x5x7) (5x5x7)/Cube 0:

Measurement grid: $dx=7.5$ mm, $dy=7.5$ mm, $dz=5$ mm

Reference Value = 3.892 V/m; Power Drift = -0.07 dB

Peak SAR (extrapolated) = 0.3450

SAR(1 g) = 0.193 mW/g; SAR(10 g) = 0.110 mW/g

[Info: Interpolated medium parameters used for SAR evaluation.](#)

Maximum value of SAR (measured) = 0.235 mW/g

	Document Appendix C2 for the BlackBerry® Smartphone Model REV71UW SAR Report			Page 51(64)
	Author Data Andrew Becker	Dates of Test February 06 – March 6 , 2012	Test Report No RTS-5992-1203-12	FCC ID: L6AREV70UW

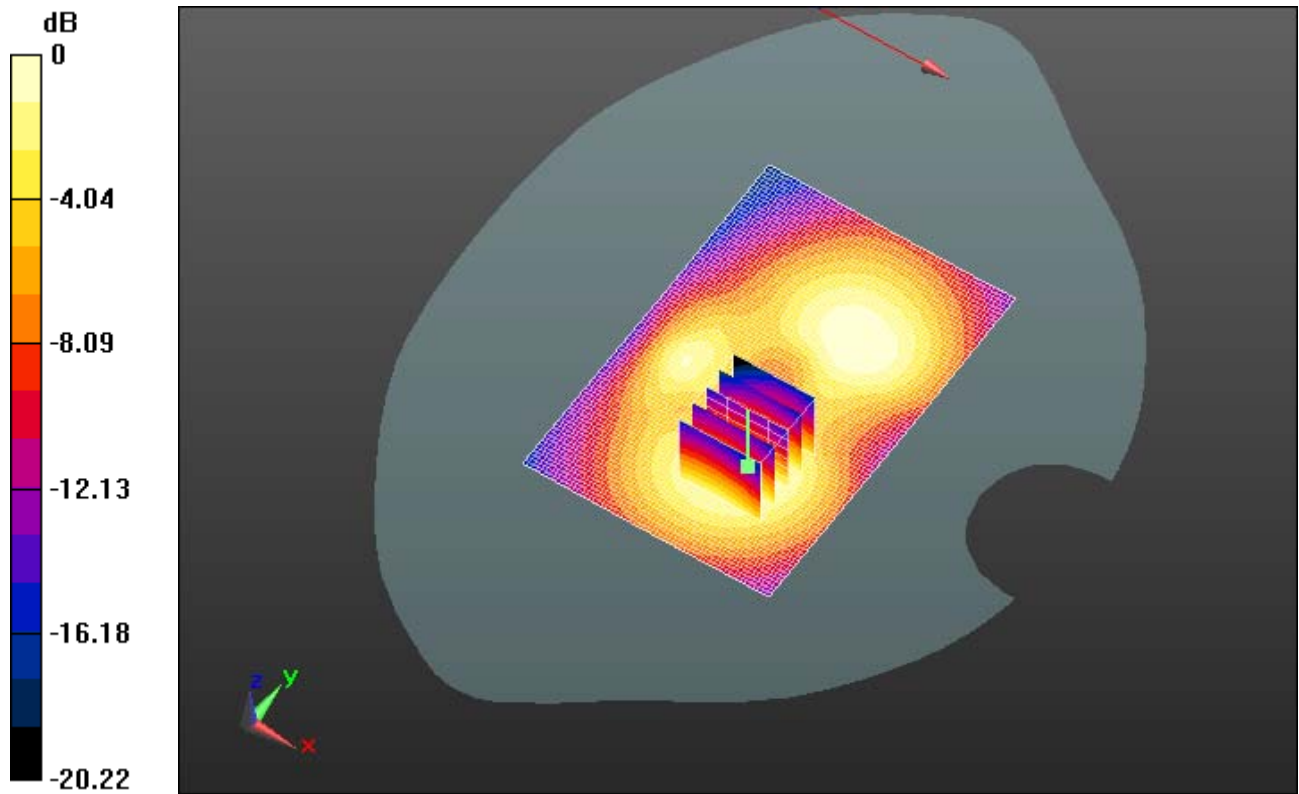

0 dB = 0.240mW/g = -12.40 dB mW/g

	Document Appendix C2 for the BlackBerry® Smartphone Model REV71UW SAR Report			Page 52(64)
	Author Data Andrew Becker	Dates of Test February 06 – March 6 , 2012	Test Report No RTS-5992-1203-12	FCC ID: L6AREV70UW

Date/Time: 2/16/2012 2:28:46 PM

Test Laboratory: RIM Testing Services

MHS_Back_802.11b_mid_chan_amb_temp_22.6C_liq_temp_20.7C

DUT: BlackBerry Smartphone; Type: Sample ; Serial: 295B50C4

Communication System: 802.11 b (2450); Frequency: 2437 MHz

Medium parameters used (interpolated): $f = 2437$ MHz; $\sigma = 1.98$ mho/m; $\epsilon_r = 51.458$; $\rho = 1000$ kg/m³

Phantom section: Flat Section

Measurement Standard: DASYS (IEEE/IEC/ANSI C63.19-2007)

DASY Configuration:

- Probe: ES3DV3 - SN3225; ConvF(4.3, 4.3, 4.3); Calibrated: 1/11/2012
- Sensor-Surface: 3mm (Mechanical Surface Detection), $z = 2.0, 32.0$
- Electronics: DAE3 Sn472; Calibrated: 3/7/2011
- Phantom: SAM 2; Type: SAM 4.0; Serial: 1080
- DASYS 52.8.0(692); SEMCAD X 14.6.4(4989)

Configuration/Touch position -/Area Scan (61x91x1): Measurement grid:
 $dx=15$ mm, $dy=15$ mm

[Info: Interpolated medium parameters used for SAR evaluation.](#)

Maximum value of SAR (interpolated) = 0.333 mW/g

Configuration/Touch position -/Zoom Scan (5x5x7) (5x5x7)/Cube 0:

Measurement grid: $dx=7.5$ mm, $dy=7.5$ mm, $dz=5$ mm

Reference Value = 3.834 V/m; Power Drift = 0.10 dB

Peak SAR (extrapolated) = 0.4770

SAR(1 g) = 0.260 mW/g; SAR(10 g) = 0.146 mW/g

[Info: Interpolated medium parameters used for SAR evaluation.](#)

Maximum value of SAR (measured) = 0.317 mW/g

Author Data
Andrew Becker

Dates of Test
February 06 – March 6 , 2012

Test Report No
RTS-5992-1203-12

FCC ID:
L6AREV70UW

IC ID
2503A-REV70UW

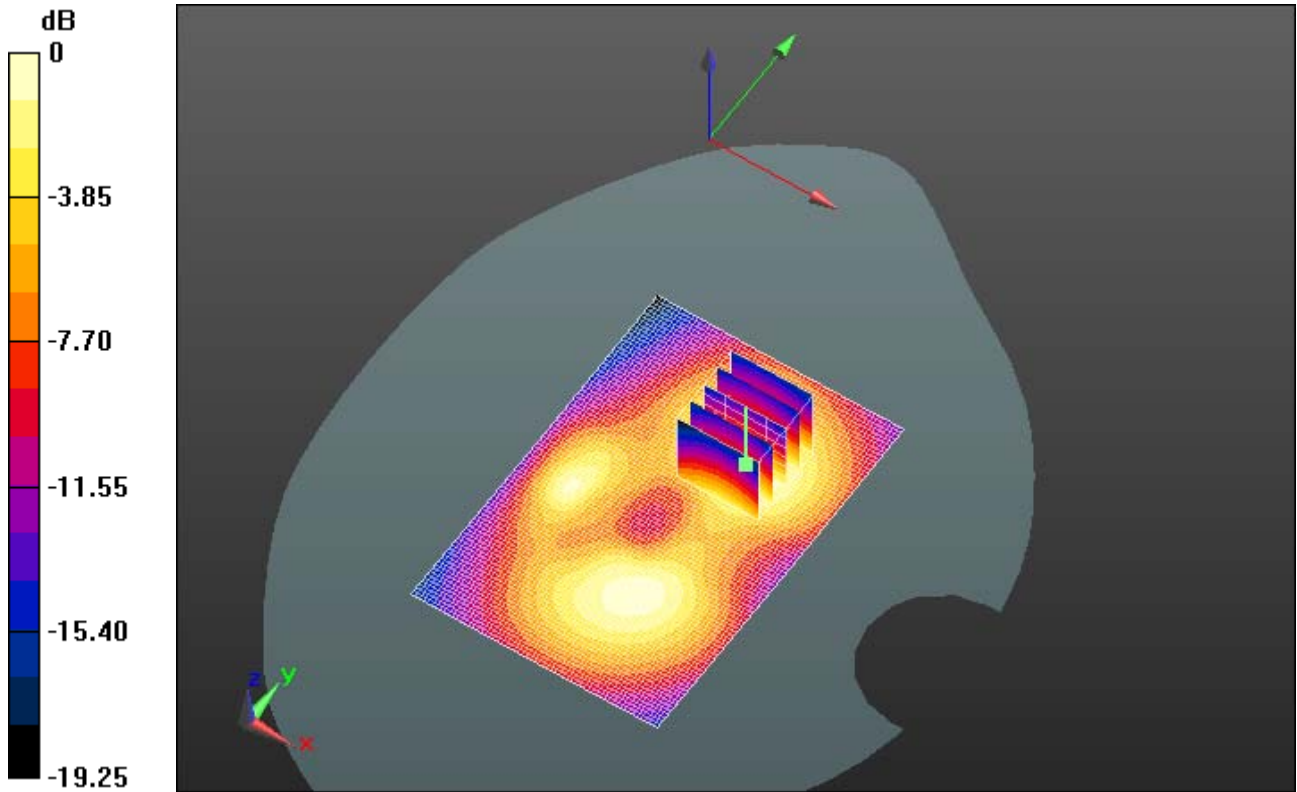

0 dB = 0.320mW/g = -9.90 dB mW/g

	Document Appendix C2 for the BlackBerry® Smartphone Model REV71UW SAR Report			Page 54(64)
	Author Data Andrew Becker	Dates of Test February 06 – March 6 , 2012	Test Report No RTS-5992-1203-12	FCC ID: L6AREV70UW

Date/Time: 2/16/2012 2:10:11 PM

Test Laboratory: RIM Testing Services

MHS_Back_802.11b_high_chan_amb_temp_22.6C_liq_temp_20.7C

DUT: BlackBerry Smartphone; Type: Sample ; Serial: 295B50C4

Communication System: 802.11 b (2450); Frequency: 2462 MHz

Medium parameters used (interpolated): $f = 2462$ MHz; $\sigma = 2.015$ mho/m; $\epsilon_r = 51.39$; $\rho = 1000$ kg/m³

Phantom section: Flat Section

Measurement Standard: DASYS (IEEE/IEC/ANSI C63.19-2007)

DASY Configuration:

- Probe: ES3DV3 - SN3225; ConvF(4.3, 4.3, 4.3); Calibrated: 1/11/2012
- Sensor-Surface: 3mm (Mechanical Surface Detection), $z = 2.0, 32.0$
- Electronics: DAE3 Sn472; Calibrated: 3/7/2011
- Phantom: SAM 2; Type: SAM 4.0; Serial: 1080
- DASYS 52.8.0(692); SEMCAD X 14.6.4(4989)

Configuration/Touch position -/Area Scan (61x91x1): Measurement grid:
 $dx=15$ mm, $dy=15$ mm

[Info: Interpolated medium parameters used for SAR evaluation.](#)

Maximum value of SAR (interpolated) = 0.336 mW/g

Configuration/Touch position -/Zoom Scan (5x5x7) (5x5x7)/Cube 0:

Measurement grid: $dx=7.5$ mm, $dy=7.5$ mm, $dz=5$ mm

Reference Value = 4.386 V/m; Power Drift = -0.54 dB

Peak SAR (extrapolated) = 0.5030

SAR(1 g) = 0.272 mW/g; SAR(10 g) = 0.150 mW/g

[Info: Interpolated medium parameters used for SAR evaluation.](#)

Maximum value of SAR (measured) = 0.333 mW/g

	Document Appendix C2 for the BlackBerry® Smartphone Model REV71UW SAR Report			Page 55(64)
	Author Data Andrew Becker	Dates of Test February 06 – March 6 , 2012	Test Report No RTS-5992-1203-12	FCC ID: L6AREV70UW

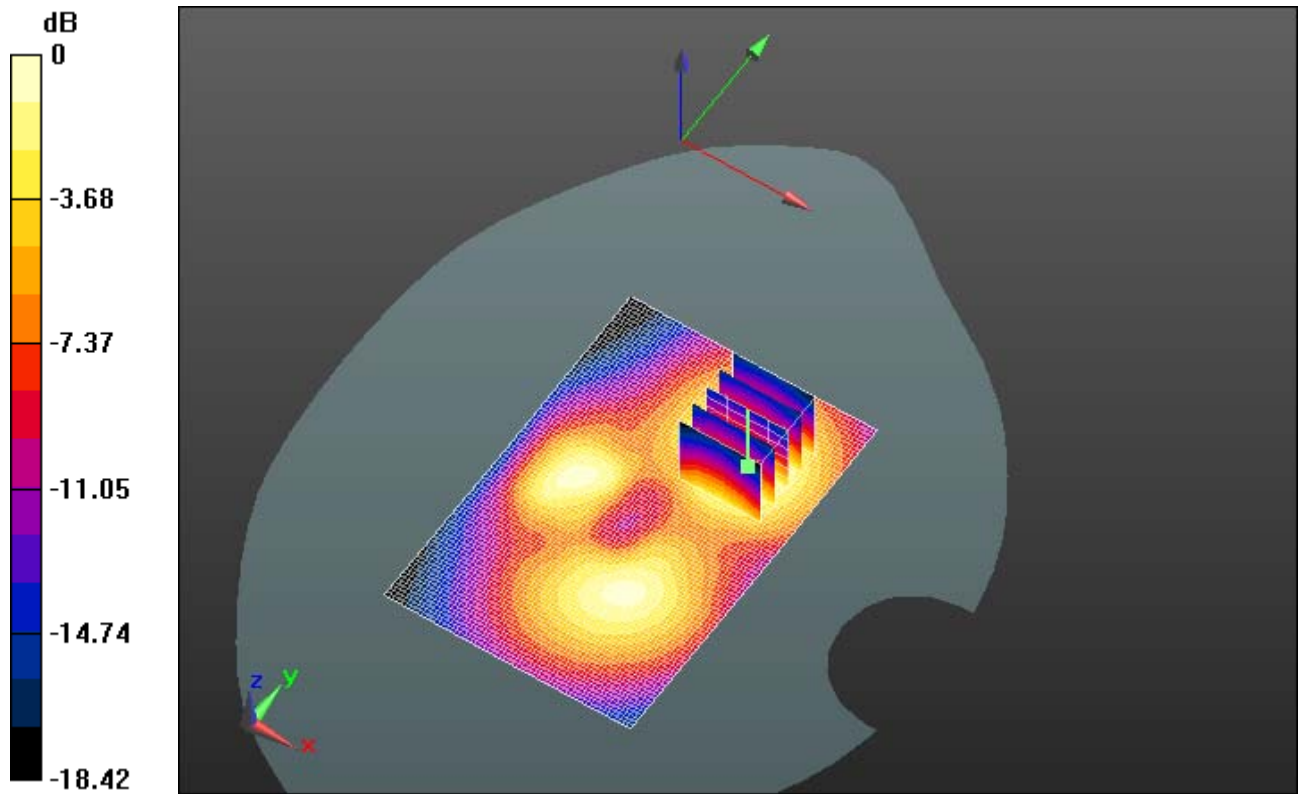

0 dB = 0.330mW/g = -9.63 dB mW/g

	Document Appendix C2 for the BlackBerry® Smartphone Model REV71UW SAR Report			Page 56(64)
	Author Data Andrew Becker	Dates of Test February 06 – March 6 , 2012	Test Report No RTS-5992-1203-12	FCC ID: L6AREV70UW

Date/Time: 2/16/2012 2:47:47 PM

Test Laboratory: RIM Testing Services

MHS_Front_802.11b_high_chan_amb_temp_22.6C_liq_temp_20.7C

DUT: BlackBerry Smartphone; Type: Sample ; Serial: 295B50C4

Communication System: 802.11 b (2450); Frequency: 2462 MHz

Medium parameters used (interpolated): $f = 2462$ MHz; $\sigma = 2.015$ mho/m; $\epsilon_r = 51.39$; $\rho = 1000$ kg/m³

Phantom section: Flat Section

Measurement Standard: DASYS (IEEE/IEC/ANSI C63.19-2007)

DASY Configuration:

- Probe: ES3DV3 - SN3225; ConvF(4.3, 4.3, 4.3); Calibrated: 1/11/2012
- Sensor-Surface: 3mm (Mechanical Surface Detection), $z = 2.0, 32.0$
- Electronics: DAE3 Sn472; Calibrated: 3/7/2011
- Phantom: SAM 2; Type: SAM 4.0; Serial: 1080
- DASYS 52.8.0(692); SEMCAD X 14.6.4(4989)

Configuration/Touch position -/Area Scan (61x91x1): Measurement grid:
 $dx=15$ mm, $dy=15$ mm

[Info: Interpolated medium parameters used for SAR evaluation.](#)

Maximum value of SAR (interpolated) = 0.132 mW/g

Configuration/Touch position -/Zoom Scan (5x5x7) (5x5x7)/Cube 0:

Measurement grid: $dx=7.5$ mm, $dy=7.5$ mm, $dz=5$ mm

Reference Value = 2.471 V/m; Power Drift = -0.12 dB

Peak SAR (extrapolated) = 0.1720

SAR(1 g) = 0.095 mW/g; SAR(10 g) = 0.055 mW/g

[Info: Interpolated medium parameters used for SAR evaluation.](#)

Maximum value of SAR (measured) = 0.113 mW/g

Author Data
Andrew Becker

Dates of Test
February 06 – March 6 , 2012

Test Report No
RTS-5992-1203-12

FCC ID:
L6AREV70UW

IC ID
2503A-REV70UW

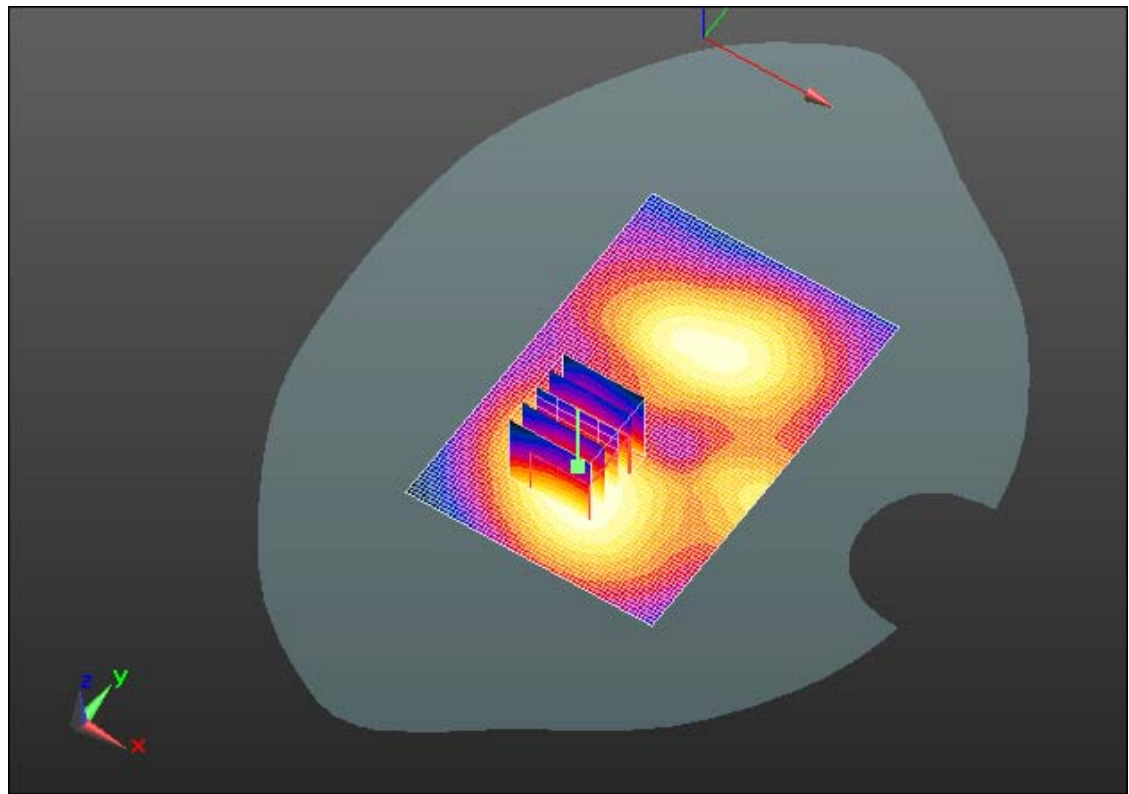
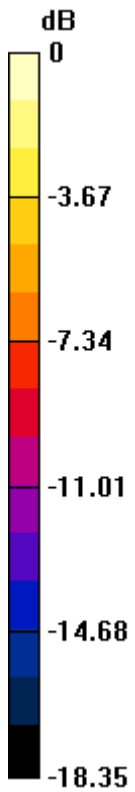

0 dB = 0.110mW/g = -19.17 dB mW/g

	Document Appendix C2 for the BlackBerry® Smartphone Model REV71UW SAR Report			Page 58(64)
	Author Data Andrew Becker	Dates of Test February 06 – March 6 , 2012	Test Report No RTS-5992-1203-12	FCC ID: L6AREV70UW

Date/Time: 2/16/2012 3:28:16 PM

Test Laboratory: RIM Testing Services

MHS_Right_802.11b_high_chan_amb_temp_22.5C_liq_temp_20.6C

DUT: BlackBerry Smartphone; Type: Sample ; Serial: 295B50C4

Communication System: 802.11 b (2450); Frequency: 2462 MHz

Medium parameters used (interpolated): $f = 2462$ MHz; $\sigma = 2.015$ mho/m; $\epsilon_r = 51.39$; $\rho = 1000$ kg/m³

Phantom section: Flat Section

Measurement Standard: DASYS (IEEE/IEC/ANSI C63.19-2007)

DASY Configuration:

- Probe: ES3DV3 - SN3225; ConvF(4.3, 4.3, 4.3); Calibrated: 1/11/2012
- Sensor-Surface: 3mm (Mechanical Surface Detection), $z = 2.0, 32.0$
- Electronics: DAE3 Sn472; Calibrated: 3/7/2011
- Phantom: SAM 2; Type: SAM 4.0; Serial: 1080
- DASYS 52.8.0(692); SEMCAD X 14.6.4(4989)

Configuration/Touch position -/Area Scan (31x101x1): Measurement grid:
 $dx=15$ mm, $dy=15$ mm

[Info: Interpolated medium parameters used for SAR evaluation.](#)

Maximum value of SAR (interpolated) = 0.119 mW/g

Configuration/Touch position -/Zoom Scan (5x5x7) (5x5x7)/Cube 0:

Measurement grid: $dx=7.5$ mm, $dy=7.5$ mm, $dz=5$ mm

Reference Value = 4.145 V/m; Power Drift = 0.03 dB

Peak SAR (extrapolated) = 0.1820

SAR(1 g) = 0.097 mW/g; SAR(10 g) = 0.053 mW/g

[Info: Interpolated medium parameters used for SAR evaluation.](#)

Maximum value of SAR (measured) = 0.118 mW/g

Author Data
Andrew Becker

Dates of Test
February 06 – March 6 , 2012

Test Report No
RTS-5992-1203-12

FCC ID:
L6AREV70UW

IC ID
2503A-REV70UW

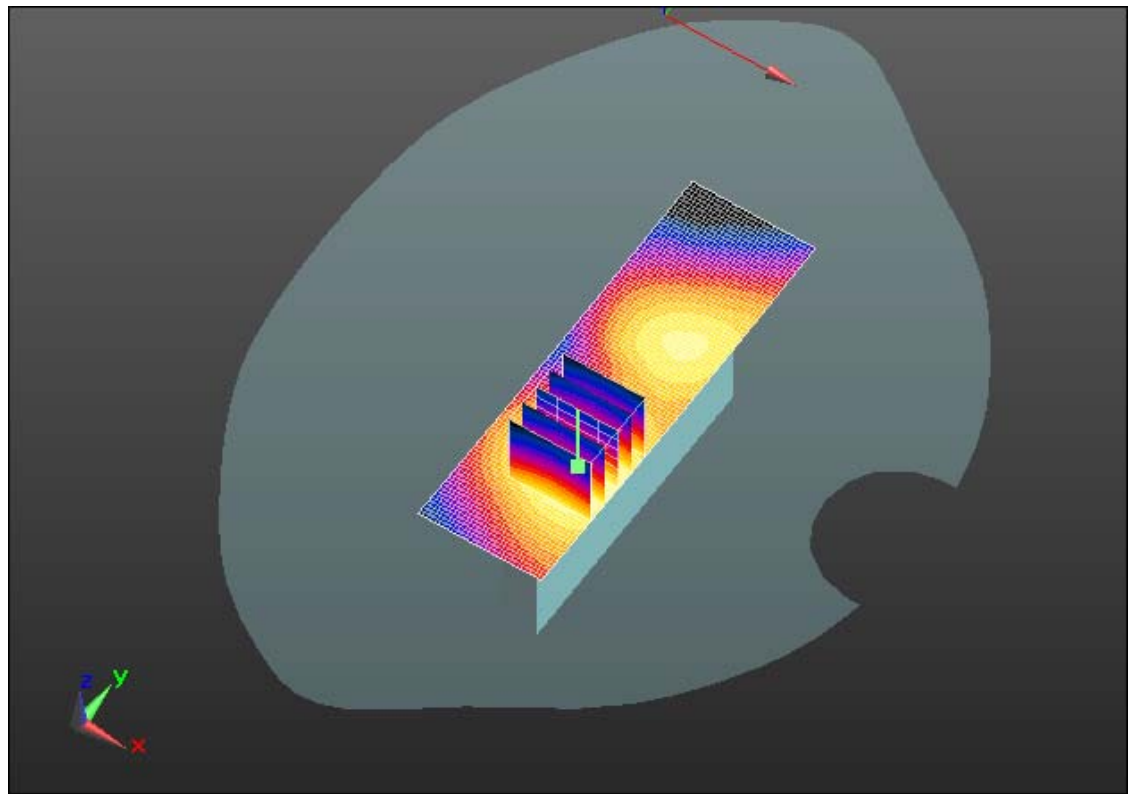
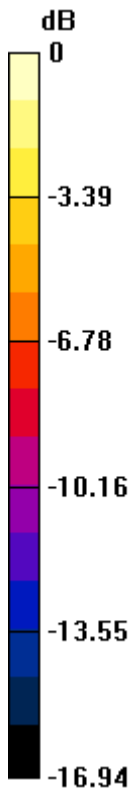

0 dB = 0.120mW/g = -18.42 dB mW/g

	Document Appendix C2 for the BlackBerry® Smartphone Model REV71UW SAR Report			Page 60(64)
	Author Data Andrew Becker	Dates of Test February 06 – March 6 , 2012	Test Report No RTS-5992-1203-12	FCC ID: L6AREV70UW

Date/Time: 2/16/2012 3:11:22 PM

Test Laboratory: RIM Testing Services

MHS_Left_802.11b_high_chan_amb_temp_22.5C_liq_temp_20.6C

DUT: BlackBerry Smartphone; Type: Sample ; Serial: 295B50C4

Communication System: 802.11 b (2450); Frequency: 2462 MHz

Medium parameters used (interpolated): $f = 2462$ MHz; $\sigma = 2.015$ mho/m; $\epsilon_r = 51.39$; $\rho = 1000$ kg/m³

Phantom section: Flat Section

Measurement Standard: DASYS (IEEE/IEC/ANSI C63.19-2007)

DASY Configuration:

- Probe: ES3DV3 - SN3225; ConvF(4.3, 4.3, 4.3); Calibrated: 1/11/2012
- Sensor-Surface: 3mm (Mechanical Surface Detection), $z = 2.0, 32.0$
- Electronics: DAE3 Sn472; Calibrated: 3/7/2011
- Phantom: SAM 2; Type: SAM 4.0; Serial: 1080
- DASYS 52.8.0(692); SEMCAD X 14.6.4(4989)

Configuration/Touch position -/Area Scan (31x101x1): Measurement grid:
 $dx=15$ mm, $dy=15$ mm

[Info: Interpolated medium parameters used for SAR evaluation.](#)

Maximum value of SAR (interpolated) = 0.281 mW/g

Configuration/Touch position -/Zoom Scan (5x5x7) (5x5x7)/Cube 0:

Measurement grid: $dx=7.5$ mm, $dy=7.5$ mm, $dz=5$ mm

Reference Value = 9.157 V/m; Power Drift = 0.07 dB

Peak SAR (extrapolated) = 0.5140

SAR(1 g) = 0.243 mW/g; SAR(10 g) = 0.115 mW/g

[Info: Interpolated medium parameters used for SAR evaluation.](#)

Maximum value of SAR (measured) = 0.309 mW/g

Author Data
Andrew Becker

Dates of Test
February 06 – March 6 , 2012

Test Report No
RTS-5992-1203-12

FCC ID:
L6AREV70UW

IC ID
2503A-REV70UW

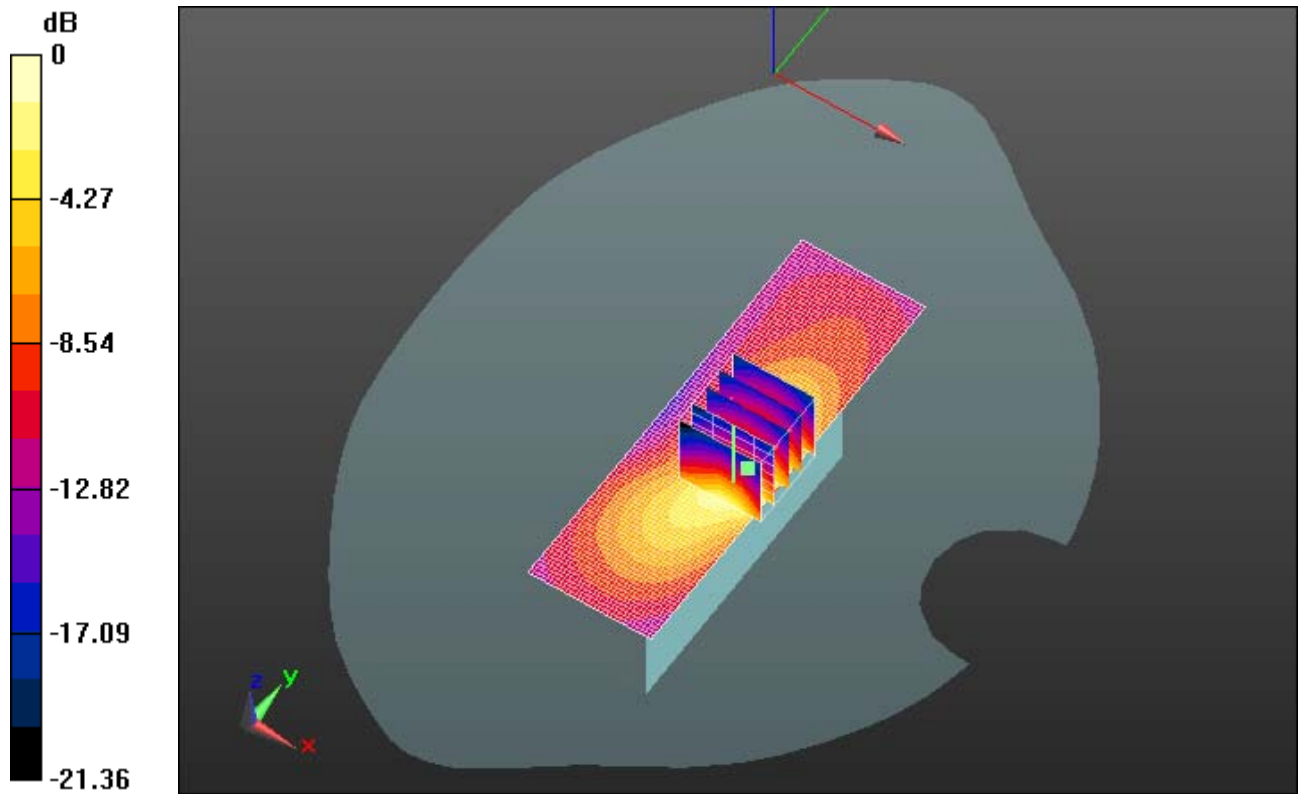

0 dB = 0.310mW/g = -10.17 dB mW/g

	Document Appendix C2 for the BlackBerry® Smartphone Model REV71UW SAR Report			Page 62(64)
	Author Data Andrew Becker	Dates of Test February 06 – March 6 , 2012	Test Report No RTS-5992-1203-12	FCC ID: L6AREV70UW

Date/Time: 2/16/2012 3:48:14 PM

Test Laboratory: RIM Testing Services

MHS_Bottom_802.11b_high_chan_amb_temp_22.4_liq_temp_20.6C

DUT: BlackBerry Smartphone; Type: Sample ; Serial: 295B50C4

Communication System: 802.11 b (2450); Frequency: 2462 MHz

Medium parameters used (interpolated): $f = 2462$ MHz; $\sigma = 2.015$ mho/m; $\epsilon_r = 51.39$; $\rho = 1000$ kg/m³

Phantom section: Flat Section

Measurement Standard: DASYS (IEEE/IEC/ANSI C63.19-2007)

DASY Configuration:

- Probe: ES3DV3 - SN3225; ConvF(4.3, 4.3, 4.3); Calibrated: 1/11/2012
- Sensor-Surface: 3mm (Mechanical Surface Detection), $z = 2.0, 32.0$
- Electronics: DAE3 Sn472; Calibrated: 3/7/2011
- Phantom: SAM 2; Type: SAM 4.0; Serial: 1080
- DASYS 52.8.0(692); SEMCAD X 14.6.4(4989)

Configuration/Touch position -/Area Scan (31x81x1): Measurement grid:
 $dx=15$ mm, $dy=15$ mm

[Info: Interpolated medium parameters used for SAR evaluation.](#)

Maximum value of SAR (interpolated) = 0.064 mW/g

Configuration/Touch position -/Zoom Scan (5x5x7) (5x5x7)/Cube 0:

Measurement grid: $dx=7.5$ mm, $dy=7.5$ mm, $dz=5$ mm

Reference Value = 5.665 V/m; Power Drift = 0.04 dB

Peak SAR (extrapolated) = 0.0940

SAR(1 g) = 0.050 mW/g; SAR(10 g) = 0.028 mW/g

[Info: Interpolated medium parameters used for SAR evaluation.](#)

Maximum value of SAR (measured) = 0.062 mW/g

Author Data
Andrew Becker

Dates of Test
February 06 – March 6 , 2012

Test Report No
RTS-5992-1203-12

FCC ID:
L6AREV70UW

IC ID
2503A-REV70UW

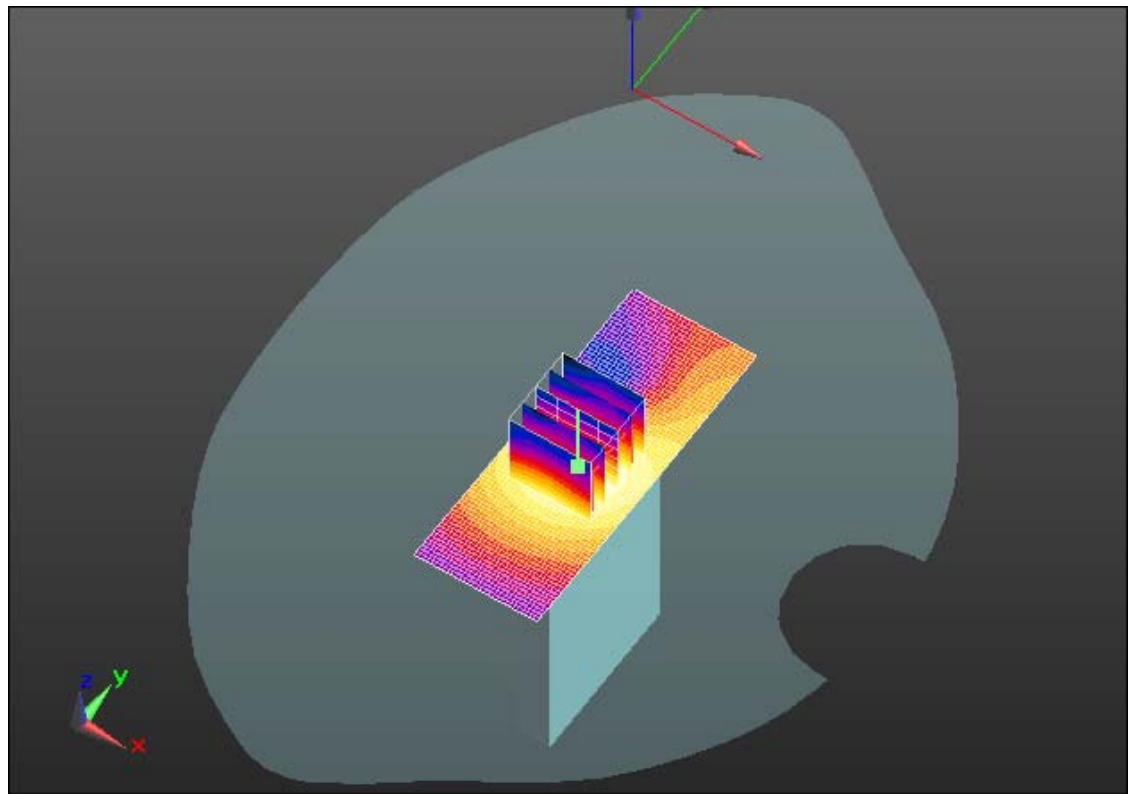
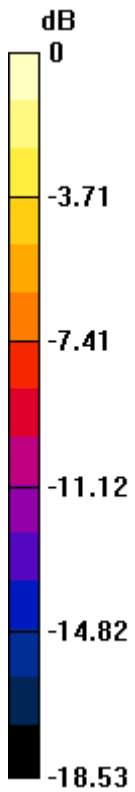

0 dB = 0.060mW/g = -24.44 dB mW/g

	Document Appendix C2 for the BlackBerry® Smartphone Model REV71UW SAR Report			Page 64(64)
	Author Data Andrew Becker	Dates of Test February 06 – March 6 , 2012	Test Report No RTS-5992-1203-12	FCC ID: L6AREV70UW

Z axis plot for the worst case body configuration

