







TEST REPORT  
No.: 2-0023-11-1-7b

According to:  
**FCC Regulations**  
Part 15.207  
Part 15.109 & 15.209  
Part 15.247  
**IC Regulations**  
RSS-Gen: Issue 3  
RSS-210: Issue 8

for  
Research In Motion Limited

Smartphone REA71UW  
FCC-ID: L6AREA70UW  
IC: 2503A-REA70UW

Laboratory Accreditation and Listings			
 <p>Deutsche Akkreditierungsstelle D-PL-12047-01-01</p>	 <p>Reg. No.: 736496 MRA US-EU 0003</p>	 <p>Industry Canada Reg. No.: 3462D-1 Reg. No.: 3462D-2 Reg. No.: 3462D-3</p>	 <p>Voluntary Controls for Electromagnetic Emissions Reg. No.: R-2665, R-2666 C-2914, T-1967, G-301</p>
 <p>AUTHORIZED RF LABORATORY</p>	 <p>LAB CODE 20011130-00</p>		
accredited according to DIN EN ISO/IEC 17025			
<p><b>CETECOM GmbH</b> Laboratory Radio Communications &amp; Electromagnetic Compatibility Im Teelbruch 116 • 45219 Essen • Germany Registered in Essen, Germany, Reg. No.: HRB Essen 8984 Tel.: + 49 (0) 20 54 / 95 19-954 • Fax: + 49 (0) 20 54 / 95 19-964 E-mail: info@cetecom.com • Internet: www.cetecom.com</p>			

## Table of contents

<b>1. SUMMARY OF TEST RESULTS.....</b>	<b>3</b>
1.1. Tests overview FCC and Canada IC Standards (RSS) .....	3
<b>2. ADMINISTRATIVE DATA .....</b>	<b>5</b>
2.1. Identification of the testing laboratory.....	5
2.2. Test location .....	5
2.3. Organizational items.....	5
2.4. Applicant’s details .....	5
2.5. Manufacturer’s details .....	5
<b>3. EQUIPMENT UNDER TEST (EUT).....</b>	<b>6</b>
3.1. Additional declaration and description of main EUT .....	6
3.2. IEEE 802.11 Overview: Modulation and Data Rates .....	7
3.3. EUT: Type, S/N etc. and short descriptions used in this test report .....	8
3.4. Auxiliary Equipment (AE): Type, S/N etc. and short descriptions.....	8
3.5. EUT set-ups .....	9
3.6. EUT operating modes .....	9
<b>4. DESCRIPTION OF TEST SET-UP’S.....</b>	<b>10</b>
4.1. Test Set-up for conducted measurements .....	10
4.2. Test set-up for radiated measurements .....	11
<b>5. MEASUREMENTS .....</b>	<b>12</b>
5.1. 6 dB Bandwidth .....	12
5.2. 20dBc Emission specification.....	14
5.3. Power specification.....	19
5.4. Power Spectral Density.....	23
5.5. Transmitter frequency stability .....	24
5.6. Conducted emissions on AC-Power lines.....	25
5.7. Radiated field strength emissions below 30 MHz .....	27
5.8. Radiated field strength emissions .....	31
5.9. Radiated emissions, above 1GHz .....	35
5.10. Carrier field strength and radiated band-edge compliance measurements.....	50
5.11. Measurement uncertainties .....	52
<b>6. ACCREDITATION DETAILS OF CETECOM’S LABORATORIES AND TEST SITES .....</b>	<b>53</b>
<b>7. INSTRUMENTS AND ANCILLARY.....</b>	<b>54</b>
7.1. Used equipment “CTC” .....	54
<b>8. CORRECTION FACTORS DUE TO REDUCED MEAS. DISTANCE (F&lt; 30 MHZ).....</b>	<b>58</b>

## Table of annex

## Total pages

DOCUMENT TR2-0023-11-7B-A1.PDF: MEASUREMENT DIAGRAMS

224

## 1. Summary of test results

The test results apply exclusively to the test samples as presented in chapter 3.1. The CETECOM GmbH does not assume responsibility for any conclusions and generalizations taken in conjunction with other specimens or samples of the type of the item presented to tests.

The presented mobile phone integrates a 802.11 b/g/n WLAN transmitter at 2.412 to 2.462 GHz frequency range. Other wireless technologies have not been tested within this test report.

Following test cases have been performed to show compliance with valid Part 15.207/15.209/15.247 of the FCC CFR 47 Rules, Edition 1<sup>st</sup> October 2010 and IC RSS-210 Issue 8/RSS-Gen Issue 3 standards.

### 1.1. Tests overview FCC and Canada IC Standards (RSS)

TEST CASES	PORT	REFERENCES & LIMITS			EUT set-up	EUT operating mode	Result
		FCC Standard	RSS Section	TEST LIMIT			
TX-Mode							
6dB bandwidth	Antenna terminal (conducted)	§15.247(a)(2)	RSS-210 Issue 8: A8.2 (a) RSS-Gen Issue 3: Chapter 4.6.2	≥ 500 kHz for DTS systems	1	1	Passed
99% occupied bandwidth	Antenna terminal (conducted)	--	RSS-Gen Issue 3: Chapter 4.6.1	99% Power bandwidth	1	1	for Information only
Transmitter Peak output power	Antenna terminal (conducted)	§15.247(b)(1)	RSS-210 Issue 8: A8.4 (4)	1 Watt Peak (or 0.125 mW Peak)	1	1	Passed
Transmitter Peak output power radiated	Cabinet (radiated)	§15.247(b)(4)	RSS-210 Issue 8:A8.4 (4)	< 4 Watt (EIRP) for antenna with directional gain less 6dBi	2	1	Passed
Out-Of-Band RF- emissions Band-Edge emissions	Antenna terminal (conducted)	§15.247 (d)	RSS-210 Issue 8: A8.5	20 dBc	1	1	Passed
Power spectral density	Antenna terminal (conducted)	§15.247(e)	RSS-210 Issue 8: A8.2 (b)	8dBm in any 3kHz band	1	1	Passed
Transmitter frequency stability	Antenna terminal (conducted)	--	RSS-Gen, Issue 3, Chapter 4.7	Operation within designated operational band	1	2	Passed
General field strength emissions + restricted bands	Cabinet + Interconnecting cables (radiated)	§15.247 (d) §15.205 §15.209	RSS-210 Issue 8, Chapter 2.5 RSS-Gen: Issue 3: §7.2.5 Table 5+6	Emissions in restricted bands must meet the general field-strength radiated limits	2	1	Passed
AC-Power Lines Conducted Emissions	AC-Power lines	§15.207	RSS-Gen, Issue 3: Chapter 7.2.4, Table 4	FCC §15.107 class B limits §15.207 limits IC: Table 4, Chapter 7.2.4	3	4+5	Passed

RX Mode							
RECEIVER	Cabinet + Interconnecting cables (radiated)	§15.109 §15.33 §15.35	RSS-Gen, Issue 3: Chapter 6.1	FCC 15.109 class B limits  IC-limits: Table 1, Chapter 6	3	3+5	Passed

Remark: due to customer request no EUT photographs should be inside of this test report.

**ATTESTATION:**

I declare that all measurements were performed by me or under my supervision and that all measurements have been performed and are correct to my best knowledge and belief to Industry Canada standards. All requirements as shown in above table are met in accordance with enumerated standards.



.....  
Dipl.-Ing. W. Richter  
Responsible for test section



GmbH  
Im Teelbruch 116  
45219 Essen  
Tel.: + 49 (0) 20 54 / 95 19 - 0  
Fax: + 49 (0) 20 54 / 95 19 - 397

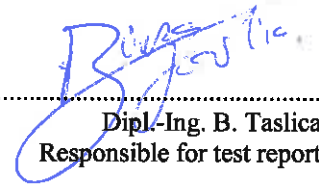

.....  
Dipl.-Ing. B. Taslica  
Responsible for test report

## 2. Administrative Data

### 2.1. Identification of the testing laboratory

Company name:	CETECOM GmbH
Address:	Im Teelbruch 116 45219 Essen - Kettwig Germany
Responsible for testing laboratory:	Dipl.-Ing. W. Richter
Deputy:	Dipl.-Ing. J. Schmitt
Laboratory accreditations/Listings:	DAkkS-Registration No. D-PL-12047-01-01 FCC-Registration No.: 736496, MRA US-EU 0003 IC-Registration No. 3462D-1, 3462D-2, 3462D-3 VCCI Reg. No. R-2665, R-2666, C-2914, T-1967, G-301

### 2.2. Test location

#### 2.2.1. Test laboratory “CTC”

Company name:	see chapter 2.1. Identification of the testing laboratory
---------------	---

### 2.3. Organizational items

Order No.:	2-0023-11-1
Responsible for test report and project leader:	Dipl.-Ing. B. Taslica
Receipt of EUT:	2011-08-29
Date(s) of test:	2011-08-29 to 2011-09-30
Date of report:	2011-10-10
-----	
Version of template:	11.05 _All.Dotm

### 2.4. Applicant’s details

Applicant’s name:	Research In Motion Limited
Address:	440 Phillip Street N2L 5R9 Waterloo ON  CANADA
Contact person:	Mr. Masud Attayi

### 2.5. Manufacturer’s details

Manufacturer’s name:	Research In Motion Limited
Address:	295 Phillip Street N2L 3W8 Waterloo ON  CANADA

### 3. Equipment under test (EUT)

#### 3.1. Additional declaration and description of main EUT

Main function	Mobile phone with integrated IEEE802.11b/g/n W-LAN Transceiver		
Type	REA71UW		
Frequency range (US/Canada -bands)	2412 MHz (Channel 1) to 2462 MHz (Channel 11)		
Type of modulation	See chapter 3.2		
Number of channels (USA/Canada -bands)	1 to 11		
Antenna Type	Integrated		
Antenna Gain	Max. -0.42 (2412MHz)/0.58(2437MHz)/0.71(2484MHz) dBi PK gain according applicants information in 2.4GHz band		
MAX Field strength (radiated):	102.43 dB $\mu$ V/m@3m distance and 2441 MHz		
FCC-ID	L6AREA70UW		
IC-ID	2503-REA70UW		
Installed option	<input checked="" type="checkbox"/> GSM Bands <input checked="" type="checkbox"/> W-CDMA Band II and Band V <input checked="" type="checkbox"/> Bluetooth <sup>®</sup> <input checked="" type="checkbox"/> battery charging option <input checked="" type="checkbox"/> GPS (not tested within this test report) <input checked="" type="checkbox"/> NFC technology		
EUT sample type	<input type="checkbox"/> Production	<input checked="" type="checkbox"/> Pre-Production	<input type="checkbox"/> Engineering

### 3.2. IEEE 802.11 Overview: Modulation and Data Rates

The modulations and data rates defined for 802.11 b/g/n transmitters are identified in the table below. Also it shows which operational mode is possible for the device under test (EUT).

802.11b-Mode (DSSS System)		
Data rate [MBps]	Modulation type	Supported by EUT
1	DBPSK (Differential binary phase shift keying)	YES
2	DQPSK (Differential quadrature phase shift keying)	YES
5.5	CCK/PBCC (8-chip complementary code keying)	YES
11		
22	ERP-PBCC (Packet binary convolutional coding)	YES

802.11g-Mode (OFDM system)		
Brutto data rate [MBps]	Modulation type of subcarriers	Supported by EUT
6	BPSK	YES
9		
12		
18	QPSK	YES
24		
36		
48	64-QAM	YES
54		

Remark: 52 sub-carriers which can be modulated at different data-rates.

802.11n-Mode (OFDM)		
Brutto data rate [MBps]	Modulation type	Supported by EUT
7.2/14.4/21.7/28.9/43.3/57.8/65/72.2 Mbps	HT20 (MCS0..MCS7)	Yes
14.444/28.889/43.333/57.778/86.667/115.556/130/144.444 Mbps	HT20 (MCS8..MCS15)	No
15/30/45/60/90/120/135/150 Mbps	HT40 (MCS0..MCS7)	Yes
30/60/90/120/180/240/270/300 Mbps	HT40 (MCS8..MCS15)	No

### 3.3. EUT: Type, S/N etc. and short descriptions used in this test report

Short description*)	EUT	Type	S/N serial number	HW hardware status	SW software status
EUT A	Smartphone	REA71UW	004401138459 314	CER-41251-001 rev. 2	v7.0.0.368 PL: 9.32.0.13 Bundle: 1755
EUT B	Smartphone	REA71UW	004401138459 470	CER-41251-001 rev. 2	v7.0.0.368 PL: 9.32.0.13 Bundle: 1755
EUT C	Standard Stereo Headset (Hoisdén)	HDW-24529-001	--	--	--
EUT D	Worldwide Captive Cable Charger (750mA)	HDW-17957-003	--	--	--
EUT E	Li-Ion Battery (1230mAh)	BAT-30615-006	--	JM1	--

\*) EUT short description is used to simplify the identification of the EUT in this test report.

### 3.4. Auxiliary Equipment (AE): Type, S/N etc. and short descriptions

AE short description *)	Auxiliary Equipment	Type	S/N serial number	HW hardware status	SW software status
AE 1	802.11 b/g/n Access-Point	D-Link DAP2553	CTC#2	--	--
AE 2	Dummy battery	For EUT A	--	--	--

\*) AE short description is used to simplify the identification of the auxiliary equipment in this test report.



### 3.5. EUT set-ups

EUT set-up no. *)	Combination of EUT and AE	Remarks
Set. 1	EUT A + AE 2	Used for RF conducted measurements.
Set. 2	EUT B + EUT E	Used for RF radiated measurements. EUT battery powered
Set. 3	EUT A + EUT C + EUT D + EUT E +AE 1	Used for conducted measurements (AC-mains emission measurement) and for radiated measurements when operation of RX-mode. AE1 is used as master.

\*) EUT set-up no. is used to simplify the identification of the EUT set-up in this test report.

### 3.6. EUT operating modes

EUT operating mode no. *)	Description of operating modes	Additional information
op. 1	WLAN TX-Test Mode	The EUT was put to transmissions mode with help of a special firmware software. The modulation and Bit rate used will be special mentioned in the results.
op. 2	WLAN Continuous TX-Test Mode	The EUT was put to continuous 100% transmissions mode with help of a special firmware software (unmodulated).
op. 3	WLAN Continuous Test RX-Mode	The EUT was put to receiver mode only with help of a special firmware software.
op. 4	WLAN TX Traffic link	A traffic link as slave was established to an master access-point. The settings were set from the web-control page of the access-point.
op. 5	Charging battery	Charging standard battery. This operating mode is combined with other op. modes.

\*) EUT operating mode no. is used to simplify the test report.

## 4. DESCRIPTION OF TEST SET-UP'S

### 4.1. Test Set-up for conducted measurements

EUT's RF-signal is first attenuated by 20dB before it is feed to the spectrum analyzer. Customers RF-adapters are used in case of no suitable RF-Adapters are mounted on the EUT. The specific attenuation losses for the RF-signal path is determined within a path-loss calibration and the measurement readings corrected therefore. The Test-PC as shown above was not necessary for this project.

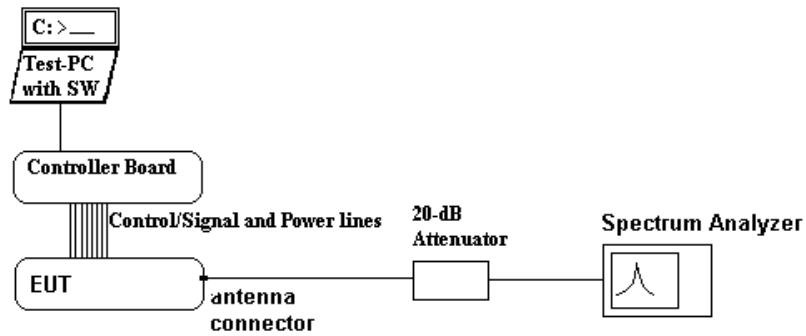

Schematic: Test set-up 3: conducted for RF-tests

## 4.2. Test set-up for radiated measurements

Please see below description and schematic for radiated measurements used set-up.

### MEASUREMENT METHOD (30 MHz <math>f < 1\text{ GHz}</math>):

A EMI analyzer together with a broadband antenna was used in order to identify the emissions from the EUT by positioning the antenna close to the EUT surfaces.

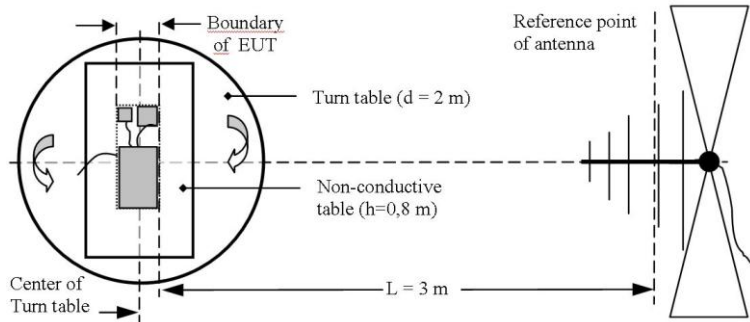

The interconnecting cables and equipment position were varied in order to maximize the emissions. Then most critical frequencies are recorded for further investigations. Based on the exploratory measurements, the most critical frequencies are re-measured by maintaining the EUT's operating mode, cable position, etc. The EUT was placed on a non-conductive support of 0.8 m height. By rotating the turntable angle in

the range 0 to 360 degree, the EUT itself either over 3-orthogonal axis (not defined usage position) or 2-orthogonal axis (defined usage position) and the measurement antenna height from 1 meter to 4 meters, the maximized emissions are recorded. The measurements are performed for both polarizations of the measuring antenna: horizontal and vertical.

### MEASUREMENT METHOD (1 GHz <math>f < 26.5\text{ GHz}</math>):

The EUT and accessories are placed on a non-conducting tipping table of 0.8 meter height (semi-anechoic chamber) or 1.55m height (fully-anechoic chamber) which is situated in the middle of the turntable. The turntable can rotate the device under test 360 degree, the tipping table can rotate the device from laid to standing position. This way the device under test can be rotated in all three orthogonal planes in order to maximize the detected emissions. The turn- and tipping table are controlled by a controller unit. All positions manipulations are software controlled from a operator PC.

The measurements are performed for both receiving antenna polarisations: vertical and horizontal.

Up to 18 GHz a measurement distance of 3 meters is used, above 18 GHz the distance is 1 meter. A biconical-logarithmic antenna up to 1 GHz and a logarithmic-periodic antenna for frequencies above 1 GHz up to 26.5 GHz is used. For frequencies above 26.5 GHz a horn antenna is used, pls. compare the equipment list for more details.

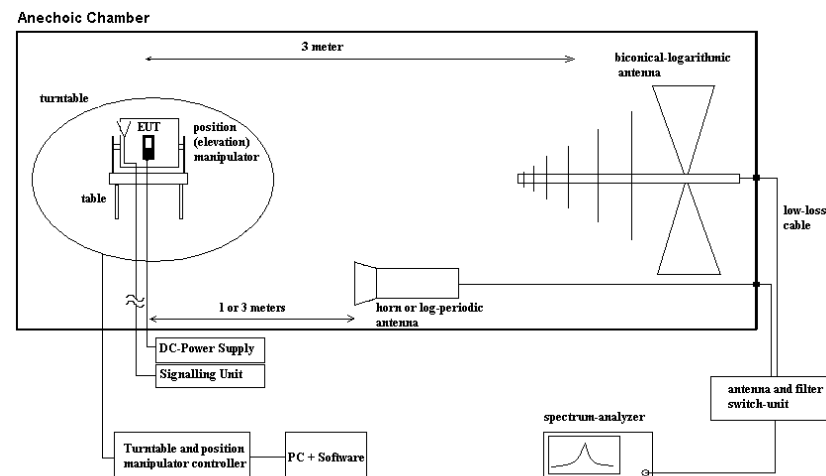

The EUT is powered either by a external DC-supply with nominal voltage or a AC/DC power supply as accessory. The communication signalling (if necessary for operation) is performed from outside the chamber with a communication test simulator (CMU200 from Rohde&Schwarz) and a signalling antenna place near the EUT.

### Schematic: radiated measurements test set-up

## 5. Measurements

### 5.1. 6 dB Bandwidth

**TEST LOCATION AND EQUIPMENT (for reference numbers please see chapter 'List of test equipment')**

test location	<input checked="" type="checkbox"/> CETECOM Essen (Chapter. 2.2.1)	<input type="checkbox"/> Please see Chapter. 2.2.2	<input type="checkbox"/> Please see Chapter. 2.2.3
test site	<input type="checkbox"/> 441 EMI SAR	<input type="checkbox"/> 487 SAR NSA	<input type="checkbox"/> 337 OATS
receiver	<input type="checkbox"/> 377 ESCS30	<input type="checkbox"/> 001 ESS	<input checked="" type="checkbox"/> 489 ESU
otherwise	<input checked="" type="checkbox"/> 613 20dB Attenuator	<input checked="" type="checkbox"/> cable K4	

**REFERENCES: §15.247(a)(1), RSS-210: A8.1(b)**

(1) *Frequency hopping systems shall have hopping channel carrier frequencies separated by a minimum of 25 kHz or the 20 dB bandwidth of the hopping channel, whichever is greater. Alternatively, frequency hopping systems operating in the 2400-2483.5 MHz band may have hopping channel carrier frequencies that are separated by 25 kHz or two-thirds of the 20 dB bandwidth of the hopping channel, whichever is greater, provided the systems operate with an output power no greater than 125 mW.*

(2) *DSSS Systems using digital modulation techniques may operate in the 902-928 MHz, 2400-2483.5 MHz, and 5725-5850 MHz bands. The minimum 6 dB bandwidth shall be at least 500 kHz.*

**EUT SETTINGS:**

The EUT was instructed to send with maximum power (if adjustable) according applicants instructions. Different modulation characteristics have been checked, e.g. data rates which EUT can operate.

**MEASUREMENT METHOD:**

The measurement was performed with the RBW set to 100kHz. The span was set to cover the complete carrier. Three carrier frequencies (low/middle/high) were used for showing the compliance with this requirement. A DELTA Marker method was set to measure the bandwidth compared to the highest In-Band power. The operating modes have been varied (e.g. data rate, modulation scheme, etc.). If applicable the hopping-mode is switched off.

Also the **99% emission bandwidth** was measured. Two markers are placed on frequency points such that left to lower f-marker and right to higher f-marker only 1% of the TX-power is contained. Between the markers, 99% of the power is laying. The RBW value is readjusted and the measurement repeated until the RBW/EBW ratio is around 1%.

**SPECTRUM-ANALYZER SETTINGS:**

Span	Set as to fully display the emissions and at least 20dB below the PEAK level
Resolution Bandwidth (RBW)	Set to approx 1% of the emission width
Video Bandwidth (VBW)	3 times the resolution bandwidth
Sweep time	Coupled and low enough to have no gaps within power envelope
Detector	Sample (if bin width: Span/no. of frequency points SA < 0.5*RBW SA otherwise Peak detector)
Sweep mode	Repetitive Mode, MAX-HOLD

**RESULTS:**

**6dB BANDWIDTH:**

Set-up no.: 1 Op. Mode: 1	6dB BANDWIDTH [MHz]		
T <sub>NOM</sub> =21°C, V <sub>NOM</sub> = 3V	Low channel = 1 (2412 MHz)	Middle channel = 6 (2437 MHz)	High channel = 11 (2462 MHz)
Maximum value for CCK/PBCC Modulation (b-Mode)	10.54	10.32	<b>10.57</b>
Maximum value for BPSK Modulation (g-mode)	16.31	<b>16.44</b>	16.35
Maximum value for OFDM Modulation (n-Mode)	17.56	17.50	<b>17.60<sup>2.)</sup></b>

**Remark:** 1.) see extract of diagrams and results for different modulation types(Data rates) in separate document A1  
 2.) maximum 6dB value

Additional also the 99% occupied bandwidth were measured for worst-case 6dB bandwidth.

**99% OCCUPIED BANDWIDTH:**

Set-up no.: 1 Op. Mode: 1	99% Bandwidth [MHz]		
T <sub>NOM</sub> =21°C, V <sub>NOM</sub> = 3V	Low channel = 1 (2412 MHz)	Middle channel = 6 (2437 MHz)	High channel = 11 (2462 MHz)
Maximum value for CCK/PBCC Modulation 11MBps	--	--	14.448
Maximum value for BPSK Modulation 24MBps	--	16.402	--
Maximum value for MCS7	--	--	<b>17.508<sup>2.)</sup></b>

**Remark:** 1.) maximum 99% occupied bandwidth value

**VERDICT:** pass

## 5.2. 20dBc Emission specification

### TEST LOCATION AND EQUIPMENT (for reference numbers please see chapter 'List of test equipment')

test location	<input checked="" type="checkbox"/> CETECOM Essen (Chapter. 2.2.1)	<input type="checkbox"/> Please see Chapter. 2.2.2	<input type="checkbox"/> Please see Chapter. 2.2.3
test site	<input type="checkbox"/> 441 EMI SAR	<input type="checkbox"/> 487 SAR NSA	<input type="checkbox"/> 337 OATS
receiver	<input type="checkbox"/> 377 ESCS30	<input type="checkbox"/> 001 ESS	<input checked="" type="checkbox"/> 489 ESU
spectr. analys.	<input type="checkbox"/> 489 ESU	<input type="checkbox"/> 120 FSEM	<input type="checkbox"/> 264 FSEK
power supply	<input type="checkbox"/> 456 EA 3013A	<input type="checkbox"/> 457 EA 3013A	<input type="checkbox"/> 459 EA 2032-50
otherwise	<input checked="" type="checkbox"/> 613 20dB Attenuator	<input checked="" type="checkbox"/> cable K4	

### REFERENCES: §15.247, §15.205, RSS-210: A8.5

(d) In any 100 kHz bandwidth outside the frequency band in which the spread spectrum or digitally modulated intentional radiator is operating, the radio frequency power that is produced by the intentional radiator shall be at least 20 dB below that in the 100 kHz bandwidth within the band that contains the highest level of the desired power, based on either an RF conducted or a radiated measurement, provided the transmitter demonstrates compliance with the peak conducted power limits.

### EUT SETTINGS:

The EUT was instructed to send with maximum power (if adjustable) according applicants instructions.

### MEASUREMENT METHOD:

The frequency spectrum was investigated for **conducted** spurious emissions values lower than 20dB related to the RF-carrier power value. Three carrier frequencies (low/middle/high channel) were used for showing the compliance with this requirement. The detector were chosen according §15.209(d). The video bandwidth (VBW) was chosen 10 times the resolution bandwidth (RBW). The frequency scan was up to 10 times the highest channel frequency within the operational mode. The spectrum-analyzer was set to MAX-PEAK Detector, MAX-Hold Mode.

The EUT was instructed to send with maximum power (if adjustable) according applicants instructions.

### b-Mode, 1Mbps

Set-up no.: 1 Op. Mode: 1	RF-CONDUCTED TEST: 20 dBc SPURIOUS EMISSIONS					
	Low channel =1 (2412 MHz)		Middle channel = 6 (2439 MHz)		High channel = 11 (2462 MHz)	
	Level Reference (In-Band) = 7.17 dBm (-> Limit: -12.83dBm)		Level Reference (In-Band) = 7.51 dBm (-> Limit: -12.49dBm)		Level Reference (In-Band) = 7.63 dBm (-> Limit: -12.37dBm)	
Frequency Range	Frequency [MHz]	Value [dBc]	Frequency [MHz]	Value [dBc]	Frequency [MHz]	Value [dBc]
150kHz ..30MHz	3.02	40.64	3.03	41.96	2.97	41.61
30 .. 1000 MHz	987.18	42.07	855.79	42.35	Noise level	>42.65
1 GHz .. 2.8 GHz	2598.0	40.94	2670.19	41.04	2332.69	41.05
2.8 GHz ..18 GHz	17585	54.86	4870.51	54.86	16885	54.92
18..25GHz	21436.87	54.41	Noise level	>22.01	Noise level	>65.31
Band-Edge	--	42.77	--	--	--	43.86

**Remark:** see diagrams in separate document A1

The limit on the diagrams is 20dB under the reference level measured In-Band for each channel

**b-Mode, 5.5Mbps**

Set-up no.: 1 Op. Mode: 1	RF-CONDUCTED TEST: 20 dBc SPURIOUS EMISSIONS					
Frequency Range	Low channel =1 (2412 MHz)		Middle channel = 6 (2439 MHz)		High channel = 11 (2462 MHz)	
	Level Reference (In-Band) = 6.85 dBm (-> Limit: -13.15dBm)		Level Reference (In-Band) = 7.96 dBm (-> Limit: -12.04 dBm)		Level Reference (In-Band) = 7.20 dBm (-> Limit: -12.08dBm)	
	Frequency [MHz]	Value [dBc]	Frequency [MHz]	Value [dBc]	Frequency [MHz]	Value [dBc]
150kHz ..30MHz	2.97	42.67	3.02	41.72	7.99	42.57
30 .. 1000 MHz	841.36	41.62	919.88	42.51	Noise level	>42.92
1 GHz .. 2.8 GHz	2303.84	40.49	2266.34	42.14	2113.46	40.99
2.8 GHz ..18 GHz	16221	48.44	16757	49.84	16660	49.67
18..25GHz	23608	48.11	Noise level	>50.1	23631	49.84
Band-Edge	--	41.85	--	--	--	43.05

**Remark:** see diagrams in separate document A1

The limit on the diagrams is 20dB under the reference level measured In-Band for each channel

**b-Mode, 11Mbps**

Set-up no.: 1 Op. Mode: 1	RF-CONDUCTED TEST: 20 dBc SPURIOUS EMISSIONS					
Frequency Range	Low channel =1 (2412 MHz)		Middle channel = 6 (2439 MHz)		High channel = 11 (2462 MHz)	
	Level Reference (In-Band) = 6.30 dBm (-> Limit: -13.70dBm)		Level Reference (In-Band) = 7.29 dBm (-> Limit: -12.08dBm)		Level Reference (In-Band) = 7.12 dBm (-> Limit: -12.88dBm)	
	Frequency [MHz]	Value [dBc]	Frequency [MHz]	Value [dBc]	Frequency [MHz]	Value [dBc]
150kHz ..30MHz	3.02	41.36	2.95	42.96	7.99	42.57
30 .. 1000 MHz	580.19	41.09	48.21	42.72	578.58	42.06
1 GHz .. 2.8 GHz	2667.30	40.21	2352.88	42.24	2396.1	41.3
2.8 GHz ..18 GHz	17805.12	47.33	4870.51	46.9	11812	49.56
18..25GHz	20426	44.1	24237	48.6	Noise level	>45.5
Band-Edge	--	41.54	--	--	--	43.37

**Remark:** see diagrams in separate document A1

The limit on the diagrams is 20dB under the reference level measured In-Band for each channel

**g-Mode, 6Mbps**

Set-up no.: 1 Op. Mode: 1	RF-CONDUCTED TEST: 20 dBc SPURIOUS EMISSIONS					
Frequency Range	Low channel =1 (2412 MHz)		Middle channel = 6 (2439 MHz)		High channel = 11 (2462 MHz)	
	Level Reference (In-Band) = 3.94 dBm (-> Limit: -16.06 dBm)		Level Reference (In-Band) = 5.88 dBm (-> Limit: -14.12 dBm)		Level Reference (In-Band) = 3.86 dBm (-> Limit: -16.14 dBm)	
	Frequency [MHz]	Value [dBc]	Frequency [MHz]	Value [dBc]	Frequency [MHz]	Value [dBc]
150kHz ..30MHz	3.1	39.14	5.92	40.95	22.52	40.17
30 .. 1000 MHz	950.32	38.88	889.43	40.9	951.93	38.68
1 GHz .. 2.8 GHz	2733.6	37.78	2497.11	40.19	2727.88	37.26
2.8 GHz ..18 GHz	13956	45.75	15515.38	48.09	16830.76	25.09
18..25GHz	24652	43.69	21858	47.93	Noise level	>42.3
Band-Edge	--	-30.29	--	--	--	38.37

**Remark:** see diagrams in separate document A1

The limit on the diagrams is 20dB under the reference level measured In-Band for each channel

**g-Mode, 24Mbps**

Set-up no.: 1 Op. Mode: 1	RF-CONDUCTED TEST: 20 dBc SPURIOUS EMISSIONS					
Frequency Range	Low channel =1 (2412 MHz)		Middle channel = 6 (2439 MHz)		High channel = 11 (2462 MHz)	
	Level Reference (In-Band) = 3.69 dBm (-> Limit: -16.31 dBm)		Level Reference (In-Band) = 4.08 dBm (-> Limit: -15.92 dBm)		Level Reference (In-Band) = 3.57 dBm (-> Limit: -16.43 dBm)	
	Frequency [MHz]	Value [dBc]	Frequency [MHz]	Value [dBc]	Frequency [MHz]	Value [dBc]
150kHz ..30MHz	14.82	40.25	21.08	40.4	19.65	40.15
30 .. 1000 MHz	584.99	27.8	746.83	38.6	504.88	38.02
1 GHz .. 2.8 GHz	2736.53	27.51	2719.23	37.88	2615.38	37.63
2.8 GHz ..18 GHz	Noise Level	45.88	11715.38	45.8	Noise Level	>40.94
18..25GHz	23866.98	42.96	Noise level	>44.67	Noise level	>40.67
Band-Edge	--	31.31	--	--	--	40.44

**Remark:** see diagrams in separate document A1

The limit on the diagrams is 20dB under the reference level measured In-Band for each channel



**g-Mode, 54Mbps**

Set-up no.: 1 Op. Mode: 1	RF-CONDUCTED TEST: 20 dBc SPURIOUS EMISSIONS					
Frequency Range	Low channel =1 (2412 MHz)		Middle channel = 6 (2439 MHz)		High channel = 11 (2462 MHz)	
	Level Reference (In-Band) = 2.73 dBm (-> Limit: -17.27dBm)		Level Reference (In-Band) = 3.07 dBm (-> Limit: -16.93 dBm)		Level Reference (In-Band) = 3.17 dBm (-> Limit: -16.83dBm)	
	Frequency [MHz]	Value [dBc]	Frequency [MHz]	Value [dBc]	Frequency [MHz]	Value [dBc]
150kHz ..30MHz	5.01	38.7	18.17	38.59	13.72	40.0
30 .. 1000 MHz	701.96	37.66	847.77	38.35	750.03	37.34
1 GHz .. 2.8 GHz	2373.07	36.1	2681.73	37.0	2335.5	37.23
2.8 GHz ..18 GHz	6545.69	40.24	6912.22	40.6	Noise Level	>41.12
18..25GHz	20903.80	39.36	24915.8	40.58	21128.25	40.61
Band-Edge	--	32.87	--	--	--	40.54

**Remark:** see diagrams in separate document A1

The limit on the diagrams is 20dB under the reference level measured In-Band for each channel

**n-Mode, MCS0**

Set-up no.: 1 Op. Mode: 1	RF-CONDUCTED TEST: 20 dBc SPURIOUS EMISSIONS					
Frequency Range	Low channel =1 (2412 MHz)		Middle channel = 6 (2439 MHz)		High channel = 11 (2462 MHz)	
	Level Reference (In-Band) = 3.87 dBm (-> Limit: -16.13 dBm)		Level Reference (In-Band) = 5.76 dBm (-> Limit: -14.24 dBm)		Level Reference (In-Band) = 3.84 dBm (-> Limit: -16.16 dBm)	
	Frequency [MHz]	Value [dBc]	Frequency [MHz]	Value [dBc]	Frequency [MHz]	Value [dBc]
150kHz ..30MHz	6.25	39.94	11.76	41.62	4.20	39.44
30 .. 1000 MHz	923.08	38.69	987.18	40.89	541.73	38.73
1 GHz .. 2.8 GHz	2528.84	37.89	2537.5	39.76	2569.23	37.82
2.8 GHz ..18 GHz	Noise Level	41.41	Noise Level	>43.1	Noise Level	>41.83
18..25GHz	24060.1	41.97	21100.2	42.7	21156.3	42.14
Band-Edge	--	26.09	--	--	--	38.87

**Remark:** see diagrams in separate document A1

The limit on the diagrams is 20dB under the reference level measured In-Band for each channel

**n-Mode, MCS4**

Set-up no.: 1 Op. Mode: 1	RF-CONDUCTED TEST: 20 dBc SPURIOUS EMISSIONS					
Frequency Range	Low channel =1 (2412 MHz)		Middle channel = 6 (2439 MHz)		High channel = 11 (2462 MHz)	
	Level Reference (In-Band) = 3.72 dBm (-> Limit: -16.28 dBm)		Level Reference (In-Band) = 3.91 dBm (-> Limit: -16.09 dBm)		Level Reference (In-Band) = 3.65 dBm (-> Limit: -16.35 dBm)	
	Frequency [MHz]	Value [dBc]	Frequency [MHz]	Value [dBc]	Frequency [MHz]	Value [dBc]
150kHz ..30MHz	9.99	39.79	6.88	40.39	13.24	40.41
30 .. 1000 MHz	855.79	38.68	857.39	38.87	722.79	38.64
1 GHz .. 2.8 GHz	2629.8	37.14	2018.2	36.68	2606.73	37.42
2.8 GHz ..18 GHz	Noise Level	40.88	Noise Level	>41.72	6942.6	40.74
18..25GHz	21128.25	41.8	Noise Level	42.05	24368.73	19.83
Band-Edge	--	31.59	--	--	--	40.67

**Remark:** see diagrams in separate document A1

The limit on the diagrams is 20dB under the reference level measured In-Band for each channel

**n-Mode, MCS7**

Set-up no.: 1 Op. Mode: 1	RF-CONDUCTED TEST: 20 dBc SPURIOUS EMISSIONS					
Frequency Range	Low channel =1 (2412 MHz)		Middle channel = 6 (2439 MHz)		High channel = 11 (2462 MHz)	
	Level Reference (In-Band) = 1.69 dBm (-> Limit: -18.31 dBm)		Level Reference (In-Band) = 2.13 dBm (-> Limit: - 17.87 dBm)		Level Reference (In-Band) = 2.30dBm (-> Limit: -17.7 dBm)	
	Frequency [MHz]	Value [dBc]	Frequency [MHz]	Value [dBc]	Frequency [MHz]	Value [dBc]
150kHz ..30MHz	25.68	38.3	16.49	39.02	18.94	29.13
30 .. 1000 MHz	850.98	37.0	709.97	37.01	870.21	37.64
1 GHz .. 2.8 GHz	2373.0	35.29	2381.73	35.35	2171.15	36.03
2.8 GHz ..18 GHz	6881.76	39.49	Noise Level	39.67	15959.11	40.04
18..25GHz	18434.8	49.13	21591.18	40.06	24551.1	39.82
Band-Edge	--	33.29	--	--	--	38.81

**Remark:** see diagrams in separate document A1

The limit on the diagrams is 20dB under the reference level measured In-Band for each channel

**VERDICT:** pass

### 5.3. Power specification

#### TEST LOCATION AND EQUIPMENT (for reference numbers please see chapter 'List of test equipment')

test location	<input checked="" type="checkbox"/> CETECOM Essen (Chapter. 2.2.1)	<input checked="" type="checkbox"/> 443 System CTC-FAR-EMI-	<input type="checkbox"/> Please see Chapter. 2.2.3
test site	<input type="checkbox"/> 441 EMI SAR	<input type="checkbox"/> 487 SAR NSA	<input type="checkbox"/> 337 OATS
receiver	<input type="checkbox"/> 377 ESCS30	<input type="checkbox"/> 001 ESS	<input checked="" type="checkbox"/> 489 ESU
spectr. analys.	<input type="checkbox"/> 489 ESU	<input type="checkbox"/> 120 FSEM	<input type="checkbox"/> 264 FSEK
power supply	<input type="checkbox"/> 456 EA 3013A	<input type="checkbox"/> 457 EA 3013A	<input type="checkbox"/> 459 EA 2032-50
otherwise	<input checked="" type="checkbox"/> 613 20dB Attenuator	<input checked="" type="checkbox"/> cable K4	<input type="checkbox"/> 268 EA- 3050
			<input type="checkbox"/> 494 AG6632A
			<input type="checkbox"/> 498 NGPE 40

#### REFERENCE: §15.247(B)(1) AND RSS-210: A8.4 (2)

The maximum peak conducted output power of the intentional radiator shall not exceed the following:

(1) For frequency hopping systems (FHHS) operating in the 2400-2483.5 MHz band employing at least 75 non-overlapping hopping channels, and all frequency hopping systems in the 5725-5850 MHz band: 1 watt. For all other frequency hopping systems in the 2400-2483.5 MHz band: 0.125 watts.

(2) For frequency hopping systems operating in the 902-928 MHz band: 1 watt for systems employing at least 50 hopping channels; and, 0.25 watts for systems employing less than 50 hopping channels, but at least 25 hopping channels, as permitted under paragraph (a)(1)(i) of this section.

(3) For systems using digital modulation (DSSS) in the 902-928 MHz, 2400-2483.5 MHz, and 5725-5850 MHz bands: 1 Watt. As an alternative to a peak power measurement, compliance with the one Watt limit can be based on a measurement of the maximum conducted output power. Maximum Conducted Output Power is defined as the total transmit power delivered to all antennas and antenna elements averaged across all symbols in the signalling alphabet when the transmitter is operating at its maximum power control level. Power must be summed across all antennas and antenna elements. The average must not include any time intervals during which the transmitter is off or is transmitting at a reduced power level. If multiple modes of operation are possible (e.g., alternative modulation methods), the maximum conducted output power is the highest total transmit power occurring in any mode.

(4) The conducted output power limit specified in paragraph (b) of this section is based on the use of antennas with directional gains that do not exceed 6 dBi. Except as shown in paragraph (c) of this section, if transmitting antennas of directional gain greater than 6 dBi are used, the conducted output power from the intentional radiator shall be reduced below the stated values in paragraphs (b)(1), (b)(2), and (b)(3) of this section, as appropriate, by the amount in dB that the directional gain of the antenna exceeds 6 dBi.

#### ANTENNA CHARACTERISTICS:

- Directional Gain < 6 dBi (measured: difference between measured conducted and radiated eirp. power)
- Directional Gain > 6 dBi (measured / applicant's declaration) -> conducted power reduction necessary

#### EUT SETTINGS:

For FHHS-systems hopping mode was switched-off so fixed three different channels could be measured. The EUT was instructed to send with maximum power (if adjustable) according applicants instructions. Different modulation characteristics have been checked, e.g. data rates which EUT can operate.

#### MEASUREMENT METHOD:

The measurement was performed in non-hopping transmission mode with the carrier set to lowest/middle and highest channel. The power was also checked for different data rates, modulation scheme or packet types if applicable.

**SETTINGS ON SPECTRUM-ANALYZER:**

Center Frequency	Nominal channel frequency
Span	150 MHz
Resolution Bandwidth (RBW)	50 MHz > 6dB-bandwidth of the signal, ANSI 63.10: 2009, chapter 6.10.2.1a
Sweep time	coupled
Detector	Peak, Max hold mode
Sweep Mode	Repetitive mode

**5.3.1. CONDUCTED MEASUREMENT: MAX. PEAK POWER**

- Maximum declared antenna gain [isotropical]: 0.71 dBi for Channel 11 (2462MHz)
- External Path Loss: 20.9 dB -> set as correction in spectrum-analyzer

**RESULTS**

Different modulation types and data rates were tested in order to find the maximum peak conducted output power. **Enclosed are only the maximum values for each modulation format**, pls. compare separate document A1 for all results.

MAX PEAK POWER (conducted) [dBm]			
Set-up no.: 1 Op-Mode: 1	Low channel = 1 (2412 MHz)	Middle channel = 6 (2437 MHz)	High channel = 11 (2462 MHz)
IEEE 802.11 b-Mode: 1 Mbit	--	--	18.39
IEEE 802.11 g-Mode: 54 MBps	--	21.80	--
IEEE 802.11 n-mode: MCS4	--	<b>22.09</b> <sup>2.)</sup>	--
Limit	1 Watt (30dBm) Peak		

Remark:

- 1.) at this place only each maximum power reported, pls. compare separate annex A1 for more details
- 2.) maximum value among all data rates and modulations, pls. compare separate annex A1 for more details

**VERDICT:** Maximum value of 22.09 dBm Peak (161.81 mW) -> passed

**5.3.2. RADIATED MEASUREMENT: MAX. E.I.R.P POWER**

**Test location and equipment** (for reference numbers please see chapter 'List of test equipment')

test site	<input type="checkbox"/> 441 EMI SAR	<input type="checkbox"/> 348 EMI cond.	<input checked="" type="checkbox"/> 443 EMI FAR	<input type="checkbox"/> 347 Radio.lab.	<input type="checkbox"/> 337 OATS	<input type="checkbox"/>
equipment	<input type="checkbox"/> 331 HC 4055	<input type="checkbox"/>	<input type="checkbox"/>	<input type="checkbox"/>	<input type="checkbox"/>	<input type="checkbox"/>
Spectr. analys.	<input type="checkbox"/> 489 ESU	<input type="checkbox"/> 120 FSEM	<input type="checkbox"/> 264 FSEK	<input checked="" type="checkbox"/> 489 ESU	<input type="checkbox"/>	<input type="checkbox"/>
antenna meas	<input checked="" type="checkbox"/> 549 HL025	<input type="checkbox"/> 289 CBL 6141	<input type="checkbox"/> 439 HL 562	<input type="checkbox"/> 133 EMCO3115	<input type="checkbox"/> 302 BBHA9170	<input type="checkbox"/> 477 GPS
antenna subst	<input type="checkbox"/> 071 HUF-Z2	<input type="checkbox"/> 020 EMCO3115	<input type="checkbox"/> 063 LP 3146	<input type="checkbox"/> 303 BBHA9170	<input type="checkbox"/>	<input type="checkbox"/>
power meter	<input type="checkbox"/> 009 NRV	<input type="checkbox"/> 010 URV5-Z2	<input type="checkbox"/> 011 URV5-Z2	<input type="checkbox"/>	<input type="checkbox"/>	<input type="checkbox"/>
Signalgener.	<input type="checkbox"/> 008 SMG	<input type="checkbox"/> 140 SMHU	<input type="checkbox"/> 263 SMP04	<input type="checkbox"/>	<input type="checkbox"/>	<input type="checkbox"/>
power meter	<input type="checkbox"/> 262 NRV-S	<input type="checkbox"/> 266 NRV-Z31	<input type="checkbox"/> 265 NRV-Z33	<input type="checkbox"/> 261 NRV-Z55	<input type="checkbox"/> 356 NRV-Z1	<input type="checkbox"/>
DCpower	<input type="checkbox"/> 086 LNG50-10	<input type="checkbox"/> 087 EA3013	<input type="checkbox"/> 354 NGPE 40	<input type="checkbox"/> 349 car battery	<input type="checkbox"/> 350 Car battery	<input type="checkbox"/>

**EUT SETTINGS:**

For FHHS-systems hopping mode was switched-off so fixed three different channels could be measured. The EUT was instructed to send with maximum power (if adjustable) according applicants instructions. Different modulation characteristics have been checked, e.g. data rates which EUT can operate.

**MEASURING METHOD 1:** The method is according ANSI/TIA/EIA-603-C-2004 and consist of two steps.

**First step:** The maximum power was recorded by turning the EUT continuously 360 degree steps, the EUT in horizontal (laying) and vertical (standing) position. Measurements have been performed with the measurement antenna set to horizontal and vertical polarisation. The spectrum analyzer was set to MAX-PEAK Detector, MAX-Hold Mode. The RBW used was bigger than the 20-dB bandwidth of the EUT and set to 3 MHz. VBW set to 10MHz with coupled sweep time. The maximum trace peak value was recorded.

**Second step:** a horn antenna was set instead of the EUT and connected to the signal generator. The level was adjusted such as the same level as in step 1 could be reached. The conducted power delivered to the antenna was measured and the value corrected with the known antenna eirp gain.

**Measurement method:** a field strength measurement was performed in 3m distance to the EUT. General measurement procedures as shown in chapter 5.3 applies therefore. Using transformation formula between field strength and e.i.r.p. power as shown in ANSI63.10: 2009, chapter 7.8.2 is used for conversion. In addition a bandwidth correction factor applied:  $10 \cdot \log(6\text{dB BW/RBW}=1\text{MHz})$

**MAX. FIELD STRENGTH MEASURED IN 3m DISTANCE**

**b-MODE**

Maximum Radiated field strength@3m distance			
Set-up no.: 2 Op. Mode: 1	Low channel = 1 (2412 MHz)	Middle channel = 7 (2441 MHz)	High channel = 11 (2462 MHz)
Determined field strength [dBuV/m] in 3m distance with RBW=1MHz	100.08 (PK) 96.63 (AV)	89.74 (PK) 85.81 (AV)	91.05 (PK) 86.99 (AV)
Value in dBm using conversion formula and assumed numeric Gain=1: $E = \sqrt{\frac{30 \cdot P \cdot G}{d^2}}$	4.85 (PK)	-5.48 (PK)	-4.17 (PK)
Bandwidth correction factor <sup>1.)</sup>	10.22	10.13	10.24
e.i.r.p. power [dBm] assumed 0dBi gain	15.07	4.64	6.06
Actual declared gain of antenna by applicant [dBi]	-0.42	0.58	0.71
<b>Final Result e.i.r.p. [dBm]:</b>	14.65	5.22	6.77

**Remark:** 1.) see 6dB BW results before

**g-MODE**

Maximum Radiated field strength@3m distance			
Set-up no.: 1 Op. Mode: 1	Low channel = 1 (2412 MHz)	Middle channel = 7 (2441 MHz)	High channel = 11 (2462 MHz)
Determined field strength [dBuV/m] in 3m distance with RBW=1MHz	87.90 (PK) 88.32 (AV)	100.34 (PK) 80.41 (AV)	102.2 (PK) 90.10 (AV)
Value in dBm using conversion formula and assumed numeric Gain=1: $E = \sqrt{\left(\frac{30 * P * G}{d^2}\right)}$	-7.32 (PK)	5.11 (PK)	6.97 (PK)
Bandwidth correction factor <sup>1.)</sup>	12.12	12.15	12.13
e.i.r.p. power [dBm] assumed 0dBi gain	4.79	17.27	19.10
Actual declared gain of antenna by applicant [dBi]	-0.42	0.58	0.71
<b>Final Result e.i.r.p. [dBm]:</b>	4.37	17.85	<b>19.81</b>

**Remark:** 1.) see 6dB BW results before

**n-MODE**

Maximum Radiated field strength@3m distance			
Set-up no.: 2 Op. Mode: 1	Low channel = 1 (2412 MHz)	Middle channel = 7 (2441 MHz)	High channel = 11 (2462 MHz)
Determined field strength [dBuV/m] in 3m distance with RBW=1MHz	101.08 (PK) 88.27 (AV)	102.43 (PK) 91.01 (AV)	98.72 (PK) 86.35 (AV)
Value in dBm using conversion formula and assumed numeric Gain=1: $E = \sqrt{\left(\frac{30 * P * G}{d^2}\right)}$	3.84 (PK)	5.24 (PK)	2.23 (PK)
Bandwidth correction factor <sup>1.)</sup>	12.44	12.43	12.45
e.i.r.p. power [dBm] assumed 0dBi gain	16.29	17.67	14.68
Actual declared gain of antenna by applicant [dBi]	-0.42	0.58	0.71
<b>Final Result e.i.r.p. [dBm]:</b>	15.87	18.25	15.39

**Remark:** 1.) see 6dB BW results before

**VERDICT:** pass, Maximum value: 19.81 dBm PK (antenna gain < 6 dBi)

### 5.4. Power Spectral Density

**TEST LOCATION AND EQUIPMENT** (for reference numbers please see chapter 'List of test equipment')

test location	<input checked="" type="checkbox"/> CETECOM Essen (Chapter. 2.2.1)	<input type="checkbox"/> Please see Chapter. 2.2.2	<input type="checkbox"/> Please see Chapter. 2.2.3
test site	<input type="checkbox"/> 441 EMI SAR	<input type="checkbox"/> 487 SAR NSA	<input type="checkbox"/> 337 OATS <input checked="" type="checkbox"/> 347 Radio.lab.
receiver	<input type="checkbox"/> 377 ESCS30	<input type="checkbox"/> 001 ESS	<input checked="" type="checkbox"/> 489 ESU
spectr. analys.	<input type="checkbox"/> 489 ESU	<input type="checkbox"/> 120 FSEM	<input type="checkbox"/> 264 FSEK
power supply	<input type="checkbox"/> 456 EA 3013A	<input type="checkbox"/> 457 EA 3013A	<input type="checkbox"/> 459 EA 2032-50 <input type="checkbox"/> 268 EA- 3050 <input type="checkbox"/> 494 AG6632A <input type="checkbox"/> 498 NGPE 40
otherwise	<input checked="" type="checkbox"/> 613 20dB Attenuator		<input checked="" type="checkbox"/> cable K4

**REFERENCES: §15.247(E), RSS-210:A8.3**

(e) For digitally modulated systems, the power spectral density conducted from the intentional radiator to the antenna shall not be greater than 8 dBm in any 3 kHz band during any time interval of continuous transmission. This power spectral density shall be determined in accordance with the provisions of paragraph (b) of this section. The same method of determining the conducted output power shall be used to determine the power spectral density.

**EUT SETTINGS:**

The EUT was instructed to send with maximum power (if adjustable) according applicants instructions. Different modulation characteristics have been checked, e.g. data rates which EUT can operate.

**MEASUREMENT METHOD:**

A frequency sweep around nominal carrier frequency is performed over the complete power envelope of the signal with PEAK detector, MAX hold mode. The maximum peak is located and the frequency recorded. With the nominal frequency set to the determined frequency in the step before, a new frequency sweep is performed with required resolution bandwidth of 3kHz.

The method is as shown in ANSI63.10:2009, chapter 6.11.2.3

The measured value is corrected due to external measuring set-up path-loss and the resulting value is compared with the standard requirement.

**RESULTS**

Set-up no.: 1 Op. Mode: 1	POWER SPECTRAL DENSITY		
	Low channel = 1 (2412 MHz)	Middle channel = 6 (2437 MHz)	High channel = 11 (2462 MHz)
Measured Level b-Mode [dBm/3kHz]	See table in annex A1	-4.35@1Mbps	See table in annex A1
Measured Level g-Mode [dBm/3kHz]		-6.34@6Mbps	
Measured Level n-Mode [dBm/3kHz]		-8.42@MCS0	
Correction factor-[dB] (Path loss+cable attenuation)	--	20.9 (set as correction factor in SA-> readings = final result)	--
Limit	< 8dBm/3kHz		

**Remark:** see diagrams for details on frequency in separate annex A1

**VERDICT:** pass

### 5.5. Transmitter frequency stability

**TEST LOCATION AND EQUIPMENT** (for reference numbers please see chapter 'List of test equipment')

test location	<input checked="" type="checkbox"/> CETECOM Essen (Chapter. 2.2.1)	<input type="checkbox"/> Please see Chapter. 2.2.2	<input type="checkbox"/> Please see Chapter. 2.2.3
test site	<input type="checkbox"/> 441 EMI SAR	<input type="checkbox"/> 487 SAR NSA	<input type="checkbox"/> 337 OATS
receiver	<input type="checkbox"/> 377 ESCS30	<input type="checkbox"/> 001 ESS	<input checked="" type="checkbox"/> 489 ESU
spectr. analys.	<input type="checkbox"/> 489 ESU	<input type="checkbox"/> 120 FSEM	<input type="checkbox"/> 264 FSEK
power supply	<input type="checkbox"/> 456 EA 3013A	<input type="checkbox"/> 457 EA 3013A	<input type="checkbox"/> 459 EA 2032-50
otherwise	<input checked="" type="checkbox"/> 613 20dB Attenuator	<input checked="" type="checkbox"/> cable K4	

**REFERENCES: RSS-GEN, CHAPTER 4.7**

„Frequency stability is a measure of frequency drift due to temperature and supply voltage variations with reference to the frequency measured at an appropriate reference temperature and the rated supply voltage. Unless specified otherwise in the RSS that is applicable to the device, the reference temperature for transmitters is +20°C“

**EUT SETTINGS:**

The EUT was instructed to send with maximum power (if adjustable) according applicants instructions. EUT was sending an unmodulated carrier according applicants instructions. A dummy battery was used together with a external power supply. The supply voltage delivered to the EUT was also changed within the real Li-Ion battery low and maximum voltage limits.

**MEASUREMENT METHOD:**

First the frequency deviation at room temperature (20°C) was recorded. All other records at different temperatures are referenced to this 20°C value.

After reaching the desired temperature a sufficient time was waited before recording the measurement values. An unmodulated carrier was established and spectrum analyzers build in frequency counter used. All values are compared to the nominal deviation at 20° as recorded before and the relative deviation calculated.

Frequency Error [ppm]			
Set-up no.: 1 Op-Mode: 2	Low channel = 1 (2412 MHz)	Middle channel = 6 (2437 MHz)	High channel = 11 (2462 MHz)
Unmodulated carrier (CW)	4.5667 ppm	<b>4.604 ppm</b>	4.5959 ppm
Limit	Operation within designated band		

Remark: 2.) maximum value among all data, pls. compare separate annex A1 for further details

**Verdict:** pass – operational frequency within designated operational band limits (2400MHz to 2483.5MHz)



### 5.6. Conducted emissions on AC-Power lines

**TEST LOCATION AND EQUIPMENT** (for reference numbers please see chapter 'List of test equipment')

test location	<input checked="" type="checkbox"/> CETECOM Essen (Chapter 2.2.1)	<input type="checkbox"/> Please see Chapter 2.2.2	<input type="checkbox"/> Please see Chapter 2.2.3
test site	<input type="checkbox"/> 333 EMI field	<input checked="" type="checkbox"/> 348 EMI cond.	
receiver	<input type="checkbox"/> 001 ESS	<input checked="" type="checkbox"/> 377 ESCS 30	
LISN	<input checked="" type="checkbox"/> 005 ESH2-Z5	<input type="checkbox"/> 007 ESH3-Z6	<input type="checkbox"/> 300 ESH3-Z5 & 50Ω used for AE <input type="checkbox"/> no LISN for AE
signaling	<input type="checkbox"/> 392 MT8820A	<input type="checkbox"/> 436 CMU	<input type="checkbox"/> 547 CMU
line voltage	<input type="checkbox"/> 230 V 50 Hz via public mains	<input checked="" type="checkbox"/> 060 110 V 60 Hz via PAS 5000	

**STANDARDS AND LIMITS: PART 15, SUBPART B, §15.107, §15.207, CANADA: RSS-Gen, ANSI C63.4:2009**

Frequency [MHz]	Conducted limit Class B [dBμV]	
	QUASI-Peak	AVERAGE
0.15 – 0.5	66 to 56*	56 to 46*
0.5 – 5	56	46
5 – 30	60	50

Remark: \* decreases with the logarithm of the frequency

**TEST CONDITION AND MEASUREMENT PROCEDURES TEST SET-UP**

link to test system (if used):	<input type="checkbox"/> air link	<input type="checkbox"/> cable connection	<input type="checkbox"/>
EUT-grounding	<input checked="" type="checkbox"/> none	<input type="checkbox"/> with power supply	<input type="checkbox"/> additional connection
Equipment set up	<input checked="" type="checkbox"/> table top (40 cm distance to reference ground plane (wall))		<input type="checkbox"/> floor standing EUT stands isolated on reference ground plane (floor)
Climatic conditions	Temperature: (22±3°C)		Rel. humidity: (40±20)%
EMI-Receiver (Analyzer) Settings	Span/Range: 150 kHz to 30 MHz RBW: 9 kHz Detector/Mode: Max PEAK-hold, repetitive scan for preliminary testing Quasi-Peak Detector and Average-Detector for final measurement according ANSI 63.4, CISPR 16		

Devices which can be connected to the public AC-power network, should be tested against the radio frequency voltage conducted back into the AC-power line in the frequency range 150kHz to 30 MHz. Compliance should be tested by measuring the radio frequency voltage between each power line and ground at the power terminals in the stated frequency range.

A 500ohm/50μH line impedance stabilization network (LISN) is used therefore. The EUT power input leads are connected through the LISN to the AC-power source. The LISN enclosure is electrically connected to the GND-plane. The measuring instrument is connected to the coaxial output of the LISN.

Tabletop devices were set-up on a 80 cm height over reference ground plane, floor standing equipment 10 cm raised above ground plane.

Measurements have been performed on each phase line and neutral line of the devices AC-power lines. The EUT was power supplied with 110 V/60Hz.

The EUT was tested in the defined operating mode and installed (connected) to accessory equipment according the general description of use given by the applicant.

**Preliminary testing** as a first step, determines the worst-case phase line (neutral or phase) as well as the most critical amplitude by changing the operating mode. A complete frequency-sweep is performed with PK-Detector.

**Final testing** for power phases and critical frequencies (Margin to AV- or QP limit lower than 3dB) as a second step includes measurements either on discrete frequency components with receivers detector set to Quasi-Peak and Average per frequency component or a complete frequency sweep with corresponding detector.

**RESULTS**

EUT Type and S/N or EUT set-up no.		EUT set-up 3			
Diagram No.	Command or EUT operating mode or operating mode no.	Detector (Peak, CISPR AV, CISPR QP)	Power line (L1, L2, L3, N)	Additional (scan-) information (e.g. Pre-test Fast scan, Maxhold, Final measurement)	Result (passed / failed /final measurement . necessary)
1.1	EUT operating mode 4+5	Peak, AV, QP	L1, N	The Diagram shows PK/AV detector measurements on L1 and N with maxhold mode. Final measurement QP and AV was carried out on at least one frequency (please see diagram)	Pass, Margin to limit > 6dB for each detector type

Remarks: The diagram contains the maximum values from L1 + N

Margin to Limit for verdict:  $M = L_T - R_R + C_{Loss}$

Abbreviations used:

- $R_R$  : Receiver readings in dB $\mu$ V
- $C_{Loss}$ : cable loss
- $L_T$  : Limit in dB $\mu$ V

**VERDICT**

Summary of measurement results for conducted emissions on AC-Power lines: Passed

### 5.7. Radiated field strength emissions below 30 MHz

**TEST LOCATION AND EQUIPMENT** (for reference numbers please see chapter 'List of test equipment')

test location	<input checked="" type="checkbox"/> CETECOM Essen (Chapter. 2.2.1)	<input type="checkbox"/> Please see Chapter. 2.2.2	<input type="checkbox"/> Please see Chapter. 2.2.3
test site	<input checked="" type="checkbox"/> 441 EMI SAR	<input type="checkbox"/> 487 SAR NSA	<input type="checkbox"/> 347 Radio.lab.
receiver	<input type="checkbox"/> 377 ESCS30	<input checked="" type="checkbox"/> 001 ESS	<input type="checkbox"/>
spectr. analys.	<input type="checkbox"/> 584 FSU	<input type="checkbox"/> 120 FSEM	<input type="checkbox"/> 264 FSEK
antenna	<input type="checkbox"/> 574 BTA-L	<input type="checkbox"/> 133 EMCO3115	<input type="checkbox"/> 302 BBHA9170
signaling	<input type="checkbox"/> 392 MT8820A	<input type="checkbox"/> 436 CMU	<input type="checkbox"/> 547 CMU
otherwise	<input type="checkbox"/> 400 FTC40x15E	<input type="checkbox"/> 401 FTC40x15E	<input type="checkbox"/> 110 USB LWL
DC power	<input type="checkbox"/> 456 EA 3013A	<input type="checkbox"/> 457 EA 3013A	<input type="checkbox"/> 459 EA 2032-50
line voltage	<input type="checkbox"/> 230 V 50 Hz via public mains	<input checked="" type="checkbox"/> 060 110 V 60 Hz	via PAS 5000

**STANDARDS AND LIMITS: CFR 47, §15.205, §15.209, RSS-Gen, ANSI C63.10:2009,**

Frequency [MHz]	Field strength		Measurement distance [meters]	Remarks
	[µV/m]	[dBuV/m]		
0.009 – 0.490	2400/f (kHz)	67.6 – 20Log(f) (kHz)	300	Correction factor used due to measurement distance of 3m
0.490 – 1.705	24000/f (kHz)	87.6 – 20 Log(f) (kHz)	30	Correction factor used due to measurement distance of 3m
1.705 – 30	30	29.54	30	Correction factor used due to measurement distance of 3m

Remark: \* decreases with the logarithm of the frequency

**TEST CONDITION AND MEASUREMENT TEST SET-UP**

link to test system (if used):	<input type="checkbox"/> air link	<input type="checkbox"/> cable connection	<input type="checkbox"/>
EUT-grounding	<input type="checkbox"/> none	<input type="checkbox"/> with power supply	<input type="checkbox"/> additional connection
Equipment set up	<input checked="" type="checkbox"/> table top		<input type="checkbox"/> floor standing
Climatic conditions	Temperature: (22±3°C)		Rel. humidity: (40±20)%
EMI-Receiver (Analyzer) Settings	Span/Range: 9kHz to 150kHz; 150 kHz to 30 MHz RBW/VBW: 200Hz/auto; 10 kHz/ auto (ANSI63.10/CISPR#16) Detector/ Mode: PEAK, TRACE max-hold mode, repetitive scan for exploratory measurements Quasi-Peak, for final measurement on critical frequencies (f<1GHz)		

**GENERAL MEASUREMENT PROCEDURES:**

The measurement test set-up and test procedure are in accordance with the provisions described in ANSI 63.10: 2009

The **Equipment under Test** (EUT) was set-up to defined operating mode and installed (connected) to accessory equipment according the general description of use given by the applicant.

The measurement loop antenna was situated in 3m distance to the EUT. Between EUT and measurement antenna absorbers are covering the GND-Plane. With these absorbers the chamber fulfills CIPR16-1-4 site VSWR-criteria. Radiated magnetic emission measurements were made with the antenna situated in 1 meter height. The loop antenna was moved at least to 2-perpendicular axes (antenna vector in direction of EUT and parallel to EUT) in order to maximize the emissions, the EUT itself either over 3-orthogonal axes (no defined usage position) or 2-orthogonal axis (defined usage position) by the position manipulator.

According the standard the compliance should be checked in 30m and 300m measurement distance. Therefore a additional extrapolation factor was used in order to normalize the measurement data. The frequency dependent extrapolation factor used for this reduced measurement distance, can be found in the chapter annexes.

**MEASUREMENT RESULTS**

**b-Mode/1MBps**

Set-up No.		2								
Operating Mode		1								
Diagram no.	Frequency (kHz)	MaxPeak (dBμV/m)	Meas. Time (ms)	Bandwidth (kHz)	Antenna height (cm)	Polarity	Turntable position (deg)	Corr. (dB)	Margin (dB)	Limit (dBμV/m)
3.01	9..150	-57.89	10	0.200	100	--	0°..360°	300->3m	>20dB	See diagram
	150..500	<-65.0	10	10.0						
	500..30000	<18.07	10	10.0				300->3m 30->3m	>11.47	
3.02	9..150	-56.77	10	0.200	100	--	0°..360°	300->3m	>20dB	See diagram
	150..500	<-65.0	10	10.0						
	500..30000	<17.37	10	10.0				300->3m 30->3m	>12.17	
3.03	9..150	-58.13	10	0.200	100	--	0°..360°	300->3m	>20dB	See diagram
	150..500	<-65.0	10	10.0						
	500..30000	<17.94	10	10.0				300->3m 30->3m	>11.6	

Remark: 1.) see diagrams in annex A1

**g-Mode/6MBps**

Set-up No.		2								
Operating Mode		1								
Diagram no.	Frequency (kHz)	MaxPeak (dBμV/m)	Meas. Time (ms)	Bandwidth (kHz)	Antenna height (cm)	Polarity	Turntable position (deg)	Corr. (dB)	Margin (dB)	Limit (dBμV/m)
3.04	9..150	-56.62	10	0.200	100	--	0°..360°	300->3m	>20dB	See diagram
	150..500	<-65.0	10	10.0						
	500..30000	<17.98	10	10.0				300->3m 30->3m	>11.56	
3.05	9..150	-57.89	10	0.200	100	--	0°..360°	300->3m	>20dB	See diagram
	150..500	<-65.0	10	10.0						
	500..30000	<17.12	10	10.0				300->3m 30->3m	>12.42	
3.06	9..150	-57.12	10	0.200	100	--	0°..360°	300->3m	>20dB	See diagram
	150..500	<-65.0	10	10.0						
	500..30000	<17.67	10	10.0				300->3m 30->3m	>11.87	

Remark: 1.) see diagrams in annex A1

**n-Mode/MCS0**

Set-up No.		2								
Operating Mode		1								
Diagram no.	Frequency (kHz)	MaxPeak (dBµV/m)	Meas. Time (ms)	Bandwidth (kHz)	Antenna height (cm)	Polarity	Turntable position (deg)	Corr. (dB)	Margin (dB)	Limit (dBµV/m)
3.17	9..150	-58.35	10	0.200	100	--	0°..360°	300->3m	>20dB	See diagram
	150..500	<-65.0	10	10.0						
	500..30000	<17.41	10	10.0				300->3m 30->3m	>12.13	
3.18	9..150	-56.60	10	0.200	100	--	0°..360°	300->3m	>20dB	See diagram
	150..500	<-65.0	10	10.0						
	500..30000	<17.77	10	10.0				300->3m 30->3m	>11.84	
3.19	9..150	-58.70	10	0.200	100	--	0°..360°	300->3m	>20dB	See diagram
	150..500	<-65.0	10	10.0						
	500..30000	<18.33	10	10.0				300->3m 30->3m	>11.21	

Remark: 1.) see diagrams in annex A1

<p><b>Margin to Limit:</b></p> $M = L_T - R_R + C_F + D_F$ $= L_T - R_R + (AF_{ANTENNA} + Cable_{LOSS}) + D_F$ <p>Remark: positive margin means passed result</p>	<p><b>Abbreviations used:</b></p> <ul style="list-style-type: none"> <li>• <math>R_R</math> : Receiver readings in dBµV/m</li> <li>• <math>C_F</math>: Transducer in dB = AF (antenna factor) + CL (cable loss)</li> <li>• <math>D_F</math>: distance correction factor (if different measurement distance used than specified in the standard)</li> <li>• <math>L_T</math> : Limit in dBµV/m</li> </ul>
---	--

**VERDICT:** Summary of measurement results for radiated frequencies below 30 MHz - passed

### 5.8. Radiated field strength emissions

#### TEST LOCATION AND EQUIPMENT (for reference numbers please see chapter 'List of test equipment')

test location	<input checked="" type="checkbox"/> CETECOM Essen (Chapter. 2.2.1)	<input type="checkbox"/> Please see Chapter. 2.2.2	<input type="checkbox"/> Please see Chapter. 2.2.3
test site	<input checked="" type="checkbox"/> 441 EMI SAR	<input type="checkbox"/> 487 SAR NSA	
receiver	<input type="checkbox"/> 377 ESCS30	<input checked="" type="checkbox"/> 001 ESS	<input type="checkbox"/>
spectr. analys.	<input type="checkbox"/> 584 FSU	<input type="checkbox"/> 120 FSEM	<input type="checkbox"/> 264 FSEK
antenna	<input checked="" type="checkbox"/> 574 BTA-L	<input type="checkbox"/> 133 EMCO3115	<input type="checkbox"/> 302 BBHA9170 <input type="checkbox"/> 289 CBL 6141 <input type="checkbox"/> 030 HFH-Z2 <input type="checkbox"/> 477 GPS
signaling	<input type="checkbox"/> 392 MT8820A	<input type="checkbox"/> 436 CMU	<input type="checkbox"/> 547 CMU
otherwise	<input type="checkbox"/> 400 FTC40x15E	<input type="checkbox"/> 401 FTC40x15E	<input type="checkbox"/> 110 USB LWL <input checked="" type="checkbox"/> 482 Filter Matrix
DC power	<input type="checkbox"/> 456 EA 3013A	<input type="checkbox"/> 457 EA 3013A	<input type="checkbox"/> 459 EA 2032-50 <input type="checkbox"/> 268 EA- 3050 <input type="checkbox"/> 494 AG6632A <input type="checkbox"/> 498 NGPE
line voltage	<input type="checkbox"/> 230 V 50 Hz via public mains	<input type="checkbox"/> 060 110 V 60 Hz via PAS 5000	

#### STANDARDS AND LIMITS: CFR 47, PART 15B, §15.209, RSS-Gen, ANSI C63.10:2009 (TX), ANSI 63.4:2009 (RX-MODE)

Frequency [MHz]	Radiated emission limits, Class B, 3 meters	
	QUASI-Peak [microvolts/meter]	QUASI-Peak [dBµV/m]
30-88	100	40
88-216	150	43,5
216-960	200	46,0
above 960	500	54,0

#### TEST CONDITION AND MEASUREMENT TEST SET-UP

link to test system (if used):	<input type="checkbox"/> air link	<input type="checkbox"/> cable connection	<input type="checkbox"/>
EUT-grounding	<input checked="" type="checkbox"/> none	<input type="checkbox"/> with power supply	<input type="checkbox"/> additional connection
Equipment set up	<input checked="" type="checkbox"/> table top 0.8m height		<input type="checkbox"/> floor standing
Climatic conditions	Temperature: (22±3°C)		Rel. humidity: (40±20)%
EMI-Receiver (Analyzer) Settings	Span/Range: 30 MHz to 1 GHz RBW/VBW: 120 kHz / (auto) Detector/ Mode: PEAK, TRACE max-hold mode, repetitive scan Quasi-Peak, for final measurement for critical measurements		

#### RESTRICTED BANDS OF OPERATION, §15.205

MHz	MHz	MHz	GHz
0.090-0.110	16.42-16.423	399.9-410	4.5-5.15
0.495-0.505	16.69475-16.69525	608-614	5.35-5.46
2.1735-2.1905	16.80425-16.80475	960-1240	7.25-7.75
4.125-4.128	25.5-25.67	1300-1427	8.025-8.5
4.20725-4.20775	73-74.6	1645.5-1646.5	9.3-9.5
6.215-6.218	74.8-75.2	1660-1710	10.6-12.7
6.26775-6.26825	108-121.94	1718.8-1722.2	13.25-13.4
6.31175-6.31225	123-138	2200-2300	14.47-14.5
8.291-8.294	149.9-150.05	2310-2390	15.35-16.2
8.362-8.366	156.52475-156.52525	2483.5-2500	17.7-21.4
8.37625-8.38675	156.7-156.9	2690-2900	22.01-23.12
8.41425-8.41475	162.0125-167.17	3260-3267	23.6-24.0
12.29-12.293	167.72-173.2	3332-3339	31.2-31.8
12.51975-12.52025	240-285	3345.8-3358	36.43-36.5
12.57675-12.57725	322-335.4	3600-4400	--
13.36-13.41	--	--	--

Remark: only spurious emissions are allowed within these frequency bands and not exceeding the limits as per §15.209

**GENERAL MEASUREMENT PROCEDURES:**

The measurement test set-up and test procedure are in accordance with the provisions described in ANSI63.10:2009 for TX-Mode.

The *Equipment under Test* (EUT) set-up to defined operating mode and installed (connected) to accessory equipment according the general description of use given by the applicant.

**5.8.1. RESULTS FOR TX-MODE (EUT B ALONE TESTED)**

All results are under the general emission limits of §15.209.

**b-mode, 1MBps**

Set-up No.		2								
Operating Mode		1								
Diagram no.	Frequency (MHz)	MaxPeak (dB $\mu$ V/m)	Meas. Time (ms)	Bandwidth (kHz)	Antenna height (m)	Polarity	Turntable position (deg)	Corr. (dB) (C <sub>F</sub> )	Margin (dB) (M)	Limit (dB $\mu$ V/m) (L <sub>T</sub> )
B_2.01	30..1000	41.28 (PK)	0.005	120.0	1.4	H/V	0°..360°	--	4.62	46.0
B_2.02	30..1000	41.75 (PK)	0.005	120.0	1.4	H/V	0°..360°	--	4.25	46.0
B_2.03	30..1000	41.69 (PK)	0.005	120.0	1.4	H/V	0°..360°	--	4.31	46.0

Remark: see also plots enclosed in separate annex A1

**g-mode, 6MBps**

Set-up No.		2								
Operating Mode		1								
Diagram no.	Frequency (MHz)	MaxPeak (dB $\mu$ V/m)	Meas. Time (ms)	Bandwidth (kHz)	Antenna height (m)	Polarity	Turntable position (deg)	Corr. (dB) (C <sub>F</sub> )	Margin (dB) (M)	Limit (dB $\mu$ V/m) (L <sub>T</sub> )
B_2.04	30..1000	41.19 (PK)	0.005	120.0	1.4	H/V	0°..360°	--	4.81	46.0
B_2.05	30..1000	37.25 (PK)	0.005	120.0	1.4	H/V	0°..360°	--	8.75	46.0
B_2.06	30..1000	42.5 (PK)	0.005	120.0	1.4	H/V	0°..360°	--	3.5	46.0

Remark: see also plots enclosed in separate annex A1

**n-mode, MCS0**

Set-up No.		2								
Operating Mode		1								
Diagram no.	Frequency (MHz)	MaxPeak (dB $\mu$ V/m)	Meas. Time (ms)	Bandwidth (kHz)	Antenna height (m)	Polarity	Turntable position (deg)	Corr. (dB) (C <sub>F</sub> )	Margin (dB) (M)	Limit (dB $\mu$ V/m) (L <sub>T</sub> )
B_2.07	30..1000	42.5 (PK)	0.005	120.0	1.4	H/V	0°..360°	--	3.5	46.0
B_2.08	30..1000	42.5 (PK)	0.005	120.0	1.4	H/V	0°..360°	--	3.5	46.0
B_2.09	30..1000	42.5 (PK)	0.005	120.0	1.4	H/V	0°..360°	--	3.5	46.0

Remark: see also plots enclosed in separate annex A1



**5.8.2. RESULTS FOR RX-MODE**

Set-up No.		3								
Operating Mode		3+5								
Diagram no.	Frequency (MHz)	MaxPeak (dB $\mu$ V/m)	Meas. Time (ms)	Bandwidth (kHz)	Antenna height (cm)	Polarity	Turntable position (deg)	Corr. (dB) (C <sub>F</sub> )	Margin (dB) (M)	Limit (dB $\mu$ V/m) (L <sub>T</sub> )
2.10_RX	335.97	33.5	1000	120.0	304	H	284	16.3	12.5	46.0

Remark: Remark: see also plots enclosed in separate annex A1

**5.8.3. RESULTS FOR INTERMODULATION (WLAN/ BLUETOOTH/GSM OR W-CDMA TX ACTIVE)**

**b-Mode/CH11/1Mbps)**

Set-up No.		2								
Operating Mode		1+ GSM850 + BT (GFSK)								
Diagram no.	Frequency (MHz)	MaxPeak (dB $\mu$ V/m)	Meas. Time (ms)	Bandwidth (kHz)	Antenna height (cm)	Polarity	Turntable position (deg)	Corr. (dB) (C <sub>F</sub> )	Margin (dB) (M)	Limit (dB $\mu$ V/m) (L <sub>T</sub> )
E_2.01	30..1000	< 42.0	1000	120.0	100..400	H/V	0°..360°	--	>4 (PK)	46.0

Remark: see also plots enclosed in separate annex A1

Peak over limit due to wanted TCH and BCCH carriers of TX-mode/GSM850

**g-Mode/CH11/6Mbps**

Set-up No.		2								
Operating Mode		1+ GSM1900+ BT (pi/4 DQPSK)								
Diagram no.	Frequency (MHz)	MaxPeak (dB $\mu$ V/m)	Meas. Time (ms)	Bandwidth (kHz)	Antenna height (cm)	Polarity	Turntable position (deg)	Corr. (dB) (C <sub>F</sub> )	Margin (dB) (M)	Limit (dB $\mu$ V/m) (L <sub>T</sub> )
E_2.02	30..1000	< 42.0	1000	120.0	100..400	H/V	0°..360°	--	>4 (PK)	46.0

Remark: see also plots enclosed in separate annex A1

**n-Mode/CH11/MCS0**

Set-up No.		2								
Operating Mode		1+ FDD Band 2+ BT (8DPSK)								
Diagram no.	Frequency (MHz)	MaxPeak (dB $\mu$ V/m)	Meas. Time (ms)	Bandwidth (kHz)	Antenna height (cm)	Polarity	Turntable position (deg)	Corr. (dB) (C <sub>F</sub> )	Margin (dB) (M)	Limit (dB $\mu$ V/m) (L <sub>T</sub> )
E_2.03	30..1000	< 42.0	1000	120.0	100..400	H/V	0°..360°	--	>4 (PK)	46.0

Remark: see also plots enclosed in separate annex A1

b-Mode/CH11/1Mbps

Set-up No.		2								
Operating Mode		1+ FDD Band 5+ BT (8DPSK)								
Diagram no.	Frequency (MHz)	MaxPeak (dBµV/m)	Meas. Time (ms)	Bandwidth (kHz)	Antenna height (cm)	Polarity	Turntable position (deg)	Corr. (dB) (C <sub>F</sub> )	Margin (dB) (M)	Limit (dBµV/m) (L <sub>T</sub> )
E_2.04	30..1000	< 42.5	1000	120.0	100..400	H/V	0°..360°	--	>3.5 (PK)	46.0

Remark: see also plots enclosed in separate annex A1

Peak over limit due to wanted TCH and BCCH carriers of TX-mode/GSM850

<p><b>Margin to Limit:</b></p> $M = L_T - R_R + C_F + D_F$ $= L_T - R_R + (AF_{ANTENNA} + Cable_{LOSS}) + D_F$ <p>Remark: positive margin means passed result</p>	<p><b>Abbreviations used:</b></p> <ul style="list-style-type: none"> <li>• R<sub>R</sub> : Receiver readings in dBµV/m</li> <li>• C<sub>F</sub>: Transducer in dB = AF (antenna factor) + CL (cable loss)</li> <li>• D<sub>F</sub>: distance correction factor (if different measurement distance used than specified in the standard)</li> <li>• L<sub>T</sub> : Limit in dBµV/m</li> </ul>
---	--

**VERDICT**

Summary of measurement results for radiated emissions above 30 MHz and below 1 GHz : Passed

### 5.9. Radiated emissions, above 1GHz

#### TEST LOCATION AND EQUIPMENT (for reference numbers please see chapter 'List of test equipment')

test site	<input type="checkbox"/> 441 EMI SAR	<input type="checkbox"/> 348 EMI cond.	<input checked="" type="checkbox"/> 443 EMI FAR	<input type="checkbox"/> 347 Radio.lab.	<input type="checkbox"/> 337 OATS	<input type="checkbox"/>
equipment	<input type="checkbox"/> 331 HC 4055	<input type="checkbox"/>	<input type="checkbox"/>	<input type="checkbox"/>	<input type="checkbox"/>	<input type="checkbox"/>
spectr. analys.	<input type="checkbox"/> 584 FSU	<input type="checkbox"/> 120 FSEM	<input type="checkbox"/> 264 FSEK	<input checked="" type="checkbox"/> 489 ESU	<input type="checkbox"/>	<input type="checkbox"/>
antenna meas	<input type="checkbox"/> 574 BTA-L	<input type="checkbox"/> 289 CBL 6141	<input type="checkbox"/> 608 HL 562	<input checked="" type="checkbox"/> 549 HL025	<input type="checkbox"/> 302 BBHA9170	<input type="checkbox"/> 477 GPS
antenna meas	<input type="checkbox"/> 123 HUF-Z2	<input type="checkbox"/> 132 HUF-Z3	<input type="checkbox"/> 030 HFH-Z2	<input type="checkbox"/>	<input type="checkbox"/>	<input type="checkbox"/>
antenna subst	<input type="checkbox"/> 071 HUF-Z2	<input type="checkbox"/> 020 EMCO3115	<input type="checkbox"/> 063 LP 3146	<input type="checkbox"/> 303 BBHA9170	<input type="checkbox"/>	<input type="checkbox"/>
power meter	<input type="checkbox"/> 009 NRV	<input type="checkbox"/> 010 URV5-Z2	<input type="checkbox"/> 011 URV5-Z2	<input type="checkbox"/>	<input type="checkbox"/>	<input type="checkbox"/>
signalgener.	<input type="checkbox"/> 008 SMG	<input type="checkbox"/> 140 SMHU	<input type="checkbox"/> 263 SMP04	<input type="checkbox"/>	<input type="checkbox"/>	<input type="checkbox"/>
power meter	<input type="checkbox"/> 262 NRV-S	<input type="checkbox"/> 266 NRV-Z31	<input type="checkbox"/> 265 NRV-Z33	<input type="checkbox"/> 261 NRV-Z55	<input type="checkbox"/> 356 NRV-Z1	<input type="checkbox"/>
multimeter	<input type="checkbox"/> 341 Fluke 112	<input type="checkbox"/>	<input type="checkbox"/>	<input type="checkbox"/>	<input type="checkbox"/>	<input type="checkbox"/>
signaling	<input type="checkbox"/> 392 MT8820A	<input type="checkbox"/> 436 CMU	<input type="checkbox"/> 547 CMU			
DCpower	<input type="checkbox"/> 086 LNG50-10	<input type="checkbox"/> 087 EA3013	<input type="checkbox"/> 354 NGPE 40	<input type="checkbox"/> 349 car battery	<input type="checkbox"/> 350 Car battery	<input type="checkbox"/>
line voltage	<input type="checkbox"/> 230 V 50 Hz via public mains		<input type="checkbox"/> 060 110 V 60 Hz via PAS 5000			

#### STANDARDS AND LIMITS: CFR 47, §15.109 (CLASS B), §15.209, RSS-Gen, RSS-210, ANSI C 63.10:2009

Frequency [MHz]	Radiated emission limits, 3 meters measurement distance			
	AV [microvolts/meter]	AV [dBµV/m]	Peak [microvolts/meter]	Peak [dBµV/m]
above 1GHz	500	54.0	5000	74.0

#### TEST CONDITION AND MEASUREMENT TEST SET-UP

link to test system (if used):	<input type="checkbox"/> air link	<input type="checkbox"/> cable connection	<input type="checkbox"/>
EUT-grounding	<input checked="" type="checkbox"/> none	<input type="checkbox"/> with power supply	<input type="checkbox"/> additional connection
Equipment set up	<input checked="" type="checkbox"/> table top 1.5m height	<input type="checkbox"/> floor standing	
Climatic conditions	Temperature: (22±3°C)		Rel. humidity: (40±20)%
Spectrum-Analyzer settings	Span/Frequency range : 1..25 GHz +single frequencies determined in step 1 RBW/VBW: 1 MHz / 3 MHz Detector/ Mode: Peak, MAX-hold, repetitive scan for exploratory measurement PEAK/ AVERAGE, for final measurement for critical frequencies Antenna Polarisation Horizontal / Vertical		

#### GENERAL MEASUREMENT PROCEDURES:

The measurement test set-up and test procedure are in accordance with the provisions described in ANSI C.63.4: 2009 (RX) or ANSI C.63.10:2009 (TX)

The **Equipment under Test** (EUT) was placed on a non-conductive positioning table of 0.8 or 1.5 meter height depending from the frequency range. The measuring distance was set to 3 meter for frequencies up to 18GHz and 1 meter above 18GHz.

The EUT was set-up to defined operating mode and installed (connected) to accessory equipment according the general description of use given by the applicant.

For the upper frequency measurement range, it was assumed that the highest frequency generated in the device is same as the highest operable TX-frequency in WLAN Mode (2462 MHz). For practical reasons the upper frequency limit was set to 25GHz.

**1. Step exploratory measurement:** see above description as in the frequency range lower 1GHz.

**2. Step Final Measurement(1 GHz<f <18 GHz):** On the Worst-Case EUT configuration, frequency components with a margin lower than 6 dB to the limits, will be re-measured by maintaining the EUT's operating mode, cable position, etc.. For find the worst-case emission, the turntable was changed in the range 0 to 360 degree and the EUT itself either over 3-orthogonal axis (not defined usage position) or 2-orthogonal axis (defined usage position). The measurements are performed for both polarizations of the measuring antenna: horizontal and vertical.

**5.9.1. RESULTS FOR TX-MODE (WLAN ONLY)**

**b-Mode/1MBps/Channel 1**

Set-up No.:		2								
Operating Mode:		1								
Diagram no.	Frequency (MHz)	MaxPeak (dB $\mu$ V/m)	Meas. Time (ms)	Bandwidth (kHz)	Antenna height (cm)	Polarity	Turntable position (deg)	Corr. (dB) (C <sub>F</sub> )	Margin (dB) (M)	Limit (dB $\mu$ V/m) (L <sub>T</sub> )
8.01a	PK-detector									
	1000 - 2800	59.0	5	1000	100	H/V	0°..360°	--	>15.0	74.0
	AV-detector									
	1000 - 2800	46.0	5	1000	100	H/V	0°..360°	--	>8.0	54.0

Remark: --

**b-Mode/1MBps/Channel 1**

Set-up No.:		2								
Operating Mode:		1								
Diagram no.	Frequency (MHz)	MaxPeak (dB $\mu$ V/m)	Meas. Time (ms)	Bandwidth (kHz)	Antenna height (cm)	Polarity	Turntable position (deg)	Corr. (dB) (C <sub>F</sub> )	Margin (dB) (M)	Limit (dB $\mu$ V/m) (L <sub>T</sub> )
8.01b	PK-detector									
	2800 - 18000	65.0	5	1000	100	H/V	0°..360°	--	>9.0	74.0
	AV-detector									
	4824.0	35.6	100	1000	100	H	136°	2.7	18.4	54.0
	9648.0	44.0	100	1000	100	V	322°	13.6	--*	--*

Remark: \*.) General limit accord. §15.209 not applicable

**b-Mode/1MBps/Channel 1**

Set-up No.:		2								
Operating Mode:		1								
Diagram no.	Frequency (MHz)	MaxPeak (dB $\mu$ V/m)	Meas. Time (ms)	Bandwidth (kHz)	Antenna height (cm)	Polarity	Turntable position (deg)	Corr. (dB) (C <sub>F</sub> )	Margin (dB) (M)	Limit (dB $\mu$ V/m) (L <sub>T</sub> )
8.01c	PK-detector									
	18000 - 25000	< 67.34	5	1000	100	H/V	0°..360°	--	>6.66	74.0
	AV-detector									
	18000 - 25000	< 53.74	100	1000	100	H/V	0°..360°	--	--	54.0

Remark: overview measurement only -> no peaks discovered

**b-Mode/1MBps/Channel 7**

Set-up No.:		2								
Operating Mode:		1								
Diagram no.	Frequency (MHz)	MaxPeak (dB $\mu$ V/m)	Meas. Time (ms)	Bandwidth (kHz)	Antenna height (cm)	Polarity	Turntable position (deg)	Corr. (dB) (C <sub>F</sub> )	Margin (dB) (M)	Limit (dB $\mu$ V/m) (L <sub>T</sub> )
8.02a	PK-detector									
	1000 - 2800	59.0	5	1000	100	H/V	0°..360°	--	>15.0	74.0
	AV-detector									
	1000 - 2800	46.0	5	1000	100	H/V	0°..360°	--	>8.0	54.0

Remark: --

**b-Mode/1MBps/Channel 7**

Set-up No.:		2								
Operating Mode:		1								
Diagram no.	Frequency (MHz)	MaxPeak (dB $\mu$ V/m)	Meas. Time (ms)	Bandwidth (kHz)	Antenna height (cm)	Polarity	Turntable position (deg)	Corr. (dB) (C <sub>F</sub> )	Margin (dB) (M)	Limit (dB $\mu$ V/m) (L <sub>T</sub> )
8.02b	PK-detector									
	2800 - 18000	65.0	5	1000	100	H/V	0°..360°	--	>9.0	74.0
	AV-detector									
	4884.0	38.2	100	1000	100	H	137°	2.9	15.8	54.0
	9768.0	44.2	100	1000	100	V	320°	13.8	--*	--*

Remark: \*.) General limit accord. §15.209 not applicable

**b-Mode/1MBps/Channel 7**

Set-up No.:		2								
Operating Mode:		1								
Diagram no.	Frequency (MHz)	MaxPeak (dB $\mu$ V/m)	Meas. Time (ms)	Bandwidth (kHz)	Antenna height (cm)	Polarity	Turntable position (deg)	Corr. (dB) (C <sub>F</sub> )	Margin (dB) (M)	Limit (dB $\mu$ V/m) (L <sub>T</sub> )
8.02c	PK-detector									
	18000 - 25000	< 67.27	5	1000	100	H/V	0°..360°	--	>6.66	74.0
	AV-detector									
	18000 - 25000	< 53.95	100	1000	100	H/V	0°..360°	--	--	54.0

Remark: overview measurement only -> no peaks discovered

**b-Mode/1MBps/Channel 11**

Set-up No.:		2								
Operating Mode:		1								
Diagram no.	Frequency (MHz)	MaxPeak (dB $\mu$ V/m)	Meas. Time (ms)	Bandwidth (kHz)	Antenna height (cm)	Polarity	Turntable position (deg)	Corr. (dB) (C <sub>F</sub> )	Margin (dB) (M)	Limit (dB $\mu$ V/m) (L <sub>T</sub> )
8.03a	PK-detector									
	1000 - 2800	59.0	5	1000	100	H/V	0°..360°	--	>15.0	74.0
	AV-detector									
	1000 - 2800	46.0	5	1000	100	H/V	0°..360°	--	>8.0	54.0

Remark: --

**b-Mode/1MBps/Channel 11**

Set-up No.:		2								
Operating Mode:		1								
Diagram no.	Frequency (MHz)	MaxPeak (dB $\mu$ V/m)	Meas. Time (ms)	Bandwidth (kHz)	Antenna height (cm)	Polarity	Turntable position (deg)	Corr. (dB) (C <sub>F</sub> )	Margin (dB) (M)	Limit (dB $\mu$ V/m) (L <sub>T</sub> )
8.03b	PK-detector									
	2800 - 18000	65.0	5	1000	100	H/V	0°..360°	--	>9.0	74.0
	AV-detector									
	4924.0	37.9	100	1000	100	H	209°	3.1	16.1	54.0
	9848.0	44.0	100	1000	100	V	322°	13.6	--*	--*

Remark: \*.) General limit accord. §15.209 not applicable

**b-Mode/1MBps/Channel 11**

Set-up No.:		2								
Operating Mode:		1								
Diagram no.	Frequency (MHz)	MaxPeak (dB $\mu$ V/m)	Meas. Time (ms)	Bandwidth (kHz)	Antenna height (cm)	Polarity	Turntable position (deg)	Corr. (dB) (C <sub>F</sub> )	Margin (dB) (M)	Limit (dB $\mu$ V/m) (L <sub>T</sub> )
8.03c	PK-detector									
	18000 - 25000	< 67.59	5	1000	100	H/V	0°..360°	--	>6.66	74.0
	AV-detector									
	18000 - 25000	< 53.73	100	1000	100	H/V	0°..360°	--	--	54.0

Remark: overview measurement only -> no peaks discovered

**g-Mode/6MBps/Channel 1**

Set-up No.:		2								
Operating Mode:		1								
Diagram no.	Frequency (MHz)	MaxPeak (dB $\mu$ V/m)	Meas . Time (ms)	Bandwidth (kHz)	Antenna height (cm)	Polarity	Turntable position (deg)	Corr. (dB) (C <sub>F</sub> )	Margin (dB) (M)	Limit (dB $\mu$ V/m) (L <sub>T</sub> )
8.04a	PK-detector									
	1000 - 2800	59.0	5	1000	100	H/V	0°..360°	--	>15.0	74.0
	AV-detector									
	1000 - 2800	46.0	5	1000	100	H/V	0°..360°	--	>8.0	54.0

Remark: --

**g-Mode/6MBps/Channel 1**

Set-up No.:		2								
Operating Mode:		1								
Diagram no.	Frequency (MHz)	MaxPeak (dB $\mu$ V/m)	Meas . Time (ms)	Bandwidth (kHz)	Antenna height (cm)	Polarity	Turntable position (deg)	Corr. (dB) (C <sub>F</sub> )	Margin (dB) (M)	Limit (dB $\mu$ V/m) (L <sub>T</sub> )
8.04b	PK-detector									
	2800 - 18000	64.0	5	1000	100	H/V	0°..360°	--	>10.0	74.0
	AV-detector									
	2800 - 18000	51.0	5	1000	100	H/V	0°..360°	--	>4.0	54.0

Remark: --

**g-Mode/6MBps/Channel 1**

Set-up No.:		2								
Operating Mode:		1								
Diagram no.	Frequency (MHz)	MaxPeak (dB $\mu$ V/m)	Meas . Time (ms)	Bandwidth (kHz)	Antenna height (cm)	Polarity	Turntable position (deg)	Corr. (dB) (C <sub>F</sub> )	Margin (dB) (M)	Limit (dB $\mu$ V/m) (L <sub>T</sub> )
8.04c	PK-detector									
	18000 - 25000	< 67.77	5	1000	100	H/V	0°..360°	--	>6.66	74.0
	AV-detector									
	18000 - 25000	< 53.71	100	1000	100	H/V	0°..360°	--	--	54.0

Remark: overview measurement only -> no peaks discovered

**g-Mode/6MBps/Channel 7**

Set-up No.:		2								
Operating Mode:		1								
Diagram no.	Frequency (MHz)	MaxPeak (dB $\mu$ V/m)	Meas . Time (ms)	Bandwidth (kHz)	Antenna height (cm)	Polarity	Turntable position (deg)	Corr. (dB) (C <sub>F</sub> )	Margin (dB) (M)	Limit (dB $\mu$ V/m) (L <sub>T</sub> )
8.05a	PK-detector									
	1000 - 2800	60.0	5	1000	100	H/V	0°..360°	--	>14.0	74.0
	AV-detector									
	1000 - 2800	46.0	5	1000	100	H/V	0°..360°	--	>8.0	54.0

Remark: --

**g-Mode/6MBps/Channel 7**

Set-up No.:		2								
Operating Mode:		1								
Diagram no.	Frequency (MHz)	MaxPeak (dB $\mu$ V/m)	Meas . Time (ms)	Bandwidth (kHz)	Antenna height (cm)	Polarity	Turntable position (deg)	Corr. (dB) (C <sub>F</sub> )	Margin (dB) (M)	Limit (dB $\mu$ V/m) (L <sub>T</sub> )
8.05b	PK-detector									
	2800 - 18000	64.0	5	1000	100	H/V	0°..360°	--	>10.0	74.0
	AV-detector									
	2800 - 18000	51.0	5	1000	100	H/V	0°..360°	--	>4.0	54.0

Remark: --

**g-Mode/6MBps/Channel 7**

Set-up No.:		2								
Operating Mode:		1								
Diagram no.	Frequency (MHz)	MaxPeak (dB $\mu$ V/m)	Meas . Time (ms)	Bandwidth (kHz)	Antenna height (cm)	Polarity	Turntable position (deg)	Corr. (dB) (C <sub>F</sub> )	Margin (dB) (M)	Limit (dB $\mu$ V/m) (L <sub>T</sub> )
8.05c	PK-detector									
	18000 - 25000	< 67.75	5	1000	100	H/V	0°..360°	--	>6.66	74.0
	AV-detector									
	18000 - 25000	< 53.81	100	1000	100	H/V	0°..360°	--	--	54.0

Remark: overview measurement only -> no peaks discovered



**g-Mode/6MBps/Channel 11**

Set-up No.:		2								
Operating Mode:		1								
Diagram no.	Frequency (MHz)	MaxPeak (dB $\mu$ V/m)	Meas . Time (ms)	Bandwidth (kHz)	Antenna height (cm)	Polarity	Turntable position (deg)	Corr. (dB) (C <sub>F</sub> )	Margin (dB) (M)	Limit (dB $\mu$ V/m) (L <sub>T</sub> )
8.06a	PK-detector									
	1000 - 2800	60.0	5	1000	100	H/V	0°..360°	--	>14.0	74.0
	AV-detector									
	1000 - 2800	46.0	5	1000	100	H/V	0°..360°	--	>8.0	54.0

Remark: --

**g-Mode/6MBps/Channel 11**

Set-up No.:		2								
Operating Mode:		1								
Diagram no.	Frequency (MHz)	MaxPeak (dB $\mu$ V/m)	Meas . Time (ms)	Bandwidth (kHz)	Antenna height (cm)	Polarity	Turntable position (deg)	Corr. (dB) (C <sub>F</sub> )	Margin (dB) (M)	Limit (dB $\mu$ V/m) (L <sub>T</sub> )
8.06b	PK-detector									
	2800 - 18000	64.0	5	1000	100	H/V	0°..360°	--	>10.0	74.0
	AV-detector									
	2800 - 18000	51.0	5	1000	100	H/V	0°..360°	--	>4.0	54.0

Remark: --

**g-Mode/6MBps/Channel 11**

Set-up No.:		2								
Operating Mode:		1								
Diagram no.	Frequency (MHz)	MaxPeak (dB $\mu$ V/m)	Meas . Time (ms)	Bandwidth (kHz)	Antenna height (cm)	Polarity	Turntable position (deg)	Corr. (dB) (C <sub>F</sub> )	Margin (dB) (M)	Limit (dB $\mu$ V/m) (L <sub>T</sub> )
8.06c	PK-detector									
	18000 - 25000	< 67.17	5	1000	100	H/V	0°..360°	--	>6.66	74.0
	AV-detector									
	18000 - 25000	< 53.77	100	1000	100	H/V	0°..360°	--	--	54.0

Remark: overview measurement only -> no peaks discovered

**n-Mode/MCS0/Channel 1**

Set-up No.:		2								
Operating Mode:		1								
Diagram no.	Frequency (MHz)	MaxPeak (dB $\mu$ V/m)	Meas. Time (ms)	Bandwidth (kHz)	Antenna height (cm)	Polarity	Turntable position (deg)	Corr. (dB) (C <sub>F</sub> )	Margin (dB) (M)	Limit (dB $\mu$ V/m) (L <sub>T</sub> )
8.07a	PK-detector									
	1000 - 2800	60.0	5	1000	100	H/V	0°..360°	--	>14.0	74.0
	AV-detector									
	1000 - 2800	46.0	5	1000	100	H/V	0°..360°	--	>8.0	54.0
8.07aa <sup>1)</sup>	2350-2420	49.4	100	1000	155	H	225	--	4.6	54.0

Remark: --

**n-Mode/MCS0/Channel 1**

Set-up No.:		2								
Operating Mode:		1								
Diagram no.	Frequency (MHz)	MaxPeak (dB $\mu$ V/m)	Meas. Time (ms)	Bandwidth (kHz)	Antenna height (cm)	Polarity	Turntable position (deg)	Corr. (dB) (C <sub>F</sub> )	Margin (dB) (M)	Limit (dB $\mu$ V/m) (L <sub>T</sub> )
8.07b	PK-detector									
	2800 - 18000	64.0	5	1000	100	H/V	0°..360°	--	>10.0	74.0
	AV-detector									
	2800 - 18000	51.0	5	1000	100	H/V	0°..360°	--	>4.0	54.0

Remark: --

**n-Mode/MCS0/Channel 1**

Set-up No.:		2								
Operating Mode:		1								
Diagram no.	Frequency (MHz)	MaxPeak (dB $\mu$ V/m)	Meas. Time (ms)	Bandwidth (kHz)	Antenna height (cm)	Polarity	Turntable position (deg)	Corr. (dB) (C <sub>F</sub> )	Margin (dB) (M)	Limit (dB $\mu$ V/m) (L <sub>T</sub> )
8.07c	PK-detector									
	18000 - 25000	< 68.65	5	1000	100	H/V	0°..360°	--	>6.66	74.0
	AV-detector									
	18000 - 25000	< 53.82	100	1000	100	H/V	0°..360°	--	--	54.0

Remark: overview measurement only -> no peaks discovered

**n-Mode/MCS0/Channel 7**

Set-up No.:		2								
Operating Mode:		1								
Diagram no.	Frequency (MHz)	MaxPeak (dB $\mu$ V/m)	Meas. Time (ms)	Bandwidth (kHz)	Antenna height (cm)	Polarity	Turntable position (deg)	Corr. (dB) (C <sub>F</sub> )	Margin (dB) (M)	Limit (dB $\mu$ V/m) (L <sub>T</sub> )
8.08a	PK-detector									
	1000 - 2800	60.0	5	1000	100	H/V	0°..360°	--	>14.0	74.0
	AV-detector									
	1000 - 2800	46.0	5	1000	100	H/V	0°..360°	--	>8.0	54.0

Remark: --

**n-Mode/MCS0/Channel 7**

Set-up No.:		2								
Operating Mode:		1								
Diagram no.	Frequency (MHz)	MaxPeak (dB $\mu$ V/m)	Meas. Time (ms)	Bandwidth (kHz)	Antenna height (cm)	Polarity	Turntable position (deg)	Corr. (dB) (C <sub>F</sub> )	Margin (dB) (M)	Limit (dB $\mu$ V/m) (L <sub>T</sub> )
8.08b	PK-detector									
	4884.0	49.8	100.0	1000.000	155.0	H	209.0	2.9	24.2	74.0
	7324.4	50.7	100.0	1000.000	155.0	H	224.0	10.4	23.3	
	9768.0	57.7	100.0	1000.000	155.0	V	311.0	13.8	--*	--*
	AV-detector									
	4884.0	45.0	100	1000	100	H	210	2.9	9.0	54.0
	7327.0	42.5	100	1000	100	H	224	10.4	11.5	
	9768.0	50.2	100	1000	100	V	299	13.8	--*	--*

Remark: \*.) General limit accord. §15.209 not applicable

**n-Mode/MCS0/Channel 7**

Set-up No.:		2								
Operating Mode:		1								
Diagram no.	Frequency (MHz)	MaxPeak (dB $\mu$ V/m)	Meas. Time (ms)	Bandwidth (kHz)	Antenna height (cm)	Polarity	Turntable position (deg)	Corr. (dB) (C <sub>F</sub> )	Margin (dB) (M)	Limit (dB $\mu$ V/m) (L <sub>T</sub> )
8.08c	PK-detector									
	18000 - 25000	< 67.20	5	1000	100	H/V	0°..360°	--	>6.66	74.0
	AV-detector									
	18000 - 25000	< 53.67	100	1000	100	H/V	0°..360°	--	--	54.0

Remark: overview measurement only -> no peaks discovered

**n-Mode/MCS0/Channel 11**

Set-up No.:		2								
Operating Mode:		1								
Diagram no.	Frequency (MHz)	MaxPeak (dB $\mu$ V/m)	Meas . Time (ms)	Bandwidth (kHz)	Antenna height (cm)	Polarity	Turntable position (deg)	Corr. (dB) (C <sub>F</sub> )	Margin (dB) (M)	Limit (dB $\mu$ V/m) (L <sub>T</sub> )
8.09a	PK-detector									
	2490	68.8	100	1000	155	H	0°..360°	--	>5.2	74.0
	AV-detector									
	1000 - 2800	46.0	5	1000	155	H	0°..360°	--	>8.0	54.0
	2488.5	61.7	100	1000	155	H	317°	--	-7.7 remark1	54.0
8.09aa <sup>1)</sup>	2490.5	49.9	100	1000	155	H	356°	--	4.1	54

Remark: --

**n-Mode/MCS0/Channel 11**

Set-up No.:		2								
Operating Mode:		1								
Diagram no.	Frequency (MHz)	MaxPeak (dB $\mu$ V/m)	Meas . Time (ms)	Bandwidth (kHz)	Antenna height (cm)	Polarity	Turntable position (deg)	Corr. (dB) (C <sub>F</sub> )	Margin (dB) (M)	Limit (dB $\mu$ V/m) (L <sub>T</sub> )
8.09b	PK-detector									
	4924.0	47.9	100.0	1000.000	155.0	H	138.0	3.1	26.1	74.0
	7387.0	52.4	100.0	1000.000	155.0	H	181.0	10.7	21.6	74.0
	9848.0	59.7	100.0	1000.000	155.0	V	45.0	14.0	--*	--*
	12264.0	56.1	100.0	1000.000	155.0	H	213.0	17.3	17.9	74.0
	AV-detector									
	4924.0	41.0	100.0	1000.000	155.0	H	142.0	3.1	13.0	54.0
	7385.4	44.9	100.0	1000.000	155.0	H	210.0	10.7	9.1	54.0
	9848.0	55.7	100.0	1000.000	155.0	V	45.0	14.0	--*	--*
	12309.4	41.9	100.0	1000.000	155.0	V	-4.0	17.4	12.1	54.0

Remark: \*.) General limit accord. §15.209 not applicable

**n-Mode/MCS0/Channel 11**

Set-up No.:		2								
Operating Mode:		1								
Diagram no.	Frequency (MHz)	MaxPeak (dB $\mu$ V/m)	Meas. Time (ms)	Bandwidth (kHz)	Antenna height (cm)	Polarity	Turntable position (deg)	Corr. (dB) (C <sub>F</sub> )	Margin (dB) (M)	Limit (dB $\mu$ V/m) (L <sub>T</sub> )
8.09c	PK-detector									
	18000 - 25000	< 68.16	5	1000	100	H/V	0°..360°	--	>6.66	74.0
	AV-detector									
	18000 - 25000	< 53.80	100	1000	100	H/V	0°..360°	--	--	54.0

Remark: overview measurement only -> no peaks discovered

**5.9.2. Results for Intermodulation in TX-Mode (WLAN and GSM 850 simultaneous operating mode)**

**b-Mode: 1Mbps-Ch11/G850: GMSK**

Set-up No.:		2								
Operating Mode:		1+GSM850								
Diagram no.	Frequency (MHz)	MaxPeak (dB $\mu$ V/m)	Meas. Time (ms)	Bandwidth (kHz)	Antenna height (cm)	Polarity	Turntable position (deg)	Corr. (dB) (C <sub>F</sub> )	Margin (dB) (M)	Limit (dB $\mu$ V/m) (L <sub>T</sub> )
2.01e	PK-detector									
	1.6732	54.91	5	1000	155	H/V	0°..360°	--	19.08	74.0
	1000..2800	60.5	5	1000	155	H/V	0°..360°	--	13.5	74.0
	AV-detector									
	1673.2	41.14	5	1000	155	H/V	0°..360°	--	12.86	54.0
	2509.6	47.36	5	1000	155	H/V	0°..360°	--	6.64	54.0

Remark: \*) General limit accord. §15.209 not applicable

**b-Mode: 1Mbps-Ch11/G850: GMSK**

Set-up No.:		2								
Operating Mode:		1+GSM850								
Diagram no.	Frequency (MHz)	MaxPeak (dB $\mu$ V/m)	Meas. Time (ms)	Bandwidth (kHz)	Antenna height (cm)	Polarity	Turntable position (deg)	Corr. (dB) (C <sub>F</sub> )	Margin (dB) (M)	Limit (dB $\mu$ V/m) (L <sub>T</sub> )
2.02e	PK-detector									
	2800-18000	64.0	5.0	1000.0	155.0	H/V	0°..360°	--	10.0	74.0
	AV-detector									
	4923.9	34.9	100.0	1000.0	155.0	H	142.0	3.1	19.1	74.0
	9847.9	43.8	100.0	1000.0	155.0	H	207.0	14.0	--*	--*

Remark: \*) General limit accord. §15.209 not applicable

**5.9.3. Results for TX-Mode (WLAN and GSM 1900 operating mode)**

**g-Mode: 6Mbps-Ch11/PCS1900: GMSK**

Set-up No.:		2								
Operating Mode:		1+GSM1900								
Diagram no.	Frequency (MHz)	MaxPeak (dB $\mu$ V/m)	Meas Time (ms)	Bandwidth (kHz)	Antenna height (cm)	Polarity	Turntable position (deg)	Corr. (dB) (C <sub>F</sub> )	Margin (dB) (M)	Limit (dB $\mu$ V/m) (L <sub>T</sub> )
2.05e	PK-detector									
	1000-2800	<59.0	5.0	1000.0	155.0	H/V	0°..360°	--	>15.0	74.0
	AV-detector									
	1000-2800	<46.0	5.0	1000.0	155.0	H/V	0°..360°	--	>8.0	54.0

Remark: Carrier GSM and WLAN on diagram

**g-Mode: 6Mbps-Ch11/PCS1900: GMSK**

Set-up No.:		2								
Operating Mode:		1+GSM1900								
Diagram no.	Frequency (MHz)	MaxPeak (dB $\mu$ V/m)	Meas Time (ms)	Bandwidth (kHz)	Antenna height (cm)	Polarity	Turntable position (deg)	Corr. (dB) (C <sub>F</sub> )	Margin (dB) (M)	Limit (dB $\mu$ V/m) (L <sub>T</sub> )
2.06e	PK-detector									
	3759.9	59.2	100.0	1000.000	155.0	V	201.0	-0.1	14.80	74.0
	AV-detector									
	3759.9	39.5	100.0	1000.000	155.0	H	11.0	-0.1	14.50	54.0

Remark: --

**5.9.4. Results for TX-Mode (WLAN and FDD II operating mode)**

**n-Mode: MCS0-Channel 11/FDDII: U-ARFCN 9262**

Set-up No.:		2								
Operating Mode:		1+W-CDMA Band II								
Diagram no.	Frequency (MHz)	MaxPeak (dB $\mu$ V/m)	Meas Time (ms)	Bandwidth (kHz)	Antenna height (cm)	Polarity	Turntable position (deg)	Corr. (dB) (C <sub>F</sub> )	Margin (dB) (M)	Limit (dB $\mu$ V/m) (L <sub>T</sub> )
2.11e	PK-detector									
	1000-2800	<60.0	5.0	1000.0	155.0	H/V	0°..360°	--	>14.0	74.0
	AV-detector									
	1000-2800	<46.5	5.0	1000.0	155.0	H/V	0°..360°	--	>7.5	54.0

Remark: \*) General limit accord. §15.209 not applicable

**n-Mode: MCS0-Channel 11/FDDII: U-ARFCN 9262**

Set-up No.:		2								
Operating Mode:		1 + W-CDMA Band II								
Diagram no.	Frequency (MHz)	MaxPeak (dB $\mu$ V/m)	Meas Time (ms)	Bandwidth (kHz)	Antenna height (cm)	Polarity	Turntable position (deg)	Corr. (dB) (C <sub>F</sub> )	Margin (dB) (M)	Limit (dB $\mu$ V/m) (L <sub>T</sub> )
2.12e	PK-detector									
	3703.3	44.1	100.0	1000.000	155.0	V	164.0	-0.2	29.90	74.0
	AV-detector									
	3706.4	33.9	100.0	1000.000	155.0	V	163.0	-0.2	20.10	54.0

Remark: --

**5.9.5. Results for TX-Mode (WLAN, BT and FDD V operating mode)**

**b-Mode: 1Mbps-Channel 11/FDD V: U-ARFCN 4182**

Set-up No.:		2								
Operating Mode:		1 + W-CDMA Band V								
Diagram no.	Frequency (MHz)	MaxPeak (dB $\mu$ V/m)	Meas Time (ms)	Bandwidth (kHz)	Antenna height (cm)	Polarity	Turntable position (deg)	Corr. (dB) (C <sub>F</sub> )	Margin (dB) (M)	Limit (dB $\mu$ V/m) (L <sub>T</sub> )
2.15e	PK-detector									
	1000-2800	<60.0	5.0	1000.0	155.0	H/V	0°..360°	--	>14.0	74.0
	AV-detector									
	1000-2800	<46.5	5.0	1000.0	155.0	H/V	0°..360°	--	>7.5	54.0

Remark: --

**b-Mode: 1Mbps-Channel 11/FDD V: U-ARFCN 4182**

Set-up No.:		2								
Operating Mode:		1 + W-CDMA Band V								
Diagram no.	Frequency (MHz)	MaxPeak (dB $\mu$ V/m)	Meas Time (ms)	Bandwidth (kHz)	Antenna height (cm)	Polarity	Turntable position (deg)	Corr. (dB) (C <sub>F</sub> )	Margin (dB) (M)	Limit (dB $\mu$ V/m) (L <sub>T</sub> )
2.16e	PK-detector									
	4823.90	44.7	100.0	1000.000	155.0	H	137.0	2.7	29.3	74.0
	AV-detector									
	4823.90	36.0	100.0	1000.000	155.0	H	139.0	2.7	18.0	54.0
	9647.90	45.5	100.0	1000.000	155.0	V	315.0	13.6	--*	--*

Remark: \*) General limit accord. §15.209 not applicable



**5.9.6. RESULTS FOR RX-MODE (WLAN RX MODE)**

**b-Mode/1Mbps/Channel 11**

Set-up No.:		3								
Operating Mode:		3+5								
Diagram no.	Frequency (MHz)	MaxPeak (dBµV/m)	Meas Time (ms)	Bandwidth (kHz)	Antenna height (cm)	Polarity	Turntable position (deg)	Corr. (dB) (C <sub>F</sub> )	Margin (dB) (M)	Limit (dBµV/m) (L <sub>T</sub> )
2.01	PK-detector									
	1000 – 2800	< 46.0	5	1000	100	H/V	0°..360°	--	>20	74.0
	AV-detector									
	1000 – 2800	< 32.0	100	1000	100	H/V	0°..360°	--	--	54.0

Remark: --

**b-Mode/1Mbps/Channel 11**

Set-up No.:		3								
Operating Mode:		3+5								
Diagram no.	Frequency (MHz)	MaxPeak (dBµV/m)	Meas Time (ms)	Bandwidth (kHz)	Antenna height (cm)	Polarity	Turntable position (deg)	Corr. (dB) (C <sub>F</sub> )	Margin (dB) (M)	Limit (dBµV/m) (L <sub>T</sub> )
2.02	PK-detector									
	2800 – 18000	< 64.0	100.0	1000.000	155.0	H	0°..360°	--	> 10	74.0
	AV-detector									
	2800 – 18000	< 51.0	100.0	1000.000	155.0	H	0°..360°	--	> 3.0	54.0

Remark: --

<p><b>Margin to Limit:</b></p> $M = L_T - R_R + C_F + D_F$ $= L_T - R_R + (AF_{ANTENNA} + Cable_{LOSS}) + D_F$ <p>Remark: positive margin means passed result</p>	<p><b>Abbreviations used:</b></p> <ul style="list-style-type: none"> <li>• R<sub>R</sub> : Receiver readings in dBµV/m</li> <li>• C<sub>F</sub>: Transducer in dB = AF (antenna factor) + CL (cable loss)</li> <li>• D<sub>F</sub> : distance correction factor (if different measurement distance used than specified in the standard)</li> <li>• L<sub>T</sub> : Limit in dBµV/m</li> </ul>
---	---

**VERDICT**

Summary of measurement results for radiated emissions above 1 GHz: Passed

### 5.10. Carrier field strength and radiated band-edge compliance measurements

#### TEST LOCATION AND EQUIPMENT (for reference numbers please see chapter 'List of test equipment')

test location	<input checked="" type="checkbox"/> CETECOM Essen (Chapter. 2.2.1)	<input checked="" type="checkbox"/> 443 System CTC-FAR-EMI-	<input type="checkbox"/> Please see Chapter. 2.2.3
test site	<input type="checkbox"/> 441 EMI SAR	<input type="checkbox"/> 487 SAR NSA	<input type="checkbox"/> 337 OATS
antenna meas	<input checked="" type="checkbox"/> 549 HL025	<input type="checkbox"/> 289 CBL 6141	<input checked="" type="checkbox"/> 347 Radio.lab.
receiver	<input type="checkbox"/> 377 ESCS30	<input type="checkbox"/> 001 ESS	<input checked="" type="checkbox"/> 133 EMCO3115
spectr. analys.	<input type="checkbox"/> 489 ESU	<input type="checkbox"/> 120 FSEM	<input type="checkbox"/> 302 BBHA9170
power supply	<input type="checkbox"/> 456 EA 3013A	<input type="checkbox"/> 457 EA 3013A	<input type="checkbox"/> 477 GPS
otherwise	<input type="checkbox"/> 530 10dB Attenuator	<input type="checkbox"/> 459 EA 2032-50	<input type="checkbox"/> 268 EA- 3050
		<input type="checkbox"/> 494 AG6632A	<input type="checkbox"/> 498 NGPE 40
		<input type="checkbox"/> cable K15	

#### MEASUREMENT METHOD:

A Delta marker method was used for showing compliance to restricted bands according §15.205. The method is according Public Notice “Marker-Delta method”, Extract from DA00-705. The method consists of three independent steps:

1. Step: Prior to the measurement the fundamental radiated In-Band field strength was performed. The determined value is used as reference value.
2. Step: Second step consist of finding the relative attenuation between the fundamental emission and the maximum local out-of-band emission (within 2 MHz range around the band edge either on the band-edge directly or some modulation product if the level is greater than that on the band-edge) when measured with lower resolution bandwidth.
3. Step: The delta value recorded in step 2 will be subtracted from value recorded in step 1, thus giving the required field strength at the band-edge. This value must fulfil the requirements for radiated spurious emissions in restricted bands in §15.205 with the general limits of §15.209.

#### EUT SETTINGS:

For DTS systems the measurement was performed with different modulation, e.g. data rates to find worst-case.

### RESULTS

#### b-Mode

Set-up: 2				
Op. Mode: 1				
$T_{NOM} = 21^{\circ}C$ , $V_{NOM} = 3.7V$	Fundamental field strength-radiated	Delta Marker Value	Value at Band-Edge	Verdict
	[dBµV/m]	[dBc]	[dBµV/m]	
Channel Low	96.63 (AV)	41.08 > 20dBc	55.55(AV) > 20dBc	Passed
Channel High	91.05 (PK) 86.99 (AV)	42.61	48.44 (PK) 44.38 (AV)	Passed Passed

#### g-Mode

Set-up: 2				
Op. Mode: 1				
$T_{NOM} = 21^{\circ}C$ , $V_{NOM} = 3.7V$	Fundamental field strength-radiated	Delta Marker Value	Value at Band-Edge	Verdict
	[dBµV/m]	[dB]	[dBµV/m]	
Channel Low	88.32 (AV)	30.58 > 20dBc	57.74 (AV) >20dBc	Passed
Channel High	102.2 (PK) 90.10 (AV)	44.18	58.02 (PK) 45.92 (AV)	Passed Passed

**n-Mode**

Set-up: 2 Op. Mode: 1				
$T_{NOM} = 21^{\circ}C$ , $V_{NOM} = 3.7 V$	Fundamental field strength-radiated  [dB $\mu$ V/m]	Delta Marker Value  [dB]	Value at Band-Edge  [dB $\mu$ V/m]	Verdict
Channel Low	101.08 (AV)	28.11 > 20dBc	72.97 (>20dBc)	Passed
Channel High	98.72 (PK) 86.35 (AV)	42.77	55.95 (PK) 43.58 (AV)	Passed Passed

**VERDICT:** pass

### 5.11. Measurement uncertainties

The reported uncertainties are calculated based on the standard uncertainty multiplied with the appropriate coverage factor **k**, such that a confidence level of approximately 95% is achieved.

For uncertainty determination, each component used in the concrete measurement set-up was taken in account and it's contribution to the overall uncertainty according it's statistical distribution calculated.

Following table shows expectable uncertainties for each measurement type performed.

Measurement	Frequency range	Calculated uncertainty based on a confidence level of 95%	Remarks:
RF-Power Output conducted	9 kHz .. 20 GHz	1.0 dB	--
RF-Power Output radiated	30 MHz .. 4 GHz	3.17 dB	Substitution method
Conducted RF-emissions on antenna ports	9 kHz .. 20 GHz	1.0 dB	--
Radiated RF-emissions enclosure	150 kHz .. 30 MHz	5.0 dB	Magnetic field
	30 MHz .. 1 GHz	4.2 dB	E-Field
	1 GHz .. 18GHz	4.8 dB	E-Field
	1 GHz .. 20 GHz	3.17 dB	Substitution method
Occupied bandwidth	9 kHz .. 4 GHz	0.1272 ppm (Delta Marker method)	Frequency error
		1 dB	Power
Emission bandwidth	9 kHz .. 4 GHz	0.1272 ppm (Delta Marker method)	Frequency error
		1 dB	Power
Frequency stability	9 kHz .. 20 GHz	0.0636 ppm	--
Conducted emissions on AC-mains port (U <sub>CISPR</sub> )	9 kHz .. 150 kHz	4.0 dB	--
	150 kHz .. 30 MHz	3.6 dB	

**Table : measurement uncertainties, valid for conducted/radiated measurements**

## 6. Accreditation details of CETECOM’s laboratories and test sites

Ref.-No.	Accreditation Certificate	Valid for laboratory area or test site	Accreditation Body
-	D-PL-12047-01-01	All laboratories and test sites of CETECOM GmbH, Essen	DAkkS, Deutsche Akkreditierungsstelle GmbH
337 487 558 348 348	736496	Radiated Measurements 30 MHz to 1 GHz, 3m+10m OATS Radiated Measurements 30 MHz to 1 GHz, 3m SAR Radiated Measurements above 1 GHz, 3 m Fully Anechoic Chamber Mains Ports Conducted Interference Measurements Telecommunication Ports Conducted Interference Measurements	FCC, Federal Communications Commission Laboratory Division, USA (MRA US-EU 0003)
337 487 550 558	3462D-1 3462D-2 3462D-2 3462D-3	Radiated Measurements 30 MHz to 1 GHz, 3m + 10m OATS Radiated Measurements 30 MHz to 1 GHz, 3m SAR Radiated Measurements 1 GHz to 6 GHz, 3m SAR Radiated Measurements above 1 GHz ,3 m Fully Anechoic Chamber	IC, Industry Canada Certification and Engineering Bureau
337 487 550 348 348	R-2665 R-2666 G-301 C-2914 T-1967	Radiated Measurements 30 MHz to 1 GHz, 3m+10m OATS Radiated Measurements 30 MHz to 1GHz, 3m SAR Radiated Measurements 1GHz to 6 GHz, 3m SAR Mains Ports Conducted Interference Measurements Telecommunication Ports Conducted Interference Measurements	VCCI, Voluntary Control Council for Interference by Information Technology Equipment, Japan

## 7. Instruments and Ancillary

### 7.1. Used equipment “CTC”

The “Ref.-No” in the left column of the following tables allows the clear identification of the laboratory equipment.

#### 7.1.1. Test software and firmware of equipment

Ref.-No.	Equipment	Type	Serial-No.	Version of Firmware or Software during the test
001	Emi Test Receiver	ESS	825132/017	Firm.= 1.21 , OTP=2.0, GRA=2.0
012	Signal Generator (EMS-cond.)	SMY 01	839069/027	Firm.= V 2.02
013	Power Meter (EMS cond.)	NRVD	839111/003	Firm.= V 1.51
017	Digital Radiocommunication Tester	CMD 60 M	844365/014	Firmware = V 3.52 .22.01.99, DECT = D2.87 13.01.99
053	Audio Analyzer	UPA3	860612/022	Firm. V 4,3
119	RT Harmonics Analyzer dig. Flickermeter	B10	G60547	Firm.= V 3.1DHG
140	Signal Generator	SMHU	831314/006	Firm.= 3.21
261	Thermal Power Sensor	NRV-Z55	825083/0008	EPROM-Datum 02.12.04, SE EE 1 B
262	Power Meter	NRV-S	825770/0010	Firm.= 2.6
263	Signal Generator	SMP 04	826190/0007	Firm.=3.21
264	Spectrum Analyzer	FSEK 30	826939/005	Bios=2.1, Analyzer= 3.20
295	Racal Digital Radio Test Set	6103	1572	UNIT Firmware= 4.04, SW-Main=4.04, SW-BBP=1.04, SW-DSP=1.02, Hardboot=1.02, Softboot=2.02
298	Univ. Radio Communication Tester	CMU 200	832221/091	R&S Test Firmware =3.53 /3.54 (current Testsoftw. f. all band used
323	Digital Radiocommunication Tester	CMD 55	825878/0034	Firm.= 3.52 .22.01.99
331	Climatic Test Chamber -40/+80 Grad	HC 4055	43146	TSI 1.53
335	System-CTC-EMS-Conducted	System EMS Conducted	-	EMC 32 V 8.40
340	Digital Radiocommunication Tester	CMD 55	849709/037	Firm.= 3.52 .22.01.99
355	Power Meter	URV 5	891310/027	Firm.= 1.31
365	10V Insertion Unit 50 Ohm	URV5-Z2	100880	Eprom Data = 31.03.08
366	Ultra Compact Simulator	UCS 500 M4	V0531100594	Firm. UCS 500=001925/3.06a02, rc=ISMIEC 4.10
371	Bluetooth Tester	CBT32	100153	CBT V5.30+ SW-Option K55
377	Emi Test Receiver	ESCS 30	100160	Firm.= 2.30, OTP= 02.01, GRA= 02.36
378	Broadband RF Field Monitor	RadiSense III	03D00013SNO-08	Firm.= V.03D13
383	Signal Generator	SME 03	842 828 /034	Firm.= 4.61
389	Digital Multimeter	Keithley 2000	0583926	Firm. = A13 (Mainboard) A02 (Display)
392	Radio Communication Tester	MT8820A	6K00000788	Firm.= 4.50 #005, IPL=4.01#001,OS=4.02#001, GSM=4.41#013, W-CDMA= 4.54#004, scenario= 4.52#002
436	Univ. Radio Communication Tester	CMU 200	103083	R&S Test Firmware Base=5.14, Mess-Software= GSM:5.14 WCDMA:5.14 (current Testsoftw. F. all band to be used ,
441	CTC-SAR-EMI Cable Loss	System EMI field (SAR) Cable	-	EMC 32 Version 8.40
442	CTC-SAR-EMS	System EMS field (SAR)	-	EMC 32 Version 8.40
443	CTC-FAR-EMI-RSE	System CTC-FAR-EMI-RSE	-	Spuri 7.2.5 or EMC 32 Ver. 8.40
444	CTC-FAR-EMS field	System-EMS-Field (FAR)	-	EMC 32 Version 8.40
460	Univ. Radio Communication Tester	CMU 200	108901	R&S Test Firmware Base=5.14, GSM=5.14 WCDMA=5.14 (current Testsoftw.,f. all band to be used,
489	Emi Test Receiver	ESU40	1000-30	Firmware=4.43 SP3, Bios=V5.1-16-3, Spec. =01.00
491	ESD Simulator dito	ESD dito	dito307022	V 2.30
524	Voltage Drop Simulator	VDS 200	0196-16	Software Nr. 000037 Version V4.20a01
526	Burst Generator	EFT 200 A	0496-06	Software Nr. 000034 Version V2.32
527	Micro Pulse Generator	MPG 200 B	0496-05	Software-Nr. 000030 Version V2.43
528	Load Dump Simulator	LD 200B	0496-06	Software-Nr. 000031 Version V2.35a01
546	Univ. Radio Communication Tester	CMU 200	106436	R&S Test Firmware Base=5.14, GSM=5.14 WCDMA=5.14 (current Testsoftw.,f. all band to be used
547	Univ. Radio Communication Tester	CMU 200	835390/014	R&S Test Firmware Base=V5.1403 (current Testsoftw., f. all band used, GSM = 5.14 WCDMA: = 5.14
584	Spectrum Analyzer	FSU 8	100248	2.82_SP3
594	Univ. Radio Communication Tester	CMW500	101757	Firmware Base=2.0.20.9, LTE=2.0.20.8. CDMA= 2.0.10
597	Univ. Radio Communication Tester	CMU 200	100347	R&S Test Firmware Base=5.01, GSM=5.02 WCDMA= not installed, Mainboard= µP1=V.850
598	Spectrum Analyzer	FSEM 30 (Reserve)	831259/013	Firmware Bios 3.40 , Analyzer 3.40 Sp 2

7.1.2. Single instruments and test systems

Ref.-No.	Equipment	Type	Serial-No.	Manufacturer	Interval of calibration	Remark	Cal due
001	Emi Test Receiver	ESS	825132/017	Rohde & Schwarz	12 M	-	31.03.2012
005	AC - LISN (50 Ohm/50µH, test site 1)	ESH2-Z5	861741/005	Rohde & Schwarz	24/12 M	-	31.03.2012
007	DC - LISN (50 Ohm/5µH)	ESH3-Z6	892563/002	Rohde & Schwarz	24/12 M	-	31.03.2012
009	Power Meter (EMS-radiated)	NRV	863056/017	Rohde & Schwarz	24 M	-	31.03.2013
016	Line Impedance Simulating Network	Op. 24-D	B6366	Spitzenberger+Spies	36 M	-	31.03.2013
020	Horn Antenna 18 GHz (Subst 1)	3115	9107-3699	EMCO	36/12 M	-	31.03.2013
021	Loop Antenna (H-Field)	6502	9206-2770	EMCO	36 M	-	31.03.2013
030	Loop Antenna (H-field)	HFH-Z2	879604/026	Rohde & Schwarz	36 M	-	31.03.2012
033	RF-current probe (100kHz-30MHz)	ESH2-Z1	879581/18	Rohde & Schwarz	24 M	-	31.03.2013
057	relay-switch-unit (EMS system)	RSU	494440/002	Rohde & Schwarz	pre-m	1a	
060	power amplifier (DC-2kHz)	PAS 5000	B6363	Spitzenberger+Spies	-	3	
066	notch filter (WCDMA; FDD1)	WRCT 1900/2200-5/40-10EEK	5	Wainwright GmbH	12 M	1c	30.06.2012
086	DC - power supply, 0 -10 A	LNG 50-10	-	Heinzinger Electronic	pre-m	2	
087	DC - power supply, 0 -5 A	EA-3013 S	-	Elektro Automatik	pre-m	2	
090	Helmholtz coil: 2x10 coils in series	-	-	RWTÜV	-	4	
091	USB-LWL-Converter	OLS-1	007/2006	Ing. Büro Scheiba	-	4	
099	passive voltage probe	ESH2-Z3	299.7810.52	Rohde & Schwarz	36 M	-	31.03.2012
100	passive voltage probe	Probe TK 9416	without	Schwarzbeck	36 M	-	31.03.2012
110	USB-LWL-Converter	OLS-1	-	Ing. Büro Scheiba	-	4	
119	RT Harmonics Analyzer dig. Flickermeter	B10	G60547	BOCONSULT	36 M	-	31.03.2013
134	horn antenna 18 GHz (Subst 2)	3115	9005-3414	EMCO	12 M	-	31.03.2012
136	adjustable dipole antenna (Dipole 1)	3121C-DB4	9105-0697	EMCO	12 M	-	31.03.2012
140	Signal Generator	SMHU	831314/006	Rohde & Schwarz	24 M	-	31.03.2012
248	attenuator	SMA 6dB 2W	-	Radiall	pre-m	2	
249	attenuator	SMA 10dB 10W	-	Radiall	pre-m	2	
252	attenuator	N 6dB 12W	-	Radiall	pre-m	2	
256	attenuator	SMA 3dB 2W	-	Radiall	pre-m	2	
257	hybrid	4031C	04491	Narda	pre-m	2	
260	hybrid coupler	4032C	11342	Narda	pre-m	2	
261	Thermal Power Sensor	NRV-Z55	825083/0008	Rohde & Schwarz	24/12 M	-	31.03.2012
262	Power Meter	NRV-S	825770/0010	Rohde & Schwarz	24 M	-	31.03.2012
263	Signal Generator	SMP 04	826190/0007	Rohde & Schwarz	36 M	-	31.03.2013
264	Spectrum Analyzer	FSEK 30	826939/005	Rohde & Schwarz	12 M	-	31.03.2014
265	peak power sensor	NRV-Z33, Model 04	840414/009	Rohde & Schwarz	24 M	-	31.03.2012
266	peak power sensor	NRV-Z31, Model 04	843383/016	Rohde & Schwarz	24 M	-	31.03.2012
267	notch filter GSM 850	WRCA 800/960-6EEK	9	Wainwright GmbH	pre-m	2	
268	AC/DC power supply	EA 3050-A	9823636	Elektro Automatik	pre-m	2	
270	termination	1418 N	BB6935	Weinschel	pre-m	2	
271	termination	1418 N	BE6384	Weinschel	pre-m	2	
272	attenuator (20 dB) 50 W	Model 47	BF6239	Weinschel	pre-m	2	
273	attenuator (10 dB) 100 W	Model 48	BF9229	Weinschel	pre-m	2	
274	attenuator (10 dB) 50 W	Model 47 (10 dB) 50 W	BG0321	Weinschel	pre-m	2	
275	DC-Block	Model 7003 (N)	C5129	Weinschel	pre-m	2	
276	DC-Block	Model 7006 (SMA)	C7061	Weinschel	pre-m	2	
279	power divider	1515 (SMA)	LH855	Weinschel	pre-m	2	
287	pre-amplifier 25MHz - 4GHz	AMF-2D-100M4G-35-10P	379418	Miteq	12 M	1c	30.06.2012
291	high pass filter GSM 850/900	WHJ 2200-4EE	14	Wainwright GmbH	12 M	1c	30.06.2012
298	Univ. Radio Communication Tester	CMU 200	832221/091	Rohde & Schwarz	pre-m	3	
300	AC LISN (50 Ohm/50µH, 1-phase)	ESH3-Z5	892 239/020	Rohde & Schwarz	24/12 M	-	31.03.2012
301	attenuator (20 dB) 50W, 18GHz	47-20-33	AW0272	Lucas Weinschel	pre-m	2	
302	horn antenna 40 GHz (Meas 1)	BBHA9170	155	Schwarzbeck	36 M	-	31.03.2014
303	horn antenna 40 GHz (Subst 1)	BBHA9170	156	Schwarzbeck	36 M	-	31.03.2014
331	Climatic Test Chamber -40/+80 Grad	HC 4055	43146	Heraeus Vötsch	24 M	-	30.11.2012
341	Digital Multimeter	Fluke 112	81650455	Fluke	24 M	-	31.03.2012
342	Digital Multimeter	Voltcraft M-4660A	IB 255466	Voltcraft	24 M	-	31.03.2013
347	laboratory site	radio lab.	-	-	-	5	
348	laboratory site	EMI conducted	-	-	-	5	
354	DC - Power Supply 40A	NGPE 40/40	448	Rohde & Schwarz	pre-m	2	
355	Power Meter	URV 5	891310/027	Rohde & Schwarz	24 M	-	31.03.2012
356	power sensor	NRV-Z1	882322/014	Rohde & Schwarz	24 M	-	31.03.2013
357	power sensor	NRV-Z1	861761/002	Rohde & Schwarz	24 M	-	31.03.2013
373	V-Network 5µH/50 Ohm	ESH3-Z6	100535	Rohde & Schwarz	24/12 M	-	31.03.2012
376	Horn Antenna 6 GHz	BBHA9120 E	BBHA 9120 E.179	Schwarzbeck	12 M	-	31.03.2012
377	Emi Test Receiver	ESCS 30	100160	Rohde & Schwarz	12 M	-	31.03.2012
389	Digital Multimeter	Keithley 2000	0583926	Keithley	24 M	-	31.03.2013
392	Radio Communication Tester	MT8820A	6K00000788	Anritsu	12 M	-	31.03.2012
431	Model 7405	Near-Field Probe Set	9305-2457	EMCO	-	4	
436	Univ. Radio Communication Tester	CMU 200	103083	Rohde & Schwarz	12 M	-	31.03.2012
441	CTC-SAR-EMI Cable Loss	System EMI field (SAR) Cable	-	CETECOM	12 M	5	31.08.2012

Ref.-No.	Equipment	Type	Serial-No.	Manufacturer	Interval of calibration	Remark	Cal due
443	CTC-FAR-EMI-RSE	System CTC-FAR-EMI-RSE	-	ETS-Lindgren/CETECOM	12 M	5	30.06.2012
448	notch filter WCDMA_FDD II	WRCT 1850.0/2170.0-5/40-10SSK	5	Wainwright Instruments GmbH	12 M	1c	30.06.2012
449	notch filter WCDMA FDD V	WRCT 824.0/894.0-5/40-8SSK	1	Wainwright	12 M	1c	30.06.2012
454	Oscilloscope	HM 205-3	9210 P 29661	Hameg	-	4	
456	DC-Power supply 0-5 A	EA 3013 S	207810	Elektro Automatik	pre-m	2	
459	DC -Power supply 0-5 A , 0-32 V	EA-PS 2032-50	910722	Elektro Automatik	pre-m	2	
460	Univ. Radio Communication Tester	CMU 200	108901	Rohde & Schwarz	12 M	-	31.03.2012
463	Universal source	HP3245A	2831A03472	Agilent	-	4	
466	Digital Multimeter	Fluke 112	89210157	Fluke USA	24 M	-	31.03.2012
467	Digital Multimeter	Fluke 112	89680306	Fluke USA	24 M	-	31.03.2012
468	Digital Multimeter	Fluke 112	90090455	Fluke USA	24 M	-	31.03.2012
477	ReRadiating GPS-System	AS-47	-	Automotive Cons. Fink	-	3	
480	power meter (Fula)	NRVS	838392/031	Rohde & Schwarz	24 M	-	31.03.2013
482	filter matrix	Filter matrix SAR 1	-	CETECOM (Brl)	-	1d	
484	pre-amplifier 2,5 - 18 GHz	AMF-5D-02501800-25-10P	1244554	Miteq	12 M	-	30.07.2012
487	System CTC NSA-Verification SAR-EMI	System EMI field (SAR) NSA	-	ETS Lindgren/CETECOM	12 M	-	30.09.2012
489	Emi Test Receiver	ESU40	1000-30	Rohde & Schwarz	12 M	-	31.03.2012
502	band reject filter	WRCG 1709/1786-1699/1796-	SN 9	Wainwright	pre-m	2	
503	band reject filter	WRCG 824/849-814/859-60/10SS	SN 5	Wainwright	pre-m	2	
512	notch filter GSM 850	WRCA 800/960-02/40-6EEK	SN 24	Wainwright	12 M	1c	30.06.2012
517	relais switch matrix	HF Relais Box Keithley System	SE 04	Keithley	pre-m	2	
523	Digital Multimeter	L4411A	MY46000154	Agilent	24 M	-	31.03.2013
529	6 dB Broadband resistive power divider	Model 1515	LH 855	Weinschel	pre-m	2	
530	10 dB Broadband resistive power divider	R 416110000	LOT 9828	-	pre-m	2	
546	Univ. Radio Communication Tester	CMU 200	106436	R&S	12 M	-	31.03.2012
547	Univ. Radio Communication Tester	CMU 200	835390/014	Rohde & Schwarz	12 M	-	31.03.2012
548	Digital-Barometer	GBP 2300	without	Greisinger GmbH	36/12 M	-	31.03.2012
549	Log.Per-Antenna	HL025	1000060	Rohde & Schwarz	36/12 M	-	31.03.2012
552	high pass filter 2,8-18GHz	WHKX 2.8/18G-10SS	4	Wainwright	12 M	1c	30.07.2012
558	System CTC FAR S-VSWR	System CTC FAR S-VSWR	-	CTC	24 M	-	31.07.2013
574	Biconilog Hybrid Antenna	BTA-L	980026L	Frankonia	36/12 M	-	30.03.2013
584	Spectrum Analyzer	FSU 8	100248	Rohde & Schwarz	12 M	-	31.03.2012
594	Univ. Radio Communication Tester	CMW500	101757	Rohde & Schwarz	24 M	-	31.03.2012
597	Univ. Radio Communication Tester	CMU 200	100347	Rohde & Schwarz	12 M	-	31.03.2012
598	Spectrum Analyzer	FSEM 30 (Reserve)	831259/013	Rohde & Schwarz	24 M	-	13.01.2013
600	power meter	NRVD (Reserve)	834501/018	Rohde & Schwarz	24 M	-	31.03.2013
601	medium-sensitivity diode sensor	NRV-Z5 (Reserve)	8435323/003	Rohde & Schwarz	24 M	-	12.01.2013
602	peak power sensor	NRV-Z32 (Reserve)	835080	Rohde & Schwarz	24 M	-	12.01.2013
608	UltraLog-Antenna	HL 562	830547/009	Rohde & Schwarz	36/12 M	-	31.03.2014
611	DC power supply	E3632A	KR 75305854	Agilent	pre-m	2	
612	DC power supply	E3632A	MY 40001321	Agilent	pre-m	2	
613	Attenuator	R416120000 20dB 10W	Lot. 9828	Radiall	pre-m	2	

**7.1.3. Legend**

Note / remarks		Calibrated during system calibration:
	1a	System CTC-SAR-EMS (Ref.-No. 442)
	1b	System-CTC-EMS-Conducted (Ref.-No. 335)
	1c	System CTC-FAR-EMI-RSE (Ref.-No . 443)
	1d	System CTC-SAR-EMI (Ref.-No . 441)
	1e	System CTC-OATS (EMI radiated) (Ref.-No. 337)
	1 f	System CTC-CTIA-OTA (Ref.-No . 420)
	1 g	System CTC-FAR-EMS (Ref.-No . 444)
	2	Calibration or equipment check immediately before measurement
	3	Regulatory maintained equipment for functional check or support purpose
	4	Ancillary equipment without calibration e.g. mechanical equipment or monitoring equipment
	5	Test System

Interval of calibration	12 M	12 month
-------------------------	------	----------



	24 M	24 month
	36 M	36 month
	24/12 M	Calibration every 24 months, between this every 12 months internal validation
	36/12 M	Calibration every 36 months, between this every 12 months internal validation
	Pre-m	Check before starting the measurement
	-	Without calibration

