

# EMI Test Report

Tested in accordance with  
Federal Communications Commission (FCC)  
Personal Communications Services  
CFR 47 Parts 2, 22, 24 and 27  
&  
Industry Canada (IC) RSS- Gen, 132, 133 and 139




**A division of Research In Motion Limited**

**REPORT NO: RTS-3933-1105-43B\_Rev1**

This report supersedes the report RTS-3933-1105-43B dated 19 June, 2011.

<b>PRODUCT MODEL NO:</b>	RDU71CW, RDV71UW
<b>TYPE NAME:</b>	BlackBerry® smartphone
<b>FCC ID:</b>	L6ARDU70CW, L6ARDV70UW
<b>IC:</b>	2503A-RDU70CW, 2503A-RDV70UW
<b>EMISSION DESIGNATOR (GSM):</b>	247KGXW
<b>EMISSION DESIGNATOR (EDGE):</b>	247KG7W
<b>EMISSION DESIGNATOR: (WCDMA):</b>	4M17F9W

**DATE:** 9 August 2011

	EMI Test Report for the BlackBerry® smartphone Model RDU71CW,RDV71UW	
<b>Test Report No.</b> RTS-3933-1105-43B_Rev1	<b>Dates of Test</b> Feb 7 to March 22, May 6 to May 31 and June 19, 2011	<b>FCC ID:</b> L6ARDU70CW <b>IC:</b> 2503A-RDU70CW <b>FCC ID:</b> L6ARDV70UW <b>IC:</b> 2503A-RDV70UW

**Report Revision History:**

Rev1:

1. Editorial changes in the header.
2. The associated documents update in section B.
3. Test Results chart update in section F

**Statement of Performance:**

The BlackBerry® smartphone, model RDU71CW, part number CER-32268-001 Rev 4 and accessories performs within the requirements of the test standards when configured and operated per RIM's instructions.

The BlackBerry® smartphone, model RDV71UW, part number CER-39235-001 Rev 2 and accessories performs within the requirements of the test standards when configured and operated per RIM's instructions.

**Declaration:**

We hereby certify that:

The test data reported herein is an accurate record of the performance of the sample(s) tested. The test results are valid for the tested unit (s) only. The test equipment used was suitable for the tests performed and within manufacturer's published specifications and operating parameters. The test methods were consistent with the methods described in the relevant standards.

Documented by:




Nielven Jay Olis  
Regulatory Compliance Specialist  
Date: August 9, 2011

Reviewed and Approved by:




Masud S. Attayi, P.Eng.  
Manager, Regulatory Compliance  
Date: August 9, 2011

	EMI Test Report for the BlackBerry® smartphone Model RDU71CW,RDV71UW	
<b>Test Report No.</b> RTS-3933-1105-43B_Rev1	<b>Dates of Test</b> Feb 7 to March 22, May 6 to May 31 and June 19, 2011	<b>FCC ID:</b> L6ARDU70CW <b>IC:</b> 2503A-RDU70CW <b>FCC ID:</b> L6ARDV70UW <b>IC:</b> 2503A-RDV70UW

## Table of Contents

A) Scope .....	5
B) Associated Documents .....	5
C) Product Identification .....	5
D) Support Equipment Used for the Testing of the EUT .....	8
E) Test Voltage .....	8
F) Test Results Chart.....	9
G) Summary of Results .....	11
H) Compliance Test Equipment Used .....	16
APPENDIX 1A – GSM CONDUCTED RF EMISSIONS TEST DATA/PLOTS.....	18
APPENDIX 1B – CDMA CONDUCTED RF EMISSIONS TEST DATA/PLOTS .....	35
APPENDIX 1C– UMTS CONDUCTED RF EMISSIONS TEST DATA/PLOTS.....	51
APPENDIX 2A – GSM CONDUCTED RF OUTPUT POWER TEST DATA.....	61

	EMI Test Report for the BlackBerry® smartphone Model RDU71CW,RDV71UW	
<b>Test Report No.</b> RTS-3933-1105-43B_Rev1	<b>Dates of Test</b> Feb 7 to March 22, May 6 to May 31 and June 19, 2011	<b>FCC ID:</b> L6ARDU70CW <b>IC:</b> 2503A-RDU70CW <b>FCC ID:</b> L6ARDV70UW <b>IC:</b> 2503A-RDV70UW

APPENDIX 2B – CDMA CONDUCTED RF OUTPUT POWER TEST DATA..... 63

APPENDIX 2C – UMTS CONDUCTED RF OUTPUT POWER TEST DATA..... 65


APPENDIX 3A – GSM FREQUENCY STABILITY TEST DATA ..... 67

APPENDIX 3B – CDMA FREQUENCY STABILITY TEST DATA ..... 79

APPENDIX 3C – UMTS FREQUENCY STABILITY TEST DATA ..... 92

APPENDIX 4A – CDMA RADIATED EMISSIONS TEST DATA ..... 100

APPENDIX 4B – UMTS RADIATED EMISSIONS TEST DATA..... 107

	EMI Test Report for the BlackBerry® smartphone Model RDU71CW,RDV71UW	
<b>Test Report No.</b> RTS-3933-1105-43B_Rev1	<b>Dates of Test</b> Feb 7 to March 22, May 6 to May 31 and June 19, 2011	<b>FCC ID:</b> L6ARDU70CW <b>IC:</b> 2503A-RDU70CW <b>FCC ID:</b> L6ARDV70UW <b>IC:</b> 2503A-RDV70UW

## A) Scope

This report details the results of compliance tests which were performed in accordance to the requirements of:


- FCC CFR 47 Part 2, Oct, 2010
- FCC CFR 47 Part 22, Subpart H, Cellular Radiotelephone Services, Oct, 2010
- FCC CFR 47 Part 24, Subpart E, Broadband PCS, Oct, 2010
- FCC CFR 47 Part 27, Subpart C, Technical Standards, Oct, 2010
- Industry Canada, RSS-132 Issue 2, September 2005, Cellular Telephones Employing New Technologies Operating in the Bands 824-849 MHz and 869-894 MHz.
- Industry Canada, RSS-133 Issue 5, February 2009, 2 GHz Personal Communications Services.
- Industry Canada, RSS-GEN Issue 3, December 2010, General Requirements and Information for the Certification of Radiocommunication Equipment
- Industry Canada, RSS-139 Issue 2, February 2009, Advanced Wireless Services Equipment Operating in the Bands 1710-1755 MHz and 2110-2155 MHz.

## B) Associated Documents

1. RDU71CW\_HW\_Declaration\_CER-32268\_Rev3.docx
2. RDU71CW\_HW\_Declaration\_CER-32268\_Rev4.docx
3. RDV71UW\_HW\_Declaration\_CER-39235\_Rev2.docx
4. BlackBerrySystemSimilarity\_RDU71CW\_RDV71UW.docx
5. MultiSourceDeclaration\_RDU71CW\_b260.docx
6. MultiSourceDeclaration\_RDU71CW\_b421.docx
7. MultiSourceDeclaration\_RDU71CW\_b677.docx
8. MultiSourceDeclaration\_RDU71CW\_b825.docx
9. MultiSourceDeclaration\_RDU71CW\_b984.docx
10. Test Report 1-3016-01-02\_11B
11. Test Report 1-3439-01-02\_11C

## C) Product Identification

Manufactured by Research In Motion Limited whose headquarters is located at:  
295 Phillip Street  
Waterloo, Ontario  
Canada, N2L 3W8  
Phone: 519 888 7465  
Fax: 519 888 6906


	EMI Test Report for the BlackBerry® smartphone Model RDU71CW,RDV71UW	
<b>Test Report No.</b> RTS-3933-1105-43B_Rev1	<b>Dates of Test</b> Feb 7 to March 22, May 6 to May 31 and June 19, 2011	<b>FCC ID:</b> L6ARDU70CW <b>IC:</b> 2503A-RDU70CW <b>FCC ID:</b> L6ARDV70UW <b>IC:</b> 2503A-RDV70UW

The equipment under test (EUT) was tested at the following locations:

RIM Testing Services EMI test facilities

305 Phillip Street	440 Phillip Street
Waterloo, Ontario	Waterloo, Ontario,
Canada, N2L 3W8	Canada , N2L 5R9
Phone: 519 888 7465	Phone: 519 888 7465
Fax: 519 888 6906	Fax: 519 888 6906

The testing was performed from Feb 7 to March 22, May 6 to May 24 and June 19, 2011.

	EMI Test Report for the BlackBerry® smartphone Model RDU71CW,RDV71UW	
<b>Test Report No.</b> RTS-3933-1105-43B_Rev1	<b>Dates of Test</b> Feb 7 to March 22, May 6 to May 31 and June 19, 2011	<b>FCC ID:</b> L6ARDU70CW <b>IC:</b> 2503A-RDU70CW <b>FCC ID:</b> L6ARDV70UW <b>IC:</b> 2503A-RDV70UW

The sample EUT included:

Sample	Model	CER NUMBER	PIN	Software Information
1	RDU71CW	CER-32268-001 Rev2	32D4BD42	V6.1.0.16 Bundle 157
2	RDU71CW	CER-32268-001 Rev2	32D4BD3C	V6.1.0.132 Bundle 677
3	RDU71CW	CER-32268-001 Rev4	32E8959A	V6.1.0.132 Bundle 677
4	RDU71CW	CER-32268-001 Rev4	32E895E2	V7.0.0.91 Bundle 825
5	RDU71CW	CER-32268-001 Rev2	32D4BDAC	V6.1.0.28 Bundle 260
6	RDV71UW	CER-39235-001 Rev 2	275502B4	V7.0.0.91 Bundle 825
7	RDV71UW	CER-39235-001 Rev1	2730A124	V7.0.0.144 Bundle 984
8	RDV71UW	CER-39235-001 Rev1	273081C5	V6.1.0.46 Bundle 421


RF Conducted Emissions testing was performed on sample 1 2, 3, 7 and 8.  
RF Radiated Emissions testing was performed on samples 4, 5 and 6

Only the characteristics that have been affected by the changes from Model RDU71CW Rev 2 to RDU71CW Rev 4 were retested. For more information see RDU71CW\_HW\_Declaration\_CER-32268\_Rev3.docx and RDU71CW\_HW\_Declaration\_CER-32268\_Rev4.docx

Only the characteristics that have been affected by the changes from Model RDV71UW Rev 1 to RDV71UW Rev 2 were retested. For more information see RDV71UW\_HW\_Declaration\_CER-39235\_Rev2.docx.

Only the characteristics that have been affected by the changes from Model RDU71CW to RDV71UW were retested. For more information see BlackBerrySystemSimilarity\_RDU71CW\_RDV71UW.docx

To view the differences between Bundle 157 to 984, see documents number:  
MultiSourceDeclaration\_ RDU71CW \_b260.docx  
MultiSourceDeclaration\_ RDU71CW \_b421.docx  
MultiSourceDeclaration\_ RDU71CW \_b677.docx  
MultiSourceDeclaration\_ RDU71CW \_b825.docx  
MultiSourceDeclaration\_ RDU71CW \_b984.docx

	EMI Test Report for the BlackBerry® smartphone Model RDU71CW,RDV71UW	
<b>Test Report No.</b> RTS-3933-1105-43B_Rev1	<b>Dates of Test</b> Feb 7 to March 22, May 6 to May 31 and June 19, 2011	<b>FCC ID:</b> L6ARDU70CW <b>IC:</b> 2503A-RDU70CW <b>FCC ID:</b> L6ARDV70UW <b>IC:</b> 2503A-RDV70UW

**D) Support Equipment Used for the Testing of the EUT**

No support equipment required; for list of equipment refer to section H, Compliance Test Equipment Used.

**E) Test Voltage**

The ac input voltage was 120 volts, 60 Hz where applicable. This configuration was per RIM's specifications.





**Test Report No.**  
RTS-3933-1105-43B\_Rev1

**Dates of Test**  
Feb 7 to March 22, May 6 to May 31 and  
June 19, 2011

**FCC ID:** L6ARDU70CW **IC:** 2503A-RDU70CW  
**FCC ID:** L6ARDV70UW **IC:** 2503A-RDV70UW

**F) Test Results Chart**

SPECIFICATION		TEST TYPE	RESULT	TEST DATA APPENDIX
FCC CFR 47	IC			
Part 2.1051 Part 22.917 Part 22.901	RSS-GEN, 4.9	GSM 850 Conducted Spurious Emissions	Pass	1A
Part 2.1051 Part 24.238(a)	RSS-GEN, 4.9	PCS 1900 Conducted Spurious Emissions	Pass	1A
Part 2.202 Part 22.917	RSS-GEN, 4.6	GSM 850 Occupied Bandwidth and Channel Mask	Pass	1A
Part 2.202 Part 24.238	RSS-GEN, 4.6	PCS 1900 Occupied Bandwidth and Channel Mask	Pass	1A
Part 2.1046(a)	RSS-133, 6.4 RSS-132, 4.4	GSM Conducted RF Output Power	Pass	2A
Part 2.1055(a)(d) Part 22.917	RSS-132, 4.3	GSM 850 Frequency Stability vs. Temperature and Voltage	Pass	3A
Part 2.1055(a)(d) Part 24.235	RSS-132, 4.3	PCS 1900 Frequency Stability vs. Temperature and Voltage	Pass	3A
Part 22, Subpart H, Part 24, Subpart E	RSS-GEN, 4.9	GSM ERP, EIRP	See test report 1-3016-01-02_11-B 1-3439-01-02_11-C	-
Part 22, Subpart H Part 24, Subpart E	RSS-GEN, 4.9	GSM Radiated Spurious/Harmonic Emissions	See test report 1-3016-01-02_11-B 1-3439-01-02_11-C	-
Part 2.1051 Part 22.917 Part 22.901(d)	RSS-GEN, 4.9	CDMA Cell Conducted Spurious Emissions	Pass	1B
Part 2.1051 Part 24.238(a)	RSS-GEN, 4.9	CDMA PCS Conducted Spurious Emissions	Pass	1B
Part 2.202 Part 22.917	RSS-GEN, 4.6	CDMA Cell Occupied Bandwidth and Channel Mask	Pass	1B
Part 2.202 Part 24.238	RSS-GEN, 4.6	CDMA PCS Occupied Bandwidth and Channel Mask	Pass	1B



EMI Test Report for the BlackBerry® smartphone Model RDU71CW,RDV71UW


**Test Report No.**  
RTS-3933-1105-43B\_Rev1

**Dates of Test**  
Feb 7 to March 22, May 6 to May 31 and  
June 19, 2011

**FCC ID:** L6ARDU70CW **IC:** 2503A-RDU70CW  
**FCC ID:** L6ARDV70UW **IC:** 2503A-RDV70UW

### Test Results Chart cont'd

Part 2.1046(a)	RSS-133, 6.4 RSS-132, 4.4	CDMA Conducted RF Output Power	Pass	2B
Part 2.1055(a)(d) Part 22.917	RSS-132, 4.3	CDMA Cell Frequency Stability vs. Temperature and Voltage	Pass	3B
Part 2.1055(a)(d) Part 24.235	RSS-GEN, 4.7	CDMA PCS Frequency Stability vs. Temperature and Voltage	Pass	3B
Part 22, Subpart H	RSS-GEN, 4.9	CDMA Cell Radiated Spurious/Harmonic Emissions, ERP	Pass	4A
Part 24, Subpart E	RSS-GEN, 4.9	CDMA PCS Radiated Spurious/Harmonic Emissions, EIRP	Pass	4A
Part 27.53	RSS-139, 6.5	UMTS band 4 Conducted Spurious Emissions	Pass	1C
Part 2.202 Part 27.53	RSS-GEN, 2.3	UMTS band 4 Occupied Bandwidth and Channel Mask	Pass	1C
Part 2.1046(a)	RSS-139, 6.4	UMTS band 4 Conducted RF Output Power	Pass	2C
Part 2.1055(a)(d) Part 27.54	RSS-139, 6.3	UMTS band 4 Frequency Stability vs. Temperature and Voltage	Pass	3C
Part 27.53	RSS-139, 6.5	UMTS band 4 Radiated Spurious/Harmonic Emissions	Pass	4C
Part 27.50	RSS-139, 6.4	UMTS band 4 EIRP	Pass	4C

	EMI Test Report for the BlackBerry® smartphone Model RDU71CW,RDV71UW	
<b>Test Report No.</b> RTS-3933-1105-43B_Rev1	<b>Dates of Test</b> Feb 7 to March 22, May 6 to May 31 and June 19, 2011	<b>FCC ID:</b> L6ARDU70CW <b>IC:</b> 2503A-RDU70CW <b>FCC ID:</b> L6ARDV70UW <b>IC:</b> 2503A-RDV70UW

## G) Summary of Results

The following test configurations were measured for model RDU71CW:

### 1) Conducted Emission Measurements

a) The BlackBerry® smartphone met the requirements of the Tx Conducted Spurious Emissions requirements in the GSM850 as per 47 CFR 2.1051, CFR 22.917, CFR 22.901(d) and RSS-GEN, 4.9. The EUT was measured on the low, middle and high channels. The frequency range investigated was from 10 MHz to 10 GHz.

See APPENDIX 1A for test data.

The BlackBerry® smartphone met the requirements of the Tx Conducted Spurious Emissions requirements in the PCS1900 as per 47 CFR 2.1051, CFR 24.238(a) and RSS-GEN, 4.9. The EUT was on the low, middle and high channels. The frequency range investigated was from 10 MHz to 20 GHz.

See APPENDIX 1A for test data

b) The BlackBerry® smartphone met the requirements of the Occupied Bandwidth and channel mask requirements in the GSM850 as per 47 CFR 2.202, CFR 22.917 and RSS-GEN, 4.6. The EUT was measured in GSM and EDGE mode on the low, middle and high channels. The worst case occupied bandwidth was 246.7 kHz on high channel in GSM mode, and 246.7 kHz on high channel in EDGE mode.

See APPENDIX 1A for test data.

The BlackBerry® smartphone met the requirements of the Occupied Bandwidth and channel mask requirements in the PCS1900 as per 47 CFR 2.202, CFR 24.238 and RSS-GEN, 4.6. The EUT was measured in GSM and EDGE mode on the low, middle and high channels. The worst case occupied bandwidth was 245.0 kHz on low channel in GSM, and 245.0 kHz on middle and high channel in EDGE mode.


See APPENDIX 1A for test data.

c) The BlackBerry® smartphone met the requirements of the Tx Conducted RF output Power requirements in the GSM850 as per 47 CFR 2.1046, and RSS-GEN, 4.4. The EUT was measured on the low, middle and high channels. The frequency range investigated was from 10 MHz to 10 GHz.

See APPENDIX 2A for test data.

The BlackBerry® smartphone met the requirements of the Tx Conducted RF output Power requirements in the PCS1900 as per 47 CFR 2.1046, and RSS-GEN, 6.4. The EUT was on the low, middle and high channels. The frequency range investigated was from 10 MHz to 20 GHz.

See APPENDIX 2A for test data

	EMI Test Report for the BlackBerry® smartphone Model RDU71CW,RDV71UW	
<b>Test Report No.</b> RTS-3933-1105-43B_Rev1	<b>Dates of Test</b> Feb 7 to March 22, May 6 to May 31 and June 19, 2011	<b>FCC ID:</b> L6ARDU70CW <b>IC:</b> 2503A-RDU70CW <b>FCC ID:</b> L6ARDV70UW <b>IC:</b> 2503A-RDV70UW

d) The BlackBerry® smartphone met the requirements of the Frequency Satbility requirements in the GSM850 as per 47 CFR 2.1055, CFR 22.917 and RSS-GEN, 4.3. The EUT was measured in GSM850 mode on the low, middle and high channels.  
See APPENDIX 3A for test data.

The BlackBerry® smartphone met the requirements of the Frequency Satbility requirements in the PCS1900 as per 47 CFR 2.1055, CFR 24.235 and RSS-GEN, 4.7. The EUT was measured in PCS1900 mode on the low, middle and high channels.  
See APPENDIX 3A for test data.


e) The EUT met the requirements of the Conducted Spurious Emissions in the Cellular band as per 47 CFR 22.917, CFR 22.901(d) and RSS-132. The EUT was measured in Loopback and 1xEVDO mode on the low, middle and high channels. The frequency range investigated was from 10 MHz to 10 GHz.  
See APPENDIX 1B for the test data.

The BlackBerry® smartphone met the requirements of the Conducted Spurious Emissions in the CDMA PCS band as per 47 CFR 2.1057, CFR 24.238 and RSS-133. The EUT was measured in Loopback and 1xEVDO mode on the low, middle and high channels. The frequency range investigated was from 10 MHz to 20 GHz  
See APPENDIX 1B for the test data.

f) The BlackBerry® smartphone met the requirements of the Occupied Bandwidth in the CDMA Cellular band as per 47 CFR 2.202, CFR 22.917 and RSS-132. The EUT was measured in Loopback and 1xEVDO mode on the low, middle and high channels. The worst case occupied bandwidth was 1.280 MHz on high channel in Loopback mode and 1.273 MHz on low and high channel in 1xEVDO mode.  
See APPENDIX 1B for the test data.

The BlackBerry® smartphone met the requirements of the Occupied Bandwidth and channel mask in the CDMA PCS band as per 47 CFR 2.202, CFR 24.238 and RSS-133. The EUT was measured in Loopback and 1xEVDO mode on the low, middle and high channels. The worst case occupied bandwidth was 1.280 MHz on middle channel in Loopback mode and 1.280 MHz on high channel in 1xEVDO mode..  
See APPENDIX 1B for the test data.

g) The BlackBerry® smartphone met the requirements of the Conducted RF Output Power for both the CDMA Cellular and PCS bands. The EUT was measured in Loopback and 1xEVDO mode on the low, middle and high channels

	EMI Test Report for the BlackBerry® smartphone Model RDU71CW,RDV71UW	
<b>Test Report No.</b> RTS-3933-1105-43B_Rev1	<b>Dates of Test</b> Feb 7 to March 22, May 6 to May 31 and June 19, 2011	<b>FCC ID:</b> L6ARDU70CW <b>IC:</b> 2503A-RDU70CW <b>FCC ID:</b> L6ARDV70UW <b>IC:</b> 2503A-RDV70UW

See APPENDIX 2B for test data.

h) The BlackBerry® smartphone met the requirements of the Frequency Stability vs. Temperature and Voltage for CDMA Cellular band as per 22.917 and RSS-132. The EUT was measured in Cellular mode on the low, middle and high channels. See APPENDIX 3B for test data.

The BlackBerry® smartphone met the requirements of the Frequency Stability vs. Temperature and Voltage requirements for the PCS band as per 24.235 and RSS-133. The EUT was measured in CDMA PCS mode on the low, middle and high channels.

See APPENDIX 3B for test data.


The following test configurations were measured for model RDV71UW:

i) The BlackBerry® smartphone met the requirements of the Conducted Spurious Emissions in the UMTS band 4 as per 47 CFR 27.53 and RSS-139, 6.5. The EUT was measured in Loopback and HSUPA mode on the low, middle and high channels. The frequency range investigated was from 10 MHz to 20 GHz. See APPENDIX 1C for the test data.

j) The BlackBerry® smartphone met the requirements of the Occupied Bandwidth in the UMTS band 4 as per 47 CFR 2.202, CFR 27.53 and RSS-139, 2.3. The EUT was measured in Loopback and HSUPA mode on the low, middle and high channels. The worst case 99% Occupied Bandwidth was 4.167 MHz. See APPENDIX 1C for the test data.

k) The BlackBerry® smartphone met the requirements of the Conducted RF Output Power for the UMTS band 4 as per 47 CFR 2.1046(a), RSS-139, 6.4 and RSS-132, 4.4. The EUT was measured on the low, middle and high channels. See APPENDIX 2C for test data.

l) The BlackBerry® smartphone met the requirements of the Frequency Stability vs. Temperature and Voltage for UMTS band 4 as per 47 CFR 2.1055(a)(d), CFR 27.54 and RSS-139, 6.3. The maximum frequency error measured was less than 0.1 ppm. The temperature range was from -30°C to +60°C in 10° temperature steps. The BlackBerry® smartphone was measured on low, middle and high channels at each temperature step. The BlackBerry® smartphone was measured at low (3.6 volts), nominal (3.7 volts) and high (4.2 volts) dc input voltage at each temperature step and channel at maximum output power. See APPENDIX 3C for test data.

	EMI Test Report for the BlackBerry® smartphone Model RDU71CW,RDV71UW	
<b>Test Report No.</b> RTS-3933-1105-43B_Rev1	<b>Dates of Test</b> Feb 7 to March 22, May 6 to May 31 and June 19, 2011	<b>FCC ID:</b> L6ARDU70CW <b>IC:</b> 2503A-RDU70CW <b>FCC ID:</b> L6ARDV70UW <b>IC:</b> 2503A-RDV70UW

## 2) Radiated Emission Measurements

### a) Radiated Spurious and Harmonic Emissions

The radiated spurious emissions/harmonics and ERP/EIRP were measured for CDMA Cellular and CDMA PCS. The results are within the limits. The BlackBerry® smartphone was placed on a nonconductive styrofoam table, 100 cm high that was positioned on a remotely controlled turntable. The test distance used between the BlackBerry® smartphone and the receiving antenna was three metres. Then the emissions were maximized by elevating the antenna in the range of 1 to 4 metres. The turntable was rotated to determine the azimuth of the peak emissions. Both the horizontal and vertical polarizations of the emissions were measured. The maximum emissions level was recorded. The BlackBerry® smartphone was then substituted with an antenna placed in the same location as the BlackBerry® smartphone. A Dipole antenna was used for the ERP measurements and a Horn antenna was used for EIRP measurements. The substitution antenna was connected into a signal generator that was set to the test frequency.

The emissions were maximized by elevating the antenna in the range of 1 to 4 metres. The signal generator output was then adjusted to match the BlackBerry® smartphone output reading. The signal generator output was recorded. Both the horizontal and vertical polarizations of the emissions were measured.

The following measurements were done in a semi-anechoic chamber (SAC) below 1 GHz and a Semi-anechoic Chamber ((SAC) with floor absorber) above 1 GHz. The SAC's FCC registration number is **778487** and the Industry Canada (IC) file number is **2503B-1**. The SAC with floor absorber's FCC registration number is **959115** and the IC file number is **2503C-1**. The BlackBerry® smartphone was measured on the low, middle and high channels.


The following test configurations were measured for model RDU71CW:

The highest ERP measured in the Cellular band, Loopback Service mode, was 28.72 dBm (0.75 W) at 836.52 MHz (channel 384).

The highest ERP measured in the Cellular band, 1xEVDO mode, was 26.38 dBm (0.44 W) at 836.52 MHz (channel 384).

The highest EIRP measured in the PCS band, Loopback Service mode, was 27.82 dBm (0.61 W) at 1880.00 MHz (channel 600).

The highest EIRP measured in the PCS band, 1xEVDO mode, was 31.1 dBm (1.29 W) at 1880.00 MHz (channel 600)

	EMI Test Report for the BlackBerry® smartphone Model RDU71CW,RDV71UW	
<b>Test Report No.</b> RTS-3933-1105-43B_Rev1	<b>Dates of Test</b> Feb 7 to March 22, May 6 to May 31 and June 19, 2011	<b>FCC ID:</b> L6ARDU70CW <b>IC:</b> 2503A-RDU70CW <b>FCC ID:</b> L6ARDV70UW <b>IC:</b> 2503A-RDV70UW

The radiated carrier harmonics were measured up to the 10<sup>th</sup> harmonic for low, middle and high channels in the Cellular and PCS. Each band was measured in Call, and EVDO modes, with both the horizontal and vertical polarizations.

The margins in the Cellular Call and EVDO for harmonic emissions were greater than 25 dB below the accepted limits for all test frequencies.

The margins in the PCS Call and EVDO for harmonic emissions were greater than 25 dB below the accepted limits for all test frequencies.

The following test configurations were measured for model RDV71UW:

The highest ERP in the UMTS band 4, Call Service mode was 27.56 dBm (0.57W) at 1732.6 MHz (channel 1513).

The highest ERP in the UMTS band 4, HSUPA mode was 28.36 dBm (0.69 W) at 1712.4 MHz (channel 1312).

The radiated carrier harmonics were measured up to the 10<sup>th</sup> harmonic for low, middle and high channels in the UMTS band 4 and was measured in Call, and HSUPA modes. Both the horizontal and vertical polarizations were measured.

The margins in the UMTS band 4 for harmonic emissions were greater than 25 dB below the accepted limits for all test frequencies.

### **b) Co-Location Measurements**

The radiated emissions were measured up to 18 GHz for middle channels for simultaneous transmission in the following test configuration combinations:

CDMA CELL/Bluetooth/802.11b, CDMA PCS/Bluetooth/802.11g,  
GSM 850/Bluetooth/802.11g and PCS 1900/Bluetooth/802.11b.

Both the horizontal and vertical polarizations were measured. The emissions due to different simultaneous transmission did not increase the amplitude of any emissions nor did it produce any new inter-modulation products as a result of mixing.

### **Sample Calculation:**

Corrected Signal Level (CSL) is calculated as follows:

CSL (dBm) = Measured Level (dBμV) – Antenna Gain (dBi) + Free Space Loss (dB) – 107 (dB) + Cable Loss (dB) - Preamp (dB) + Filter Loss (dB) – 2.15 (dB)


To view the test data see APPENDIX 4A and 4B.

### **Measurement Uncertainty ±4.6 dB**

**Test Report No.**  
RTS-3933-1105-43B\_Rev1**Dates of Test**  
Feb 7 to March 22, May 6 to May 31 and  
June 19, 2011**FCC ID:** L6ARDU70CW **IC:** 2503A-RDU70CW  
**FCC ID:** L6ARDV70UW **IC:** 2503A-RDV70UW**H) Compliance Test Equipment Used**

<u>UNIT</u>	<u>MANUFACTURER</u>	<u>MODEL</u>	<u>SERIAL NUMBER</u>	<u>CAL DUE DATE</u> (YY MM DD)	<u>USE</u>
Preamplifier	Sonoma	310N/11909A	185831	11-11-24	Radiated Emissions
Preamplifier system	TDK RF Solutions	PA-02	080010	11-11-24	Radiated Emissions
Preamplifier	Rohde & Schwarz	TS-ANA4-SP	001	11-12-01	Radiated Emissions
Preamplifier	Rohde & Schwarz	TS-ANA-SP	001	11-12-01	Radiated Emissions
Hybrid Log Antenna	EMC Automation	HLP-3003C	017401	12-01-04	Radiated Emissions
Horn Antenna	EMC Automation	HRN-0118	030101	12-07-20	Radiated Emissions
Horn Antenna	EMC Automation	HRN-0118	030201	12-09-22	Radiated Emissions
Horn Antenna	Emco	3117	47563	11-07-15	Radiated Emissions
Horn Antenna	CMT	LHA 0180	R52734-001	12-01-21	Radiated Emissions
Dipole Antenna	Schwarzbeck	UHAP	973	12-02-21	Radiated Emissions
Dipole Antenna	Schwarzbeck	UHAP	974	13-02-21	Radiated Emissions
Universal Radio Communication Tester	Rohde & Schwarz	CMU 200	837493/073	11-10-01	Radiated Emissions
Universal Radio Communication Tester	Rohde & Schwarz	CMU 200	112394	11-10-01	Radiated Emissions
Universal Radio Communication Tester	Rohde & Schwarz	CMU 200	102204	11-11-30	RF Conducted Emissions
EMI Receiver	Rohde & Schwarz	ESIB-40	100255	11-11-28	Radiated Emissions
EMI Receiver	Rohde & Schwarz	ESU-40	100162	11-11-30	Radiated Emissions
Spectrum Analyzer	HP	8563E	3745A08112	11-09-30	RF Conducted Emissions
DC Power Supply	HP	6632B	US37472178	11-11-19	RF Conducted Emissions
Environment Monitor	Omega	iTHX-SD	0380561	11-10-13	Radiated Emissions




	EMI Test Report for the BlackBerry® smartphone Model RDU71CW,RDV71UW	
<b>Test Report No.</b> RTS-3933-1105-43B_Rev1	<b>Dates of Test</b> Feb 7 to March 22, May 6 to May 31 and June 19, 2011	<b>FCC ID:</b> L6ARDU70CW <b>IC:</b> 2503A-RDU70CW <b>FCC ID:</b> L6ARDV70UW <b>IC:</b> 2503A-RDV70UW

### Compliance Test Equipment Used cont'd

<u>UNIT</u>	<u>MANUFACTURER</u>	<u>MODEL</u>	<u>SERIAL NUMBER</u>	<u>CAL DUE DATE</u> (YY MM DD)	<u>USE</u>
Environment Monitor	Omega	iTHX-SD	0340060	11-10-13	RF Conducted Emissions
Environment Monitor	Omega	iTHX-SD	0380567	11-10-13	Radiated Emissions
Signal Generator	Agilent	E8257D	MY45140527	11-11-05	Radiated Emissions
Signal Generator	Agilent	83630B	3844A00927	12-10-28	Radiated Emissions

## APPENDIX 1A – GSM CONDUCTED RF EMISSIONS TEST DATA/PLOTS

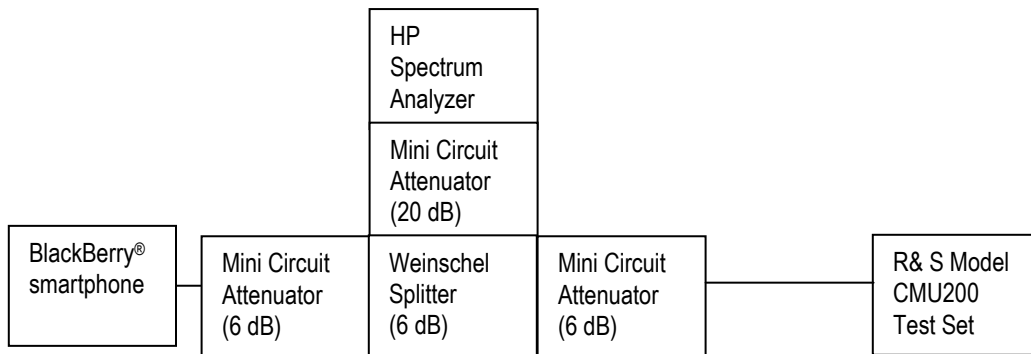
	EMI Test Report for the BlackBerry® smartphone Model RDU71CW, RDV71UW APPENDIX 1A	
<b>Test Report No.</b> RTS-3933-1105-43B_Rev1	<b>Dates of Test</b> Feb 7 to March 22, May 6 to May 31 and June 19, 2011	<b>FCC ID:</b> L6ARDU70CW <b>IC:</b> 2503A-RDU70CW <b>FCC ID:</b> L6ARDV70UW <b>IC:</b> 2503A-RDV70UW

### GSM Conducted RF Emission Test Data

The following test configurations were measured for model RDU71CW:

This appendix contains measurement data pertaining to conducted spurious emissions, -26 dBc bandwidth, 99% power bandwidth and the channel mask on BlackBerry® smartphone.

### **Test Setup Diagram**




Date of Test: March 04, 2011

The environmental test conditions were:

Temperature: 23.7 °C

Relative Humidity: 37.8 %

The following measurements were performed by Maurice Battler.

	EMI Test Report for the BlackBerry® smartphone Model RDU71CW, RDV71UW APPENDIX 1A	
	<b>Test Report No.</b> RTS-3933-1105-43B_Rev1	<b>Dates of Test</b> Feb 7 to March 22, May 6 to May 31 and June 19, 2011

GSM Conducted RF Emission Test Data cont'd

**The conducted spurious emissions** – As per 47 CFR 2.1051, CFR 24.238(a), RSS-GEN, 4.9, CFR 22 Subpart H and RSS-132 were measured from 10 MHz to 20 GHz. The EUT emissions were in the noise floor.  
 See figures 1-1a to 1-12a for the plots of the conducted spurious emissions.

**–26 dBc Bandwidth and Occupied Bandwidth (99%)**

For each carrier frequency of low, middle and high, the modulation spectrum was measured by both methods of 99% power bandwidth and –26 dBc bandwidth.

The resolution bandwidth required for out-of-band emissions in the 1 MHz bands immediately outside and adjacent to the frequency block, was determined to be at least 1% of the emission bandwidth.

The worst case –26dBc bandwidth for the GSM850 band was measured to be 270 kHz, and for the PCS1900 band was measured to be 278 kHz as shown below. This results in a 3.0 kHz resolution bandwidth.

On any frequency outside the frequency block and outside the adjacent 1 MHz bands, a resolution bandwidth of at least 1 MHz was applied.

*Test Data for 850 band and 1900 band selected Frequencies in GSM mode.*

850 band Frequency (MHz)	-26dBc Bandwidth (kHz)	99% Occupied Bandwidth (kHz)
824.2	270	245
837.6	263	245
848.8	270	246.7


1900 band Frequency (MHz)	-26dBc Bandwidth (kHz)	99% Occupied Bandwidth (kHz)
1850.2	277	245
1880.0	275	243.3
1909.8	278	243.3

***Measurement Plots for 850 and 1900 in GSM mode***

Refer to the following measurement plots for more detail.

See Figures 1-13a to 1-24a for the plots of 26dBc/99% Occupied Bandwidth.

The RF power output was at maximum for all the recorded measurements shown below.

	EMI Test Report for the BlackBerry® smartphone Model RDU71CW, RDV71UW APPENDIX 1A	
<b>Test Report No.</b> RTS-3933-1105-43B_Rev1	<b>Dates of Test</b> Feb 7 to March 22, May 6 to May 31 and June 19, 2011	<b>FCC ID:</b> L6ARDU70CW <b>IC:</b> 2503A-RDU70CW <b>FCC ID:</b> L6ARDV70UW <b>IC:</b> 2503A-RDV70UW

GSM Conducted RF Emission Test Data cont'd

Date of Test: March 04, 2011

*Test Data for 850 and 1900 bands selected Frequencies in EDGE mode.*

850 band Frequency (MHz)	99% Occupied Bandwidth (kHz)
824.2	245.0
837.6	243.3
848.8	246.7

1900 band Frequency (MHz)	99% Occupied Bandwidth (kHz)
1850.2	243.3
1880.0	245.0
1909.8	245.0

***Measurement Plots for 850 and 1900 bands in EDGE mode***

Refer to the following measurement plots for more detail.

See Figures 1-1a to 1-12a for the plots of the conducted spurious emissions.

See Figures 1-13a to 1-24a for the plots of 26dBc/99% Occupied Bandwidth.

See Figures 1-25a to 1-28a for the plots of the Channel mask.

See Figures 1-29a to 1-34a for the plots of the 99% Occupied Bandwidth EDGE results.

See Figures 1-35a to 1-38a for the plots of channel mask EDGE results.

See Figures 1-39a to 1-50a for the plots of the conducted spurious emissions EDGE results

The RF power output was at maximum for all the recorded measurements shown below.

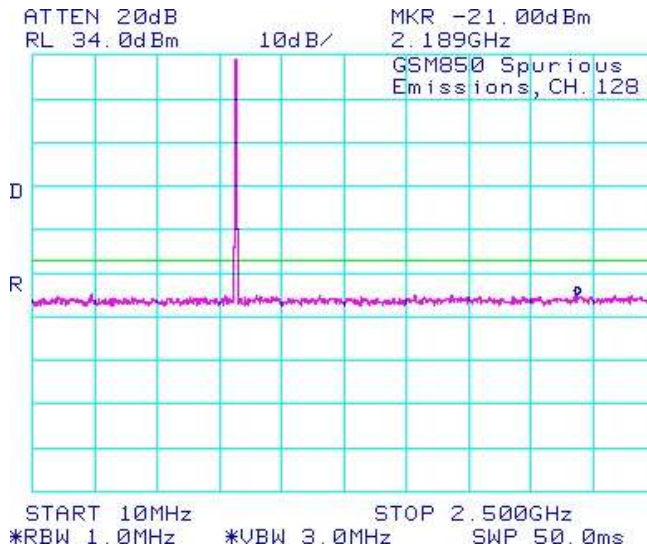
**Test Report No.**  
RTS-3933-1105-43B\_Rev1

**Dates of Test**  
Feb 7 to March 22, May 6 to May 31 and  
June 19, 2011

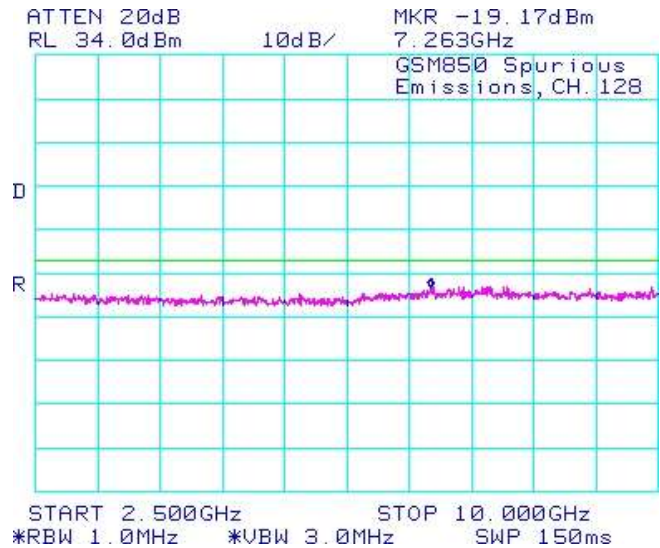
**FCC ID:** L6ARDU70CW **IC:** 2503A-RDU70CW  
**FCC ID:** L6ARDV70UW **IC:** 2503A-RDV70UW

GSM Conducted RF Emission Test Data cont'd

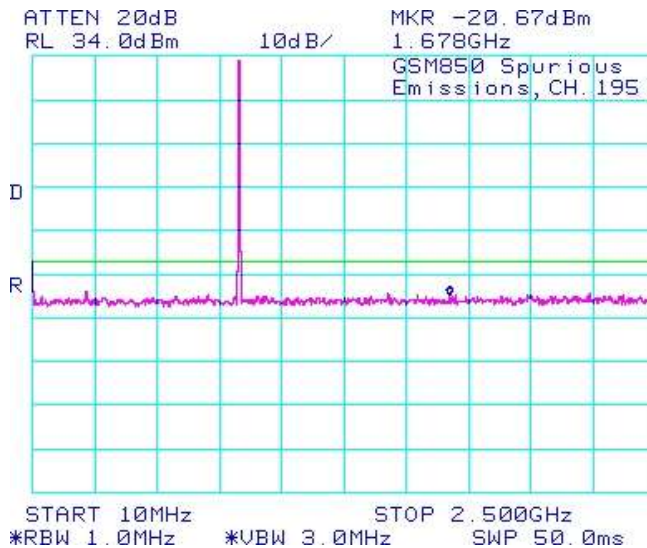
**Figure 1-1a: GSM850 band, Spurious Conducted Emissions, Low channel**



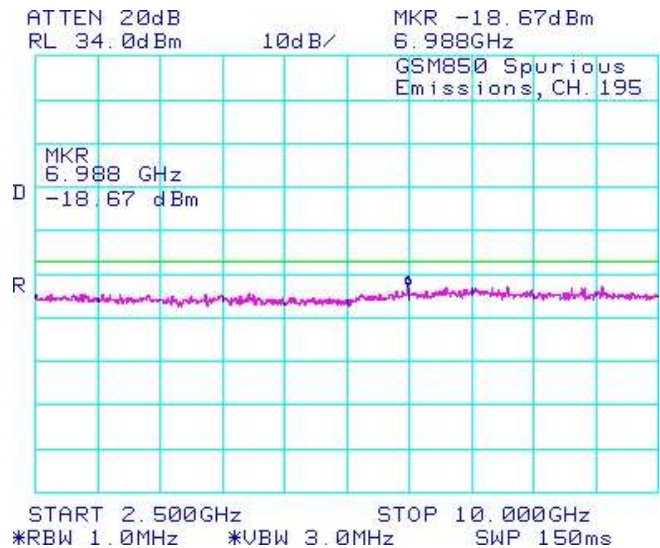
**Figure 1-2a: GSM850 band, Spurious Conducted Emissions, Low channel**



**Figure 1-3a: GSM850 band, Spurious Conducted Emissions, Middle Channel**



**Figure 1-4a: GSM850 band, Spurious Conducted Emissions, Middle Channel**



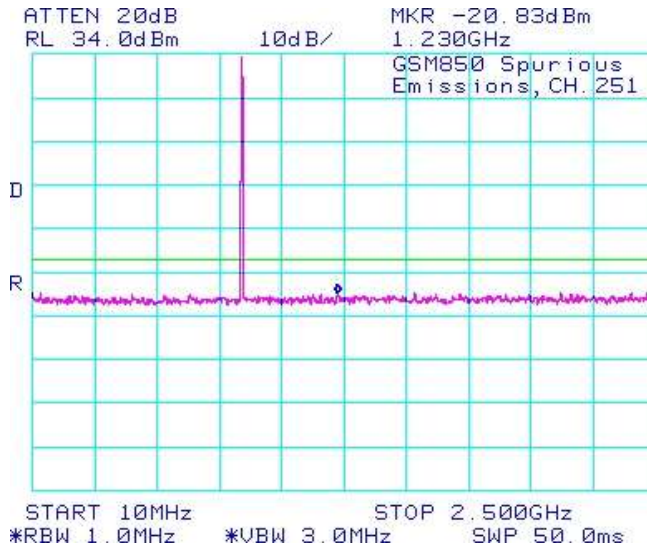
**Test Report No.**  
RTS-3933-1105-43B\_Rev1

**Dates of Test**  
Feb 7 to March 22, May 6 to May 31 and  
June 19, 2011

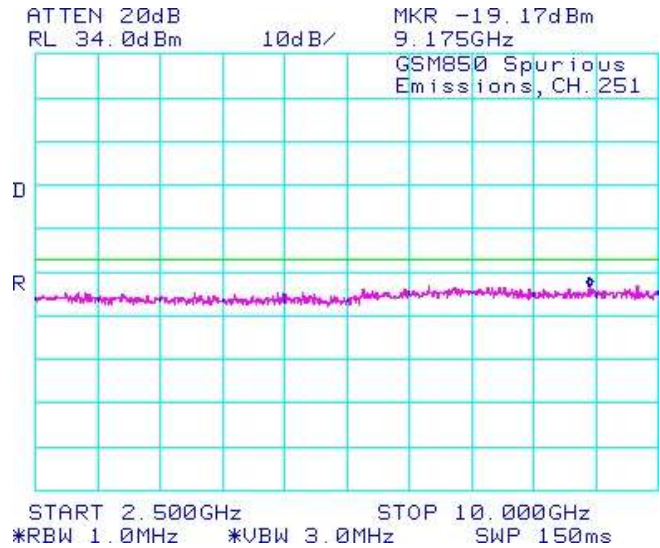
**FCC ID:** L6ARDU70CW **IC:** 2503A-RDU70CW  
**FCC ID:** L6ARDV70UW **IC:** 2503A-RDV70UW

GSM Conducted RF Emission Test Data cont'd

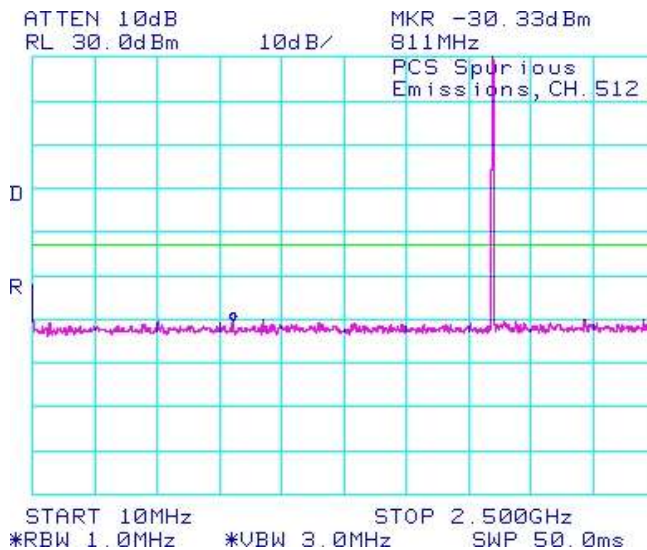
**Figure 1-5a: GSM850 band, Spurious Conducted Emissions, High Channel**



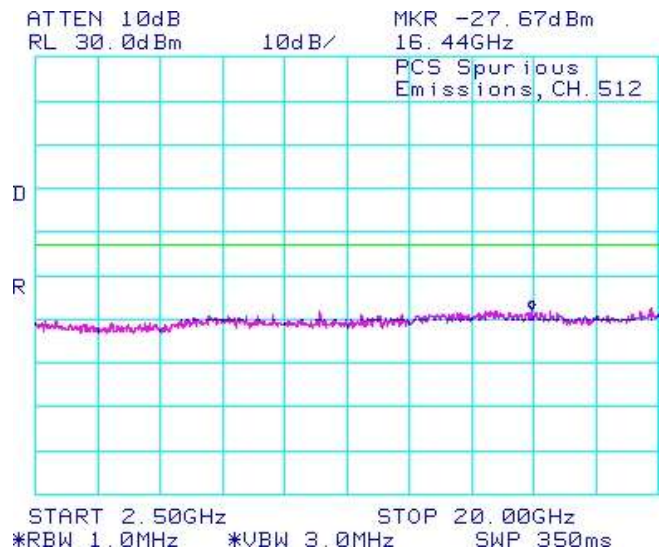
**Figure 1-6a: GSM850 band, Spurious Conducted Emissions, High Channel**




**Figure 1-7a: PCS1900 band, Spurious Conducted Emissions, Low Channel**



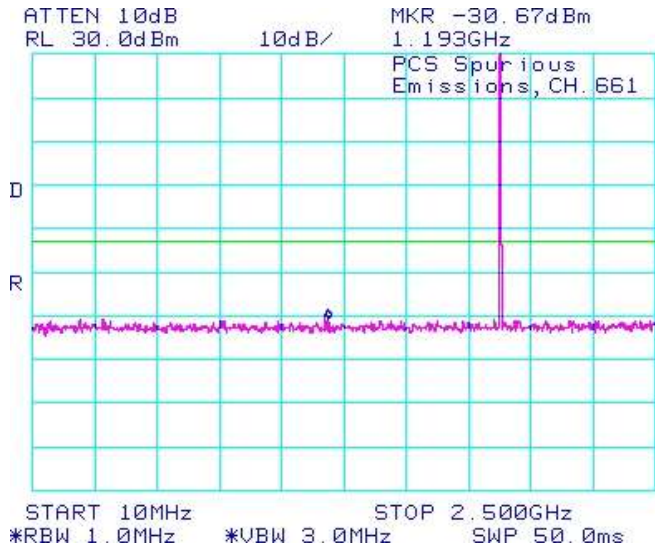
**Figure 1-8a: PCS1900 band, Spurious Conducted Emissions, Low Channel**



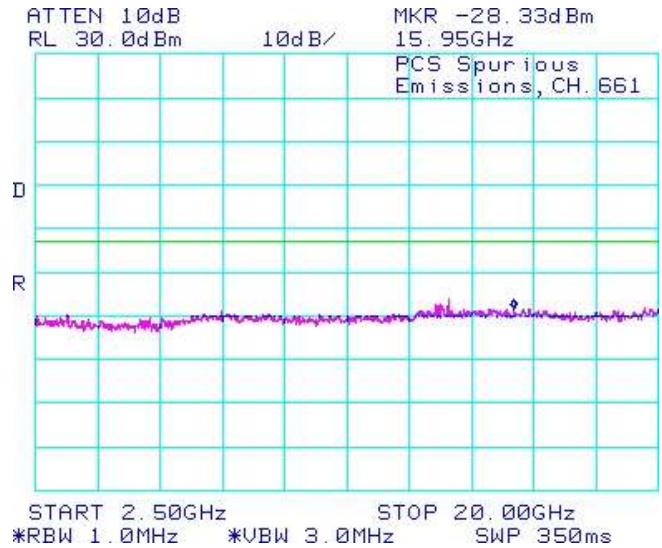
	EMI Test Report for the BlackBerry® smartphone Model RDU71CW, RDV71UW APPENDIX 1A	
<b>Test Report No.</b> RTS-3933-1105-43B_Rev1	<b>Dates of Test</b> Feb 7 to March 22, May 6 to May 31 and June 19, 2011	<b>FCC ID:</b> L6ARDU70CW <b>IC:</b> 2503A-RDU70CW <b>FCC ID:</b> L6ARDV70UW <b>IC:</b> 2503A-RDV70UW

GSM Conducted RF Emission Test Data cont'd

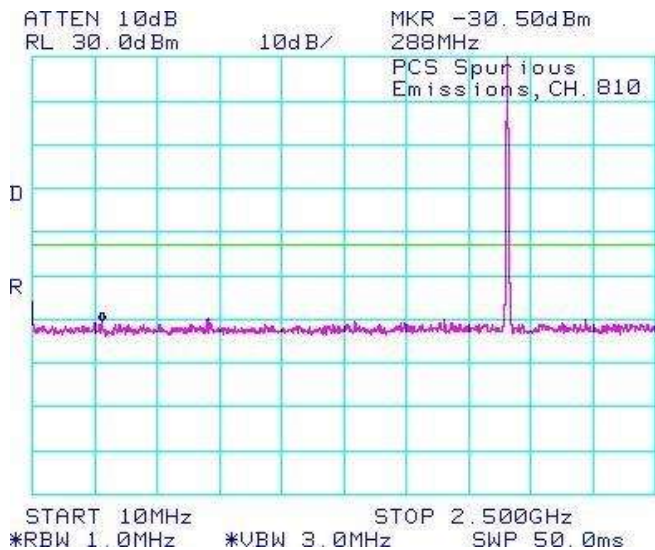
**Figure 1-9a: PCS1900 band, Spurious Conducted Emissions, Middle Channel**



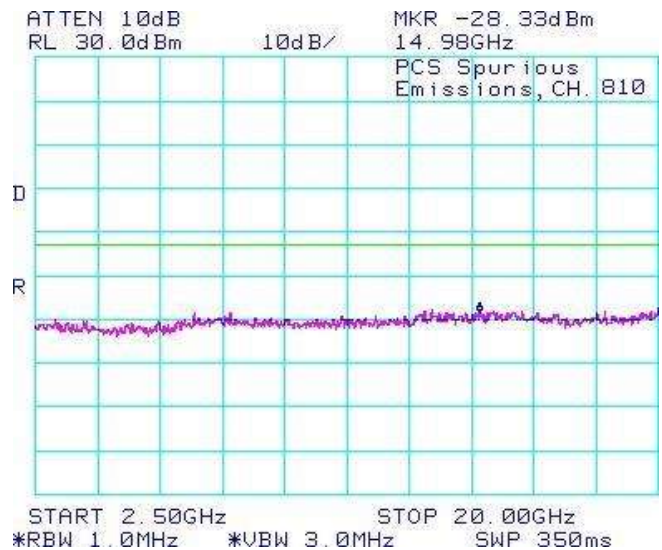
**Figure 1-10a: PCS1900 band, Spurious Conducted Emissions, Middle Channel**



**Figure 1-11a: PCS1900 band, Spurious Conducted Emissions, High Channel**



**Figure 1-12a: PCS1900 band, Spurious Conducted Emissions, High Channel**





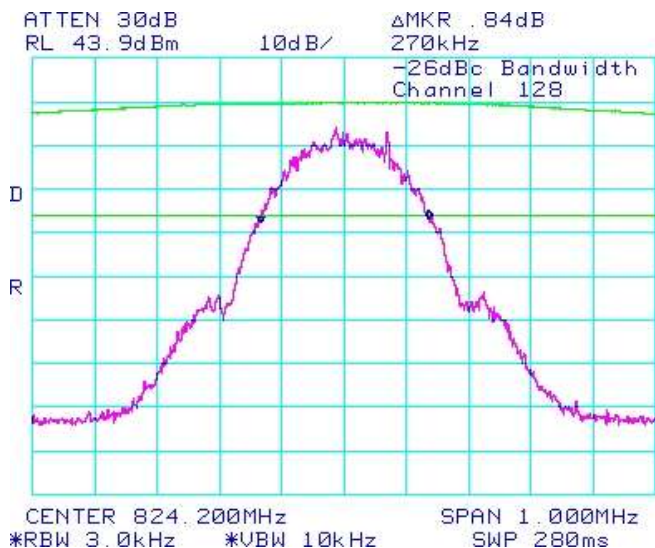
**Test Report No.**  
RTS-3933-1105-43B\_Rev1

**Dates of Test**  
Feb 7 to March 22, May 6 to May 31 and  
June 19, 2011

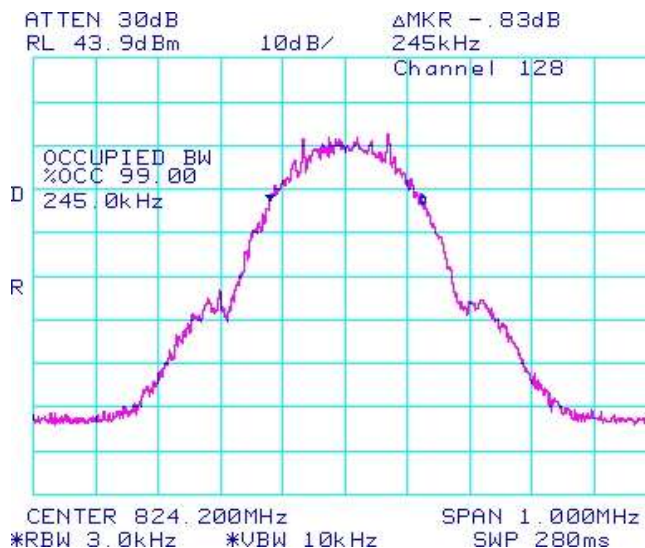
**FCC ID:** L6ARDU70CW **IC:** 2503A-RDU70CW  
**FCC ID:** L6ARDV70UW **IC:** 2503A-RDV70UW

GSM Conducted RF Emission Test Data cont'd

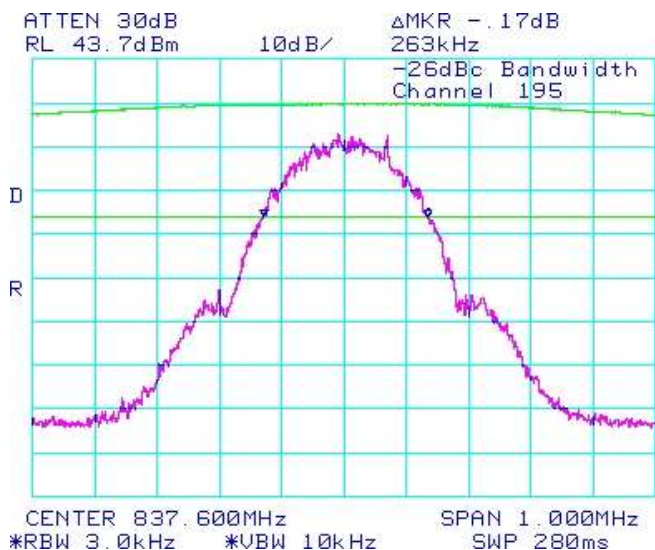
**Figure 1-13a: -26dBc bandwidth, GSM850 band  
Low Channel in GSM mode**



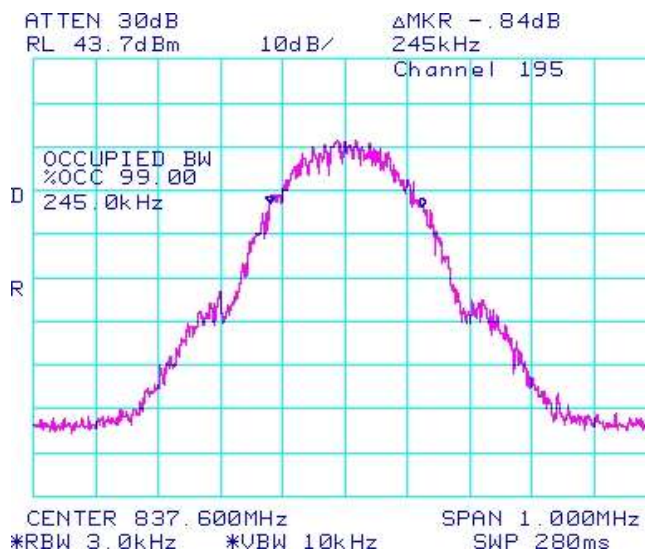
**Figure 1-14a: Occupied Bandwidth, GSM850 band  
Low Channel in GSM mode**



**Figure 1-15a: -26dBc bandwidth, GSM850 band  
Middle Channel in GSM mode**



**Figure 1-16a: Occupied Bandwidth, GSM850 band  
Middle Channel in GSM mode**



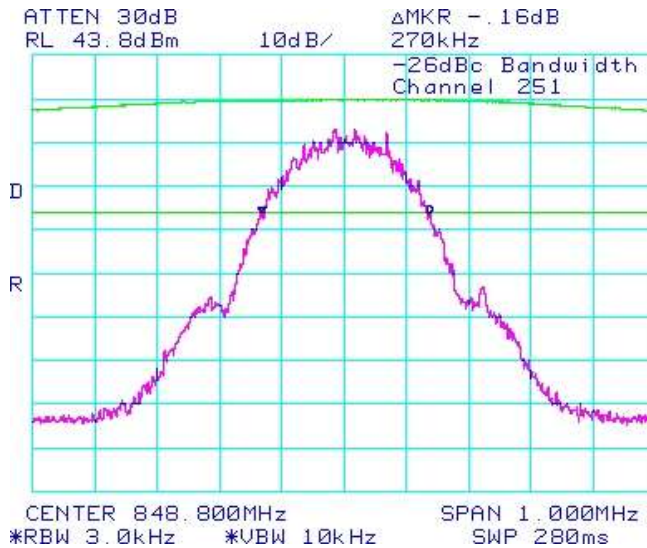
**Test Report No.**  
RTS-3933-1105-43B\_Rev1

**Dates of Test**  
Feb 7 to March 22, May 6 to May 31 and  
June 19, 2011

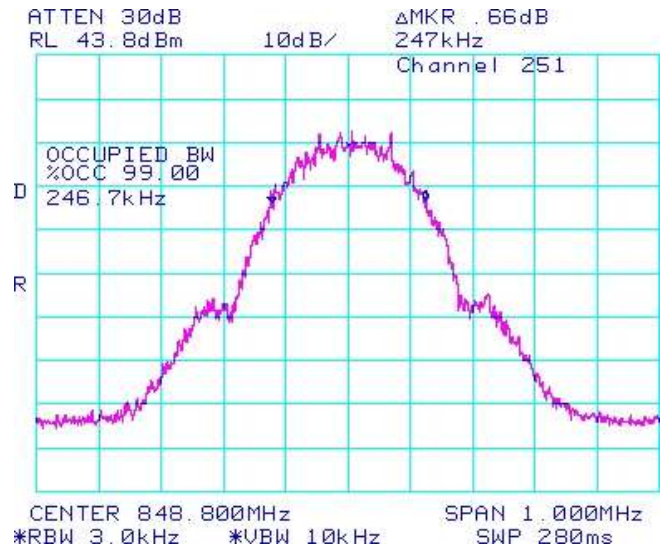
**FCC ID:** L6ARDU70CW **IC:** 2503A-RDU70CW  
**FCC ID:** L6ARDV70UW **IC:** 2503A-RDV70UW

GSM Conducted RF Emission Test Data cont'd

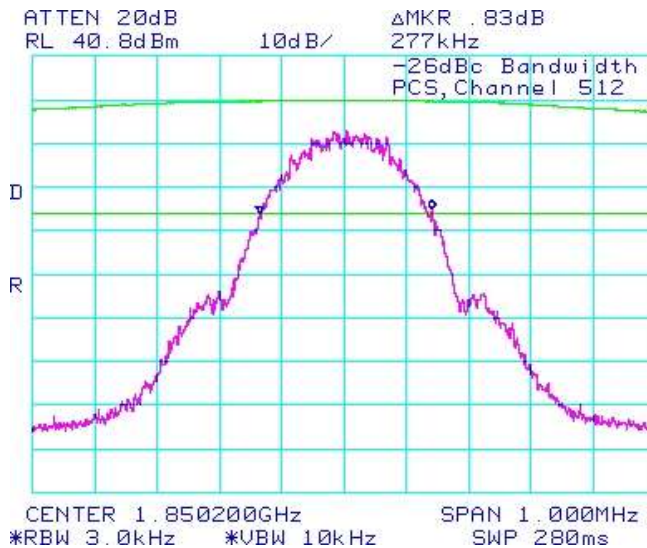
**Figure 1-17a: -26dBc bandwidth, GSM850 band High Channel in GSM mode**



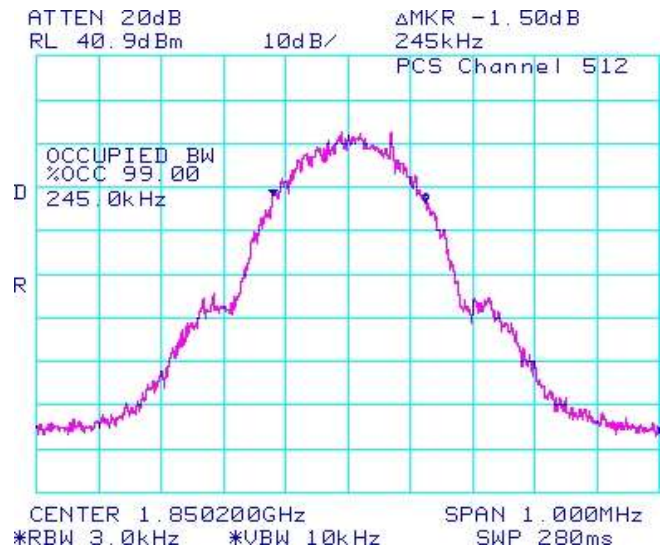
**Figure 1-18a: Occupied Bandwidth, GSM850 band High Channel in GSM mode**



**Figure 1-19a: -26dBc bandwidth, PCS1900 Low Channel in GSM mode**



**Figure 1-20a: Occupied Bandwidth, PCS1900 Low Channel in GSM mode**



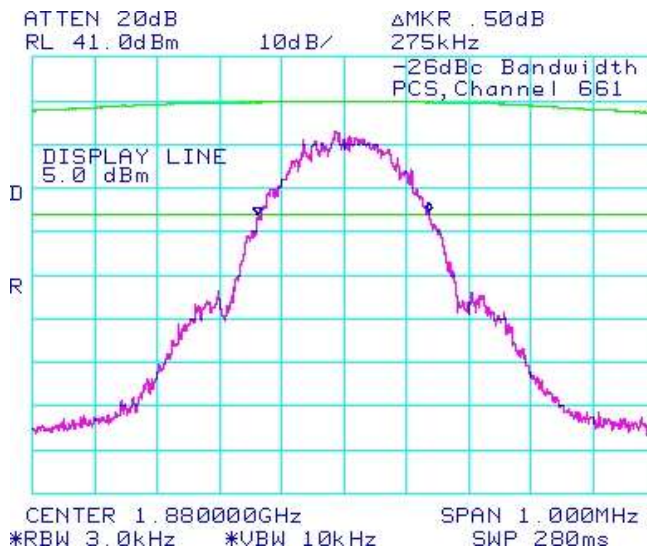
**Test Report No.**  
RTS-3933-1105-43B\_Rev1

**Dates of Test**  
Feb 7 to March 22, May 6 to May 31 and  
June 19, 2011

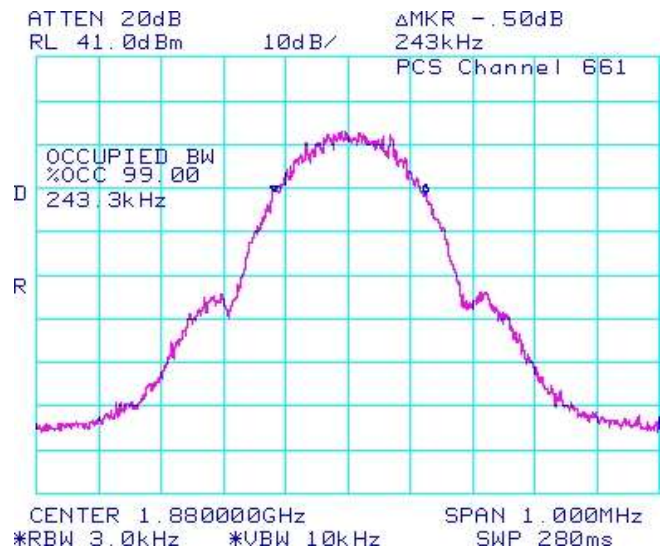
**FCC ID:** L6ARDU70CW **IC:** 2503A-RDU70CW  
**FCC ID:** L6ARDV70UW **IC:** 2503A-RDV70UW

GSM Conducted RF Emission Test Data cont'd

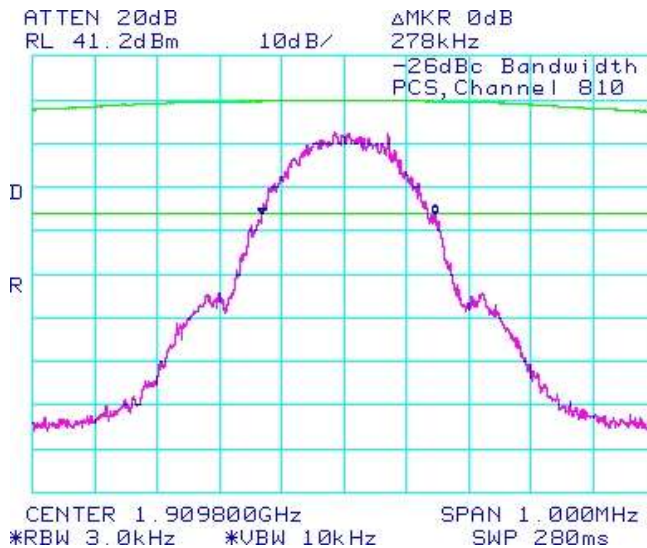
**Figure 1-21a: -26dBc bandwidth, PCS1900 Middle Channel in GSM mode**



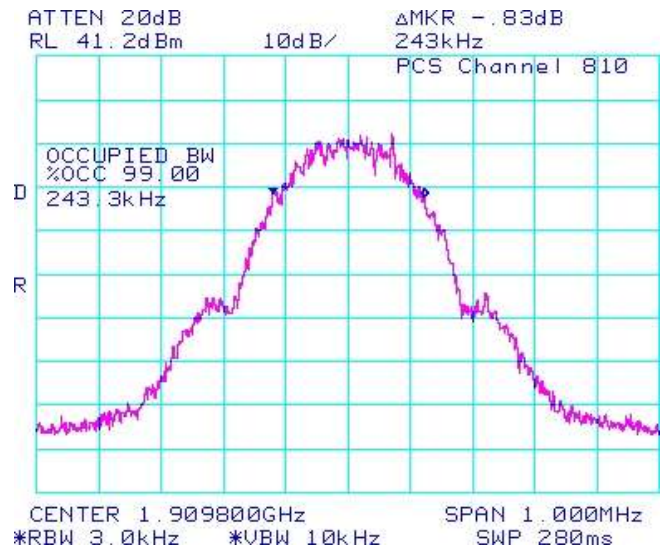
**Figure 1-22a: Occupied Bandwidth, PCS1900 Middle Channel in GSM mode**




**Figure 1-23a: -26dBc bandwidth, PCS1900 High Channel in GSM mode**



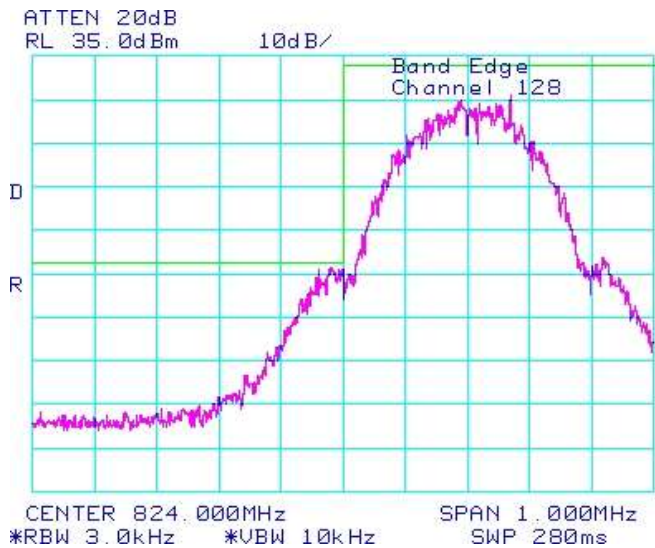
**Figure 1-24a: Occupied Bandwidth, PCS1900 High Channel in GSM mode**



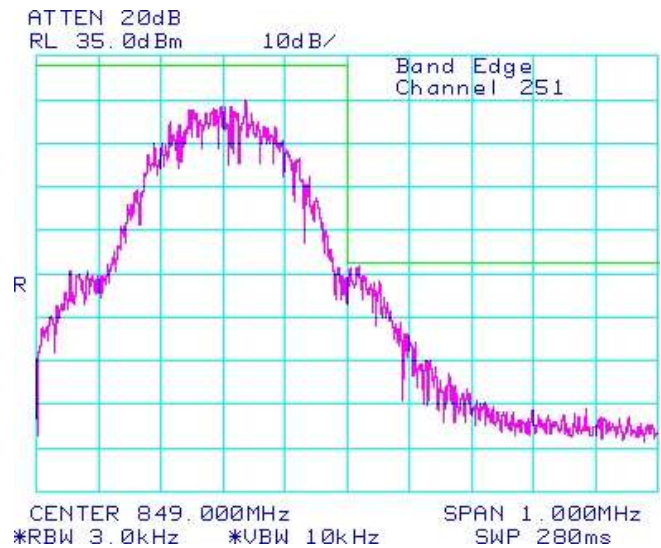
	EMI Test Report for the BlackBerry® smartphone Model RDU71CW, RDV71UW APPENDIX 1A	
<b>Test Report No.</b> RTS-3933-1105-43B_Rev1	<b>Dates of Test</b> Feb 7 to March 22, May 6 to May 31 and June 19, 2011	<b>FCC ID:</b> L6ARDU70CW <b>IC:</b> 2503A-RDU70CW <b>FCC ID:</b> L6ARDV70UW <b>IC:</b> 2503A-RDV70UW

GSM Conducted RF Emission Test Data cont'd

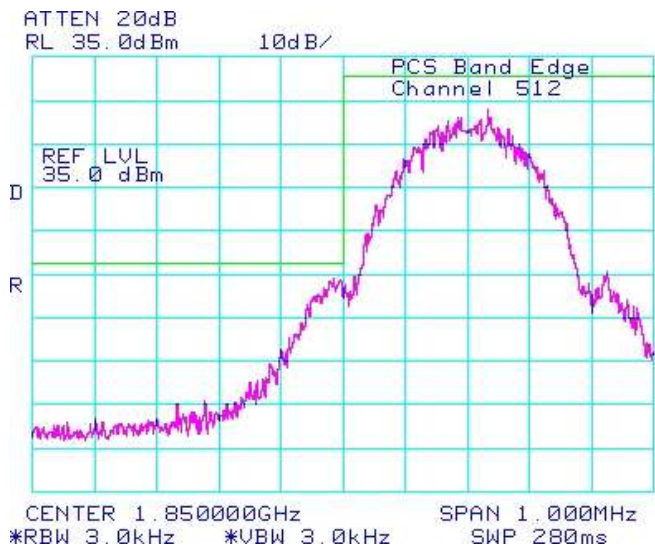
**Figure 1-25a: GSM850 band, Low Channel Mask in GSM mode**



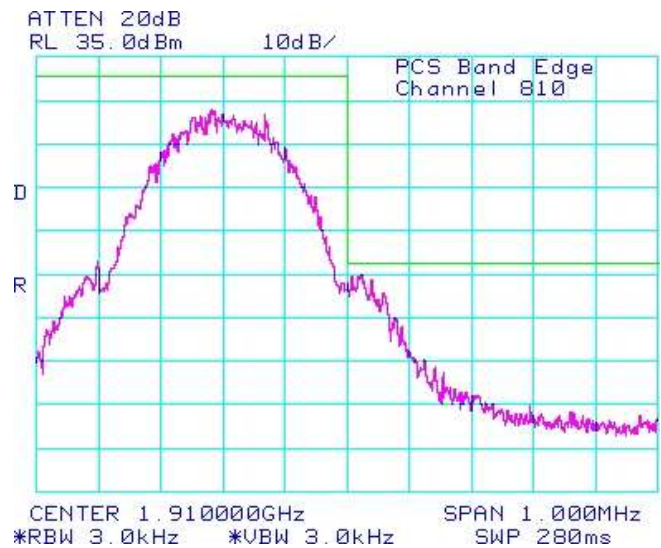
**Figure 1-26a: GSM850 band High Channel Mask in GSM mode**



**Figure 1-27a: PCS1900, Low Channel Mask in GSM mode**



**Figure 1-28a: PCS1900, High Channel Mask in GSM mode**



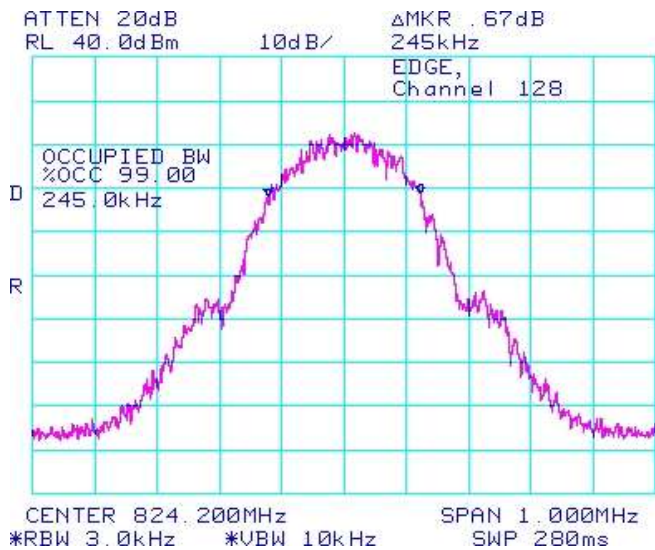
**Test Report No.**  
RTS-3933-1105-43B\_Rev1

**Dates of Test**  
Feb 7 to March 22, May 6 to May 31 and  
June 19, 2011

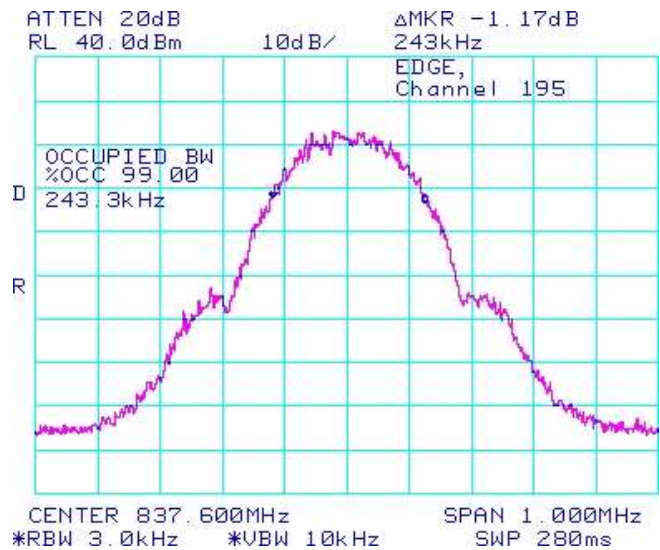
**FCC ID:** L6ARDU70CW **IC:** 2503A-RDU70CW  
**FCC ID:** L6ARDV70UW **IC:** 2503A-RDV70UW

GSM Conducted RF Emission Test Data cont'd

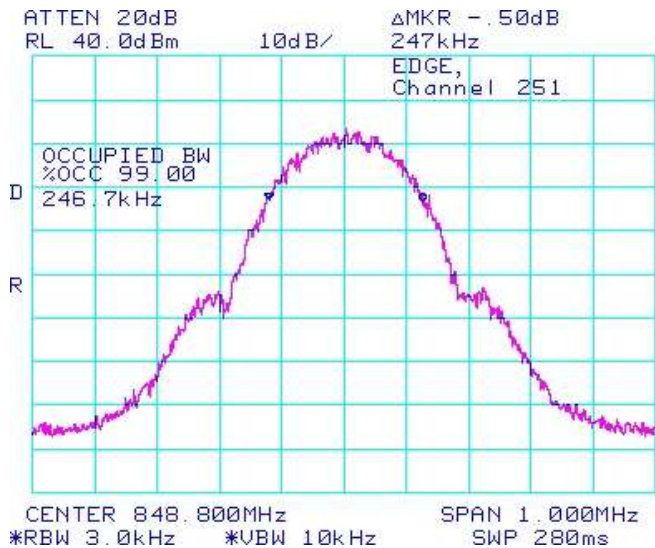
**Figure 1-29a: Occupied Bandwidth, GSM850 Band, Low Channel in EDGE mode**



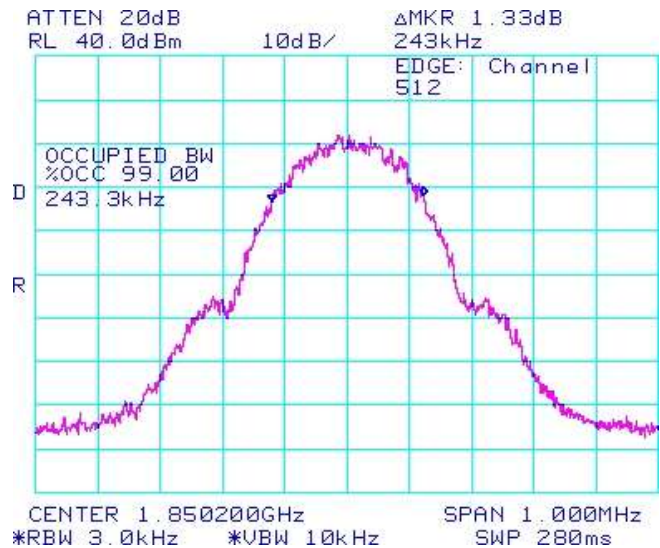
**Figure 1-30a: Occupied Bandwidth, GSM850 Band, Middle Channel in EDGE mode**




**Figure 1-31a: Occupied Bandwidth, GSM850 band, High Channel in EDGE mode**



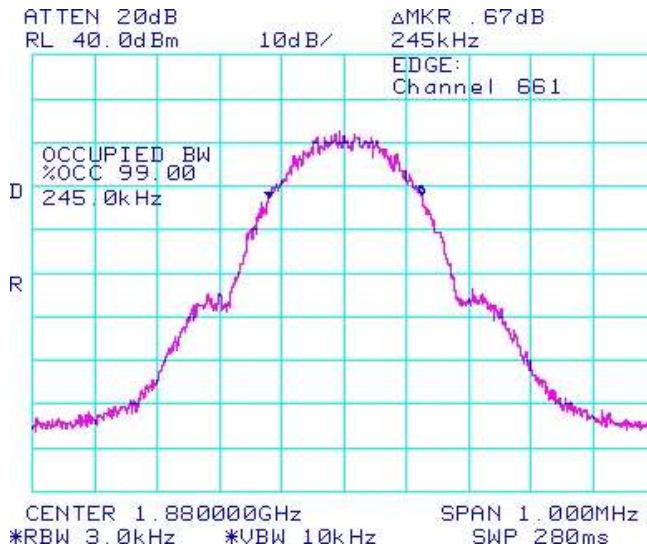
**Figure 1-32a: Occupied Bandwidth, PCS1900 Band, Low Channel in EDGE mode**



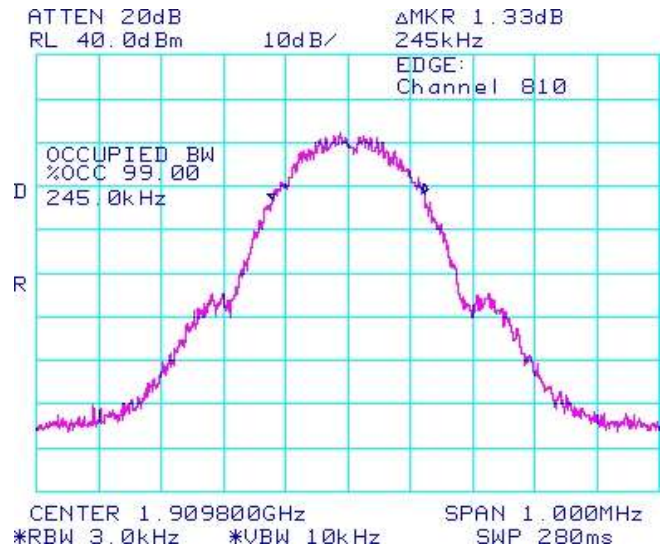
	EMI Test Report for the BlackBerry® smartphone Model RDU71CW, RDV71UW APPENDIX 1A	
<b>Test Report No.</b> RTS-3933-1105-43B_Rev1	<b>Dates of Test</b> Feb 7 to March 22, May 6 to May 31 and June 19, 2011	<b>FCC ID:</b> L6ARDU70CW <b>IC:</b> 2503A-RDU70CW <b>FCC ID:</b> L6ARDV70UW <b>IC:</b> 2503A-RDV70UW

GSM Conducted RF Emission Test Data cont'd

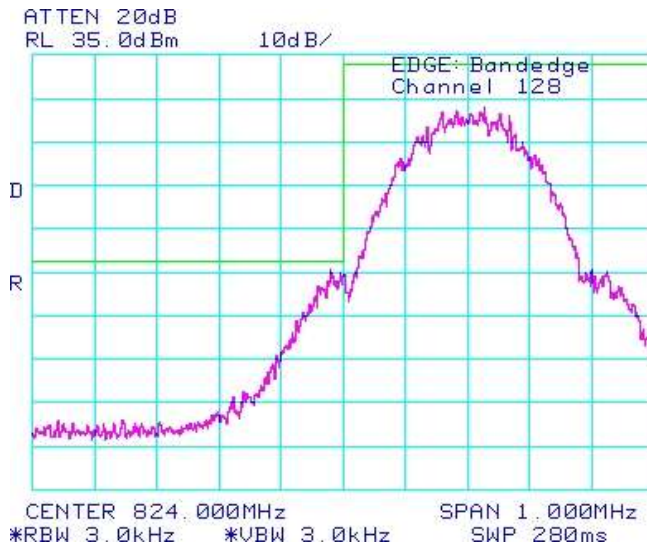
**Figure 1-33a: Occupied Bandwidth, PCS1900 Band, Middle Channel in EDGE mode**



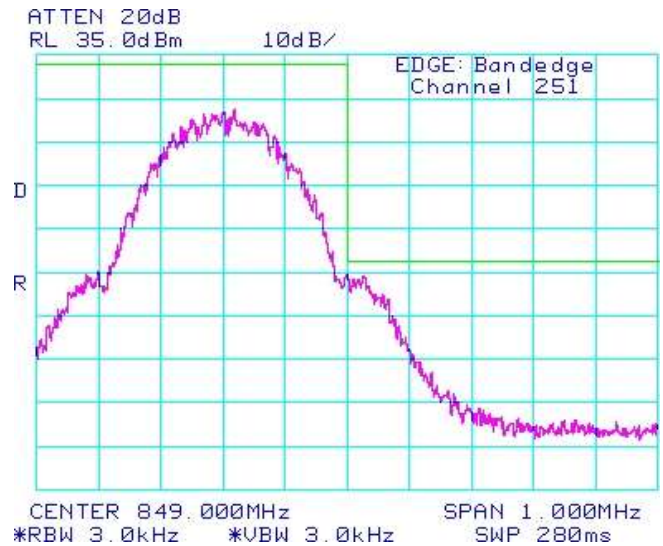
**Figure 1-34a: Occupied Bandwidth, PCS1900 Band, High Channel in EDGE mode**




**Figure 1-35a: GSM850 Band, Low Channel Mask in EDGE mode**



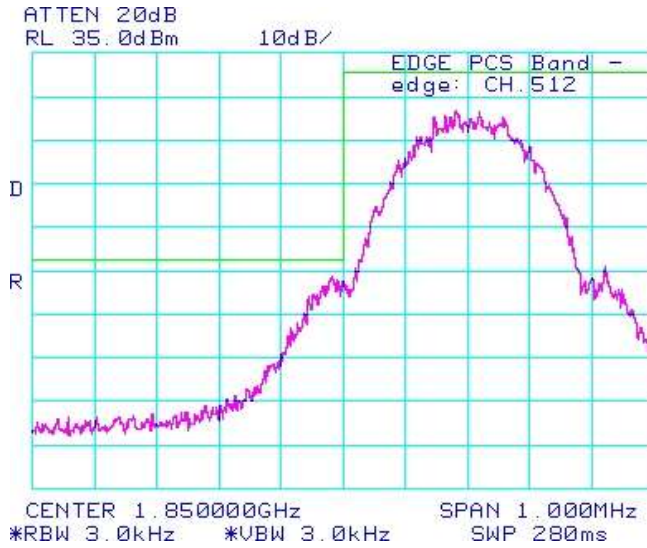
**Figure 1-36a: GSM850 Band, High Channel Mask in EDGE mode**



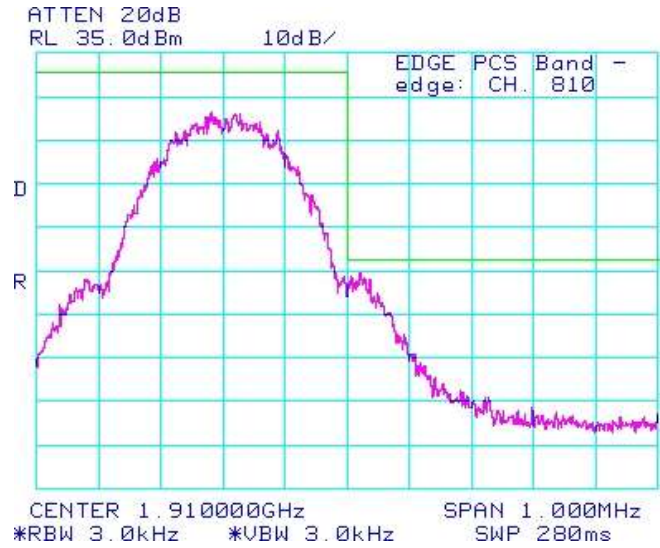
	EMI Test Report for the BlackBerry® smartphone Model RDU71CW, RDV71UW APPENDIX 1A	
<b>Test Report No.</b> RTS-3933-1105-43B_Rev1	<b>Dates of Test</b> Feb 7 to March 22, May 6 to May 31 and June 19, 2011	<b>FCC ID:</b> L6ARDU70CW <b>IC:</b> 2503A-RDU70CW <b>FCC ID:</b> L6ARDV70UW <b>IC:</b> 2503A-RDV70UW

GSM Conducted RF Emission Test Data cont'd

**Figure 1-37a: PCS1900 Band, Low Channel Mask in EDGE mode**



**Figure 1-38a: PCS1900 Band, High Channel Mask in EDGE mode**



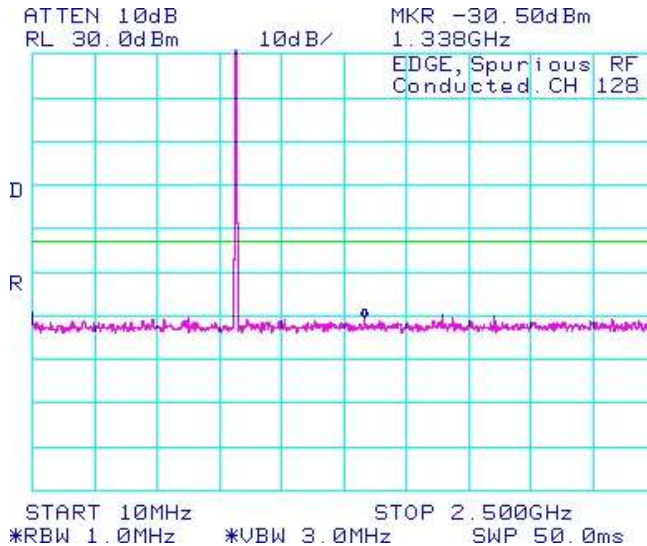
**Test Report No.**  
RTS-3933-1105-43B\_Rev1

**Dates of Test**  
Feb 7 to March 22, May 6 to May 31 and  
June 19, 2011

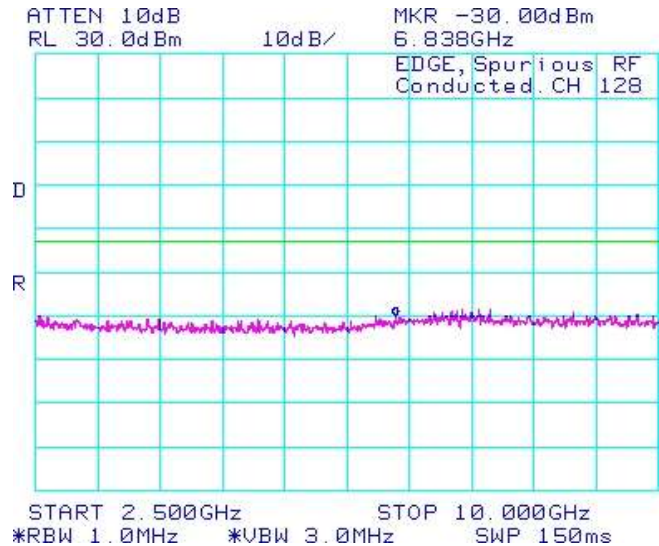
**FCC ID:** L6ARDU70CW **IC:** 2503A-RDU70CW  
**FCC ID:** L6ARDV70UW **IC:** 2503A-RDV70UW

GSM Conducted RF Emission Test Data cont'd

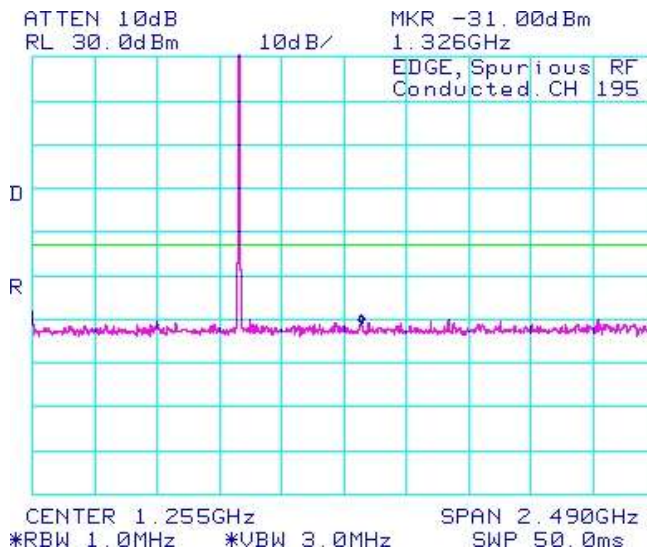
**Figure 1-39a: GSM850 band, Spurious Conducted Emissions, Low channel in Edge Mode**



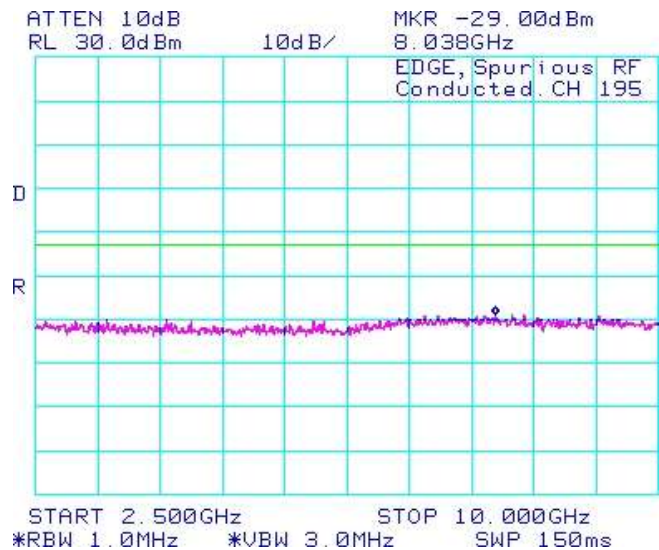
**Figure 1-40a: GSM850 band, Spurious Conducted Emissions, Low channel in Edge Mode**



**Figure 1-41a: GSM850 band, Spurious Conducted Emissions, Middle channel in Edge Mode**



**Figure 1-42a: GSM850 band, Spurious Conducted Emissions, Middle channel in Edge Mode**





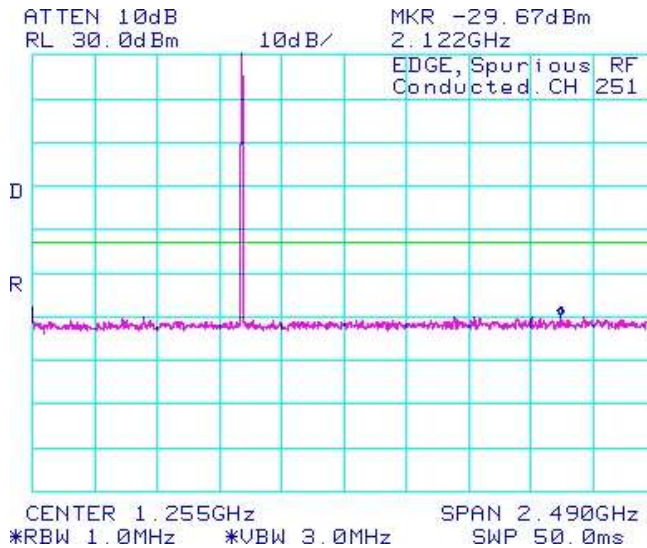
**Test Report No.**  
RTS-3933-1105-43B\_Rev1

**Dates of Test**  
Feb 7 to March 22, May 6 to May 31 and  
June 19, 2011

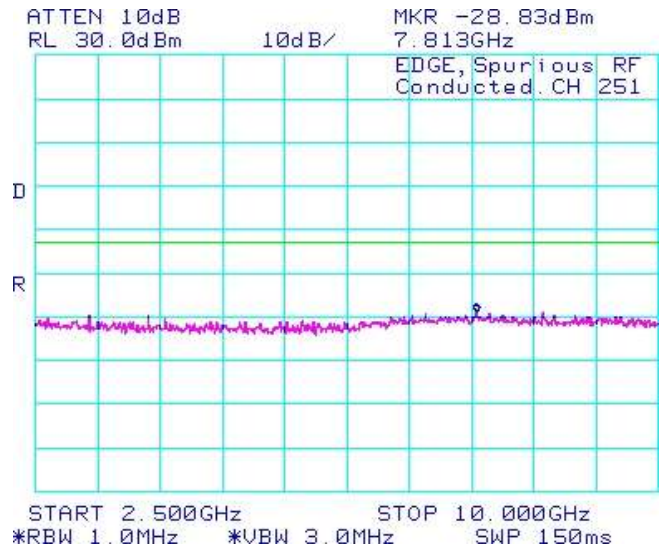
**FCC ID:** L6ARDU70CW **IC:** 2503A-RDU70CW  
**FCC ID:** L6ARDV70UW **IC:** 2503A-RDV70UW

GSM Conducted RF Emission Test Data cont'd

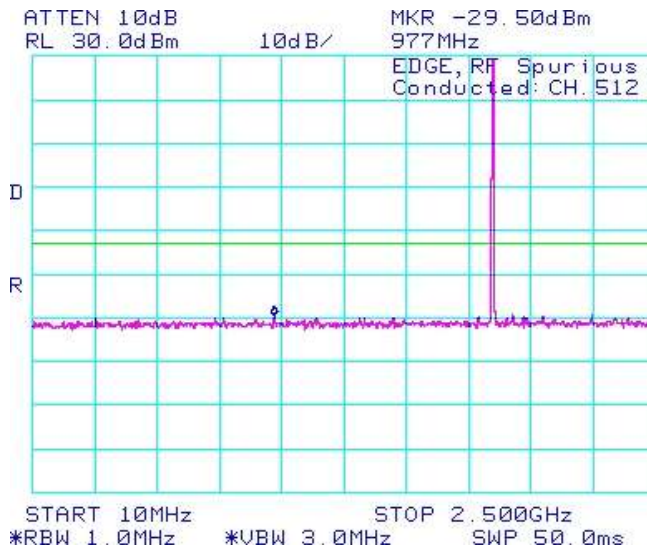
**Figure 1-43a: GSM850 band, Spurious Conducted Emissions, High channel in Edge Mode**



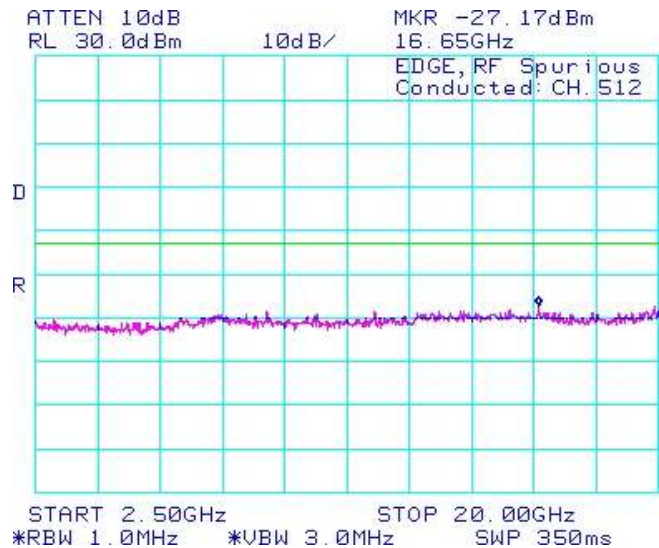
**Figure 1-44a: GSM850 band, Spurious Conducted Emissions, High channel in Edge Mode**



**Figure 1-45a: PCS1900 band, Spurious Conducted Emissions, Low channel in Edge Mode**



**Figure 1-46a: PCS1900 band, Spurious Conducted Emissions, Low channel in Edge Mode**



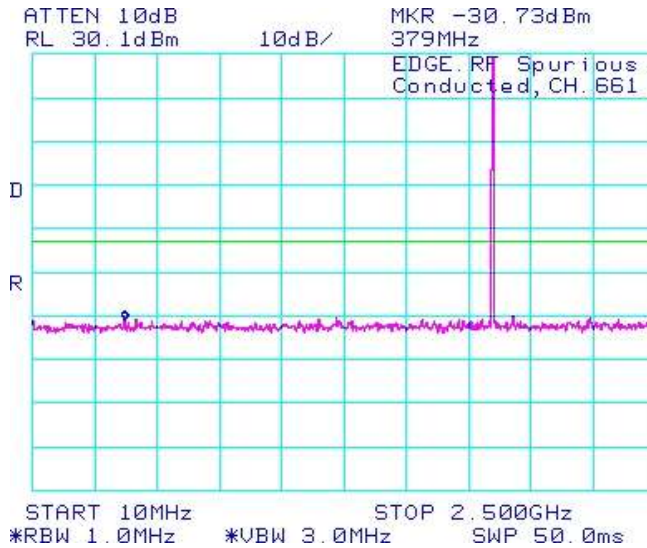
**Test Report No.**  
RTS-3933-1105-43B\_Rev1

**Dates of Test**  
Feb 7 to March 22, May 6 to May 31 and  
June 19, 2011

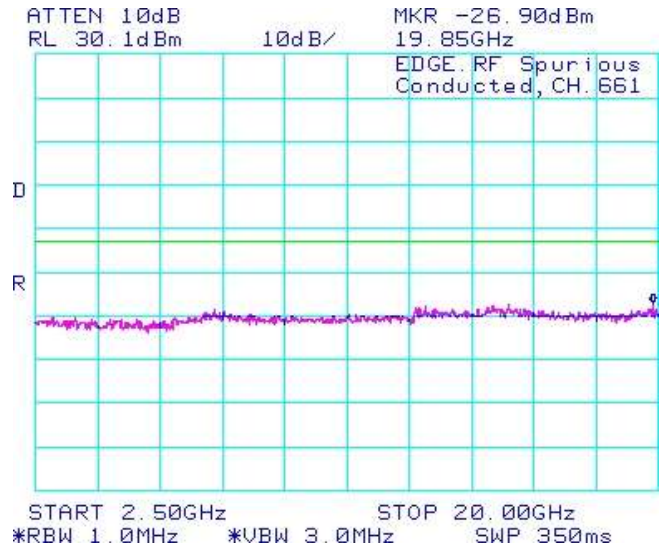
**FCC ID:** L6ARDU70CW **IC:** 2503A-RDU70CW  
**FCC ID:** L6ARDV70UW **IC:** 2503A-RDV70UW

GSM Conducted RF Emission Test Data cont'd

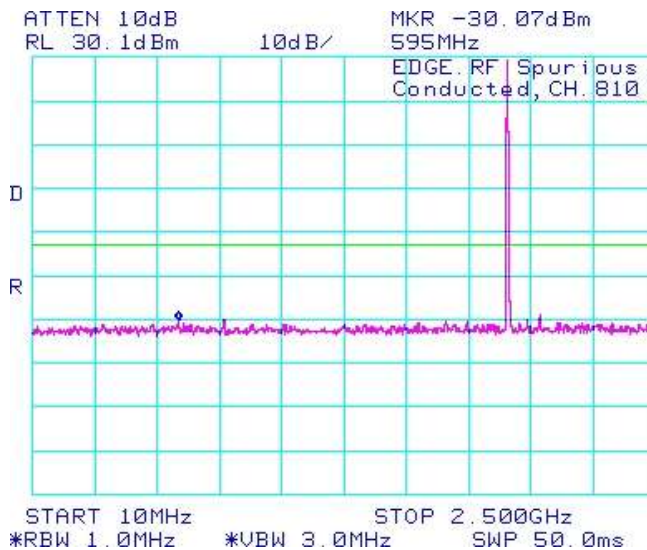
**Figure 1-47a: PCS1900 band, Spurious Conducted Emissions, Low channel in Edge Mode**



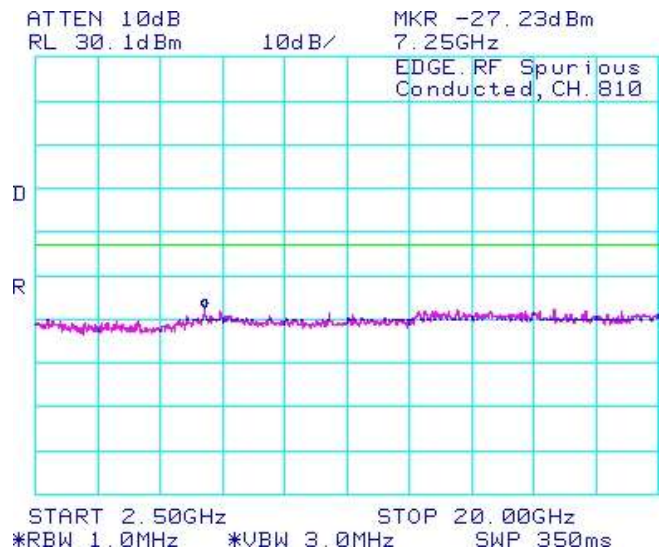
**Figure 1-48a: PCS1900 band, Spurious Conducted Emissions, Low channel in Edge Mode**



**Figure 1-49a: PCS1900 band, Spurious Conducted Emissions, High channel in Edge Mode**




**Figure 1-50a: PCS1900 band, Spurious Conducted Emissions, High channel in Edge Mode**



## APPENDIX 1B – CDMA CONDUCTED RF EMISSIONS TEST DATA/PLOTS



	EMI Test Report for the BlackBerry® smartphone Model RDU71CW, RDV71UW APPENDIX 1B	
<b>Test Report No.</b> RTS-3933-1105-43B_Rev1	<b>Dates of Test</b> Feb 7 to March 22, May 6 to May 31 and June 19, 2011	<b>FCC ID:</b> L6ARDU70CW <b>IC:</b> 2503A-RDU70CW <b>FCC ID:</b> L6ARDV70UW <b>IC:</b> 2503A-RDV70UW

CDMA Conducted RF Emission Test Data cont'd

**The conducted spurious emissions** – As per 47 CFR 2.1051, CFR 24.238(a), CFR 4.202, CFR 22 Subpart H, RSS-132 and RSS - 133 were measured from 10 MHz to 20 GHz.

See figures 1-1b to 1-12b for the plots of the conducted spurious emissions.

Date of Test: Feb 25, 2011

***Test Data for Cellular and PCS selected Frequencies in Loopback mode***

Cellular Frequency (MHz)	99% Occupied Bandwidth (MHz)
824.700	1.273
836.520	1.273
848.310	1.280

PCS Frequency (MHz)	99% Occupied Bandwidth (MHz)
1851.200	1.273
1880.000	1.280
1908.750	1.273

***Test Data for Cellular and PCS selected Frequencies in Loopback mode***

Refer to the following measurement plots for more detail.

See Figures 1-1b to 1-12b for the plots of the conducted spurious emissions.

See Figures 1-13b to 1-18b for the plots of 99% Occupied Bandwidth.

See Figures 1-19b to 1-22b for the plots of the Channel mask.

The RF power output was at maximum for all the recorded measurements shown below.

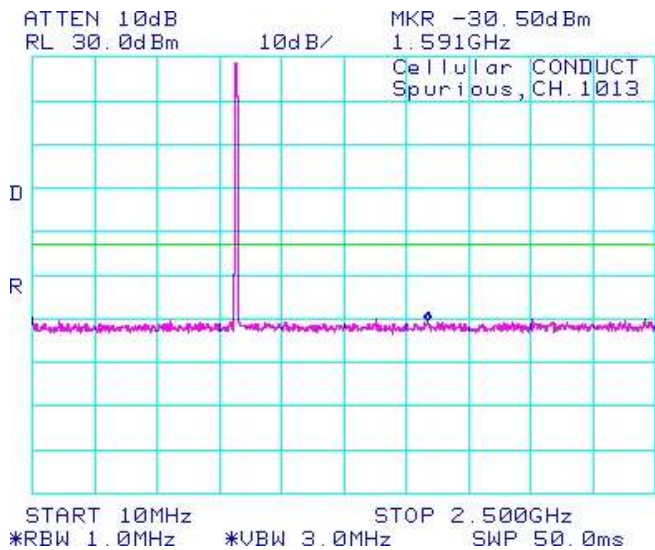
**Test Report No.**  
RTS-3933-1105-43B\_Rev1

**Dates of Test**  
Feb 7 to March 22, May 6 to May 31 and June 19, 2011

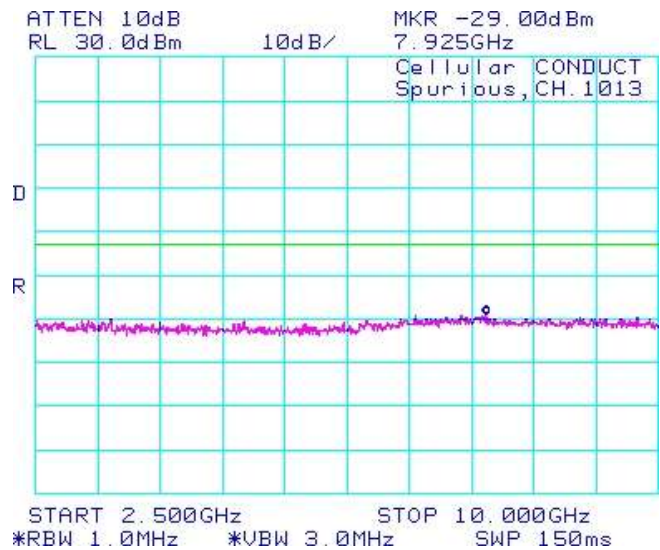
**FCC ID:** L6ARDU70CW **IC:** 2503A-RDU70CW  
**FCC ID:** L6ARDV70UW **IC:** 2503A-RDV70UW

CDMA Conducted RF Emission Test Data cont'd

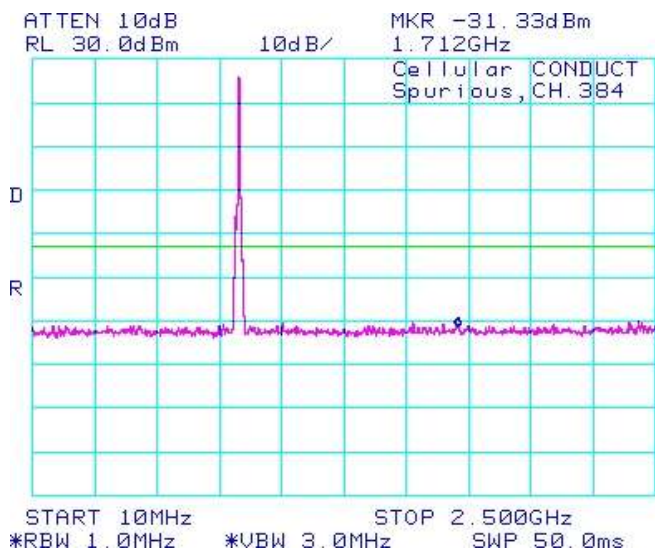
**Figure 1-1b: Cellular, Spurious Conducted Emissions, Low channel**



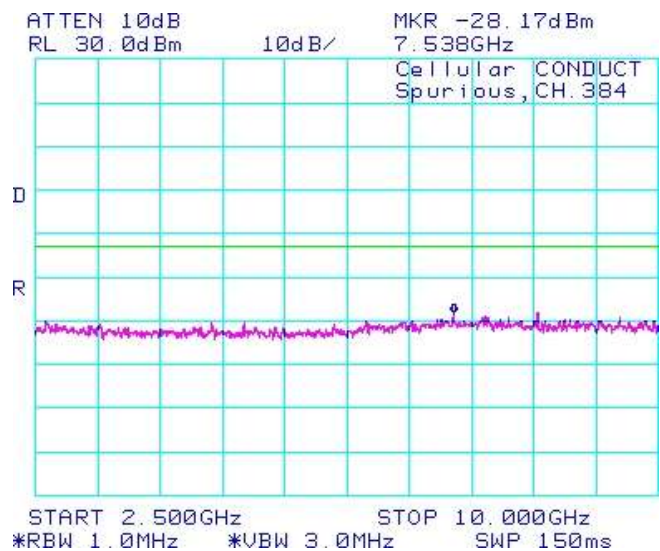
**Figure 1-2b: Cellular, Spurious Conducted Emissions, Low channel**



**Figure 1-3b: Cellular, Spurious Conducted Emissions, Middle channel**



**Figure 1-4b: Cellular, Spurious Conducted Emissions, Middle channel**



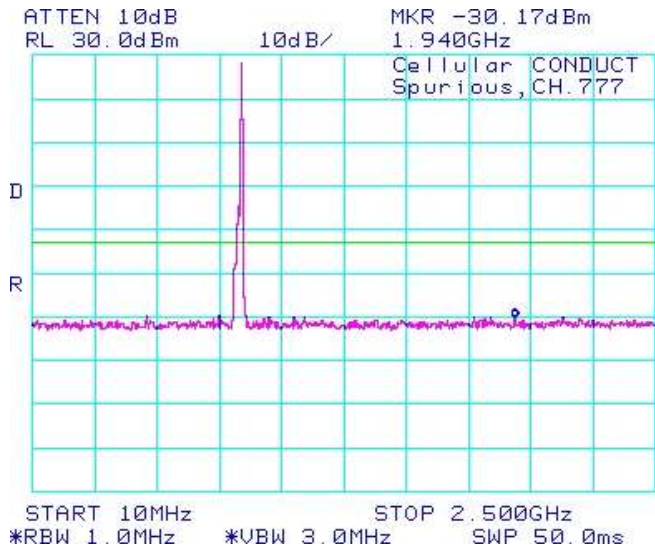
**Test Report No.**  
RTS-3933-1105-43B\_Rev1

**Dates of Test**  
Feb 7 to March 22, May 6 to May 31 and June 19, 2011

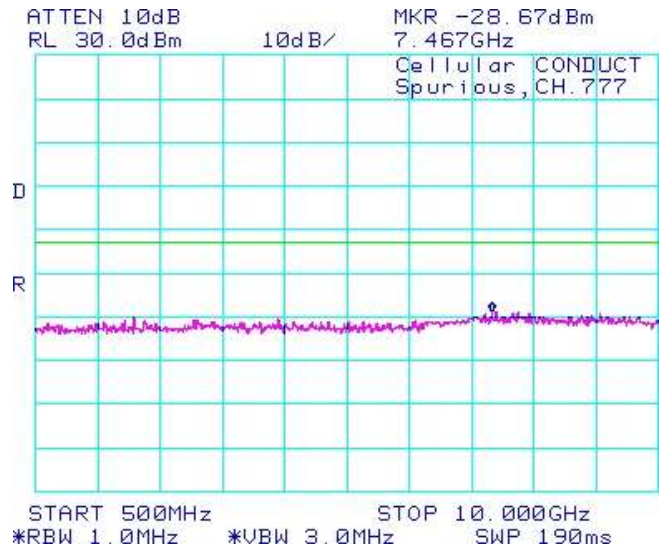
**FCC ID:** L6ARDU70CW **IC:** 2503A-RDU70CW  
**FCC ID:** L6ARDV70UW **IC:** 2503A-RDV70UW

**UMTS Conducted RF Emission Test Data cont'd**

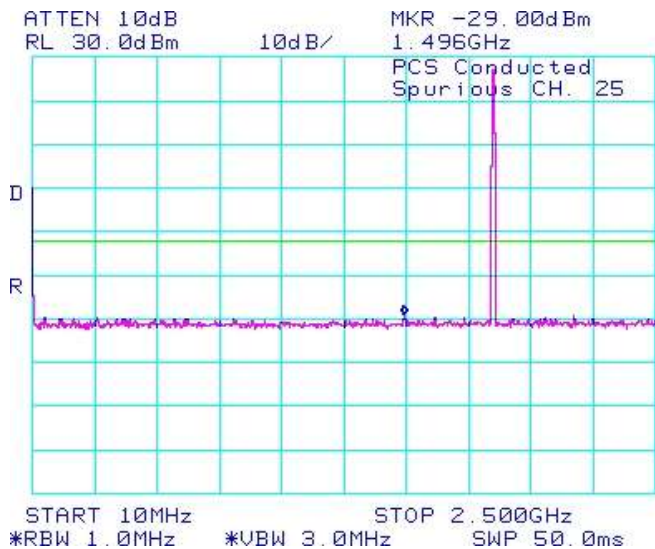
**Figure 7-5b: Cellular, Spurious Conducted Emissions, High Channel**



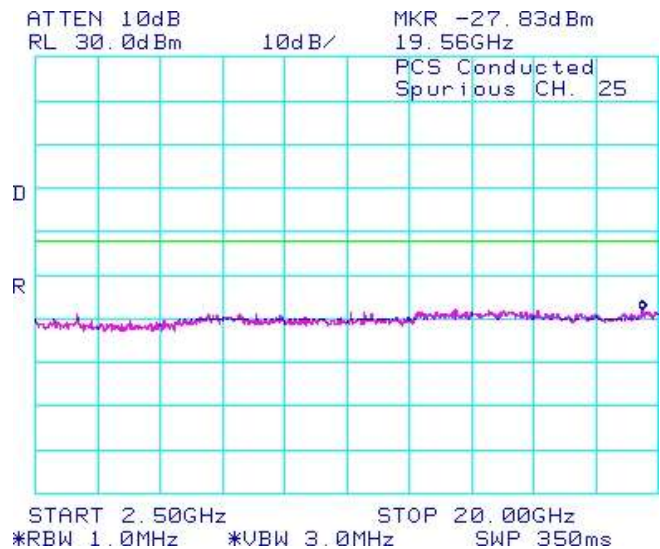
**Figure 1-6b: Cellular, Spurious Conducted Emissions, High Channel**



**Figure 1-7b: PCS, Spurious Conducted Emissions, Low Channel**



**Figure 1-8b: PCS, Spurious Conducted Emissions, Low Channel**



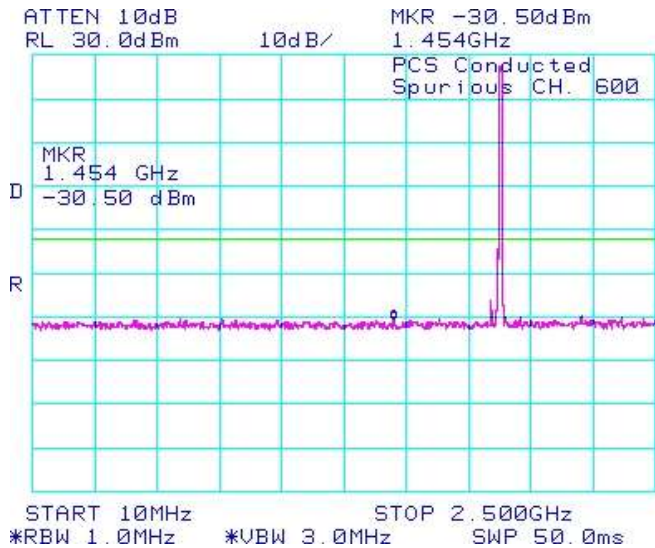
**Test Report No.**  
RTS-3933-1105-43B\_Rev1

**Dates of Test**  
Feb 7 to March 22, May 6 to May 31 and June 19, 2011

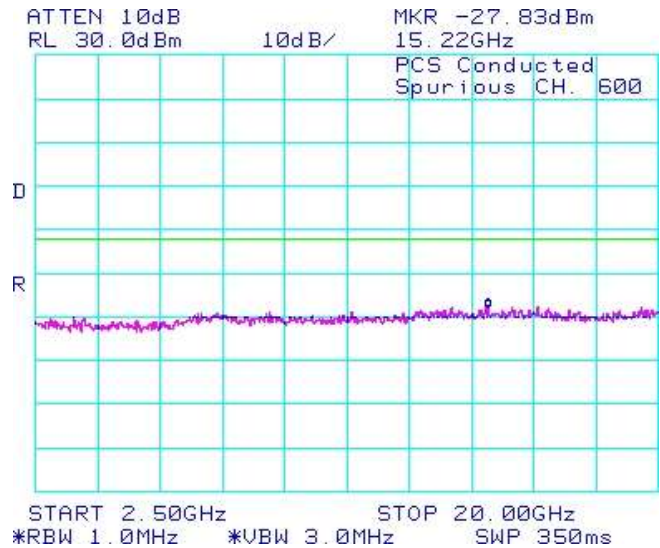
**FCC ID:** L6ARDU70CW **IC:** 2503A-RDU70CW  
**FCC ID:** L6ARDV70UW **IC:** 2503A-RDV70UW

CDMA Conducted RF Emission Test Data cont'd

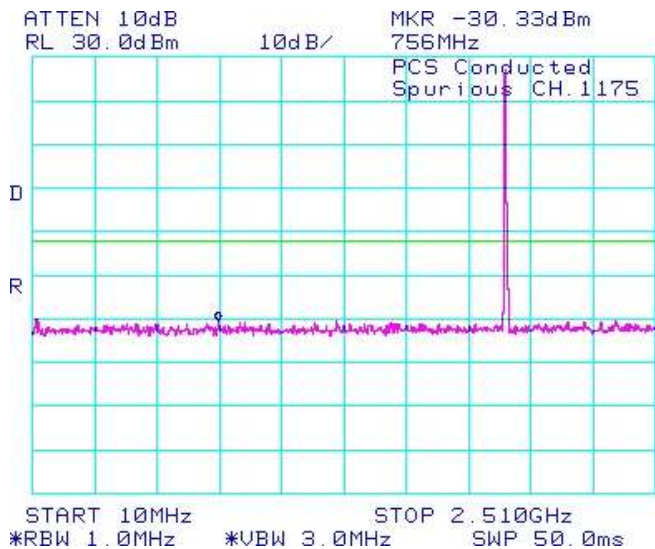
**Figure 1-9b: PCS, Spurious Conducted Emissions, Middle Channel**



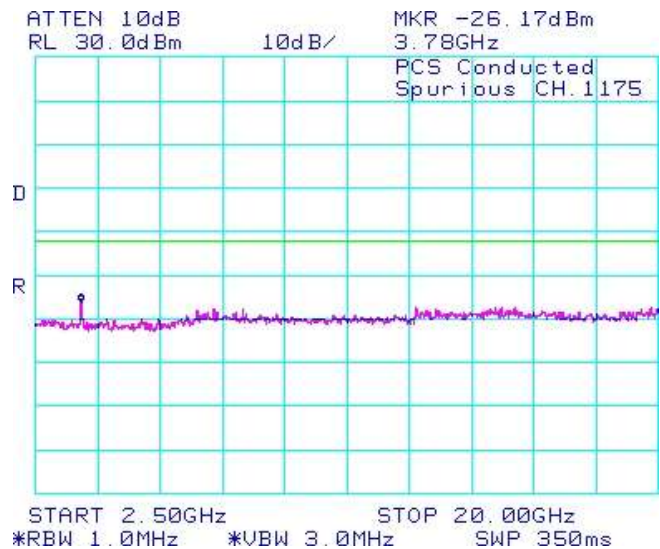
**Figure 1-10b: PCS, Spurious Conducted Emissions, Middle Channel**



**Figure 1-11b: PCS, Spurious Conducted Emissions, High Channel**



**Figure 1-12b: PCS, Spurious Conducted Emissions, High Channel**





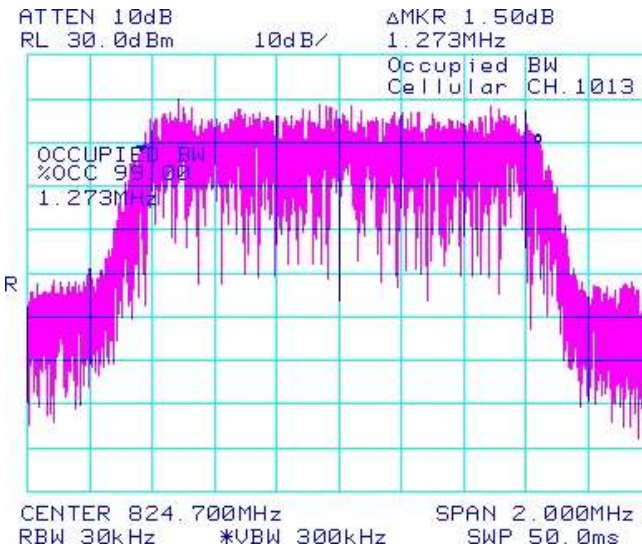
**Test Report No.**  
RTS-3933-1105-43B\_Rev1

**Dates of Test**  
Feb 7 to March 22, May 6 to May 31 and June 19, 2011

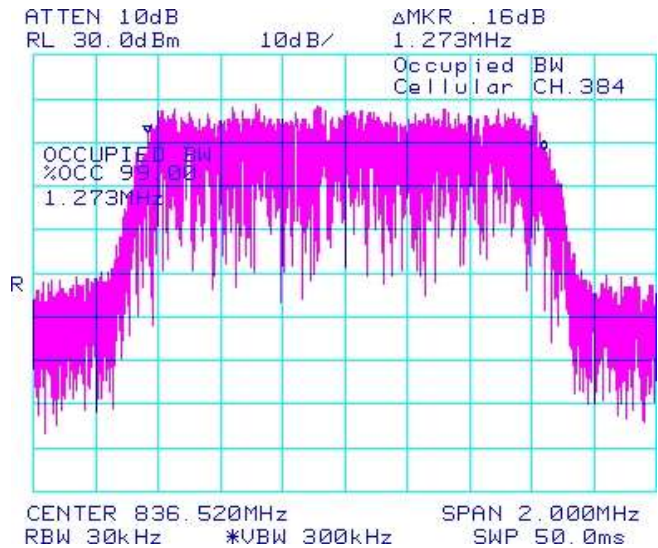
**FCC ID:** L6ARDU70CW **IC:** 2503A-RDU70CW  
**FCC ID:** L6ARDV70UW **IC:** 2503A-RDV70UW

CDMA Conducted RF Emission Test Data cont'd

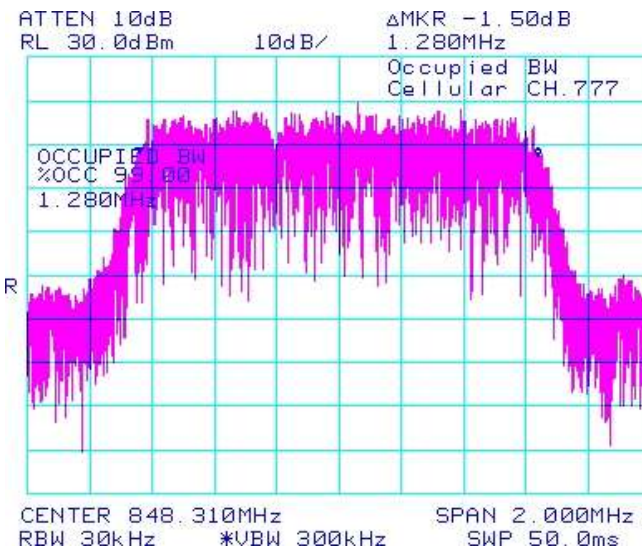
**Figure 1-13b: Occupied Bandwidth, Cellular Low Channel**



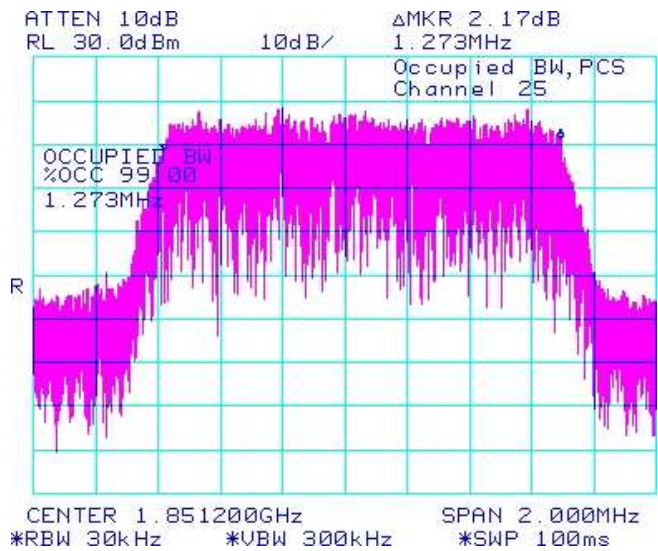
**Figure 1-14b: Occupied Bandwidth, Cellular Middle Channel**



**Figure 1-15b: Occupied Bandwidth, Cellular High Channel**



**Figure 1-16b: Occupied Bandwidth, PCS Low Channel**



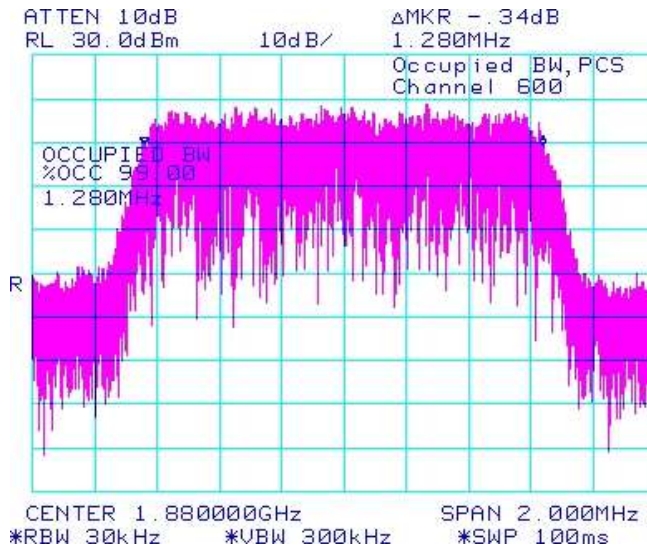
**Test Report No.**  
RTS-3933-1105-43B\_Rev1

**Dates of Test**  
Feb 7 to March 22, May 6 to May 31 and June 19, 2011

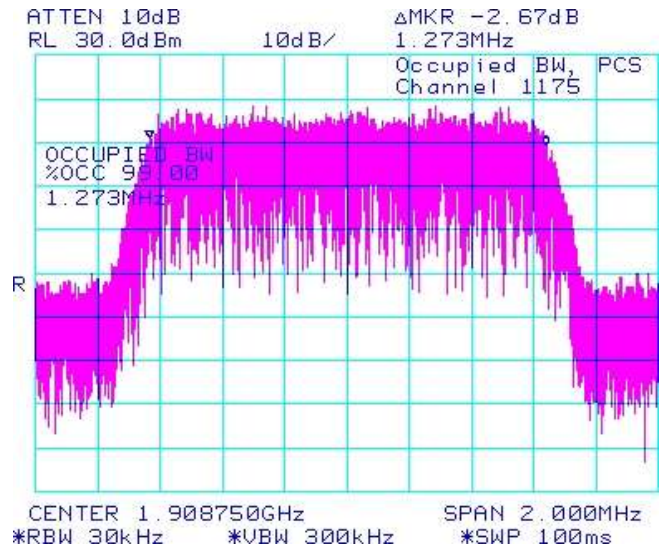
**FCC ID:** L6ARDU70CW **IC:** 2503A-RDU70CW  
**FCC ID:** L6ARDV70UW **IC:** 2503A-RDV70UW

CDMA Conducted RF Emission Test Data cont'd

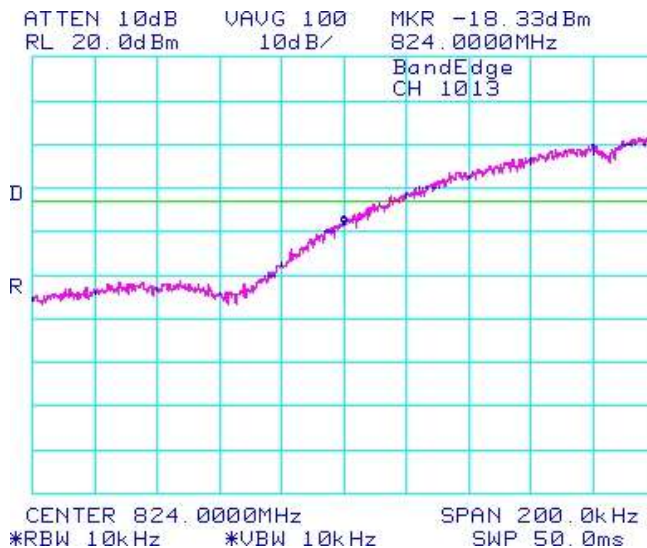
**Figure 1-17b: Occupied Bandwidth, PCS Middle Channel**



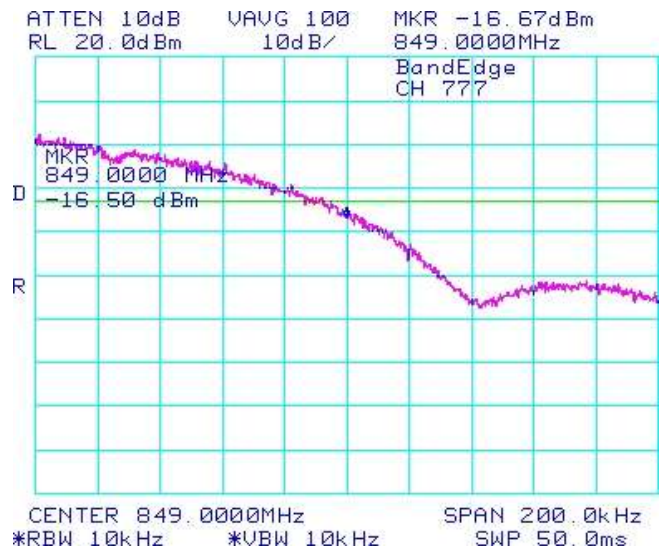
**Figure 1-18b: Occupied Bandwidth, PCS High Channel**



**Figure 1-19b: Cellular Low Channel Mask**



**Figure 1-20b: Cellular High Channel Mask**



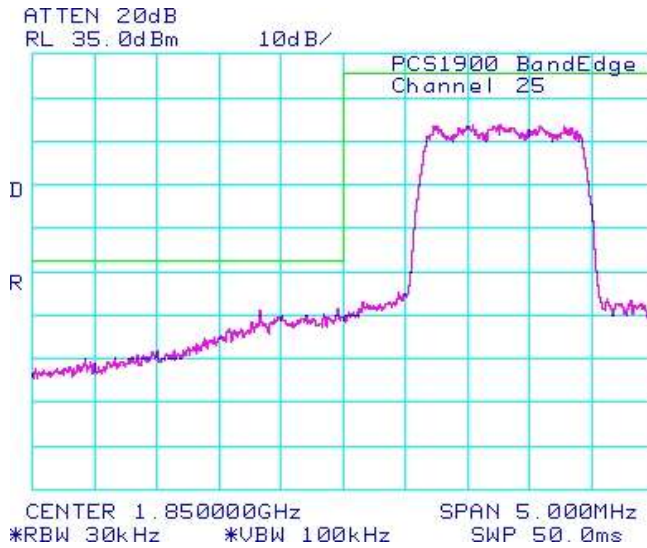
**Test Report No.**  
RTS-3933-1105-43B\_Rev1

**Dates of Test**  
Feb 7 to March 22, May 6 to May 31 and June 19, 2011

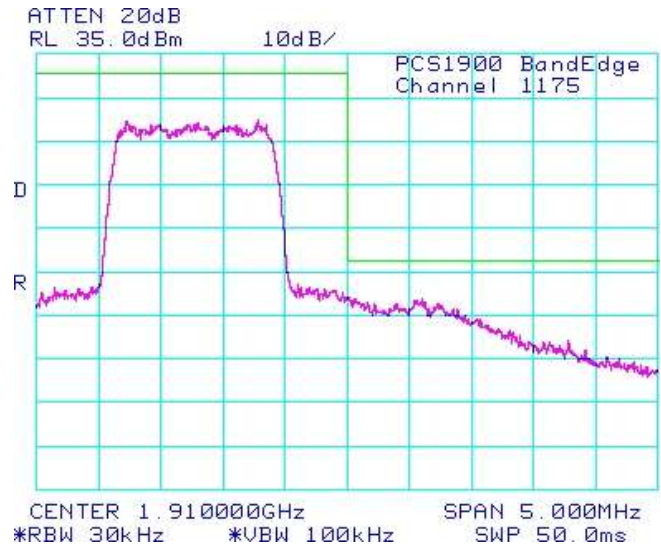
**FCC ID:** L6ARDU70CW **IC:** 2503A-RDU70CW  
**FCC ID:** L6ARDV70UW **IC:** 2503A-RDV70UW

CDMA Conducted RF Emission Test Data cont'd

**Figure 1-21b: PCS Low Channel Mask**



**Figure 1-22b: PCS High Channel Mask**





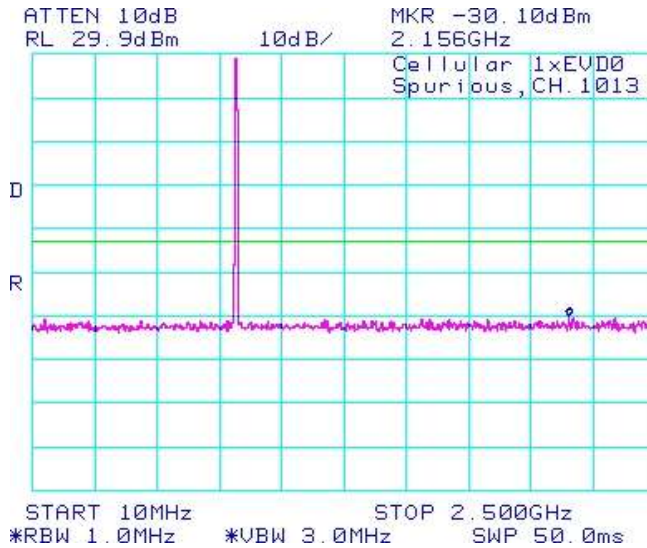
**Test Report No.**  
RTS-3933-1105-43B\_Rev1

**Dates of Test**  
Feb 7 to March 22, May 6 to May 31 and June 19, 2011

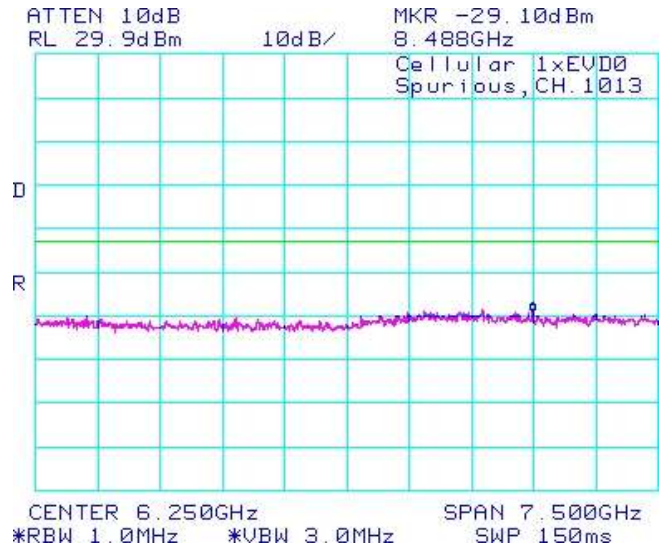
**FCC ID:** L6ARDU70CW **IC:** 2503A-RDU70CW  
**FCC ID:** L6ARDV70UW **IC:** 2503A-RDV70UW

CDMA EVDO Conducted RF Emission Test Data cont'd

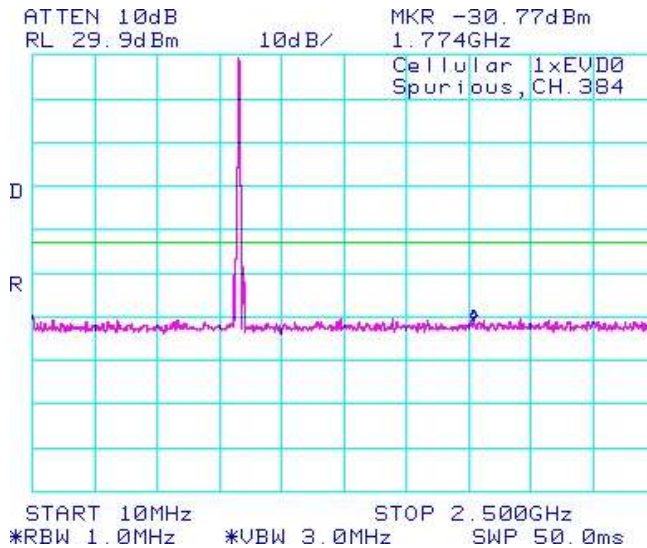
**Figure 1-23b: Cellular , Spurious Conducted Emissions, Low channel**



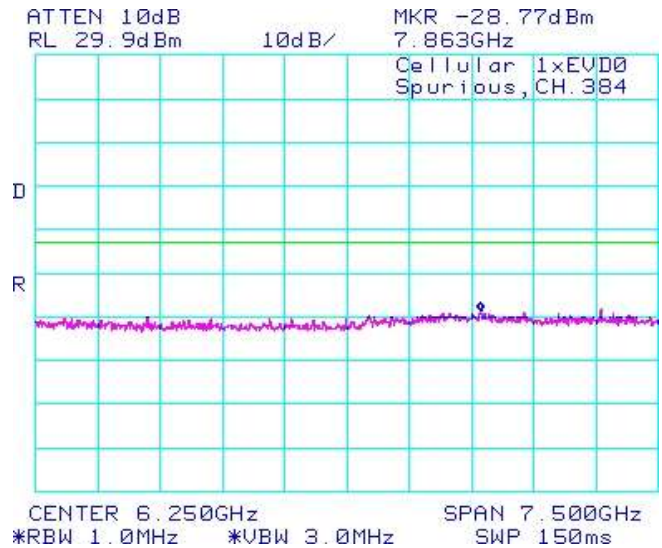
**Figure 1-24b: Cellular , Spurious Conducted Emissions, Low channel**



**Figure 1-25b: Cellular , Spurious Conducted Emissions, Middle channel**



**Figure 1-26b: Cellular , Spurious Conducted Emissions, Middle channel**



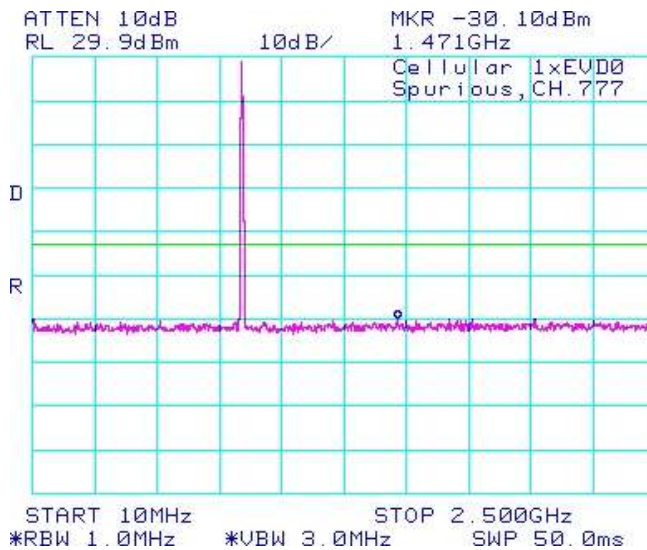
**Test Report No.**  
RTS-3933-1105-43B\_Rev1

**Dates of Test**  
Feb 7 to March 22, May 6 to May 31 and June 19, 2011

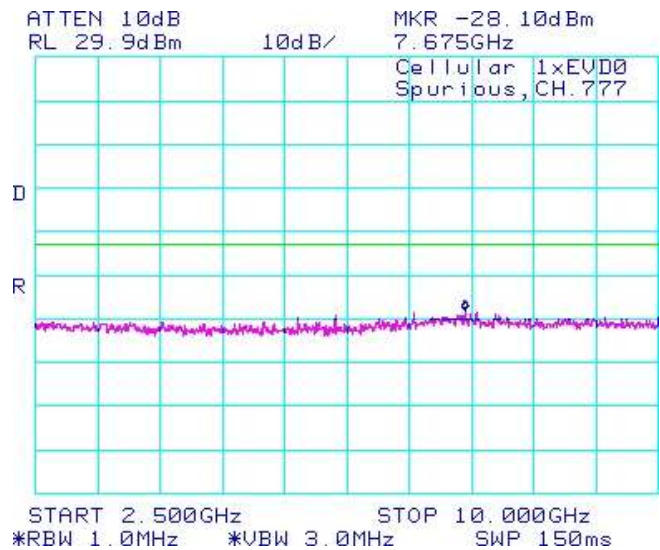
**FCC ID:** L6ARDU70CW **IC:** 2503A-RDU70CW  
**FCC ID:** L6ARDV70UW **IC:** 2503A-RDV70UW

CDMA Conducted RF Emission Test Data cont'd

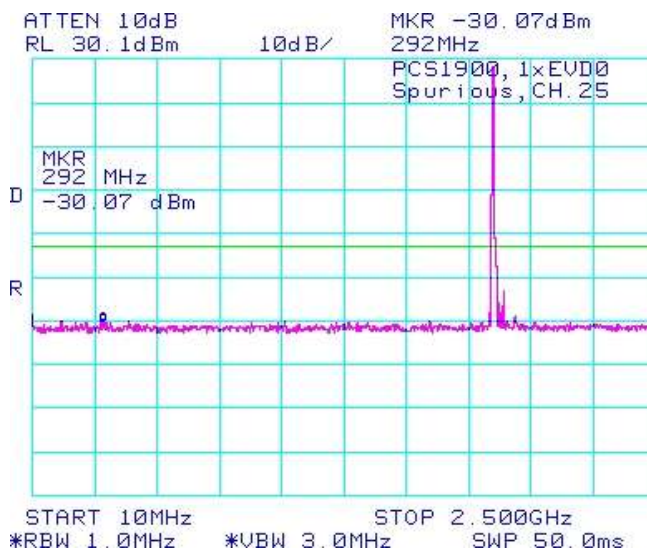
**Figure 8-27b: Cellular , Spurious Conducted Emissions, High Channel**



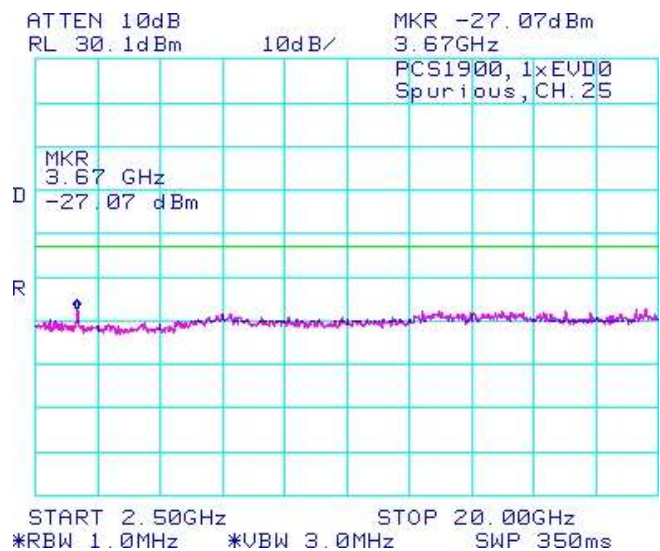
**Figure 1-28b: Cellular , Spurious Conducted Emissions, High Channel**



**Figure 1-29b: CDMA PCS, Spurious Conducted Emissions, Low Channel**



**Figure 1-30b: CDMA PCS, Spurious Conducted Emissions, Low Channel**



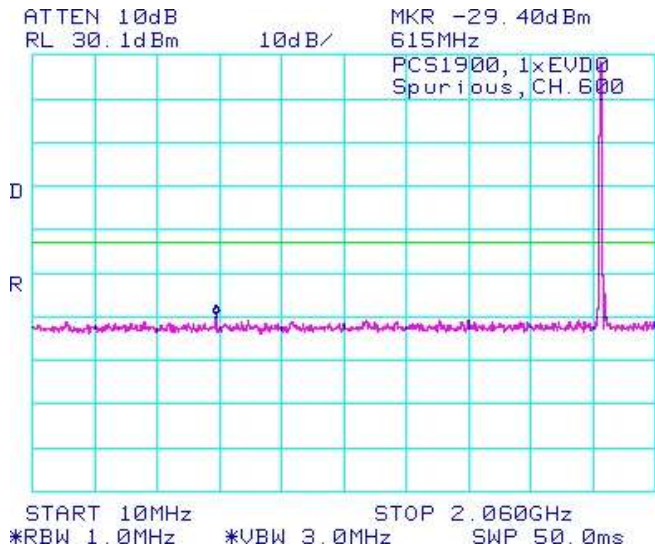
**Test Report No.**  
RTS-3933-1105-43B\_Rev1

**Dates of Test**  
Feb 7 to March 22, May 6 to May 31 and June 19, 2011

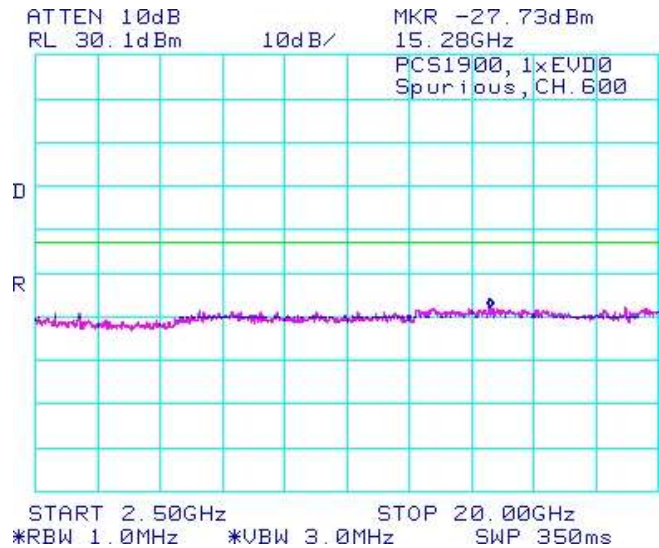
**FCC ID:** L6ARDU70CW **IC:** 2503A-RDU70CW  
**FCC ID:** L6ARDV70UW **IC:** 2503A-RDV70UW

CDMA Conducted RF Emission Test Data cont'd

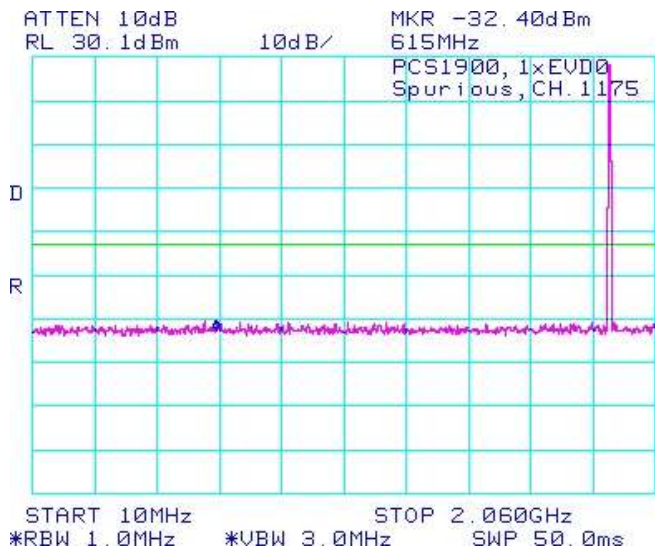
**Figure 1-31b: CDMA PCS, Spurious Conducted Emissions, Middle Channel**



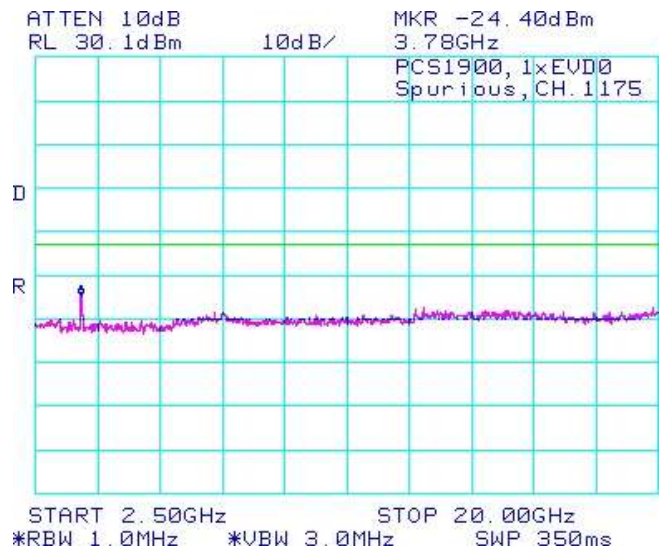
**Figure 1-32b: CDMA PCS, Spurious Conducted Emissions, Middle Channel**



**Figure 1-33b: CDMA PCS, Spurious Conducted Emissions, High Channel**



**Figure 1-34b: CDMA PCS, Spurious Conducted Emissions, High Channel**



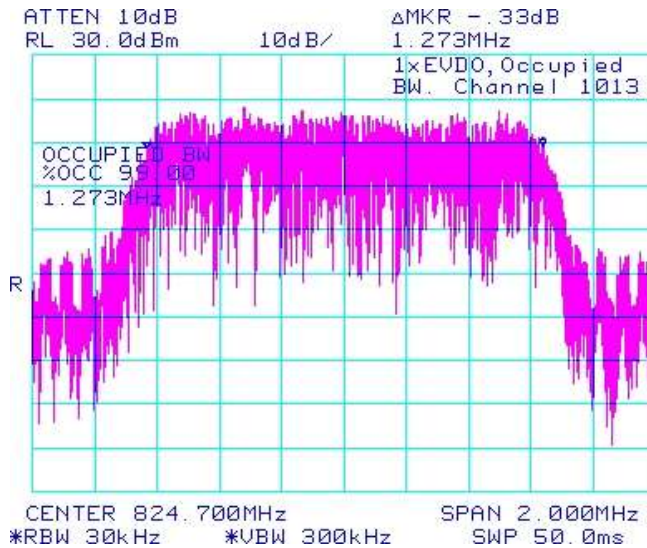
**Test Report No.**  
RTS-3933-1105-43B\_Rev1

**Dates of Test**  
Feb 7 to March 22, May 6 to May 31 and June 19, 2011

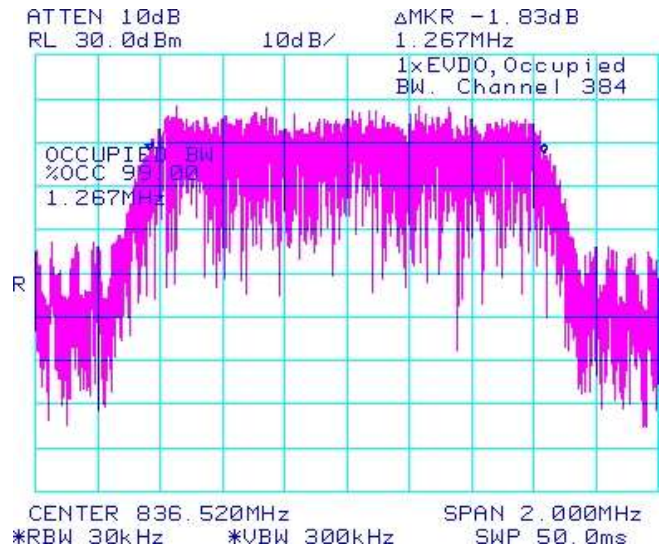
**FCC ID:** L6ARDU70CW **IC:** 2503A-RDU70CW  
**FCC ID:** L6ARDV70UW **IC:** 2503A-RDV70UW

CDMA Conducted RF Emission Test Data cont'd

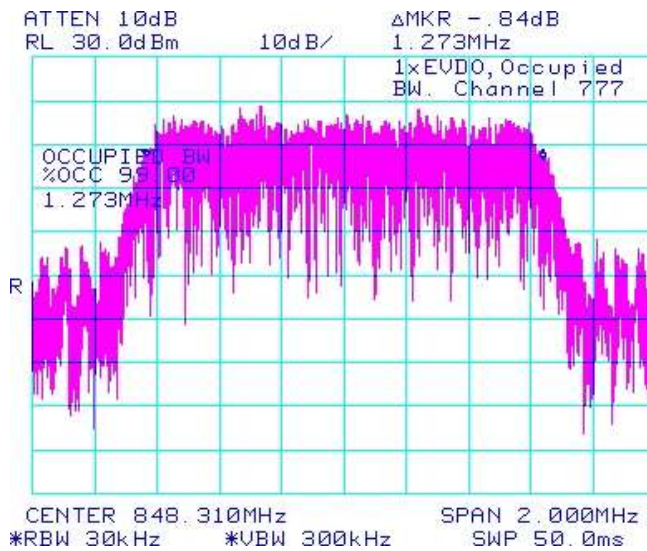
**Figure 1-35b: Occupied Bandwidth, Cellular Low Channel**



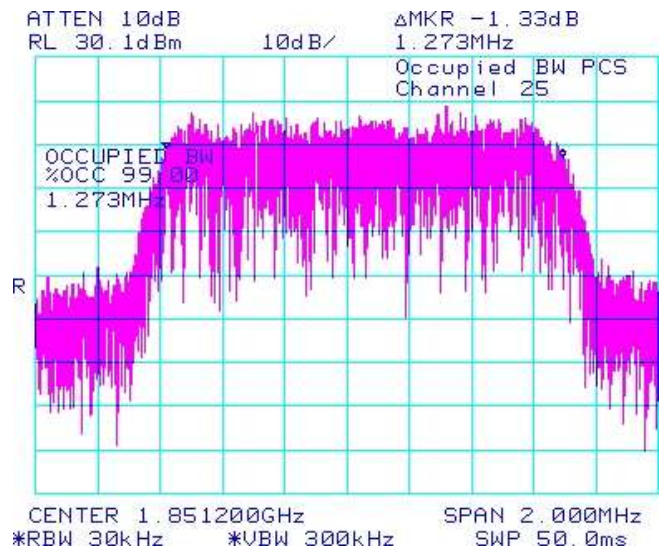
**Figure 1-36b: Occupied Bandwidth, Cellular Middle Channel**



**Figure 1-37b: Occupied Bandwidth, Cellular High Channel**



**Figure 1-38b: Occupied Bandwidth, PCS Low Channel**





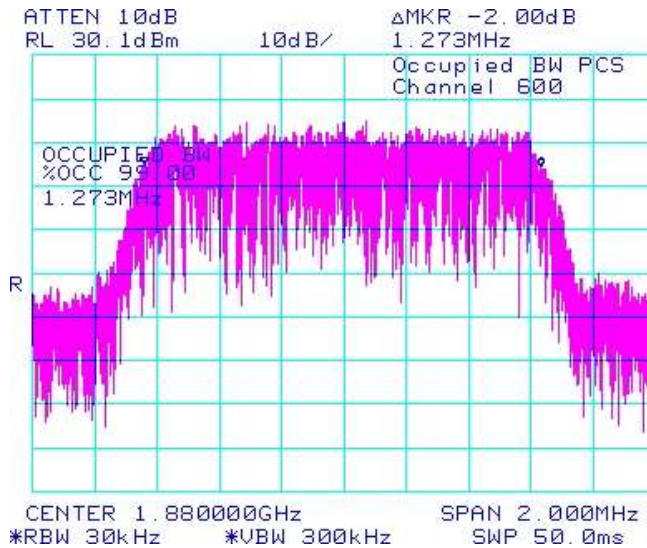
**Test Report No.**  
RTS-3933-1105-43B\_Rev1

**Dates of Test**  
Feb 7 to March 22, May 6 to May 31 and June 19, 2011

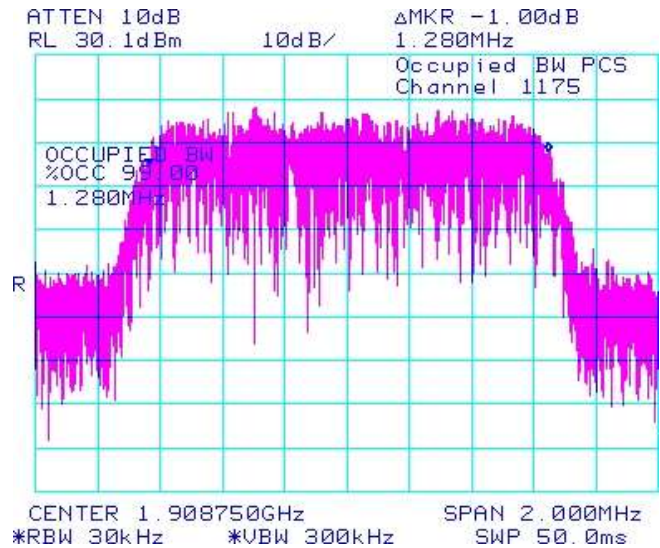
**FCC ID:** L6ARDU70CW **IC:** 2503A-RDU70CW  
**FCC ID:** L6ARDV70UW **IC:** 2503A-RDV70UW

CDMA Conducted RF Emission Test Data cont'd

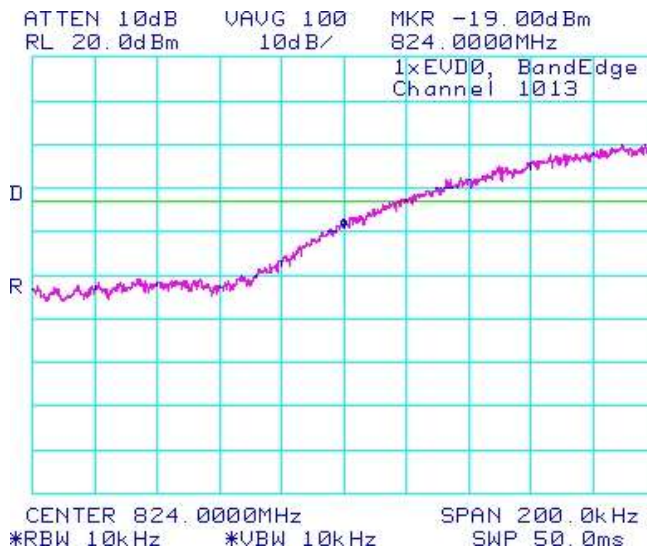
**Figure 1-38b: Occupied Bandwidth, PCS Middle Channel**



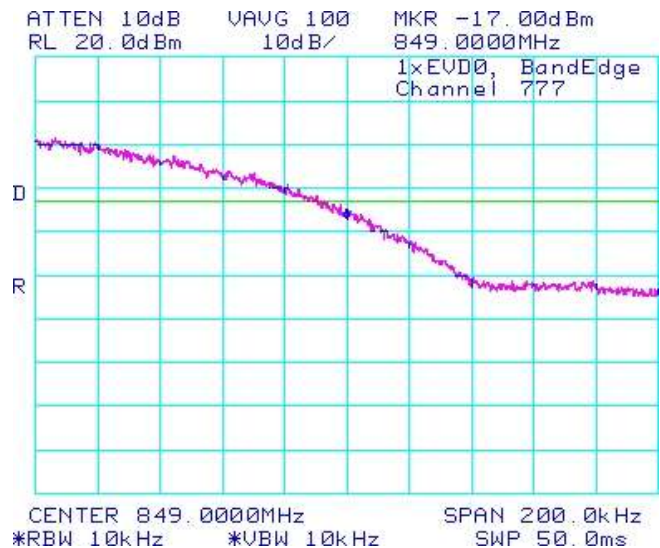
**Figure 1-39b: Occupied Bandwidth, PCS High Channel**



**Figure 1-40b: Cellular , Low Channel Mask**



**Figure 1-41b: Cellular , High Channel Mask**



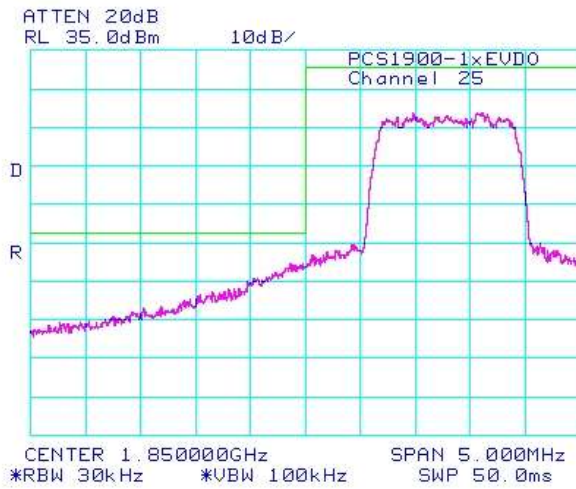
**Test Report No.**  
RTS-3933-1105-43B\_Rev1

**Dates of Test**  
Feb 7 to March 22, May 6 to May 31 and June 19, 2011

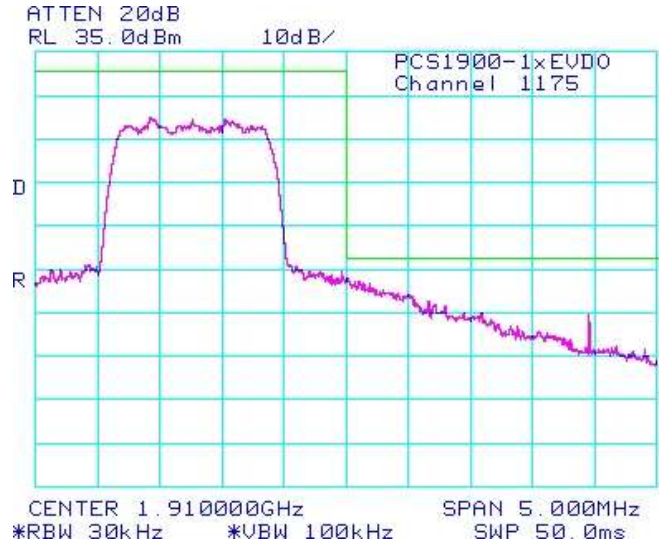
**FCC ID:** L6ARDU70CW **IC:** 2503A-RDU70CW  
**FCC ID:** L6ARDV70UW **IC:** 2503A-RDV70UW

CDMA Conducted RF Emission Test Data cont'd


**Figure 1-42b: CDMA PCS, Low Channel Mask**



**Figure 1-43b: CDMA PCS, High Channel Mask**



## APPENDIX 1C– UMTS CONDUCTED RF EMISSIONS TEST DATA/PLOTS

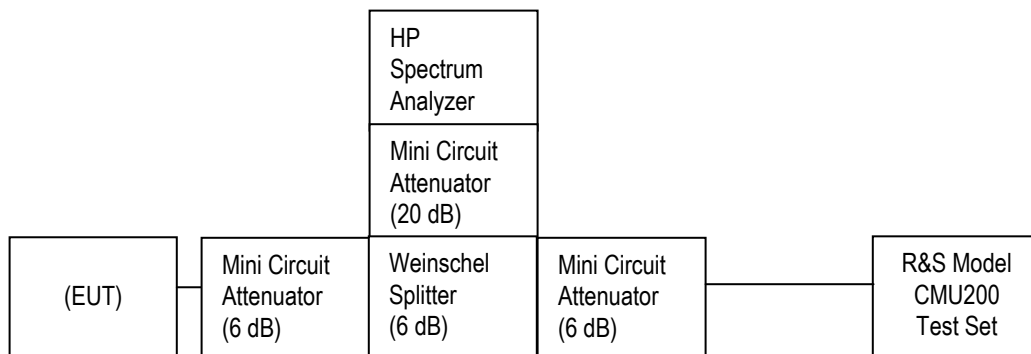
	EMI Test Report for the BlackBerry® smartphone Model RDU71CW, RDV71UW APPENDIX 1C	
<b>Test Report No.</b> RTS-3933-1105-43B_Rev1	<b>Dates of Test</b> Feb 7 to March 22, May 6 to May 31 and June 19, 2011	<b>FCC ID:</b> L6ARDU70CW <b>IC:</b> 2503A-RDU70CW <b>FCC ID:</b> L6ARDV70UW <b>IC:</b> 2503A-RDV70UW

### UMTS Conducted RF Emission Test Data


The following test configurations were measured for model RDV71UW:

This appendix contains measurement data pertaining to conducted spurious emissions, 99% power bandwidth and the channel mask.

### **Test Setup Diagram**



The environmental test conditions were: Temperature: 24 °C  
Relative Humidity: 44.3 %

	EMI Test Report for the BlackBerry® smartphone Model RDU71CW, RDV71UW APPENDIX 1C	
<b>Test Report No.</b> RTS-3933-1105-43B_Rev1	<b>Dates of Test</b> Feb 7 to March 22, May 6 to May 31 and June 19, 2011	<b>FCC ID:</b> L6ARDU70CW <b>IC:</b> 2503A-RDU70CW <b>FCC ID:</b> L6ARDV70UW <b>IC:</b> 2503A-RDV70UW

UMTS Conducted RF Emission Test Data cont'd

**The conducted spurious emissions** – As per 47 CFR 2.1051, CFR 24.238(a), CFR 4.202, CFR 22 Subpart H, RSS-132 and RSS - 133 were measured from 10 MHz to 20 GHz.

See figures 1-1c to 1-11c for the plots of the conducted spurious emissions.

Date of Test: June 10, 2011

***Test Data UMTS Band 4 selected Frequencies in Call mode***

UMTS band 4 Frequency (MHz)	26dBc Occupied Bandwidth (MHz)	99% Occupied Bandwidth (MHz)
1712.400	4.600	4.167
1732.600	4.617	4.150
1752.600	4.600	4.150

***Test Data for UMTS band 4 selected Frequencies in Call mode***

Refer to the following measurement plots for more detail.

See Figures 1-1c to 1-6c for the plots of the conducted spurious emissions.

See Figures 1-7c to 1-9c for the plots of 99% Occupied Bandwidth.

See Figures 1-10c to 1-11c for the plots of the Channel mask.

The RF power output was at maximum for all the recorded measurements shown below.

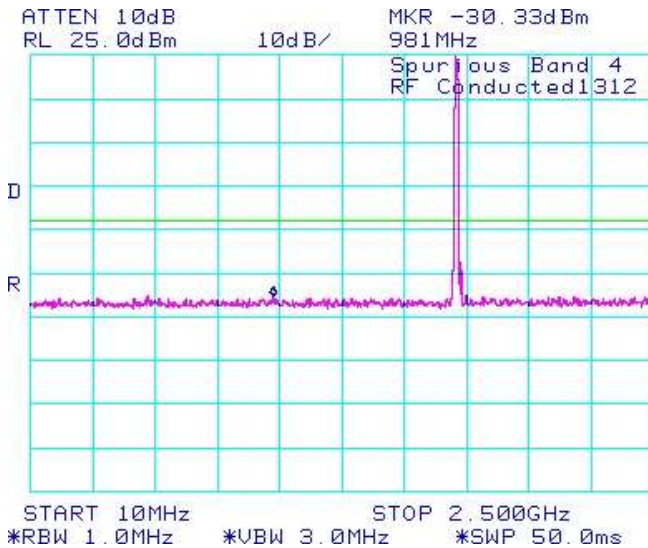
**Test Report No.**  
RTS-3933-1105-43B\_Rev1

**Dates of Test**  
Feb 7 to March 22, May 6 to May 31 and June 19, 2011

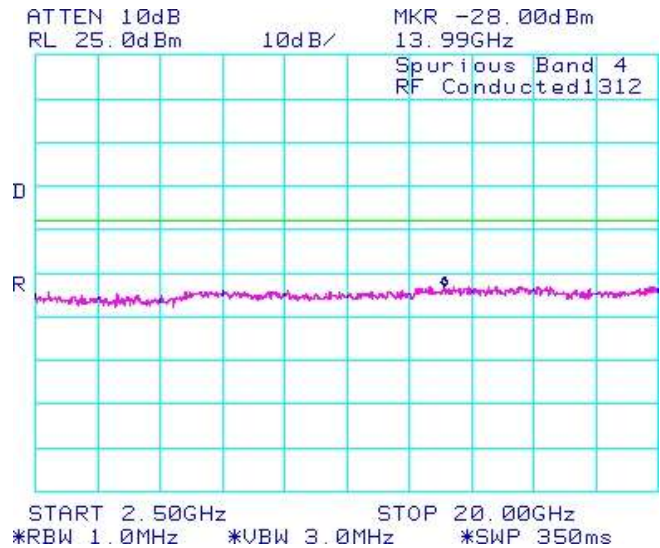
**FCC ID:** L6ARDU70CW **IC:** 2503A-RDU70CW  
**FCC ID:** L6ARDV70UW **IC:** 2503A-RDV70UW

**UMTS Conducted RF Emission Test Data cont'd**

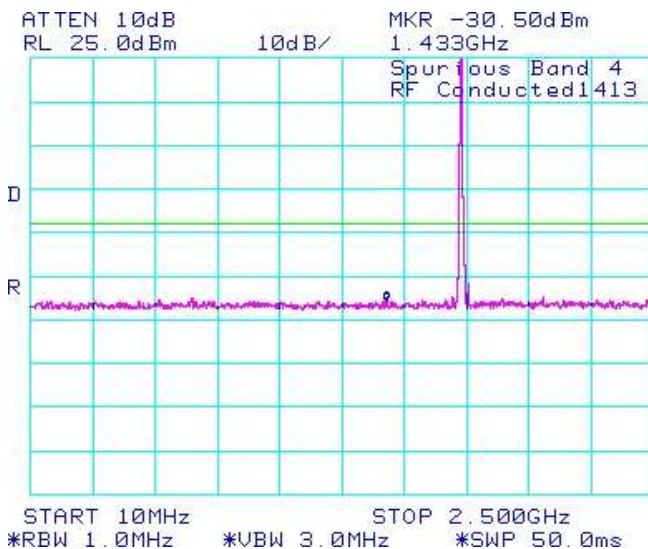
**Figure 1-1c: Band 4, Spurious Conducted Emissions, Low channel**



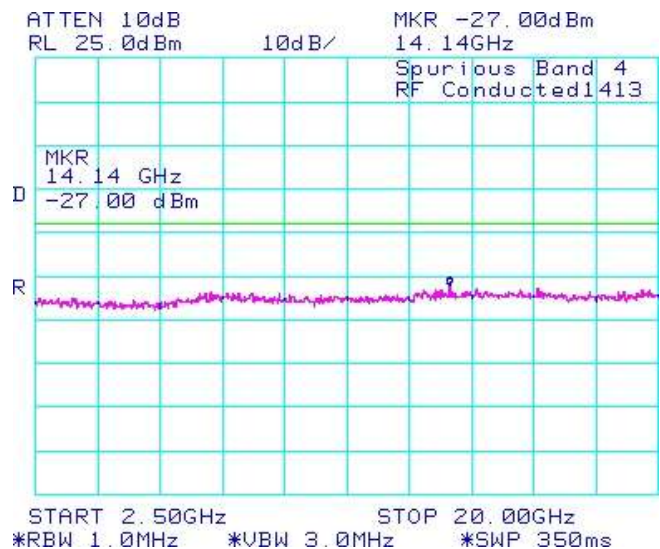
**Figure 1-2c: Band 4, Spurious Conducted Emissions, Low channel**



**Figure 1-3c: Band 4, Spurious Conducted Emissions, Middle channel**



**Figure 1-4c: Band 4, Spurious Conducted Emissions, Middle channel**



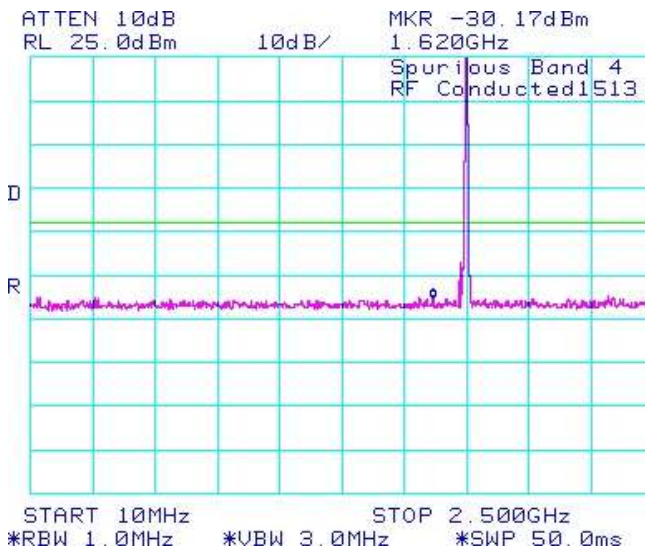
**Test Report No.**  
RTS-3933-1105-43B\_Rev1

**Dates of Test**  
Feb 7 to March 22, May 6 to May 31 and June 19, 2011

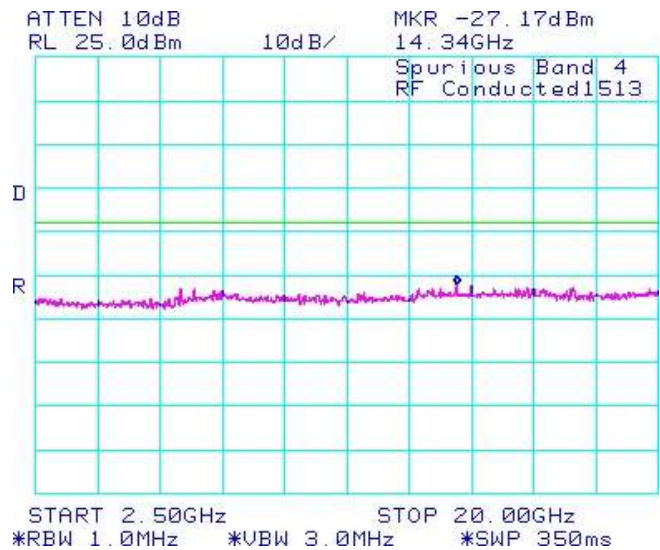
**FCC ID:** L6ARDU70CW **IC:** 2503A-RDU70CW  
**FCC ID:** L6ARDV70UW **IC:** 2503A-RDV70UW

UMTS Conducted RF Emission Test Data cont'd

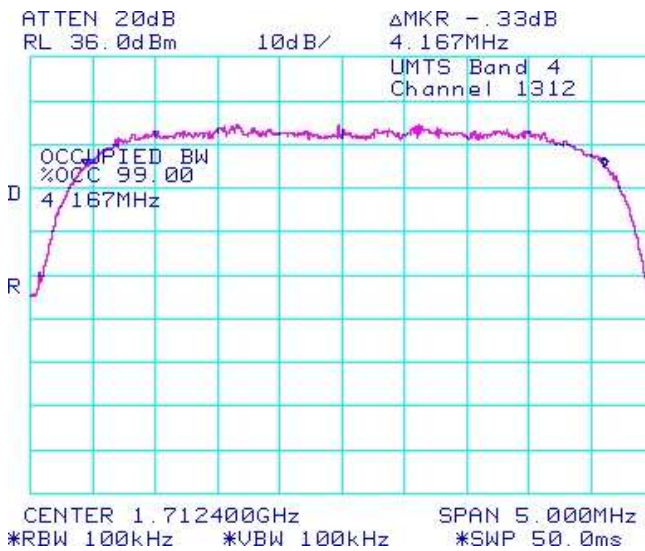
**Figure 1-5c: Band 4, Spurious Conducted Emissions, High channel**



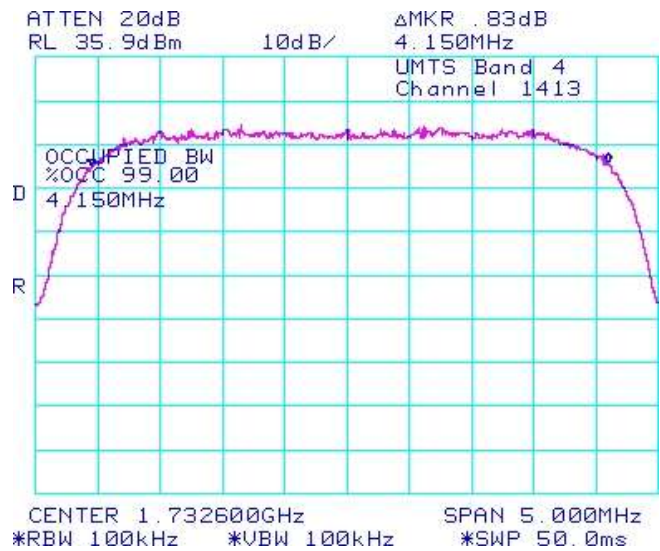
**Figure 1-6c: Band 4, Spurious Conducted Emissions, High channel**




**Figure 1-7c: Occupied Bandwidth, Band 4 Low Channel**



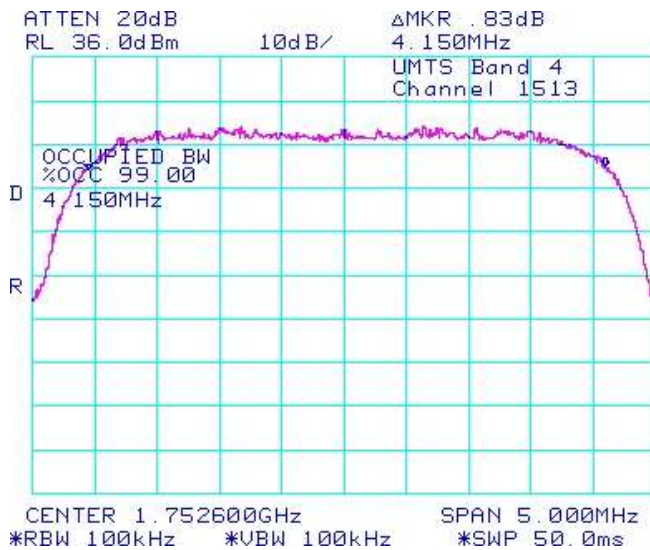
**Figure 1-8c: Occupied Bandwidth, Band 4 Middle Channel**



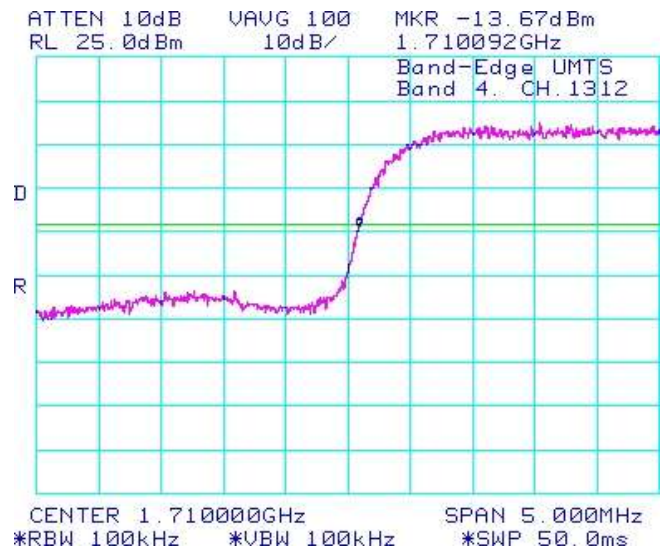
	EMI Test Report for the BlackBerry® smartphone Model RDU71CW, RDV71UW APPENDIX 1C	
<b>Test Report No.</b> RTS-3933-1105-43B_Rev1	<b>Dates of Test</b> Feb 7 to March 22, May 6 to May 31 and June 19, 2011	<b>FCC ID:</b> L6ARDU70CW <b>IC:</b> 2503A-RDU70CW <b>FCC ID:</b> L6ARDV70UW <b>IC:</b> 2503A-RDV70UW

UMTS Conducted RF Emission Test Data cont'd

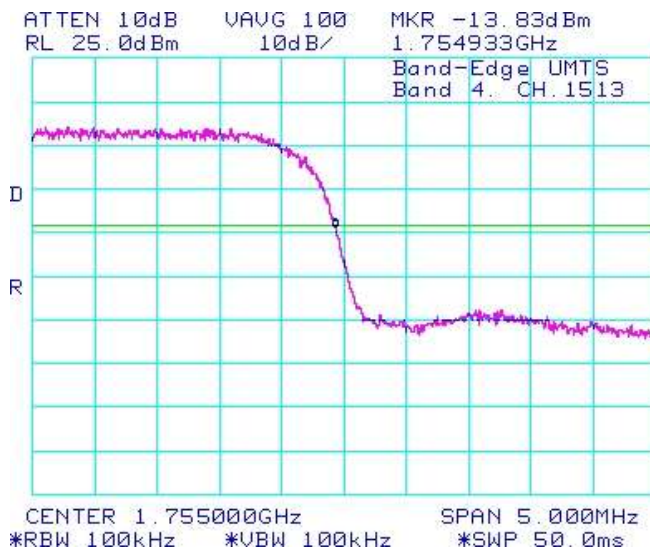
**Figure 1-9c: Occupied Bandwidth, Band 4 High Channel**



**Figure 1-10c: Band 4 Low Channel Mask**




**Figure 1-11c: Band 4 High Channel Mask**



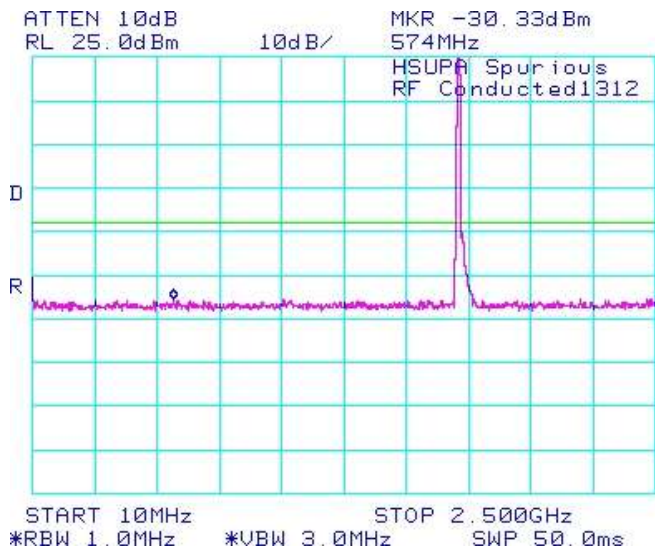




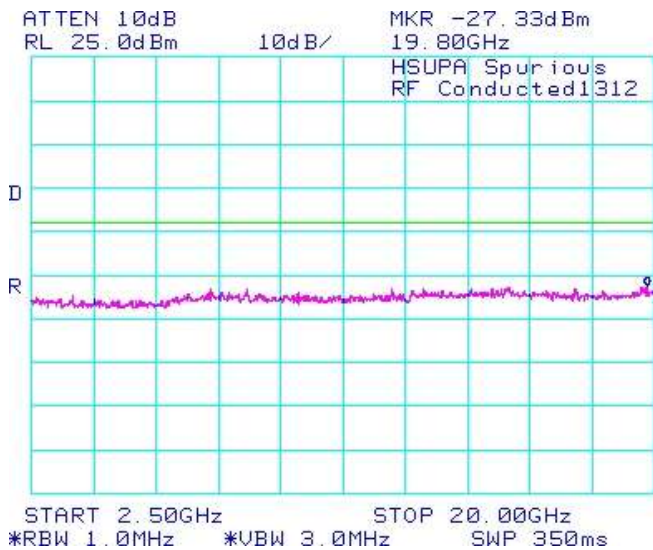
	EMI Test Report for the BlackBerry® smartphone Model RDU71CW, RDV71UW APPENDIX 1C	
<b>Test Report No.</b> RTS-3933-1105-43B_Rev1	<b>Dates of Test</b> Feb 7 to March 22, May 6 to May 31 and June 19, 2011	<b>FCC ID:</b> L6ARDU70CW <b>IC:</b> 2503A-RDU70CW <b>FCC ID:</b> L6ARDV70UW <b>IC:</b> 2503A-RDV70UW

### UMTS Conducted RF Emission Test Data cont'd

**Figure 1-23b: Band 4 , Spurious Conducted Emissions, Low channel**



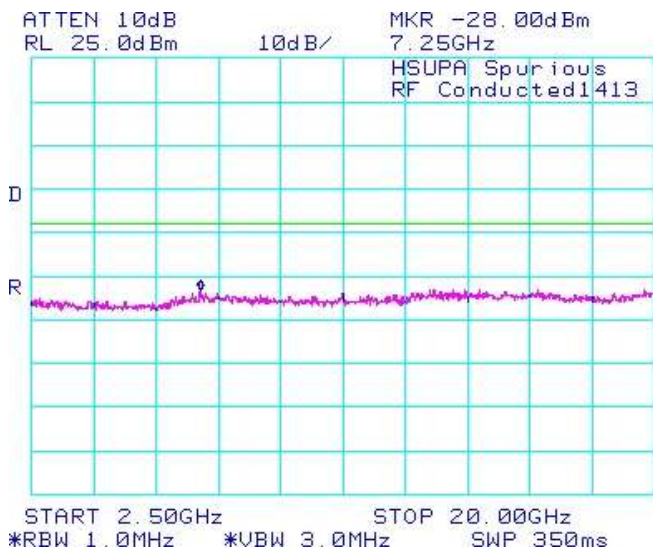
**Figure 1-24b: Band 4 , Spurious Conducted Emissions, Low channel**




**Figure 1-25b: Band 4 , Spurious Conducted Emissions, Middle channel**



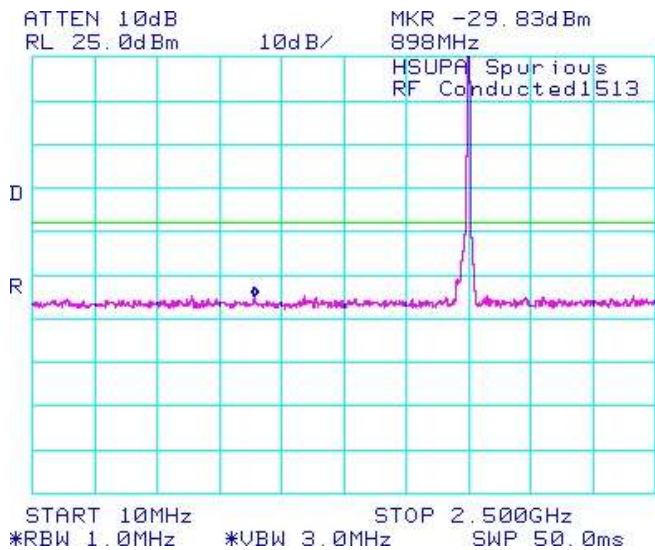
**Figure 1-26b: Band 4 , Spurious Conducted Emissions, Middle channel**



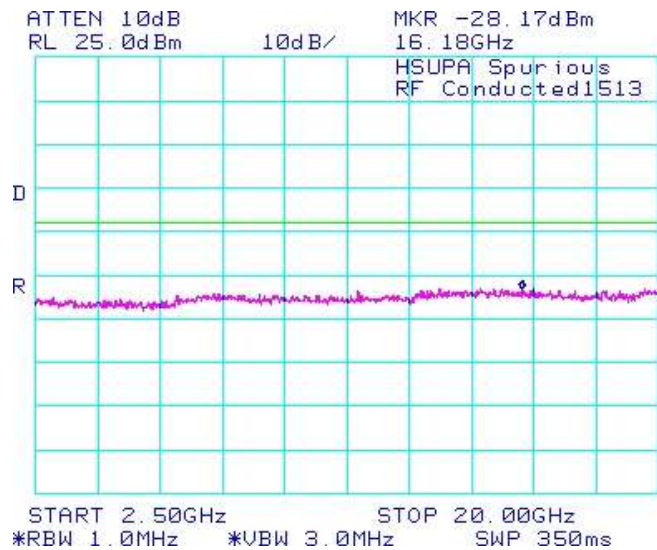
	EMI Test Report for the BlackBerry® smartphone Model RDU71CW, RDV71UW APPENDIX 1C	
<b>Test Report No.</b> RTS-3933-1105-43B_Rev1	<b>Dates of Test</b> Feb 7 to March 22, May 6 to May 31 and June 19, 2011	<b>FCC ID:</b> L6ARDU70CW <b>IC:</b> 2503A-RDU70CW <b>FCC ID:</b> L6ARDV70UW <b>IC:</b> 2503A-RDV70UW

### UMTS Conducted RF Emission Test Data cont'd

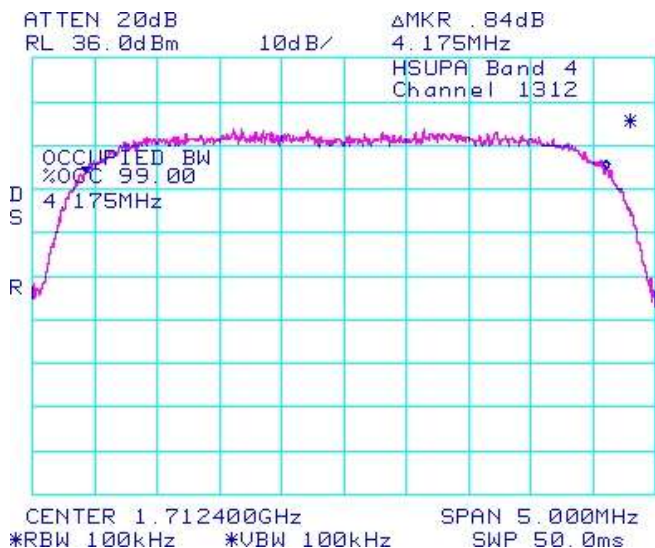
**Figure 1-27b: Band 4 , Spurious Conducted Emissions, High Channel**



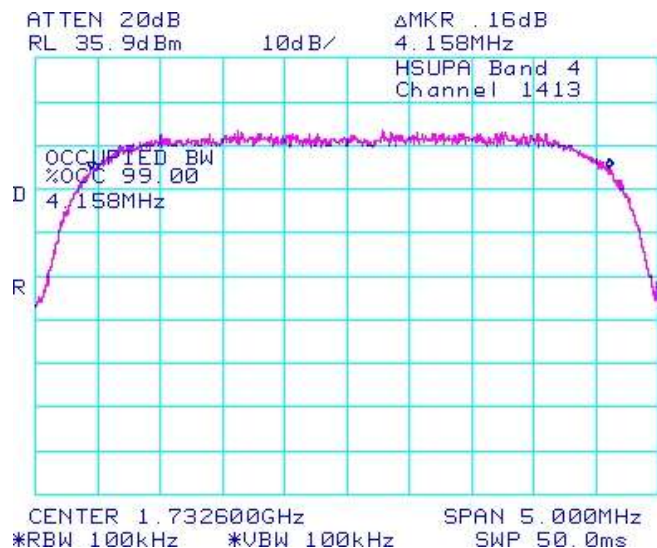
**Figure 1-28b: Band 4 , Spurious Conducted Emissions, High Channel**



**Figure 1-29b: Occupied Bandwidth, Band 4 Low Channel**

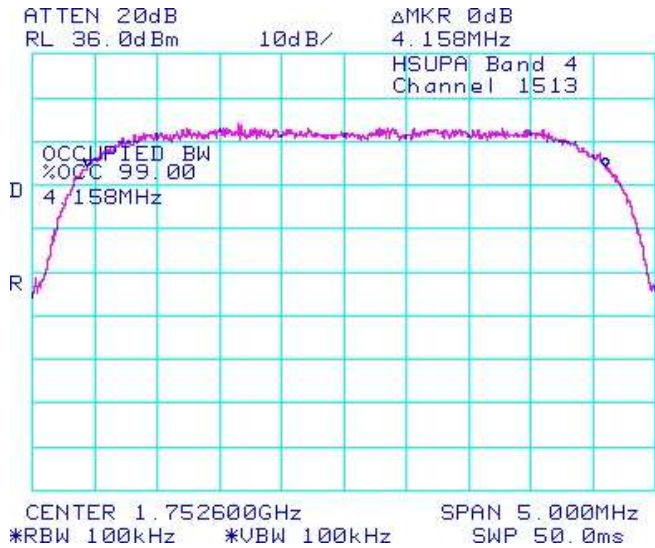


**Figure 1-30b: Occupied Bandwidth, Band 4 Middle Channel**



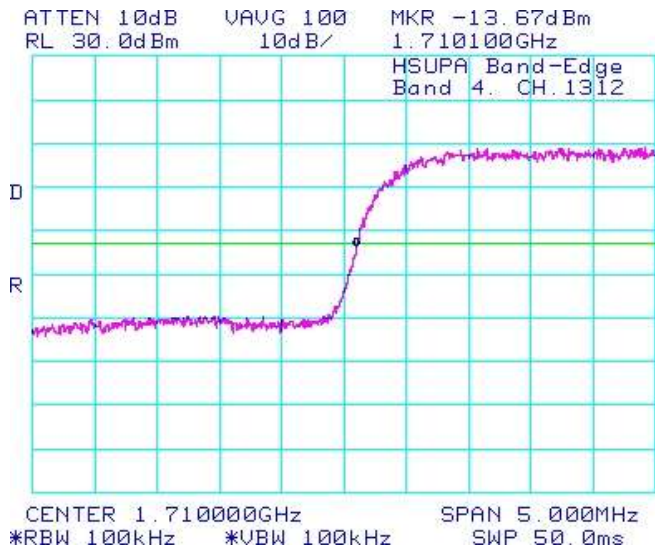
<b>Test Report No.</b> RTS-3933-1105-43B_Rev1	<b>Dates of Test</b> Feb 7 to March 22, May 6 to May 31 and June 19, 2011	<b>FCC ID:</b> L6ARDU70CW <b>IC:</b> 2503A-RDU70CW <b>FCC ID:</b> L6ARDV70UW <b>IC:</b> 2503A-RDV70UW
--	--	--

**Figure 1-31b: Occupied Bandwidth, Band 4 High Channel**

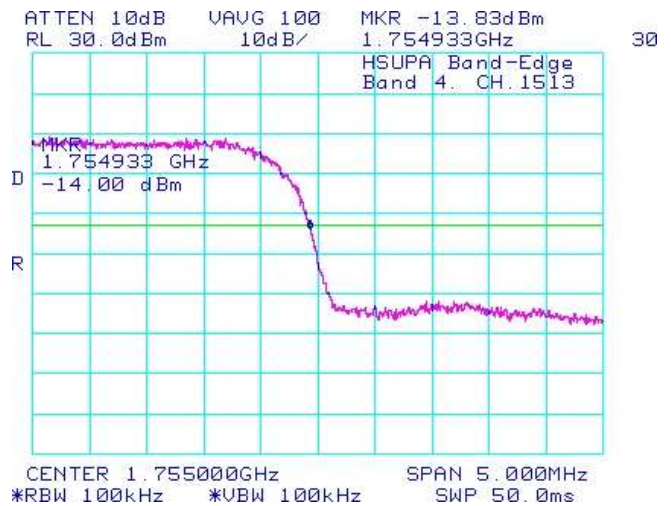


**UMTS Conducted RF Emission Test Data cont'd**

**Figure 1-32b: Band 4 , Low Channel Mask**



**Figure 1-33b: Band 4 , High Channel Mask**



APPENDIX 2A – GSM CONDUCTED RF OUTPUT POWER TEST DATA



**Test Report No.**  
RTS-3933-1105-43B\_Rev1

**Dates of Test**  
Feb 7 to March 22, May 6 to May 31 and June 19, 2011

**FCC ID:** L6ARDU70CW **IC:** 2503A-RDU70CW  
**FCC ID:** L6ARDV70UW **IC:** 2503A-RDV70UW

GSM Conducted RF Output Power Test Data

The following test configurations were measured for model RDU71CW:

The conducted RF output power was measured on the BlackBerry® smartphone using the Communication Tester, Rohde & Schwarz, model CMU 200. The low, middle and high channels were measured at maximum output power. The insertion loss of the coaxial cable from the CMU 200 to the BlackBerry® smartphone was compensated for in the measurements.

Peak nominal output power is 32.5 dBm ±0.5 dB for GSM850 and 30.5 dBm ±0.5 dB for PCS.

Peak nominal output power is 29.5 dBm ±0.5 dB for GSM850 EDGE Mode (2-timeslot uplink) and 29.0 dBm ±0.5 dB for PCS EDGE Mode (2-timeslot uplink).

Date of Test: Feb 7, 2011

The environmental conditions were: Temperature: 23 °C  
Humidity: 30 %

The measurements were performed by Daoud Attayi

Channel	Frequency (MHz)	Maximum Output Power (dBm)	Maximum Output Power (Watts)	Channel	Frequency (MHz)	Maximum Output Power (dBm)	Maximum Output Power (Watts)
<u>GSM850</u>				<u>GSM850 Edge</u>			
128	824.20	32.6	1.82	128	824.20	30.2	1.05
189	837.60	32.8	1.91	189	837.60	30.4	1.10
251	848.80	32.7	1.86	251	848.80	30.0	1.00
<u>PCS</u>				<u>PCS Edge</u>			
512	1850.2	30.4	1.10	512	1850.2	28.9	0.78
661	1880.0	30.2	1.05	661	1880.0	29.0	0.79
810	1909.8	30.2	1.05	810	1909.8	28.8	0.76

## APPENDIX 2B – CDMA CONDUCTED RF OUTPUT POWER TEST DATA






## APPENDIX 2C – UMTS CONDUCTED RF OUTPUT POWER TEST DATA

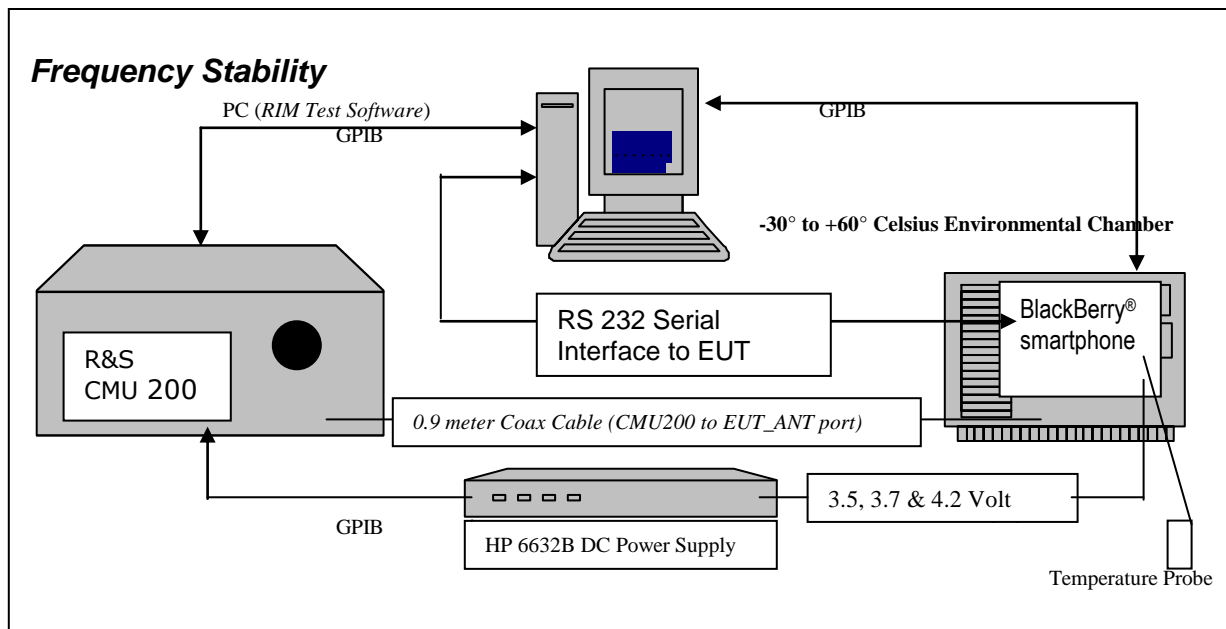


## APPENDIX 3A – GSM FREQUENCY STABILITY TEST DATA

	EMI Test Report for the BlackBerry® smartphone Model RDU71CW, RDV71UW APPENDIX 3A	
<b>Test Report No.</b> RTS-3933-1105-43B_Rev1	<b>Dates of Test</b> Feb 7 to March 22, May 6 to May 31 and June 19, 2011	<b>FCC ID: L6ARDU70CW IC: 2503A-RDU70CW</b> <b>FCC ID: L6ARDV70UW IC: 2503A-RDV70UW</b>

### GSM Frequency Stability Test Data

The following test configurations were measured for model RDU71CW:



The measurements were performed by Maurice Battler.

CFR 47 Chapter 1 - Federal Communications Commission Rules

Part 2 Required Measurements

2.995 Frequency Stability - Procedures

(a,b) Frequency Stability - Temperature Variation


(d) Frequency Stability - Voltage Variation

#### **24.235/22.917** Frequency Stability.

*The frequency stability shall be sufficient to ensure that the fundamental emission stays within the authorized frequency block.*

*The EUT meets the requirements as stated in CFR 47 chapter 1, Section 24.235, CFR 47 chapter 1, Section 22.917 RSS-132, 4.3 Frequency Stability, and RSS-133, 6.3 Frequency Stability.*

Frequency Stability measurement devices were configured as presented in the block diagram recording frequency, power, data, temperatures, and stepped voltages controlled via a GPIB interface linked to the Environmental chamber, a DC power supply, and the Communications Test Set. A 0.9-metre coax cable was calibrated to characterize the insertion loss for the transmitted frequencies between the RF input/output of the CMU 200 and the EUT antenna port.

	EMI Test Report for the BlackBerry® smartphone Model RDU71CW, RDV71UW APPENDIX 3A	
<b>Test Report No.</b> RTS-3933-1105-43B_Rev1	<b>Dates of Test</b> Feb 7 to March 22, May 6 to May 31 and June 19, 2011	<b>FCC ID:</b> L6ARDU70CW <b>IC:</b> 2503A-RDU70CW <b>FCC ID:</b> L6ARDV70UW <b>IC:</b> 2503A-RDV70UW

Calibration for the Cable Loss was performed in the RF Laboratory using the Agilent power meter and Agilent Signal Generator.

**Procedure:**


The EUT was placed in the Temperature chamber and connected to CMU 200 outside as shown in the figure above. Dry air was pumped inside the temperature chamber to maintain a backpressure during the test. The EUT was kept in the off condition at all times except when the measurements were to be made.

The chamber was switched on and the temperature was set to -30°C. After the chamber stabilized at -30 °C there was a soak period of one hour to alleviate moisture in the chamber, the EUT voltage was enabled. The system software recorded the frequency, power, and associated measurements.

A Computer system controlled the automated software. This application was given the command of activating all machines intrinsic to the temperature and voltage tests controlling the CMU 200 via the GPIB Bus. The Environmental Chamber was instructed through an RS-232 serial line. The EUT dialogue was passed through a serial connection.

The EUT repetitively transmitted 100 bursts for each set of programmed parameters recording temperature, voltage settings, and systematically selected frequencies. The power supply was cycled from minimum voltage 3.6 volts, to 3.7 volts to 4.2 volts maximum voltage. The frequency error was measured at a maximum output power and recorded by the automated system test software.

The EUT output power and frequency was measured at 3.6 volts, 3.7 volts and 4.2 volts. The transmit frequency was varied in 3 steps consisting of 824.2, 836.4, and 848.8 MHz for the GSM850 band, 1850.2, 1880.0 and 1909.8 MHz for the PCS1900 band. This frequency was recorded in MHz and deviation from nominal, in Parts Per Million. After the initial one-hour soak at the beginning of the tests, a period of thirty minutes soak was initialized between each ascending temperature step, before proceeding to the next measurement test cycle.

	EMI Test Report for the BlackBerry® smartphone Model RDU71CW, RDV71UW APPENDIX 3A	
<b>Test Report No.</b> RTS-3933-1105-43B_Rev1	<b>Dates of Test</b> Feb 7 to March 22, May 6 to May 31 and June 19, 2011	<b>FCC ID:</b> L6ARDU70CW <b>IC:</b> 2503A-RDU70CW <b>FCC ID:</b> L6ARDV70UW <b>IC:</b> 2503A-RDV70UW

PROCEDURE:

The test system software for commencing the Frequency Stability Tests carried through the following cycle.

1. Switch on the HP 6632B power supply; CMU 200 Communications test Set, and Environmental Chamber.
2. Start test program
3. Set the Temperature to  $-30^{\circ}\text{C}$  and maintain a period of one- hour soak time, with the EUT supply voltage disabled.
4. Set power supply voltage to 3.6 volts.
5. Set up CMU 200 Radio Communication Tester.
6. Command the CMU 200 to switch to the low channel.
7. Enable the voltage to the EUT, and connect a link to the CMU 200 test set.
8. EUT is commanded to Transmit 100 Bursts.
9. Software logs the following data from the CMU 200, power supply and temperature chamber: Traffic Channel Number, Traffic Channel Frequency, Power Level, Chamber Temperature, Supply Voltage, Power and Frequency Error.
10. The CMU 200 commands the EUT to change frequency to the middle channel and high channel and repeats steps 7 to 9.
11. Repeat steps 5 to 10 changing the supply voltage to 3.7 Volts
12. Increase temperature by  $10^{\circ}\text{C}$  and soak for 1/2 hour.
13. Repeat steps 4 - 12 for temperatures  $-30^{\circ}\text{C}$  to  $60^{\circ}\text{C}$ .
14. Repeat steps 5 to 10 changing the supply voltage to 4.2 volts

Procedure 5 to 10 was repeated at room temperature ( $20^{\circ}\text{C}$ ) with the power supply voltage set to 3.6, 3.7 and 4.2 volts.

The maximum frequency error in the GSM850 band measured was **0.0277 PPM**.  
The maximum frequency error in the PCS1900 band measured was **0.0319 PPM**.



**Test Report No.**  
RTS-3933-1105-43B\_Rev1

**Dates of Test**  
Feb 7 to March 22, May 6 to May 31 and  
June 19, 2011

**FCC ID:** L6ARDU70CW **IC:** 2503A-RDU70CW  
**FCC ID:** L6ARDV70UW **IC:** 2503A-RDV70UW

GSM850 Channel results: channels 128, 189 and 251 @ 20°C maximum transmitted power

Traffic Channel Number	GSM850 Frequency (MHz)	Voltage (Volts)	Temperature (Celsius)	Frequency Error (Hz)	PPM
128	824.2	3.6	20	5	0.0056
189	836.4	3.6	20	6	0.0072
251	848.8	3.6	20	7	0.0081

Traffic Channel Number	GSM850 Frequency (MHz)	Voltage (Volts)	Temperature (Celsius)	Frequency Error (Hz)	PPM
128	824.2	3.7	20	8	0.0094
189	836.4	3.7	20	-4	-0.0049
251	848.8	3.7	20	7	0.0078

Traffic Channel Number	GSM850 Frequency (MHz)	Voltage (Volts)	Temperature (Celsius)	Frequency Error (Hz)	PPM
128	824.2	4.2	20	-4	-0.0049
189	836.4	4.2	20	-5	-0.0059
251	848.8	4.2	20	-5	-0.0064

**Test Report No.**  
RTS-3933-1105-43B\_Rev1

**Dates of Test**  
Feb 7 to March 22, May 6 to May 31 and  
June 19, 2011

**FCC ID:** L6ARDU70CW **IC:** 2503A-RDU70CW  
**FCC ID:** L6ARDV70UW **IC:** 2503A-RDV70UW

GSM850 Results: channel 128 @ maximum transmitted power

Traffic Channel Number	Frequency (MHz)	Voltage (Volts)	Temperature (Celsius)	Frequency Error (Hz)	PPM
128	824.2	3.6	-30	-12	-0.0148
128	824.2	3.6	-20	6	0.0074
128	824.2	3.6	-10	15	0.0177
128	824.2	3.6	0	23	<b>0.0277</b>
128	824.2	3.6	10	15	0.0179
128	824.2	3.6	20	5	0.0056
128	824.2	3.6	30	6	0.0071
128	824.2	3.6	40	-12	-0.0150
128	824.2	3.6	50	-4	-0.0049
128	824.2	3.6	60	-7	-0.0088

Traffic Channel Number	Frequency (MHz)	Voltage (Volts)	Temperature (Celsius)	Frequency Error (Hz)	PPM
128	824.2	3.7	-30	-8	-0.0093
128	824.2	3.7	-20	-5	-0.0064
128	824.2	3.7	-10	13	0.0154
128	824.2	3.7	0	14	0.0169
128	824.2	3.7	10	11	0.0132
128	824.2	3.7	20	8	0.0094
128	824.2	3.7	30	5	0.0066
128	824.2	3.7	40	-5	-0.0060
128	824.2	3.7	50	-7	-0.0091
128	824.2	3.7	60	-12	-0.0151

Traffic Channel Number	Frequency (MHz)	Voltage (Volts)	Temperature (Celsius)	Frequency Error (Hz)	PPM
128	824.2	4.2	-30	6	0.0068
128	824.2	4.2	-20	7	0.0084
128	824.2	4.2	-10	8	0.0101
128	824.2	4.2	0	14	0.0165
128	824.2	4.2	10	14	0.0165
128	824.2	4.2	20	-4	-0.0049
128	824.2	4.2	30	-8	-0.0092
128	824.2	4.2	40	-11	-0.0139
128	824.2	4.2	50	4	0.0049
128	824.2	4.2	60	-3	-0.0035





**Test Report No.**  
RTS-3933-1105-43B\_Rev1

**Dates of Test**  
Feb 7 to March 22, May 6 to May 31 and  
June 19, 2011

**FCC ID:** L6ARDU70CW **IC:** 2503A-RDU70CW  
**FCC ID:** L6ARDV70UW **IC:** 2503A-RDV70UW

GSM850 Results: channel 189 @ maximum transmitted power

Traffic Channel Number	Frequency (MHz)	Voltage (Volts)	Temperature (Celsius)	Frequency Error (Hz)	PPM
189	836.4	3.6	-30	-13	-0.0161
189	836.4	3.6	-20	-5	-0.0063
189	836.4	3.6	-10	12	0.0149
189	836.4	3.6	0	12	0.0143
189	836.4	3.6	10	20	0.0239
189	836.4	3.6	20	6	0.0072
189	836.4	3.6	30	-6	-0.0076
189	836.4	3.6	40	4	0.0053
189	836.4	3.6	50	-6	-0.0073
189	836.4	3.6	60	-11	-0.0134

Traffic Channel Number	Frequency (MHz)	Voltage (Volts)	Temperature (Celsius)	Frequency Error (Hz)	PPM
189	836.4	3.7	-30	-11	-0.0132
189	836.4	3.7	-20	-6	-0.0073
189	836.4	3.7	-10	12	0.0139
189	836.4	3.7	0	20	0.0242
189	836.4	3.7	10	12	0.0148
189	836.4	3.7	20	-4	-0.0049
189	836.4	3.7	30	-5	-0.0059
189	836.4	3.7	40	-10	-0.0118
189	836.4	3.7	50	5	0.0055
189	836.4	3.7	60	-8	-0.0096

Traffic Channel Number	Frequency (MHz)	Voltage (Volts)	Temperature (Celsius)	Frequency Error (Hz)	PPM
189	836.4	4.2	-30	17	0.0201
189	836.4	4.2	-20	13	0.0153
189	836.4	4.2	-10	6	0.0073
189	836.4	4.2	0	16	0.0197
189	836.4	4.2	10	16	0.0192
189	836.4	4.2	20	-5	-0.0059
189	836.4	4.2	30	-9	-0.0102
189	836.4	4.2	40	-7	-0.0082
189	836.4	4.2	50	-4	-0.0052
189	836.4	4.2	60	-5	-0.0059

This report shall NOT be reproduced except in full without the written consent of RIM Testing Services  
- A division of Research in Motion Limited.

**Test Report No.**  
RTS-3933-1105-43B\_Rev1

**Dates of Test**  
Feb 7 to March 22, May 6 to May 31 and  
June 19, 2011

**FCC ID:** L6ARDU70CW **IC:** 2503A-RDU70CW  
**FCC ID:** L6ARDV70UW **IC:** 2503A-RDV70UW

GSM850 Results: channel 251 @ maximum transmitted power

Traffic Channel Number	Frequency (MHz)	Voltage (Volts)	Temperature (Celsius)	Frequency Error (Hz)	PPM
251	848.8	3.6	-30	-9	-0.0110
251	848.8	3.6	-20	-4	-0.0047
251	848.8	3.6	-10	8	0.0095
251	848.8	3.6	0	16	0.0193
251	848.8	3.6	10	22	0.0253
251	848.8	3.6	20	7	0.0081
251	848.8	3.6	30	-3	-0.0035
251	848.8	3.6	40	-7	-0.0078
251	848.8	3.6	50	-8	-0.0094
251	848.8	3.6	60	-9	-0.0102

Traffic Channel Number	Frequency (MHz)	Voltage (Volts)	Temperature (Celsius)	Frequency Error (Hz)	PPM
251	848.8	3.7	-30	-11	-0.0135
251	848.8	3.7	-20	-9	-0.0110
251	848.8	3.7	-10	14	0.0169
251	848.8	3.7	0	18	0.0208
251	848.8	3.7	10	8	0.0100
251	848.8	3.7	20	7	0.0078
251	848.8	3.7	30	3	0.0032
251	848.8	3.7	40	-7	-0.0086
251	848.8	3.7	50	-3	-0.0031
251	848.8	3.7	60	-5	-0.0057

Traffic Channel Number	Frequency (MHz)	Voltage (Volts)	Temperature (Celsius)	Frequency Error (Hz)	PPM
251	848.8	4.2	-30	12	0.0141
251	848.8	4.2	-20	8	0.0094
251	848.8	4.2	-10	17	0.0199
251	848.8	4.2	0	21	0.0250
251	848.8	4.2	10	12	0.0146
251	848.8	4.2	20	-5	-0.0064
251	848.8	4.2	30	-7	-0.0078
251	848.8	4.2	40	-8	-0.0090
251	848.8	4.2	50	6	0.0067
251	848.8	4.2	60	4	0.0049



**Test Report No.**  
RTS-3933-1105-43B\_Rev1

**Dates of Test**  
Feb 7 to March 22, May 6 to May 31 and  
June 19, 2011

**FCC ID:** L6ARDU70CW **IC:** 2503A-RDU70CW  
**FCC ID:** L6ARDV70UW **IC:** 2503A-RDV70UW

PCS Channel results: channels 512, 661, & 810 @ 20°C maximum transmitted power

Traffic Channel Number	PCS Frequency (MHz)	Voltage (Volts)	Temperature (Celsius)	Frequency Error (Hz)	PPM
512	1850.20	3.6	20	25.00	0.0135
661	1880.00	3.6	20	28.00	0.0149
810	1909.80	3.6	20	25.00	0.0131

Traffic Channel Number	PCS Frequency (MHz)	Voltage (Volts)	Temperature (Celsius)	Frequency Error (Hz)	PPM
512	1850.20	3.7	20	24.00	0.0130
661	1880.00	3.7	20	21.00	0.0112
810	1909.80	3.7	20	23.00	0.0120

Traffic Channel Number	PCS Frequency (MHz)	Voltage (Volts)	Temperature (Celsius)	Frequency Error (Hz)	PPM
512	1850.20	4.2	20	17.00	0.0092
661	1880.00	4.2	20	25.00	0.0133
810	1909.80	4.2	20	19.00	0.0099

**Test Report No.**  
RTS-3933-1105-43B\_Rev1

**Dates of Test**  
Feb 7 to March 22, May 6 to May 31 and  
June 19, 2011

**FCC ID:** L6ARDU70CW **IC:** 2503A-RDU70CW  
**FCC ID:** L6ARDV70UW **IC:** 2503A-RDV70UW

PCS1900 Results: channel 512 @ maximum transmitted power

Traffic Channel Number	Frequency (MHz)	Voltage (Volts)	Temperature (Celsius)	Frequency Error (Hz)	PPM
512	1850.2	3.6	-30	45.00	0.0243
512	1850.2	3.6	-20	26.00	0.0141
512	1850.2	3.6	-10	44.00	0.0238
512	1850.2	3.6	0	58.00	0.0313
512	1850.2	3.6	10	42.00	0.0227
512	1850.2	3.6	20	25.00	0.0135
512	1850.2	3.6	30	16.00	0.0086
512	1850.2	3.6	40	13.00	0.0070
512	1850.2	3.6	50	11.00	0.0059
512	1850.2	3.6	60	10.00	0.0054

Traffic Channel Number	Frequency (MHz)	Voltage (Volts)	Temperature (Celsius)	Frequency Error (Hz)	PPM
512	1850.2	3.7	-30	28.00	0.0151
512	1850.2	3.7	-20	27.00	0.0146
512	1850.2	3.7	-10	40.00	0.0216
512	1850.2	3.7	0	59.00	<b>0.0319</b>
512	1850.2	3.7	10	55.00	0.0297
512	1850.2	3.7	20	24.00	0.0130
512	1850.2	3.7	30	13.00	0.0070
512	1850.2	3.7	40	14.00	0.0076
512	1850.2	3.7	50	9.00	0.0049
512	1850.2	3.7	60	7.00	0.0038

Traffic Channel Number	Frequency (MHz)	Voltage (Volts)	Temperature (Celsius)	Frequency Error (Hz)	PPM
512	1850.2	4.2	-30	31.00	0.0168
512	1850.2	4.2	-20	28.00	0.0151
512	1850.2	4.2	-10	48.00	0.0259
512	1850.2	4.2	0	57.00	0.0308
512	1850.2	4.2	10	42.00	0.0227
512	1850.2	4.2	20	17.00	0.0092
512	1850.2	4.2	30	-13.00	-0.0070
512	1850.2	4.2	40	-16.00	-0.0086
512	1850.2	4.2	50	-10.00	-0.0054
512	1850.2	4.2	60	-12.00	-0.0065



**Test Report No.**  
RTS-3933-1105-43B\_Rev1

**Dates of Test**  
Feb 7 to March 22, May 6 to May 31 and  
June 19, 2011

**FCC ID:** L6ARDU70CW **IC:** 2503A-RDU70CW  
**FCC ID:** L6ARDV70UW **IC:** 2503A-RDV70UW

PCS1900 Results: channel 661 @ maximum transmitted power

Traffic Channel Number	Frequency (MHz)	Voltage (Volts)	Temperature (Celsius)	Frequency Error (Hz)	PPM
661	1880.0	3.6	-30	32.00	0.0170
661	1880.0	3.6	-20	30.00	0.0160
661	1880.0	3.6	-10	40.00	0.0213
661	1880.0	3.6	0	57.00	0.0303
661	1880.0	3.6	10	46.00	0.0245
661	1880.0	3.6	20	28.00	0.0149
661	1880.0	3.6	30	15.00	0.0080
661	1880.0	3.6	40	11.00	0.0059
661	1880.0	3.6	50	10.00	0.0053
661	1880.0	3.6	60	7.00	0.0037

Traffic Channel Number	Frequency (MHz)	Voltage (Volts)	Temperature (Celsius)	Frequency Error (Hz)	PPM
661	1880.0	3.7	-30	27.00	0.0144
661	1880.0	3.7	-20	26.00	0.0138
661	1880.0	3.7	-10	40.00	0.0213
661	1880.0	3.7	0	55.00	0.0293
661	1880.0	3.7	10	52.00	0.0277
661	1880.0	3.7	20	21.00	0.0112
661	1880.0	3.7	30	17.00	0.0090
661	1880.0	3.7	40	11.00	0.0059
661	1880.0	3.7	50	15.00	0.0080
661	1880.0	3.7	60	9.00	0.0048

Traffic Channel Number	Frequency (MHz)	Voltage (Volts)	Temperature (Celsius)	Frequency Error (Hz)	PPM
661	1880.0	4.2	-30	28.00	0.0149
661	1880.0	4.2	-20	36.00	0.0191
661	1880.0	4.2	-10	41.00	0.0218
661	1880.0	4.2	0	58.00	0.0309
661	1880.0	4.2	10	46.00	0.0245
661	1880.0	4.2	20	25.00	0.0133
661	1880.0	4.2	30	14.00	0.0074
661	1880.0	4.2	40	-16.00	-0.0085
661	1880.0	4.2	50	-9.00	-0.0048
661	1880.0	4.2	60	-11.00	-0.0059

This report shall NOT be reproduced except in full without the written consent of RIM Testing Services  
- A division of Research in Motion Limited.



**Test Report No.**  
RTS-3933-1105-43B\_Rev1

**Dates of Test**  
Feb 7 to March 22, May 6 to May 31 and  
June 19, 2011

**FCC ID:** L6ARDU70CW **IC:** 2503A-RDU70CW  
**FCC ID:** L6ARDV70UW **IC:** 2503A-RDV70UW

PCS1900 Results: channel 810 @ maximum transmitted power


Traffic Channel Number	Frequency (MHz)	Voltage (Volts)	Temperature (Celsius)	Frequency Error (Hz)	20BPPM
810	1909.8	3.6	-30	29.00	0.0152
810	1909.8	3.6	-20	22.00	0.0115
810	1909.8	3.6	-10	41.00	0.0215
810	1909.8	3.6	0	61.00	<b>0.0319</b>
810	1909.8	3.6	10	51.00	0.0267
810	1909.8	3.6	20	25.00	0.0131
810	1909.8	3.6	30	16.00	0.0084
810	1909.8	3.6	40	14.00	0.0073
810	1909.8	3.6	50	11.00	0.0058
810	1909.8	3.6	60	7.00	0.0037

Traffic Channel Number	Frequency (MHz)	Voltage (Volts)	Temperature (Celsius)	Frequency Error (Hz)	PPM
810	1909.8	3.7	-30	28.00	0.0147
810	1909.8	3.7	-20	32.00	0.0168
810	1909.8	3.7	-10	44.00	0.0230
810	1909.8	3.7	0	55.00	0.0288
810	1909.8	3.7	10	52.00	0.0272
810	1909.8	3.7	20	23.00	0.0120
810	1909.8	3.7	30	12.00	0.0063
810	1909.8	3.7	40	11.00	0.0058
810	1909.8	3.7	50	12.00	0.0063
810	1909.8	3.7	60	-9.00	-0.0047

Traffic Channel Number	Frequency (MHz)	Voltage (Volts)	Temperature (Celsius)	Frequency Error (Hz)	PPM
810	1909.8	4.2	-30	26.00	0.0136
810	1909.8	4.2	-20	31.00	0.0162
810	1909.8	4.2	-10	39.00	0.0204
810	1909.8	4.2	0	50.00	0.0262
810	1909.8	4.2	10	44.00	0.0230
810	1909.8	4.2	20	19.00	0.0099
810	1909.8	4.2	30	8.00	0.0042
810	1909.8	4.2	40	-19.00	-0.0099
810	1909.8	4.2	50	-9.00	-0.0047
810	1909.8	4.2	60	-13.00	-0.0068

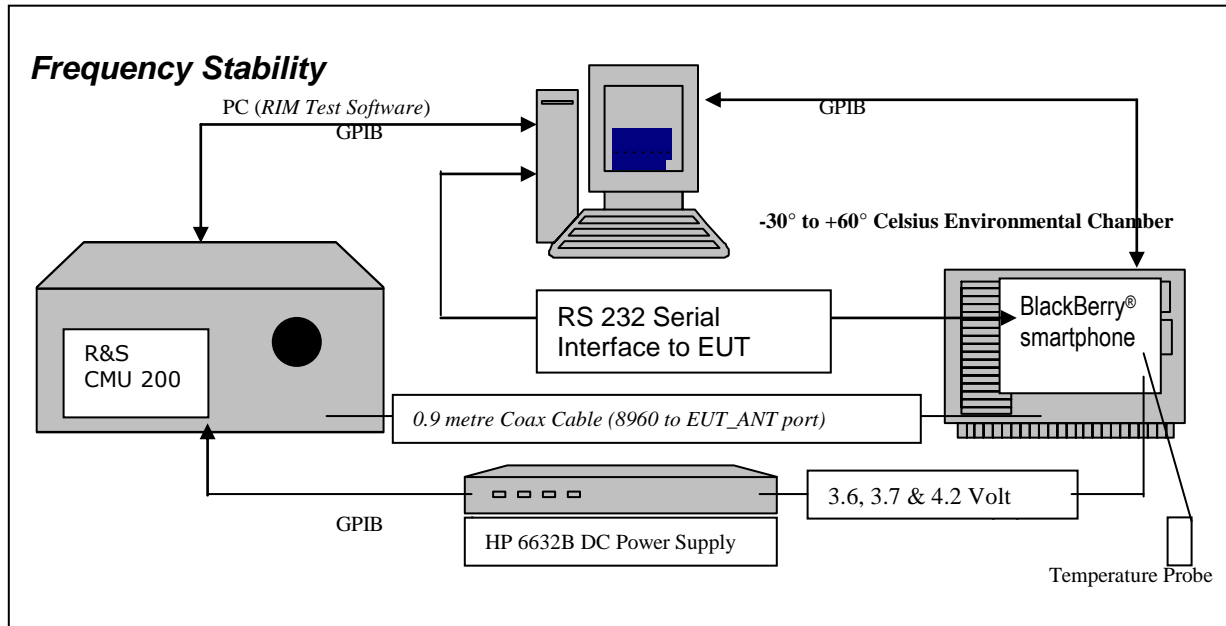
This report shall NOT be reproduced except in full without the written consent of RIM Testing Services  
- A division of Research in Motion Limited.

## APPENDIX 3B – CDMA FREQUENCY STABILITY TEST DATA

	EMI Test Report for the BlackBerry® smartphone Model RDU71CW, RDV71UW APPENDIX 3B	
<b>Test Report No.</b> RTS-3933-1105-43B_Rev1	<b>Dates of Test</b> Feb 7 to March 22, May 6 to May 31 and June 19, 2011	<b>FCC ID:</b> L6ARDU70CW <b>IC:</b> 2503A-RDU70CW <b>FCC ID:</b> L6ARDV70UW <b>IC:</b> 2503A-RDV70UW

### CDMA Frequency Stability Test Data

The following test configurations were measured for model RDU71CW:



#### CFR 47 Chapter 1 - Federal Communications Commission Rules

##### Part 2 Required Measurements

##### **2.1055** Frequency Stability - Procedures

(a,b) Frequency Stability - Temperature Variation

(d) Frequency Stability - Voltage Variation

##### *22.917/24.235 Frequency Stability.*

*The frequency stability shall be sufficient to ensure that the fundamental emission stays within the authorized frequency block.*

The RDU71CW BlackBerry® smartphone, (referred as EUT herein and after) transmitted frequencies are less than 0.1 ppm of the received frequency from the Agilent 8960 CDMA Base Station Simulator

*The EUT meets the requirements as stated in CFR 47 chapter 1, Section 24.235, RSS-133, CFR 47 chapter 1, Section 22.917 and RSS-132 Frequency Stability.*

Frequency Stability measurement devices were configured as presented in the block diagram recording frequency, power, data, temperatures, and stepped voltages controlled via a GPIB interface linked to the Environmental chamber, a DC power supply, and the Communications Test Set. A 0.9-metre coax cable was calibrated to characterize the insertion loss for the transmitted frequencies between the RF input/output of the base station simulator and the EUT antenna port; located inside the environmental chamber.



**Test Report No.**  
RTS-3933-1105-43B\_Rev1

**Dates of Test**  
Feb 7 to March 22, May 6 to May 31 and  
June 19, 2011

**FCC ID:** L6ARDU70CW **IC:** 2503A-RDU70CW  
**FCC ID:** L6ARDV70UW **IC:** 2503A-RDV70UW

Calibration for the Cable Loss was performed in the RF Laboratory using the Giga-tronics power metre and Agilent Signal Generator. The cable assembly from the RF input to the RF output was measured at the following Frequencies:

PCS Frequency (MHz)	Cable loss (dB)
1851.20	1.10
1880.00	1.10
1908.75	1.10

Cellular Frequency (MHz)	Cable loss (dB)
824.70	0.50
836.52	0.50
848.31	0.50

**Procedure:**

The EUT was placed in the Temperature chamber and connected to the Agilent 8960 outside as shown in the figure above. Dry air was pumped inside the temperature chamber to maintain a backpressure during the test. The EUT was kept in the off condition at all times except when the measurements were to be made.

The chamber was switched on and the temperature was set to -30°C. After the chamber stabilized at -30 °C there was a soak period of one hour to alleviate moisture in the chamber, the EUT voltage was enabled. The system software recorded the frequency, power, and associated measurements.

A Computer system controlled the automated software. This application was given the command of activating all machines intrinsic to the temperature and voltage tests controlling the base station simulator via the GPIB Bus. The Environmental Chamber was instructed through an RS-232 serial line. The EUT dialogue was passed through a serial connection.

The EUT repetitively transmitted 100 bursts for each set of programmed parameters recording temperature, voltage settings, and systematically selected frequencies. The power supply was cycled from minimum voltage 3.6 volts, to 3.7 volts nominal voltage to 4.2 volts maximum voltage. The frequency error was measured at a maximum output power and recorded by the automated system test software.

The EUT output power and frequency was measured at 3.6 volts, 3.7 volts and 4.2 volts. The transmit frequency was varied in 3 steps consisting of 824.70, 836.52, and 848.31 MHz for the cellular band and 1851.20, 1880.00 and 1908.75 MHz for the PCS band. This frequency was recorded in MHz and deviation from nominal, in Parts per Million.




**Test Report No.**  
RTS-3933-1105-43B\_Rev1

**Dates of Test**  
Feb 7 to March 22, May 6 to May 31 and  
June 19, 2011

**FCC ID: L6ARDU70CW IC: 2503A-RDU70CW**  
**FCC ID: L6ARDV70UW IC: 2503A-RDV70UW**

After the initial one-hour soak at the beginning of the tests, a period of thirty minutes soak was initialized between each ascending temperature step, before proceeding to the next measurement test cycle.

	EMI Test Report for the BlackBerry® smartphone Model RDU71CW, RDV71UW APPENDIX 3B	
<b>Test Report No.</b> RTS-3933-1105-43B_Rev1	<b>Dates of Test</b> Feb 7 to March 22, May 6 to May 31 and June 19, 2011	<b>FCC ID:</b> L6ARDU70CW <b>IC:</b> 2503A-RDU70CW <b>FCC ID:</b> L6ARDV70UW <b>IC:</b> 2503A-RDV70UW

**PROCEDURE:**

The test system software for commencing the Frequency Stability Tests carried through the following cycle.

1. Switch on the HP 6632B power supply; CMU 200 Communications test Set, and Environmental Chamber.
2. Start test program
3. Set the Temperature to -30°C and maintain a period of one- hour soak time, with the EUT supply voltage disabled.
4. Set power supply voltage to 3.6 volts.
5. Set up CMU 200 Radio Communication Tester.
6. Command the CMU 200 to switch to the low channel.
7. Enable the voltage to the EUT, and connect a link to the CMU 200 test set.
8. EUT is commanded to Transmit 100 Bursts.
9. Software logs the following data from the CMU 200, power supply and temperature chamber: Traffic Channel Number, Traffic Channel Frequency, Power Level, Chamber Temperature, Supply Voltage, Power and Frequency Error.
10. The CMU 200 commands the EUT to change frequency to the middle channel and high channel and repeats steps 7 to 9.
11. Repeat steps 5 to 10 changing the supply voltage to 3.7 Volts
12. Increase temperature by 10°C and soak for 1/2 hour.
13. Repeat steps 4 - 12 for temperatures -30°C to 60°C.
14. Repeat steps 5 to 10 changing the supply voltage to 4.2 volts

Procedure 5 to 10 was repeated at room temperature (20°C) with the power supply voltage set to 3.6, 3.7 and 4.2 volts

The maximum frequency error in the CDMA Cellular band measured was **-0.0717 PPM**.  
The maximum frequency error in the CDMA PCS band measured was **-0.0394 PPM**.



**Test Report No.**  
RTS-3933-1105-43B\_Rev1

**Dates of Test**  
Feb 7 to March 22, May 6 to May 31 and  
June 19, 2011

**FCC ID:** L6ARDU70CW **IC:** 2503A-RDU70CW  
**FCC ID:** L6ARDV70UW **IC:** 2503A-RDV70UW

Cellular Channel results: channels 1013, 384 and 777 @ 20°C maximum transmitted power

Traffic Channel Number	Cellular Frequency (MHz)	Voltage (Volts)	Temperature (Celsius)	Frequency Error (Hz)	PPM
1013	824.700	3.6	20	-21	-0.0255
384	836.520	3.6	20	-36	-0.0430
777	848.310	3.6	20	-14	-0.0165

Traffic Channel Number	Cellular Frequency (MHz)	Voltage (Volts)	Temperature (Celsius)	Frequency Error (Hz)	PPM
1013	824.700	3.7	20	19	0.0230
384	836.520	3.7	20	-22	-0.0263
777	848.310	3.7	20	-47	-0.0554

Traffic Channel Number	Cellular Frequency (MHz)	Voltage (Volts)	Temperature (Celsius)	Frequency Error (Hz)	PPM
1013	824.700	4.2	20	-19	-0.0230
384	836.520	4.2	20	23	0.0275
777	848.310	4.2	20	-32	-0.0377

**Test Report No.**  
RTS-3933-1105-43B\_Rev1

**Dates of Test**  
Feb 7 to March 22, May 6 to May 31 and  
June 19, 2011

**FCC ID:** L6ARDU70CW **IC:** 2503A-RDU70CW  
**FCC ID:** L6ARDV70UW **IC:** 2503A-RDV70UW

Cellular Results: channel 1013 @ maximum transmitted power

Traffic Channel Number	Frequency (MHz)	Voltage (Volts)	Temperature (Celsius)	Frequency Error (Hz)	PPM
1013	824.70	3.6	-30	-18	-0.0218
1013	824.70	3.6	-20	22	0.0267
1013	824.70	3.6	-10	-18	-0.0218
1013	824.70	3.6	0	-23	-0.0424
1013	824.70	3.6	10	23	0.0279
1013	824.70	3.6	20	-21	-0.0255
1013	824.70	3.6	30	24	0.0291
1013	824.70	3.6	40	50	0.0606
1013	824.70	3.6	50	36	0.0437
1013	824.70	3.6	60	-35	-0.0424

Traffic Channel Number	Frequency (MHz)	Voltage (Volts)	Temperature (Celsius)	Frequency Error (Hz)	PPM
1013	824.70	3.7	-30	17	0.0206
1013	824.70	3.7	-20	14	0.0170
1013	824.70	3.7	-10	17	0.0206
1013	824.70	3.7	0	-26	-0.0315
1013	824.70	3.7	10	21	0.0255
1013	824.70	3.7	20	19	0.0230
1013	824.70	3.7	30	-27	-0.0327
1013	824.70	3.7	40	37	0.0449
1013	824.70	3.7	50	51	0.0618
1013	824.70	3.7	60	35	0.0424

Traffic Channel Number	Frequency (MHz)	Voltage (Volts)	Temperature (Celsius)	Frequency Error (Hz)	PPM
1013	824.70	4.2	-30	16	0.0194
1013	824.70	4.2	-20	20	0.0243
1013	824.70	4.2	-10	27	0.0327
1013	824.70	4.2	0	-19	-0.0230
1013	824.70	4.2	10	-30	-0.0364
1013	824.70	4.2	20	-19	-0.0230
1013	824.70	4.2	30	22	0.0267
1013	824.70	4.2	40	-38	-0.0461
1013	824.70	4.2	50	36	0.0437
1013	824.70	4.2	60	50	0.0606



<b>Test Report No.</b> RTS-3933-1105-43B_Rev1	<b>Dates of Test</b> Feb 7 to March 22, May 6 to May 31 and June 19, 2011	<b>FCC ID:</b> L6ARDU70CW <b>IC:</b> 2503A-RDU70CW <b>FCC ID:</b> L6ARDV70UW <b>IC:</b> 2503A-RDV70UW
--	---	--

Cellular Results: channel 384 @ maximum transmitted power

Traffic Channel Number	Frequency (MHz)	Voltage (Volts)	Temperature (Celsius)	Frequency Error (Hz)	PPM
384	836.52	3.6	-30	13	0.0155
384	836.52	3.6	-20	27	0.0323
384	836.52	3.6	-10	13	0.0155
384	836.52	3.6	0	-13	0.0550
384	836.52	3.6	10	-11	-0.0131
384	836.52	3.6	20	-36	-0.0430
384	836.52	3.6	30	18	0.0215
384	836.52	3.6	40	37	0.0442
384	836.52	3.6	50	38	0.0454
384	836.52	3.6	60	46	0.0550

Traffic Channel Number	Frequency (MHz)	Voltage (Volts)	Temperature (Celsius)	Frequency Error (Hz)	PPM
384	836.52	3.7	-30	13	0.0155
384	836.52	3.7	-20	-31	-0.0371
384	836.52	3.7	-10	-16	-0.0191
384	836.52	3.7	0	13	0.0155
384	836.52	3.7	10	-14	-0.0167
384	836.52	3.7	20	-22	-0.0263
384	836.52	3.7	30	24	0.0287
384	836.52	3.7	40	36	0.0430
384	836.52	3.7	50	-30	-0.0359
384	836.52	3.7	60	41	0.0490

Traffic Channel Number	Frequency (MHz)	Voltage (Volts)	Temperature (Celsius)	Frequency Error (Hz)	PPM
384	836.52	4.2	-30	11	0.0131
384	836.52	4.2	-20	-17	-0.0203
384	836.52	4.2	-10	-39	-0.0466
384	836.52	4.2	0	-10	-0.0120
384	836.52	4.2	10	25	0.0299
384	836.52	4.2	20	23	0.0275
384	836.52	4.2	30	22	0.0263
384	836.52	4.2	40	24	0.0287
384	836.52	4.2	50	-60	<b>-0.0717</b>
384	836.52	4.2	60	-58	-0.0693

**Test Report No.**  
RTS-3933-1105-43B\_Rev1

**Dates of Test**  
Feb 7 to March 22, May 6 to May 31 and  
June 19, 2011

**FCC ID:** L6ARDU70CW **IC:** 2503A-RDU70CW  
**FCC ID:** L6ARDV70UW **IC:** 2503A-RDV70UW

Cellular Results: channel 777 @ maximum transmitted power

Traffic Channel Number	Frequency (MHz)	Voltage (Volts)	Temperature (Celsius)	Frequency Error (Hz)	PPM
777	848.31	3.6	-30	-14	-0.0165
777	848.31	3.6	-20	18	0.0212
777	848.31	3.6	-10	-42	-0.0495
777	848.31	3.6	0	-22	-0.0153
777	848.31	3.6	10	49	0.0578
777	848.31	3.6	20	-14	-0.0165
777	848.31	3.6	30	-27	-0.0318
777	848.31	3.6	40	-15	-0.0177
777	848.31	3.6	50	-13	-0.0153
777	848.31	3.6	60	-13	-0.0153

Traffic Channel Number	Frequency (MHz)	Voltage (Volts)	Temperature (Celsius)	Frequency Error (Hz)	PPM
777	848.31	3.7	-30	-12	-0.0141
777	848.31	3.7	-20	-14	-0.0165
777	848.31	3.7	-10	20	0.0236
777	848.31	3.7	0	-36	-0.0424
777	848.31	3.7	10	49	0.0578
777	848.31	3.7	20	-47	-0.0554
777	848.31	3.7	30	-14	-0.0165
777	848.31	3.7	40	14	0.0165
777	848.31	3.7	50	-17	-0.0200
777	848.31	3.7	60	-14	-0.0165

Traffic Channel Number	Frequency (MHz)	Voltage (Volts)	Temperature (Celsius)	Frequency Error (Hz)	PPM
777	848.31	4.2	-30	18	0.0212
777	848.31	4.2	-20	-16	-0.0189
777	848.31	4.2	-10	47	0.0554
777	848.31	4.2	0	31	0.0365
777	848.31	4.2	10	-43	-0.0507
777	848.31	4.2	20	-32	-0.0377
777	848.31	4.2	30	-13	-0.0153
777	848.31	4.2	40	-14	-0.0165
777	848.31	4.2	50	-13	-0.0153
777	848.31	4.2	60	12	0.0141

**Test Report No.**  
RTS-3933-1105-43B\_Rev1

**Dates of Test**  
Feb 7 to March 22, May 6 to May 31 and  
June 19, 2011

**FCC ID:** L6ARDU70CW **IC:** 2503A-RDU70CW  
**FCC ID:** L6ARDV70UW **IC:** 2503A-RDV70UW

PCS Channel results: channels 25, 600, & 1175 @ 20°C maximum transmitted power

Traffic Channel Number	PCS Frequency (MHz)	Voltage (Volts)	Temperature (Celsius)	Frequency Error (Hz)	PPM
25	1851.20	3.6	20	-7	-0.0038
600	1880.00	3.6	20	12	0.0064
1175	1908.75	3.6	20	7	0.0037

Traffic Channel Number	PCS Frequency (MHz)	Voltage (Volts)	Temperature (Celsius)	Frequency Error (Hz)	PPM
25	1851.20	3.7	20	10	0.0054
600	1880.00	3.7	20	11	0.0059
1175	1908.75	3.7	20	8	0.0042

Traffic Channel Number	PCS Frequency (MHz)	Voltage (Volts)	Temperature (Celsius)	Frequency Error (Hz)	PPM
25	1851.20	4.2	20	26	0.0140
600	1880.00	4.2	20	41	0.0218
1175	1908.75	4.2	20	8	0.0042





<b>Test Report No.</b> RTS-3933-1105-43B_Rev1	<b>Dates of Test</b> Feb 7 to March 22, May 6 to May 31 and June 19, 2011	<b>FCC ID:</b> L6ARDU70CW <b>IC:</b> 2503A-RDU70CW <b>FCC ID:</b> L6ARDV70UW <b>IC:</b> 2503A-RDV70UW
--	---	--

PCS Results: channel 9262 @ maximum transmitted power

Traffic Channel Number	Frequency (MHz)	Voltage (Volts)	Temperature (Celsius)	Frequency Error (Hz)	PPM
25	1851.20	3.6	-30	7	0.0038
25	1851.20	3.6	-20	16	0.0086
25	1851.20	3.6	-10	28	0.0151
25	1851.20	3.6	0	-8	0.0054
25	1851.20	3.6	10	-67	-0.0362
25	1851.20	3.6	20	-7	-0.0038
25	1851.20	3.6	30	11	0.0059
25	1851.20	3.6	40	10	0.0054
25	1851.20	3.6	50	16	0.0086
25	1851.20	3.6	60	10	0.0054

Traffic Channel Number	Frequency (MHz)	Voltage (Volts)	Temperature (Celsius)	Frequency Error (Hz)	PPM
25	1851.20	3.7	-30	10	0.0054
25	1851.20	3.7	-20	-9	-0.0049
25	1851.20	3.7	-10	-10	-0.0054
25	1851.20	3.7	0	25	0.0135
25	1851.20	3.7	10	28	0.0151
25	1851.20	3.7	20	10	0.0054
25	1851.20	3.7	30	11	0.0059
25	1851.20	3.7	40	30	0.0162
25	1851.20	3.7	50	39	0.0211
25	1851.20	3.7	60	13	0.0070

Traffic Channel Number	Frequency (MHz)	Voltage (Volts)	Temperature (Celsius)	Frequency Error (Hz)	PPM
25	1851.20	4.2	-30	15	0.0081
25	1851.20	4.2	-20	25	0.0135
25	1851.20	4.2	-10	27	0.0146
25	1851.20	4.2	0	-11	-0.0059
25	1851.20	4.2	10	-11	-0.0059
25	1851.20	4.2	20	26	0.0140
25	1851.20	4.2	30	15	0.0081
25	1851.20	4.2	40	14	0.0076
25	1851.20	4.2	50	9	0.0049
25	1851.20	4.2	60	10	0.0054



<b>Test Report No.</b> RTS-3933-1105-43B_Rev1	<b>Dates of Test</b> Feb 7 to March 22, May 6 to May 31 and June 19, 2011	<b>FCC ID:</b> L6ARDU70CW <b>IC:</b> 2503A-RDU70CW <b>FCC ID:</b> L6ARDV70UW <b>IC:</b> 2503A-RDV70UW
--	---	--

PCS Results: channel 9400 @ maximum transmitted power

Traffic Channel Number	Frequency (MHz)	Voltage (Volts)	Temperature (Celsius)	Frequency Error (Hz)	PPM
600	1880.00	3.6	-30	-20	-0.0106
600	1880.00	3.6	-20	40	0.0213
600	1880.00	3.6	-10	14	0.0074
600	1880.00	3.6	0	10	0.0048
600	1880.00	3.6	10	12	0.0064
600	1880.00	3.6	20	12	0.0064
600	1880.00	3.6	30	28	0.0149
600	1880.00	3.6	40	15	0.0080
600	1880.00	3.6	50	-8	-0.0043
600	1880.00	3.6	60	9	0.0048

Traffic Channel Number	Frequency (MHz)	Voltage (Volts)	Temperature (Celsius)	Frequency Error (Hz)	PPM
600	1880.00	3.7	-30	-74	<b>-0.0394</b>
600	1880.00	3.7	-20	14	0.0074
600	1880.00	3.7	-10	34	0.0181
600	1880.00	3.7	0	41	0.0218
600	1880.00	3.7	10	-51	-0.0271
600	1880.00	3.7	20	11	0.0059
600	1880.00	3.7	30	-6	-0.0032
600	1880.00	3.7	40	-6	-0.0032
600	1880.00	3.7	50	-63	-0.0335
600	1880.00	3.7	60	31	0.0165

Traffic Channel Number	Frequency (MHz)	Voltage (Volts)	Temperature (Celsius)	Frequency Error (Hz)	PPM
600	1880.00	4.2	-30	-73	-0.0388
600	1880.00	4.2	-20	13	0.0069
600	1880.00	4.2	-10	9	0.0048
600	1880.00	4.2	0	10	0.0053
600	1880.00	4.2	10	8	0.0043
600	1880.00	4.2	20	41	0.0218
600	1880.00	4.2	30	-7	-0.0037
600	1880.00	4.2	40	-7	-0.0037
600	1880.00	4.2	50	-7	-0.0037
600	1880.00	4.2	60	-9	-0.0048



**Test Report No.**  
RTS-3933-1105-43B\_Rev1

**Dates of Test**  
Feb 7 to March 22, May 6 to May 31 and  
June 19, 2011

**FCC ID:** L6ARDU70CW **IC:** 2503A-RDU70CW  
**FCC ID:** L6ARDV70UW **IC:** 2503A-RDV70UW


PCS Results: channel 9538 @ maximum transmitted power

Traffic Channel Number	Frequency (MHz)	Voltage (Volts)	Temperature (Celsius)	Frequency Error (Hz)	PPM
1175	1908.75	3.6	-30	12	0.0063
1175	1908.75	3.6	-20	12	0.0063
1175	1908.75	3.6	-10	16	0.0084
1175	1908.75	3.6	0	13	-0.0094
1175	1908.75	3.6	10	13	0.0068
1175	1908.75	3.6	20	7	0.0037
1175	1908.75	3.6	30	-12	-0.0063
1175	1908.75	3.6	40	-12	-0.0063
1175	1908.75	3.6	50	-15	-0.0079
1175	1908.75	3.6	60	-18	-0.0094

Traffic Channel Number	Frequency (MHz)	Voltage (Volts)	Temperature (Celsius)	Frequency Error (Hz)	PPM
1175	1908.75	3.7	-30	-8	-0.0042
1175	1908.75	3.7	-20	12	0.0063
1175	1908.75	3.7	-10	11	0.0058
1175	1908.75	3.7	0	10	0.0052
1175	1908.75	3.7	10	11	0.0058
1175	1908.75	3.7	20	8	0.0042
1175	1908.75	3.7	30	-13	-0.0068
1175	1908.75	3.7	40	-15	-0.0079
1175	1908.75	3.7	50	-18	-0.0094
1175	1908.75	3.7	60	26	0.0136

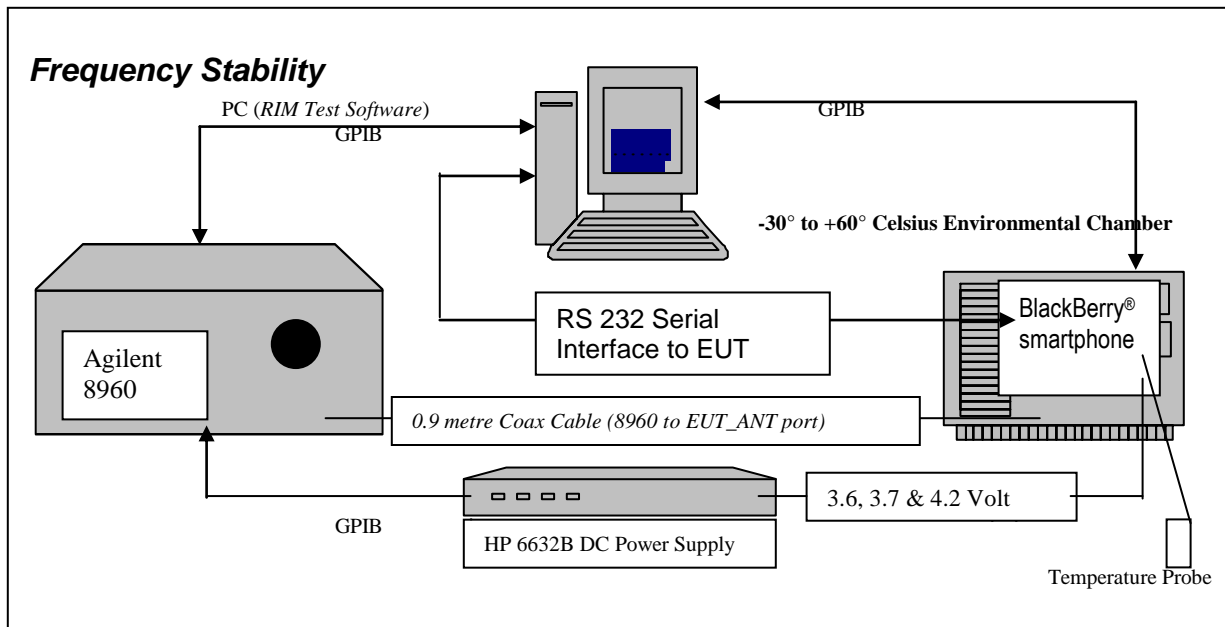
Traffic Channel Number	Frequency (MHz)	Voltage (Volts)	Temperature (Celsius)	Frequency Error (Hz)	PPM
1175	1908.75	4.2	-30	9	0.0047
1175	1908.75	4.2	-20	10	0.0052
1175	1908.75	4.2	-10	12	0.0063
1175	1908.75	4.2	0	43	0.0225
1175	1908.75	4.2	10	-39	-0.0204
1175	1908.75	4.2	20	8	0.0042
1175	1908.75	4.2	30	-14	-0.0073
1175	1908.75	4.2	40	-62	-0.0325
1175	1908.75	4.2	50	-20	-0.0105
1175	1908.75	4.2	60	-15	-0.0079

## APPENDIX 3C – UMTS FREQUENCY STABILITY TEST DATA

	EMI Test Report for the BlackBerry® smartphone Model RDU71CW, RDV71UW APPENDIX 3C	
<b>Test Report No.</b> RTS-3933-1105-43B_Rev1	<b>Dates of Test</b> Feb 7 to March 22, May 6 to May 31 and June 19, 2011	<b>FCC ID:</b> L6ARDU70CW <b>IC:</b> 2503A-RDU70CW <b>FCC ID:</b> L6ARDV70UW <b>IC:</b> 2503A-RDV70UW

### UMTS Frequency Stability Test Data

The following test configurations were measured for model RDV71UW:



The following measurements were performed by Maurice Battler.

CFR 47 Chapter 1 - Federal Communications Commission Rules

Part 2 Required Measurements

**2.1055** Frequency Stability - Procedures

(a,b) Frequency Stability - Temperature Variation


(d) Frequency Stability - Voltage Variation

**24.235** *Frequency Stability.*

*The frequency stability shall be sufficient to ensure that the fundamental emission stays within the authorized frequency block.*

*The EUT meets the requirements as stated in CFR 47 chapter 1, Section 27.54, CFR 47 and RSS-139, 6.3 Frequency Stability.*

Frequency Stability measurement devices were configured as presented in the block diagram recording frequency, power, data, temperatures, and stepped voltages controlled via a GPIB interface linked to the Environmental chamber, a DC power supply, and the Communications Test Set. A 0.9-metre coax cable was calibrated to characterize the insertion loss for the transmitted frequencies between the RF input/output of the CMU 200 and the EUT antenna port.

	EMI Test Report for the BlackBerry® smartphone Model RDU71CW, RDV71UW APPENDIX 3C	
<b>Test Report No.</b> RTS-3933-1105-43B_Rev1	<b>Dates of Test</b> Feb 7 to March 22, May 6 to May 31 and June 19, 2011	<b>FCC ID:</b> L6ARDU70CW <b>IC:</b> 2503A-RDU70CW <b>FCC ID:</b> L6ARDV70UW <b>IC:</b> 2503A-RDV70UW

**Procedure:**


The EUT was placed in the Temperature chamber and connected to CMU 200 outside as shown in the figure above. Dry air was pumped inside the temperature chamber to maintain a backpressure during the test. The EUT was kept in the off condition at all times except when the following measurements were to be made.

The chamber was switched on and the temperature was set to -30°C. After the chamber stabilized at -30 °C there was a soak period of one hour to alleviate moisture in the chamber, the EUT voltage was enabled. The system software recorded the frequency, power, and associated measurements.

A Computer system controlled the automated software. This application was given the command of activating all machines intrinsic to the temperature and voltage tests controlling the CMU 200 via the GPIB Bus. The Environmental Chamber was instructed through an RS-232 serial line. The EUT dialogue was passed through a serial connection.

The EUT repetitively transmitted 100 bursts for each set of programmed parameters recording temperature, voltage settings, and systematically selected frequencies. The power supply was cycled from minimum voltage 3.6 volts, to 3.7 volts to 4.2 volts maximum voltage. The frequency error was measured at a maximum output power and recorded by the automated system test software.

The EUT output power and frequency was measured at 3.6 volts, 3.7 volts and 4.2 volts. The transmit frequency was varied in 3 steps consisting of 1712.4, 1732.4 and 1752.6 MHz for the UMTS band 4. This frequency was recorded in MHz and deviation from nominal, in Parts Per Million. After the initial one-hour soak at the beginning of the tests, a period of thirty minutes soak was initialized between each ascending temperature step, before proceeding to the next measurement test cycle.

	EMI Test Report for the BlackBerry® smartphone Model RDU71CW, RDV71UW APPENDIX 3C	
<b>Test Report No.</b> RTS-3933-1105-43B_Rev1	<b>Dates of Test</b> Feb 7 to March 22, May 6 to May 31 and June 19, 2011	<b>FCC ID:</b> L6ARDU70CW <b>IC:</b> 2503A-RDU70CW <b>FCC ID:</b> L6ARDV70UW <b>IC:</b> 2503A-RDV70UW

PROCEDURE:

The test system software for commencing the Frequency Stability Tests carried through the following cycle.

15. Switch on the HP 6632B power supply; CMU 200 Communications test Set, and Environmental Chamber.
16. Start test program
17. Set the Temperature to –30°C and maintain a period of one- hour soak time, with the EUT supply voltage disabled.
18. Set power supply voltage to 3.6 volts.
19. Set up CMU 200 Radio Communication Tester.
20. Command the CMU 200 to switch to the low channel.
21. Enable the voltage to the EUT, and connect a link to the CMU 200 test set.
22. EUT is commanded to Transmit 100 Bursts.
23. Software logs the following data from the CMU 200, power supply and temperature chamber: Traffic Channel Number, Traffic Channel Frequency, Power Level, Chamber Temperature, Supply Voltage, Power and Frequency Error.
24. The CMU 200 commands the EUT to change frequency to the middle channel and high channel and repeats steps 7 to 9.
25. Repeat steps 5 to 10 changing the supply voltage to 3.7 Volts
26. Increase temperature by 10°C and soak for 1/2 hour.
27. Repeat steps 4 - 12 for temperatures –30°C to 60°C.
28. Repeat steps 5 to 10 changing the supply voltage to 4.2 volts

Procedure 5 to 10 was repeated at room temperature (20°C) with the power supply voltage set to 3.6, 3.7 and 4.2 volts

The maximum frequency error in the UMTS band 4 measured was **-0.0341 PPM**.



**Test Report No.**  
RTS-3933-1105-43B\_Rev1

**Dates of Test**  
Feb 7 to March 22, May 6 to May 31 and June 19, 2011

**FCC ID:** L6ARDU70CW **IC:** 2503A-RDU70CW  
**FCC ID:** L6ARDV70UW **IC:** 2503A-RDV70UW

UMTS Band 4 Channel results: channels 1312, 1412 and 1513 @ 20°C maximum transmitted power

Traffic Channel Number	UMTS band 4 Frequency (MHz)	Voltage (Volts)	Temperature (Celsius)	Frequency Error (Hz)	PPM
1312	1712.4	3.6	20	25	0.0146
1412	1732.4	3.6	20	-32	-0.0185
1513	1752.6	3.6	20	-33	-0.0188

Traffic Channel Number	UMTS band 4 Frequency (MHz)	Voltage (Volts)	Temperature (Celsius)	Frequency Error (Hz)	PPM
1312	1712.4	3.7	20	-34.00	-0.0199
1412	1732.4	3.7	20	32.00	0.0185
1513	1752.6	3.7	20	32.00	0.0183

Traffic Channel Number	UMTS band 5 Frequency (MHz)	Voltage (Volts)	Temperature (Celsius)	Frequency Error (Hz)	PPM
1312	1712.4	4.2	20	41.00	0.0239
1412	1732.4	4.2	20	-36.00	-0.0208
1513	1752.6	4.2	20	34.00	0.0194





**Test Report No.**  
RTS-3933-1105-43B\_Rev1

**Dates of Test**  
Feb 7 to March 22, May 6 to May 31 and June 19, 2011

**FCC ID:** L6ARDU70CW **IC:** 2503A-RDU70CW  
**FCC ID:** L6ARDV70UW **IC:** 2503A-RDV70UW

UMTS band 4 Results: channel 1312 @ maximum transmitted power

Traffic Channel Number	Frequency (MHz)	Voltage (Volts)	Temperature (Celsius)	Frequency Error (Hz)	PPM
1312	1712.4	3.6	-30	35.00	0.0204
1312	1712.4	3.6	-20	-37.00	-0.0216
1312	1712.4	3.6	-10	-46.00	-0.0269
1312	1712.4	3.6	0	-38.00	-0.0222
1312	1712.4	3.6	10	-40.00	-0.0234
1312	1712.4	3.6	20	-33.00	-0.0193
1312	1712.4	3.6	30	-36.00	-0.0210
1312	1712.4	3.6	40	29.00	0.0169
1312	1712.4	3.6	50	28.00	0.0164
1312	1712.4	3.6	60	36.00	0.0210

Traffic Channel Number	Frequency (MHz)	Voltage (Volts)	Temperature (Celsius)	Frequency Error (Hz)	PPM
1312	1712.4	3.7	-30	30.00	0.0175
1312	1712.4	3.7	-20	-35.00	-0.0204
1312	1712.4	3.7	-10	-41.00	-0.0239
1312	1712.4	3.7	0	-42.00	-0.0245
1312	1712.4	3.7	10	-40.00	-0.0234
1312	1712.4	3.7	20	-34.00	-0.0199
1312	1712.4	3.7	30	32.00	0.0187
1312	1712.4	3.7	40	38.00	0.0222
1312	1712.4	3.7	50	28.00	0.0164
1312	1712.4	3.7	60	33.00	0.0193

Traffic Channel Number	Frequency (MHz)	Voltage (Volts)	Temperature (Celsius)	Frequency Error (Hz)	PPM
1312	1712.4	4.2	-30	30.00	-0.0228
1312	1712.4	4.2	-20	-34.00	-0.0199
1312	1712.4	4.2	-10	-39.00	-0.0228
1312	1712.4	4.2	0	-41.00	-0.0239
1312	1712.4	4.2	10	-42.00	-0.0245
1312	1712.4	4.2	20	41.00	0.0239
1312	1712.4	4.2	30	27.00	0.0158
1312	1712.4	4.2	40	41.00	0.0239
1312	1712.4	4.2	50	34.00	0.0199
1312	1712.4	4.2	60	25.00	0.0146



**Test Report No.**  
RTS-3933-1105-43B\_Rev1

**Dates of Test**  
Feb 7 to March 22, May 6 to May 31 and June 19, 2011

**FCC ID:** L6ARDU70CW **IC:** 2503A-RDU70CW  
**FCC ID:** L6ARDV70UW **IC:** 2503A-RDV70UW

UMTS band 4 Results: channel 1412 @ maximum transmitted power

Traffic Channel Number	Frequency (MHz)	Voltage (Volts)	Temperature (Celsius)	Frequency Error (Hz)	PPM
1412	1732.4	3.6	-30	-27.00	-0.0156
1412	1732.4	3.6	-20	-33.00	-0.0190
1412	1732.4	3.6	-10	38.00	0.0219
1412	1732.4	3.6	0	-31.00	-0.0179
1412	1732.4	3.6	10	-50.00	-0.0289
1412	1732.4	3.6	20	-27.00	-0.0156
1412	1732.4	3.6	30	-32.00	-0.0185
1412	1732.4	3.6	40	27.00	0.0156
1412	1732.4	3.6	50	33.00	0.0190
1412	1732.4	3.6	60	32.00	0.0185

Traffic Channel Number	Frequency (MHz)	Voltage (Volts)	Temperature (Celsius)	Frequency Error (Hz)	PPM
1412	1732.4	3.7	-30	-37.00	-0.0214
1412	1732.4	3.7	-20	25.00	0.0144
1412	1732.4	3.7	-10	-46.00	-0.0266
1412	1732.4	3.7	0	33.00	0.0190
1412	1732.4	3.7	10	30.00	0.0173
1412	1732.4	3.7	20	32.00	0.0185
1412	1732.4	3.7	30	27.00	0.0156
1412	1732.4	3.7	40	33.00	0.0190
1412	1732.4	3.7	50	32.00	0.0185
1412	1732.4	3.7	60	32.00	0.0185

Traffic Channel Number	Frequency (MHz)	Voltage (Volts)	Temperature (Celsius)	Frequency Error (Hz)	PPM
1412	1732.4	4.2	-30	-25.00	-0.0144
1412	1732.4	4.2	-20	-31.00	-0.0179
1412	1732.4	4.2	-10	-31.00	-0.0179
1412	1732.4	4.2	0	-59.00	<b>-0.0341</b>
1412	1732.4	4.2	10	-28.00	-0.0162
1412	1732.4	4.2	20	-36.00	-0.0208
1412	1732.4	4.2	30	-28.00	-0.0162
1412	1732.4	4.2	40	31.00	0.0179
1412	1732.4	4.2	50	-35.00	-0.0202
1412	1732.4	4.2	60	-34.00	-0.0196



**Test Report No.**  
RTS-3933-1105-43B\_Rev1

**Dates of Test**  
Feb 7 to March 22, May 6 to May 31 and June 19, 2011

**FCC ID:** L6ARDU70CW **IC:** 2503A-RDU70CW  
**FCC ID:** L6ARDV70UW **IC:** 2503A-RDV70UW

UMTS band 4 Results: channel 1513 @ maximum transmitted power

Traffic Channel Number	Frequency (MHz)	Voltage (Volts)	Temperature (Celsius)	Frequency Error (Hz)	PPM
1513	1752.6	3.6	-30	-30.00	-0.0171
1513	1752.6	3.6	-20	35.00	0.0200
1513	1752.6	3.6	-10	43.00	0.0245
1513	1752.6	3.6	0	55.00	0.0314
1513	1752.6	3.6	10	40.00	0.0228
1513	1752.6	3.6	20	31.00	0.0177
1513	1752.6	3.6	30	-32.00	-0.0183
1513	1752.6	3.6	40	-33.00	-0.0188
1513	1752.6	3.6	50	-34.00	-0.0194
1513	1752.6	3.6	60	-31.00	-0.0177

Traffic Channel Number	Frequency (MHz)	Voltage (Volts)	Temperature (Celsius)	Frequency Error (Hz)	PPM
1513	1752.6	3.7	-30	-35.00	-0.0200
1513	1752.6	3.7	-20	38.00	0.0217
1513	1752.6	3.7	-10	41.00	0.0234
1513	1752.6	3.7	0	42.00	0.0240
1513	1752.6	3.7	10	54.00	0.0308
1513	1752.6	3.7	20	32.00	0.0183
1513	1752.6	3.7	30	29.00	0.0165
1513	1752.6	3.7	40	-40.00	-0.0228
1513	1752.6	3.7	50	-35.00	-0.0200
1513	1752.6	3.7	60	-32.00	-0.0183

Traffic Channel Number	Frequency (MHz)	Voltage (Volts)	Temperature (Celsius)	Frequency Error (Hz)	PPM
1513	1752.6	4.2	-30	-29.00	-0.0165
1513	1752.6	4.2	-20	45.00	0.0257
1513	1752.6	4.2	-10	41.00	0.0234
1513	1752.6	4.2	0	56.00	0.0320
1513	1752.6	4.2	10	49.00	0.0280
1513	1752.6	4.2	20	34.00	0.0194
1513	1752.6	4.2	30	27.00	0.0154
1513	1752.6	4.2	40	-40.00	-0.0228
1513	1752.6	4.2	50	-32.00	-0.0183
1513	1752.6	4.2	60	-23.00	-0.0131

## APPENDIX 4A – CDMA RADIATED EMISSIONS TEST DATA

**Test Report No.**  
RTS-3933-1105-43B\_Rev1

**Dates of Test**  
Feb 7 to March 22, May 6 to May 31 and June 19, 2011

**FCC ID:** L6ARDU70CW **IC:** 2503A-RDU70CW  
**FCC ID:** L6ARDV70UW **IC:** 2503A-RDV70UW

### Radiated Power Test Data Results

The following test configurations were measured for model RDU71CW:

Date of Test: May 06, 2011

The following measurements were performed by Quan (Jerry) Ma.

The environmental tests conditions were: Temperature: 23.2 °C  
Relative Humidity: 30.2%

The BlackBerry® smartphone - was in standalone, USB up position.  
Test distance is 3.0 metres

#### **Cellular Loopback Service Mode**

EUT				Rx Antenna		Spectrum Analyzer		Substitution Method					
Type	Ch	Frequency (MHz)	Band	Type	Pol.	Reading (dBuV)	Max (V,H) (dBuV)	Tracking Generator		Corrected Reading (relative to Dipole)		Limit (dBm)	Diff. To Limit (dB)
								Pol. Tx-Rx	Reading (dBm)	(dBm)	(W)		
F0	1013	824.70	Cell	Dipole	V	71.45	82.98	V-V	9.78	28.09	0.64	39.0	-10.9
F0	1013	824.70	Cell	Dipole	H	82.98		H-H	7.56				
F0	384	836.52	Cell	Dipole	V	71.34	82.78	V-V	10.71	<b>28.72</b>	<b>0.75</b>	<b>39.0</b>	<b>-10.3</b>
F0	384	836.52	Cell	Dipole	H	82.78		H-H	8.26				
F0	777	848.32	Cell	Dipole	V	71.15	81.81	V-V	8.71	26.73	0.47	39.0	-12.3
F0	777	848.32	Cell	Dipole	H	81.81		H-H	7.27				

#### **Cellular EVDO Mode**

EUT				Rx Antenna		Spectrum Analyzer		Substitution Method					
Type	Ch	Frequency (MHz)	Band	Type	Pol.	Reading (dBuV)	Max (V,H) (dBuV)	Tracking Generator		Corrected Reading (relative to Dipole)		Limit (dBm)	Diff. To Limit (dB)
								Pol. Tx-Rx	Reading (dBm)	(dBm)	(W)		
F0	1013	824.70	Cell	Dipole	V	80.68	80.68	V-V	7.71	26.02	0.40	39.0	-13.0
F0	1013	824.70	Cell	Dipole	H	76.35		H-H	5.50				
F0	384	836.52	Cell	Dipole	V	80.43	80.43	V-V	8.37	<b>26.38</b>	<b>0.44</b>	<b>39.0</b>	<b>-12.6</b>
F0	384	836.52	Cell	Dipole	H	76.05		H-H	6.42				
F0	777	848.32	Cell	Dipole	V	80.88	80.88	V-V	8.09	26.11	0.41	39.0	-13.9
F0	777	848.32	Cell	Dipole	H	74.59		H-H	6.69				

**Test Report No.**  
RTS-3933-1105-43B\_Rev1

**Dates of Test**  
Feb 7 to March 22, May 6 to May 31 and June 19, 2011

**FCC ID:** L6ARDU70CW **IC:** 2503A-RDU70CW  
**FCC ID:** L6ARDV70UW **IC:** 2503A-RDV70UW

Radiated Power Test Data Results cont'd

Date of Test: May 06, 2011

The following measurements were performed by Quan (Jerry) Ma.

The environmental tests conditions were: Temperature: 23.2 °C  
Relative Humidity: 30.2%


The BlackBerry® smartphone - was in standalone, USB down position.  
Test distance is 3.0 metres

**PCS Loopback Service Mode**

								Substitution Method					
EUT				Receive Antenna		Spectrum Analyzer		Tracking Generator					
Type	Ch	Frequency (MHz)	Band	Type	Pol.	Reading (dBuV)	Max (V,H) (dBuV)	Pol. Tx-Rx	Reading (dBm)	(dBm)	(W)	Limit (dBm)	Diff to Limit (dB)
F0	25	1851.25	PCS	Horn	V	83.92	85.56	VV	-13.09	27.41	0.55	33.00	-5.60
F0	25	1851.25	PCS	Horn	H	85.56		HH	-11.98				
F0	600	1880.00	PCS	Horn	V	85.21	85.87	VV	-12.26	<b>27.82</b>	<b>0.61</b>	<b>33.00</b>	<b>-5.20</b>
F0	600	1880.00	PCS	Horn	H	85.87		HH	-11.45				
F0	1175	1908.75	PCS	Horn	V	84.54	84.8	VV	-13.07	26.97	0.50	33.00	-6.00
F0	1175	1908.75	PCS	Horn	H	84.8		HH	-12.35				

**PCS EVDO Mode**

								Substitution Method					
EUT				Receive Antenna		Spectrum Analyzer		Tracking Generator					
Type	Ch	Frequency (MHz)	Band	Type	Pol.	Reading (dBuV)	Max (V,H) (dBuV)	Pol. Tx-Rx	Reading (dBm)	(dBm)	(W)	Limit (dBm)	Diff to Limit (dB)
F0	25	1851.25	PCS	Horn	V	88.65	88.65	VV	-9.87	30.8	1.20	33.00	-2.20
F0	25	1851.25	PCS	Horn	H	82.05		HH	-8.59				
F0	600	1880.00	PCS	Horn	V	89.3	89.3	VV	-8.98	<b>31.1</b>	<b>1.29</b>	<b>33.00</b>	<b>-1.90</b>
F0	600	1880.00	PCS	Horn	H	84.78		HH	-8.17				
F0	1175	1908.75	PCS	Horn	V	87.82	87.82	VV	-9.98	29.85	0.97	33.00	-3.20
F0	1175	1908.75	PCS	Horn	H	84.96		HH	-9.47				

	EMI Test Report for the BlackBerry® smartphone Model RDU71CW, RDV71UW APPENDIX 4A	
<b>Test Report No.</b> RTS-3933-1105-43B_Rev1	<b>Dates of Test</b> Feb 7 to March 22, May 6 to May 31 and June 19, 2011	<b>FCC ID:</b> L6ARDU70CW <b>IC:</b> 2503A-RDU70CW <b>FCC ID:</b> L6ARDV70UW <b>IC:</b> 2503A-RDV70UW

Radiated Emissions Test Data Results cont'd

**Cellular Loopback Service Mode**

Date of Test: May 6, 2011

The following measurements were performed by Quan (Jerry) Ma

The environmental test conditions were: Temperature: 24.1 °C  
Relative Humidity: 29.3 %

Test Distance was 3.0 metres with a height of 1-4 metres, and a frequency range of 30 MHz to 1000 MHz.

The BlackBerry® smartphone was in standalone, Vertical position.

The following measurements were performed in CDMA Cellular Loopback Tx mode on channels 1013, 384 and 777.

All emissions had a test margin greater than 25.0 dB.

Date of Test: March 16, 2011

The following measurements were performed by Adam Rusinek


The environmental test conditions were: Temperature: 26.0°C  
Relative Humidity: 33.6 %

Test Distance was 3.0 metres with a height of 1-4 metres, and a frequency range of 1-9GHz.

The BlackBerry® smartphone was in standalone, Vertical position.

The following measurements were performed in CDMA Cellular Loopback Tx mode on channels 1013, 384 and 777.

All emissions had a test margin greater than 25.0 dB.

	EMI Test Report for the BlackBerry® smartphone Model RDU71CW, RDV71UW APPENDIX 4A	
<b>Test Report No.</b> RTS-3933-1105-43B_Rev1	<b>Dates of Test</b> Feb 7 to March 22, May 6 to May 31 and June 19, 2011	<b>FCC ID:</b> L6ARDU70CW <b>IC:</b> 2503A-RDU70CW <b>FCC ID:</b> L6ARDV70UW <b>IC:</b> 2503A-RDV70UW

Radiated Emissions Test Data Results cont'd

**Cellular 1xEVDO Mode**

Date of Test: May 6, 2011

The following measurements were performed by Kevin Rose

The environmental test conditions were: Temperature: 25.2 °C  
Relative Humidity: 31.1 %

Test Distance was 3.0 metres with a height of 1-4 metres, and a frequency range of 30 MHz to 1000 MHz.

The BlackBerry® smartphone was in standalone, Vertical position.

The following measurements were performed in CDMA Cellular EVDO Tx mode on channels 1013, 384 and 777.

All emissions had a test margin greater than 25.0 dB.

Date of Test: March 17, 2011

The following measurements were performed by Adam Rusinek

The environmental test conditions were: Temperature: 26.4°C  
Relative Humidity: 32.6 %


Test Distance was 3.0 metres with a height of 1-4 metres, and a frequency range of 1-9GHz.

The BlackBerry® smartphone was in standalone, Vertical position.

The following measurements were performed in CDMA Cellular EVDO Tx mode on channels 1013, 384 and 777.

All emissions had a test margin greater than 25.0 dB.



	EMI Test Report for the BlackBerry® smartphone Model RDU71CW, RDV71UW APPENDIX 4A	
<b>Test Report No.</b> RTS-3933-1105-43B_Rev1	<b>Dates of Test</b> Feb 7 to March 22, May 6 to May 31 and June 19, 2011	<b>FCC ID:</b> L6ARDU70CW <b>IC:</b> 2503A-RDU70CW <b>FCC ID:</b> L6ARDV70UW <b>IC:</b> 2503A-RDV70UW

Radiated Emissions Test Data Results cont'd

**PCS Loopback Service Mode**

Date of Test: May 6, 2011

The following measurements were performed by Quan (Jerry) Ma

The environmental test conditions were: Temperature: 25.2 °C  
Relative Humidity: 29.0 %

Test Distance was 3.0 metres with a height of 1-4 metres, and a frequency range of 30 MHz to 1000 MHz.

The BlackBerry® smartphone was in standalone, USB up position.

The following measurements were performed in PCS Tx mode on channels 25, 600 and 1175.

All emissions had a test margin greater than 25.0 dB.

Date of Test: March 22, 2011

The following measurements were performed by Adam Rusinek


The environmental test conditions were: Temperature: 26.5°C  
Relative Humidity: 30.2 %

Test Distance was 3.0 metres with a height of 1-4 metres, and a frequency range of 1-20GHz.

The BlackBerry® smartphone was in standalone, USB up position.

The following measurements were performed in PCS Tx mode on channels 25, 600 and 1175.

All emissions had a test margin greater than 25.0 dB.

	EMI Test Report for the BlackBerry® smartphone Model RDU71CW, RDV71UW APPENDIX 4A	
<b>Test Report No.</b> RTS-3933-1105-43B_Rev1	<b>Dates of Test</b> Feb 7 to March 22, May 6 to May 31 and June 19, 2011	<b>FCC ID:</b> L6ARDU70CW <b>IC:</b> 2503A-RDU70CW <b>FCC ID:</b> L6ARDV70UW <b>IC:</b> 2503A-RDV70UW

Radiated Emissions Test Data Results cont'd

**PCS 1xEVDO Mode**

Date of Test: May 06, 2011

The following measurements were performed by Kevin Rose

The environmental test conditions were: Temperature: 25.1 °C  
Relative Humidity: 30.0 %

Test Distance was 3.0 metres with a height of 1-4 metres, a frequency range of 30 MHz to 1000 MHz.

The BlackBerry® smartphone was in standalone, USB up position.

The following measurements were performed in PCS Tx mode on channels 25, 600 and 1175.

All emissions had a test margin greater than 25.0 dB.

Date of Test: March 22, 2011

The following measurements were performed by Heng Lin.

The environmental test conditions were: Temperature: 26.3°C  
Relative Humidity: 38.2%


Test Distance was 3.0 metres with a height of 1-4 metres, a frequency range of 1-20GHz.

The BlackBerry® smartphone was in standalone, USB up position.

The following measurements were performed in PCS Tx mode on channels 25, 600 and 1175.

All emissions had a test margin greater than 25.0 dB.

## APPENDIX 4B – UMTS RADIATED EMISSIONS TEST DATA

	EMI Test Report for the BlackBerry® smartphone Model RDU71CW, RDV71UW APPENDIX 4B	
	<b>Test Report No.</b> RTS-3933-1105-43B_Rev1	<b>Dates of Test</b> Feb 7 to March 22, May 6 to May 31 and June 19, 2011

### Radiated Power Test Data Results

The following test configurations were measured for model RDV71UW:

Date of Test: May 25, 2011

The following measurements were performed by Quan (Jerry) Ma.

The environmental tests conditions were: Temperature: 23.4 °C  
Relative Humidity: 36.1 %

The BlackBerry® smartphone - was in standalone, USB down position.  
Test distance is 3.0 metres


#### UMTS band 4 Call Service Mode

EUT				Rx Antenna		Spectrum Analyzer		Substitution Method						
Type	Ch	Frequency (MHz)	Band	Type	Pol.	Reading (dBuV)	Max (V,H) (dBuV)	Pol. Tx-Rx	Reading (dBm)	Tracking Generator		Limit (dBm)	Diff. To Limit (dB)	
										Corrected Reading (relative to Dipole)				
											(dBm)	(W)		
F0	1312	1712.40	4	Horn	V	74.42	87.21	V-V	-13.60	26.86	0.49	30	-3.1	
F0	1312	1712.40	4	Horn	H	87.21		H-H	-13.00					
F0	1413	1732.60	4	Horn	V	74.45	87.43	V-V	-13.30	<b>27.56</b>	<b>0.57</b>	<b>30</b>	<b>-2.4</b>	
F0	1413	1732.60	4	Horn	H	87.43		H-H	-12.60					
F0	1513	1752.60	4	Horn	V	75.22	85.7	V-V	-14.60	26.00	0.40	30	-4.0	
F0	1513	1752.60	4	Horn	H	85.7		H-H	-13.90					

#### UMTS band 4 HSUPA Mode

EUT				Rx Antenna		Spectrum Analyzer		Substitution Method						
Type	Ch	Frequency (MHz)	Band	Type	Pol.	Reading (dBuV)	Max (V,H) (dBuV)	Pol. Tx-Rx	Reading (dBm)	Tracking Generator		Limit (dBm)	Diff. To Limit (dB)	
										Corrected Reading (relative to Dipole)				
											(dBm)	(W)		
F0	1312	1712.40	4	Horn	V	76.83	88.58	V-V	-12.00	<b>28.36</b>	<b>0.69</b>	<b>30</b>	<b>-1.64</b>	
F0	1312	1712.40	4	Horn	H	88.58		H-H	-11.50					
F0	1413	1732.60	4	Horn	V	75.79	88.2	V-V	-12.50	28.26	0.67	30	-1.74	
F0	1413	1732.60	4	Horn	H	88.2		H-H	-11.90					
F0	1513	1752.60	4	Horn	V	77.34	87.52	V-V	-12.70	28.00	<b>0.63</b>	30	-2	
F0	1513	1752.60	4	Horn	H	87.52		H-H	-11.90					

This report shall NOT be reproduced except in full without the written consent of RIM Testing Services  
- A division of Research in Motion Limited.

	EMI Test Report for the BlackBerry® smartphone Model RDU71CW, RDV71UW APPENDIX 4B	
<b>Test Report No.</b> RTS-3933-1105-43B_Rev1	<b>Dates of Test</b> Feb 7 to March 22, May 6 to May 31 and June 19, 2011	<b>FCC ID:</b> L6ARDU70CW <b>IC:</b> 2503A-RDU70CW <b>FCC ID:</b> L6ARDV70UW <b>IC:</b> 2503A-RDV70UW

Radiated Emissions Test Data Results cont'd  
**UMTS band 4 Call Service Mode**

Date of Test: May 24, 2011

The following measurements were performed by Quan (Jerry) Ma

The environmental test conditions were: Temperature: 23.9 °C  
Relative Humidity: 35.6 %

Test Distance was 3.0 metres with a height of 1-4 metres, and a frequency range of 30MHz to 1000MHz.

The BlackBerry® smartphone was in standalone, vertical position.

The following measurements were performed in UMTS band 4 Call mode on channels 1312, 1413, 1513.

All emissions had a test margin greater than 25.0 dB.

Date of Test: May25, 2011

The following measurements were performed by Shou Wang


The environmental test conditions were: Temperature: 24.5 °C  
Relative Humidity: 40.6%

Test Distance was 3.0 metres with a height of 1-4 meters, and a frequency range of 1-20GHz.

The BlackBerry® smartphone was in standalone, USB Up position.

The following measurements were performed in UMTS band 4 Call mode on channels 1312, 1413, 1513.

All emissions had a test margin greater than 25.0 dB.

	EMI Test Report for the BlackBerry® smartphone Model RDU71CW, RDV71UW APPENDIX 4B	
<b>Test Report No.</b> RTS-3933-1105-43B_Rev1	<b>Dates of Test</b> Feb 7 to March 22, May 6 to May 31 and June 19, 2011	<b>FCC ID:</b> L6ARDU70CW <b>IC:</b> 2503A-RDU70CW <b>FCC ID:</b> L6ARDV70UW <b>IC:</b> 2503A-RDV70UW

Radiated Emissions Test Data Results cont'd  
UMTS band 4 HSUPA Mode

Date of Test: June 19, 2011

The following measurements were performed by Kevin Rose

The environmental test conditions were: Temperature: 23.9 °C  
Relative Humidity: 35.6 %

Test Distance was 3.0 metres with a height of 1-4 metres, and a frequency range of 30MHz to 1000MHz.

The BlackBerry® smartphone was in standalone, vertical position.

The following measurements were performed in UMTS band 4 HSUPA mode on channels 1413.

All emissions had a test margin greater than 25.0 dB.

Date of Test: May 31, 2011

The following measurements were performed by Adam Rusinek

The environmental test conditions were: Temperature: 24.5 °C  
Relative Humidity: 42.6 %

Test Distance was 3.0 metres with a height of 1-4 meters, and a frequency range of 1-20GHz.

The BlackBerry® smartphone was in standalone, USB down position.

The following measurements were performed in UMTS band 4 HSUPA mode on channel 1413.

All emissions had a test margin greater than 25.0 dB.