

**Plot 1**

Date/Time: 10/4/2011 2:10:51 PM, Date/Time: 10/4/2011 2:16:00 PM

**DUT: RDR61CW; Serial: MEID FED12**

Communication System: CDMA RC3; Frequency: 836.52 MHz

Medium parameters used:  $f = 836.52$  MHz;  $\sigma = 1.017$  mho/m;  $\epsilon_r = 55.87$ ;  $\rho = 1000$  kg/m<sup>3</sup>

Phantom section: Flat Section

DASY5 Configuration:

- Probe: ES3DV3 - SN3244; ConvF(6.05, 6.05, 6.05);
- Sensor-Surface: 3mm (Mechanical Surface Detection)
- Electronics: DAE4 Sn1233; Calibrated: 10/13/2010
- Phantom: ELI 4.0; Type: QDOVA001BA; Serial: xxxx
- Measurement SW: DASY52, Version 52.6 (2);

**Flat-Section MSL/Front 10mm 836/Area Scan (6x9x1):** Measurement grid: dx=15mm, dy=15mm

Maximum value of SAR (measured) = 0.497 mW/g

**Flat-Section MSL/Front 10mm 836/Zoom Scan (8x8x7)/Cube 0:** Measurement grid: dx=5mm, dy=5mm, dz=5mm

Reference Value = 19.711 V/m; Power Drift = -0.0056 dB

Peak SAR (extrapolated) = 0.609 W/kg

**SAR(1 g) = 0.449 mW/g; SAR(10 g) = 0.325 mW/g**

Maximum value of SAR (measured) = 0.500 mW/g

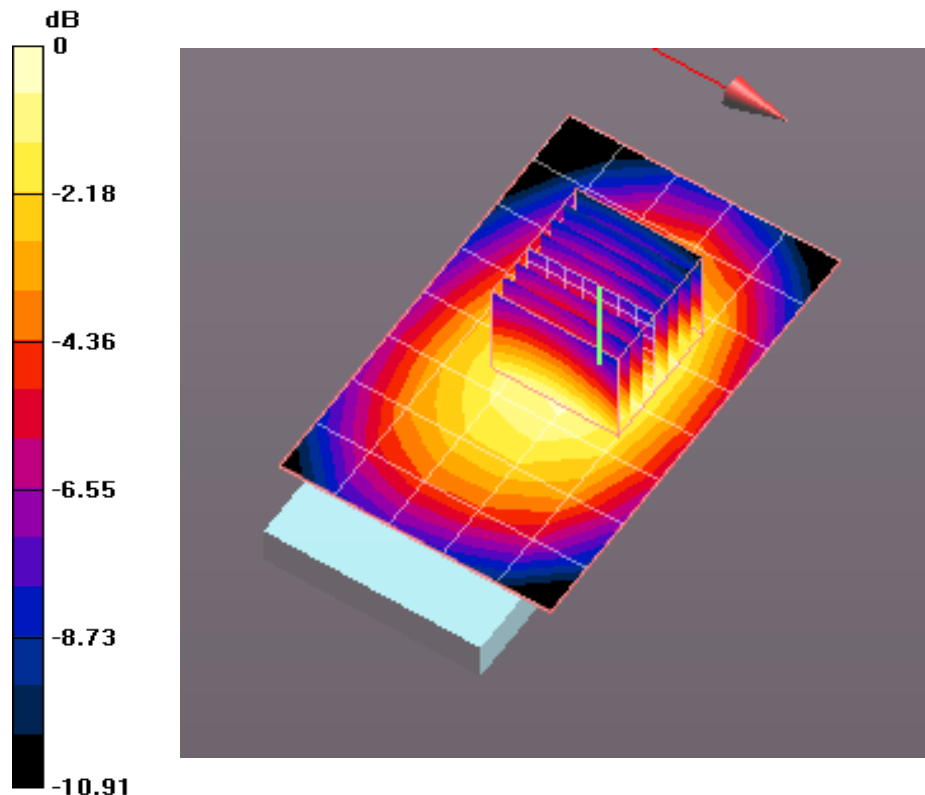

0 dB = 0.500mW/g

**Plot 2**

Date/Time: 10/4/2011 5:09:23 PM, Date/Time: 10/4/2011 5:14:34 PM

**CDMA BC0\_RDR61CW\_Back 10mm 836****DUT: RDR61CW; Serial: MEID FED12**

Communication System: CDMA RC3; Frequency: 836.52 MHz

Medium parameters used:  $f = 836.52$  MHz;  $\sigma = 1.017$  mho/m;  $\epsilon_r = 55.87$ ;  $\rho = 1000$  kg/m<sup>3</sup>

Phantom section: Flat Section

DASY5 Configuration:

- Probe: ES3DV3 - SN3244; ConvF(6.05, 6.05, 6.05);
- Sensor-Surface: 3mm (Mechanical Surface Detection)
- Electronics: DAE4 Sn1233; Calibrated: 10/13/2010
- Phantom: ELI 4.0; Type: QDOVA001BA; Serial: xxxx
- Measurement SW: DASY52, Version 52.6 (2);

**Flat-Section MSL/Back 10mm 836/Area Scan (6x9x1):** Measurement grid:

dx=15mm, dy=15mm

Maximum value of SAR (measured) = 0.714 mW/g

**Flat-Section MSL/Back 10mm 836/Zoom Scan (7x7x7)/Cube 0:** Measurement

grid: dx=5mm, dy=5mm, dz=5mm

Reference Value = 24.359 V/m; Power Drift = -0.17 dB

Peak SAR (extrapolated) = 0.866 W/kg

**SAR(1 g) = 0.629 mW/g; SAR(10 g) = 0.447 mW/g**

Maximum value of SAR (measured) = 0.707 mW/g

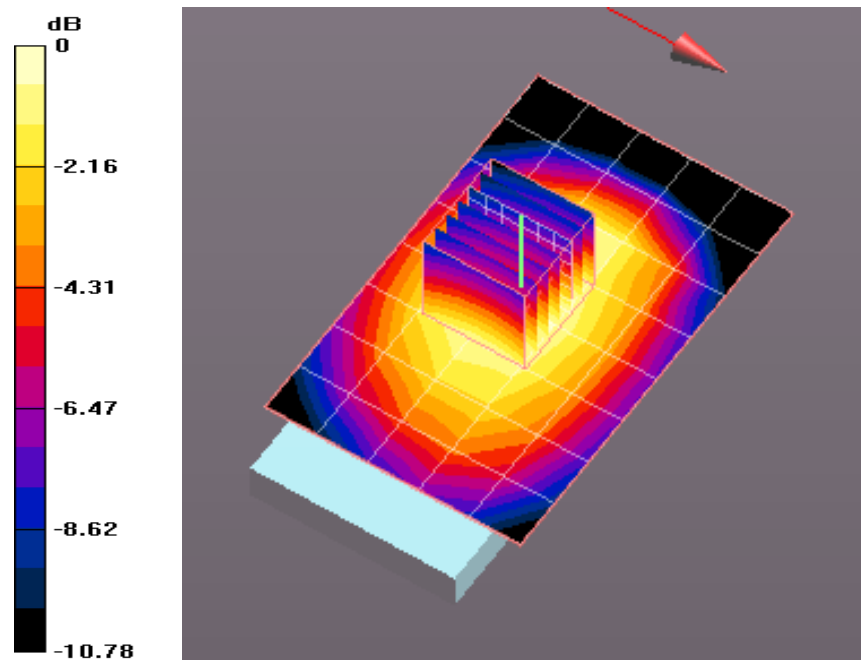

0 dB = 0.710mW/g

**Plot 3**

Date/Time: 10/4/2011 3:17:59 PM, Date/Time: 10/4/2011 3:22:18 PM

Test Laboratory: Cetecom Inc. SAR 1 Lab

**DUT: RDR61CW; Serial: MEID FED12**

Communication System: CDMA RC3; Frequency: 836.52 MHz

Medium parameters used:  $f = 836.52$  MHz;  $\sigma = 1.017$  mho/m;  $\epsilon_r = 55.87$ ;  $\rho = 1000$  kg/m<sup>3</sup>

Phantom section: Flat Section

Measurement Standard: DASYS (IEEE/IEC/ANSI C63.19-2007)

DASY52 Configuration:

- Probe: ES3DV3 - SN3244; ConvF(6.05, 6.05, 6.05); Calibrated: 10/13/2010
- Sensor-Surface: 3mm (Mechanical Surface Detection)
- Electronics: DAE4 Sn1233; Calibrated: 10/13/2010
- Phantom: ELI 4.0; Type: QDOVA001BA; Serial: xxxx
- DASY52 52.6.2(482); SEMCAD X 14.4.5(3634)

**Flat-Section MSL 2/Left Edge 10mm 836/Area Scan (9x5x1):** Measurement grid: dx=15mm, dy=15mm

Maximum value of SAR (measured) = 0.423 mW/g

**Flat-Section MSL 2/Left Edge 10mm 836/Zoom Scan (7x7x7)/Cube 0:** Measurement grid: dx=5mm, dy=5mm, dz=5mm

Reference Value = 21.074 V/m; Power Drift = -0.07 dB

Peak SAR (extrapolated) = 0.540 W/kg

**SAR(1 g) = 0.374 mW/g; SAR(10 g) = 0.254 mW/g**

Maximum value of SAR (measured) = 0.436 mW/g

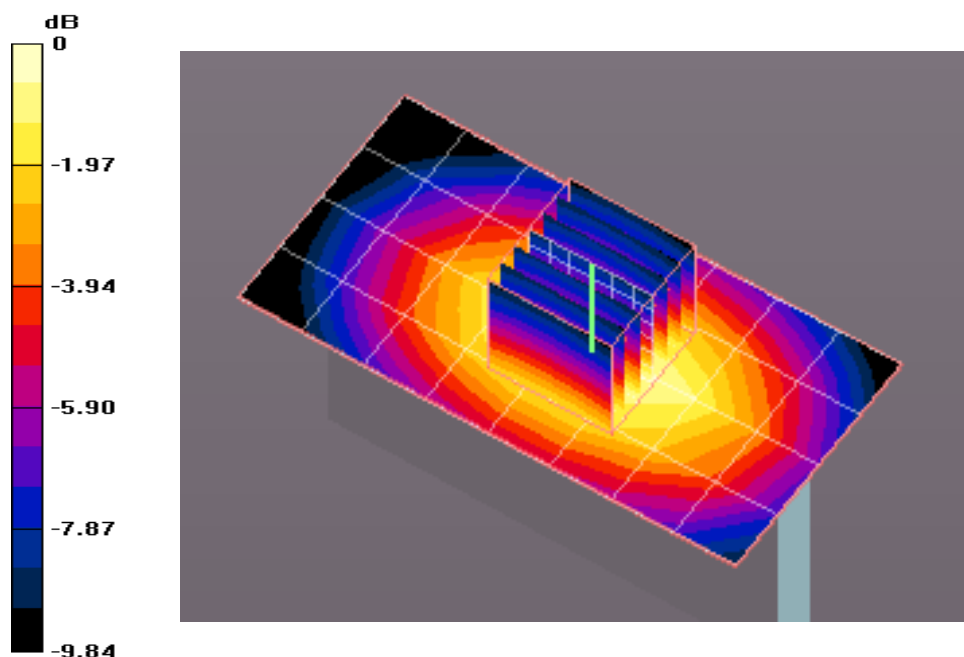

0 dB = 0.440mW/g

**Plot 4**

Date/Time: 10/4/2011 4:24:59 PM, Date/Time: 10/4/2011 4:29:19 PM

Test Laboratory: Cetecom Inc. SAR 1 Lab

**DUT: RDR61CW; Serial: MEID FED12**

Communication System: CDMA RC3; Frequency: 836.52 MHz

Medium parameters used:  $f = 836.52$  MHz;  $\sigma = 1.017$  mho/m;  $\epsilon_r = 55.87$ ;  $\rho = 1000$  kg/m<sup>3</sup>

Phantom section: Flat Section

Measurement Standard: DASYS (IEEE/IEC/ANSI C63.19-2007)

DASY52 Configuration:

- Probe: ES3DV3 - SN3244; ConvF(6.05, 6.05, 6.05); Calibrated: 10/13/2010
- Sensor-Surface: 3mm (Mechanical Surface Detection)
- Electronics: DAE4 Sn1233; Calibrated: 10/13/2010
- Phantom: ELI 4.0; Type: QDOVA001BA; Serial: xxxx
- DASY52 52.6.2(482); SEMCAD X 14.4.5(3634)

**Flat-Section MSL 2/Right Edge 10mm 836/Area Scan (9x5x1):** Measurement grid: dx=15mm, dy=15mm

Maximum value of SAR (measured) = 0.485 mW/g

**Flat-Section MSL 2/Right Edge 10mm 836/Zoom Scan (7x7x7)/Cube 0:** Measurement grid: dx=5mm, dy=5mm, dz=5mm

Reference Value = 22.355 V/m; Power Drift = -0.13 dB

Peak SAR (extrapolated) = 0.622 W/kg

**SAR(1 g) = 0.436 mW/g; SAR(10 g) = 0.302 mW/g**

Maximum value of SAR (measured) = 0.500 mW/g

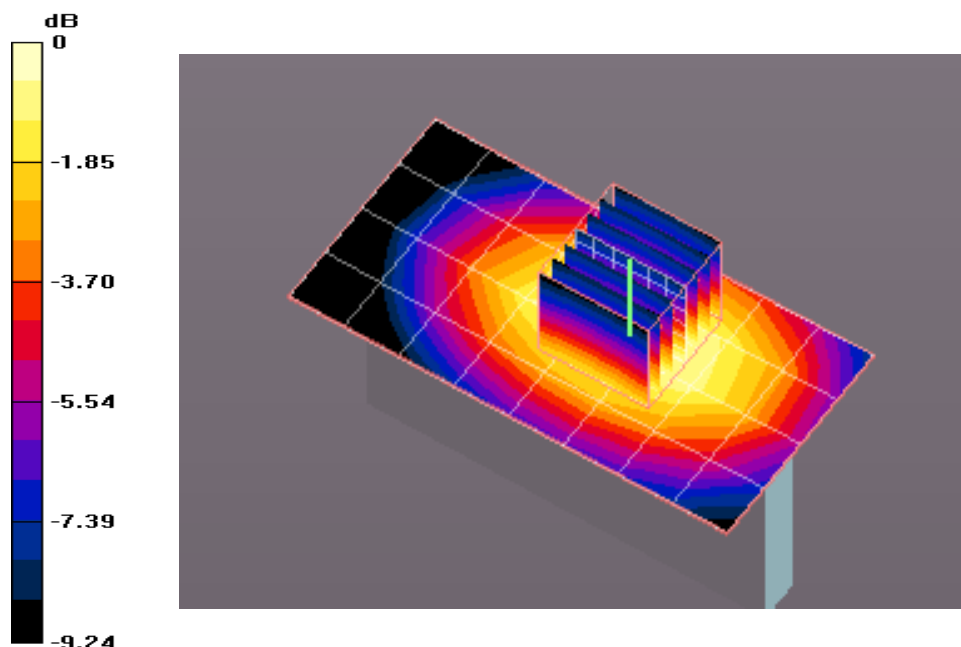

0 dB = 0.500mW/g

**Plot 5**

Date/Time: 10/4/2011 4:47:41 PM, Date/Time: 10/4/2011 4:50:37 PM

**DUT: RDR61CW; Serial: MEID FED12**

Communication System: CDMA RC3; Frequency: 836.52 MHz

Medium parameters used:  $f = 836.52$  MHz;  $\sigma = 1.017$  mho/m;  $\epsilon_r = 55.87$ ;  $\rho = 1000$  kg/m<sup>3</sup>

Phantom section: Flat Section

DASY5 Configuration:

- Probe: ES3DV3 - SN3244; ConvF(6.05, 6.05, 6.05);
- Sensor-Surface: 3mm (Mechanical Surface Detection)
- Electronics: DAE4 Sn1233; Calibrated: 10/13/2010
- Phantom: ELI 4.0; Type: QDOVA001BA; Serial: xxxx
- Measurement SW: DASY52, Version 52.6 (2);

**Flat-Section MSL/Bottom 10mm 836/Area Scan (6x5x1):** Measurement grid: dx=15mm, dy=15mm

Maximum value of SAR (measured) = 0.092 mW/g

**Flat-Section MSL/Bottom 10mm 836/Zoom Scan (7x7x7)/Cube 0:** Measurement grid: dx=5mm, dy=5mm, dz=5mm

Reference Value = 9.329 V/m; Power Drift = 0.17 dB

Peak SAR (extrapolated) = 0.183 W/kg

**SAR(1 g) = 0.094 mW/g; SAR(10 g) = 0.057 mW/g**

Maximum value of SAR (measured) = 0.115 mW/g

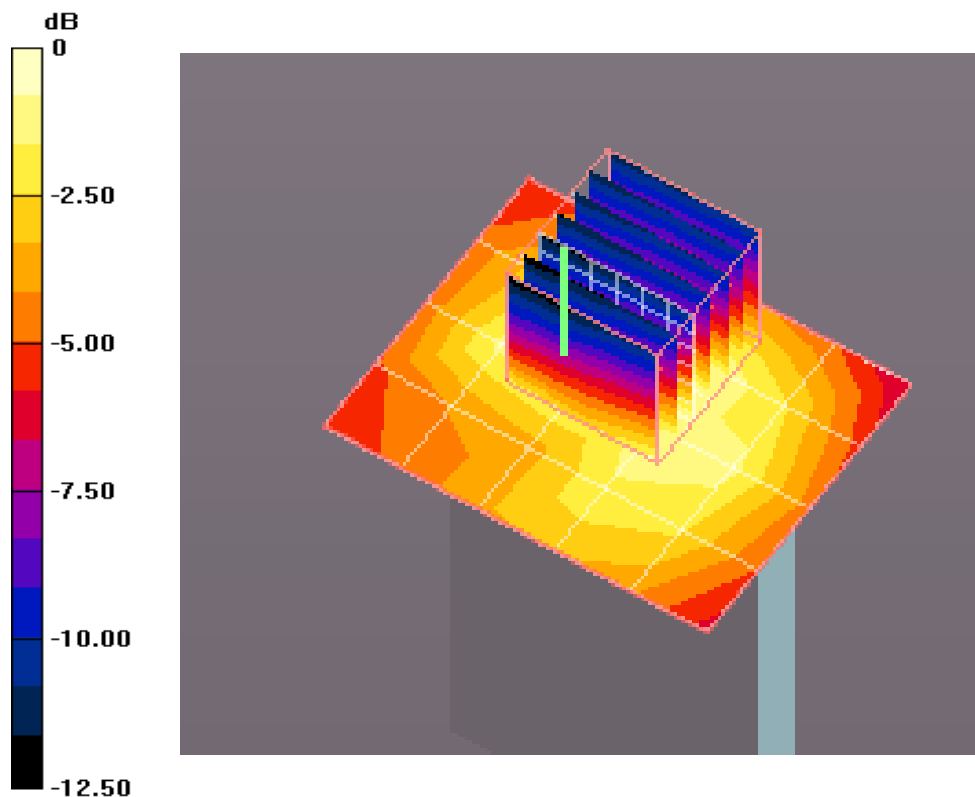

0 dB = 0.110mW/g

**Plot 6**

Date/Time: 10/5/2011 12:34:25 PM, Date/Time: 10/5/2011 12:38:19 PM

Test Laboratory: Cetecom Inc., SAR 3 Lab

**DUT: RDR61CW; Serial: MEID FED12**

Communication System: CDMA2000 RC3; Frequency: 1880 MHz

Medium parameters used:  $f = 1880$  MHz;  $\sigma = 1.471$  mho/m;  $\epsilon_r = 52.96$ ;  $\rho = 1000$  kg/m<sup>3</sup>

Phantom section: Flat Section

Measurement Standard: DASYS (IEEE/IEC/ANSI C63.19-2007)

DASY52 Configuration:

- Probe: ES3DV3 - SN3261; ConvF(4.8, 4.8, 4.8); Calibrated: 5/30/2011
- Sensor-Surface: 3mm (Mechanical Surface Detection)
- Electronics: DAE4 Sn1266; Calibrated: 5/30/2011
- Phantom: ELI v5.0; Type: QDOVA002AA; Serial: TP:1124
- DASY52 52.6.2(482); SEMCAD X 14.4.5(3634)

**Flat-Section MSL/Front 10mm\_Mid Channel/Area Scan (11x7x1):** Measurement grid: dx=15mm, dy=15mm

Maximum value of SAR (measured) = 0.715 mW/g

**Flat-Section MSL/Front 10mm\_Mid Channel/Zoom Scan (7x7x7)/Cube 0:** Measurement grid: dx=5mm, dy=5mm, dz=5mm

Reference Value = 10.733 V/m; Power Drift = 0.11 dB

Peak SAR (extrapolated) = 1.086 W/kg

**SAR(1 g) = 0.680 mW/g; SAR(10 g) = 0.410 mW/g**

Maximum value of SAR (measured) = 0.808 mW/g

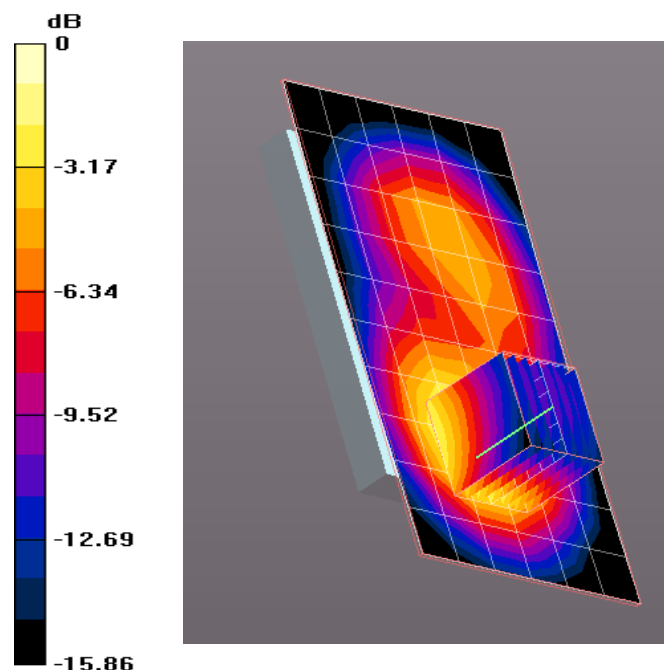

0 dB = 0.810mW/g

**Plot 7**

Date/Time: 10/5/2011 11:34:50 AM, Date/Time: 10/5/2011 11:42:08 AM

Test Laboratory: Cetecom Inc., SAR 3 Lab

**DUT: RDR61CW; Serial: MEID FED12**

Communication System: CDMA2000 RC3; Frequency: 1880 MHz

Medium parameters used:  $f = 1880$  MHz;  $\sigma = 1.471$  mho/m;  $\epsilon_r = 52.96$ ;  $\rho = 1000$  kg/m<sup>3</sup>

Phantom section: Flat Section

Measurement Standard: DASYS (IEEE/IEC/ANSI C63.19-2007)

DASY52 Configuration:

- Probe: ES3DV3 - SN3261; ConvF(4.8, 4.8, 4.8); Calibrated: 5/30/2011
- Sensor-Surface: 3mm (Mechanical Surface Detection)
- Electronics: DAE4 Sn1266; Calibrated: 5/30/2011
- Phantom: ELI v5.0; Type: QDOVA002AA; Serial: TP:1124
- DASY52 52.6.2(482); SEMCAD X 14.4.5(3634)

**Flat-Section MSL/Back 10mm\_Mid Channel/Area Scan (11x7x1):** Measurement grid: dx=15mm, dy=15mm

Maximum value of SAR (measured) = 1.024 mW/g

**Flat-Section MSL/Back 10mm\_Mid Channel/Zoom Scan (7x7x7)/Cube 0:** Measurement grid: dx=5mm, dy=5mm, dz=5mm

Reference Value = 11.737 V/m; Power Drift = 0.12 dB

Peak SAR (extrapolated) = 1.569 W/kg

**SAR(1 g) = 0.939 mW/g; SAR(10 g) = 0.569 mW/g**

Maximum value of SAR (measured) = 1.126 mW/g

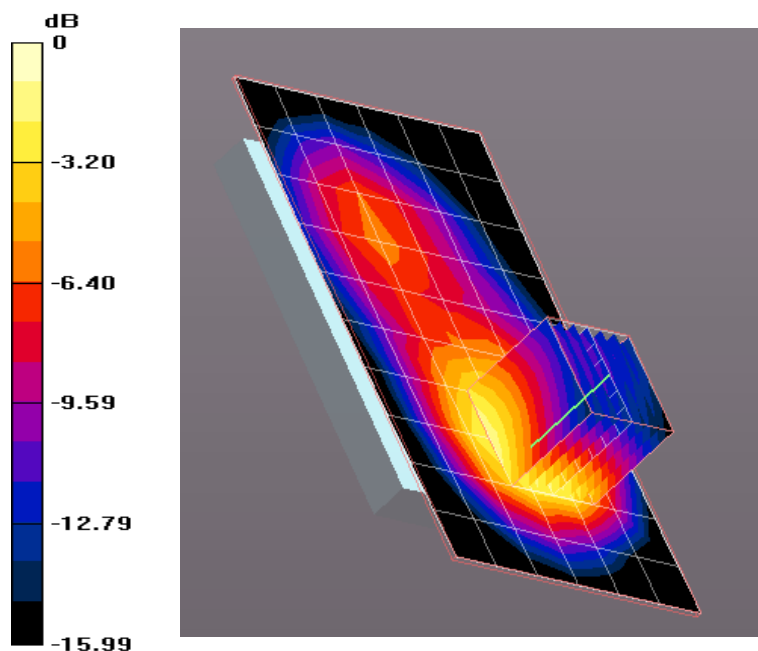

0 dB = 1.130mW/g

**Plot 8**

Date/Time: 10/5/2011 1:02:13 PM, Date/Time: 10/5/2011 1:08:32 PM

Test Laboratory: Cetecom Inc., SAR 3 Lab

**DUT: RDR61CW; Serial: MEID FED12**

Communication System: CDMA2000 RC3; Frequency: 1880 MHz

Medium parameters used:  $f = 1880$  MHz;  $\sigma = 1.471$  mho/m;  $\epsilon_r = 52.96$ ;  $\rho = 1000$  kg/m<sup>3</sup>

Phantom section: Flat Section

Measurement Standard: DASYS (IEEE/IEC/ANSI C63.19-2007)

DASY52 Configuration:

- Probe: ES3DV3 - SN3261; ConvF(4.8, 4.8, 4.8); Calibrated: 5/30/2011
- Sensor-Surface: 3mm (Mechanical Surface Detection)
- Electronics: DAE4 Sn1266; Calibrated: 5/30/2011
- Phantom: ELI v5.0; Type: QDOVA002AA; Serial: TP:1124
- DASY52 52.6.2(482); SEMCAD X 14.4.5(3634)

**Flat-Section MSL 2/Left Side 10mm\_Mid Channel/Area Scan (11x6x1):** Measurement grid: dx=15mm, dy=15mm

Maximum value of SAR (measured) = 0.199 mW/g

**Flat-Section MSL 2/Left Side 10mm\_Mid Channel/Zoom Scan (7x7x7)/Cube 0:** Measurement grid: dx=5mm, dy=5mm, dz=5mm

Reference Value = 10.669 V/m; Power Drift = 0.21 dB

Peak SAR (extrapolated) = 0.308 W/kg

**SAR(1 g) = 0.195 mW/g; SAR(10 g) = 0.116 mW/g**

Maximum value of SAR (measured) = 0.232 mW/g

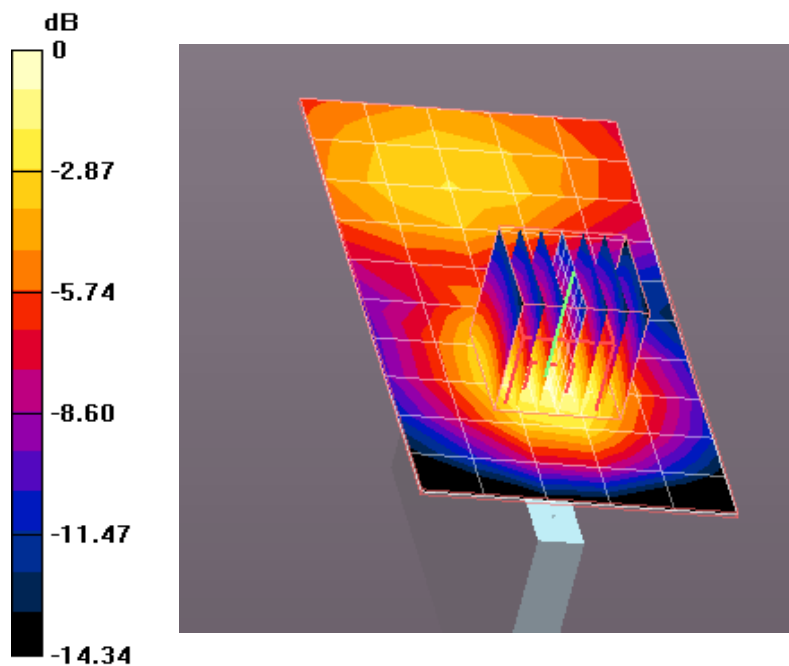



**Plot 9**

Date/Time: 10/5/2011 1:24:58 PM, Date/Time: 10/5/2011 1:28:19 PM

Test Laboratory: Cetecom Inc., SAR 3 Lab

**DUT: RDR61CW; Serial: MEID FED12**

Communication System: CDMA2000 RC3; Frequency: 1880 MHz

Medium parameters used:  $f = 1880$  MHz;  $\sigma = 1.471$  mho/m;  $\epsilon_r = 52.96$ ;  $\rho = 1000$  kg/m<sup>3</sup>

Phantom section: Flat Section

Measurement Standard: DASYS (IEEE/IEC/ANSI C63.19-2007)

DASY52 Configuration:

- Probe: ES3DV3 - SN3261; ConvF(4.8, 4.8, 4.8); Calibrated: 5/30/2011
- Sensor-Surface: 3mm (Mechanical Surface Detection)
- Electronics: DAE4 Sn1266; Calibrated: 5/30/2011
- Phantom: ELI v5.0; Type: QDOVA002AA; Serial: TP:1124
- DASY52 52.6.2(482); SEMCAD X 14.4.5(3634)

**Flat-Section MSL 2/Right Side 10mm\_Mid Channel/Area Scan (11x6x1):** Measurement grid:

dx=15mm, dy=15mm

Maximum value of SAR (measured) = 0.225 mW/g

**Flat-Section MSL 2/Right Side 10mm\_Mid Channel/Zoom Scan (7x7x7)/Cube 0:** Measurement grid:

dx=5mm, dy=5mm, dz=5mm

Reference Value = 12.801 V/m; Power Drift = 0.06 dB

Peak SAR (extrapolated) = 0.348 W/kg

**SAR(1 g) = 0.208 mW/g; SAR(10 g) = 0.121 mW/g**

Maximum value of SAR (measured) = 0.255 mW/g

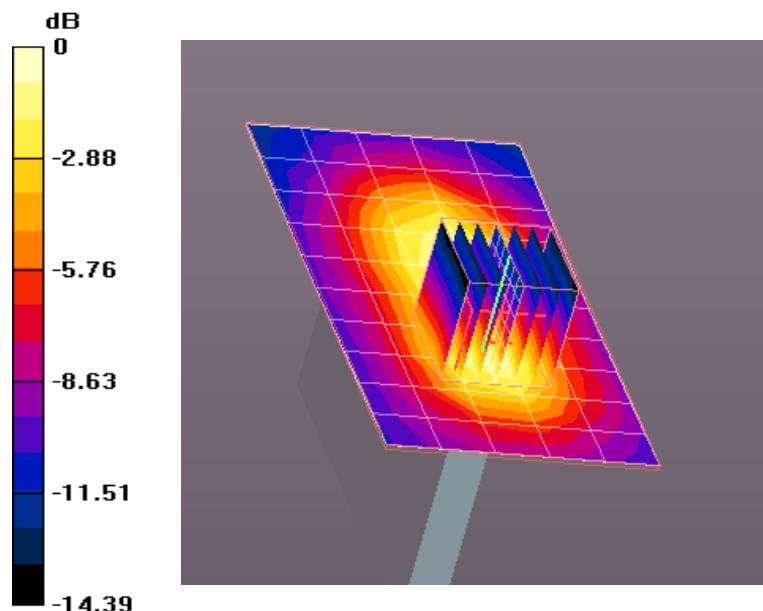

0 dB = 0.260mW/g

**Plot 10**

Date/Time: 10/5/2011 1:47:17 PM, Date/Time: 10/5/2011 1:51:23 PM

Test Laboratory: Cetecom Inc., SAR 3 Lab

**DUT: RDR61CW; Serial: MEID FED12**

Communication System: CDMA2000 RC3; Frequency: 1880 MHz

Medium parameters used:  $f = 1880$  MHz;  $\sigma = 1.471$  mho/m;  $\epsilon_r = 52.96$ ;  $\rho = 1000$  kg/m<sup>3</sup>

Phantom section: Flat Section

Measurement Standard: DASYS (IEEE/IEC/ANSI C63.19-2007)

DASY52 Configuration:

- Probe: ES3DV3 - SN3261; ConvF(4.8, 4.8, 4.8); Calibrated: 5/30/2011
- Sensor-Surface: 3mm (Mechanical Surface Detection)
- Electronics: DAE4 Sn1266; Calibrated: 5/30/2011
- Phantom: ELI v5.0; Type: QDOVA002AA; Serial: TP:1124
- DASY52 52.6.2(482); SEMCAD X 14.4.5(3634)

**Flat-Section MSL/Bottom Edge 10mm\_Mid Channel/Area Scan (6x7x1):** Measurement grid:

dx=15mm, dy=15mm

Maximum value of SAR (measured) = 0.738 mW/g

**Flat-Section MSL/Bottom Edge 10mm\_Mid Channel/Zoom Scan (7x7x7)/Cube 0:** Measurement grid:

dx=5mm, dy=5mm, dz=5mm

Reference Value = 25.077 V/m; Power Drift = -0.20 dB

Peak SAR (extrapolated) = 1.130 W/kg

**SAR(1 g) = 0.687 mW/g; SAR(10 g) = 0.389 mW/g**

Maximum value of SAR (measured) = 0.842 mW/g

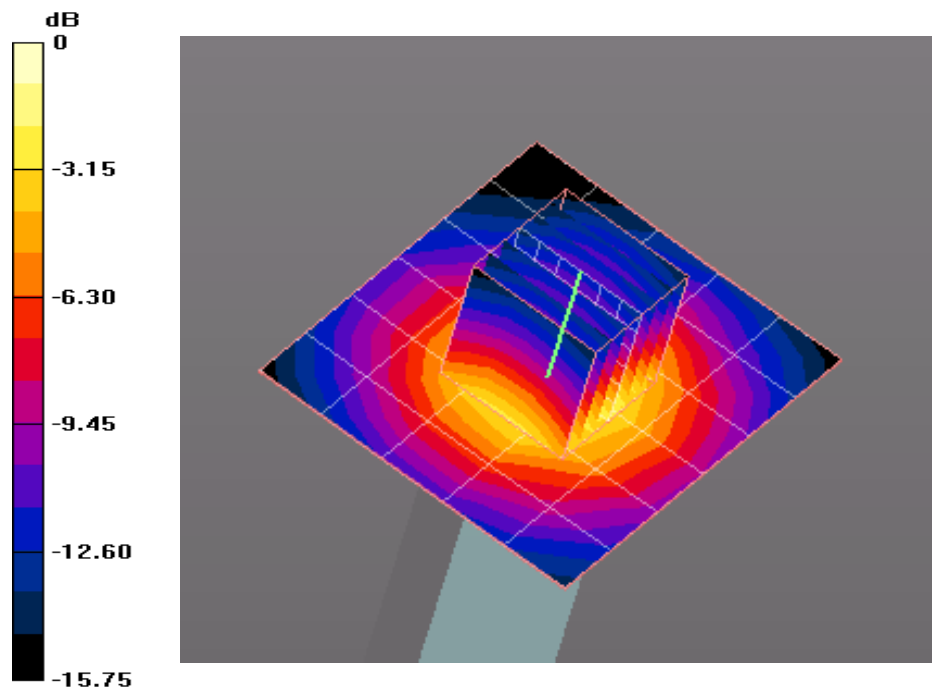

0 dB = 0.840mW/g

**Plot 11**

Date/Time: 10/5/2011 11:56:11 AM, Date/Time: 10/5/2011 12:00:04 PM

Test Laboratory: Cetecom Inc., SAR 3 Lab

**DUT: RDR61CW; Serial: MEID FED12**

Communication System: CDMA2000 RC3; Frequency: 1851.25 MHz

Medium parameters used:  $f = 1851.25$  MHz;  $\sigma = 1.448$  mho/m;  $\epsilon_r = 53.44$ ;  $\rho = 1000$  kg/m<sup>3</sup>

Phantom section: Flat Section

Measurement Standard: DASYS (IEEE/IEC/ANSI C63.19-2007)

DASY52 Configuration:

- Probe: ES3DV3 - SN3261; ConvF(4.8, 4.8, 4.8); Calibrated: 5/30/2011
- Sensor-Surface: 3mm (Mechanical Surface Detection)
- Electronics: DAE4 Sn1266; Calibrated: 5/30/2011
- Phantom: ELI v5.0; Type: QDOVA002AA; Serial: TP:1124
- DASY52 52.6.2(482); SEMCAD X 14.4.5(3634)

**Flat-Section MSL/Back 10mm\_Low Channel/Area Scan (11x7x1):** Measurement grid: dx=15mm, dy=15mm

Maximum value of SAR (measured) = 1.339 mW/g

**Flat-Section MSL/Back 10mm\_Low Channel/Zoom Scan (7x7x7)/Cube 0:** Measurement grid: dx=5mm, dy=5mm, dz=5mm

Reference Value = 12.152 V/m; Power Drift = 0.03 dB

Peak SAR (extrapolated) = 1.848 W/kg

**SAR(1 g) = 1.14 mW/g; SAR(10 g) = 0.694 mW/g**

Maximum value of SAR (measured) = 1.372 mW/g

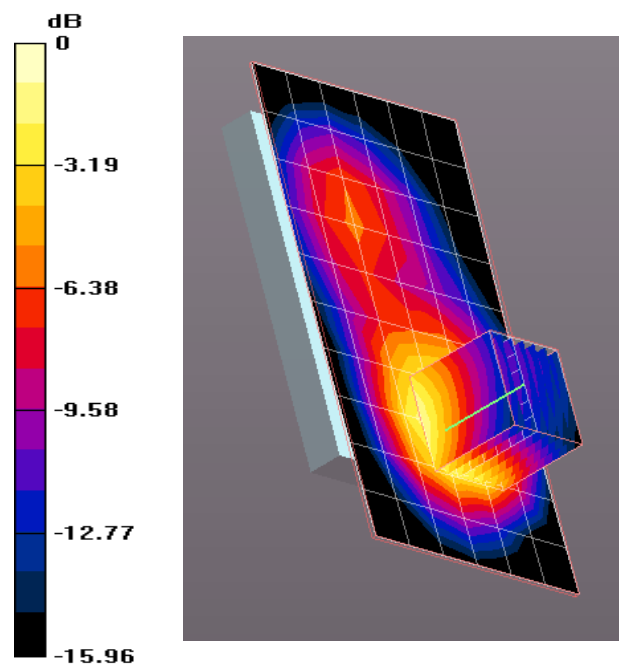

0 dB = 1.370mW/g

### Plot 12

Date/Time: 10/5/2011 12:14:01 PM, Date/Time: 10/5/2011 12:17:54 PM

Test Laboratory: Cetecom Inc., SAR 3 Lab

**DUT: RDR61CW; Serial: MEID FED12**

Communication System: CDMA2000 RC3; Frequency: 1908.75 MHz

Medium parameters used:  $f = 1908.75$  MHz;  $\sigma = 1.461$  mho/m;  $\epsilon_r = 52.66$ ;  $\rho = 1000$  kg/m<sup>3</sup>

Phantom section: Flat Section

Measurement Standard: DASYS (IEEE/IEC/ANSI C63.19-2007)

DASY52 Configuration:

- Probe: ES3DV3 - SN3261; ConvF(4.8, 4.8, 4.8); Calibrated: 5/30/2011
- Sensor-Surface: 3mm (Mechanical Surface Detection)
- Electronics: DAE4 Sn1266; Calibrated: 5/30/2011
- Phantom: ELI v5.0; Type: QDOVA002AA; Serial: TP:1124
- DASY52 52.6.2(482); SEMCAD X 14.4.5(3634)

**Flat-Section MSL/Back 10mm\_High Channel/Area Scan (11x7x1):** Measurement grid: dx=15mm, dy=15mm

Maximum value of SAR (measured) = 0.902 mW/g

**Flat-Section MSL/Back 10mm\_High Channel/Zoom Scan (7x7x7)/Cube 0:** Measurement grid: dx=5mm, dy=5mm, dz=5mm

Reference Value = 10.540 V/m; Power Drift = -0.11 dB

Peak SAR (extrapolated) = 1.334 W/kg

**SAR(1 g) = 0.791 mW/g; SAR(10 g) = 0.477 mW/g**

Maximum value of SAR (measured) = 0.946 mW/g

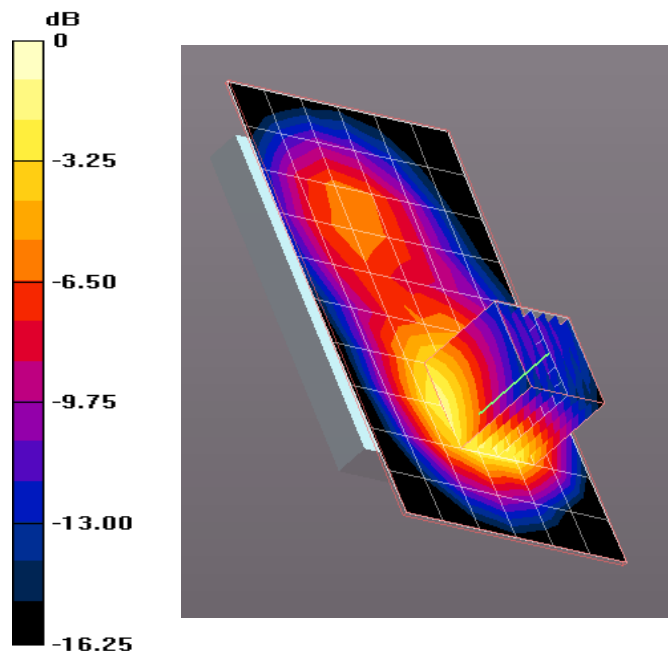

0 dB = 0.950mW/g

### Plot 13

Date/Time: 10/4/2011 1:13:10 PM, Date/Time: 10/4/2011 1:19:32 PM

Test Laboratory: Cetecom Inc. SAR 1 Lab

**DUT: Dipole 835 MHz - D835V2 - SN4d113; Type: D835V2; Serial: D835V2 - SN:4d113**

Communication System: CW; Frequency: 835 MHz  
Medium parameters used:  $f = 835$  MHz;  $\sigma = 1.014$  mho/m;  $\epsilon_r = 55.9$ ;  $\rho = 1000$  kg/m<sup>3</sup>  
Phantom section: Flat Section  
Measurement Standard: DASYS (IEEE/IEC/ANSI C63.19-2007)

DASY52 Configuration:

- Probe: ES3DV3 - SN3244; ConvF(6.05, 6.05, 6.05); Calibrated: 10/13/2010
- Sensor-Surface: 3mm (Mechanical Surface Detection), Sensor-Surface: 4mm (Mechanical Surface Detection)
- Electronics: DAE4 Sn1233; Calibrated: 10/13/2010
- Phantom: ELI 4.0; Type: QDOVA001BA; Serial: xxxxx
- DASY52 52.6.2(482); SEMCAD X 14.4.5(3634)

**System Performance Check at Frequencies below 1 GHz/d=15mm, Pin=1W, dist=3.0mm (ES-Probe)/Area Scan (7x9x1):** Measurement grid: dx=15mm, dy=15mm  
Maximum value of SAR (measured) = 11.457 mW/g

**System Performance Check at Frequencies below 1 GHz/d=15mm, Pin=1W, dist=3.0mm (ES-Probe)/Zoom Scan (7x7x7) (7x7x7)/Cube 0:** Measurement grid: dx=5mm, dy=5mm, dz=5mm  
Reference Value = 114.9 V/m; Power Drift = 0.08 dB  
Peak SAR (extrapolated) = 16.073 W/kg  
**SAR(1 g) = 10.9 mW/g; SAR(10 g) = 7.17 mW/g**  
Maximum value of SAR (measured) = 11.800 mW/g

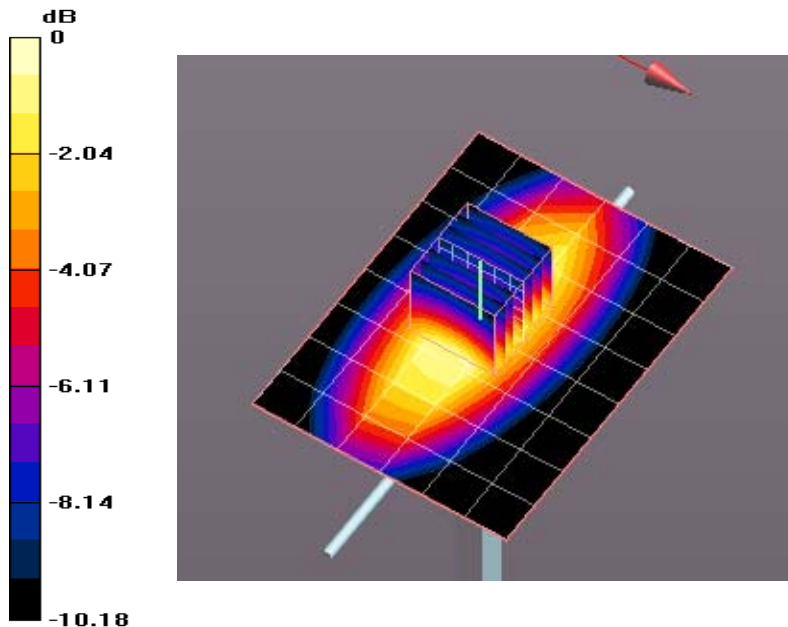

0 dB = 11.800mW/g

### Plot 14

Date/Time: 10/4/2011 4:12:00 PM, Date/Time: 10/4/2011 4:18:21 PM

Test Laboratory: Cetecom Inc., SAR 3 Lab

**DUT: Dipole 1900 MHz D1900V2; Type: D1900V2; Serial: D1900V2 - SN:5d135**

Communication System: CW; Frequency: 1900 MHz

Medium parameters used:  $f = 1900$  MHz;  $\sigma = 1.467$  mho/m;  $\epsilon_r = 52.72$ ;  $\rho = 1000$  kg/m<sup>3</sup>

Phantom section: Flat Section

Measurement Standard: DASYS (IEEE/IEC/ANSI C63.19-2007)

DASY52 Configuration:

- Probe: ES3DV3 - SN3261; ConvF(4.57, 4.57, 4.57); Calibrated: 8/18/2011
- Sensor-Surface: 3mm (Mechanical Surface Detection), Sensor-Surface: 4mm (Mechanical Surface Detection)
- Electronics: DAE4 Sn1266; Calibrated: 5/30/2011
- Phantom: ELI v5.0; Type: QDOVA002AA; Serial: TP:1124
- DASY52 52.6.2(482); SEMCAD X 14.4.5(3634)

**System Performance Check at Frequencies below 1 GHz/d=10mm, Pin=1W, dist=3.0mm (ES-Probe)/Area Scan (7x9x1):** Measurement grid: dx=15mm, dy=15mm

Maximum value of SAR (measured) = 38.958 mW/g

**System Performance Check at Frequencies below 1 GHz/d=10mm, Pin=1W, dist=3.0mm (ES-Probe)/Zoom Scan (7x7x7) (7x7x7)/Cube 0:** Measurement grid: dx=5mm, dy=5mm, dz=5mm

Reference Value = 191.1 V/m; Power Drift = 0.05 dB

Peak SAR (extrapolated) = 72.394 W/kg

**SAR(1 g) = 39.8 mW/g; SAR(10 g) = 20.9 mW/g**

Maximum value of SAR (measured) = 44.857 mW/g

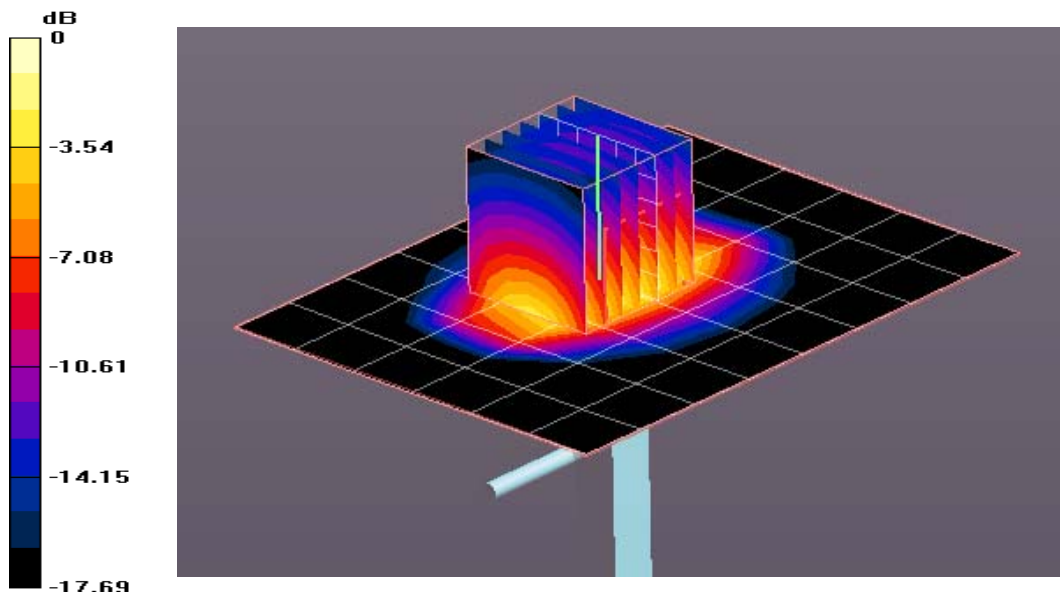

0 dB = 44.860mW/g