



DFS Test Report

FCC 15.407 & RSS-210, Issue 7

For

RDU71CW, RDE71UW, RDV71UW and RDY71UW
Blackberry Handheld

FCC: L6ARDU70CW
IC: 2503A-RDU70CW

TEST REPORT #: EMC_CETE4-013-11001_DFS_FCC_Rev1
DATE: 2011-06-22



FCC listed:
A2LA accredited

IC recognized #
3462B

CETECOM Inc.

411 Dixon Landing Road • Milpitas, CA 95035 • U.S.A.

Phone: + 1 (408) 586 6200 • Fax: + 1 (408) 586 6299 • E-mail: info@cetecomusa.com • <http://www.cetecom.com>

CETECOM Inc. is a Delaware Corporation with Corporation number: 2113686

Board of Directors: Dr. Harald Ansorge, Dr. Klaus Matkey, Hans Peter May

TABLE OF CONTENTS

1	ASSESSMENT	3
2	ADMINISTRATIVE DATA.....	4
2.1	IDENTIFICATION OF THE TESTING LABORATORY ISSUING THE EMC TEST REPORT	4
2.2	IDENTIFICATION OF THE CLIENT	4
2.3	IDENTIFICATION OF THE MANUFACTURER	4
3	EQUIPMENT UNDER TEST (EUT)	5
3.1	SPECIFICATION OF THE EQUIPMENT UNDER TEST	5
3.2	IDENTIFICATION OF THE EQUIPMENT UNDER TEST (EUT).....	5
4	SUBJECT OF INVESTIGATION.....	6
5	APPLICABILITY OF DFS REQUIREMENTS.....	7
6	RADAR TEST SIGNALS.....	7
6.1	PARAMETERS OF SHORT PULSE RADAR TEST WAVEFORMS (FCC 06-96, SECTION 6.1).....	7
6.2	PARAMETERS OF LONG PULSE RADAR TEST WAVEFORMS (FCC 06-96, SECTION 6.2)	7
6.3	PARAMETERS OF FREQUENCY HOPPING RADAR TEST WAVEFORMS (FCC 06-96, SECTION 6.3).....	7
7	CONDUCTED MEASUREMENTS	8
7.1	CHANNEL SHUTDOWN AND NON-OCCUPANCY PERIOD	9
7.1.1	<i>Limits</i>	9
7.1.2	<i>Results</i>	9
8	BLOCK DIAGRAM	12
9	TEST EQUIPMENT AND ANCILLARIES USED FOR TESTS.....	13
10	TEST SET-UP PICTURES	13
11	REPORT HISTORY.....	14



1 Assessment

The following is in compliance with the DFS criteria specified in FCC rules Part 15.407 of the Code of Federal Regulations.

Company	Description	Model #
Research In Motion	Blackberry Handheld	RDU71CW, RDE71UW, RDV71UW and RDY71UW

This report is reviewed by:

2011-06-22	Compliance	Sajay Jose (Lab Manager)	
Date	Section	Name	Signature

This report is prepared by:

2011-06-22	Compliance	David Lang (EMC Engineer)	
Date	Section	Name	Signature

The test results of this test report relate exclusively to the test item specified in Identification of the Equipment under Test-section 3. CETECOM Inc. USA does not assume responsibility for any conclusions and generalizations drawn from the test results with regard to other specimens or samples of the type of the equipment represented by the test item. The test report may only be reproduced or published in full. Reproduction or publication of extracts from the report requires the prior written approval of the CETECOM Inc USA.
 This report replaces any previously issued reports.

2 Administrative Data

2.1 Identification of the Testing Laboratory Issuing the EMC Test Report

Company Name:	CETECOM Inc.
Department:	Compliance
Address:	411 Dixon Landing Road Milpitas, CA 95035 U.S.A.
Telephone:	+1 (408) 586 6200
Fax:	+1 (408) 586 6299
Responsible Test Lab Manager:	Heiko Strehlow
Responsible Project Leader:	David Lang

2.2 Identification of the Client

Applicant's Name:	Research In Motion
Street Address:	440 Philip Street
City/Zip Code	Waterloo
Country	Canada
Contact Person:	Masud Attayi
Phone No.	1-519 888 7465 ext. 72442
Fax:	1-519 746 0189
e-mail:	Mattayi@rim.com

2.3 Identification of the Manufacturer

Manufacturer's Name:	Same as applicant
Manufacturers Address:	
City/Zip Code	
Country	

3 Equipment Under Test (EUT)

3.1 Specification of the Equipment under Test

Marketing Name:	BlackBerry Smartphone
Model No:	RDU71CW Variants: RDE71UW, RDV71UW and RDY71UW
Product Type:	Blackberry Handheld
Hardware Revision :	RDU71CW: CER: 32268-001 Rev3 Variants: RDE71UW: CER-21958-001 Rev2 RDV71UW: CER-39235-001 Rev2 RDY71UW: CER-21958-002 Rev2
Software Revision :	V6.1.0.46, Platform: 5.0.0.123, B421
FCC ID:	L6ARDU70CW Variants: L6ARDE70UW; L6ARDV70UW; L6ARDY70UW
IC No.:	2503A-RDU70CW Variants: 2503A-RDE70UW; 2503A-RDV70UW; 2503A-RDY70UW
Frequency:	5150-5250MHz, 5250 – 5350 MHz, 5470 – 5725 MHz, 5725 – 5825 MHz
Type(s) of Modulation:	OFDM
Number of channels:	802.11b/g/n ch1-14, 802.11a/n ch183-196,7-165
Antenna Type:	Dual-band Inverted-F antenna
Equipment Classification:	<input type="checkbox"/> Fixed <input type="checkbox"/> Vehicular <input checked="" type="checkbox"/> Portable <input type="checkbox"/> Module
Power Supply:	3.7V DC Lithium Ion Rechargeable Battery

3.2 Identification of the Equipment Under Test (EUT)

EUT #	Model	HW Version	SW Version	Serial Number
1	RDU71CW	CER-32268-001 REV3	V6.1.0.46, Platform: 5.0.0.123, B421	MEID-HEX: A000002587BFF0

4 Subject Of Investigation

The difference between the 4 named products is as follows:

RDU71CW supports DB CDMA2000/1xEVDO and UMTS FDD 1,8.

RDE71UW supports UMTS FDD 1,2,5/6.

RDV71UW supports UMTS FDD 1,4,8.

RDY71UW also supports UMTS FDD 1,2,5/6.

The manufacturer declares that the WLAN radios of all named products are identical. Therefore all tests mentioned in this report were performed on the RDU71CW.

5 Applicability of DFS requirements

Requirement	Operational mode		
	Master	Slave Without Radar Detection	Slave With Radar Detection
<i>Channel Availability Check</i>	Yes	Not required	Not required
<i>UNII Detection Bandwidth</i>	Yes	Not required	Yes
<i>In-Service Monitoring</i>	Yes	Not required	Yes
<i>Channel Shutdown</i>	Yes	Yes	Yes
<i>Non-Occupancy Period</i>	Yes	Not required	Yes
<i>Uniform Spreading</i>	Yes	Not required	Not required

6 Radar test signals

6.1 Parameters of Short Pulse Radar Test Waveforms (FCC 06-96, Section 6.1)

Radar Type	Pulse Width (µsec)	PRI (µs)	Number of Pulses	Minimum Percentage of Successful Detection	Minimum Number of Trials
1	1	1428	18	60%	30
2	1-5	150-230	23-29	60%	30
3	6-10	200-500	16-18	60%	30
4	11-20	200-500	12-16	60%	30
Aggregate (Radar Types 1-4)				80%	120

6.2 Parameters of Long Pulse Radar Test Waveforms (FCC 06-96, Section 6.2)

Radar Type	Pulse Width (µsec)	Chirp Width (MHz)	PRI (µs)	Number of Pulses per Burst	Number of Bursts	Minimum Percentage of Successful Detection	Minimum Number of Trials
5	50-100	5-20	1000-2000	1-3	8-20	80%	30

6.3 Parameters of Frequency Hopping Radar Test Waveforms (FCC 06-96, Section 6.3)

Radar Type	Pulse Width (µsec)	PRI (µsec)	Pulses per Hop	Hopping Rate (kHz)	Hopping Sequence Length (msec)	Minimum Percentage of Successful Detection	Minimum Number of Trials
6	1	333	9	0.333	300	70%	30

7 Conducted Measurements

Conducted measurements were performed according to FCC 06-96. The measurements were performed on channel 60 (5300 MHz) of the DFS bands. 40 MHz bandwidth was used for tests. The DFS threshold used was -63 dBm. Radar Type 1 of the Short Pulse Test Waveforms was used for tests (see 5.1).

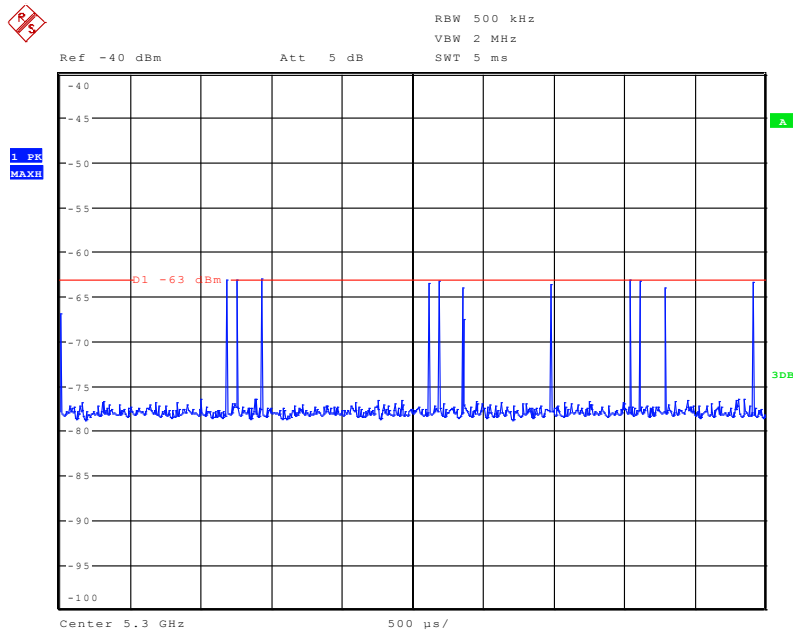

Date: 18.JUN.2011 13:30:32

7.1 Channel Shutdown and Non-Occupancy Period

7.1.1 Limits

The *Channel Move Time* shall not exceed 10 seconds.

The *Channel Closing Transmission Time* shall not exceed 200ms.

The *Non-Occupancy Period* shall not be less than 30 minutes.

7.1.2 Results

Channel Move Time = 453.75ms

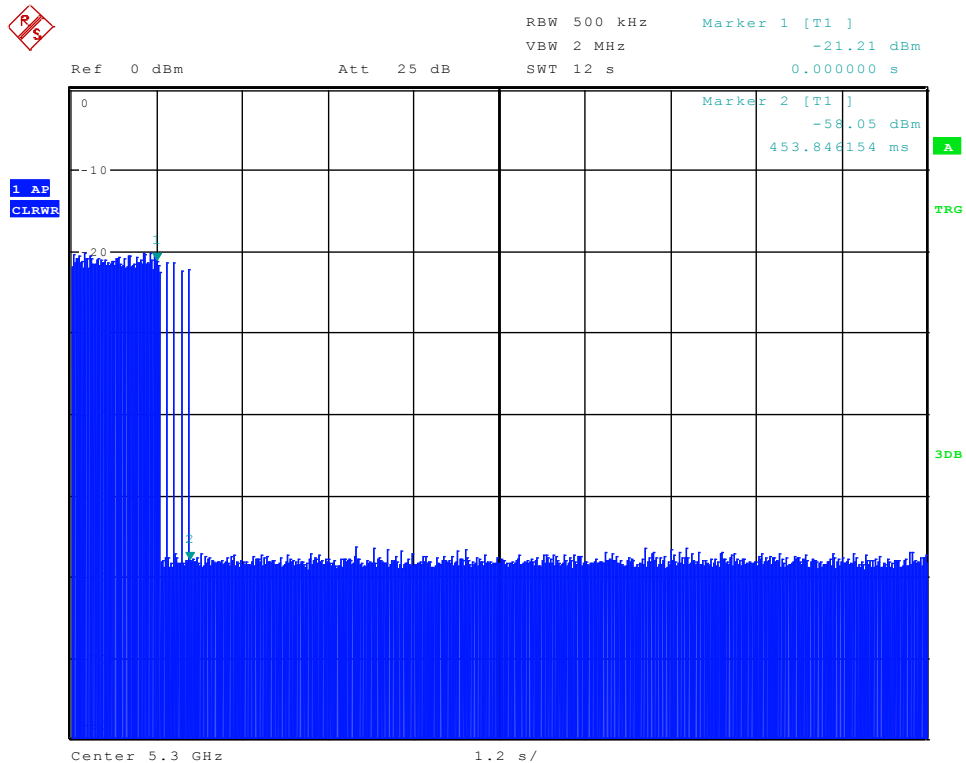

Channel Closing Transmission Time = 26ms.

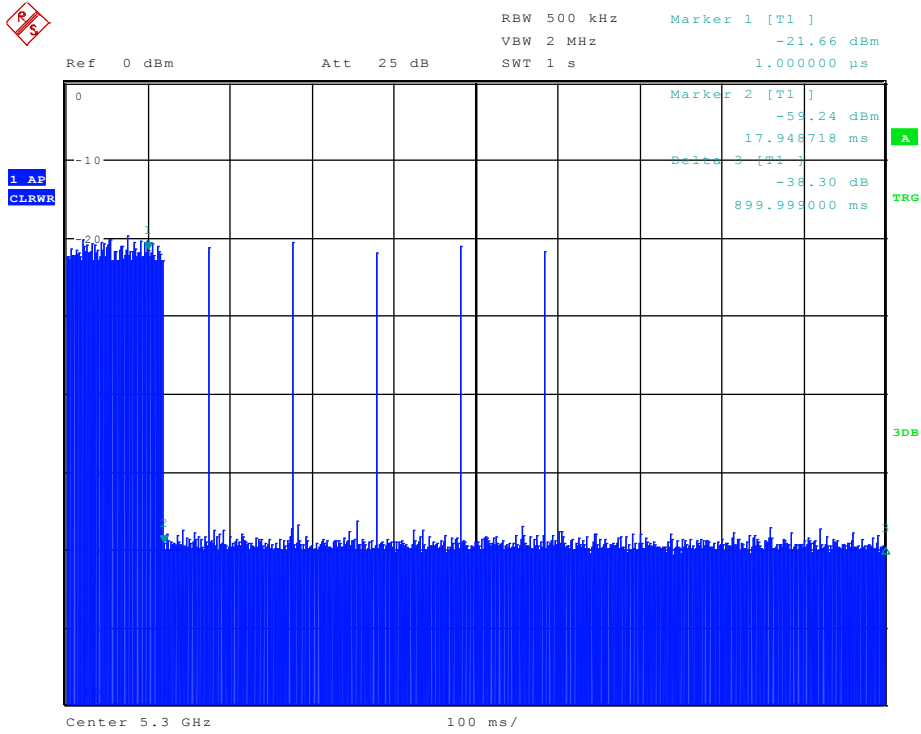

Date: 18.JUN.2011 17:00:02



Non-Occupancy Period ≥ 30 min.

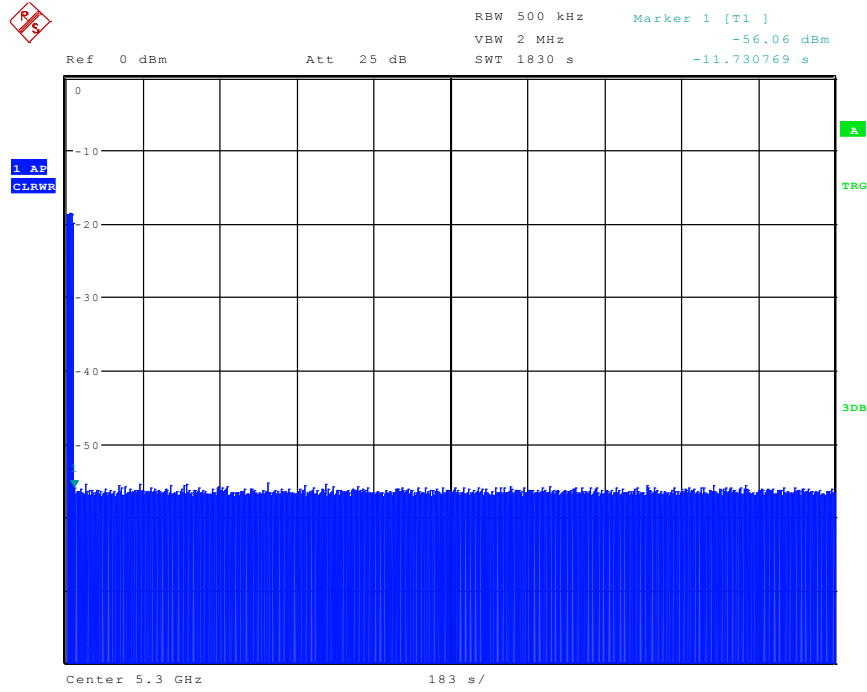

Date: 18.JUN.2011 17:44:36

8 Block Diagram

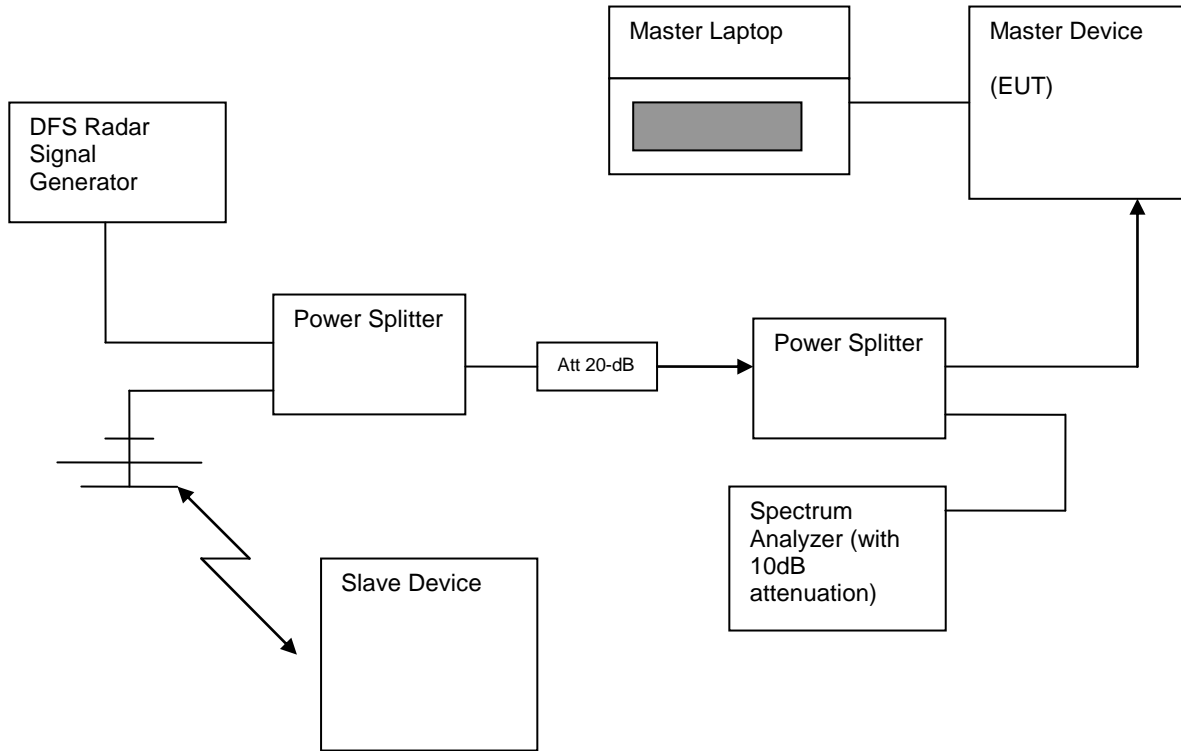

9 TEST EQUIPMENT AND ANCILLARIES USED FOR TESTS

No	Instrument/Ancillary	Type	Manufacturer	Serial No.	Cal Date
E149	Spectrum Analyzer	FSU	Rohde & Schwarz	200302	July 2011
E171	ASCOR Upconverter	7206	National Instruments	N/A	N/A
E153	DFS Waveform Generator / PXI 5421 Card	NI PXI-1042	National Instruments	E965F1	July 2010
E152	DFS Signal Generator / PXI 5610 Card	NI PXI 1042	National Instruments	E93740	July 2010

10 TEST SET-UP PICTURES

See document #EMC_CETE4-013-11001_DFS_FCC_PIC



11 Report History

Date	Report Name	Changes to report	Report prepared by
2011-06-22	EMC_CETE4-013-11001_DFS_FCC	First Version	D Lang
2011-06-22	EMC_CETE4-013-11001_DFS_FCC_Rev1	Marketing name changed, FCC/ID added, Subject of investigation statement changed	D Lang