

Sheet	Ref.
TOP	
RF_ANT	2XX
AFE_TX	3XX
WB_AFE	4XX
WB_AFE2	5XX
A=GPS	6XX
IO_INTERF	8XX
POWER	9XX
POWER2	10XX
SIM/PROX	11XX
BT_WLAN	12XX
TAVOR_GPIO	13XX
TAVOR_MEM	14XX
TAVOR_SERV	15XX
IO_INTERF2	16XX
TAVOR_POW	17XX
KEYPAD 1	18XX
KEYPAD 2	19XX

RESEARCH IN MOTION CONFIDENTIAL

HIERARCHICAL BLOCK	COPYRIGHT 2010 RESEARCH IN MOTION LIMITED 295 PHILIP ST. WATERLOO, ONTARIO CANADA
DRAWN BY F10r1da PDC	PHONE (519) 888-7465 FAX (519) 888-6986
RWD CHECK F10r1da PDC	TITLE R011 Main PCB Schematic
MFG CHECK UNKNOWN	Uses PCB-29964-006
EDITED BY: maflones	SIZE DRAWING No. SCH-30365-006
LAST EDIT: 2010/04/16 09:11:18	REV A SHEET 1 of 19

RF_ANT

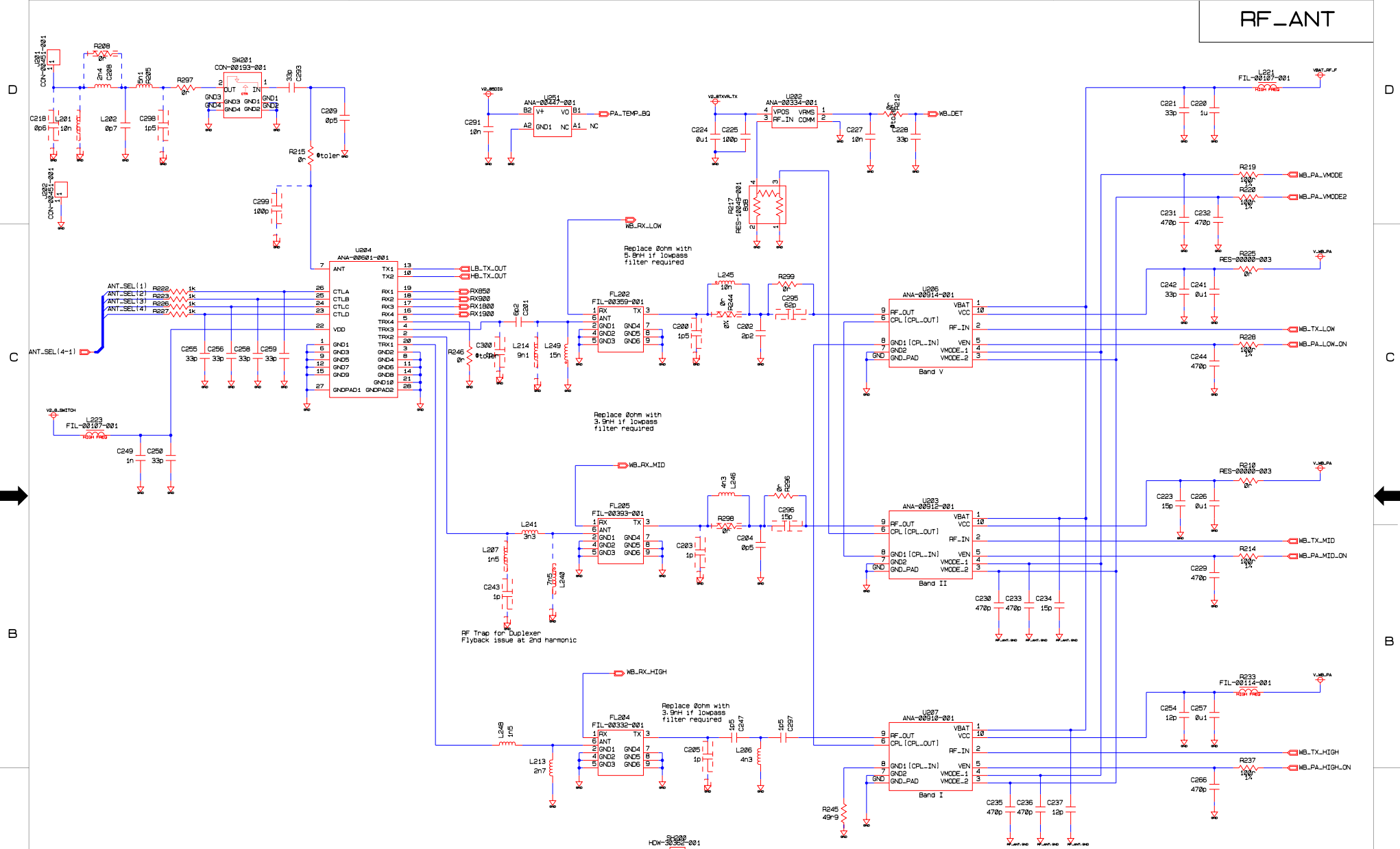

RESEARCH IN MOTION CONFIDENTIAL

HIERARCHICAL_BLOCK	COPYRIGHT 2010 RESEARCH IN MOTION LIMITED 295 PHILLIP ST. WATERLOO, ONTARIO CANADA
DRAWN BY	PHONE (519) 888-7465, FAX (519) 888-6806
RMD CHECK	TITLE
MFG CHECK	R011 Main PCB Schematic
EDITED BY:	Uses PCB-29964-006
LAST EDIT:	SIZE
2010/04/16 08:11:18	C DRAWING No. SCH-30365-006
	REV A SHEET 2 of 19

AFE_TX

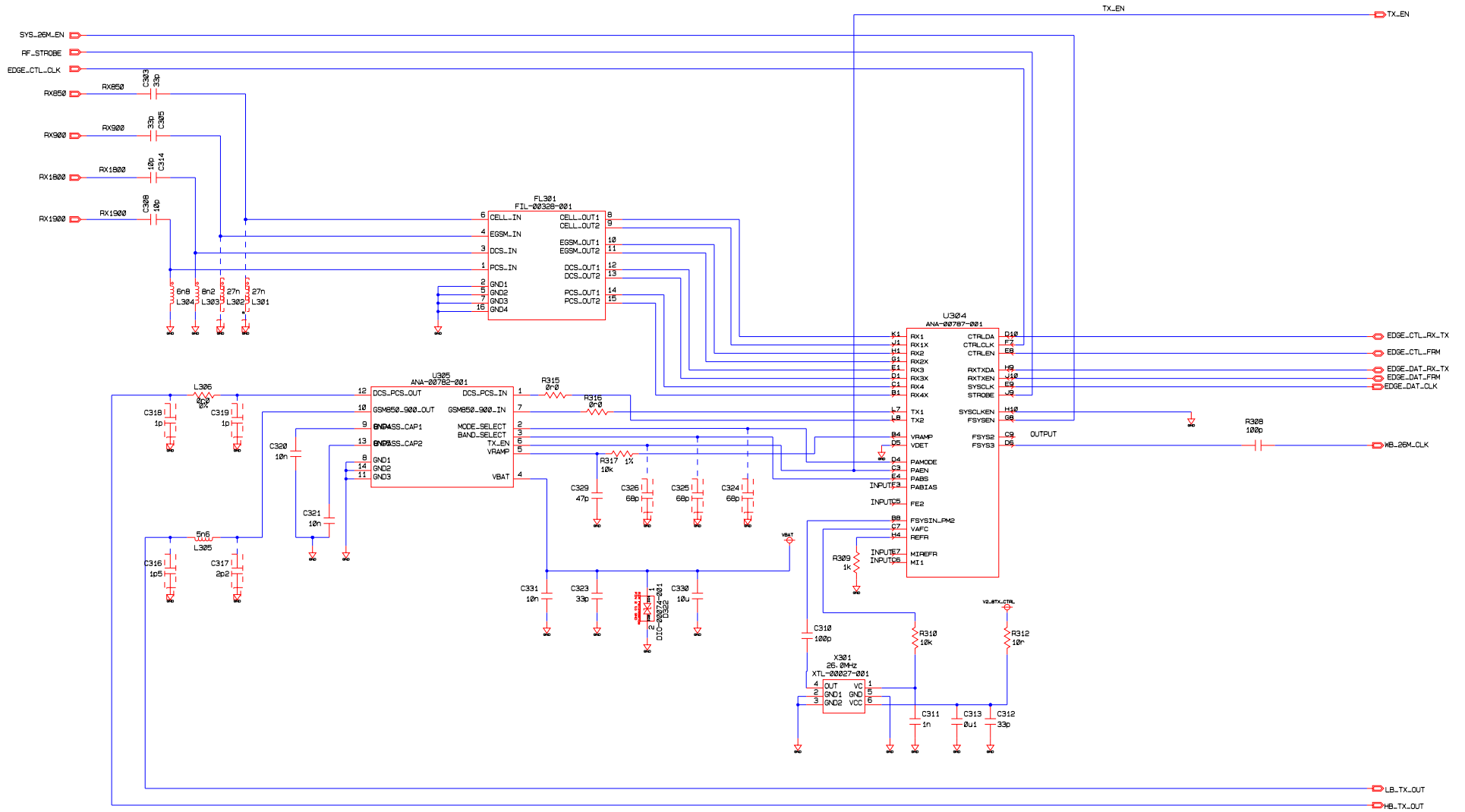

RESEARCH IN MOTION CONFIDENTIAL	
HIERARCHICAL BLOCK	COPYRIGHT 2010 RESEARCH IN MOTION LIMITED 295 PHILIP ST. WATERLOO, ONTARIO CANADA
DRAWN BY	PHONE (519) 888-7465 FAX (519) 888-6906
RD CHECK	TITLE
MFG CHECK	R011 Main PCB Schematic
EDITED BY:	Uses PCB-29964-006
LAST EDIT:	SIZE
2010/04/16 16:42:56	DRAWING No. SCH-30365-006
	REV A SHEET 3 of 19

WB_AFE

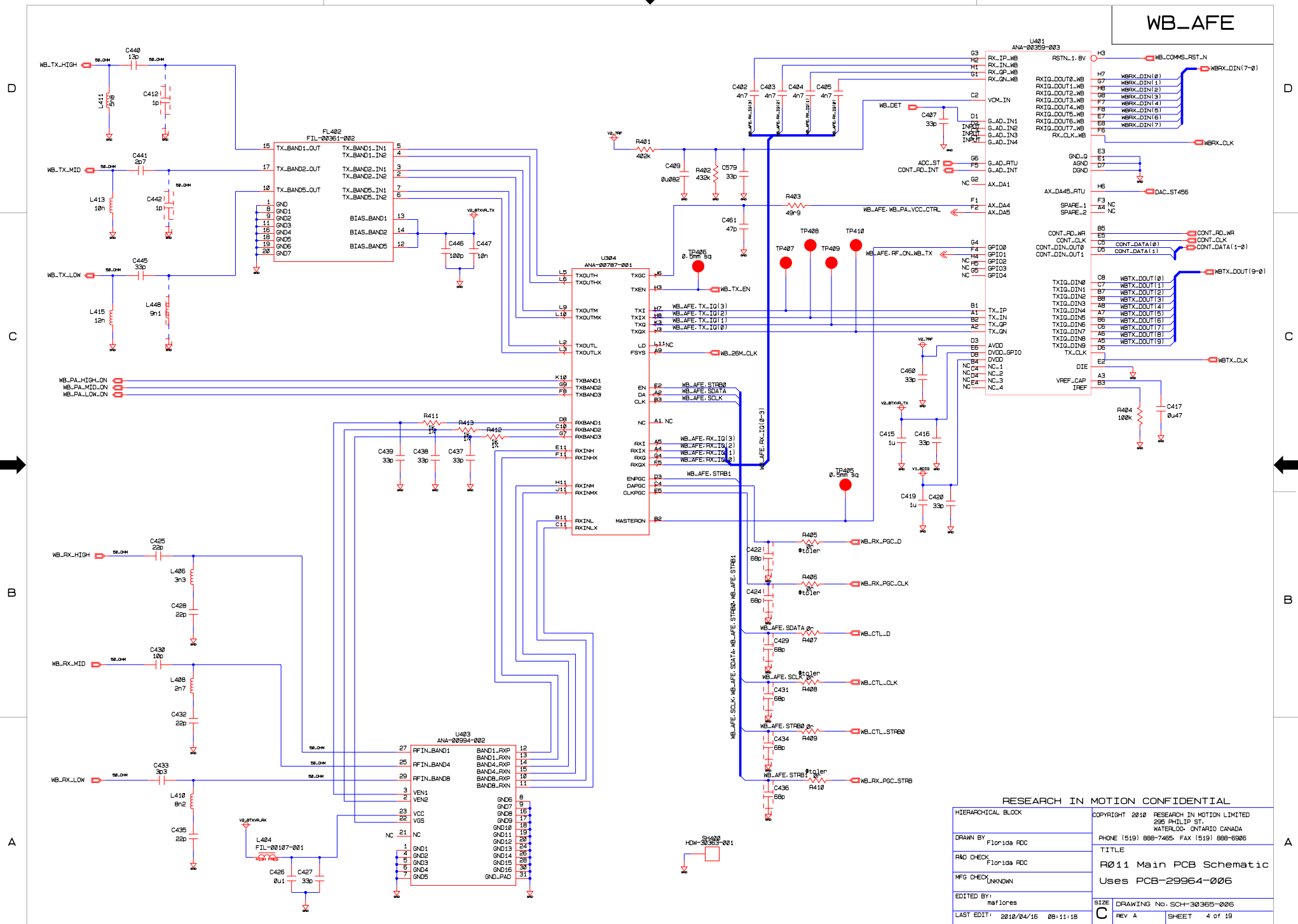

RESEARCH IN MOTION CONFIDENTIAL	
HIERARCHICAL BLOCK	COPYRIGHT 2010 RESEARCH IN MOTION LIMITED 295 PHILIP ST. WATERLOO, ONTARIO CANADA
DRAWN BY: F1or1da PDC	PHONE (519) 888-7465, FAX (519) 888-6986
RMD CHECK: F1or1da PDC	TITLE R011 Main PCB Schematic
MFG CHECK: UNKNOWN	Uses PCB-29964-006
EDITED BY: maf1ores	SIZE: DRAWING No. SCH-30365-006
LAST EDIT: 2010/04/16 09:11:18	REV A SHEET 4 of 19

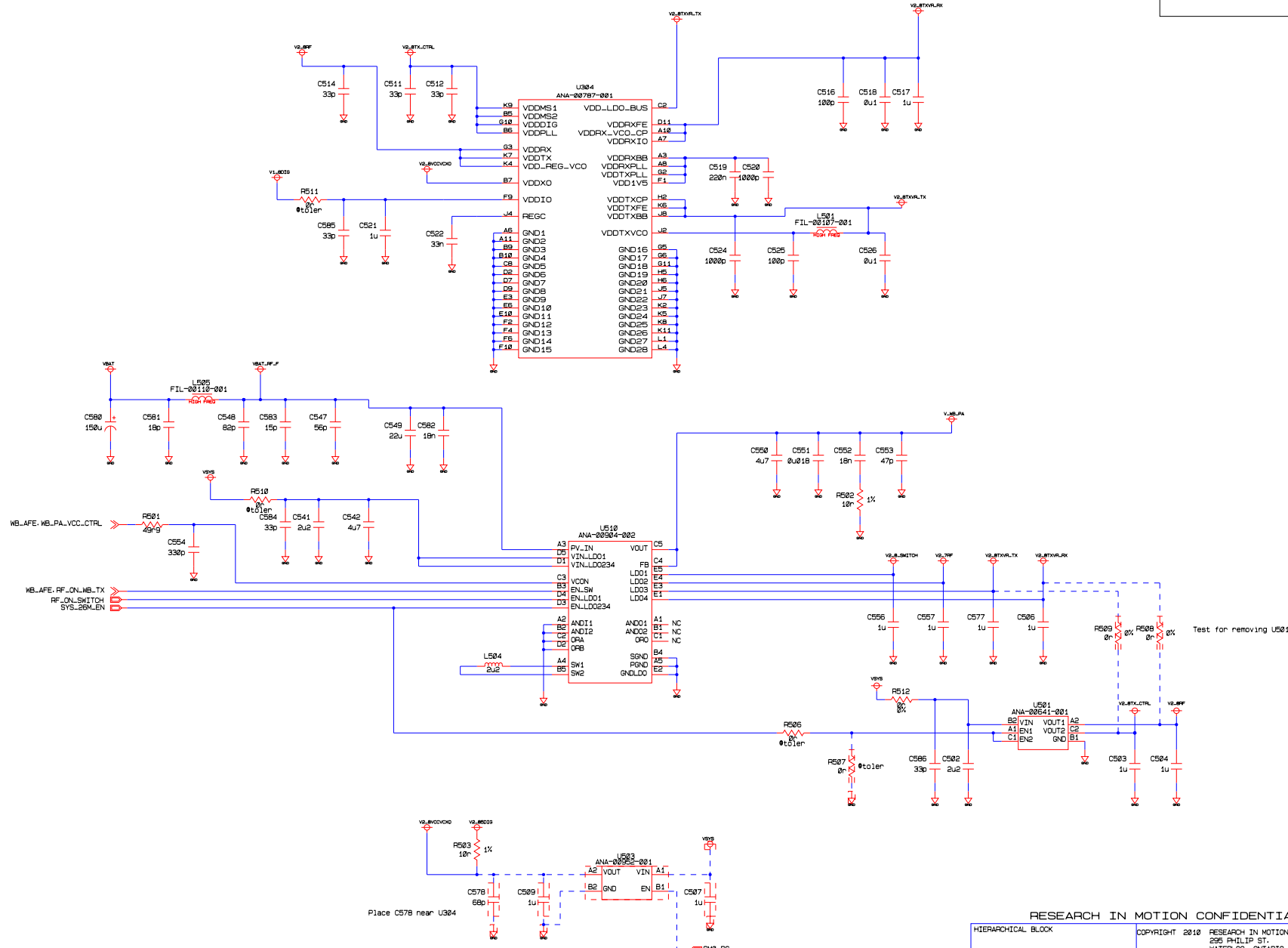

RESEARCH IN MOTION CONFIDENTIAL		
HIERARCHICAL BLOCK	COPYRIGHT 2010 RESEARCH IN MOTION LIMITED	
DRAWN BY	295 PHILIP ST.	
RND CHECK	WATERLOO, ONTARIO CANADA	
MFG CHECK	PHONE (519) 886-7465. FAX (519) 886-6906	
EDITED BY:	TITLE	
LAST EDIT:	R011 Main PCB Schematic	
2010/04/16 09:11:18	Uses PCB-29964-006	
SIZE	DRAWING No. SCH-30365-006	
REV A	SHEET	5 of 19

A-GPS

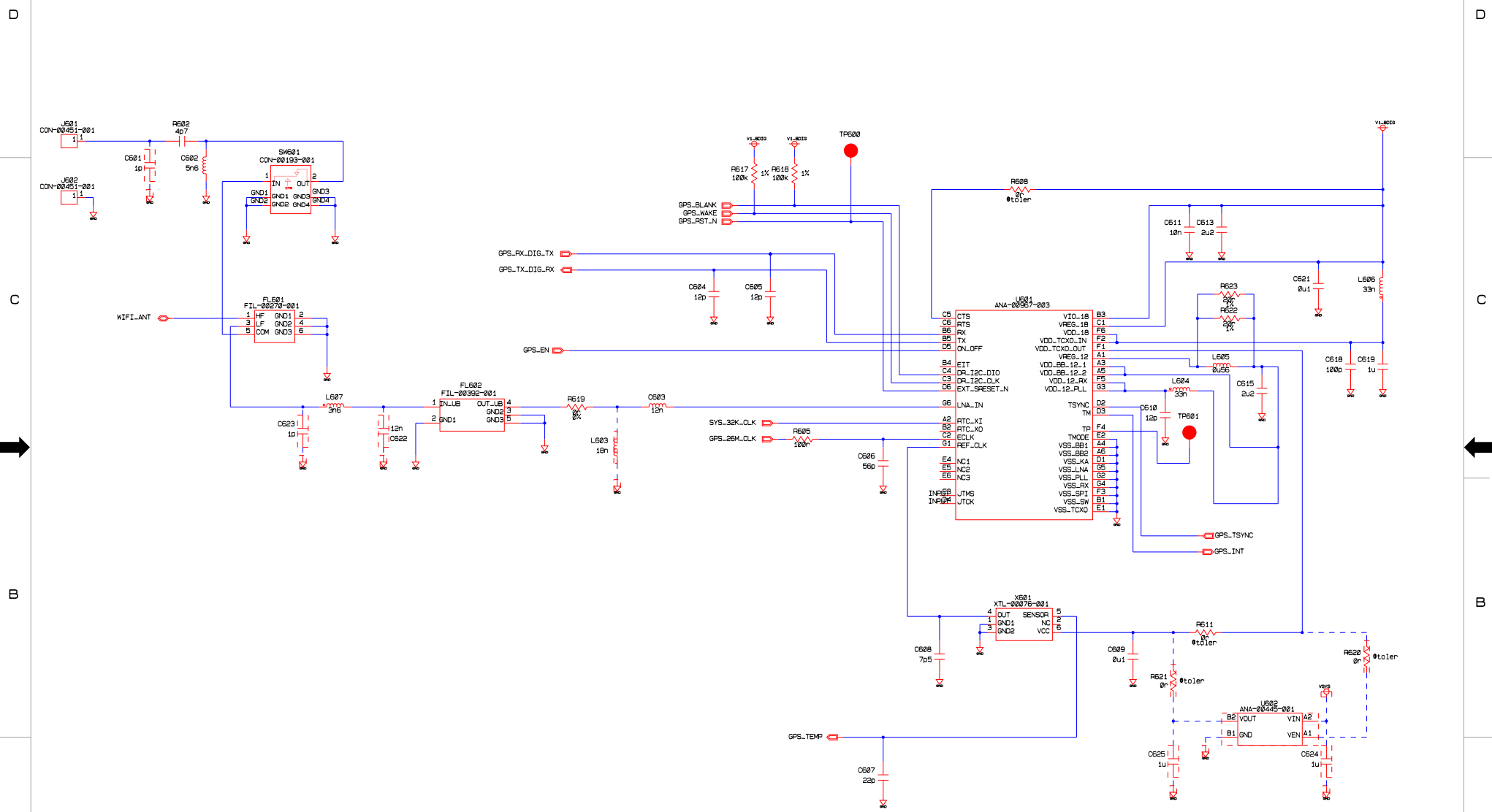

RESEARCH IN MOTION CONFIDENTIAL

HIERARCHICAL BLOCK	COPYRIGHT 2010 RESEARCH IN MOTION LIMITED 295 PHILIP ST. WATERLOO, ONTARIO CANADA PHONE (519) 889-7465 FAX (519) 889-6906
DRAWN BY F1or1da RDC	TITLE R011 Main PCB Schematic Uses PCB-29964-006
RWD CHECK F1or1da RDC	SIZE DRAWING No. SCH-30365-006
MFG CHECK UNKNOWN	REV A SHEET 6 of 19
EDITED BY: maf1ores	LAST EDIT: 2010/04/16 08:11:18

D
C
B
A

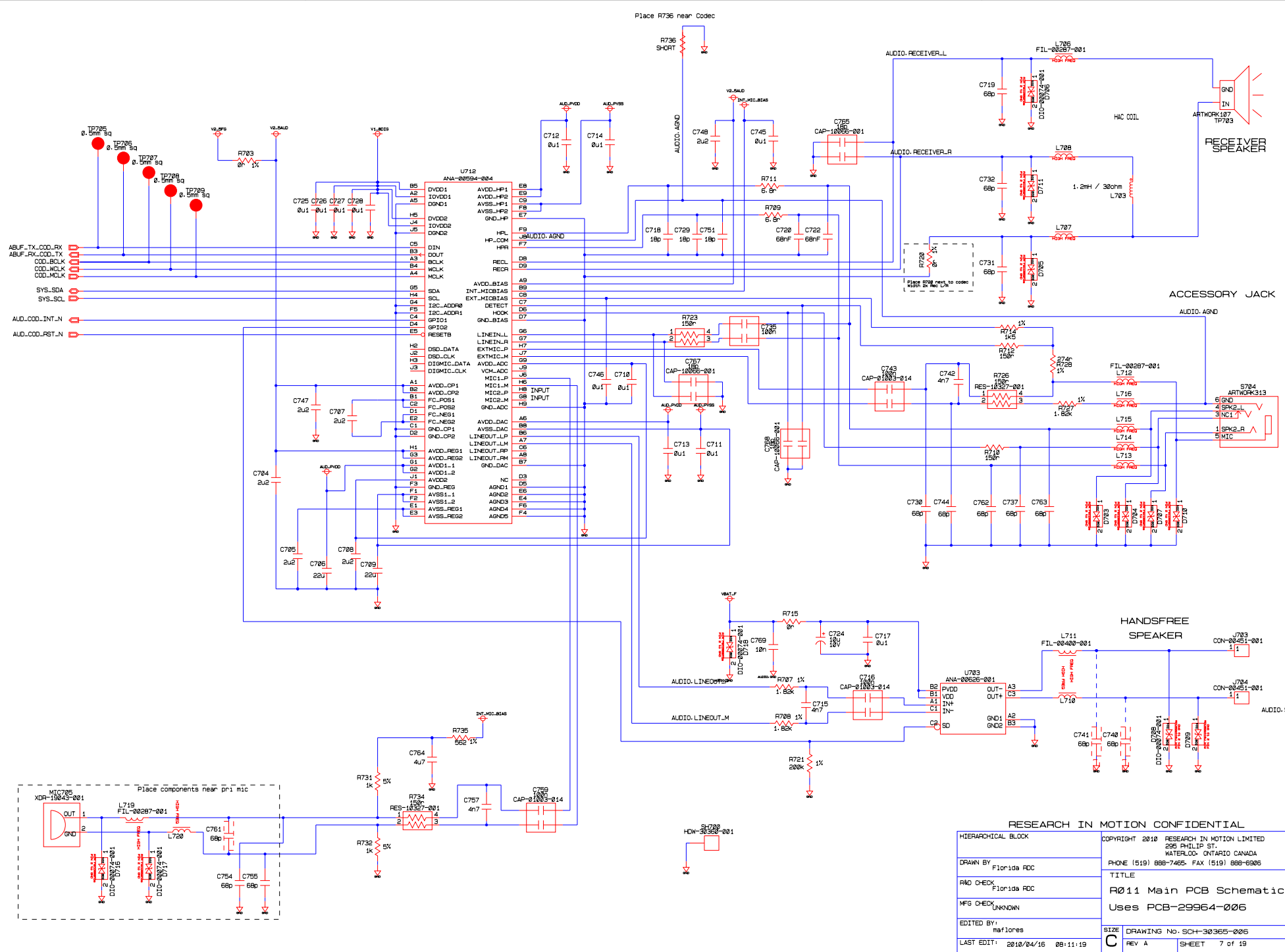

RESEARCH IN MOTION CONFIDENTIAL

HIERARCHICAL BLOCK	COPYRIGHT 2010 RESEARCH IN MOTION LIMITED 295 PHILIP ST. WATERLOO, ONTARIO CANADA PHONE (519) 888-7465, FAX (519) 888-6986
DRAWN BY F1or1da PDC	TITLE R011 Main PCB Schematic Uses PCB-29964-006
RMD CHECK F1or1da PDC	SIZE DRAWING No. SCH-30365-006
MFG CHECK UNKNOWN	REV A SHEET 7 of 19
EDITED BY maf1ores	
LAST EDIT: 2010/04/16 09:11:19	

LCD CONNECTOR

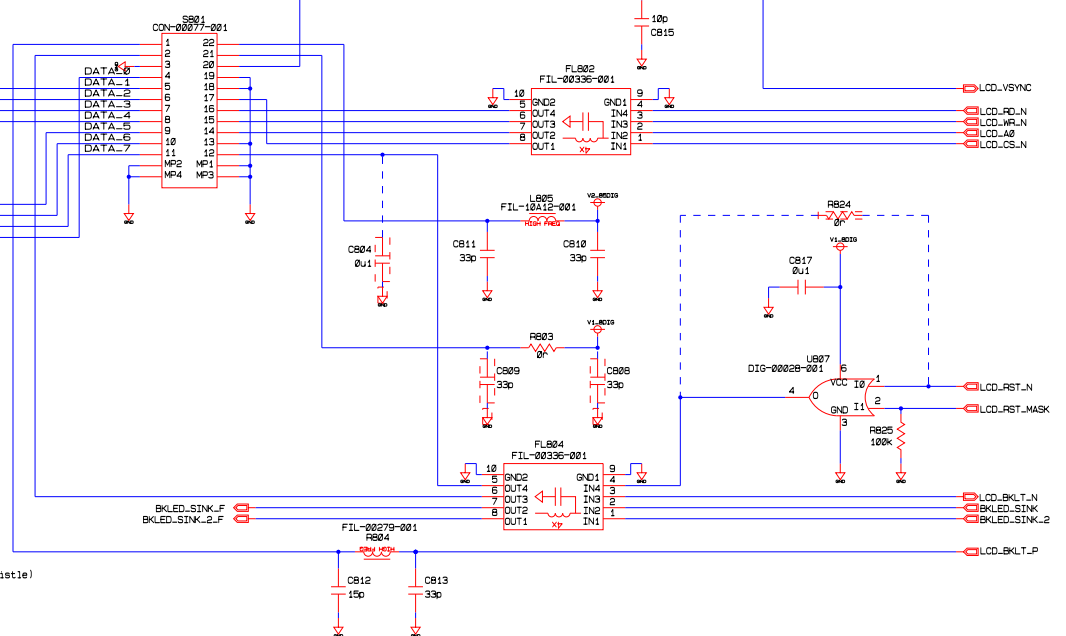

OPTICAL NAVIGATION MODULE CONNECTOR

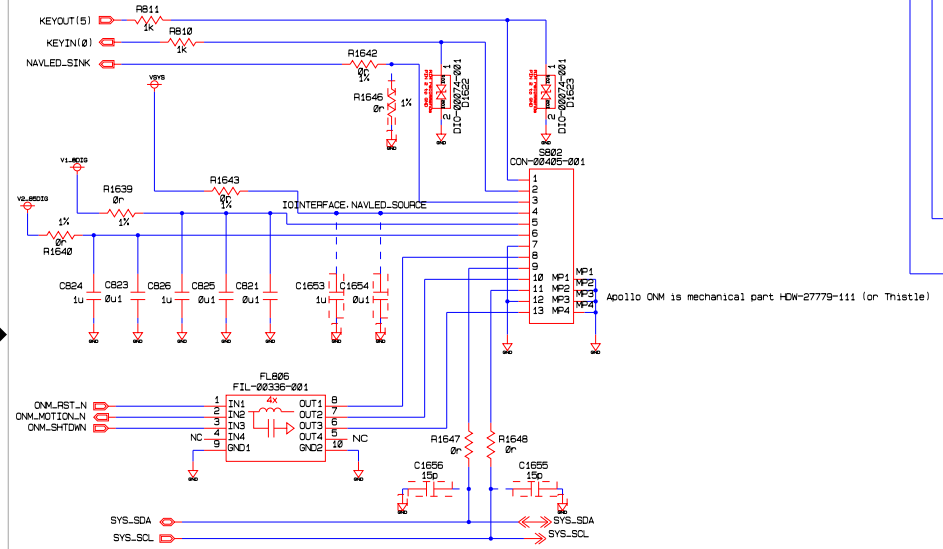

Apollo ONM is mechanical part HDW-27779-111 (or Thistle)

CHARGE/USB CONNECTOR

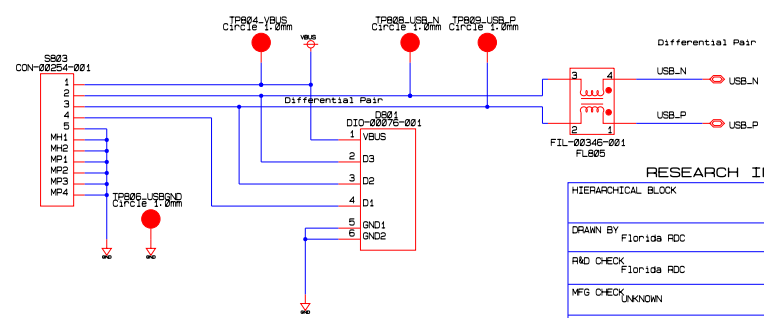

RESEARCH IN MOTION CONFIDENTIAL	
HIERARCHICAL BLOCK	COPYRIGHT 2010 RESEARCH IN MOTION LIMITED 295 PHILIP ST. WATERLOO, ONTARIO CANADA
DRAWN BY: F10r1da RDC	PHONE (519) 888-7465 FAX (519) 888-6906
RMD CHECK: F10r1da RDC	TITLE: R011 Main PCB Schematic
MFG CHECK: UNKNOWN	Uses PCB-29964-006
EDITED BY: maflores	SIZE: DRAWING No. SCH-30365-006
LAST EDIT: 2010/04/16 08:11:19	REV A SHEET 8 of 19

POWER2

BQHuge

ANA-30852-002

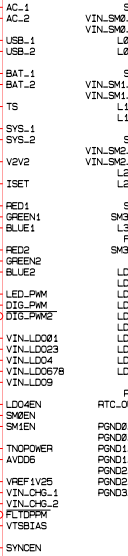

Route as a plane Under BQHuge via Vias

Apollo does not support AC Change

WARNING: EXPLOSIVE*
FOLLOW MANUFACTURERS
ASSEMBLY/REWORK INSTRUCTIONS
DISCHARGE BEFORE REWORK
DO NOT OVER HEAT

RESEARCH IN MOTION CONFIDENTIAL	
HIERARCHICAL BLOCK	COPYRIGHT 2010 RESEARCH IN MOTION LIMITED 295 PHILIP ST. WATERLOO, ONTARIO CANADA PHONE (519) 888-7465. FAX (519) 888-6906
DRAWN BY F10r1da PDC	TITLE R011 Main PCB Schematic Uses PCB-29964-006
RMD CHECK F10r1da PDC	SIZE DRAWING No. SCH-30365-006
MFG CHECK UNKNOWN	REV A SHEET 9 of 19
EDITED BY: maflones	
LAST EDIT: 2010/04/16 09:11:19	

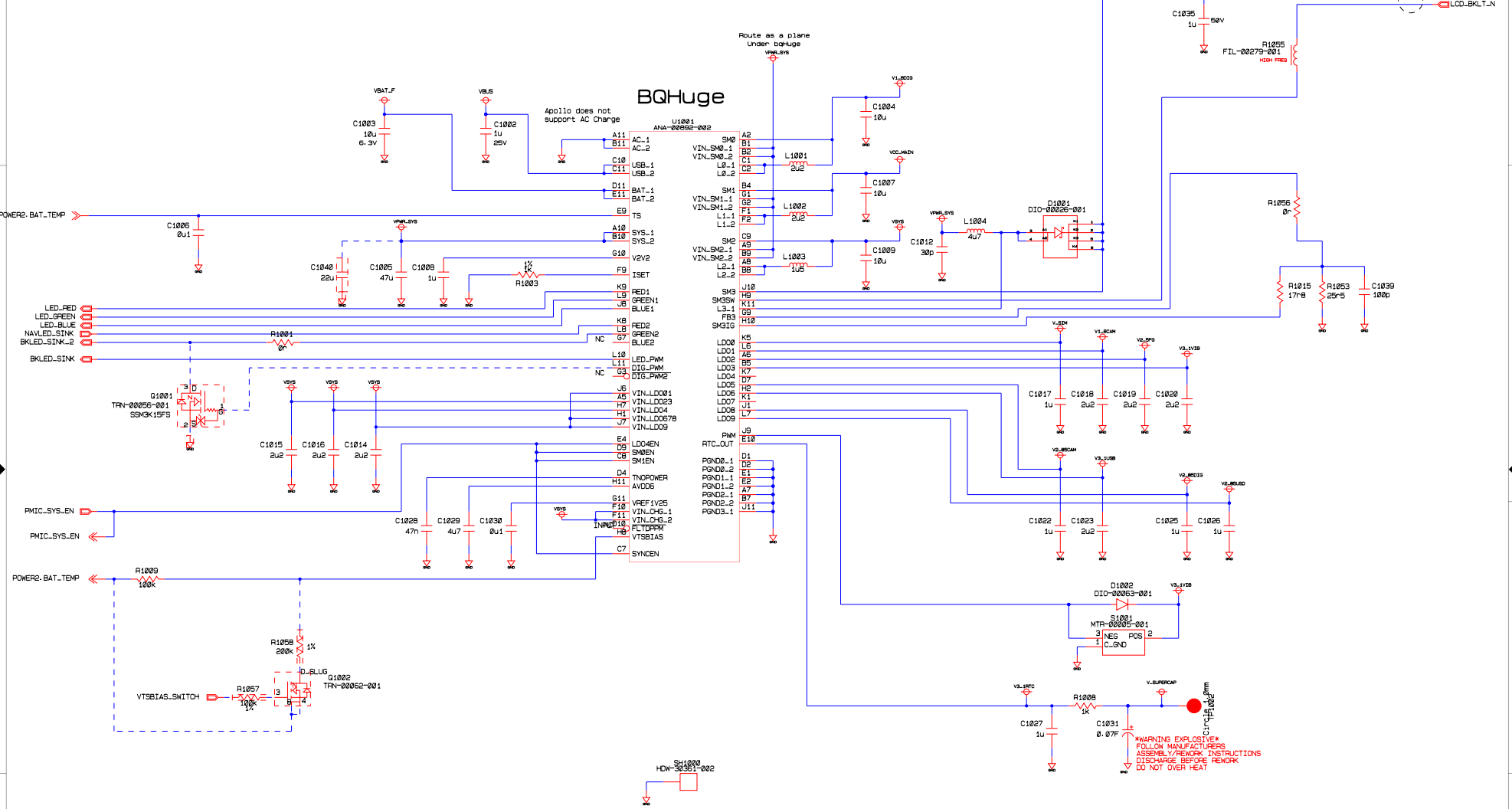

POWER

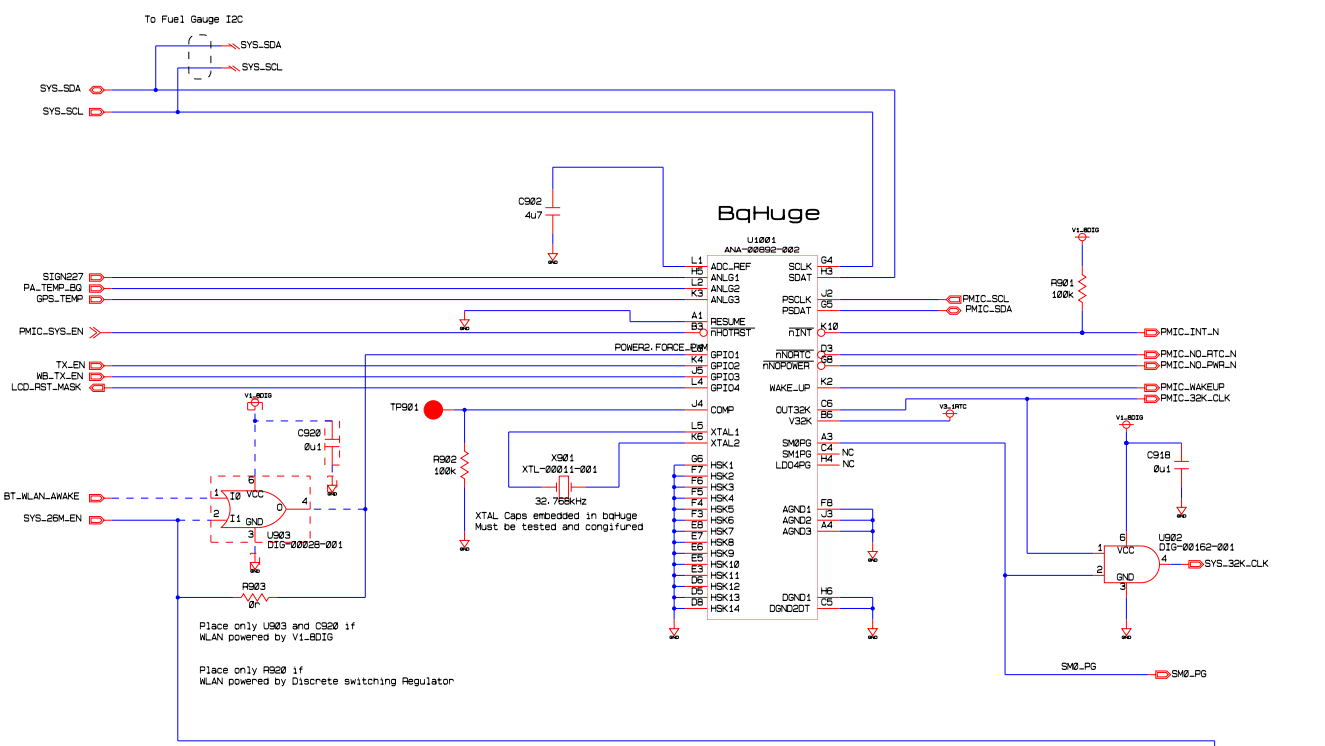

Nets between R909 and U901 SRP/N routed as kevin connection placement should follow configuration below

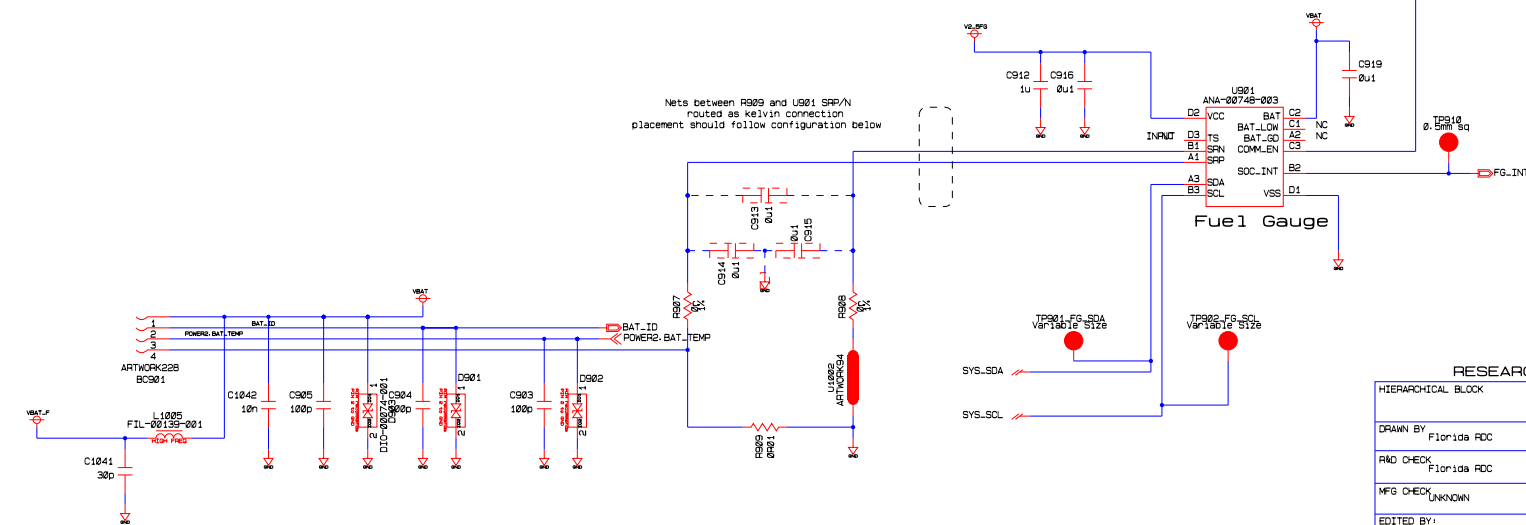

RESEARCH IN MOTION CONFIDENTIAL	
HIERARCHICAL BLOCK	COPYRIGHT 2010 RESEARCH IN MOTION LIMITED 295 PHILIP ST. WATERLOO, ONTARIO CANADA
DRAWN BY F1or1da PDC	PHONE (519) 889-7465 FAX (519) 889-6986
RWD CHECK F1or1da PDC	TITLE R011 Main PCB Schematic
MFG CHECK UNKNOWN	Uses PCB-29964-006
EDITED BY mar1ones	SIZE DRAWING No. SCH-30365-006
LAST EDIT: 2010/04/16 09:11:20	REV A SHEET 10 of 19

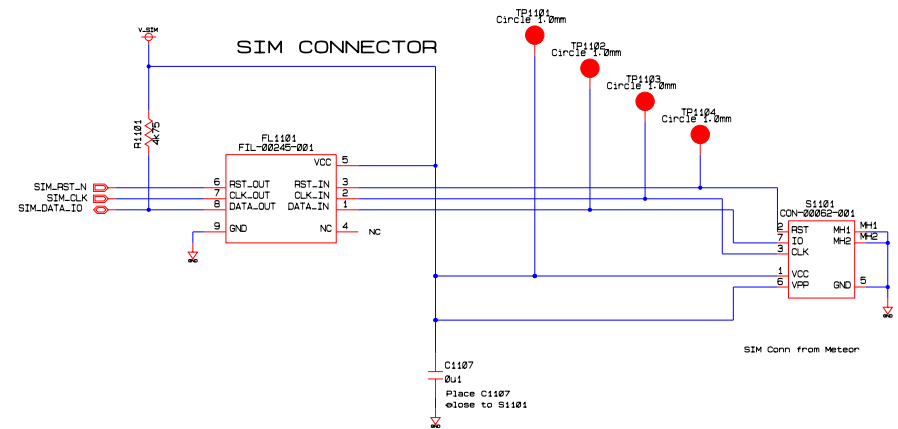

HOLSTER MAGNET DETECTION
(hall effect proximity sensor)

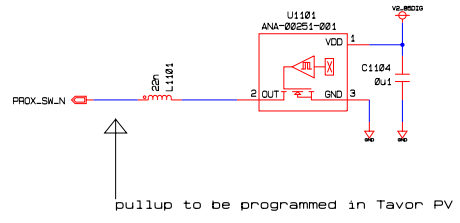

RESEARCH IN MOTION CONFIDENTIAL

HIERARCHICAL BLOCK	COPYRIGHT 2010 RESEARCH IN MOTION LIMITED 295 PHILIP ST. WATERLOO, ONTARIO CANADA PHONE (519) 888-7465 FAX (519) 888-6986
DRAWN BY: F10r1da RDC	TITLE
R&D CHECK: F10r1da RDC	R011 Main PCB Schematic
MFG CHECK: UNKNOWN	Uses PCB-29964-006
EDITED BY: enattaway	SIZE
LAST EDIT: 2010/04/16 08:11:19	DRAWING No. SCH-30365-006
	REV A SHEET 11 of 19

BT_WLAN

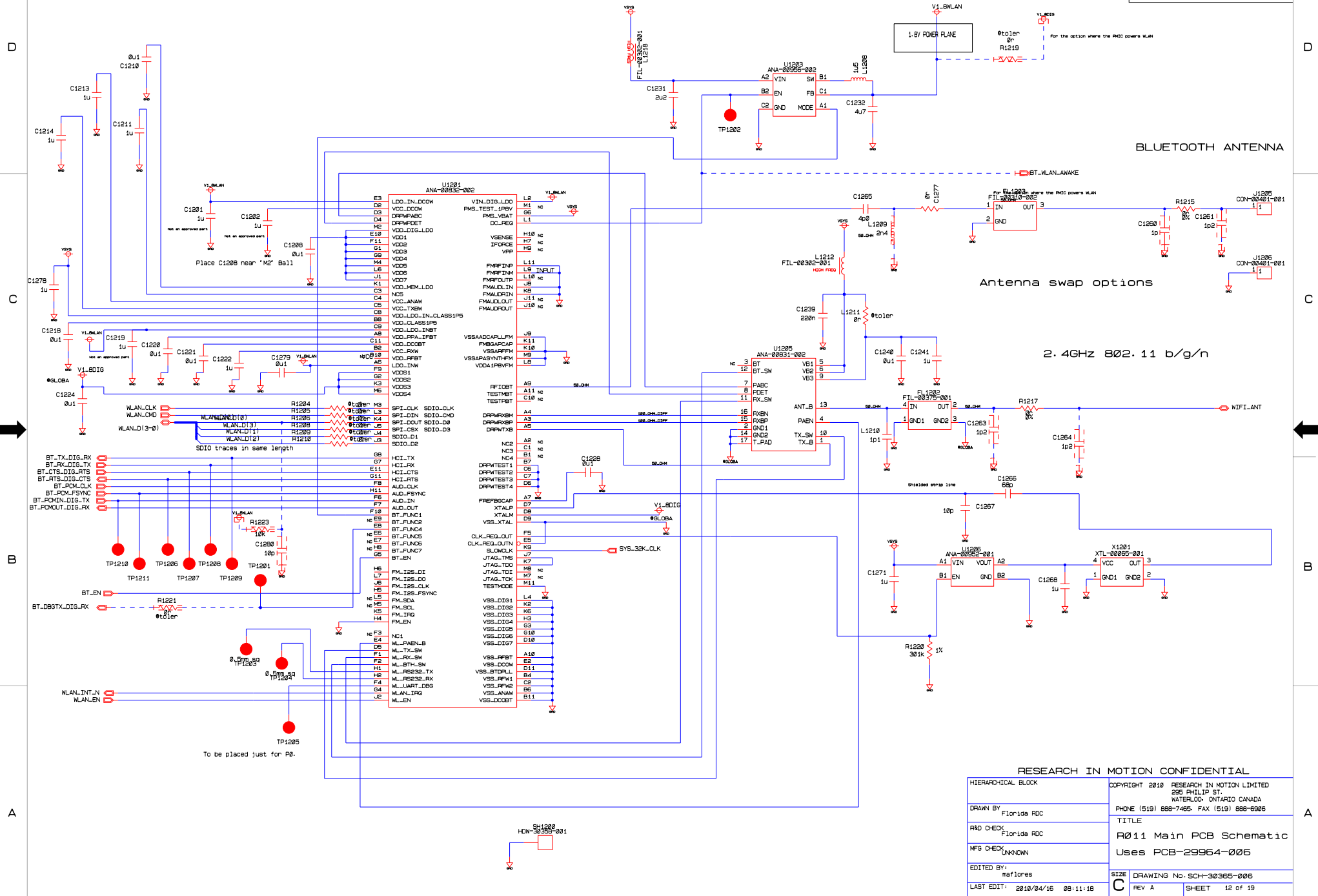

RESEARCH IN MOTION CONFIDENTIAL	
HIERARCHICAL BLOCK	COPYRIGHT 2010 RESEARCH IN MOTION LIMITED 295 PHILIP ST. WATERLOO, ONTARIO CANADA PHONE (519) 888-7465 FAX (519) 888-6986
DRAWN BY F10r1da RDC	TITLE R011 Main PCB Schematic
RWD CHECK F10r1da RDC	Uses PCB-29964-006
MFG CHECK UNKNOWN	
EDITED BY maflores	SIZE DRAWING No. SCH-30365-006
LAST EDIT: 2010/04/16 08:11:18	C REV A SHEET 12 of 19

TAVOR_GPIO

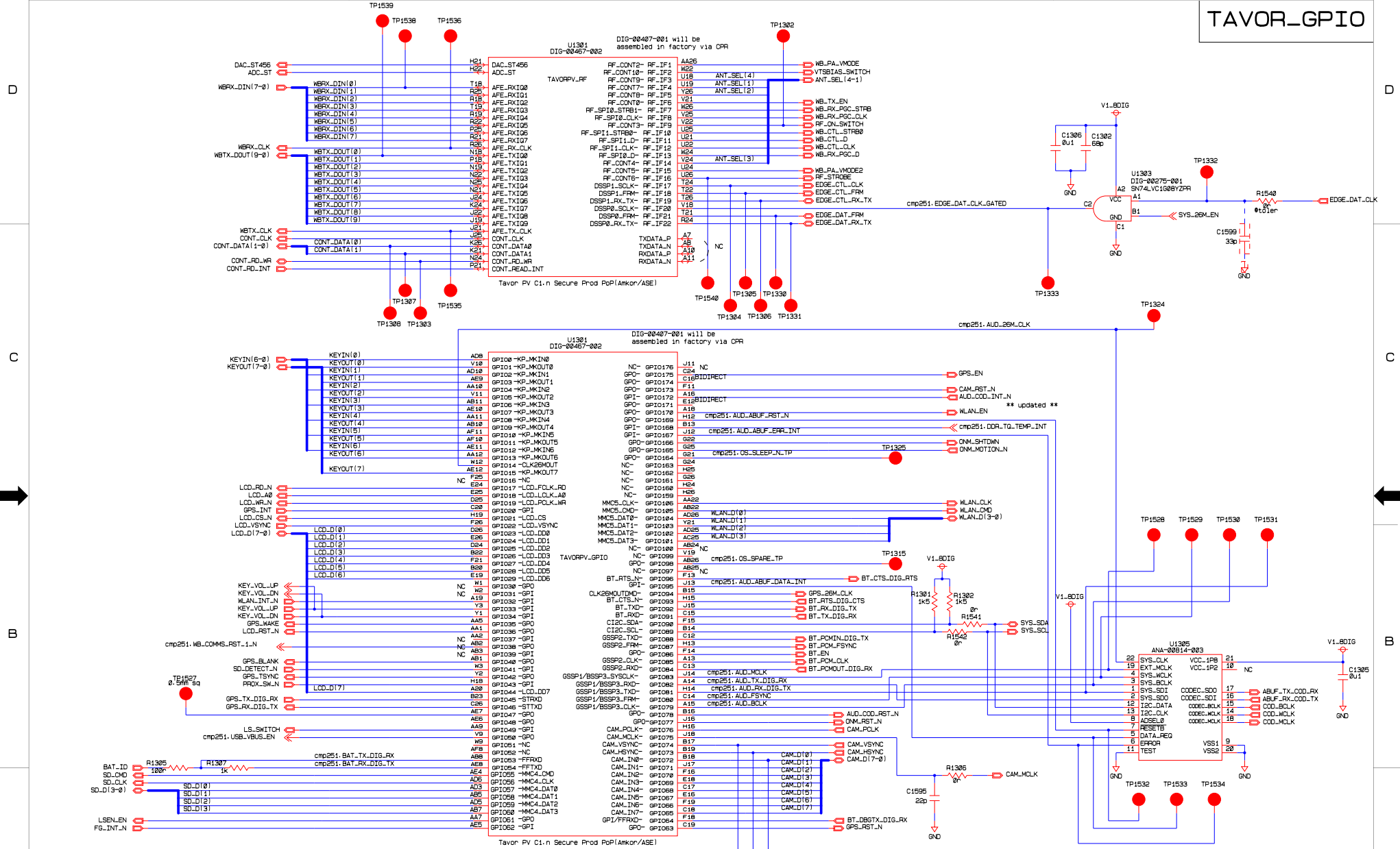

RESEARCH IN MOTION CONFIDENTIAL	
HIERARCHICAL_BLOCK	COPYRIGHT 2010 RESEARCH IN MOTION LIMITED 295 PHILLIP ST. WATERLOO, ONTARIO CANADA
DRAWN BY	F1or1da PDC
PHONE (519) 888-7465 FAX (519) 888-6986	
RWD CHECK	F1or1da PDC
TITLE	R#11 Main PCB Schematic
MFG CHECK	UNKNOWN
Uses PCB-29964-006	
EDITED BY:	maflones
SIZE	DRAWING No. SCH-30365-006
LAST EDIT:	2010/04/16 09:11:19
REV	A
SHEET	13 of 19

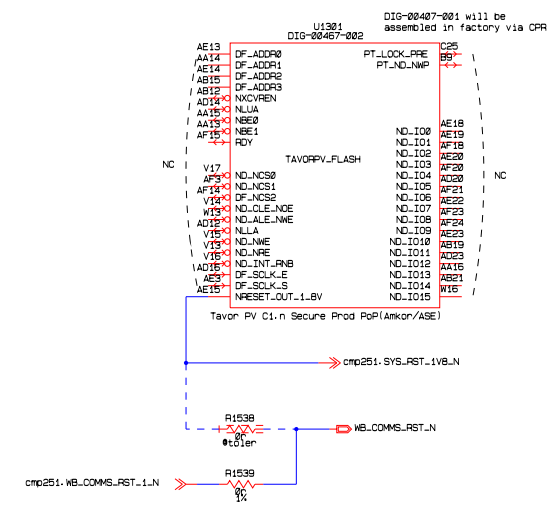
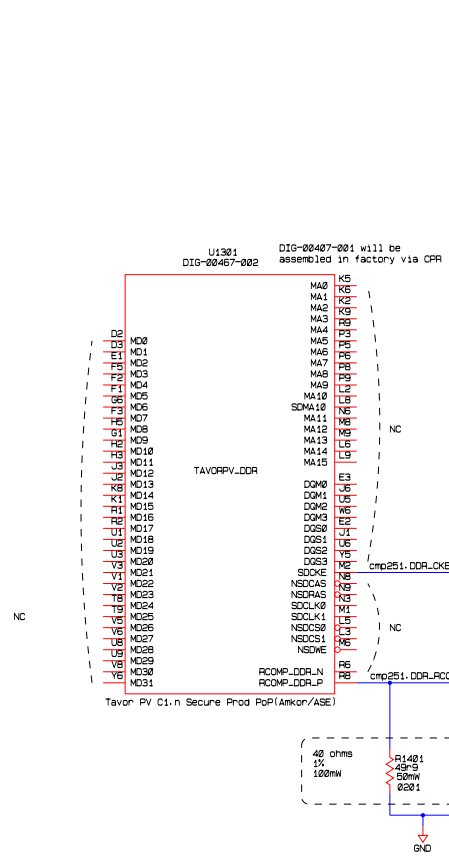

U1401 PRG-31766-001
Stacked Part

Unprogrammed Moonstone is STK-02003-002

RESEARCH IN MOTION CONFIDENTIAL

HIERARCHICAL BLOCK	COPYRIGHT 2010 RESEARCH IN MOTION LIMITED 295 PHILLIP ST. WATERLOO, ONTARIO CANADA
DRAWN BY: F10r1da RDC	PHONE (519) 888-7465 FAX (519) 888-6986
RMD CHECK: F10r1da RDC	TITLE
MFG CHECK: UNKNOWN	R011 Main PCB Schematic
EDITED BY: maflores	Uses PCB-29964-006
LAST EDIT: 2010/04/16 08:11:19	SIZE: DRAWING No. SCH-30365-006
	REV A SHEET 14 of 19

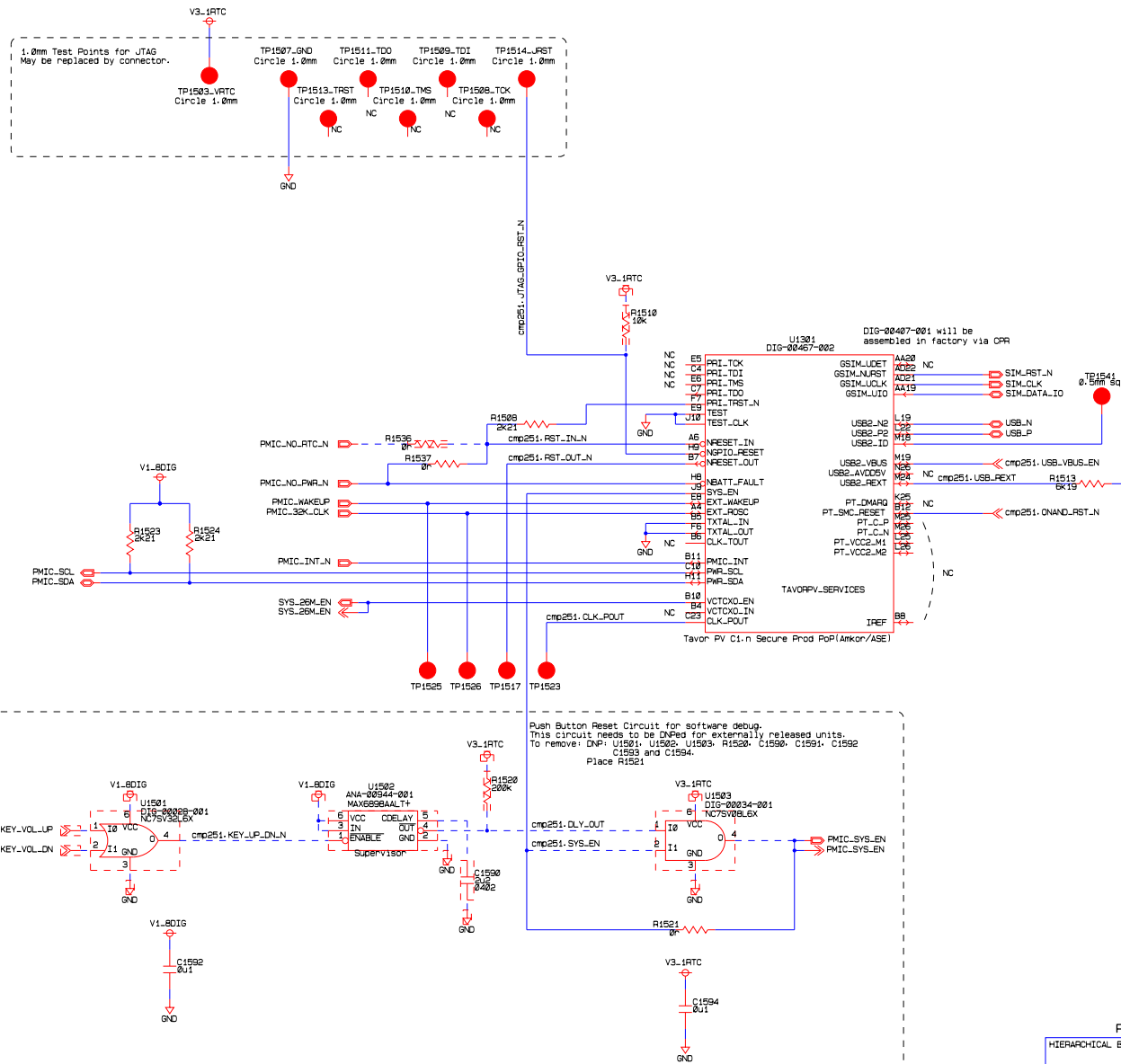

RESEARCH IN MOTION CONFIDENTIAL	
HIERARCHICAL BLOCK	COPYRIGHT 2010 RESEARCH IN MOTION LIMITED 295 PHILIP ST. WATERLOO, ONTARIO CANADA
DRAWN BY	PHONE (519) 889-7465, FAX (519) 888-6986
RWD CHECK	TITLE
MFG CHECK	R011 Main PCB Schematic
EDITED BY:	Uses PCB-29964-006
LAST EDIT:	SIZE
2010/04/16 08:11:19	DRAWING No. SCH-30365-006
	REV A SHEET 15 of 19

IO_INTERF2

TRI-COLOR LED

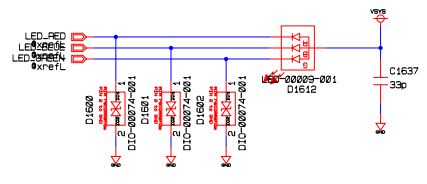

Ambient Light Sensor LIGHT SENSOR

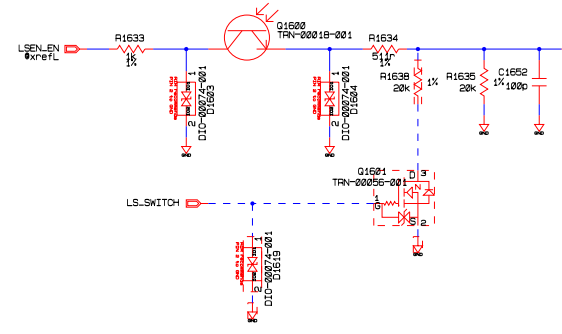

SD Card Connector

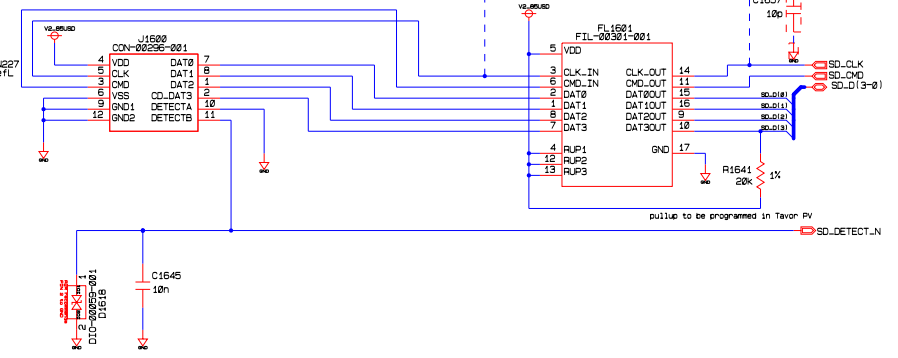

2MP Camera

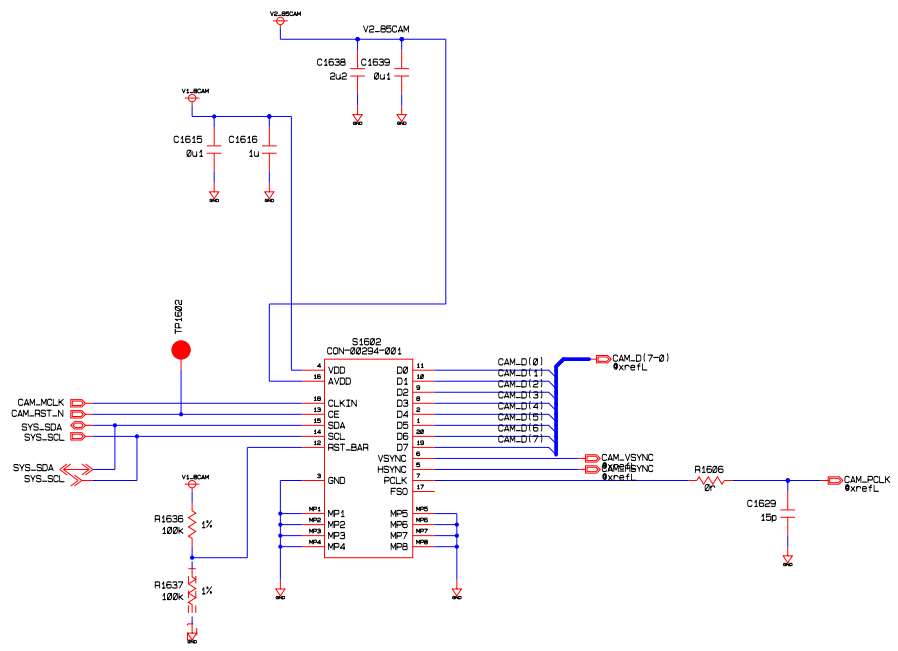

RESEARCH IN MOTION CONFIDENTIAL

HIERARCHICAL_BLOCK	COPYRIGHT 2010 RESEARCH IN MOTION LIMITED 295 PHILIP ST. WATERLOO, ONTARIO CANADA PHONE (519) 888-7465 FAX (519) 888-6986
DRAWN BY F10r1da RDC	TITLE R011 Main PCB Schematic
RND CHECK F10r1da RDC	Uses PCB-29964-006
MFG CHECK UNKNOWN	
EDITED BY: maflores	SIZE DRAWING No. SCH-30365-006
LAST EDIT: 2010/04/16 08:11:19	REV A SHEET 16 of 19

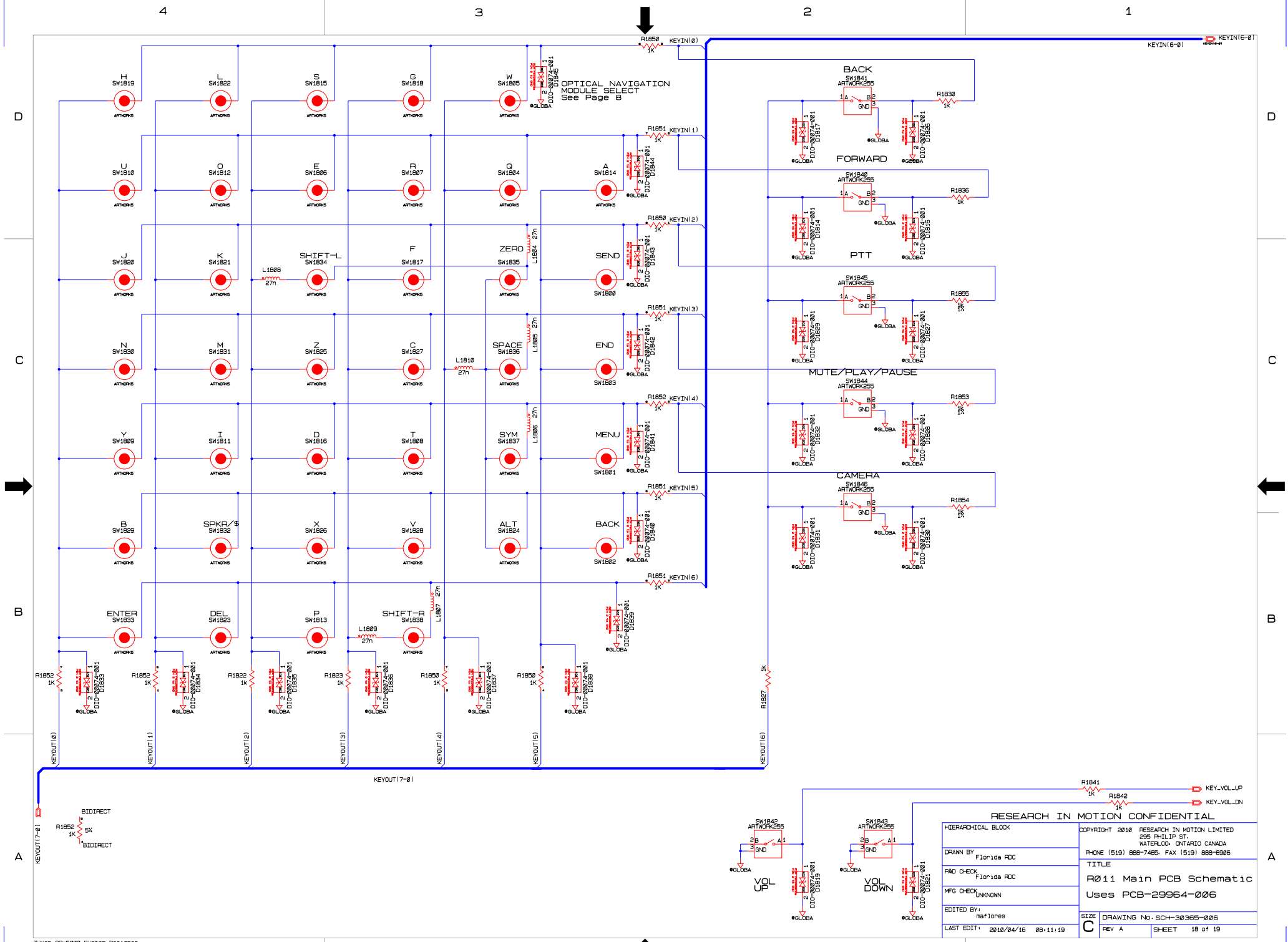

OPTICAL NAVIGATION
MODULE SELECT
See Page 8

BACK
SW1841
ARTWORK255

FORWARD
SW1840
ARTWORK255

PTT
SW1845
ARTWORK255

MUTE/PLAY/PAUSE
SW1844
ARTWORK255

CAMERA
SW1846
ARTWORK255

RESEARCH IN MOTION CONFIDENTIAL	
HIERARCHICAL BLOCK	COPYRIGHT 2010 RESEARCH IN MOTION LIMITED 295 PHILIP ST. WATERLOO, ONTARIO CANADA PHONE (519) 889-7465 FAX (519) 888-6906
DRAWN BY F10r1da PDC	TITLE R011 Main PCB Schematic Uses PCB-29964-006
RWD CHECK F10r1da PDC	SIZE DRAWING No. SCH-30365-006
MFG CHECK UNKNOWN	REV A SHEET 18 of 19
EDITED BY: maf1ores	LAST EDIT: 2010/04/16 09:11:19

