	Document		Page
	Appendix C for the BlackBerry® Smartphone Model RCX71UW SAR Report		1(58)
Author Data	Dates of Test	Test Report No	FCC ID:
Andrew Becker	February 02 – March 03, 2010	RTS-2474-1002-41	L6ARCX70UW

APPENDIX C: SAR DISTRIBUTION PLOTS FOR BODY-WORN CONFIGURATION

	Document		Page
	Appendix C for the BlackBerry® Smartphone Model RCX71UW SAR Report		2(58)
Author Data	Dates of Test	Test Report No	FCC ID:
Andrew Becker	February 02 – March 03, 2010	RTS-2474-1002-41	L6ARCX70UW

Date/Time: 16/02/2010 11:25:30 PM

Test Laboratory: RIM TESTING SERVICES

File Name:

[Vertical_Holster_Back_GPRS850_low_chan_amb_temp_23.1C_liq_temp_22.0C.da4](#)

DUT: BlackBerry Smartphone; Type: Sample ; Serial: 21D06A83

Program Name: Compliance Testing: (Body worn)

Communication System: GPRS 850; Frequency: 824.2 MHz; Duty Cycle: 1:4.2

Medium parameters used: $f = 825$ MHz; $\sigma = 0.933$ mho/m; $\epsilon_r = 56.1$; $\rho = 1000$ kg/m³

Phantom section: Flat Section

DASY4 Configuration:

- Probe: ET3DV6 - SN1644; ConvF(5.87, 5.87, 5.87); Calibrated: 11/11/2009
- Sensor-Surface: 4mm (Mechanical Surface Detection)
- Electronics: DAE3 Sn472; Calibrated: 03/03/2009
- Phantom: SAM 2; Type: SAM 4.0; Serial: 1080
- Measurement SW: DASY4, V4.7 Build 80; Postprocessing SW: SEMCAD, V1.8 Build 186

Body/Area Scan (51x91x1): Measurement grid: dx=15mm, dy=15mm

Maximum value of SAR (interpolated) = 0.888 mW/g

Body/Zoom Scan (5x5x7) (5x5x7)/Cube 0: Measurement grid: dx=7.5mm, dy=7.5mm, dz=5mm

Reference Value = 32.0 V/m; Power Drift = -0.096 dB

Peak SAR (extrapolated) = 1.03 W/kg

SAR(1 g) = 0.828 mW/g; SAR(10 g) = 0.609 mW/g

Maximum value of SAR (measured) = 0.876 mW/g

	Document Appendix C for the BlackBerry® Smartphone Model RCX71UW SAR Report		Page 3(58)
	Author Data Andrew Becker	Dates of Test February 02 – March 03, 2010	Test Report No RTS-2474-1002-41

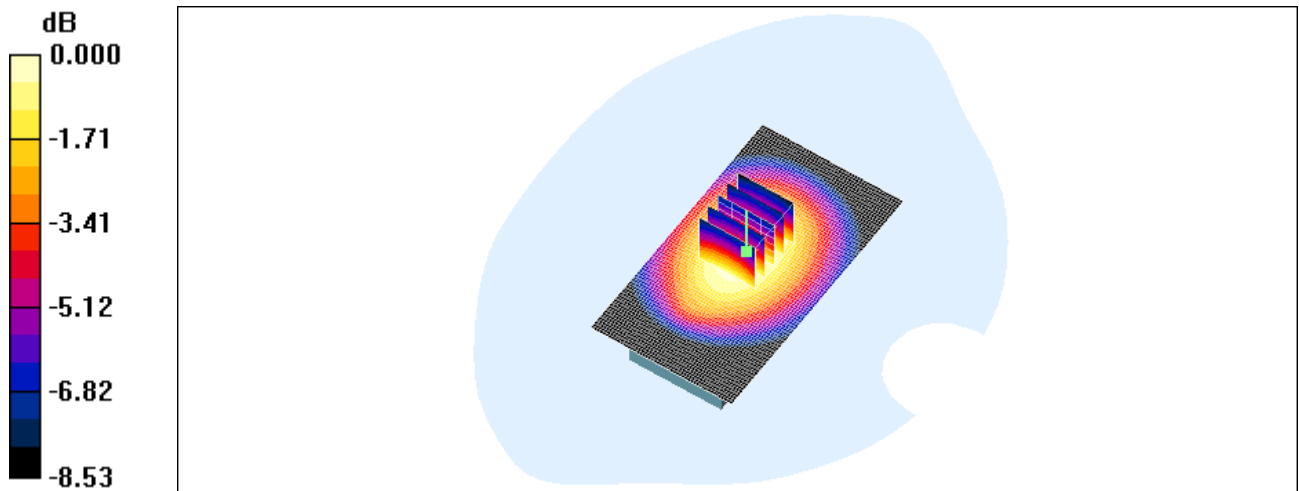

0 dB = 0.876mW/g

	Document		Page
	Appendix C for the BlackBerry® Smartphone Model RCX71UW SAR Report		4(58)
Author Data	Dates of Test	Test Report No	FCC ID:
Andrew Becker	February 02 – March 03, 2010	RTS-2474-1002-41	L6ARCX70UW

Date/Time: 16/02/2010 11:43:31 PM

Test Laboratory: RIM TESTING SERVICES

File Name:

[Vertical_Holster_Back_GPRS850_mid_chan_amb_temp_23.1C_liq_temp_22.0C.da4](#)

DUT: BlackBerry Smartphone; Type: Sample ; Serial: 21D06A83

Program Name: Compliance Testing: (Body worn)

Communication System: GPRS 850; Frequency: 836.8 MHz; Duty Cycle: 1:4.2

Medium parameters used (interpolated): $f = 836.8 \text{ MHz}$; $\sigma = 0.946 \text{ mho/m}$; $\epsilon_r = 56.1$; $\rho = 1000 \text{ kg/m}^3$

Phantom section: Flat Section

DASY4 Configuration:

- Probe: ET3DV6 - SN1644; ConvF(5.87, 5.87, 5.87); Calibrated: 11/11/2009
- Sensor-Surface: 4mm (Mechanical Surface Detection)
- Electronics: DAE3 Sn472; Calibrated: 03/03/2009
- Phantom: SAM 2; Type: SAM 4.0; Serial: 1080
- Measurement SW: DASY4, V4.7 Build 80; Postprocessing SW: SEMCAD, V1.8 Build 186

Body/Area Scan (51x91x1): Measurement grid: $dx=15\text{mm}$, $dy=15\text{mm}$

[Info: Interpolated medium parameters used for SAR evaluation.](#)

Maximum value of SAR (interpolated) = 1.03 mW/g

Body/Zoom Scan (5x5x7) (5x5x7)/Cube 0: Measurement grid: $dx=7.5\text{mm}$, $dy=7.5\text{mm}$, $dz=5\text{mm}$

Reference Value = 34.2 V/m; Power Drift = -0.066 dB

Peak SAR (extrapolated) = 1.22 W/kg

SAR(1 g) = 0.979 mW/g; SAR(10 g) = 0.716 mW/g

[Info: Interpolated medium parameters used for SAR evaluation.](#)

Maximum value of SAR (measured) = 1.03 mW/g

	Document Appendix C for the BlackBerry® Smartphone Model RCX71UW SAR Report		Page 5(58)
	Author Data Andrew Becker	Dates of Test February 02 – March 03, 2010	Test Report No RTS-2474-1002-41

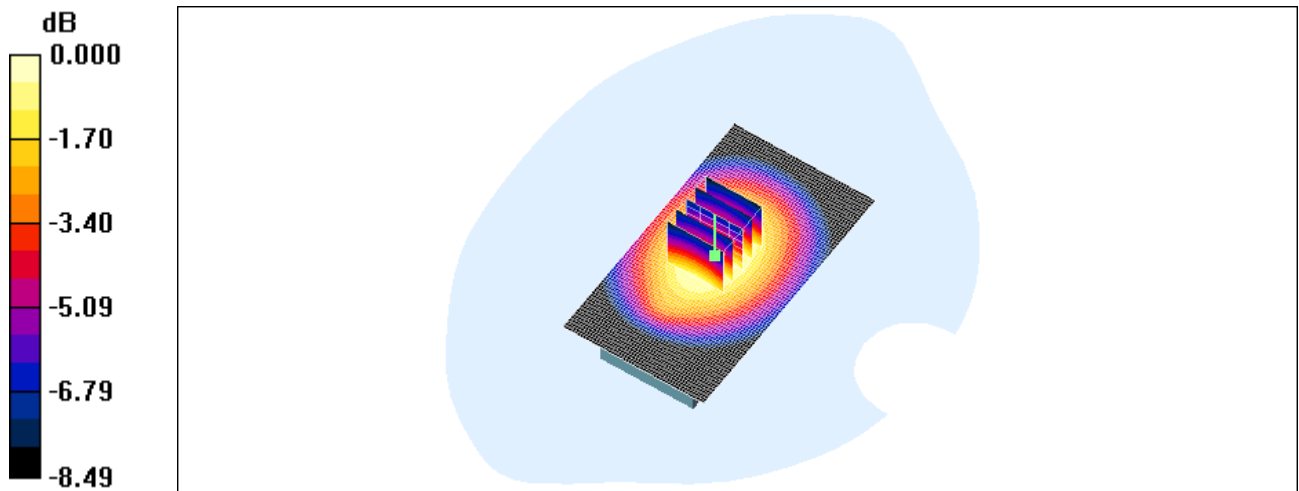

0 dB = 1.03mW/g

	Document		Page
	Appendix C for the BlackBerry® Smartphone Model RCX71UW SAR Report		6(58)
Author Data	Dates of Test	Test Report No	FCC ID:
Andrew Becker	February 02 – March 03, 2010	RTS-2474-1002-41	L6ARCX70UW

Date/Time: 16/02/2010 11:57:52 PM

Test Laboratory: RIM TESTING SERVICES

File Name:

[Vertical_Holster_Back_GPRS850_high_chan_amb_temp_23.1C_liq_temp_22.0C.da4](#)

DUT: BlackBerry Smartphone; Type: Sample ; Serial: 21D06A83

Program Name: Compliance Testing: (Body worn)

Communication System: GPRS 850; Frequency: 848.8 MHz; Duty Cycle: 1:4.2

Medium parameters used (interpolated): $f = 848.8 \text{ MHz}$; $\sigma = 0.958 \text{ mho/m}$; $\epsilon_r = 55.9$; $\rho = 1000 \text{ kg/m}^3$

Phantom section: Flat Section

DASY4 Configuration:

- Probe: ET3DV6 - SN1644; ConvF(5.87, 5.87, 5.87); Calibrated: 11/11/2009
- Sensor-Surface: 4mm (Mechanical Surface Detection)
- Electronics: DAE3 Sn472; Calibrated: 03/03/2009
- Phantom: SAM 2; Type: SAM 4.0; Serial: 1080
- Measurement SW: DASY4, V4.7 Build 80; Postprocessing SW: SEMCAD, V1.8 Build 186

Body/Area Scan (51x91x1): Measurement grid: $dx=15\text{mm}$, $dy=15\text{mm}$

[Info: Interpolated medium parameters used for SAR evaluation.](#)

Maximum value of SAR (interpolated) = 1.14 mW/g

Body/Zoom Scan (5x5x7) (5x5x7)/Cube 0: Measurement grid: $dx=7.5\text{mm}$, $dy=7.5\text{mm}$, $dz=5\text{mm}$

Reference Value = 35.5 V/m; Power Drift = -0.011 dB

Peak SAR (extrapolated) = 1.32 W/kg

SAR(1 g) = 1.06 mW/g; SAR(10 g) = 0.776 mW/g

[Info: Interpolated medium parameters used for SAR evaluation.](#)

Maximum value of SAR (measured) = 1.13 mW/g

	Document Appendix C for the BlackBerry® Smartphone Model RCX71UW SAR Report		Page 7(58)
	Author Data Andrew Becker	Dates of Test February 02 – March 03, 2010	Test Report No RTS-2474-1002-41

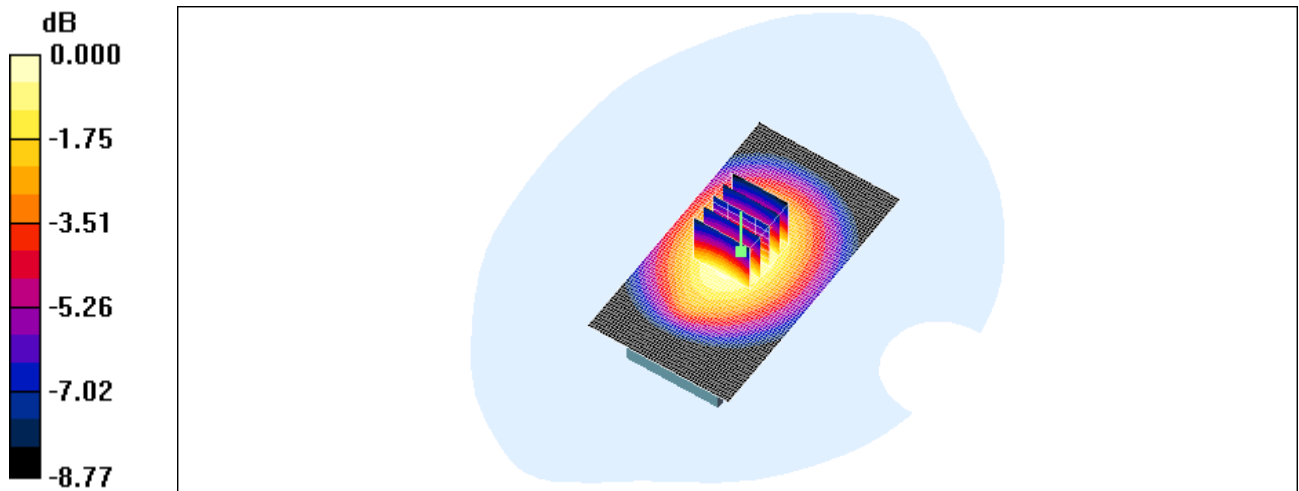

0 dB = 1.13mW/g

	Document		Page
	Appendix C for the BlackBerry® Smartphone Model RCX71UW SAR Report		8(58)
Author Data	Dates of Test	Test Report No	FCC ID:
Andrew Becker	February 02 – March 03, 2010	RTS-2474-1002-41	L6ARCX70UW

Date/Time: 17/02/2010 12:13:57 AM

Test Laboratory: RIM TESTING SERVICES

File Name:

[Vertical_Holster_Front_GPRS850_high_chan_amb_temp_23.1C_liq_temp_22.0C.da4](#)

DUT: BlackBerry Smartphone; Type: Sample ; Serial: 21D06A83

Program Name: Compliance Testing: (Body worn)

Communication System: GPRS 850; Frequency: 848.8 MHz; Duty Cycle: 1:4.2

Medium parameters used (interpolated): $f = 848.8$ MHz; $\sigma = 0.958$ mho/m; $\epsilon_r = 55.9$; $\rho = 1000$ kg/m³

Phantom section: Flat Section

DASY4 Configuration:

- Probe: ET3DV6 - SN1644; ConvF(5.87, 5.87, 5.87); Calibrated: 11/11/2009
- Sensor-Surface: 4mm (Mechanical Surface Detection)
- Electronics: DAE3 Sn472; Calibrated: 03/03/2009
- Phantom: SAM 2; Type: SAM 4.0; Serial: 1080
- Measurement SW: DASY4, V4.7 Build 80; Postprocessing SW: SEMCAD, V1.8 Build 186

Body/Area Scan (51x91x1): Measurement grid: dx=15mm, dy=15mm

[Info: Interpolated medium parameters used for SAR evaluation.](#)

Maximum value of SAR (interpolated) = 0.903 mW/g

Body/Zoom Scan (5x5x7) (5x5x7)/Cube 0: Measurement grid: dx=7.5mm, dy=7.5mm, dz=5mm

Reference Value = 31.9 V/m; Power Drift = -0.072 dB

Peak SAR (extrapolated) = 1.02 W/kg

SAR(1 g) = 0.837 mW/g; SAR(10 g) = 0.620 mW/g

[Info: Interpolated medium parameters used for SAR evaluation.](#)

Maximum value of SAR (measured) = 0.880 mW/g

	Document Appendix C for the BlackBerry® Smartphone Model RCX71UW SAR Report		Page 9(58)
	Author Data Andrew Becker	Dates of Test February 02 – March 03, 2010	Test Report No RTS-2474-1002-41

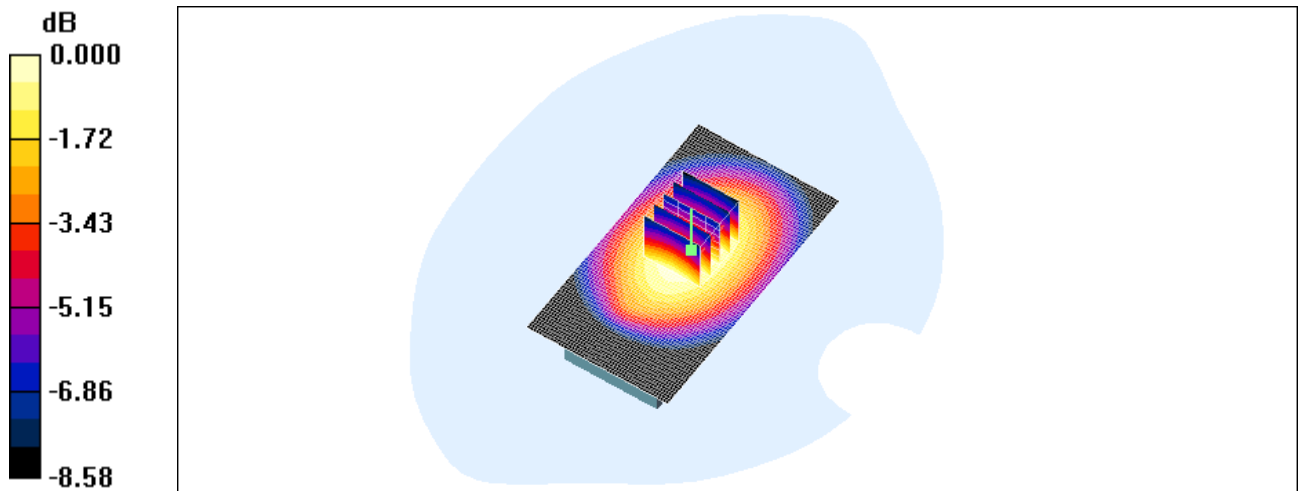

0 dB = 0.880mW/g

	Document		Page
	Appendix C for the BlackBerry® Smartphone Model RCX71UW SAR Report		10(58)
Author Data	Dates of Test	Test Report No	FCC ID:
Andrew Becker	February 02 – March 03, 2010	RTS-2474-1002-41	L6ARCX70UW

Date/Time: 17/02/2010 3:06:04 PM

Test Laboratory: RIM TESTING SERVICES

**Vertical_Holster_HS#1_Back_GPRS850_high_chan_amb_temp_23.1C_I
iq_temp_22.0C**

DUT: BlackBerry Smartphone; Type: Sample ; Serial: 21D06A83

Communication System: GPRS 850; Frequency: 848.8 MHz; Duty Cycle: 1:4.2
Medium parameters used (interpolated): $f = 848.8$ MHz; $\sigma = 0.958$ mho/m; $\epsilon_r = 55.9$; $\rho = 1000$ kg/m³
Phantom section: Flat Section
Measurement Standard: DASY4 (High Precision Assessment)

DASY4 Configuration:

- Probe: ET3DV6 - SN1644; ConvF(5.87, 5.87, 5.87); Calibrated: 11/11/2009
- Sensor-Surface: 4mm (Mechanical Surface Detection)
- Electronics: DAE3 Sn472; Calibrated: 03/03/2009
- Phantom: SAM 2; Type: SAM 4.0; Serial: 1080
- Measurement SW: DASY4, V4.7 Build 80; Postprocessing SW: SEMCAD, V1.8 Build 186

Body/Area Scan (51x91x1): Measurement grid: dx=15mm, dy=15mm

[Info: Interpolated medium parameters used for SAR evaluation.](#)

Maximum value of SAR (interpolated) = 0.901 mW/g

Body/Zoom Scan (5x5x7) (5x5x7)/Cube 0: Measurement grid: dx=7.5mm, dy=7.5mm, dz=5mm

Reference Value = 32.0 V/m; Power Drift = -0.106 dB

Peak SAR (extrapolated) = 1.04 W/kg

SAR(1 g) = 0.834 mW/g; SAR(10 g) = 0.610 mW/g

[Info: Interpolated medium parameters used for SAR evaluation.](#)

Maximum value of SAR (measured) = 0.884 mW/g

	Document Appendix C for the BlackBerry® Smartphone Model RCX71UW SAR Report		Page 11(58)
	Author Data Andrew Becker	Dates of Test February 02 – March 03, 2010	Test Report No RTS-2474-1002-41

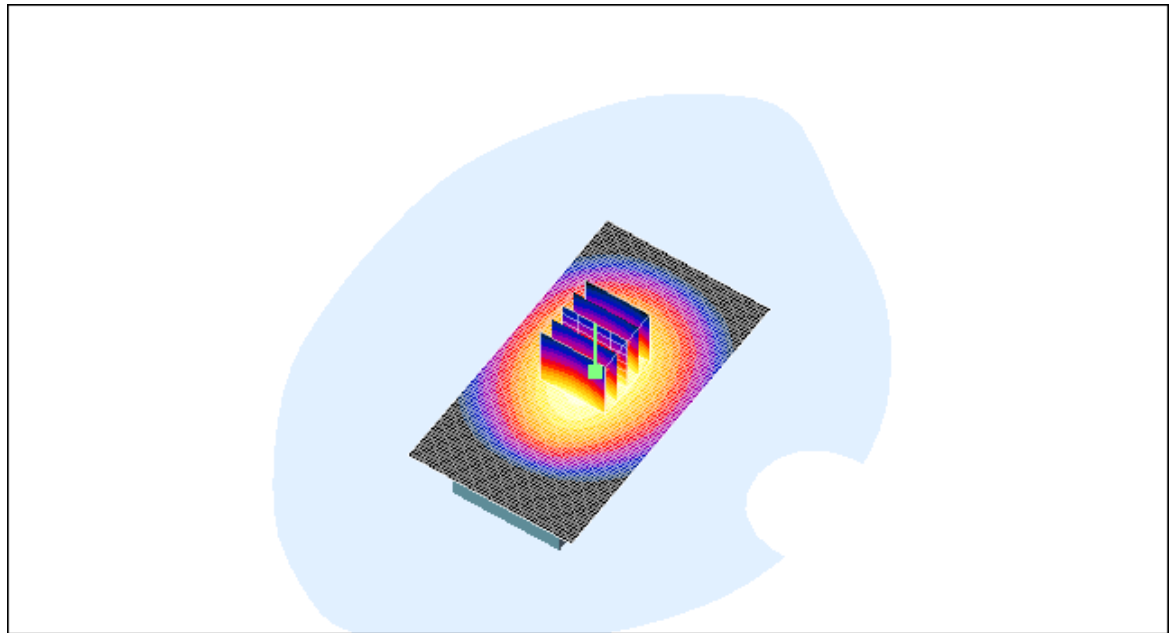
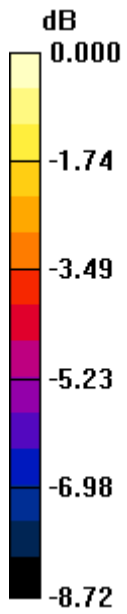

0 dB = 0.884mW/g

	Document		Page
	Appendix C for the BlackBerry® Smartphone Model RCX71UW SAR Report		12(58)
Author Data	Dates of Test	Test Report No	FCC ID:
Andrew Becker	February 02 – March 03, 2010	RTS-2474-1002-41	L6ARCX70UW

Date/Time: 17/02/2010 3:24:10 PM

Test Laboratory: RIM TESTING SERVICES

25mm_Space_Back_GPRS850_high_chan_amb_temp_22.8C_liq_temp_22.1C

DUT: BlackBerry Smartphone; Type: Sample ; Serial: 21D06A83

Communication System: GPRS 850; Frequency: 848.8 MHz; Duty Cycle: 1:4.2
Medium parameters used (interpolated): $f = 848.8$ MHz; $\sigma = 0.958$ mho/m; $\epsilon_r = 55.9$; $\rho = 1000$ kg/m³
Phantom section: Flat Section
Measurement Standard: DASy4 (High Precision Assessment)

DASy4 Configuration:

- Probe: ET3DV6 - SN1644; ConvF(5.87, 5.87, 5.87); Calibrated: 11/11/2009
- Sensor-Surface: 4mm (Mechanical Surface Detection)
- Electronics: DAE3 Sn472; Calibrated: 03/03/2009
- Phantom: SAM 2; Type: SAM 4.0; Serial: 1080
- Measurement SW: DASy4, V4.7 Build 80; Postprocessing SW: SEMCAD, V1.8 Build 186

Body/Area Scan (51x91x1): Measurement grid: dx=15mm, dy=15mm

[Info: Interpolated medium parameters used for SAR evaluation.](#)

Maximum value of SAR (interpolated) = 0.642 mW/g

Body/Zoom Scan (5x5x7) (5x5x7)/Cube 0: Measurement grid: dx=7.5mm, dy=7.5mm, dz=5mm

Reference Value = 26.6 V/m; Power Drift = -0.026 dB

Peak SAR (extrapolated) = 0.747 W/kg

SAR(1 g) = 0.604 mW/g; SAR(10 g) = 0.446 mW/g

[Info: Interpolated medium parameters used for SAR evaluation.](#)

Maximum value of SAR (measured) = 0.639 mW/g

	Document Appendix C for the BlackBerry® Smartphone Model RCX71UW SAR Report		Page 13(58)
	Author Data Andrew Becker	Dates of Test February 02 – March 03, 2010	Test Report No RTS-2474-1002-41

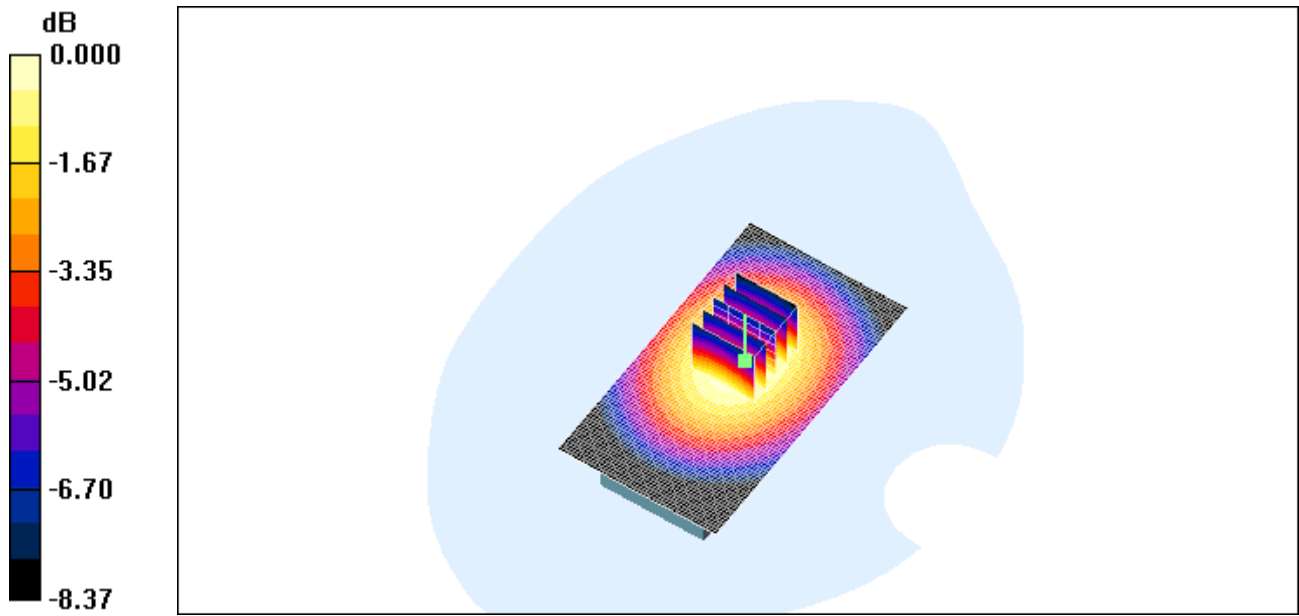

0 dB = 0.639mW/g

	Document		Page
	Appendix C for the BlackBerry® Smartphone Model RCX71UW SAR Report		14(58)
Author Data	Dates of Test	Test Report No	FCC ID:
Andrew Becker	February 02 – March 03, 2010	RTS-2474-1002-41	L6ARCX70UW

Date/Time: 11/02/2010 10:54:40 AM

Test Laboratory: RIM TESTING SERVICES

**Vertical_Holster_Back_UMTS_Band_IV_mid_chan_amb_temp_23.5C_liq
_temp_21.8C**

DUT: BlackBerry Smartphone; Type: Sample ; Serial: 21D06A83

Communication System: WCDMA FDD IV; Frequency: 1732.6 MHz; Duty Cycle: 1:1
Medium parameters used (interpolated): $f = 1732.6$ MHz; $\sigma = 1.37$ mho/m; $\epsilon_r = 51.8$; $\rho = 1000$ kg/m³

Phantom section: Flat Section

Measurement Standard: DAS4 (High Precision Assessment)

DASY4 Configuration:

- Probe: ET3DV6 - SN1644; ConvF(4.69, 4.69, 4.69); Calibrated: 11/11/2009
- Sensor-Surface: 4mm (Mechanical Surface Detection)
- Electronics: DAE3 Sn472; Calibrated: 03/03/2009
- Phantom: SAM 2; Type: SAM 4.0; Serial: 1080
- Measurement SW: DAS4, V4.7 Build 80; Postprocessing SW: SEMCAD, V1.8 Build 186

Body/Area Scan (51x91x1): Measurement grid: dx=15mm, dy=15mm

[Info: Interpolated medium parameters used for SAR evaluation.](#)

Maximum value of SAR (interpolated) = 0.715 mW/g

Body/Zoom Scan (5x5x7) (5x5x7)/Cube 0: Measurement grid: dx=7.5mm, dy=7.5mm, dz=5mm

Reference Value = 6.63 V/m; Power Drift = -0.157 dB

Peak SAR (extrapolated) = 0.871 W/kg

SAR(1 g) = 0.640 mW/g; SAR(10 g) = 0.391 mW/g

[Info: Interpolated medium parameters used for SAR evaluation.](#)

Maximum value of SAR (measured) = 0.711 mW/g

	Document Appendix C for the BlackBerry® Smartphone Model RCX71UW SAR Report		Page 15(58)
	Author Data Andrew Becker	Dates of Test February 02 – March 03, 2010	Test Report No RTS-2474-1002-41

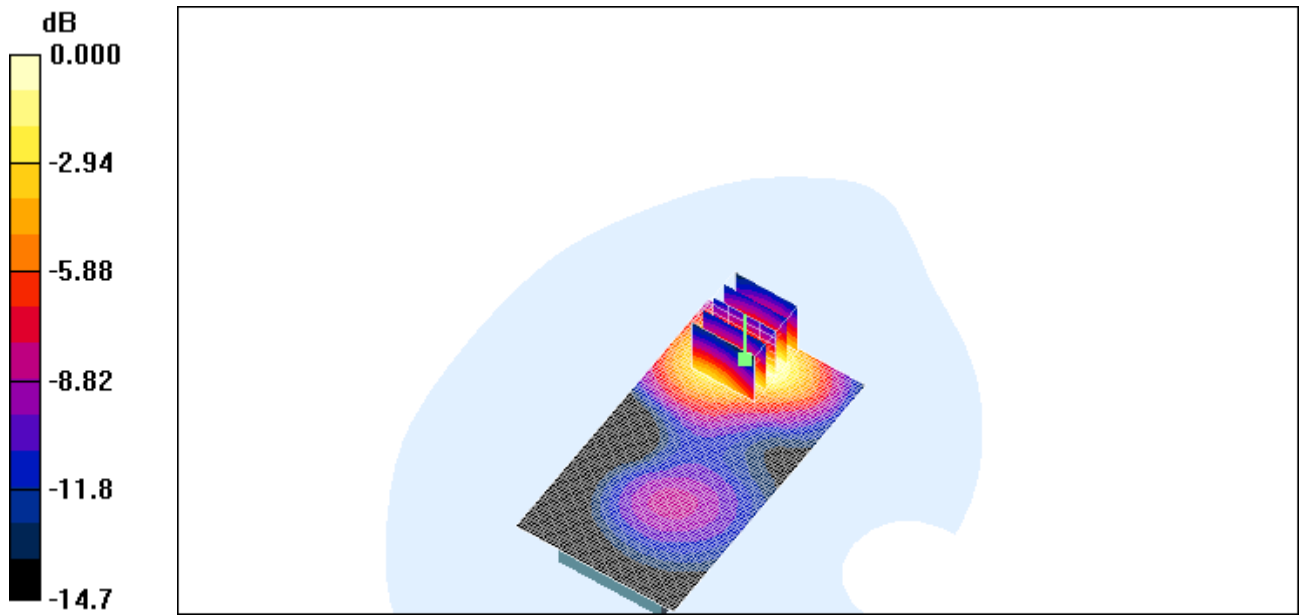

0 dB = 0.711mW/g

	Document		Page
	Appendix C for the BlackBerry® Smartphone Model RCX71UW SAR Report		16(58)
Author Data	Dates of Test	Test Report No	FCC ID:
Andrew Becker	February 02 – March 03, 2010	RTS-2474-1002-41	L6ARCX70UW

Date/Time: 11/02/2010 12:18:30 PM

Test Laboratory: RIM TESTING SERVICES

**Vertical_Holster_Front_UMTS_Band_IV_mid_chan_amb_temp_22.9C_li
q_temp_21.5C**

DUT: BlackBerry Smartphone; Type: Sample ; Serial: 21D06A83

Communication System: WCDMA FDD IV; Frequency: 1732.6 MHz; Duty Cycle: 1:1
Medium parameters used (interpolated): $f = 1732.6$ MHz; $\sigma = 1.37$ mho/m; $\epsilon_r = 51.8$; $\rho = 1000$ kg/m³

Phantom section: Flat Section

Measurement Standard: DAS4 (High Precision Assessment)

DASY4 Configuration:

- Probe: ET3DV6 - SN1644; ConvF(4.69, 4.69, 4.69); Calibrated: 11/11/2009
- Sensor-Surface: 4mm (Mechanical Surface Detection)
- Electronics: DAE3 Sn472; Calibrated: 03/03/2009
- Phantom: SAM 2; Type: SAM 4.0; Serial: 1080
- Measurement SW: DAS4, V4.7 Build 80; Postprocessing SW: SEMCAD, V1.8 Build 186

Body/Area Scan (51x91x1): Measurement grid: dx=15mm, dy=15mm

[Info: Interpolated medium parameters used for SAR evaluation.](#)

Maximum value of SAR (interpolated) = 0.236 mW/g

Body/Zoom Scan (5x5x7) (5x5x7)/Cube 0: Measurement grid: dx=7.5mm, dy=7.5mm, dz=5mm

Reference Value = 7.28 V/m; Power Drift = -0.138 dB

Peak SAR (extrapolated) = 0.300 W/kg

SAR(1 g) = 0.219 mW/g; SAR(10 g) = 0.141 mW/g

[Info: Interpolated medium parameters used for SAR evaluation.](#)

Maximum value of SAR (measured) = 0.239 mW/g

	Document Appendix C for the BlackBerry® Smartphone Model RCX71UW SAR Report		Page 17(58)
	Author Data Andrew Becker	Dates of Test February 02 – March 03, 2010	Test Report No RTS-2474-1002-41

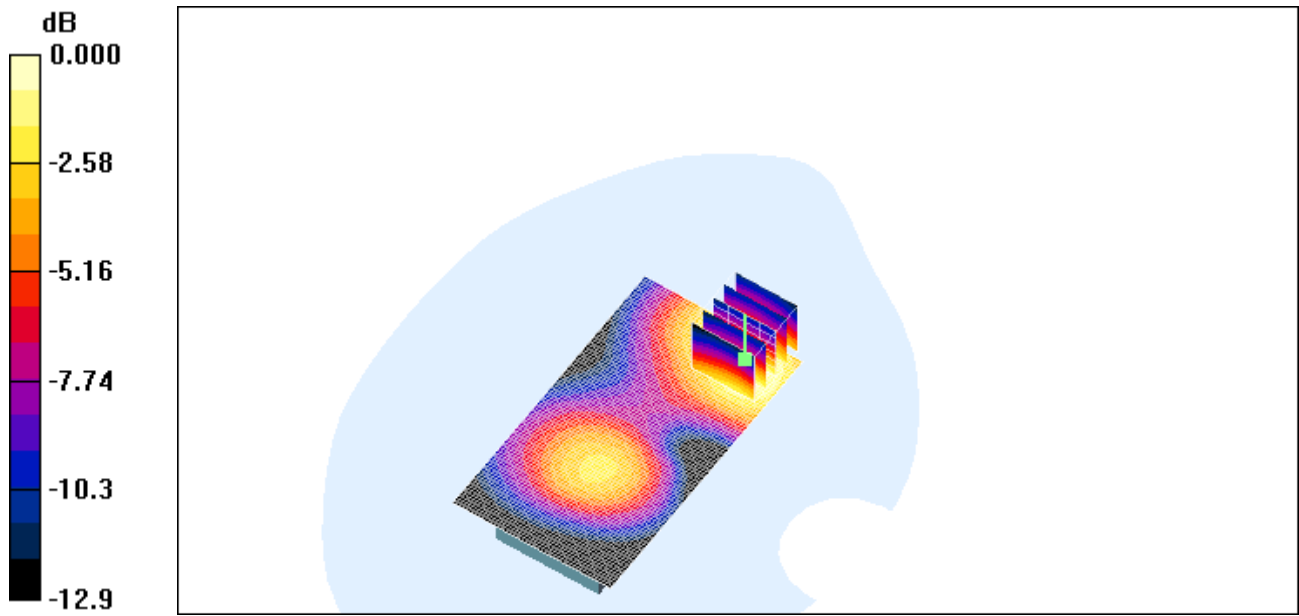

0 dB = 0.239mW/g

	Document		Page
	Appendix C for the BlackBerry® Smartphone Model RCX71UW SAR Report		18(58)
Author Data	Dates of Test	Test Report No	FCC ID:
Andrew Becker	February 02 – March 03, 2010	RTS-2474-1002-41	L6ARCX70UW

Date/Time: 11/02/2010 11:15:04 AM

Test Laboratory: RIM TESTING SERVICES

**Vertical_Holster_HS#1_Back_UMTS_Band_IV_mid_chan_amb_temp_23
.0C_liq_temp_21.9C**

DUT: BlackBerry Smartphone; Type: Sample ; Serial: 21D06A83

Communication System: WCDMA FDD IV; Frequency: 1732.6 MHz; Duty Cycle: 1:1
Medium parameters used (interpolated): $f = 1732.6$ MHz; $\sigma = 1.37$ mho/m; $\epsilon_r = 51.8$; $\rho = 1000$ kg/m³

Phantom section: Flat Section

Measurement Standard: DAS4 (High Precision Assessment)

DASY4 Configuration:

- Probe: ET3DV6 - SN1644; ConvF(4.69, 4.69, 4.69); Calibrated: 11/11/2009
- Sensor-Surface: 4mm (Mechanical Surface Detection)
- Electronics: DAE3 Sn472; Calibrated: 03/03/2009
- Phantom: SAM 2; Type: SAM 4.0; Serial: 1080
- Measurement SW: DAS4, V4.7 Build 80; Postprocessing SW: SEMCAD, V1.8 Build 186

Body/Area Scan (51x91x1): Measurement grid: dx=15mm, dy=15mm

[Info: Interpolated medium parameters used for SAR evaluation.](#)

Maximum value of SAR (interpolated) = 0.713 mW/g

Body/Zoom Scan (5x5x7) (5x5x7)/Cube 0: Measurement grid: dx=7.5mm, dy=7.5mm, dz=5mm

Reference Value = 6.85 V/m; Power Drift = -0.010 dB

Peak SAR (extrapolated) = 0.897 W/kg

SAR(1 g) = 0.655 mW/g; SAR(10 g) = 0.400 mW/g

[Info: Interpolated medium parameters used for SAR evaluation.](#)

Maximum value of SAR (measured) = 0.728 mW/g

	Document Appendix C for the BlackBerry® Smartphone Model RCX71UW SAR Report		Page 19(58)
	Author Data Andrew Becker	Dates of Test February 02 – March 03, 2010	Test Report No RTS-2474-1002-41

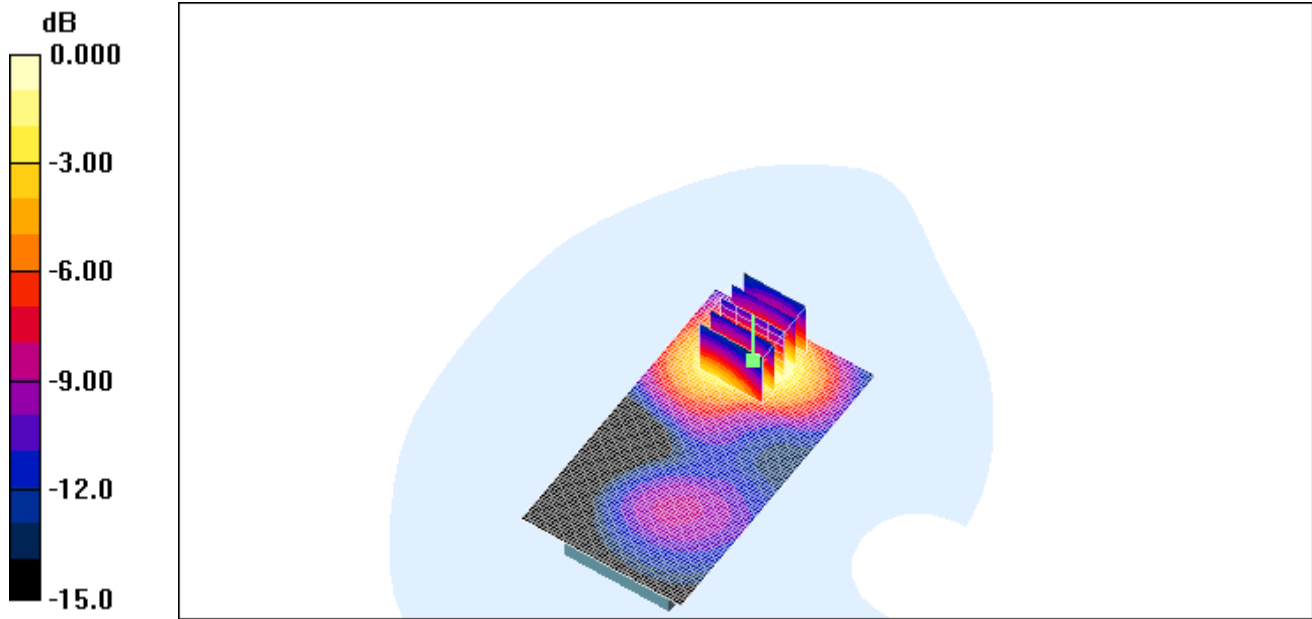

0 dB = 0.728mW/g

	Document		Page
	Appendix C for the BlackBerry® Smartphone Model RCX71UW SAR Report		20(58)
Author Data	Dates of Test	Test Report No	FCC ID:
Andrew Becker	February 02 – March 03, 2010	RTS-2474-1002-41	L6ARCX70UW

Date/Time: 11/02/2010 11:30:29 AM

Test Laboratory: RIM TESTING SERVICES

**Vertical_Holster_HS#2_Back_UMTS_Band_IV_mid_chan_amb_temp_22
.9C_liq_temp_21.7C**

DUT: BlackBerry Smartphone; Type: Sample ; Serial: 21D06A83

Communication System: WCDMA FDD IV; Frequency: 1732.6 MHz; Duty Cycle: 1:1
Medium parameters used (interpolated): $f = 1732.6$ MHz; $\sigma = 1.37$ mho/m; $\epsilon_r = 51.8$; $\rho = 1000$ kg/m³

Phantom section: Flat Section

Measurement Standard: DAS4 (High Precision Assessment)

DASY4 Configuration:

- Probe: ET3DV6 - SN1644; ConvF(4.69, 4.69, 4.69); Calibrated: 11/11/2009
- Sensor-Surface: 4mm (Mechanical Surface Detection)
- Electronics: DAE3 Sn472; Calibrated: 03/03/2009
- Phantom: SAM 2; Type: SAM 4.0; Serial: 1080
- Measurement SW: DAS4, V4.7 Build 80; Postprocessing SW: SEMCAD, V1.8 Build 186

Body/Area Scan (51x91x1): Measurement grid: dx=15mm, dy=15mm

[Info: Interpolated medium parameters used for SAR evaluation.](#)

Maximum value of SAR (interpolated) = 0.702 mW/g

Body/Zoom Scan (5x5x7) (5x5x7)/Cube 0: Measurement grid: dx=7.5mm, dy=7.5mm, dz=5mm

Reference Value = 7.06 V/m; Power Drift = -0.033 dB

Peak SAR (extrapolated) = 0.881 W/kg

SAR(1 g) = 0.644 mW/g; SAR(10 g) = 0.392 mW/g

[Info: Interpolated medium parameters used for SAR evaluation.](#)

Maximum value of SAR (measured) = 0.716 mW/g

	Document Appendix C for the BlackBerry® Smartphone Model RCX71UW SAR Report		Page 21(58)
	Author Data Andrew Becker	Dates of Test February 02 – March 03, 2010	Test Report No RTS-2474-1002-41

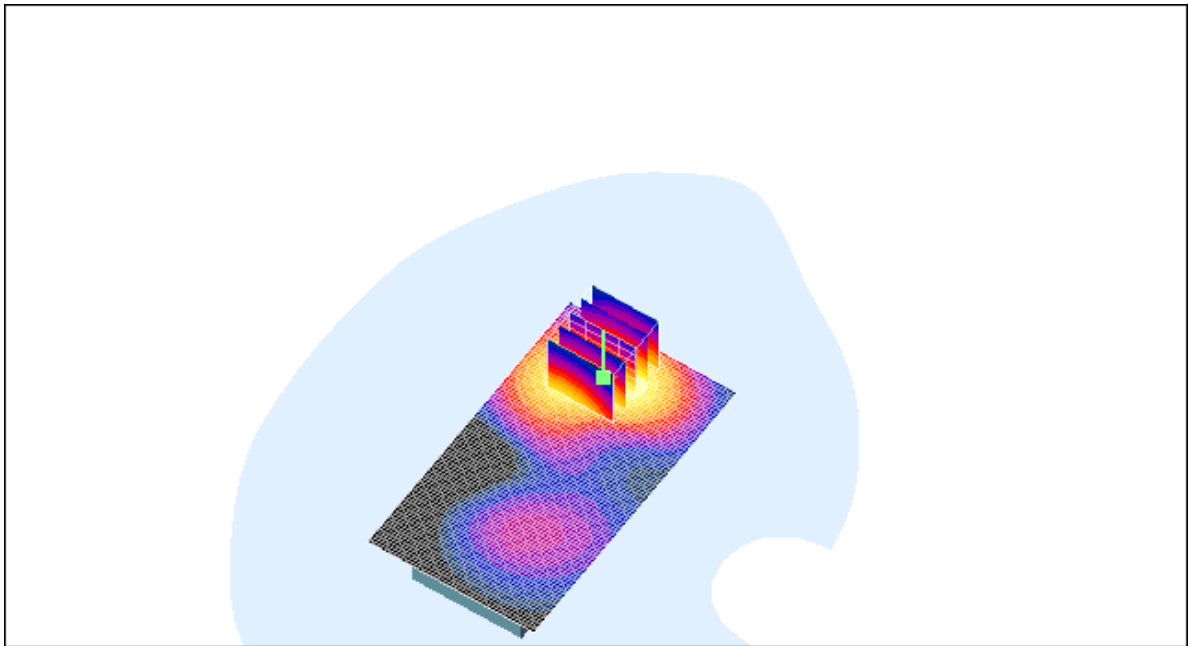
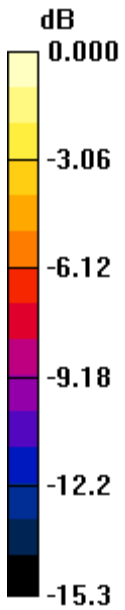

0 dB = 0.716mW/g

	Document		Page
	Appendix C for the BlackBerry® Smartphone Model RCX71UW SAR Report		22(58)
Author Data	Dates of Test	Test Report No	FCC ID:
Andrew Becker	February 02 – March 03, 2010	RTS-2474-1002-41	L6ARCX70UW

Date/Time: 11/02/2010 11:44:31 AM

Test Laboratory: RIM TESTING SERVICES

**Vertical_Holster_HS#3_Back_UMTS_Band_IV_mid_chan_amb_temp_22
.9C_liq_temp_21.6C**

DUT: BlackBerry Smartphone; Type: Sample ; Serial: 21D06A83

Communication System: WCDMA FDD IV; Frequency: 1732.6 MHz; Duty Cycle: 1:1
Medium parameters used (interpolated): $f = 1732.6$ MHz; $\sigma = 1.37$ mho/m; $\epsilon_r = 51.8$; $\rho = 1000$ kg/m³

Phantom section: Flat Section

Measurement Standard: DAS4 (High Precision Assessment)

DASY4 Configuration:

- Probe: ET3DV6 - SN1644; ConvF(4.69, 4.69, 4.69); Calibrated: 11/11/2009
- Sensor-Surface: 4mm (Mechanical Surface Detection)
- Electronics: DAE3 Sn472; Calibrated: 03/03/2009
- Phantom: SAM 2; Type: SAM 4.0; Serial: 1080
- Measurement SW: DAS4, V4.7 Build 80; Postprocessing SW: SEMCAD, V1.8 Build 186

Body/Area Scan (51x91x1): Measurement grid: dx=15mm, dy=15mm

[Info: Interpolated medium parameters used for SAR evaluation.](#)

Maximum value of SAR (interpolated) = 0.691 mW/g

Body/Zoom Scan (5x5x7) (5x5x7)/Cube 0: Measurement grid: dx=7.5mm, dy=7.5mm, dz=5mm

Reference Value = 6.77 V/m; Power Drift = -0.060 dB

Peak SAR (extrapolated) = 0.859 W/kg

SAR(1 g) = 0.629 mW/g; SAR(10 g) = 0.385 mW/g

[Info: Interpolated medium parameters used for SAR evaluation.](#)

Maximum value of SAR (measured) = 0.690 mW/g

	Document Appendix C for the BlackBerry® Smartphone Model RCX71UW SAR Report		Page 23(58)
	Author Data Andrew Becker	Dates of Test February 02 – March 03, 2010	Test Report No RTS-2474-1002-41

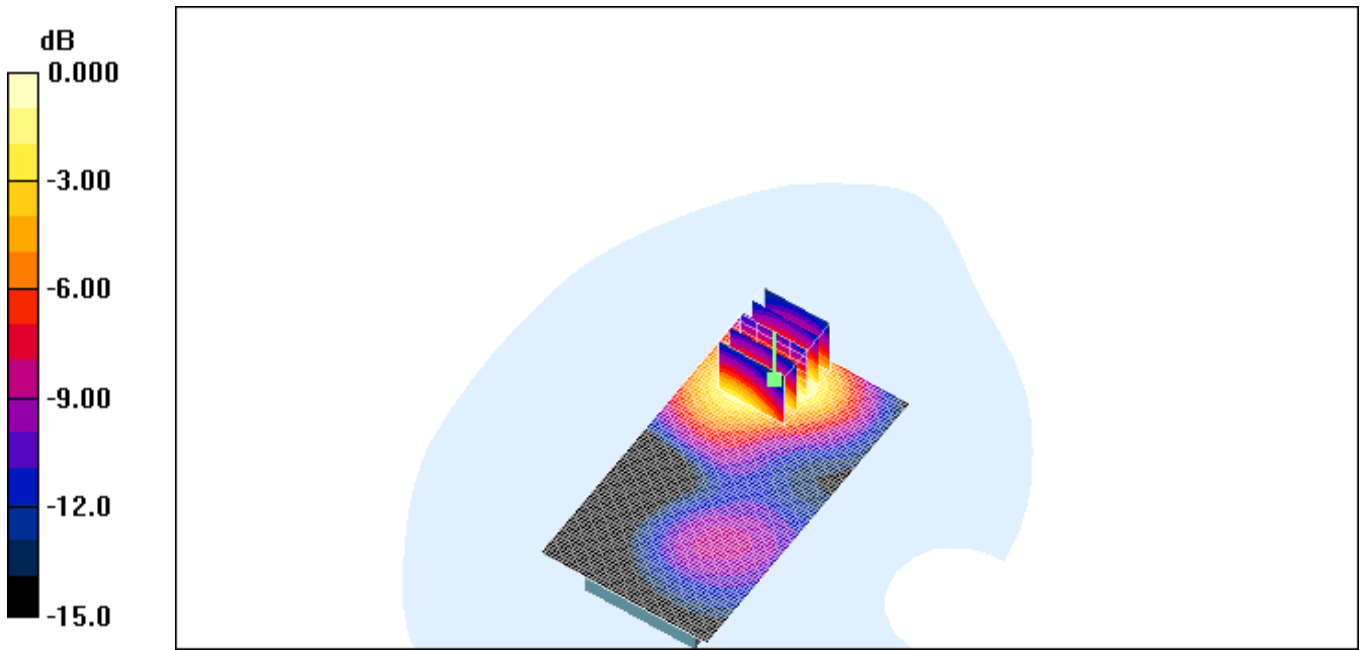

0 dB = 0.690mW/g

	Document		Page
	Appendix C for the BlackBerry® Smartphone Model RCX71UW SAR Report		24(58)
Author Data	Dates of Test	Test Report No	FCC ID:
Andrew Becker	February 02 – March 03, 2010	RTS-2474-1002-41	L6ARCX70UW

Date/Time: 11/02/2010 12:40:39 PM

Test Laboratory: RIM TESTING SERVICES

**25mm_Space_Back_UMTS_Band_IV_mid_chan_amb_temp_22.9C_liq_t
emp_21.5C**

DUT: BlackBerry Smartphone; Type: Sample ; Serial: 21D06A83

Communication System: WCDMA FDD IV; Frequency: 1732.6 MHz; Duty Cycle: 1:1
Medium parameters used (interpolated): $f = 1732.6$ MHz; $\sigma = 1.37$ mho/m; $\epsilon_r = 51.8$; $\rho = 1000$ kg/m³

Phantom section: Flat Section

Measurement Standard: DAS4 (High Precision Assessment)

DASY4 Configuration:

- Probe: ET3DV6 - SN1644; ConvF(4.69, 4.69, 4.69); Calibrated: 11/11/2009
- Sensor-Surface: 4mm (Mechanical Surface Detection)
- Electronics: DAE3 Sn472; Calibrated: 03/03/2009
- Phantom: SAM 2; Type: SAM 4.0; Serial: 1080
- Measurement SW: DAS4, V4.7 Build 80; Postprocessing SW: SEMCAD, V1.8 Build 186

Body/Area Scan (51x91x1): Measurement grid: dx=15mm, dy=15mm

[Info: Interpolated medium parameters used for SAR evaluation.](#)

Maximum value of SAR (interpolated) = 0.383 mW/g

Body/Zoom Scan (5x5x7) (5x5x7)/Cube 0: Measurement grid: dx=7.5mm, dy=7.5mm, dz=5mm

Reference Value = 4.36 V/m; Power Drift = 0.233 dB

Peak SAR (extrapolated) = 0.473 W/kg

SAR(1 g) = 0.350 mW/g; SAR(10 g) = 0.221 mW/g

[Info: Interpolated medium parameters used for SAR evaluation.](#)

Maximum value of SAR (measured) = 0.384 mW/g

	Document Appendix C for the BlackBerry® Smartphone Model RCX71UW SAR Report		Page 25(58)
	Author Data Andrew Becker	Dates of Test February 02 – March 03, 2010	Test Report No RTS-2474-1002-41

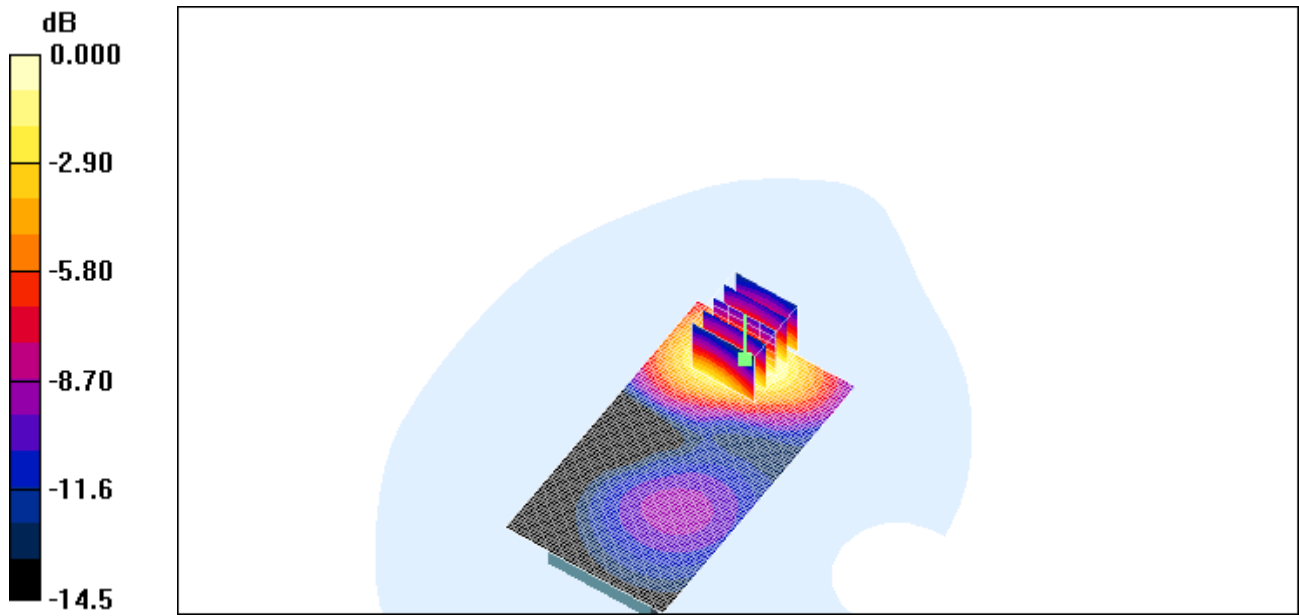

0 dB = 0.384mW/g

	Document		Page
	Appendix C for the BlackBerry® Smartphone Model RCX71UW SAR Report		26(58)
Author Data	Dates of Test	Test Report No	FCC ID:
Andrew Becker	February 02 – March 03, 2010	RTS-2474-1002-41	L6ARCX70UW

Date/Time: 12/02/2010 1:27:27 AM

Test Laboratory: RIM TESTING SERVICES

File Name:

[Vertical_Holster_Back_GPRS1900_mid_chan_amb_temp_23.2C_liq_temp_21.9C.da4](#)

DUT: BlackBerry Smartphone; Type: Sample ; Serial: 21D06A83

Program Name: Compliance Testing: (Body worn)

Communication System: GPRS 1900; Frequency: 1880 MHz; Duty Cycle: 1:4.2

Medium parameters used: $f = 1880$ MHz; $\sigma = 1.41$ mho/m; $\epsilon_r = 40.9$; $\rho = 1000$ kg/m³

Phantom section: Flat Section

DASY4 Configuration:

- Probe: ET3DV6 - SN1644; ConvF(5.17, 5.17, 5.17); Calibrated: 11/11/2009
- Sensor-Surface: 4mm (Mechanical Surface Detection)
- Electronics: DAE3 Sn472; Calibrated: 03/03/2009
- Phantom: SAM 2; Type: SAM 4.0; Serial: 1080
- Measurement SW: DASY4, V4.7 Build 80; Postprocessing SW: SEMCAD, V1.8 Build 186

Body/Area Scan (51x91x1): Measurement grid: dx=15mm, dy=15mm

Maximum value of SAR (interpolated) = 0.537 mW/g

Body/Zoom Scan (5x5x7) (5x5x7)/Cube 0: Measurement grid: dx=7.5mm, dy=7.5mm, dz=5mm

Reference Value = 6.01 V/m; Power Drift = -0.245 dB

Peak SAR (extrapolated) = 0.790 W/kg

SAR(1 g) = 0.485 mW/g; SAR(10 g) = 0.287 mW/g

Maximum value of SAR (measured) = 0.532 mW/g

	Document Appendix C for the BlackBerry® Smartphone Model RCX71UW SAR Report		Page 27(58)
	Author Data Andrew Becker	Dates of Test February 02 – March 03, 2010	Test Report No RTS-2474-1002-41

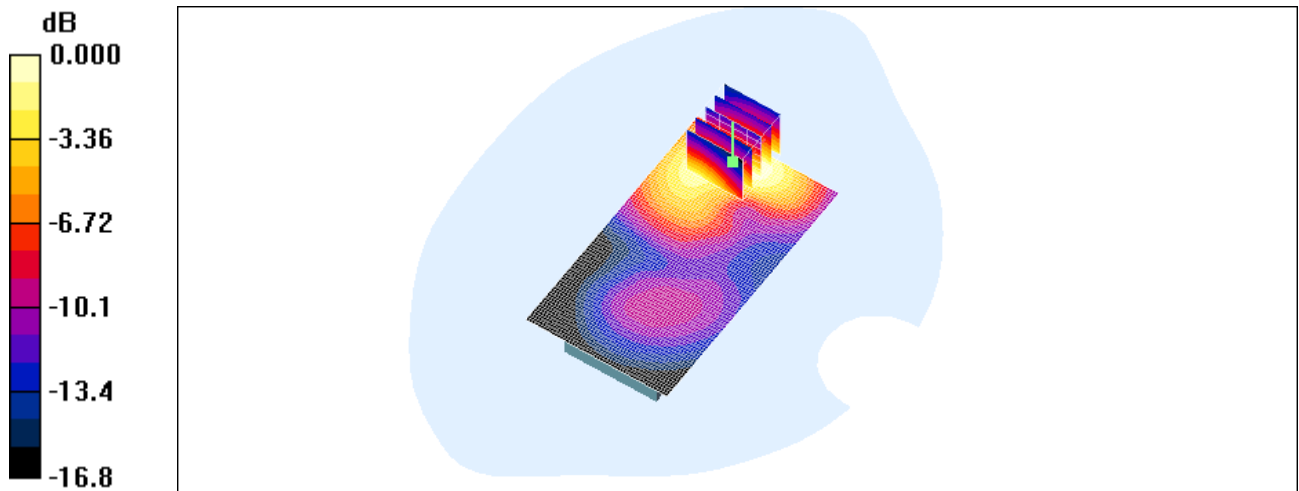

0 dB = 0.532mW/g

	Document		Page
	Appendix C for the BlackBerry® Smartphone Model RCX71UW SAR Report		28(58)
Author Data	Dates of Test	Test Report No	FCC ID:
Andrew Becker	February 02 – March 03, 2010	RTS-2474-1002-41	L6ARCX70UW

Date/Time: 12/02/2010 1:46:06 AM

Test Laboratory: RIM TESTING SERVICES

File Name:

[Vertical_Holster_Front_GPRS1900_mid_chan_amb_temp_23.2C_liq_temp_21.8C.da4](#)

DUT: BlackBerry Smartphone; Type: Sample ; Serial: 21D06A83

Program Name: Compliance Testing: (Body worn)

Communication System: GPRS 1900; Frequency: 1880 MHz; Duty Cycle: 1:4.2

Medium parameters used: $f = 1880$ MHz; $\sigma = 1.41$ mho/m; $\epsilon_r = 40.9$; $\rho = 1000$ kg/m³

Phantom section: Flat Section

DASY4 Configuration:

- Probe: ET3DV6 - SN1644; ConvF(5.17, 5.17, 5.17); Calibrated: 11/11/2009
- Sensor-Surface: 4mm (Mechanical Surface Detection)
- Electronics: DAE3 Sn472; Calibrated: 03/03/2009
- Phantom: SAM 2; Type: SAM 4.0; Serial: 1080
- Measurement SW: DASY4, V4.7 Build 80; Postprocessing SW: SEMCAD, V1.8 Build 186

Body/Area Scan (51x91x1): Measurement grid: dx=15mm, dy=15mm

Maximum value of SAR (interpolated) = 0.161 mW/g

Body/Zoom Scan (5x5x7) (5x5x7)/Cube 0: Measurement grid: dx=7.5mm, dy=7.5mm, dz=5mm

Reference Value = 4.79 V/m; Power Drift = 0.055 dB

Peak SAR (extrapolated) = 0.250 W/kg

SAR(1 g) = 0.149 mW/g; SAR(10 g) = 0.091 mW/g

Maximum value of SAR (measured) = 0.161 mW/g

	Document Appendix C for the BlackBerry® Smartphone Model RCX71UW SAR Report		Page 29(58)
	Author Data Andrew Becker	Dates of Test February 02 – March 03, 2010	Test Report No RTS-2474-1002-41

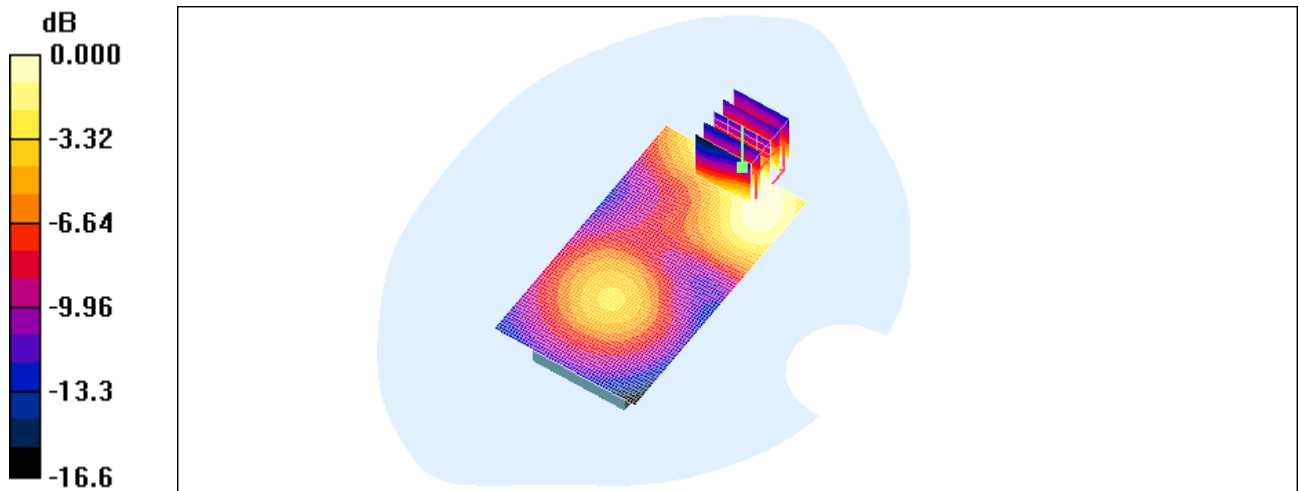

0 dB = 0.161mW/g

	Document		Page
	Appendix C for the BlackBerry® Smartphone Model RCX71UW SAR Report		30(58)
Author Data	Dates of Test	Test Report No	FCC ID:
Andrew Becker	February 02 – March 03, 2010	RTS-2474-1002-41	L6ARCX70UW

Date/Time: 12/02/2010 2:17:57 AM

Test Laboratory: RIM TESTING SERVICES

File Name:

[Vertical_Holster_HS#2_Back_GPRS1900_mid_chan_amb_temp_23.2C_liq_temp_21.8C.da4](#)

DUT: BlackBerry Smartphone; Type: Sample ; Serial: 21D06A83
Program Name: Compliance Testing: (Body worn)

Communication System: GPRS 1900; Frequency: 1880 MHz; Duty Cycle: 1:4.2
Medium parameters used: $f = 1880 \text{ MHz}$; $\sigma = 1.41 \text{ mho/m}$; $\epsilon_r = 40.9$; $\rho = 1000 \text{ kg/m}^3$
Phantom section: Flat Section

DASY4 Configuration:

- Probe: ET3DV6 - SN1644; ConvF(5.17, 5.17, 5.17); Calibrated: 11/11/2009
- Sensor-Surface: 4mm (Mechanical Surface Detection)
- Electronics: DAE3 Sn472; Calibrated: 03/03/2009
- Phantom: SAM 2; Type: SAM 4.0; Serial: 1080
- Measurement SW: DASY4, V4.7 Build 80; Postprocessing SW: SEMCAD, V1.8 Build 186

Body/Area Scan (51x91x1): Measurement grid: dx=15mm, dy=15mm
Maximum value of SAR (interpolated) = 0.557 mW/g

Body/Zoom Scan (5x5x7) (5x5x7)/Cube 0: Measurement grid: dx=7.5mm, dy=7.5mm, dz=5mm
Reference Value = 6.80 V/m; Power Drift = -0.054 dB
Peak SAR (extrapolated) = 0.828 W/kg
SAR(1 g) = 0.505 mW/g; SAR(10 g) = 0.295 mW/g
Maximum value of SAR (measured) = 0.554 mW/g

	Document Appendix C for the BlackBerry® Smartphone Model RCX71UW SAR Report		Page 31(58)
	Author Data Andrew Becker	Dates of Test February 02 – March 03, 2010	Test Report No RTS-2474-1002-41

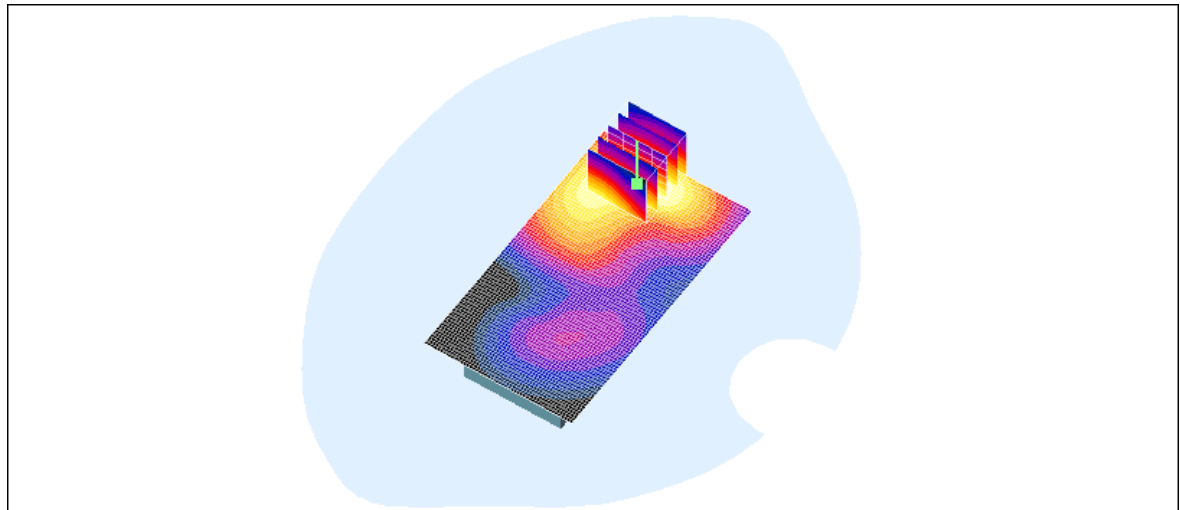
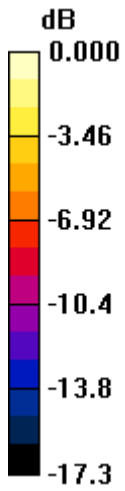

0 dB = 0.554mW/g

	Document		Page
	Appendix C for the BlackBerry® Smartphone Model RCX71UW SAR Report		32(58)
Author Data	Dates of Test	Test Report No	FCC ID:
Andrew Becker	February 02 – March 03, 2010	RTS-2474-1002-41	L6ARCX70UW

Date/Time: 12/02/2010 2:34:07 AM

Test Laboratory: RIM TESTING SERVICES

File Name:

[25mm Spacer GPRS1900_mid_chan_amb_temp_23.2C_liq_temp_21.8C.da4](#)

DUT: BlackBerry Smartphone; Type: Sample ; Serial: 21D06A83

Program Name: Compliance Testing: (Body worn)

Communication System: GPRS 1900; Frequency: 1880 MHz; Duty Cycle: 1:4.2

Medium parameters used: $f = 1880$ MHz; $\sigma = 1.41$ mho/m; $\epsilon_r = 40.9$; $\rho = 1000$ kg/m³

Phantom section: Flat Section

DASY4 Configuration:

- Probe: ET3DV6 - SN1644; ConvF(5.17, 5.17, 5.17); Calibrated: 11/11/2009
- Sensor-Surface: 4mm (Mechanical Surface Detection)
- Electronics: DAE3 Sn472; Calibrated: 03/03/2009
- Phantom: SAM 2; Type: SAM 4.0; Serial: 1080
- Measurement SW: DASY4, V4.7 Build 80; Postprocessing SW: SEMCAD, V1.8 Build 186

Body/Area Scan (51x91x1): Measurement grid: dx=15mm, dy=15mm

Maximum value of SAR (interpolated) = 0.254 mW/g

Body/Zoom Scan (5x5x7) (5x5x7)/Cube 0: Measurement grid: dx=7.5mm, dy=7.5mm, dz=5mm

Reference Value = 4.65 V/m; Power Drift = -0.016 dB

Peak SAR (extrapolated) = 0.381 W/kg

SAR(1 g) = 0.234 mW/g; SAR(10 g) = 0.141 mW/g

Maximum value of SAR (measured) = 0.254 mW/g

	Document Appendix C for the BlackBerry® Smartphone Model RCX71UW SAR Report		Page 33(58)
	Author Data Andrew Becker	Dates of Test February 02 – March 03, 2010	Test Report No RTS-2474-1002-41

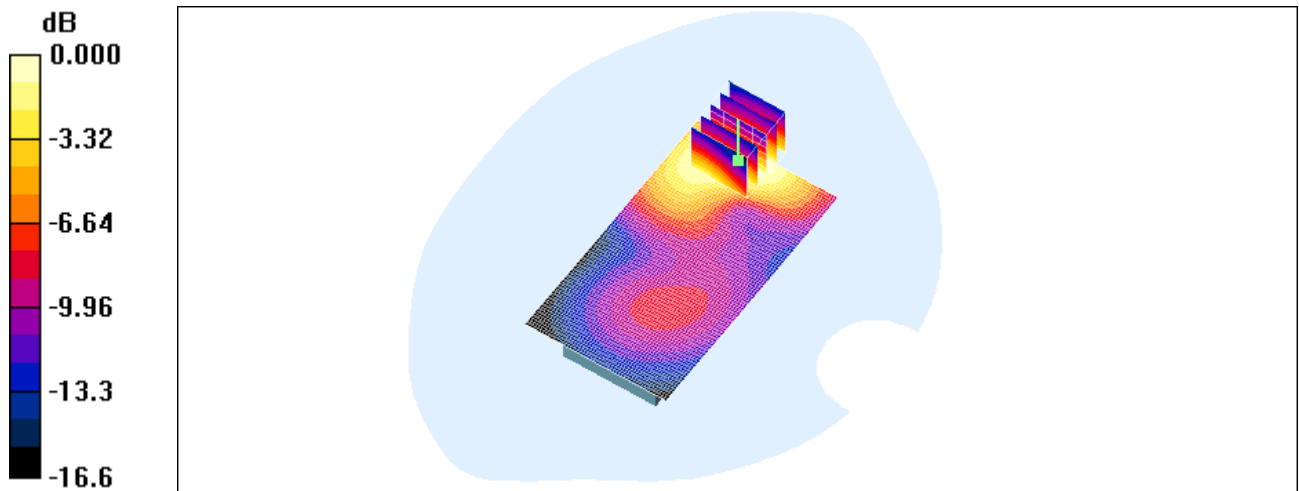

0 dB = 0.254mW/g

	Document		Page
	Appendix C for the BlackBerry® Smartphone Model RCX71UW SAR Report		34(58)
Author Data	Dates of Test	Test Report No	FCC ID:
Andrew Becker	February 02 – March 03, 2010	RTS-2474-1002-41	L6ARCX70UW

Date/Time: 02/02/2010 11:19:03 PM

Test Laboratory: RIM TESTING SERVICES

File Name:

[Vertical_Holster_Back_bluetooth_low_chan_amb_temp_23.2C_liq_temp_21.2C.da4](#)

DUT: BlackBerry Smartphone; Type: Sample ; Serial: 21BE0648

Program Name: Compliance Testing: (Body worn)

Communication System: Bluetooth; Frequency: 2402 MHz; Duty Cycle: 1:1

Medium parameters used (interpolated): $f = 2402$ MHz; $\sigma = 1.91$ mho/m; $\epsilon_r = 50.7$; $\rho = 1000$ kg/m³

Phantom section: Flat Section

DASY4 Configuration:

- Probe: ET3DV6 - SN1644; ConvF(4.11, 4.11, 4.11); Calibrated: 11/11/2009
- Sensor-Surface: 4mm (Mechanical Surface Detection)
- Electronics: DAE3 Sn472; Calibrated: 03/03/2009
- Phantom: SAM 2; Type: SAM 4.0; Serial: 1080
- Measurement SW: DASY4, V4.7 Build 80; Postprocessing SW: SEMCAD, V1.8 Build 186

Body/Area Scan (51x91x1): Measurement grid: dx=15mm, dy=15mm

[Info: Interpolated medium parameters used for SAR evaluation.](#)

Maximum value of SAR (interpolated) = 0.011 mW/g

Body/Zoom Scan (5x5x7) (5x5x7)/Cube 0: Measurement grid: dx=7.5mm, dy=7.5mm, dz=5mm

Reference Value = 1.96 V/m; Power Drift = 0.123 dB

Peak SAR (extrapolated) = 0.055 W/kg

SAR(1 g) = 0.00971 mW/g; SAR(10 g) = 0.00135 mW/g

[Info: Interpolated medium parameters used for SAR evaluation.](#)

Maximum value of SAR (measured) = 0.013 mW/g

	Document Appendix C for the BlackBerry® Smartphone Model RCX71UW SAR Report		Page 35(58)
	Author Data Andrew Becker	Dates of Test February 02 – March 03, 2010	Test Report No RTS-2474-1002-41

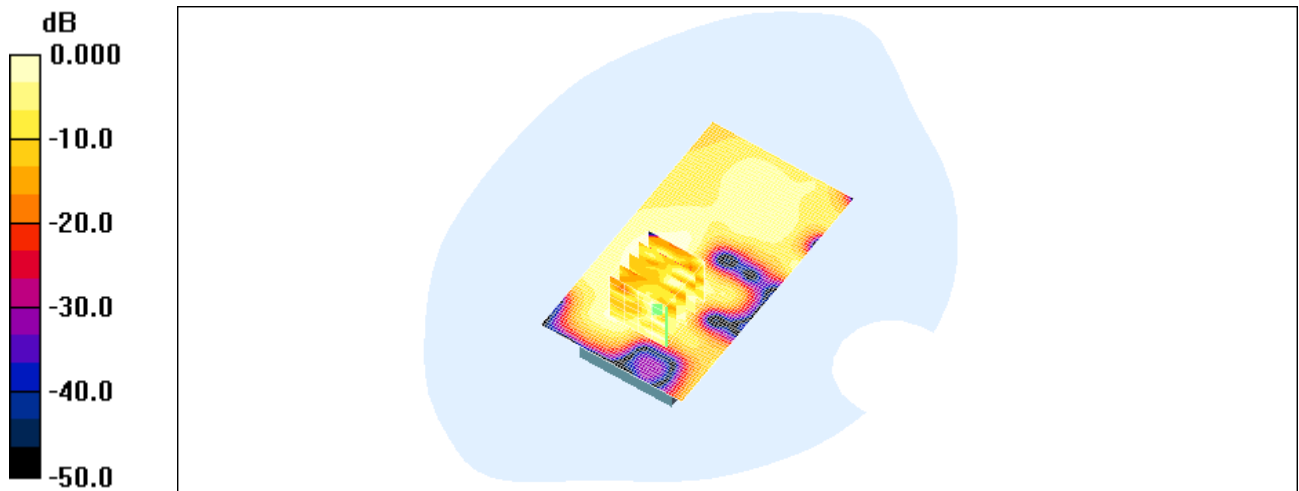

0 dB = 0.013mW/g

	Document		Page
	Appendix C for the BlackBerry® Smartphone Model RCX71UW SAR Report		36(58)
Author Data	Dates of Test	Test Report No	FCC ID:
Andrew Becker	February 02 – March 03, 2010	RTS-2474-1002-41	L6ARCX70UW

Date/Time: 02/02/2010 11:35:54 PM

Test Laboratory: RIM TESTING SERVICES

File Name:

[Vertical_Holster_Front_bluetooth_low_chan_amb_temp_23.4C_liq_temp_21.4C.da4](#)

DUT: BlackBerry Smartphone; Type: Sample ; Serial: 21BE0648

Program Name: Compliance Testing: (Body worn)

Communication System: Bluetooth; Frequency: 2402 MHz; Duty Cycle: 1:1

Medium parameters used (interpolated): $f = 2402$ MHz; $\sigma = 1.91$ mho/m; $\epsilon_r = 50.7$; $\rho = 1000$ kg/m³

Phantom section: Flat Section

DASY4 Configuration:

- Probe: ET3DV6 - SN1644; ConvF(4.11, 4.11, 4.11); Calibrated: 11/11/2009
- Sensor-Surface: 4mm (Mechanical Surface Detection)
- Electronics: DAE3 Sn472; Calibrated: 03/03/2009
- Phantom: SAM 2; Type: SAM 4.0; Serial: 1080
- Measurement SW: DASY4, V4.7 Build 80; Postprocessing SW: SEMCAD, V1.8 Build 186

Body/Area Scan (51x91x1): Measurement grid: dx=15mm, dy=15mm

[Info: Interpolated medium parameters used for SAR evaluation.](#)

Maximum value of SAR (interpolated) = 0.008 mW/g

Body/Zoom Scan (5x5x7) (5x5x7)/Cube 0: Measurement grid: dx=7.5mm, dy=7.5mm, dz=5mm

Reference Value = 0.742 V/m; Power Drift = 0.600 dB

Peak SAR (extrapolated) = 0.012 W/kg

SAR(1 g) = 2.78e-005 mW/g; SAR(10 g) = 5.05e-006 mW/g

[Info: Interpolated medium parameters used for SAR evaluation.](#)

Maximum value of SAR (measured) = 0.012 mW/g

	Document Appendix C for the BlackBerry® Smartphone Model RCX71UW SAR Report		Page 37(58)
	Author Data Andrew Becker	Dates of Test February 02 – March 03, 2010	Test Report No RTS-2474-1002-41

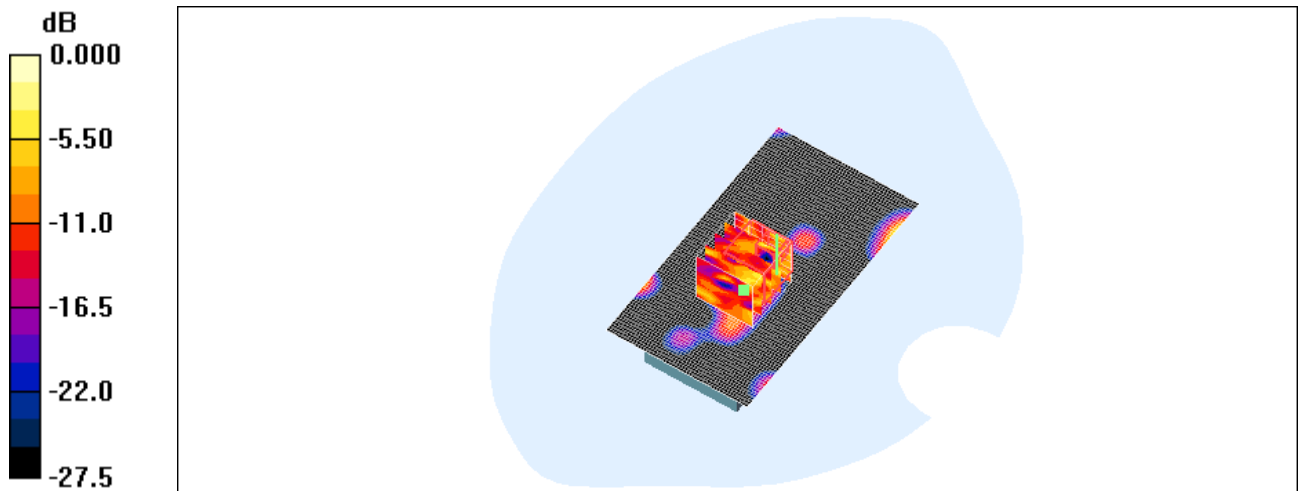

0 dB = 0.012mW/g

	Document		Page
	Appendix C for the BlackBerry® Smartphone Model RCX71UW SAR Report		38(58)
Author Data	Dates of Test	Test Report No	FCC ID:
Andrew Becker	February 02 – March 03, 2010	RTS-2474-1002-41	L6ARCX70UW

Date/Time: 02/02/2010 11:52:48 PM

Test Laboratory: RIM TESTING SERVICES

File Name:

[Vertical_Holster_Back_Headset1_bluetooth_low_chan_amb_temp_23.3C_liq_temp_21.3C.da4](#)

DUT: BlackBerry Smartphone; Type: Sample ; Serial: 21BE0648

Program Name: Compliance Testing: (Body worn)

Communication System: Bluetooth; Frequency: 2402 MHz; Duty Cycle: 1:1
Medium parameters used (interpolated): $f = 2402 \text{ MHz}$; $\sigma = 1.91 \text{ mho/m}$; $\epsilon_r = 50.7$; $\rho = 1000 \text{ kg/m}^3$

Phantom section: Flat Section

DASY4 Configuration:

- Probe: ET3DV6 - SN1644; ConvF(4.11, 4.11, 4.11); Calibrated: 11/11/2009
- Sensor-Surface: 4mm (Mechanical Surface Detection)
- Electronics: DAE3 Sn472; Calibrated: 03/03/2009
- Phantom: SAM 2; Type: SAM 4.0; Serial: 1080
- Measurement SW: DASY4, V4.7 Build 80; Postprocessing SW: SEMCAD, V1.8 Build 186

Body/Area Scan (51x91x1): Measurement grid: dx=15mm, dy=15mm

[Info: Interpolated medium parameters used for SAR evaluation.](#)

Maximum value of SAR (interpolated) = 0.010 mW/g

Body/Zoom Scan (5x5x7) (5x5x7)/Cube 0: Measurement grid: dx=7.5mm, dy=7.5mm, dz=5mm

Reference Value = 2.28 V/m; Power Drift = -0.138 dB

Peak SAR (extrapolated) = 0.030 W/kg

SAR(1 g) = 0.00987 mW/g; SAR(10 g) = 0.00481 mW/g

[Info: Interpolated medium parameters used for SAR evaluation.](#)

Maximum value of SAR (measured) = 0.011 mW/g

	Document Appendix C for the BlackBerry® Smartphone Model RCX71UW SAR Report		Page 39(58)
	Author Data Andrew Becker	Dates of Test February 02 – March 03, 2010	Test Report No RTS-2474-1002-41

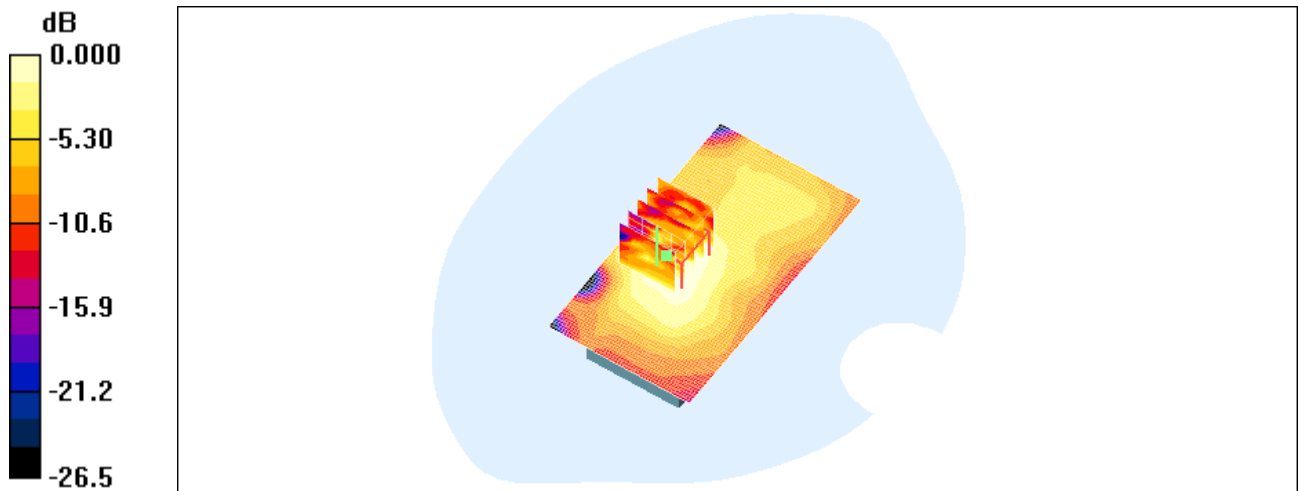

0 dB = 0.011mW/g

	Document		Page
	Appendix C for the BlackBerry® Smartphone Model RCX71UW SAR Report		40(58)
Author Data	Dates of Test	Test Report No	FCC ID:
Andrew Becker	February 02 – March 03, 2010	RTS-2474-1002-41	L6ARCX70UW

Date/Time: 03/02/2010 12:09:12 AM

Test Laboratory: RIM TESTING SERVICES

File Name:

[Vertical_Holster_Back_Headset2_bluetooth_low_chan_amb_temp_23.3C_liq_temp_21.3C.da4](#)

DUT: BlackBerry Smartphone; Type: Sample ; Serial: 21BE0648

Program Name: Compliance Testing: (Body worn)

Communication System: Bluetooth; Frequency: 2402 MHz; Duty Cycle: 1:1
Medium parameters used (interpolated): $f = 2402 \text{ MHz}$; $\sigma = 1.91 \text{ mho/m}$; $\epsilon_r = 50.7$; $\rho = 1000 \text{ kg/m}^3$

Phantom section: Flat Section

DASY4 Configuration:

- Probe: ET3DV6 - SN1644; ConvF(4.11, 4.11, 4.11); Calibrated: 11/11/2009
- Sensor-Surface: 4mm (Mechanical Surface Detection)
- Electronics: DAE3 Sn472; Calibrated: 03/03/2009
- Phantom: SAM 2; Type: SAM 4.0; Serial: 1080
- Measurement SW: DASY4, V4.7 Build 80; Postprocessing SW: SEMCAD, V1.8 Build 186

Body/Area Scan (51x91x1): Measurement grid: dx=15mm, dy=15mm

[Info: Interpolated medium parameters used for SAR evaluation.](#)

Maximum value of SAR (interpolated) = 0.011 mW/g

Body/Zoom Scan (5x5x7) (5x5x7)/Cube 0: Measurement grid: dx=7.5mm, dy=7.5mm, dz=5mm

Reference Value = 2.18 V/m; Power Drift = 0.586 dB

Peak SAR (extrapolated) = 0.039 W/kg

SAR(1 g) = 0.011 mW/g; SAR(10 g) = 0.00501 mW/g

[Info: Interpolated medium parameters used for SAR evaluation.](#)

Maximum value of SAR (measured) = 0.011 mW/g

	Document Appendix C for the BlackBerry® Smartphone Model RCX71UW SAR Report		Page 41(58)
	Author Data Andrew Becker	Dates of Test February 02 – March 03, 2010	Test Report No RTS-2474-1002-41

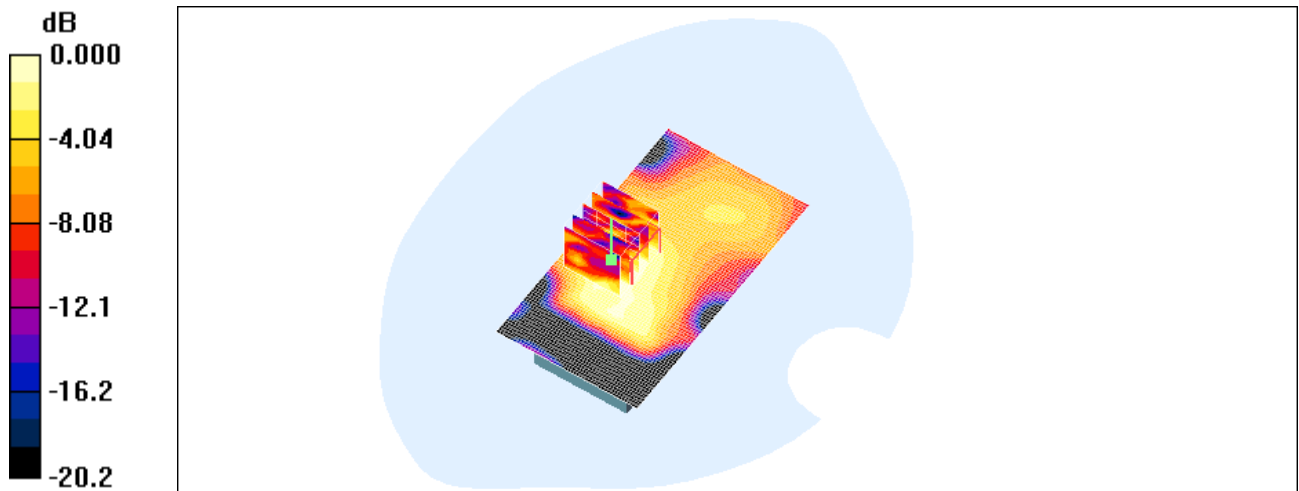

0 dB = 0.011mW/g

	Document		Page
	Appendix C for the BlackBerry® Smartphone Model RCX71UW SAR Report		42(58)
Author Data	Dates of Test	Test Report No	FCC ID:
Andrew Becker	February 02 – March 03, 2010	RTS-2474-1002-41	L6ARCX70UW

Date/Time: 03/02/2010 12:23:38 AM

Test Laboratory: RIM TESTING SERVICES

File Name:

[Vertical_Holster_Back_Headset3_bluetooth_low_chan_amb_temp_23.3C_liq_temp_21.3C.da4](#)

DUT: BlackBerry Smartphone; Type: Sample ; Serial: 21BE0648
Program Name: Compliance Testing: (Body worn)

Communication System: Bluetooth; Frequency: 2402 MHz; Duty Cycle: 1:1
Medium parameters used (interpolated): $f = 2402$ MHz; $\sigma = 1.91$ mho/m; $\epsilon_r = 50.7$; $\rho = 1000$ kg/m³
Phantom section: Flat Section

DASY4 Configuration:

- Probe: ET3DV6 - SN1644; ConvF(4.11, 4.11, 4.11); Calibrated: 11/11/2009
- Sensor-Surface: 4mm (Mechanical Surface Detection)
- Electronics: DAE3 Sn472; Calibrated: 03/03/2009
- Phantom: SAM 2; Type: SAM 4.0; Serial: 1080
- Measurement SW: DASY4, V4.7 Build 80; Postprocessing SW: SEMCAD, V1.8 Build 186

Body/Area Scan (51x91x1): Measurement grid: dx=15mm, dy=15mm

[Info: Interpolated medium parameters used for SAR evaluation.](#)

Maximum value of SAR (interpolated) = 0.011 mW/g

Body/Zoom Scan (5x5x7) (5x5x7)/Cube 0: Measurement grid: dx=7.5mm, dy=7.5mm, dz=5mm

Reference Value = 2.36 V/m; Power Drift = 0.063 dB

Peak SAR (extrapolated) = 0.041 W/kg

SAR(1 g) = 0.011 mW/g; SAR(10 g) = 0.00469 mW/g

[Info: Interpolated medium parameters used for SAR evaluation.](#)

Maximum value of SAR (measured) = 0.011 mW/g

	Document Appendix C for the BlackBerry® Smartphone Model RCX71UW SAR Report		Page 43(58)
	Author Data Andrew Becker	Dates of Test February 02 – March 03, 2010	Test Report No RTS-2474-1002-41

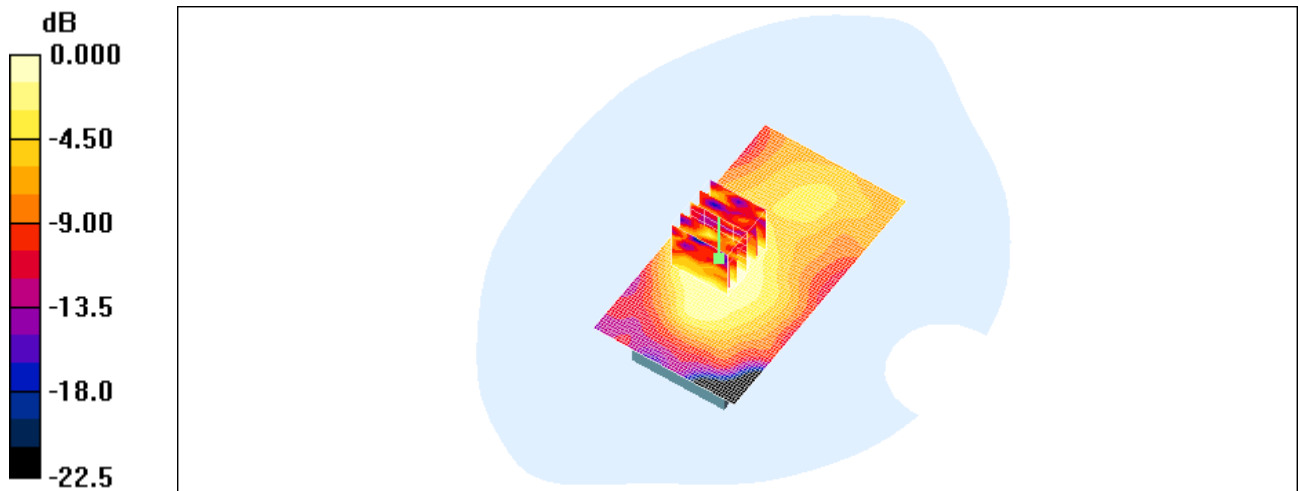

0 dB = 0.011mW/g

	Document		Page
	Appendix C for the BlackBerry® Smartphone Model RCX71UW SAR Report		44(58)
Author Data	Dates of Test	Test Report No	FCC ID:
Andrew Becker	February 02 – March 03, 2010	RTS-2474-1002-41	L6ARCX70UW

Date/Time: 03/02/2010 12:39:07 AM

Test Laboratory: RIM TESTING SERVICES

File Name: [25mm Spacer bluetooth low chan amb temp 23.3C liq temp 21.3C.da4](#)

DUT: BlackBerry Smartphone; Type: Sample ; Serial: 21BE0648
Program Name: Compliance Testing: (Body worn)

Communication System: Bluetooth; Frequency: 2402 MHz; Duty Cycle: 1:1
Medium parameters used (interpolated): $f = 2402$ MHz; $\sigma = 1.91$ mho/m; $\epsilon_r = 50.7$; $\rho = 1000$ kg/m³
Phantom section: Flat Section

DASY4 Configuration:

- Probe: ET3DV6 - SN1644; ConvF(4.11, 4.11, 4.11); Calibrated: 11/11/2009
- Sensor-Surface: 4mm (Mechanical Surface Detection)
- Electronics: DAE3 Sn472; Calibrated: 03/03/2009
- Phantom: SAM 2; Type: SAM 4.0; Serial: 1080
- Measurement SW: DASY4, V4.7 Build 80; Postprocessing SW: SEMCAD, V1.8 Build 186

Body/Area Scan (51x91x1): Measurement grid: dx=15mm, dy=15mm

[Info: Interpolated medium parameters used for SAR evaluation.](#)

Maximum value of SAR (interpolated) = 0.006 mW/g

Body/Zoom Scan (5x5x7) (5x5x7)/Cube 0: Measurement grid: dx=7.5mm, dy=7.5mm, dz=5mm

Reference Value = 1.55 V/m; Power Drift = 1.70 dB

Peak SAR (extrapolated) = 0.005 W/kg

SAR(1 g) = 0.000145 mW/g; SAR(10 g) = 2.88e-005 mW/g

[Info: Interpolated medium parameters used for SAR evaluation.](#)

Maximum value of SAR (measured) = 0.006 mW/g

	Document Appendix C for the BlackBerry® Smartphone Model RCX71UW SAR Report		Page 45(58)
	Author Data Andrew Becker	Dates of Test February 02 – March 03, 2010	Test Report No RTS-2474-1002-41

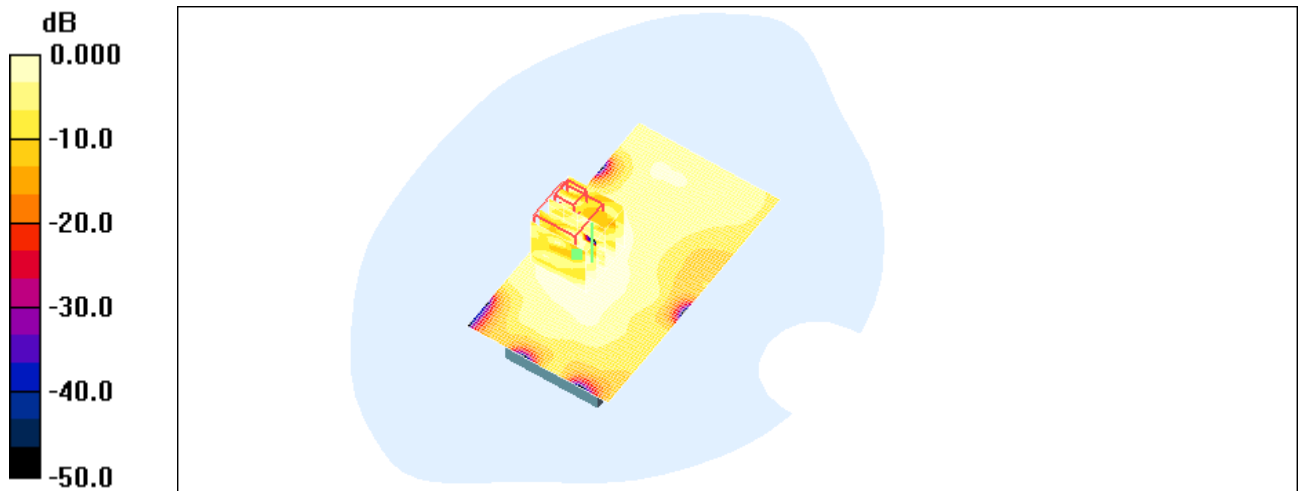

0 dB = 0.006mW/g

	Document		Page
	Appendix C for the BlackBerry® Smartphone Model RCX71UW SAR Report		46(58)
Author Data	Dates of Test	Test Report No	FCC ID:
Andrew Becker	February 02 – March 03, 2010	RTS-2474-1002-41	L6ARCX70UW

Date/Time: 2/25/2010 11:03:19 PM

Test Laboratory: RIM TESTING SERVICES

File Name:

[Vertical_Holster_Back_802.11b_low_chan_amb_temp_23.9C_liq_temp_21.8C.da4](#)

DUT: BlackBerry Smartphone; Type: Sample ; Serial: 21D06A83

Program Name: Compliance Testing: (Body worn)

Communication System: 802.11 b (2450); Frequency: 2412 MHz; Duty Cycle: 1:1
Medium parameters used (interpolated): $f = 2412$ MHz; $\sigma = 1.95$ mho/m; $\epsilon_r = 50.5$; $\rho = 1000$ kg/m³

Phantom section: Flat Section

DASY4 Configuration:

- Probe: ET3DV6 - SN1644; ConvF(4.11, 4.11, 4.11); Calibrated: 11/11/2009
- Sensor-Surface: 4mm (Mechanical Surface Detection)
- Electronics: DAE3 Sn473; Calibrated: 1/4/2010
- Phantom: SAM 2; Type: SAM 4.0; Serial: 1080
- Measurement SW: DASY4, V4.7 Build 80; Postprocessing SW: SEMCAD, V1.8 Build 186

Body/Area Scan (51x91x1): Measurement grid: dx=15mm, dy=15mm

[Info: Interpolated medium parameters used for SAR evaluation.](#)

Maximum value of SAR (interpolated) = 0.277 mW/g

Body/Zoom Scan (5x5x7) (5x5x7)/Cube 0: Measurement grid: dx=7.5mm, dy=7.5mm, dz=5mm

Reference Value = 7.39 V/m; Power Drift = -0.088 dB

Peak SAR (extrapolated) = 0.580 W/kg

SAR(1 g) = 0.270 mW/g; SAR(10 g) = 0.145 mW/g

[Info: Interpolated medium parameters used for SAR evaluation.](#)

Maximum value of SAR (measured) = 0.283 mW/g

	Document Appendix C for the BlackBerry® Smartphone Model RCX71UW SAR Report		Page 47(58)
	Author Data Andrew Becker	Dates of Test February 02 – March 03, 2010	Test Report No RTS-2474-1002-41

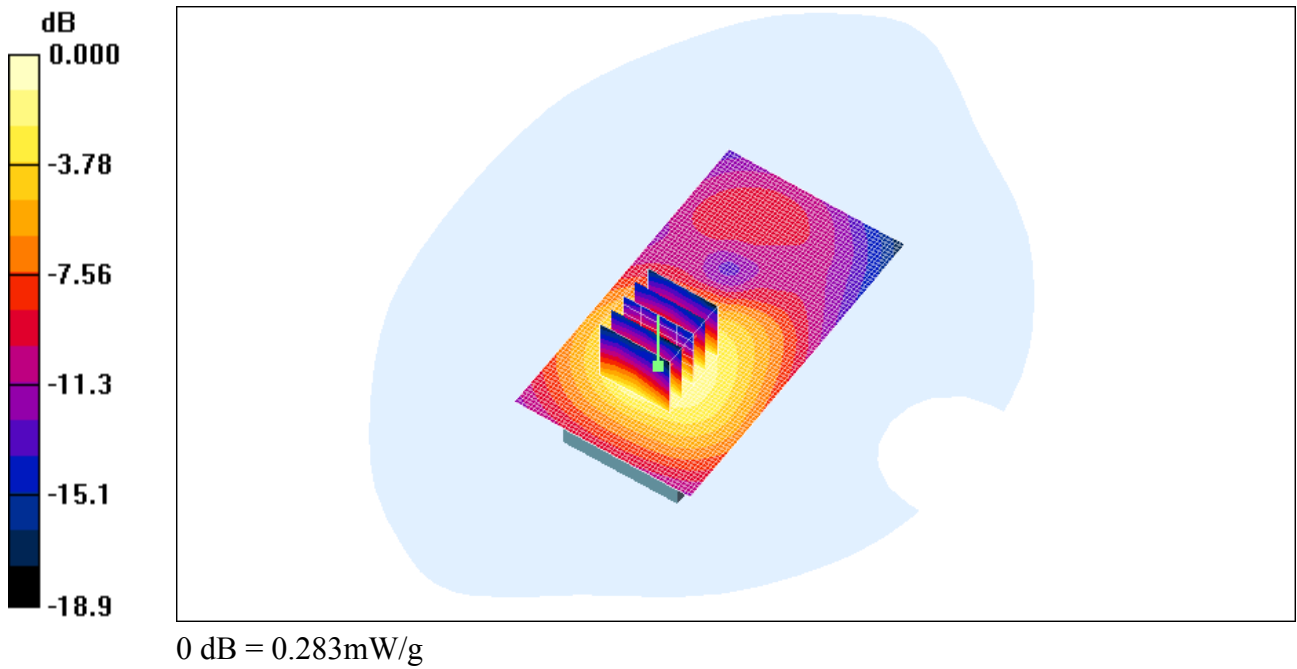

	Document		Page
	Appendix C for the BlackBerry® Smartphone Model RCX71UW SAR Report		48(58)
Author Data	Dates of Test	Test Report No	FCC ID:
Andrew Becker	February 02 – March 03, 2010	RTS-2474-1002-41	L6ARCX70UW

Date/Time: 2/26/2010 12:14:42 AM

Test Laboratory: RIM TESTING SERVICES

File Name:

[Vertical_Holster_Back_802.11b_mid_chan_amb_temp_23.5C_liq_temp_21.4C.da4](#)

DUT: BlackBerry Smartphone; Type: Sample ; Serial: 21D06A83

Program Name: Compliance Testing: (Body worn)

Communication System: 802.11 b (2450); Frequency: 2437 MHz; Duty Cycle: 1:1
Medium parameters used (interpolated): $f = 2437$ MHz; $\sigma = 1.92$ mho/m; $\epsilon_r = 50.2$; $\rho = 1000$ kg/m³

Phantom section: Flat Section

DASY4 Configuration:

- Probe: ET3DV6 - SN1644; ConvF(4.11, 4.11, 4.11); Calibrated: 11/11/2009
- Sensor-Surface: 4mm (Mechanical Surface Detection)
- Electronics: DAE3 Sn473; Calibrated: 1/4/2010
- Phantom: SAM 2; Type: SAM 4.0; Serial: 1080
- Measurement SW: DASY4, V4.7 Build 80; Postprocessing SW: SEMCAD, V1.8 Build 186

Body/Area Scan (51x91x1): Measurement grid: dx=15mm, dy=15mm

[Info: Interpolated medium parameters used for SAR evaluation.](#)

Maximum value of SAR (interpolated) = 0.200 mW/g

Body/Zoom Scan (5x5x7) (5x5x7)/Cube 0: Measurement grid: dx=7.5mm, dy=7.5mm, dz=5mm

Reference Value = 6.58 V/m; Power Drift = -0.247 dB

Peak SAR (extrapolated) = 0.429 W/kg

SAR(1 g) = 0.199 mW/g; SAR(10 g) = 0.105 mW/g

[Info: Interpolated medium parameters used for SAR evaluation.](#)

Maximum value of SAR (measured) = 0.208 mW/g

	Document Appendix C for the BlackBerry® Smartphone Model RCX71UW SAR Report		Page 49(58)
	Author Data Andrew Becker	Dates of Test February 02 – March 03, 2010	Test Report No RTS-2474-1002-41

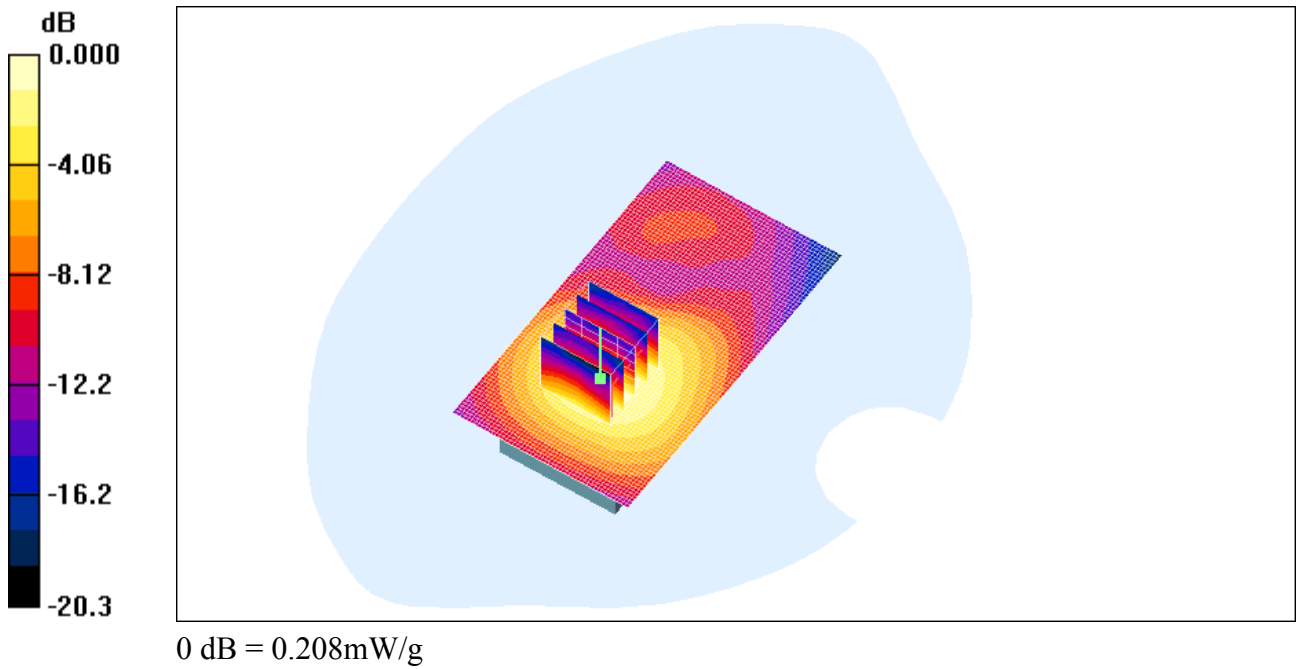

	Document		Page
	Appendix C for the BlackBerry® Smartphone Model RCX71UW SAR Report		50(58)
Author Data	Dates of Test	Test Report No	FCC ID:
Andrew Becker	February 02 – March 03, 2010	RTS-2474-1002-41	L6ARCX70UW

Date/Time: 2/26/2010 12:57:49 AM

Test Laboratory: RIM TESTING SERVICES

File Name:

[Vertical_Holster_Back_802.11b_high_chan_amb_temp_23.8C_liq_temp_21.7C.da4](#)

DUT: BlackBerry Smartphone; Type: Sample ; Serial: 21D06A83

Program Name: Compliance Testing: (Body worn)

Communication System: 802.11 b (2450); Frequency: 2462 MHz; Duty Cycle: 1:1
Medium parameters used (interpolated): $f = 2462 \text{ MHz}$; $\sigma = 1.97 \text{ mho/m}$; $\epsilon_r = 50$; $\rho = 1000 \text{ kg/m}^3$

Phantom section: Flat Section

DASY4 Configuration:

- Probe: ET3DV6 - SN1644; ConvF(4.11, 4.11, 4.11); Calibrated: 11/11/2009
- Sensor-Surface: 4mm (Mechanical Surface Detection)
- Electronics: DAE3 Sn473; Calibrated: 1/4/2010
- Phantom: SAM 2; Type: SAM 4.0; Serial: 1080
- Measurement SW: DASY4, V4.7 Build 80; Postprocessing SW: SEMCAD, V1.8 Build 186

Body/Area Scan (51x91x1): Measurement grid: $dx=15\text{mm}$, $dy=15\text{mm}$

[Info: Interpolated medium parameters used for SAR evaluation.](#)

Maximum value of SAR (interpolated) = 0.152 mW/g

Body/Zoom Scan (5x5x7) (5x5x7)/Cube 0: Measurement grid: $dx=7.5\text{mm}$, $dy=7.5\text{mm}$, $dz=5\text{mm}$

Reference Value = 6.19 V/m; Power Drift = -0.080 dB

Peak SAR (extrapolated) = 0.342 W/kg

SAR(1 g) = 0.152 mW/g; SAR(10 g) = 0.079 mW/g

[Info: Interpolated medium parameters used for SAR evaluation.](#)

Maximum value of SAR (measured) = 0.156 mW/g

	Document Appendix C for the BlackBerry® Smartphone Model RCX71UW SAR Report		Page 51(58)
	Author Data Andrew Becker	Dates of Test February 02 – March 03, 2010	Test Report No RTS-2474-1002-41

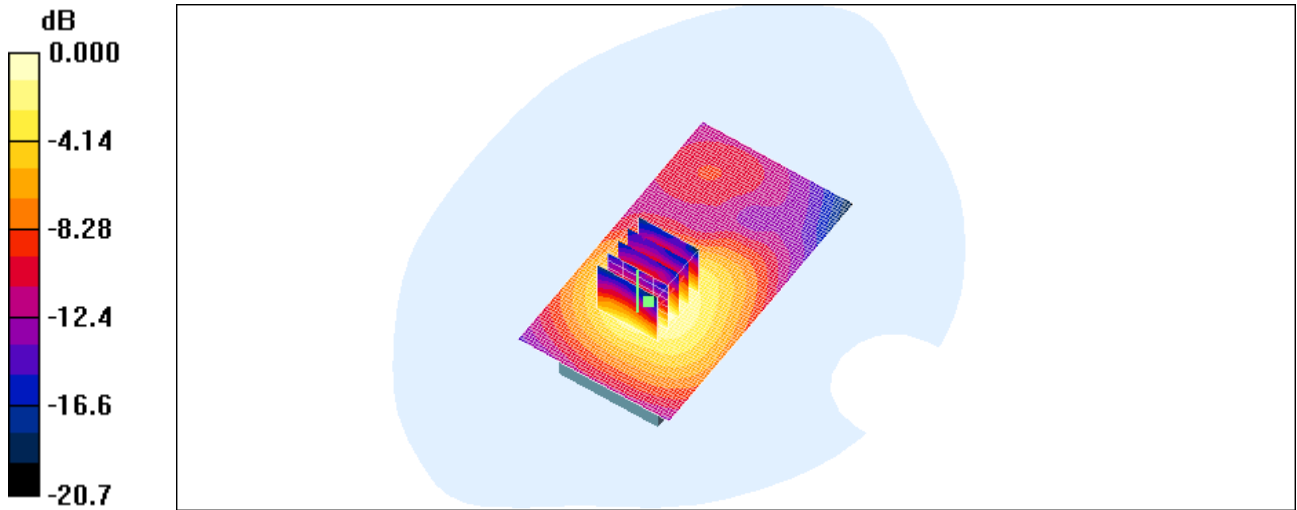

0 dB = 0.156mW/g

	Document		Page
	Appendix C for the BlackBerry® Smartphone Model RCX71UW SAR Report		52(58)
Author Data	Dates of Test	Test Report No	FCC ID:
Andrew Becker	February 02 – March 03, 2010	RTS-2474-1002-41	L6ARCX70UW

Date/Time: 2/26/2010 1:21:46 AM

Test Laboratory: RIM TESTING SERVICES

File Name:

[Vertical_Holster_Front_802.11b_low_chan_amb_temp_23.5C_liq_temp_21.6C.da4](#)

DUT: BlackBerry Smartphone; Type: Sample ; Serial: 21D06A83

Program Name: Compliance Testing: (Body worn)

Communication System: 802.11 b (2450); Frequency: 2412 MHz; Duty Cycle: 1:1
Medium parameters used (interpolated): $f = 2412$ MHz; $\sigma = 1.95$ mho/m; $\epsilon_r = 50.5$; $\rho = 1000$ kg/m³

Phantom section: Flat Section

DASY4 Configuration:

- Probe: ET3DV6 - SN1644; ConvF(4.11, 4.11, 4.11); Calibrated: 11/11/2009
- Sensor-Surface: 4mm (Mechanical Surface Detection)
- Electronics: DAE3 Sn473; Calibrated: 1/4/2010
- Phantom: SAM 2; Type: SAM 4.0; Serial: 1080
- Measurement SW: DASY4, V4.7 Build 80; Postprocessing SW: SEMCAD, V1.8 Build 186

Body/Area Scan (51x91x1): Measurement grid: dx=15mm, dy=15mm

[Info: Interpolated medium parameters used for SAR evaluation.](#)

Maximum value of SAR (interpolated) = 0.082 mW/g

Body/Zoom Scan (5x5x7) (5x5x7)/Cube 0: Measurement grid: dx=7.5mm, dy=7.5mm, dz=5mm

Reference Value = 4.37 V/m; Power Drift = -0.125 dB

Peak SAR (extrapolated) = 0.172 W/kg

SAR(1 g) = 0.078 mW/g; SAR(10 g) = 0.041 mW/g

[Info: Interpolated medium parameters used for SAR evaluation.](#)

Maximum value of SAR (measured) = 0.083 mW/g

	Document Appendix C for the BlackBerry® Smartphone Model RCX71UW SAR Report		Page 53(58)
	Author Data Andrew Becker	Dates of Test February 02 – March 03, 2010	Test Report No RTS-2474-1002-41

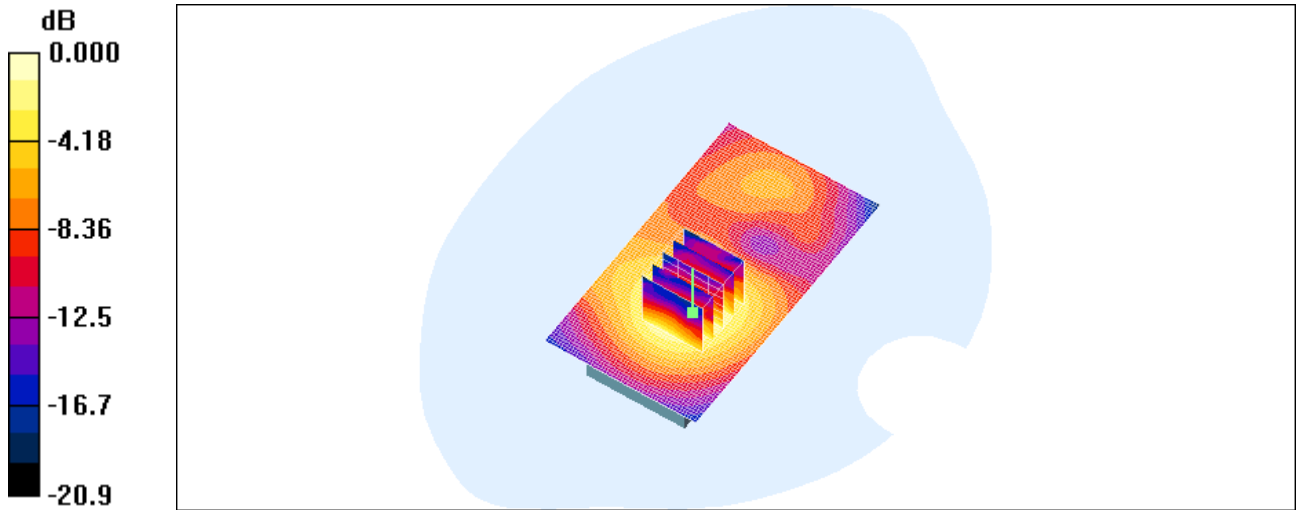

0 dB = 0.083mW/g

	Document		Page
	Appendix C for the BlackBerry® Smartphone Model RCX71UW SAR Report		54(58)
Author Data	Dates of Test	Test Report No	FCC ID:
Andrew Becker	February 02 – March 03, 2010	RTS-2474-1002-41	L6ARCX70UW

Date/Time: 2/26/2010 1:44:01 AM

Test Laboratory: RIM TESTING SERVICES

File Name:

[Vertical_Holster_HS#1_Back_802.11b_low_chan_amb_temp_23.3C_liq_temp_21.4C.da](#)
[4](#)

DUT: BlackBerry Smartphone; Type: Sample ; Serial: 21D06A83

Program Name: Compliance Testing: (Body worn)

Communication System: 802.11 b (2450); Frequency: 2412 MHz; Duty Cycle: 1:1
Medium parameters used (interpolated): $f = 2412$ MHz; $\sigma = 1.95$ mho/m; $\epsilon_r = 50.5$; $\rho = 1000$ kg/m³

Phantom section: Flat Section

DASY4 Configuration:

- Probe: ET3DV6 - SN1644; ConvF(4.11, 4.11, 4.11); Calibrated: 11/11/2009
- Sensor-Surface: 4mm (Mechanical Surface Detection)
- Electronics: DAE3 Sn473; Calibrated: 1/4/2010
- Phantom: SAM 2; Type: SAM 4.0; Serial: 1080
- Measurement SW: DASY4, V4.7 Build 80; Postprocessing SW: SEMCAD, V1.8 Build 186

Body/Area Scan (51x91x1): Measurement grid: dx=15mm, dy=15mm

[Info: Interpolated medium parameters used for SAR evaluation.](#)

Maximum value of SAR (interpolated) = 0.267 mW/g

Body/Zoom Scan (5x5x7) (5x5x7)/Cube 0: Measurement grid: dx=7.5mm, dy=7.5mm, dz=5mm

Reference Value = 7.90 V/m; Power Drift = -0.044 dB

Peak SAR (extrapolated) = 0.587 W/kg

SAR(1 g) = 0.262 mW/g; SAR(10 g) = 0.139 mW/g

[Info: Interpolated medium parameters used for SAR evaluation.](#)

Maximum value of SAR (measured) = 0.266 mW/g

	Document Appendix C for the BlackBerry® Smartphone Model RCX71UW SAR Report		Page 55(58)
	Author Data Andrew Becker	Dates of Test February 02 – March 03, 2010	Test Report No RTS-2474-1002-41

0 dB = 0.266mW/g

	Document		Page
	Appendix C for the BlackBerry® Smartphone Model RCX71UW SAR Report		56(58)
Author Data	Dates of Test	Test Report No	FCC ID:
Andrew Becker	February 02 – March 03, 2010	RTS-2474-1002-41	L6ARCX70UW

Date/Time: 2/26/2010 2:03:52 AM

Test Laboratory: RIM TESTING SERVICES

File Name:

[25mm Spacer Back 802.11b low chan amb temp 24.0C liq temp 21.7C.da4](#)

DUT: BlackBerry Smartphone; Type: Sample ; Serial: 21D06A83

Program Name: Compliance Testing: (Body worn)

Communication System: 802.11 b (2450); Frequency: 2412 MHz; Duty Cycle: 1:1
Medium parameters used (interpolated): $f = 2412$ MHz; $\sigma = 1.95$ mho/m; $\epsilon_r = 50.5$; $\rho = 1000$ kg/m³

Phantom section: Flat Section

DASY4 Configuration:

- Probe: ET3DV6 - SN1644; ConvF(4.11, 4.11, 4.11); Calibrated: 11/11/2009
- Sensor-Surface: 4mm (Mechanical Surface Detection)
- Electronics: DAE3 Sn473; Calibrated: 1/4/2010
- Phantom: SAM 2; Type: SAM 4.0; Serial: 1080
- Measurement SW: DASY4, V4.7 Build 80; Postprocessing SW: SEMCAD, V1.8 Build 186

Body/Area Scan (51x91x1): Measurement grid: dx=15mm, dy=15mm

[Info: Interpolated medium parameters used for SAR evaluation.](#)

Maximum value of SAR (interpolated) = 0.145 mW/g

Body/Zoom Scan (5x5x7) (5x5x7)/Cube 0: Measurement grid: dx=7.5mm, dy=7.5mm, dz=5mm

Reference Value = 7.18 V/m; Power Drift = -0.060 dB

Peak SAR (extrapolated) = 0.294 W/kg

SAR(1 g) = 0.139 mW/g; SAR(10 g) = 0.081 mW/g

[Info: Interpolated medium parameters used for SAR evaluation.](#)

Maximum value of SAR (measured) = 0.143 mW/g

	Document Appendix C for the BlackBerry® Smartphone Model RCX71UW SAR Report		Page 57(58)
	Author Data Andrew Becker	Dates of Test February 02 – March 03, 2010	Test Report No RTS-2474-1002-41

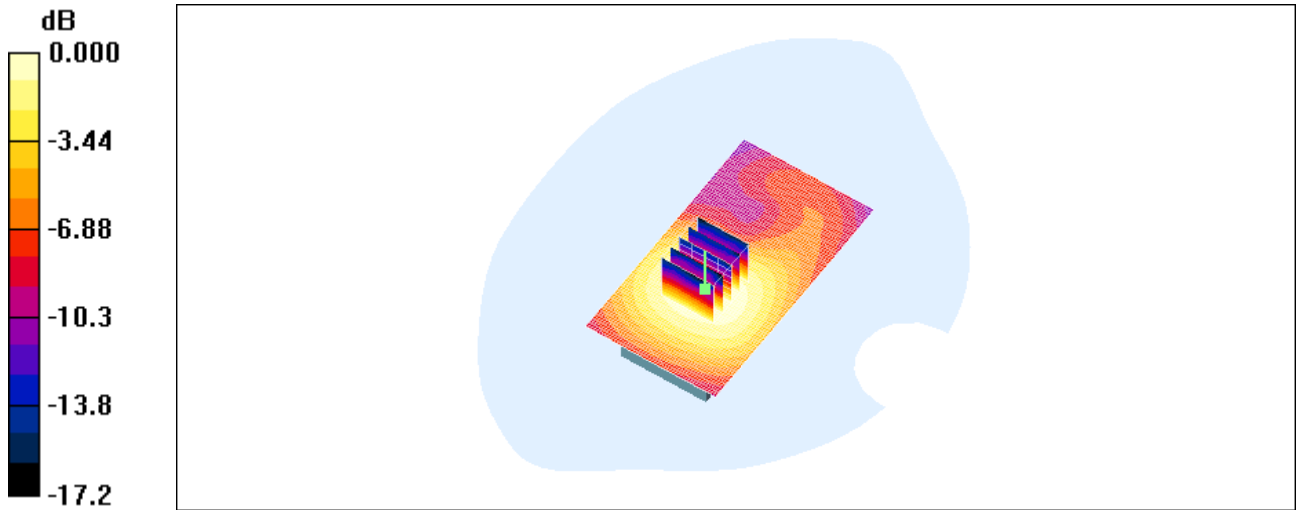

0 dB = 0.143mW/g

	Document Appendix C for the BlackBerry® Smartphone Model RCX71UW SAR Report		Page 58(58)
	Author Data Andrew Becker	Dates of Test February 02 – March 03, 2010	Test Report No RTS-2474-1002-41

Z axis plot for the worst case body configuration:

