

ENGINEERING TEST REPORT

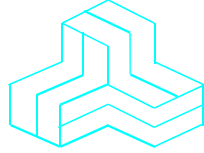

BlackBerry Presenter
Model No.: RCR11BW (Marketing M/N: BP-100)

FCC ID: L6ARCR10BW
IC: 2503A-RCR10BW

Applicant:
Research In Motion Limited
295 Phillip St.
Waterloo, ON
Canada, N2L 3W8

Tested in Accordance With

Federal Communications Commission (FCC)
47 CFR, Part 15, Subpart B
Class B Unintentional Radiators

UltraTech's File No.: RIM-029F15B

This Test report is Issued under the Authority of
Tri M. Luu, Professional Engineer,
Vice President of Engineering
UltraTech Group of Labs

Date: October 7, 2009



Report Prepared by: JaeWook Choi

Issued Date: October 7, 2009

Tested by: Hung Trinh, RF/EMI Technician

Test Dates: September 14, 2009 / October 5 & 7, 2009

- *The results in this Test Report apply only to the sample(s) tested, and the sample tested is randomly selected.*
- *This report must not be used by the client to claim product endorsement by NVLAP or any agency of the US Government*

UltraTech

3000 Bristol Circle, Oakville, Ontario, Canada, L6H 6G4

Tel.: (905) 829-1570 Fax.: (905) 829-8050

Website: www.ultratech-labs.com, Email: vic@ultratech-labs.com, Email: tri@ultratech-labs.com



91038



1309



46390-2049



200093-0



SL2-IN-E-1119R



Korea KCC-RRL

CA2049

TABLE OF CONTENTS

| | |
|--|-----------|
| EXHIBIT 1. INTRODUCTION | 1 |
| 1.1. SCOPE..... | 1 |
| 1.2. RELATED SUBMITTAL(S)/GRANT(S) | 1 |
| 1.3. NORMATIVE REFERENCES..... | 1 |
| EXHIBIT 2. PERFORMANCE ASSESSMENT..... | 2 |
| 2.1. CLIENT INFORMATION | 2 |
| 2.2. EQUIPMENT UNDER TEST (EUT) INFORMATION..... | 2 |
| 2.3. EUT'S TECHNICAL SPECIFICATIONS | 3 |
| 2.4. LIST OF EUT'S PORTS..... | 3 |
| 2.5. ANCILLARY EQUIPMENT | 4 |
| 2.6. GENERAL BLOCK DIAGRAM | 4 |
| EXHIBIT 3. EUT OPERATING CONDITIONS AND CONFIGURATIONS DURING TESTS..... | 5 |
| 3.1. OPERATIONAL TEST CONDITIONS & ARRANGEMENT FOR TEST SIGNALS..... | 5 |
| EXHIBIT 4. SUMMARY OF TEST RESULTS | 6 |
| 4.1. LOCATION OF TESTS | 6 |
| 4.2. APPLICABILITY & SUMMARY OF EMC EMISSION TEST RESULTS | 6 |
| 4.3. MODIFICATIONS REQUIRED FOR COMPLIANCE..... | 6 |
| EXHIBIT 5. MEASUREMENTS, EXAMINATIONS & TEST DATA FOR EMC EMISSIONS | 7 |
| 5.1. TEST PROCEDURES | 7 |
| 5.2. MEASUREMENT UNCERTAINTIES | 7 |
| 5.3. MEASUREMENT EQUIPMENT USED | 7 |
| 5.4. ESSENTIAL/PRIMARY FUNCTIONS AS DECLARED BY THE MANUFACTURER..... | 7 |
| 5.5. POWER LINE CONDUCTED EMISSIONS [§ 15.107(A)] | 8 |
| 5.6. RECEIVER SPURIOUS/HARMONIC RADIATED EMISSIONS [§ 15.109(A)] | 13 |
| 5.7. RADIATED EMISSIONS FROM CLASS B UNINTENTIONAL RADIATORS (DIGITAL DEVICES) [§ 15.109(A)] | 15 |
| EXHIBIT 6. TEST EQUIPMENTS LIST | 17 |
| EXHIBIT 7. MEASUREMENT UNCERTAINTY | 18 |
| 7.1. LINE CONDUCTED EMISSION MEASUREMENT UNCERTAINTY | 18 |
| 7.2. RADIATED EMISSION MEASUREMENT UNCERTAINTY | 19 |
| EXHIBIT 8. MEASUREMENT METHODS | 20 |
| 8.1. GENERAL TEST CONDITIONS | 20 |
| EXHIBIT 9. LABELLING & VERIFICATION REQUIREMENTS..... | 28 |
| 9.1. SECTION 15.19 – LABELLING REQUIREMENTS | 28 |
| 9.2. SECTIONS 15.21 & 15.105 – INFORMATION TO USER | 28 |
| 9.3. SECTION 2.902 - VERIFICATION | 28 |
| 9.4. SECTION 2.909 – RESPONSIBLE PARTY | 29 |
| 9.5. SECTION 2.945 – SAMPLING TEST OF EQUIPMENT COMPLIANCE | 29 |
| 9.6. SECTION 2.946 – PENALTY FOR FAILURE TO PROVIDE TEST SAMPLES AND DATA..... | 30 |
| 9.7. SECTION 2.952 - LIMITATION ON VERIFICATION | 30 |
| 9.8. SECTION 2.953 - RESPONSIBILITY FOR COMPLIANCE..... | 30 |

9.9. SECTION 2.954 - IDENTIFICATION 31
9.10. SECTION 2.955 - RETENTION OF RECORDS..... 31
9.11. SECTION 2.956 - FCC INSPECTION & SUBMISSION OF EQUIPMENT FOR TESTING 32

ULTRATECH GROUP OF LABS

3000 Bristol Circle, Oakville, Ontario, Canada L6H 6G4
Tel. #: 905-829-1570, Fax. #: 905-829-8050, Email: vic@ultratech-labs.com, Website: <http://www.ultratech-labs.com>

File #: RIM-029F15B
October 7, 2009

All test results contained in this engineering test report are traceable to National Institute of Standards and Technology (NIST)

EXHIBIT 1. INTRODUCTION

1.1. SCOPE

| | |
|-------------------------|--|
| Reference: | FCC Part 15, Subpart B, Sections 15.107, 15.109 & 15.111 |
| Title: | Telecommunication - 47 Code of Federal Regulations (CFR), Part 15 |
| Purpose of Test: | Equipment Certification for Frequency Hopping System Transmitter Operating in the Frequency Band 2402-2480 MHz |
| Test Procedures: | Both conducted and radiated emissions measurements were conducted in accordance with American National Standards Institute ANSI C63.4 - American National Standard for Methods of Measurement of Radio-Noise Emissions from Low-Voltage Electrical and Electronic Equipment in the Range of 9 kHz to 40 GHz. |

1.2. RELATED SUBMITTAL(S)/GRANT(S)

None.

1.3. NORMATIVE REFERENCES

| Publication | Year | Title |
|----------------------------|------|---|
| FCC CFR Parts 0-19, 80-End | 2008 | Code of Federal Regulations – Telecommunication |
| ANSI C63.4 | 2003 | American National Standard for Methods of Measurement of Radio-Noise Emissions from Low-Voltage Electrical and Electronic Equipment in the Range of 9 kHz to 40 GHz |

EXHIBIT 2. PERFORMANCE ASSESSMENT

2.1. CLIENT INFORMATION

| APPLICANT | |
|------------------------|--|
| Name: | Research In Motion Limited |
| Address: | 295 Phillip St. Waterloo, ON Canada, N2L 3W8 |
| Contact Person: | Mr. Masud Attayi Phone #: 1.519.888.7465 Email Address: mattayi@rim.com |

| MANUFACTURER | |
|------------------------|--|
| Name: | Research In Motion Limited |
| Address: | 295 Phillip St. Waterloo, ON Canada, N2L 3W8 |
| Contact Person: | Mr. Don Thompson Phone #: 1.519.888.7465 x 75407 Email Address: dthompson@rim.com |

2.2. EQUIPMENT UNDER TEST (EUT) INFORMATION

The following information (with the exception of the Date of Receipt) has been supplied by the applicant.

| | |
|---------------------------------------|---|
| Brand Name | Research In Motion Limited |
| Product Name: | BlackBerry Presenter |
| Model Name or Number: | RCR11BW (Marketing M/N: BP-100) |
| Serial Number: | Test Sample |
| Type of Equipment: | BlackBerry Presenter |
| Input Power Supply Type: | 5 VDC AC Power adapter |
| Primary User Functions of EUT: | Connect to the BlackBerry via Bluetooth and present presentations using monitor or projector using the VGA or S-Video output. |

ULTRATECH GROUP OF LABS

3000 Bristol Circle, Oakville, Ontario, Canada L6H 6G4
 Tel. #: 905-829-1570, Fax. #: 905-829-8050, Email: vic@ultratech-labs.com, Website: <http://www.ultratech-labs.com>

File #: RIM-029F15B
 October 7, 2009

All test results contained in this engineering test report are traceable to National Institute of Standards and Technology (NIST)

2.3. EUT'S TECHNICAL SPECIFICATIONS

| BLUETOOTH TRANSMITTER | |
|--|---|
| Equipment Type: | Base station |
| Intended Operating Environment: | Residential environment |
| Power Supply Requirement: | 5 VDC |
| RF Output Power Rating: | 10 dBm (10 mW) |
| Operating Frequency Range: | 2402-2480 MHz |
| Duty Cycle: | 9.375 % (worst case) |
| 20 dB Bandwidth: | 929.9 KHz for GFSK modulation 1.3908 MHz for $\pi/4$ DPQSK modulation 1.3868 MHz for 8DPSK modulation |
| Modulation Type: | G1D |
| Antenna Connector Type: | Integral antenna housed inside the enclosure. |
| Antenna Description: | Manufacturer: RIM Type: Printed PCB Model: N/A Gain: 0 dBi Frequency Range: 2400 ~ 2583.5 MHz |

| BLUETOOTH RECEIVER | |
|-----------------------------------|---------------|
| Operating Frequency Range: | 2402-2480 MHz |
| Oscillator Frequency(ies): | 26 MHz |

2.4. LIST OF EUT'S PORTS

| Port Number | EUT's Port Description | Number of Identical Ports | Connector Type |
|-------------|------------------------|---------------------------|----------------|
| 1 | USB (DC Power) | 1 | Micro USB |
| 2 | VESA (VGA) | 1 | VGA |
| 3 | S-VIDEO | 1 | S-VIDEO |

ULTRATECH GROUP OF LABS

3000 Bristol Circle, Oakville, Ontario, Canada L6H 6G4
 Tel. #: 905-829-1570, Fax. #: 905-829-8050, Email: vic@ultratech-labs.com, Website: <http://www.ultratech-labs.com>

File #: RIM-029F15B
 October 7, 2009

All test results contained in this engineering test report are traceable to National Institute of Standards and Technology (NIST)

2.5. ANCILLARY EQUIPMENT

The EUT was tested while connected to the following representative configuration of ancillary equipment necessary to exercise the ports during tests:

| Ancillary Equipment # 1 | |
|--------------------------|--|
| Description: | AC Power Adapter |
| Brand Name: | Research In Motion |
| Model Name or Number: | PSM04A0-050RIM (NY) or PSM04A0-050CHW1 (M) |
| Serial Number: | N/A |
| Cable Length & Type: | < 3 m, Non-shielded |
| Connected to EUT's Port: | USB |

2.6. General Block Diagram

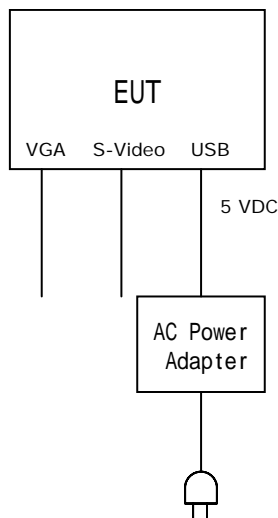

EXHIBIT 3. EUT OPERATING CONDITIONS AND CONFIGURATIONS DURING TESTS

3.1. OPERATIONAL TEST CONDITIONS & ARRANGEMENT FOR TEST SIGNALS

| | |
|-------------------------------|---|
| Operating Modes: | The EUT was set to the RF receiving mode |
| Special Test Software: | None |
| Special Hardware Used: | N/A |
| Receiver Test Antenna: | The EUT is tested with the antenna fitted in a manner typical of normal intended use as integral antenna equipment. |

| Receiver Signals | |
|--|---------------------------------|
| Frequency Band(s): | 2402-2480 MHz |
| Test Frequency(ies): (Near lowest & near highest frequencies in the frequency range of operation.) | 2402 MHz, 2441 MHz and 2480 MHz |

EXHIBIT 4. SUMMARY OF TEST RESULTS

4.1. LOCATION OF TESTS

All of the measurements described in this report were performed at Ultratech Group of Labs located in the city of Oakville, Province of Ontario, Canada.

Power Line Conducted Emissions were performed in UltraTech's shielded room, 16'(L) by 12'(W) by 12'(H).

Radiated Emissions were performed at the Ultratech's 3-10 TDK Semi-Anechoic Chamber situated in the Town of Oakville, province of Ontario. This test site been calibrated in accordance with ANSI C63.4, and found to be in compliance with the requirements of Sec. 2.948 of the FCC Rules. The descriptions and site measurement data of the Oakville 3-10 TDK Semi-Anechoic Chamber has been filed with FCC office (FCC File No.: 91038) and Industry Canada office (Industry Canada File No.: 2049A-3). Expiry Date: 2011-05-01.

4.2. APPLICABILITY & SUMMARY OF EMC EMISSION TEST RESULTS

| FCC Part 15, Subpart B | Test Requirements | Compliance (Yes/No) |
|------------------------|--|------------------------|
| 15.107(a), Class B | Power Line Conducted Emissions Measurements | Yes |
| 15.111(a) | Receiver Antenna Power Conducted Emissions for Non-Integral Antenna Port | N/A (Integral antenna) |
| 15.109(a) | Radiated Emissions from Radio Receivers | Yes |
| 15.109(a), Class B | Radiated Emissions from Unintentional Radiators (Digital Devices) | Yes |

4.3. MODIFICATIONS REQUIRED FOR COMPLIANCE

None.

EXHIBIT 5. MEASUREMENTS, EXAMINATIONS & TEST DATA FOR EMC EMISSIONS

5.1. TEST PROCEDURES

This section contains test results only. Details of test methods and procedures can be found in EXHIBIT 8. of this report.

5.2. MEASUREMENT UNCERTAINTIES

The measurement uncertainties stated were calculated in accordance with requirements of UKAS Document NIS 81 with a confidence level of 95%. Please refer to EXHIBIT 7. for Measurement Uncertainties.

5.3. MEASUREMENT EQUIPMENT USED

The measurement equipment used complied with the requirements of the Standards referenced in the Methods & Procedures ANSI C63.4.

5.4. ESSENTIAL/PRIMARY FUNCTIONS AS DECLARED BY THE MANUFACTURER

The BlackBerry Presenter is a Bluetooth enabled device that is used to display presentations from BlackBerry device on an external display, such as video projector or television screen.

5.5. POWER LINE CONDUCTED EMISSIONS [§ 15.107(a)]

5.5.1. Limits

The equipment shall meet the limits of the following table:

| Frequency of Emissions (MHz) | Class B Conducted Limit (dBµV) | |
|------------------------------|--------------------------------|-----------|
| | Quasi-Peak | Average |
| 0.15 to 0.5 | 66 to 56* | 56 to 46* |
| 0.5 to 5 | 56 | 46 |
| 5 to 30 | 60 | 50 |

* Decreasing linearly with logarithm of frequency

5.5.2. Method of Measurements

Refer to Ultratech Test Procedures ULTR-P001-200 & ANSI C63.4 for method of measurements.

5.5.3. Test Arrangement

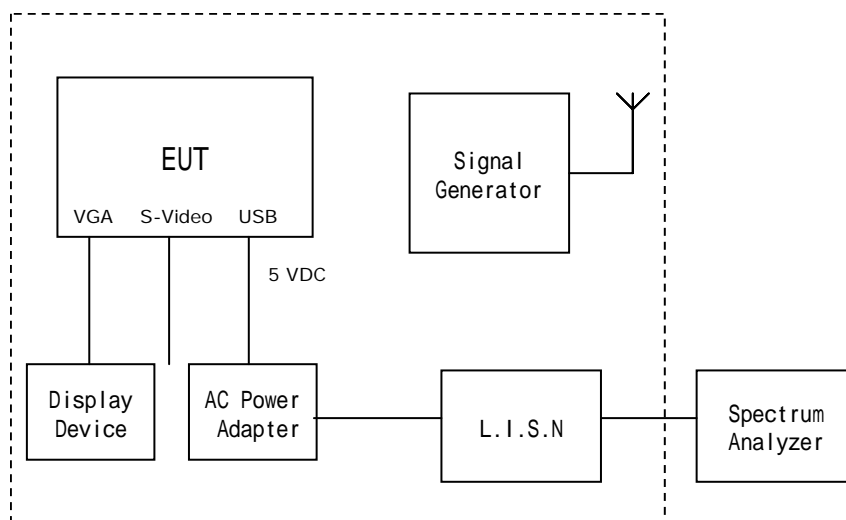

5.5.4. Test Data

5.5.4.1. 120 VAC, Line Tested: Hot
 AC Power Adapter M/N: PSM04A0-050RIM (NY)

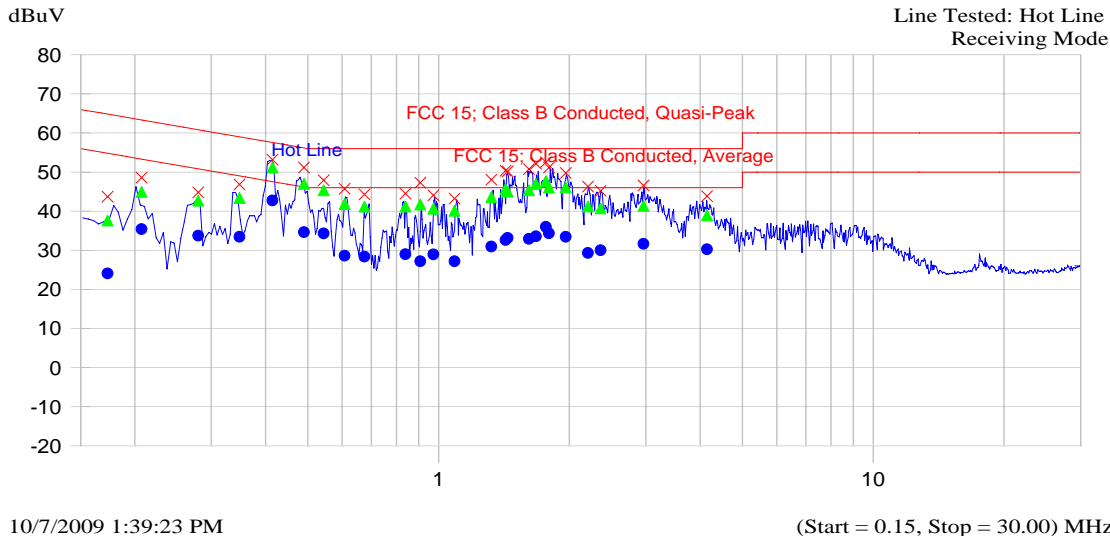

Current List

| Frequency MHz | Peak dBuV | QP dBuV | Delta dB | QP-QP Limit | Avg dBuV | Delta dB | Avg-Avg Limit | Trace Name |
|---------------|-----------|---------|----------|-------------|----------|----------|---------------|------------|
| 0.173 | 43.7 | 37.6 | -27.7 | | 24.1 | -31.2 | | Hot Line |
| 0.207 | 48.6 | 45.0 | -19.4 | | 35.4 | -18.9 | | Hot Line |
| 0.280 | 44.8 | 42.7 | -19.5 | | 33.7 | -18.5 | | Hot Line |
| 0.348 | 46.8 | 43.4 | -16.9 | | 33.5 | -16.8 | | Hot Line |
| 0.415 | 53.2 | 51.1 | -7.2 | | 42.7 | -5.6 | | Hot Line |
| 0.490 | 51.2 | 47.0 | -9.3 | | 34.6 | -11.6 | | Hot Line |
| 0.544 | 47.9 | 45.4 | -10.6 | | 34.3 | -11.7 | | Hot Line |
| 0.608 | 45.7 | 41.8 | -14.2 | | 28.6 | -17.4 | | Hot Line |
| 0.676 | 44.3 | 41.2 | -14.8 | | 28.4 | -17.6 | | Hot Line |
| 0.839 | 44.5 | 41.2 | -14.8 | | 29.0 | -17.0 | | Hot Line |
| 0.908 | 47.3 | 41.7 | -14.3 | | 27.2 | -18.8 | | Hot Line |
| 0.974 | 44.1 | 40.6 | -15.4 | | 28.9 | -17.1 | | Hot Line |
| 1.089 | 43.2 | 40.1 | -15.9 | | 27.2 | -18.8 | | Hot Line |
| 1.322 | 48.0 | 43.6 | -12.4 | | 30.9 | -15.1 | | Hot Line |
| 1.427 | 50.3 | 45.7 | -10.3 | | 32.6 | -13.4 | | Hot Line |
| 1.442 | 50.2 | 45.0 | -11.0 | | 33.2 | -12.8 | | Hot Line |
| 1.615 | 50.7 | 45.4 | -10.6 | | 32.9 | -13.1 | | Hot Line |
| 1.676 | 52.1 | 47.0 | -9.0 | | 33.6 | -12.4 | | Hot Line |
| 1.767 | 52.5 | 47.7 | -8.3 | | 36.0 | -10.0 | | Hot Line |
| 1.794 | 51.2 | 46.0 | -10.0 | | 34.3 | -11.7 | | Hot Line |
| 1.961 | 49.7 | 46.1 | -9.9 | | 33.4 | -12.6 | | Hot Line |
| 2.205 | 46.3 | 41.2 | -14.8 | | 29.3 | -16.7 | | Hot Line |
| 2.360 | 45.2 | 40.7 | -15.3 | | 30.0 | -16.0 | | Hot Line |
| 2.959 | 46.6 | 41.4 | -14.6 | | 31.6 | -14.4 | | Hot Line |
| 4.147 | 43.8 | 38.9 | -17.1 | | 30.3 | -15.7 | | Hot Line |

ULTRATECH GROUP OF LABS

3000 Bristol Circle, Oakville, Ontario, Canada L6H 6G4
 Tel. #: 905-829-1570, Fax. #: 905-829-8050, Email: vic@ultratech-labs.com, Website: <http://www.ultratech-labs.com>

File #: RIM-029F15B
 October 7, 2009

All test results contained in this engineering test report are traceable to National Institute of Standards and Technology (NIST)

5.5.4.2. 120 VAC, Line Tested: Neutral
 AC Power Adapter M/N: PSM04A0-050RIM (NY)

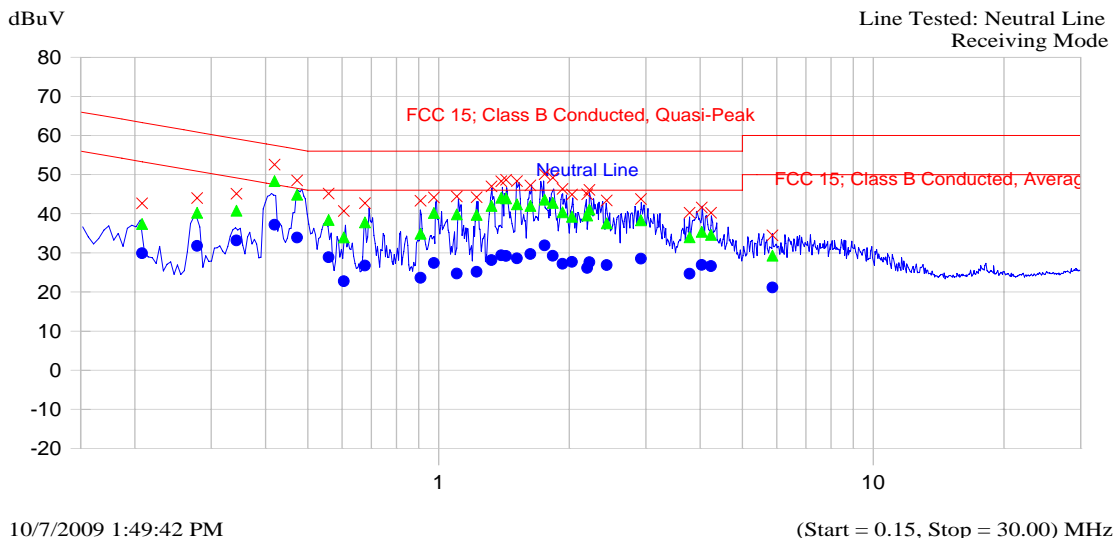

Current List

| Frequency MHz | Peak dBuV | QP dBuV | Delta QP-QP Limit dB | Avg dBuV | Delta Avg-Avg Limit dB | Trace Name |
|---------------|-----------|---------|----------------------|----------|------------------------|--------------|
| 0.208 | 42.7 | 37.4 | -26.9 | 29.9 | -24.4 | Neutral Line |
| 0.278 | 44.0 | 40.3 | -22.0 | 31.8 | -20.5 | Neutral Line |
| 0.343 | 45.1 | 40.8 | -19.7 | 33.2 | -17.2 | Neutral Line |
| 0.419 | 52.5 | 48.3 | -9.9 | 37.2 | -11.1 | Neutral Line |
| 0.473 | 48.5 | 44.9 | -11.9 | 33.9 | -12.8 | Neutral Line |
| 0.559 | 45.1 | 38.4 | -17.6 | 28.9 | -17.1 | Neutral Line |
| 0.605 | 40.7 | 34.0 | -22.0 | 22.7 | -23.3 | Neutral Line |
| 0.677 | 42.7 | 37.8 | -18.2 | 26.7 | -19.3 | Neutral Line |
| 0.909 | 43.3 | 34.9 | -21.1 | 23.6 | -22.4 | Neutral Line |
| 0.976 | 44.2 | 40.2 | -15.8 | 27.4 | -18.6 | Neutral Line |
| 1.102 | 44.4 | 39.8 | -16.2 | 24.7 | -21.3 | Neutral Line |
| 1.224 | 44.2 | 39.7 | -16.3 | 25.2 | -20.8 | Neutral Line |
| 1.324 | 47.0 | 42.0 | -14.0 | 28.1 | -17.9 | Neutral Line |
| 1.393 | 48.3 | 44.1 | -11.9 | 29.4 | -16.6 | Neutral Line |
| 1.429 | 48.7 | 43.9 | -12.1 | 29.2 | -16.8 | Neutral Line |
| 1.515 | 48.3 | 42.4 | -13.6 | 28.6 | -17.4 | Neutral Line |
| 1.626 | 47.2 | 42.0 | -14.0 | 29.7 | -16.3 | Neutral Line |
| 1.753 | 50.1 | 43.6 | -12.4 | 31.9 | -14.1 | Neutral Line |
| 1.832 | 49.2 | 42.8 | -13.2 | 29.2 | -16.8 | Neutral Line |
| 1.929 | 46.3 | 40.4 | -15.6 | 27.2 | -18.8 | Neutral Line |
| 2.028 | 44.9 | 39.2 | -16.8 | 27.7 | -18.3 | Neutral Line |
| 2.197 | 45.0 | 39.6 | -16.4 | 26.1 | -19.9 | Neutral Line |
| 2.225 | 46.1 | 41.1 | -14.9 | 27.6 | -18.4 | Neutral Line |
| 2.436 | 43.4 | 37.5 | -18.5 | 26.9 | -19.1 | Neutral Line |
| 2.922 | 43.7 | 38.3 | -17.7 | 28.5 | -17.5 | Neutral Line |
| 3.778 | 40.2 | 34.0 | -22.0 | 24.7 | -21.3 | Neutral Line |
| 4.032 | 41.6 | 35.4 | -20.6 | 26.9 | -19.1 | Neutral Line |
| 4.234 | 40.2 | 34.6 | -21.4 | 26.6 | -19.4 | Neutral Line |
| 5.863 | 34.5 | 29.3 | -30.7 | 21.1 | -28.9 | Neutral Line |

ULTRATECH GROUP OF LABS

3000 Bristol Circle, Oakville, Ontario, Canada L6H 6G4
 Tel. #: 905-829-1570, Fax. #: 905-829-8050, Email: vic@ultratech-labs.com, Website: <http://www.ultratech-labs.com>

File #: RIM-029F15B
 October 7, 2009

All test results contained in this engineering test report are traceable to National Institute of Standards and Technology (NIST)

5.5.4.3. 120 VAC, Line Tested: Hot
 AC Power Adapter M/N: PSM04R-050CHW1 (M)

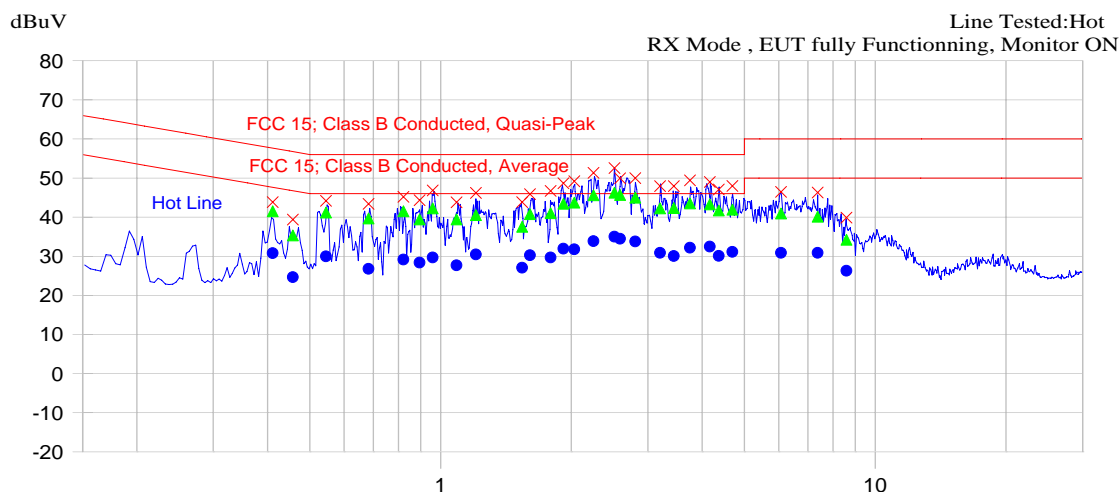

10/5/2009 1:03:33 PM

(Start = 0.15, Stop = 30.00) MHz

Current List

| Frequency MHz | Peak dBuV | QP dBuV | Delta dB | QP-QP Limit dB | Avg dBuV | Delta dB | Avg-Avg Limit dB | Trace Name |
|---------------|-----------|---------|----------|----------------|----------|----------|------------------|------------|
| 0.411 | 43.8 | 41.5 | -17.0 | | 30.8 | -17.7 | | Hot Line |
| 0.457 | 39.4 | 35.3 | -21.9 | | 24.7 | -22.5 | | Hot Line |
| 0.545 | 44.2 | 41.2 | -14.8 | | 30.0 | -16.0 | | Hot Line |
| 0.683 | 43.4 | 39.7 | -16.3 | | 26.8 | -19.2 | | Hot Line |
| 0.822 | 45.2 | 41.5 | -14.5 | | 29.2 | -16.8 | | Hot Line |
| 0.895 | 44.3 | 39.4 | -16.6 | | 28.4 | -17.6 | | Hot Line |
| 0.960 | 46.8 | 42.3 | -13.7 | | 29.7 | -16.3 | | Hot Line |
| 1.088 | 43.8 | 39.4 | -16.6 | | 27.7 | -18.3 | | Hot Line |
| 1.205 | 46.2 | 40.6 | -15.4 | | 30.5 | -15.5 | | Hot Line |
| 1.539 | 43.8 | 37.6 | -18.4 | | 27.1 | -18.9 | | Hot Line |
| 1.607 | 45.9 | 40.8 | -15.2 | | 30.3 | -15.7 | | Hot Line |
| 1.791 | 46.7 | 41.0 | -15.0 | | 29.7 | -16.3 | | Hot Line |
| 1.916 | 48.6 | 43.4 | -12.6 | | 31.9 | -14.1 | | Hot Line |
| 2.031 | 49.2 | 43.7 | -12.3 | | 31.8 | -14.2 | | Hot Line |
| 2.247 | 51.3 | 45.6 | -10.4 | | 33.9 | -12.1 | | Hot Line |
| 2.512 | 52.5 | 46.2 | -9.8 | | 35.0 | -11.0 | | Hot Line |
| 2.588 | 49.9 | 45.7 | -10.3 | | 34.4 | -11.6 | | Hot Line |
| 2.805 | 50.0 | 45.0 | -11.0 | | 33.8 | -12.2 | | Hot Line |
| 3.198 | 47.9 | 42.2 | -13.8 | | 30.9 | -15.1 | | Hot Line |
| 3.442 | 47.9 | 42.3 | -13.7 | | 30.0 | -16.0 | | Hot Line |
| 3.745 | 49.4 | 43.5 | -12.5 | | 32.2 | -13.8 | | Hot Line |
| 4.166 | 49.0 | 43.3 | -12.7 | | 32.5 | -13.5 | | Hot Line |
| 4.364 | 47.0 | 41.7 | -14.3 | | 30.1 | -15.9 | | Hot Line |
| 4.692 | 47.9 | 41.9 | -14.1 | | 31.1 | -14.9 | | Hot Line |
| 6.073 | 46.4 | 40.9 | -19.1 | | 30.9 | -19.1 | | Hot Line |
| 7.368 | 46.3 | 40.1 | -19.9 | | 30.9 | -19.1 | | Hot Line |
| 8.580 | 39.9 | 34.2 | -25.8 | | 26.3 | -23.7 | | Hot Line |

ULTRATECH GROUP OF LABS

3000 Bristol Circle, Oakville, Ontario, Canada L6H 6G4
 Tel. #: 905-829-1570, Fax. #: 905-829-8050, Email: vic@ultratech-labs.com, Website: <http://www.ultratech-labs.com>

File #: RIM-029F15B
 October 7, 2009

All test results contained in this engineering test report are traceable to National Institute of Standards and Technology (NIST)

**5.5.4.4. 120 VAC, Line Tested: Neutral
 AC Power Adapter M/N: PSM04R-050CHW1 (M)**

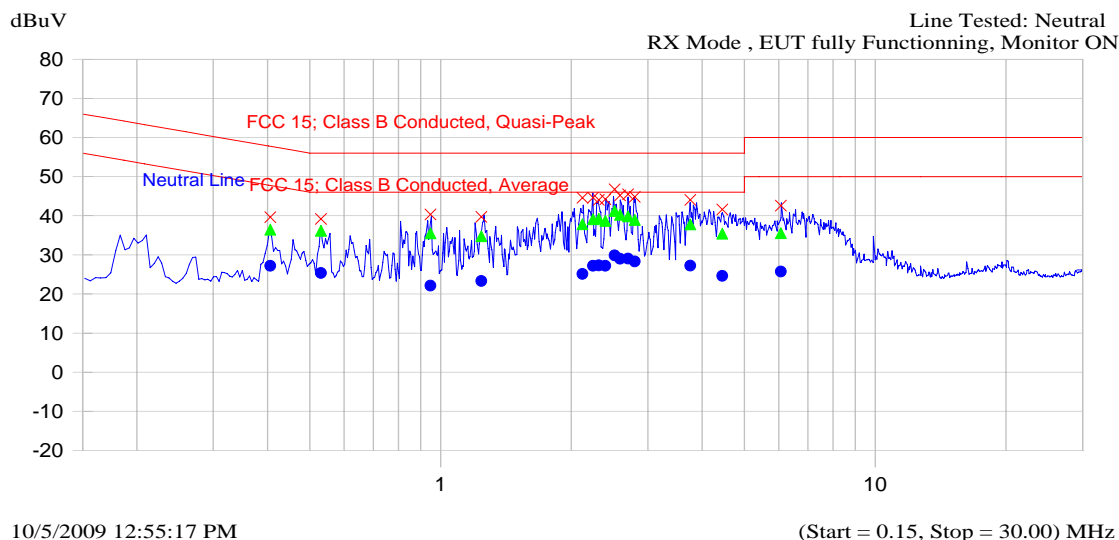

Current List

| Frequency MHz | Peak dBuV | QP dBuV | Delta dB | QP-QP Limit | Avg dBuV | Delta dB | Avg-Avg Limit | Trace Name |
|---------------|-----------|---------|----------|-------------|----------|----------|---------------|--------------|
| 0.406 | 39.6 | 36.4 | -22.2 | | 27.2 | -21.4 | | Neutral Line |
| 0.531 | 39.2 | 36.1 | -19.9 | | 25.3 | -20.7 | | Neutral Line |
| 0.948 | 40.3 | 35.5 | -20.5 | | 22.1 | -23.9 | | Neutral Line |
| 1.241 | 39.7 | 34.8 | -21.2 | | 23.3 | -22.7 | | Neutral Line |
| 2.121 | 44.6 | 37.8 | -18.2 | | 25.1 | -20.9 | | Neutral Line |
| 2.244 | 44.6 | 39.1 | -16.9 | | 27.2 | -18.8 | | Neutral Line |
| 2.311 | 44.0 | 39.2 | -16.8 | | 27.3 | -18.7 | | Neutral Line |
| 2.395 | 44.2 | 38.7 | -17.3 | | 27.2 | -18.8 | | Neutral Line |
| 2.515 | 46.7 | 41.2 | -14.8 | | 29.8 | -16.2 | | Neutral Line |
| 2.589 | 45.2 | 40.2 | -15.8 | | 29.0 | -17.0 | | Neutral Line |
| 2.699 | 45.5 | 39.8 | -16.2 | | 29.0 | -17.0 | | Neutral Line |
| 2.797 | 44.8 | 38.9 | -17.1 | | 28.3 | -17.7 | | Neutral Line |
| 3.758 | 44.1 | 37.8 | -18.2 | | 27.2 | -18.8 | | Neutral Line |
| 4.452 | 41.6 | 35.4 | -20.6 | | 24.6 | -21.4 | | Neutral Line |
| 6.064 | 42.6 | 35.6 | -24.4 | | 25.7 | -24.3 | | Neutral Line |

5.6. RECEIVER SPURIOUS/HARMONIC RADIATED EMISSIONS [§ 15.109(a)]

5.6.1. Limits

The equipment shall meet the limits of the following table:

| Test Frequency Range (MHz) | Limits @ 3 m (dBµV/m) | EMI Detector Used | Measuring Bandwidth (kHz) |
|----------------------------|-----------------------|---|---|
| 30 – 88 | 40.0 | Quasi-Peak | RBW = 120 kHz, VBW ≥ 120 kHz |
| 88 – 216 | 43.5 | Quasi-Peak | RBW = 120 kHz, VBW ≥ 120 kHz |
| 216 – 960 | 46.0 | Quasi-Peak | RBW = 120 kHz, VBW ≥ 120 kHz |
| Above 960 | 54.0 | Quasi-Peak (below 1 GHz) / Average (above 1 GHz) | RBW = 120 kHz, VBW ≥ 120 kHz / RBW = 1 MHz, VBW ≥ 1 Hz |

5.6.2. Method of Measurements

Refer to EXHIBIT 8. of this test report and ANSI C63.4 for radiated emissions test method. Input signal of 60 dBµV was fed at each receiver frequencies to stimulate the receiver.

5.6.3. Test Arrangement

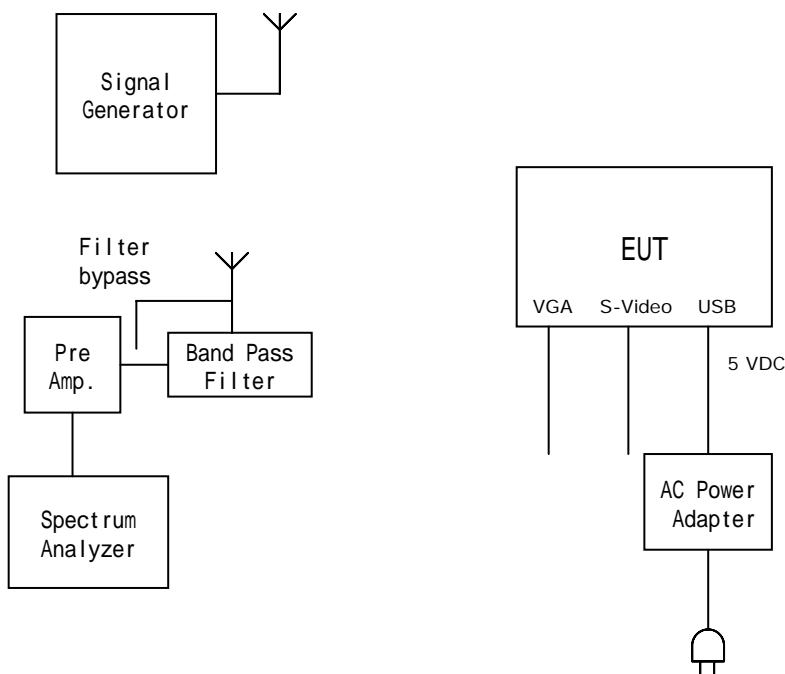

5.6.4. Test data

5.6.4.1. Receiver Mode

Remarks:

- The measuring receiver shall be tuned over the frequency range 30 MHz to 12.5 GHz.

| Frequency (MHz) | RF Level (dB μ V/m) | Detector Used (Peak/QP) | Antenna Plane (H/V) | Limit (dB μ V/m) | Margin (dB) | Pass/ Fail |
|---|-------------------------------|-------------------------------|---------------------------|-------------------------|----------------|---------------|
| No signal found within 20 dB below limit. | | | | | | |

5.7. RADIATED EMISSIONS FROM CLASS B UNINTENTIONAL RADIATORS (DIGITAL DEVICES) [§ 15.109(a)]

5.7.1. Limits

The equipment shall meet the limits of the following table:

| Test Frequency Range (MHz) | Limits @ 3 m (dBµV/m) | EMI Detector Used | Measuring Bandwidth (kHz) |
|----------------------------|-----------------------|--|--|
| 30 – 88 | 40.0 | Quasi-Peak | RBW = 120 kHz, VBW ≥ 120 kHz |
| 88 – 216 | 43.5 | Quasi-Peak | RBW = 120 kHz, VBW ≥ 120 kHz |
| 216 – 960 | 46.0 | Quasi-Peak | RBW = 120 kHz, VBW ≥ 120 kHz |
| Above 960 | 54.0 | Quasi-Peak (below 1 GHz) / Average (above 1 GHz) | RBW = 120 kHz, VBW ≥ 120 kHz / RBW = 1 MHz, VBW ≥ 1 Hz |

5.7.2. Method of Measurements

The EUT shall be scanned from 30 MHz to the 5th harmonic of the highest oscillator frequency in the digital devices or 1 GHz whichever is higher. Please refer to the EXHIBIT 8. of this test report and ANSI C63.4 for radiated emissions test method.

5.7.3. Test Arrangement

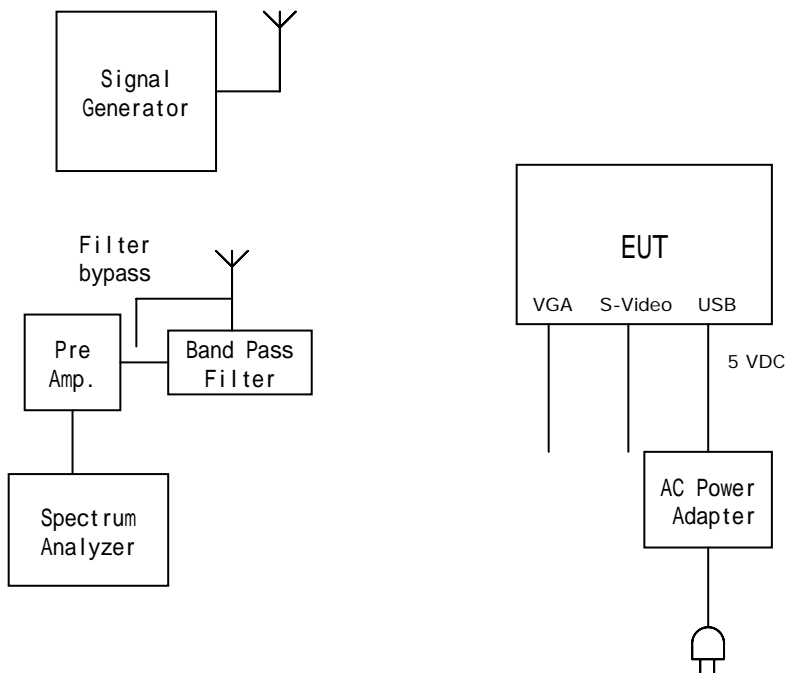

5.7.4. Test Data

Remarks:

- The measuring receiver shall be tuned over the frequency range 30 MHz to 12.5 GHz.

| Frequency (MHz) | RF Level (dBµV/m) | Detector Used (Peak/QP) | Antenna Plane (H/V) | Limit (dBµV/m) | Margin (dB) | Pass/Fail |
|-----------------|-------------------|-------------------------|---------------------|----------------|-------------|-----------|
| 30.78 | 36.07 | PEAK | V | 40.0 | -3.93 | PASS |
| 30.78 | 28.72 | PEAK | H | 40.0 | -11.28 | PASS |
| 38.19 | 32.47 | PEAK | V | 40.0 | -7.53 | PASS |
| 38.19 | 23.74 | PEAK | H | 40.0 | -16.26 | PASS |
| 131.41 | 30.07 | PEAK | V | 43.5 | -13.43 | PASS |
| 131.41 | 28.68 | PEAK | H | 43.5 | -14.82 | PASS |
| 154.97 | 30.50 | PEAK | V | 43.5 | -13.00 | PASS |
| 154.97 | 28.95 | PEAK | H | 43.5 | -14.55 | PASS |
| 234.29 | 35.82 | PEAK | V | 46.0 | -10.18 | PASS |
| 234.29 | 31.52 | PEAK | H | 46.0 | -14.48 | PASS |
| 307.85 | 31.33 | PEAK | V | 46.0 | -14.67 | PASS |
| 307.85 | 31.71 | PEAK | H | 46.0 | -14.29 | PASS |
| 424.68 | 33.50 | PEAK | V | 46.0 | -12.50 | PASS |
| 424.68 | 26.41 | PEAK | H | 46.0 | -19.59 | PASS |
| 459.77 | 34.73 | PEAK | V | 46.0 | -11.27 | PASS |
| 459.77 | 33.37 | PEAK | H | 46.0 | -12.63 | PASS |
| 486.86 | 31.53 | PEAK | V | 46.0 | -14.47 | PASS |
| 486.86 | 26.86 | PEAK | H | 46.0 | -19.14 | PASS |
| 525.32 | 34.32 | PEAK | V | 46.0 | -11.68 | PASS |
| 525.32 | 32.40 | PEAK | H | 46.0 | -13.60 | PASS |
| 591.18 | 32.82 | PEAK | V | 46.0 | -13.18 | PASS |
| 591.18 | 31.18 | PEAK | H | 46.0 | -14.82 | PASS |
| 656.41 | 34.08 | PEAK | V | 46.0 | -11.92 | PASS |
| 656.41 | 30.24 | PEAK | H | 46.0 | -15.76 | PASS |
| 722.43 | 36.94 | PEAK | V | 46.0 | -9.06 | PASS |
| 722.43 | 37.08 | PEAK | H | 46.0 | -8.92 | PASS |
| 919.87 | 38.17 | PEAK | V | 46.0 | -7.83 | PASS |
| 989.87 | 36.20 | PEAK | H | 54.0 | -17.80 | PASS |
| 1133.01 | 50.21 | PEAK | V | 54.0 | -3.79 | PASS |
| 1133.01 | 45.62 | PEAK | H | 54.0 | -8.38 | PASS |
| 1487.23 | 30.71 | AVG | V | 54.0 | -23.29 | PASS |
| 1487.23 | 47.49 | PEAK | H | 54.0 | -6.51 | PASS |

ULTRATECH GROUP OF LABS

3000 Bristol Circle, Oakville, Ontario, Canada L6H 6G4
 Tel. #: 905-829-1570, Fax. #: 905-829-8050, Email: vic@ultratech-labs.com, Website: <http://www.ultratech-labs.com>

File #: RIM-029F15B
 October 7, 2009

All test results contained in this engineering test report are traceable to National Institute of Standards and Technology (NIST)

EXHIBIT 6. Test Equipments List

| Test Instruments | Manufacturer | Model No. | Serial No. | Frequency Range | Cal. Due Date |
|---------------------|-----------------|--------------------|------------|---------------------------------------|---------------|
| Spectrum Analyzer | Rohde & Schwarz | FSEK30 | 100077 | 20 Hz – 40 GHz with external mixer | Aug 10, 2010 |
| Spectrum Analyzer | Rohde & Schwarz | ESU40 | 100037 | 20 Hz – 40 GHz | Feb 17, 2010 |
| Amplifier | Hewlett Packard | 8449B | 3008A00769 | 1 – 26 GHz | Jun 1, 2010 |
| Attenuator | Narda | 4768-10 | - | DC – 40 GHz | |
| Biconilog Antenna | EMCO | 3142 | 1005 | 26 – 2000 MHz | Apr 18, 2010 |
| DC Block | Hewlett Packard | 11742A | 12460 | 0.045 – 26.5 GHz | |
| EMI Receiver | Hewlett Packard | 85462A | 3650A00371 | 9 kHz – 6.5 GHz | Jan 5, 2010 |
| High Pass Filter | K & L | 11SH10-1000/T12000 | 4 | Cut off 2.4 GHz | |
| Horn Antenna | EMCO | 3115 | 5061 | 1 – 18 GHz | Sep 21, 2010 |
| L.I.S.N. | EMCO | 3825/2 | 8907-1531 | 10 kHz – 100 MHz | Mar 28, 2010 |
| RF Filter Selection | Hewlett Packard | 85460A | 3330A00149 | | Jan 5, 2010 |

ULTRATECH GROUP OF LABS

3000 Bristol Circle, Oakville, Ontario, Canada L6H 6G4
 Tel. #: 905-829-1570, Fax. #: 905-829-8050, Email: vic@ultratech-labs.com, Website: <http://www.ultratech-labs.com>

File #: RIM-029F15B
 October 7, 2009

All test results contained in this engineering test report are traceable to National Institute of Standards and Technology (NIST)

EXHIBIT 7. MEASUREMENT UNCERTAINTY

The measurement uncertainties stated were calculated in accordance with the requirements of NIST Technical Note 1297 and NIS 81 (1994)

7.1. LINE CONDUCTED EMISSION MEASUREMENT UNCERTAINTY

| CONTRIBUTION (Line Conducted) | PROBABILITY DISTRIBUTION | UNCERTAINTY (dB) | |
|--|-----------------------------|------------------|-------------|
| | | 9-150 kHz | 0.15-30 MHz |
| EMI Receiver specification | Rectangular | ± 1.5 | ± 1.5 |
| LISN coupling specification | Rectangular | ± 1.5 | ± 1.5 |
| Cable and Input Transient Limiter calibration | Normal (k=2) | ± 0.3 | ± 0.5 |
| Mismatch: Receiver VRC $\Gamma_1 = 0.03$ LISN VRC $\Gamma_R = 0.8(9 \text{ kHz}) 0.2 (30 \text{ MHz})$ Uncertainty limits $20\text{Log}(1+\Gamma_1\Gamma_R)$ | U-Shaped | ± 0.2 | ± 0.3 |
| System repeatability | Std. deviation | ± 0.2 | ± 0.05 |
| Repeatability of EUT | -- | -- | -- |
| Combined standard uncertainty | Normal | ± 1.25 | ± 1.30 |
| Expanded uncertainty U | Normal (k=2) | ± 2.50 | ± 2.60 |

Sample Calculation for Measurement Accuracy in 150 kHz to 30 MHz Band:

$$u_c(y) = \sqrt{\sum_{i=1}^m u_i^2(y)} = \pm \sqrt{(1.5^2 + 1.5^2)/3 + (0.5/2)^2 + (0.05/2)^2 + 0.35^2} = \pm 1.30 \text{ dB}$$

$$U = 2u_c(y) = \pm 2.6 \text{ dB}$$

7.2. RADIATED EMISSION MEASUREMENT UNCERTAINTY

| CONTRIBUTION (Radiated Emissions) | PROBABILITY DISTRIBUTION | UNCERTAINTY (\pm dB) | |
|---|-----------------------------|-------------------------|---------------|
| | | 3 m | 10 m |
| Antenna Factor Calibration | Normal (k=2) | ± 1.0 | ± 1.0 |
| Cable Loss Calibration | Normal (k=2) | ± 0.3 | ± 0.5 |
| EMI Receiver specification | Rectangular | ± 1.5 | ± 1.5 |
| Antenna Directivity | Rectangular | +0.5 | +0.5 |
| Antenna factor variation with height | Rectangular | ± 2.0 | ± 0.5 |
| Antenna phase center variation | Rectangular | 0.0 | ± 0.2 |
| Antenna factor frequency interpolation | Rectangular | ± 0.25 | ± 0.25 |
| Measurement distance variation | Rectangular | ± 0.6 | ± 0.4 |
| Site imperfections | Rectangular | ± 2.0 | ± 2.0 |
| Mismatch: Receiver VRC $\Gamma_1 = 0.2$ Antenna VRC $\Gamma_R = 0.67(\text{Bi}) 0.3 (\text{Lp})$ Uncertainty limits $20\text{Log}(1 \pm \Gamma_1 \Gamma_R)$ | U-Shaped | +1.1 -1.25 | ± 0.5 |
| System repeatability | Std. Deviation | ± 0.5 | ± 0.5 |
| Repeatability of EUT | | - | - |
| Combined standard uncertainty | Normal | +2.19 / -2.21 | +1.74 / -1.72 |
| Expanded uncertainty U | Normal (k=2) | +4.38 / -4.42 | +3.48 / -3.44 |

Calculation for maximum uncertainty when 3m biconical antenna including a factor of k = 2 is used:

$$U = 2u_c(y) = 2x(+2.19) = +4.38 \text{ dB} \quad \text{And} \quad U = 2u_c(y) = 2x(-2.21) = -4.42 \text{ dB}$$

EXHIBIT 8. MEASUREMENT METHODS

8.1. GENERAL TEST CONDITIONS

8.1.1. Test Conditions

- The measurement shall be made in the operational mode producing the largest emission in the frequency band being investigated consistent with normal applications.
- An attempt shall be made to maximize the detected radiated emissions, for example moving cables of the equipment, rotating the equipment by 360° and moving the measuring receiving antenna up and down within 1 to 4 meters high.
- Where appropriate, a single tone or a bit stream shall be used to modulate the receiver. The manufacturer shall define the modulation with the highest emission in transmit mode.

8.1.2. Method of Measurements - AC Mains Conducted Emissions

- AC Mains conducted emissions measurements were performed in accordance with the standard against appropriate limits for each detector function.
- The test was performed in the shielded room, 16'(L) by 16'(W) by 12'(H).
- The test was performed were made over the frequency range from 150 kHz to 30 MHz to determine the line-to-ground radio noise voltage which was conducted from the EUT power-input terminals that were directly connected to a public power network.
- The EUT normally received power from another device that connects to the public utility ac power lines, measurements would be made on that device with the EUT in operation to ensure that the device continues to comply with the appropriate limits while providing the EUT with power.
- If the EUT operates only from internal or dedicated batteries, with no provisions for connection to the public utility ac power lines, AC Mains conducted measurements are not required.
- Table-top devices were placed on a platform of nominal size 1 m by 1.5m raised 80 cm above the conducting ground plane.
- The EUT current-carrying power lead, except the ground (safety) lead, was individually connected through a LISN to the power source. All unused 50-Ohm connectors of the LISN was terminated in 50-ohm when not connected to the measuring instruments.
- The line cord of the EUT connected to one LISN which was connected to the measuring instrument. Those power cords for the units of devices not under measurement were connected to a separate multiple ac outIFCC. Drawings and photographs of typically conducted emission test setups were shown in the Test Report. Each current-carrying conductor of the EUT shall be individually tested.
- The EUT was normally operated with a ground (safety) connection, the EUT was connected to the ground at the LISN through a conductor provided in the lead from the ac power mains to the LISN.
- The excess length of the power cord was folded back and forth in an 8-shape on a wooden strip with a vertical prong located on the top of the LISN case.
- The EUT was set-up in its typical configuration and operated in its various modes as described in this test report.
- A preliminary scan was made by using spectrum analyzer system with the detector function set to PEAK mode (9 KHz RBW, VBW > RBW), frequency span 150KHz - 30MHz.

- The maximum conducted emission for a given mode of operation was found by using the following step-by-step procedure:
 - Step 1. Monitor the frequency range of interest at a fixed EUT azimuth.
 - Step 2. Manipulate the system cables and peripheral devices to produce highest amplitude signal relative to the limit. Note the amplitude and frequency of the suspect signal.
 - Step 3. The effects of various modes of operation is examined. This is done by varying equipment operation modes as step 2 is being performed.
 - Step 4. After completing step 1 through 3, record EUT and peripheral device configuration, mode of operation, cable configuration, signal levels and frequencies for final test.

- Each highest signal level at the maximized test configuration was zoomed in a small frequency span on the spectrum analyzer's display (the manipulation of cables and peripheral devices and EUT operation modes might have to be repeated to obtain the highest signal level with the spectrum analyzer set to PEAK detector mode 9 KHz RBW and VBW > RBW). The spectrum analyzer was then set to CISPR QUASI-PEAK detector mode (10 KHz RBW, 1 MHz VBW) and AVERAGE detector mode (9 kHz RBW, 1 Hz VBW). The final highest RF signal levels and frequencies were record.

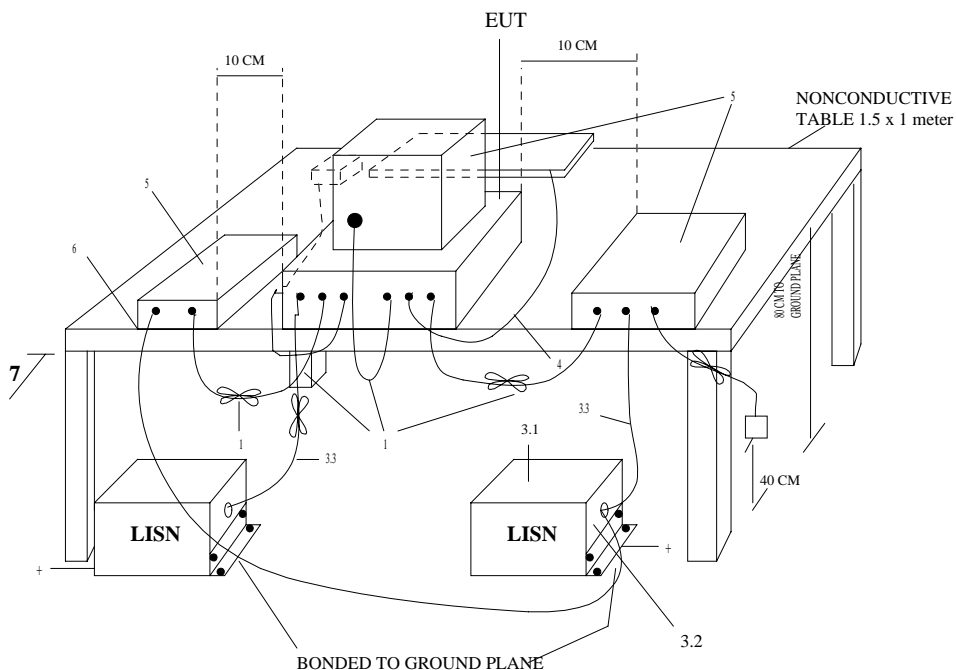

+LISNs may have to be moved to the side to meet 3.3 below

LEGEND:

1. Interconnecting cables that hang closer than 40 cm to the ground plane shall be folded back at forth forming a bundle 30 to 40 cm long, hanging approximately in the middle between ground plane and table.
2. I/O cables that are connected to a peripheral shall be bundled in center. The end of the cable may be terminated if required using correct terminating impedance. The total length shall not exceed 1m.
3. EUT connected to one LISN. Unused LISN connectors shall be terminated in 50 Ohm. LISN can be placed on top of, or immediately beneath, ground plane.
 - 3.1 All other equipment powered from second LISN.
 - 3.2 Multiple outlet strip can be used for multiple power cords of non-EU equipment.
 - 3.3 LISN at least 80 cm from nearest part of EUT chassis.
4. Cables of hand-operated devices, such as keyboards, mouses, etc., have to be placed as close as possible to the host.
5. Non-EUT components being tested.
6. Rear of EUT, including peripherals, shall be all aligned and flush with rear of tabletop.
7. Rear of tabletop shall be 40 cm removed from a vertical conducting plane that is bonded to the floor ground plane (see 5.2)

Tabletop Equipment Conducted Emissions

ULTRATECH GROUP OF LABS

3000 Bristol Circle, Oakville, Ontario, Canada L6H 6G4
Tel. #: 905-829-1570, Fax. #: 905-829-8050, Email: vic@ultratech-labs.com, Website: <http://www.ultratech-labs.com>

File #: RIM-029F15B
October 7, 2009

All test results contained in this engineering test report are traceable to National Institute of Standards and Technology (NIST)

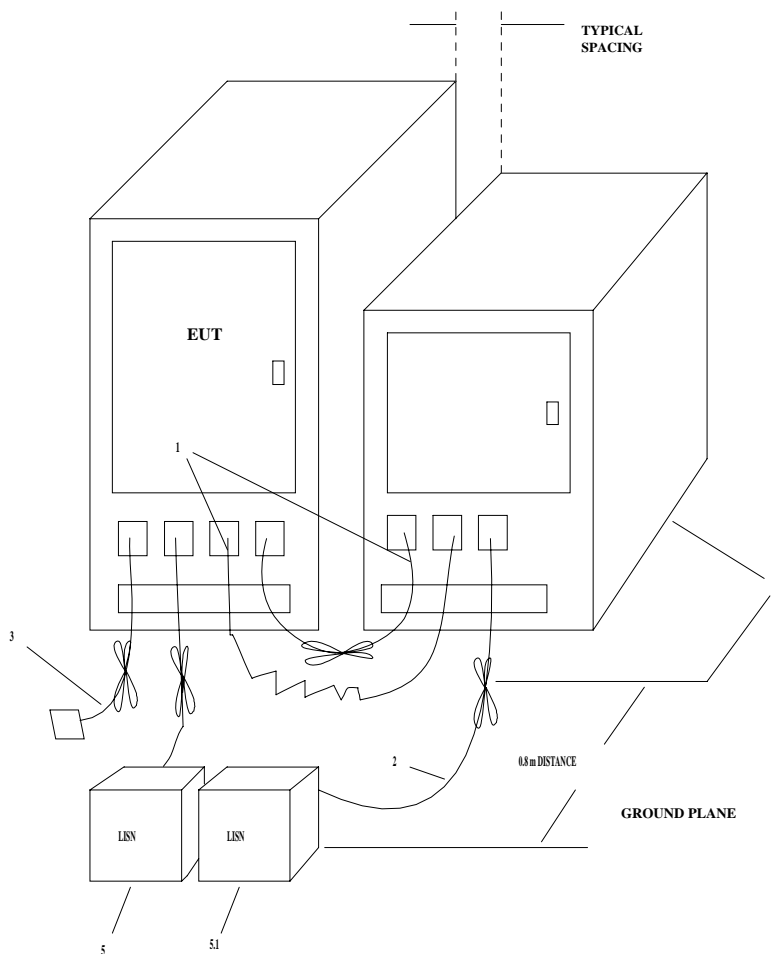

LEGEND:

1. Excess I/O cables shall be bundled in center. If bundling is not possible, the cables shall be arranged in serpentine fashion. Bundling shall not exceed 40 cm in length.
2. Excess power cords shall be bundled in the center or shortened to appropriated length.
3. I/O cables that are not connected to a peripheral shall be bundled in the center. The end of the cable may be terminated if required using correct terminating impedance. If bundling is not possible, the cable shall be arranged in serpentine fashion.
4. EUT and all cables shall be insulated from ground plane by 3 to 12 mm of insulating material.
5. EUT connected to one LISN. LISN can be placed on top of, or immediately beneath, ground plane.
- 5.1 All other equipment powered from second LISN.

Floor-Standing Equipment Conducted Emissions

8.1.3. Method of Measurements - Electric Field Radiated Disturbance

- The radiated emission measurements were performed at the UltraTech's 3 Meter Open Field Test Site (OFTS) situated in the Town of Oakville, province of Ontario. The Attenuation Characteristics of OFTS have been filed to FCC, Industry Canada, ACA/Austel, NVLap and ITI.
- Radiated emissions measurements were made using the following test instruments:
 1. Calibrated EMCO BiconiLog antenna in the frequency range from 30 MHz to 2000 MHz.
 2. Calibrated Emco Horn antennas in the frequency range above 1000 MHz (1GHz - 40 GHz).
 3. Calibrated Advantest spectrum analyzer and pre-selector. In general, the spectrum analyzer would be used as follows:
 - The rf electric field levels were measured with the spectrum analyzer set to PEAK detector (120 KHz VBW and $VBW \geq RBW$).
 - If any rf emission was observed to be a broadband noise, the spectrum analyzer's CISPR QUASI-PEAK detector (120 KHz RBW and $VBW \geq RBW$) was then set to measure the signal level.
 - If the signal being measured was narrowband and the ambient field was broadband, the bandwidth of the spectrum analyzer was reduced.
- The EUT was set-up in its typical configuration and operated in its various modes as described in this test report.
- The frequencies of emissions was first detected. Then the amplitude of the emissions was measured at the specified measurement distance using required antenna height, polarization, and detector characteristics.
- During this process, cables and peripheral devices were manipulated within the range of likely configuration.
- For each mode of operation required to be tested, the frequency spectrum was monitored. Variations in antenna heights (from 1 meter to 4 meters above the ground plane), antenna polarization (horizontal plane and vertical plane), cable placement and peripheral placement were explored to produce the highest amplitude signal relative to the limit.

The maximum radiated emission for a given mode of operation was found by using the following step-by-step procedure:

Step 1: Monitor the frequency range of interest at a fixed antenna height and EUT azimuth.

Step 2: Manipulate the system cables to produce highest amplitude signal relative to the limit. Note the amplitude and frequency of the suspect signal.

Step 3: Rotate the EUT 360 degrees to maximize the suspected highest amplitude signal. If the signal or another at a different frequency is observed to exceed the previously noted highest amplitude signal by 1 dB or more, go back to the azimuth and repeat Step 2. Otherwise, orient the EUT azimuth to repeat the highest amplitude observation and proceed.

Step 4: Move the antenna over its full allowed range of travel (1 to 4 meters) to maximize the suspected highest amplitude signal. If the signal or another at a different frequency is observed to exceed the previously noted highest amplitude signal by 1 dB or more, return to Step 2 with the highest amplitude observation and proceed.

Step 5: Change the polarization of the antenna and repeat Step 2 through 4. Compare the resulting suspected highest amplitude signal with that found for the other polarization. Select and note the higher of the two signals. This signal is termed the highest observed signal with respect to the limit for this EUT operational mode.

Step 6: The effects of various modes of operation is examined. This is done by varying the equipment modes as steps 2 through 5 are being performed.

Step 7: After completing steps 1 through 6, record the final highest emission level, frequency, antenna polarization and detector mode of the measuring instrument.

Calculation of Field Strength:

The field strength is calculated by adding the calibrated antenna factor and cable factor, and subtracting the Amplifier gain (if any) from the measured reading. The basic equation with a sample calculation is as follows:

$$FS = RA + AF + CF - AG$$

Where FS = Field Strength
RA = Receiver/Analyzer Reading
AF = Antenna Factor
CF = Cable Attenuation Factor
AG = Amplifier Gain

Example: If a receiver reading of 60.0 dBμV is obtained, the antenna factor of 7.0 dB/m and cable factor of 1.0 dB are added, and the amplifier gain of 30 dB is subtracted. The actual field strength will be:

Field Level = 60 + 7.0 + 1.0 - 30 = 38.0 dBμV/m.

Field Level = $10^{(38/20)}$ = 79.43 μV/m.

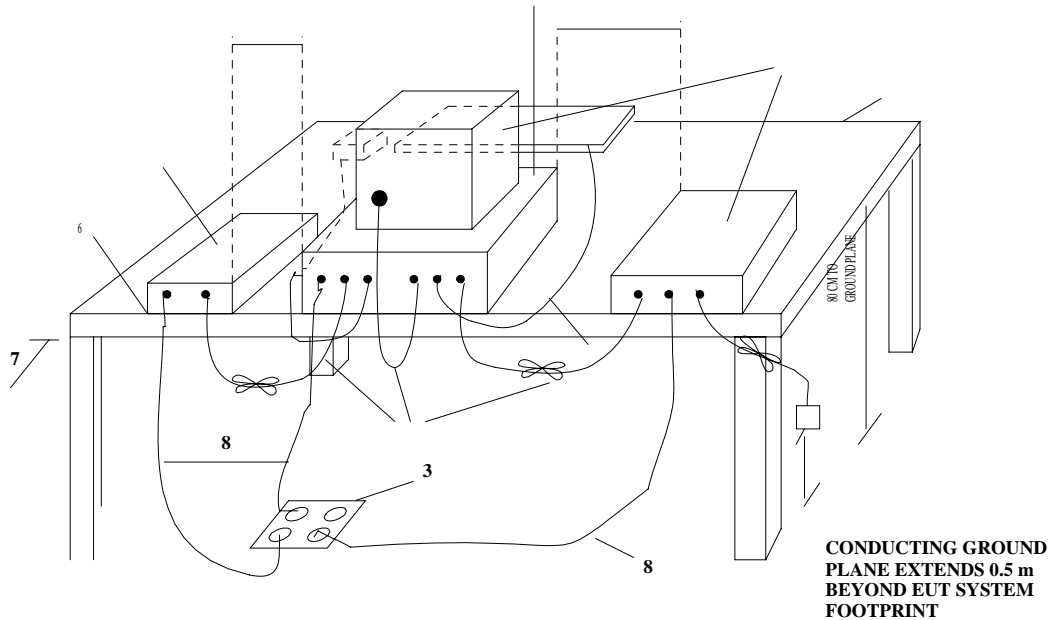

LEGEND:

1. Interconnecting cables that hang closer than 40 cm to the ground plane shall be folded back and forth forming a bundle 30 to 40 cm long, hanging approximately in the middle between ground plane and table.
2. I/O cables that are connected to a peripheral shall be bundled in center. The end of the cable may be terminated if required using correct terminating impedance. The total length shall not exceed 1m.
3. If LISNs are kept in the test setup for radiated emissions, it is preferred that they be installed under the ground plane with the receptacle flush with the ground plane.
4. Cables of hand-operated devices, such as keyboards, mouses, etc., have to be placed as close as possible to the controller.
5. Non-EUT components of EUT system being tested.
6. The rear of all components of the system under test shall be located flush with the rear of the table.
7. No vertical conducting wall used.
8. Power cords drape to the floor and are routed over to receptacle.

Tabletop Equipment Radiated Emissions

ULTRATECH GROUP OF LABS

3000 Bristol Circle, Oakville, Ontario, Canada L6H 6G4
Tel. #: 905-829-1570, Fax. #: 905-829-8050, Email: vic@ultratech-labs.com, Website: <http://www.ultratech-labs.com>

File #: RIM-029F15B

October 7, 2009

All test results contained in this engineering test report are traceable to National Institute of Standards and Technology (NIST)

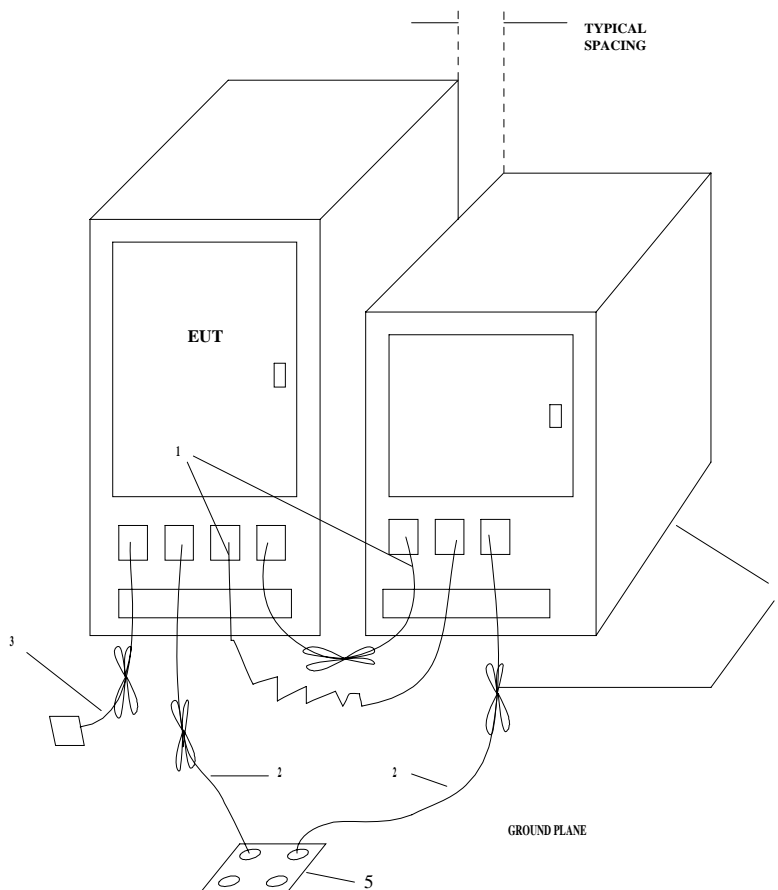

LEGEND:

1. Excess I/O cables shall be bundled in center. If bundling is not possible, the cables shall be arranged in serpentine fashion.
2. Excess power cords shall be bundled in the center or shortened to appropriated length.
3. I/O cables that are not connected to a peripheral shall be bundled in the center. The end of the cable may be terminated if required using correct terminating impedance. If bundling is not possible, the cable shall be arranged in serpentine fashion.
4. EUT and all cables shall be insulated from ground plane by 3 to 12 mm of insulating material.
5. If LISNs are kept in the test setup for radiated emissions, it is preferred that they be installed under the ground plane with the receptacle flush with the ground plane.

Floor-Standing Equipment Radiated Emissions

ULTRATECH GROUP OF LABS

3000 Bristol Circle, Oakville, Ontario, Canada L6H 6G4
Tel. #: 905-829-1570, Fax. #: 905-829-8050, Email: vic@ultratech-labs.com, Website: <http://www.ultratech-labs.com>

File #: RIM-029F15B

October 7, 2009

All test results contained in this engineering test report are traceable to National Institute of Standards and Technology (NIST)

EXHIBIT 9. LABELLING & VERIFICATION REQUIREMENTS

9.1. SECTION 15.19 – LABELLING REQUIREMENTS

A device subject to verification shall be labelled as follows:

This device complies with Part 15 of the FCC Rules. Operation is subject to the following two conditions: (1) this device may not cause harmful interference and (2) this device must accept any interference received, including interference that may cause undesired operation.

9.2. SECTIONS 15.21 & 15.105 – INFORMATION TO USER

The users manual or instruction manual for an intentional or unintentional radiator shall caution the user that changes or modifications not expressly approved by the party responsible for compliance could void the user's authority to operate the equipment.

- (a) For a Class B digital device or peripheral, the instructions furnished the user shall include the following or similar statement, placed in a prominent location in the text of the manual.

NOTE: This equipment has been tested and found to comply with the limits for a Class B digital device, pursuant to Part 15 of the FCC Rules. These limits are designed to provided reasonable protection against harmful interference when the equipment is operated in a commercial environment. This equipment generates, uses, and can radiate radio frequency energy and, if not installed and used in accordance with the instruction manual, may cause harmful interference to radio communications. Operation of this equipment in a residential area is likely to cause harmful interference in which case the user will be required to correct the interference at his own expense.

Warning: Changes or modifications not expressly approved by <manufacturer> could void the user's authority to operate the equipment.

9.3. SECTION 2.902 - VERIFICATION

(a) Verification is a procedure where the manufacturer makes measurements or takes the necessary steps to insure that the equipment complies with the appropriate technical standards. Submittal of a sample unit or representative data to the Commission demonstrating compliance is not required unless specifically requested by the Commission pursuant to § 2.957, of this part.

(b) Verification attaches to all items subsequently marketed by the manufacturer or importer which are identical as defined in § 2.908 to the sample tested and found acceptable by the manufacturer.

9.4. SECTION 2.909 – RESPONSIBLE PARTY

The following parties are responsible for the compliance of radio frequency equipment with the applicable standards:

(a) In the case of equipment which requires the issuance by the Commission of a grant of equipment authorization, the party to whom that grant of authorization is issued (the grantee) If the radio frequency equipment is modified by any party other than the grantee and that party is not working under the authorization of the grantee pursuant to §2.929(b), the party performing the modification is responsible for compliance of the product with the applicable administrative and technical provisions in this chapter.

(b) In the case of equipment subject to authorization under the verification procedure, the manufacturer or, in the case of imported equipment, the importer. If subsequent to manufacture and importation, the radio frequency equipment is modified by any party not working under the authority of the responsible party, the party performing the modification becomes the new responsible party.

(c) In the case of equipment subject to authorization under the Declaration of Conformity procedure:

(1) The manufacturer or, if the equipment is assembled from individual component parts and the resulting system is subject to authorization under a Declaration of Conformity, the assembler.

(2) If the equipment, by itself, is subject to a Declaration of Conformity and that equipment is imported, the importer.

(3) Retailers or original equipment manufacturers may enter into an agreement with the responsible party designated in paragraph (c)(1) or (c)(2) of this section to assume the responsibilities to ensure compliance of equipment and become the new responsible party.

(4) If the radio frequency equipment is modified by any party not working under the authority of the responsible party, the party performing the modifications, if located within the U.S., or the importer, if the equipment is imported subsequent to the modifications, becomes the new responsible party.

(d) If, because of modifications performed subsequent to authorization, a new party becomes responsible for ensuring that a product complies with the technical standards and the new party does not obtain a new equipment authorization, the equipment shall be labelled, following the specifications in § 2.925(d), with the following: "This product has been modified by [insert name, address and telephone number of the party performing the modifications]."

9.5. SECTION 2.945 – SAMPLING TEST OF EQUIPMENT COMPLIANCE

The Commission will, from time to time, request the responsible party to submit equipment subject to this chapter to determine the extent to which subsequent production of such equipment continues to comply with the data filed by the applicant (or on file with the responsible party for equipment subject to notification or a Verification). Shipping costs to the Commission's laboratory and return shall be borne by the responsible party.

9.6. SECTION 2.946 – PENALTY FOR FAILURE TO PROVIDE TEST SAMPLES AND DATA

(a) Any responsible party, as defined in § 2.909, or any party who markets equipment subject to the provisions of this chapter, shall provide test sample(s) or data upon request by the Commission. Failure to comply with such a request within 14 days may be cause for forfeiture, pursuant to § 1.80 of this chapter, or other administrative sanctions such as suspending action on any applications for equipment authorization submitted by such party while the matter is being resolved.

(b) The Commission may consider extensions of time upon submission of a showing of good cause.

9.7. SECTION 2.952 - LIMITATION ON VERIFICATION

(a) Verification signifies that the manufacturer or importer has determined that the equipment has been shown to be capable of compliance with the applicable technical standards if no unauthorized change is made in the equipment and if the equipment is properly maintained and operated. Compliance with these standards shall not be construed to be a finding by the manufacturer or importer with respect to matters not encompassed by the Commission's rules.

(b) Verification of the equipment by the manufacturer or importer is effective until a termination date is otherwise established by the Commission.

(c) No person shall, in any advertising matter, brochure, etc., use or make reference to a verification in a deceptive or misleading manner or convey the impression that such verification reflects more than a determination by the manufacturer or importer that the device or product has been shown to be capable of compliance with the applicable technical standards of the Commission's Rules.

9.8. SECTION 2.953 - RESPONSIBILITY FOR COMPLIANCE

(a) In verifying compliance, the responsible party, as defined in § 2.909 warrants that each unit of equipment marketed under the verification procedure will be identical to the unit tested and found acceptable with the standards and that the records maintained by the responsible party continue to reflect the equipment being produced under such verification within the variation that can be expected due to quantity production and testing on a statistical basis.

(b) The importer of equipment subject to verification may upon receiving a written statement from the manufacturer that the equipment complies with the appropriate technical standards rely on the manufacturer or independent testing agency to verify compliance. The test records required by § 2.955 however should be in the English language and made available to the Commission upon a reasonable request, in accordance with § 2.956.

(c) In the case of transfer of control of equipment, as in the case of sale or merger of the grantee, the new manufacturer or importer shall bear the responsibility of continued compliance of the equipment.

(d) Verified equipment shall be reverified if any modification or change adversely affects the emanation characteristics of the modified equipment. The party designated in § 2.909 bears responsibility for continued compliance of subsequently produced equipment.

9.9. SECTION 2.954 - IDENTIFICATION

Devices subject only to verification shall be uniquely identified by the person responsible for marketing or importing the equipment within the United States. However, the identification shall not be of a format which could be confused with the FCC Identifier required on certified, notified or type accepted equipment. The importer or manufacturer shall maintain adequate identification records to facilitate positive identification for each verified device.

9.10. SECTION 2.955 - RETENTION OF RECORDS

(a) For each equipment subject to verification, the responsible party, as shown in §2.909 shall maintain the records listed as follows:

- (1) A record of the original design drawings and specifications and all changes that have been made that may affect compliance with the requirements of § 2.953.
- (2) A record of the procedures used for production inspection and testing (if tests were performed) to insure the conformance required by § 2.953. (Statistical production line emission testing is not required.)
- (3) A record of the measurements made on an appropriate test site that demonstrates compliance with the applicable regulations in this chapter.
The record shall:
 - (i) Indicate the actual date all testing was performed;
 - (ii) State the name of the test laboratory, company, or individual performing the verification testing. The Commission may request additional information regarding the test site, the test equipment or the qualifications of the company or individual performing the verification tests;
 - (iii) Contain a description of how the device was actually tested, identifying the measurement procedure and test equipment that was used;
 - (iv) Contain a description of the equipment under test (EUT) and support equipment connected to, or installed within, the EUT;
 - (v) Identify the EUT and support equipment by trade name and model number and, if appropriate, by FCC Identifier and serial number;
 - (vi) Indicate the types and lengths of connecting cables used and how they were arranged or moved during testing;
 - (vii) Contain at least two drawings or photographs showing the test set-up for the highest line conducted emission and showing the test set-up for the highest radiated emission. These drawings or photographs must show enough detail to confirm other information contained in the test report. Any photographs used must be focused originals without glare or dark spots and must clearly show the test configuration used;
 - (viii) List all modifications, if any, made to the EUT by the testing company or individual to achieve compliance with the regulations in this chapter;
 - (ix) Include all of the data required to show compliance with the appropriate regulations in this chapter; and
 - (x) Contain, on the test report, the signature of the individual responsible for testing the product along with the name and signature of an official of the responsible party, as designated in § 2.909.

ULTRATECH GROUP OF LABS

3000 Bristol Circle, Oakville, Ontario, Canada L6H 6G4
Tel. #: 905-829-1570, Fax. #: 905-829-8050, Email: vic@ultratech-labs.com, Website: <http://www.ultratech-labs.com>

File #: RIM-029F15B
October 7, 2009

All test results contained in this engineering test report are traceable to National Institute of Standards and Technology (NIST)

(4) For equipment subject to the provisions in part 15 of this chapter, the records shall indicate if the equipment was verified pursuant to the transition provisions contained in § 15.37 of this chapter.

(b) The records listed in paragraph (a) of this section shall be retained for two years after the manufacture of said equipment item has been permanently discontinued, or until the conclusion of an investigation or a proceeding if the manufacturer or importer is officially notified that an investigation or any other administrative proceeding involving his equipment has been instituted.

9.11. SECTION 2.956 - FCC INSPECTION & SUBMISSION OF EQUIPMENT FOR TESTING

(a) Each responsible party shall upon receipt of reasonable request:

(1) Submit to the Commission the records required by § 2.955.

(2) Submit one or more sample units for measurements at the Commission's Laboratory.

(i) Shipping costs to the Commission's Laboratory and return shall be borne by the responsible party.

(ii) In the event the responsible party believes that shipment of the sample to the Commission's Laboratory is impractical because of the size or weight of the equipment, or the power requirement, or for any other reason, the responsible party may submit a written explanation why such shipment is impractical and should not be required.

(b) Requests for the submission of the records in § 2.955 or for the submission of sample units are covered under the provisions of § 2.946.