

EMI Test Report

Tested in accordance with
Federal Communications Commission (FCC)
Personal Communications Services
CFR 47, Parts 2, 22 and 24
and
Industry Canada, RSS-133 and RSS-129



Research In Motion Limited

REPORT NO.: RIM-0060-0309-02

PRODUCT MODEL NO: RAN21CN
TYPE NAME: BlackBerry Wireless Handheld
FCC ID: L6ARAN21CN
IC: 2503A-RAN21CN

Date: _____ 25 November 2003 _____

Declaration**Statement of Performance:**

The BlackBerry Wireless Handheld, model RAN21CN ASY-06708-001 when configured and operated per RIM's operation instructions, performs within the requirements of the test standards.

Declaration:

We hereby certify that:

The test data reported herein is an accurate record of the performance of the sample(s) tested.

The test equipment used was suitable for the tests performed and within the manufacturers published specifications and operating parameters.

The test methods were consistent with the methods described in the relevant standards.

Tested by

Maurice Battler
Compliance Specialist

Date: 25 November 2003



Masud S. Attayi, P.Eng.
Senior Compliance and Certification Engineer

Date: 04 December 2003

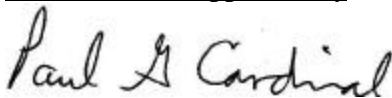
Reviewed and Approved by:

Paul G. Cardinal, Ph.D.
Manager, Compliance and Certification

Date: 05 December 2003

Table of Contents

A) Scope	Pg. 3
B) Product Identification	Pg. 3
C) Support Equipment Used for Testing of the EUT	Pg. 3
D) Test Voltage	Pg. 4
E) Test Results Chart	Pg. 4
F) Modifications to EUT	Pg. 4
G) Summary of Results	Pg. 5
H) Compliance Test Equipment Used	Pg. 7

Appendix 1 Conducted Emissions Test Data/Plots

Appendix 2 Conducted RF Output Power Test Data

Appendix 3 Frequency Stability Test Data

Appendix 4 Radiated Emissions Test Data

A) Scope

This report details the results of compliance tests which were performed in accordance to the requirements of:

FCC CFR 47 Part 2, Oct. 1, 2000

FCC CFR 47 Part 22, Subpart H, Cellular Radiotelephone Services, Oct. 1, 2000

FCC CFR 47 Part 24 Subpart E, Broadband PCS, Oct 1. 2000

Industry Canada, RSS-129 Issue 2, Sept. 25/99, 800 MHz Dual-Mode CDMA Cellular Telephones

Industry Canada, RSS-133 Issue 2, Rev. 1 Nov. 6/1999, 2.0 GHz Personal Communications Services

B) Product Identification

The equipment under test (EUT) was tested at the Research In Motion (RIM) EMI test facility, located at:

305 Phillip Street

Waterloo, Ontario

Canada, N2L 3W8

Phone: 519 888 7465

Fax: 519 888 6906

Web Site: www.rim.net

The testing began on November 6, 2003 and completed on November 23, 2003. The sample equipment under test (EUT) included:

- 1a BlackBerry Wireless Handheld, model number RAN21CN, ASY-06708-001, identification number E2PRF08, FCC ID L6ARAN21CN, IC: 2503A-RAN21CN.
- 1b BlackBerry Wireless Handheld, model number RAN21CN, ASY-06708-001, identification number E2PRF05, FCC ID L6ARAN21CN, IC: 2503A-RAN21CN.

The transmit frequency bands for the Handheld are: Cellular 824 to 849 MHz and PCS 1850 to 1910 MHz.

C) Support Equipment Used for the Testing of the EUT

- 1) Agilent Wireless Communication Test Set, model 8960, serial number US41070110
- 2) Agilent Wireless Communication Test Set, model 8960, serial number 6B41070272
- 3) DC Power Supply, H/P, model 6632B, serial number US37472178

D) Test Voltage

The ac input voltage was 120 volts, 60 Hz where applicable. This configuration was per RIM's specifications.

E) Test Results Chart

SPECIFICATION	Test Type	MEETS REQUIREMENTS	Performed By
FCC CFR 47 Part 22, Subpart H IC RSS-129	Radiated Spurious/harmonic Emissions, ERP, LO	Yes	Masud Attayi
FCC CFR 47 Part 22, Subpart H IC RSS-129	Conducted Emissions, Occupied Bandwidth, Frequency Stability	Yes	Maurice Battler
FCC CFR 47 Part 24, Subpart E IC RSS-133	Radiated Spurious/harmonic Emissions, EIRP, LO	Yes	Masud Attayi
FCC CFR 47 Part 24, Subpart E IC RSS-133	Conducted Emissions, Occupied Bandwidth, Frequency Stability	Yes	Maurice Battler

F) Modifications to EUT

No modifications were required to the EUT.

G) Summary of Results

- 1) The EUT passed the Conducted Spurious Emissions requirements in the Cellular band as per 47 CFR 22.917, CFR 22.901(d) and RSS-129. The EUT was measured on the low, middle and high channels. The frequency range investigated was from 10 MHz to 20 GHz.
See APPENDIX 1 for the test data.
- 2) The EUT passed the Conducted Spurious Emissions requirements in the PCS band as per 47 CFR 2.1057, CFR 24.238 and RSS-133. The EUT was measured on the low, middle and high channels. The frequency range investigated was from 10 MHz to 20 GHz.
See APPENDIX 1 for the test data.
- 3) The EUT passed the Occupied Bandwidth requirements in the Cellular band as per 47 CFR 2.202, CFR 22.917 and RSS-129. The channels measured were low, middle and high.
See APPENDIX 1 for the test data.
- 4) The EUT passed the Occupied Bandwidth and channel mask requirements in the PCS band as per 47 CFR 2.202, CFR 24.238 and RSS-133. The channels measured were low, middle and high.
See APPENDIX 1 for the test data.
- 5) The EUT passed the Conducted RF Output Power requirements for both the Cellular and PCS bands. The channels measured were low, middle and high.
See APPENDIX 2 for the test data.
- 6) The EUT passed the Frequency Stability vs. Temperature and Voltage requirements for Cellular band as per 22.917 and RSS-129.
The maximum frequency error measured was less than 0.1 ppm.
The temperature range was from -30°C to +60°C in 10° temperature steps. The EUT was measured on low, middle and high channels at each temperature step. The EUT was measured at low (3.5 volts), nominal (3.8 volts) and high (4.1 volts) dc input voltage at each temperature step and channel at maximum output power.
See APPENDIX 3 for the test data.
- 7) The EUT passed the Frequency Stability vs. Temperature and Voltage requirements for the PCS band as per 24.235 and RSS-133. The maximum frequency error measured was less than 0.1 ppm.
The temperature range was from -30°C to +60°C in 10 degree temperature steps. The EUT was measured on low, middle and high channels at each temperature step. The EUT was measured at low (3.5 volts), nominal (3.8 volts) and high (4.1 volts) dc input voltage at each temperature step and channel at maximum output power.
See APPENDIX 3 for the test data.

- 8) The radiated spurious emissions/harmonics and ERP/EIRP were measured for both Cellular and PCS bands. The results are within the limits. The EUT was placed on a nonconductive wooden table, 80 cm high plus 20 cm high styrofoam on top of the table which was positioned on a remotely rotatable turntable. The EUT height of one metre was set in order to align it with the lowest height of the receiving antenna. The test distance used between the EUT and the receiving antenna was three metres. At this point the emissions were maximized by elevating the antenna in the range of 1 to 4 metres. The turntable was rotated to determine the azimuth of the peak emissions. The maximum emissions level was recorded. The measurements were performed in a semi-anechoic chamber. The semi-anechoic chamber FCC registration number is **778487** and the Industry Canada file number is **IC4240**. The EUT was measured on the low, middle and high channels.

The highest ERP in the Cellular band measured was 25.8 dBm at 837.49 MHz (channel 417).
The highest EIRP in the PCS band measured was 24.8 dBm at 1880.00 MHz (channel 600).
To view the test data see APPENDIX 4.

The radiated carrier harmonics were measured up to the 10th harmonic for low, middle and high channels in the Cellular and PCS bands.

The Cellular radiated carrier harmonic emissions were in the noise floor (NF).

The lowest test margin for the PCS band was 20.2 dB below the limit at 3760.0 MHz.

To view the test data see APPENDIX 4.

The EUT's RF local oscillator emissions were measured in the Cellular band on the low, middle and high channels (1013, 417 and 777) in the standalone upright position. Both the horizontal and vertical polarizations were measured. The Cellular RF local oscillator emissions were in the NF.

The EUT's RF local oscillator emissions were measured in the PCS band on the low, middle and high channels (25, 600 and 1175) in the standalone upright position. Both the horizontal and vertical polarizations were measured. The PCS RF local oscillator emissions were in the NF.

Sample Calculation:

Field Strength (dB μ V/M) is calculated as follows:

$$FS = \text{Measured Level (dB}\mu\text{V)} + \text{A.F. (dB/m)} + \text{Cable Loss (dB)} - \text{Preamp (dB)} + \text{Filter Loss (dB)}$$

Measurement Uncertainty ± 4.0 dB

H) Compliance Test Equipment Used

<u>UNIT</u>	<u>MANUFACTURER</u>	<u>MODEL / SERIAL NUMBER</u>		<u>CAL DUE DATE</u> (YY MO DD)	<u>USE</u>
Preamplifier system	TDK RF Solutions	PA-02	080010	04-11-05	Radiated Emissions
Preamplifier	Sonoma	310N/11909A	185831	04-11-05	Radiated Emissions
EMC Analyzer	Agilent	E7405A	US40240226	04-07-31	Radiated Emissions
Horn Antenna	TDK	HRN-0118	030101	04-07-18	Radiated Emissions
Horn Antenna	TDK	HRN-0118	030201	03-12-11	Radiated Emissions
Hybrid Log Antenna	TDK	HLP-3003C	017301	03-12-11	Radiated Emissions
Dipole Antenna	Schwarzbeck	UHAP	1018	03-11-30	Radiated Emissions
Dipole Antenna	Schwarzbeck	UHAP	974	04-09-25	Radiated Emissions
Synthesized Sweeper	Agilent	83630B	3844A00927	04-04-30	Radiated Emissions
Spectrum Analyzer	HP	8563E	3745A08112	04-07-31	Conducted Emissions
DC Power Supply	HP	6632B	US37472178	04-08-01	Conducted Emissions
Temperature Probe	Hart Scientific	61161-302	21352860	04-09-15	Conducted Emissions
Environmental Chamber	ESPEC Corp.	SH-240S1	91007118	N/R	Frequency Stability
Wireless Communication Test Set	Agilent	8960	US41070110	05-08-13	Conducted/radiated Emissions
Wireless Communication Test Set	Agilent	8960	6B41070272	03-11-26	Conducted/radiated Emissions

APPENDIX 1

CONDUCTED EMISSIONS TEST DATA/PLOTS

Conducted Emission Test Results

This appendix contains measurement data pertaining to conducted spurious emissions, 99% power bandwidth and the channel mask.

Test Setup Diagram

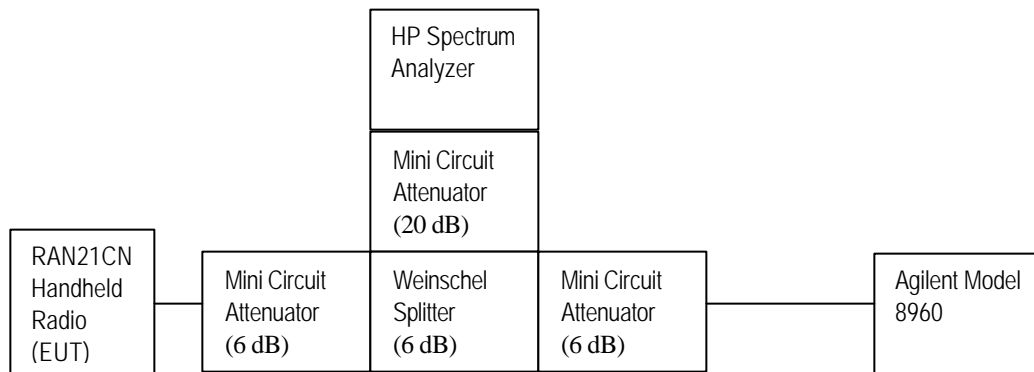

Test Equipment List

Test Instruments	Manufacturer	Model No.	Serial No.	Frequency Range
Spectrum Analyzer	HP	8563E	374A08112	30 Hz – 26.5 GHz
Splitter	Weinschel	1515	ME092	DC – 18 GHz
Attenuator	Mini Circuit	MCL BW-S20W2	--	DC – 18 GHz
Attenuator	Mini Circuit	MCL BW-S6W2	--	DC – 18 GHz
Attenuator	Mini Circuit	MCL BW-S6W2	--	DC – 18 GHz
Wireless Communication Test Set	Agilent	8960	6B41070272	--

Conducted Emission Test Data Cont'd

The conducted spurious emissions – As per 47 CFR 2.202, 47 CFR 2.1057, 47 CFR 24.238, RSS-133, CFR 22 Subpart H and RSS-129 were measured from 10 MHz to 20 GHz. The EUT emissions were in the noise floor.

See figures 1 to 12 for the plots of the conducted spurious emissions.

Test Data for Cellular and PCS selected Frequencies

Cellular Frequency (MHz)	-99% Occupied Bandwidth (MHz)
824.700	1.269
836.520	1.269
848.310	1.288

PCS Frequency (MHz)	99% Occupied Bandwidth (MHz)
1851.200	1.280
1880.000	1.290
1908.750	1.290

Measurement Plots for Cellular and PCS

Refer to the following measurement plots for more detail.

See Figures 1 to 12 for plots of the Spurious Emission results

See Figures 13 to 18 for the plots of the 99% Occupied Bandwidth.

See Figures 19 to 20 for plots of the channel mask results.

The RF power output was at maximum for all the recorded measurements shown below.

Conducted Emission Test Results Cont'd

Figure 15: Occupied Bandwidth, Cellular High Channel

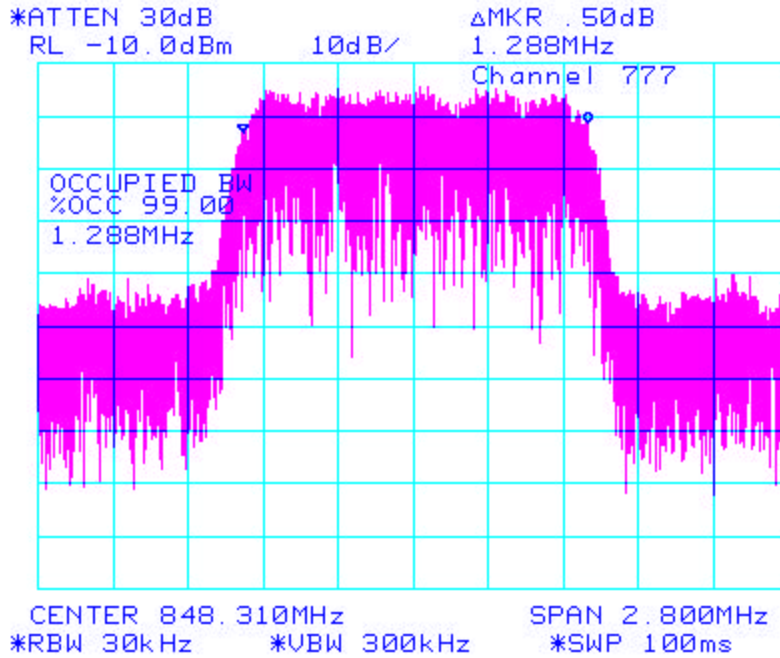
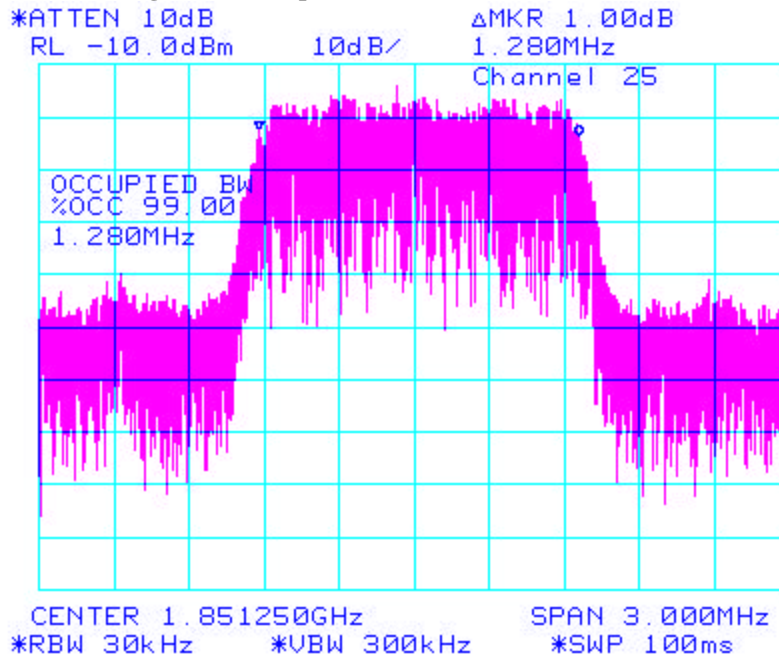
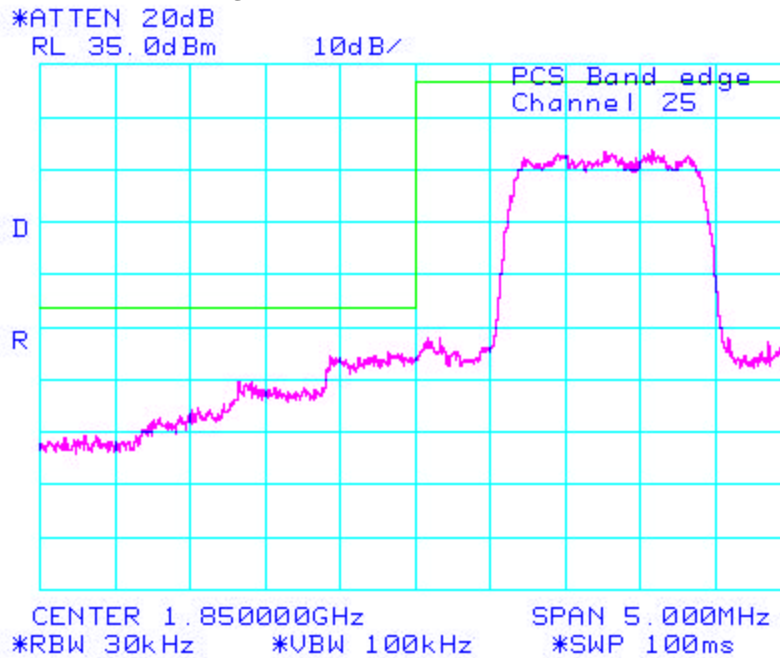
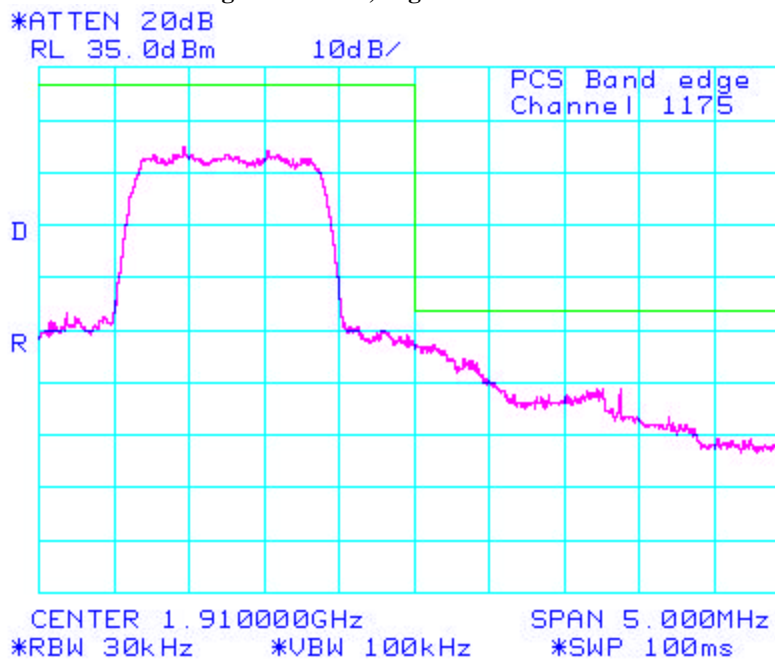

Figure 16: Occupied Bandwidth, PCS Low Channel



Conducted Emission Test Results Cont'd**Figure 19: PCS, Low Channel Mask****Figure 20: PCS, High Channel Mask**

Conducted Emission Test-Setup Photo



APPENDIX 2

CONDUCTED RF OUTPUT POWER TEST DATA

Conducted RF Output Power Test Data

The conducted RF output power was measured using the Agilent Wireless Communication Test Set, model 8960. Low, middle and high channels were measured at maximum radio output power. Peak nominal output power is 24.5 dBm for Cellular and 23.0 dBm for PCS.

Test results

Channel	Frequency (MHz)	Maximum Output Power (dBm)
<u>Cellular</u>		
1013	824.700	24.30
384	836.520	24.60
777	848.310	24.70
<u>PCS</u>		
25	1851.200	23.30
600	1880.000	23.40
1175	1908.750	23.35

APPENDIX 3

FREQUENCY STABILITY TEST DATA

Frequency Stability Test Data

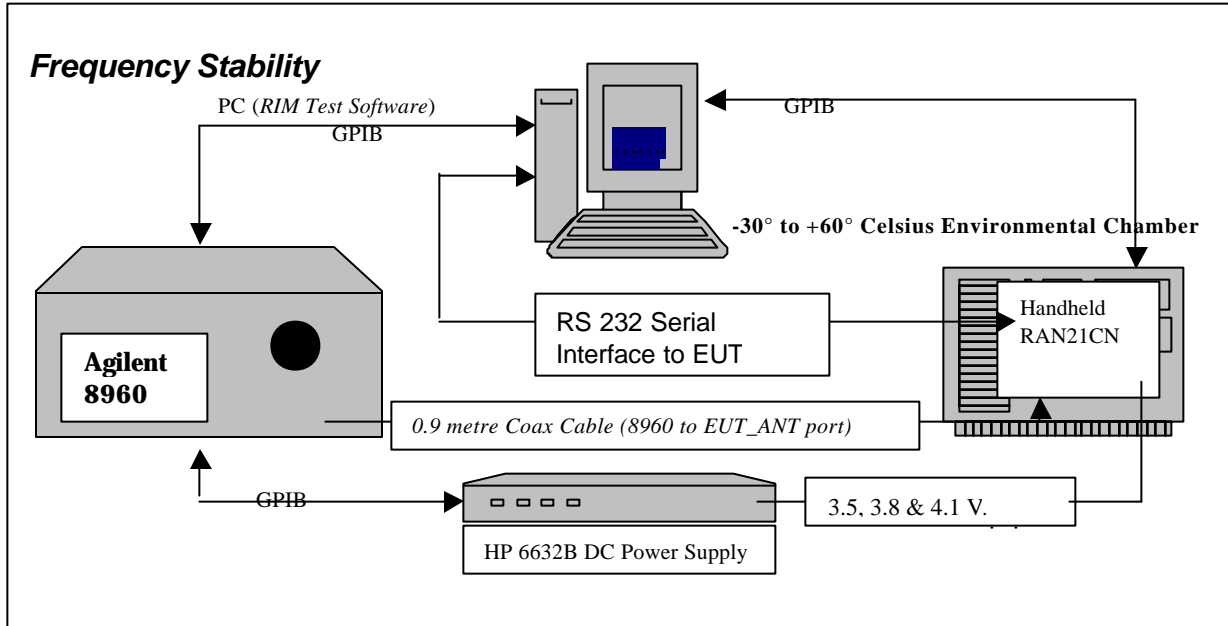

<i>SYSTEM</i>	<i>Model</i>	<i>Serial Number</i>	<i>Calibration Due Date.</i>
Agilent Wireless Communication Test Set	8960	US41070110	13 Aug. 2005
HP System DC Power Supply	6632B	US37472178	01-Aug.-2004
Network Analyzer	HP 8720D	US36140834	05-Aug.-2004
Calibration Kit	HP85033D	3423A02787	28-Sept.-2004
Espec Environmental Chamber	SH240S1	91007118	N/A
Hart Temperature Probe	61161-302	21352860	15-Sept. 2004

CFR 47 Chapter 1 - Federal Communications Commission Rules

Part 2 Required Measurements

2.995 Frequency Stability - Procedures

(a,b) Frequency Stability - Temperature Variation

(d) Frequency Stability - Voltage Variation

24.235 *Frequency Stability.*

The frequency stability shall be sufficient to ensure that the fundamental emission stays within the authorized frequency block.

The RAN21CN handheld, (referred as EUT herein and after) transmitted frequencies are less than 0.1 ppm of the received frequency from the Agilent, Wireless Communication Test Set.

The EUT meets the requirements as stated in CFR 47 chapter 1, Section 24.235, RSS-133, CFR 47 chapter 1, Section 22.917 and RSS-129 Frequency Stability.

Frequency Stability measurement devices were configured as presented in the block diagram recording frequency, power, data, temperatures, and stepped voltages controlled via a GPIB interface linked to the Environmental chamber, a DC power supply, and the Communications Test Set. A 0.9-meter coax cable was calibrated to characterize the insertion loss for the transmitted frequencies between the RF input/output of the Wireless Communication Test Set and the EUT antenna port; located inside the environmental chamber.

Calibration for the Cable Loss was performed in the RF Laboratory on November 06, 2003

Procedure:

Full_ Two port Calibration of 8720D using the 85033D was completed.

The cable assembly from the RF input to the RF output was measured at the following Frequencies:

PCS Frequency (MHz)	Cable loss (dB)	Cellular Frequency (MHz)	Cable loss (dB)
1851.20	1.26	824.70	0.83
1880.00	1.26	836.52	0.83
1908.75	1.26	848.31	0.83

Procedure:

The EUT was placed in the Temperature chamber and connected to Wireless Communication Test Set outside as shown in the figure above. Dry air was pumped inside the temperature chamber to maintain a backpressure during the test. The EUT was kept in the off condition at all times except when the measurements were to be made.

The chamber was switched on and the temperature was set to -30°C.

After the chamber stabilized at -30°C there was a soak period of one hour to alleviate moisture in the chamber, the EUT voltage was enabled.

The system software recorded the frequency, power, and associated measurements.

A Computer system controlled the automated software. This application was given the command of activating all machines intrinsic to the temperature and voltage tests controlling the Wireless Communication Test Set via the GPIB Bus. The Environmental Chamber was instructed through an RS-232 serial line. The EUT dialogue was passed through a serial connection.

The EUT repetitively transmitted 100 bursts for each set of programmed parameters recording temperature, voltage settings, and systematically selected frequencies. The power supply was cycled from minimum voltage 3.5 volts, to 3.8 volts to 4.1 volts nominal voltage.

The frequency error was measured at a maximum output power and recorded by the automated system test software.

The EUT frequency was measured at 3.5 volts, 3.8 volts and 4.1 volts. The transmit frequency was varied in 3 steps consisting of 824.70, 836.52, and 848.31 MHz for the cellular band and 1851.20, 1880.00 and 1908.75 MHz for the PCS band. This frequency was recorded in MHz and deviation from nominal, in Parts Per Million.

After the initial one-hour soak at the beginning of the start of the measurement tests, a period of thirty minutes soak was initialized between each ascending temperature step, before proceeding to the next measurement test cycle.

PROCEDURE:

The test system software for commencing the Frequency Stability Tests carried through the following cycle.

1. Switch on the HP 6632B power supply; Wireless Communication Test Set, and Environmental Chamber.
2. Start test program
3. Set the Temperature to -30 degrees Celsius and maintain a period of one- hour soak time, with the EUT supply voltage disabled.
4. Set power supply voltage to 3.5 Volts.
5. Set up Wireless Communication Test Set.
6. Command the Wireless Communication Test Set to switch to the low channel.
7. Enable the voltage to the EUT, and connect a link to the Wireless Communication Test Set.
8. EUT is commanded to Transmit 100 Bursts.
9. Software logs the following data from the Wireless Communication Test Set, power supply and temperature chamber: Traffic Channel Number, Traffic Channel Frequency, Power Level, Chamber Temperature, Supply Voltage, Power, Frequency Error.
10. The Wireless Communication Test Set commands the EUT to change frequency to the middle channel and high channel and repeats steps 7 to 9.
11. Repeat steps 5 to 10 changing the supply voltage to 3.8 Volts
12. Increase temperature by 10 degrees Celsius and soak for 1/2 hour.
13. Repeat steps 4 - 12 for temperatures -30 degrees to 60 degrees Celsius.
14. Repeat steps 5 to 10 changing the supply voltage to 4.1 Volts

Procedure 5 to 10 was repeated at room temperature (20 degrees Celsius) with the power supply voltage set to 3.5, 3.8 and 4.1 Volts.

Cellular Channel results: channels 1013, 384 and 777 @ 20°C maximum transmitted power

Traffic Channel Number	Cellular Frequency (MHz)	Voltage (Volts)	Temperature (Celsius)	Frequency Error (Hz)	PPM
1013	824.700	3.5	20	-0.18	-0.0002
384	836.520	3.5	20	0.16	0.0002
777	848.310	3.5	20	-2.90	-0.0034

Traffic Channel Number	cellular Frequency (MHz)	Voltage (Volts)	Temperature (Celsius)	Frequency Error (Hz)	PPM
1013	824.700	3.8	20	-1.89	-0.0023
384	836.520	3.8	20	-2.57	-0.0031
777	848.310	3.8	20	-1.33	-0.0016

Traffic Channel Number	Cellular Frequency (MHz)	Voltage (Volts)	Temperature (Celsius)	Frequency Error (Hz)	PPM
1013	824.700	4.1	20	-0.81	-0.0010
384	836.520	4.1	20	-0.87	-0.0010
777	848.310	4.1	20	-2.09	-0.0025

Cellular Results: channel 1013 @ maximum transmitted power

Traffic Channel Number	Frequency (MHz)	Voltage (Volts)	Temperature (Celsius)	Frequency Error (Hz)	PPM
1013	824.700	3.5	-30	-2.88	-0.0035
1013	824.700	3.5	-20	-1.74	-0.0021
1013	824.700	3.5	-10	-0.83	-0.0010
1013	824.700	3.5	0	-1.18	-0.0014
1013	824.700	3.5	10	-1.66	-0.0020
1013	824.700	3.5	20	-0.18	-0.0002
1013	824.700	3.5	30	-1.25	-0.0015
1013	824.700	3.5	40	-1.51	-0.0018
1013	824.700	3.5	50	-1.47	-0.0018
1013	824.700	3.5	60	-3.01	-0.0036

Traffic Channel Number	Frequency (MHz)	Voltage (Volts)	Temperature (Celsius)	Frequency Error (Hz)	PPM
1013	824.700	3.8	-30	-1.38	-0.0017
1013	824.700	3.8	-20	-0.37	-0.0004
1013	824.700	3.8	-10	-0.14	-0.0002
1013	824.700	3.8	0	-0.52	-0.0006
1013	824.700	3.8	10	-1.74	-0.0021
1013	824.700	3.8	20	-1.89	-0.0023
1013	824.700	3.8	30	-0.31	-0.0004
1013	824.700	3.8	40	-0.40	-0.0005
1013	824.700	3.8	50	-1.36	-0.0016
1013	824.700	3.8	60	-2.24	-0.0027

Traffic Channel Number	Frequency (MHz)	Voltage (Volts)	Temperature (Celsius)	Frequency Error (Hz)	PPM
1013	824.700	4.1	-30	-1.21	-0.0015
1013	824.700	4.1	-20	-1.81	-0.0022
1013	824.700	4.1	-10	-0.16	-0.0002
1013	824.700	4.1	0	-3.07	-0.0037
1013	824.700	4.1	10	-2.39	-0.0029
1013	824.700	4.1	20	-0.81	-0.0010
1013	824.700	4.1	30	-0.83	-0.0010
1013	824.700	4.1	40	-1.65	-0.0020
1013	824.700	4.1	50	-1.88	-0.0023
1013	824.700	4.1	60	-2.36	-0.0029

Cellular Results: channel 384 @ maximum transmitted power

Traffic Channel Number	Frequency (MHz)	Voltage (Volts)	Temperature (Celsius)	Frequency Error (Hz)	PPM
384	836.520	3.5	-30	-0.96	-0.0012
384	836.520	3.5	-20	0.05	0.0001
384	836.520	3.5	-10	0.42	0.0005
384	836.520	3.5	0	-1.53	-0.0018
384	836.520	3.5	10	-3.48	-0.0042
384	836.520	3.5	20	0.16	0.0002
384	836.520	3.5	30	-3.97	-0.0047
384	836.520	3.5	40	-2.11	-0.0025
384	836.520	3.5	50	-0.62	-0.0007
384	836.520	3.5	60	0.75	0.0009

Traffic Channel Number	Frequency (MHz)	Voltage (Volts)	Temperature (Celsius)	Frequency Error (Hz)	PPM
384	836.520	3.8	-30	0.31	0.0004
384	836.520	3.8	-20	0.63	0.0008
384	836.520	3.8	-10	-1.67	-0.0020
384	836.520	3.8	0	-2.24	-0.0027
384	836.520	3.8	10	1.21	0.0014
384	836.520	3.8	20	-2.57	-0.0031
384	836.520	3.8	30	-1.71	-0.0020
384	836.520	3.8	40	-1.40	-0.0017
384	836.520	3.8	50	-1.02	-0.0012
384	836.520	3.8	60	-1.09	-0.0013

Traffic Channel Number	Frequency (MHz)	Voltage (Volts)	Temperature (Celsius)	Frequency Error (Hz)	PPM
384	836.520	4.1	-30	0.00	0.0000
384	836.520	4.1	-20	-0.17	-0.0002
384	836.520	4.1	-10	0.69	0.0008
384	836.520	4.1	0	0.24	0.0003
384	836.520	4.1	10	1.35	0.0016
384	836.520	4.1	20	-0.87	-0.0010
384	836.520	4.1	30	0.68	0.0008
384	836.520	4.1	40	0.74	0.0009
384	836.520	4.1	50	-2.59	-0.0031
384	836.520	4.1	60	-1.33	-0.0016

Cellular Results: channel 777 @ maximum transmitted power

Traffic Channel Number	Frequency (MHz)	Voltage (Volts)	Temperature (Celsius)	Frequency Error (Hz)	PPM
777	848.310	3.5	-30	0.09	0.0001
777	848.310	3.5	-20	-0.20	-0.0002
777	848.310	3.5	-10	-0.74	-0.0009
777	848.310	3.5	0	-0.59	-0.0007
777	848.310	3.5	10	1.26	0.0015
777	848.310	3.5	20	-2.90	-0.0034
777	848.310	3.5	30	-1.01	-0.0012
777	848.310	3.5	40	-1.52	-0.0018
777	848.310	3.5	50	0.96	0.0011
777	848.310	3.5	60	-3.72	-0.0044

Traffic Channel Number	Frequency (MHz)	Voltage (Volts)	Temperature (Celsius)	Frequency Error (Hz)	PPM
777	848.310	3.8	-30	0.17	0.0002
777	848.310	3.8	-20	-1.80	-0.0021
777	848.310	3.8	-10	-1.97	-0.0023
777	848.310	3.8	0	-3.11	-0.0037
777	848.310	3.8	10	-0.49	-0.0006
777	848.310	3.8	20	-1.33	-0.0016
777	848.310	3.8	30	1.33	0.0016
777	848.310	3.8	40	-1.81	-0.0021
777	848.310	3.8	50	0.60	0.0007
777	848.310	3.8	60	-1.83	-0.0022

Traffic Channel Number	Frequency (MHz)	Voltage (Volts)	Temperature (Celsius)	Frequency Error (Hz)	PPM
777	848.310	4.1	-30	-2.41	-0.0028
777	848.310	4.1	-20	-1.14	-0.0013
777	848.310	4.1	-10	-0.14	-0.0002
777	848.310	4.1	0	-2.36	-0.0028
777	848.310	4.1	10	-0.70	-0.0008
777	848.310	4.1	20	-2.09	-0.0025
777	848.310	4.1	30	-3.85	-0.0045
777	848.310	4.1	40	-3.92	-0.0046
777	848.310	4.1	50	1.96	0.0023
777	848.310	4.1	60	-3.12	-0.0037

PCS Channel results: channels 512, 661, & 810 @ 20°C maximum transmitted power

Traffic Channel Number	PCS Frequency (MHz)	Voltage (Volts)	Temperature (Celsius)	Frequency Error (Hz)	PPM
25	1851.200	3.5	20	-2.69	-0.0015
600	1880.000	3.5	20	1.77	0.0009
1175	1908.750	3.5	20	-1.23	-0.0006

Traffic Channel Number	PCS Frequency (MHz)	Voltage (Volts)	Temperature (Celsius)	Frequency Error (Hz)	PPM
25	1851.200	3.8	20	0.14	0.0001
600	1880.000	3.8	20	-2.78	-0.0015
1175	1908.750	3.8	20	4.79	0.0025

Traffic Channel Number	PCS Frequency (MHz)	Voltage (Volts)	Temperature (Celsius)	Frequency Error (Hz)	PPM
25	1851.200	4.1	20	-4.00	-0.0022
600	1880.000	4.1	20	-6.50	-0.0035
1175	1908.750	4.1	20	-6.68	-0.0035

PCS Results: channel 25 @ maximum transmitted power

Traffic Channel Number	Frequency (MHz)	Voltage (Volts)	Temperature (Celsius)	Frequency Error (Hz)	PPM
25	1851.20	3.5	-30	1.21	0.0007
25	1851.20	3.5	-20	-0.55	-0.0003
25	1851.20	3.5	-10	-3.41	-0.0018
25	1851.20	3.5	0	-0.35	-0.0002
25	1851.20	3.5	10	-9.74	-0.0053
25	1851.20	3.5	20	-2.69	-0.0015
25	1851.20	3.5	30	-0.32	-0.0002
25	1851.20	3.5	40	2.92	0.0016
25	1851.20	3.5	50	-4.97	-0.0027
25	1851.20	3.5	60	-2.80	-0.0015

Traffic Channel Number	Frequency (MHz)	Voltage (Volts)	Temperature (Celsius)	Frequency Error (Hz)	PPM
25	1851.20	3.8	-30	0.79	0.0004
25	1851.20	3.8	-20	-0.74	-0.0004
25	1851.20	3.8	-10	0.81	0.0004
25	1851.20	3.8	0	0.10	0.0001
25	1851.20	3.8	10	-2.32	-0.0013
25	1851.20	3.8	20	0.14	0.0001
25	1851.20	3.8	30	-0.94	-0.0005
25	1851.20	3.8	40	-4.85	-0.0026
25	1851.20	3.8	50	-3.62	-0.0020
25	1851.20	3.8	60	4.59	0.0025

Traffic Channel Number	Frequency (MHz)	Voltage (Volts)	Temperature (Celsius)	Frequency Error (Hz)	PPM
25	1851.20	4.1	-30	-3.86	-0.0021
25	1851.20	4.1	-20	-0.67	-0.0004
25	1851.20	4.1	-10	-2.60	-0.0014
25	1851.20	4.1	0	-4.55	-0.0025
25	1851.20	4.1	10	-4.66	-0.0025
25	1851.20	4.1	20	-4.00	-0.0022
25	1851.20	4.1	30	-7.97	-0.0043
25	1851.20	4.1	40	-3.36	-0.0018
25	1851.20	4.1	50	-1.37	-0.0007
25	1851.20	4.1	60	-1.06	-0.0006

PCS Results: channel 600 @ maximum transmitted power

Traffic Channel Number	Frequency (MHz)	Voltage (Volts)	Temperature (Celsius)	Frequency Error (Hz)	PPM
600	1880.00	3.5	-30	-3.42	-0.0018
600	1880.00	3.5	-20	1.36	0.0007
600	1880.00	3.5	-10	1.11	0.0006
600	1880.00	3.5	0	2.20	0.0012
600	1880.00	3.5	10	-1.98	-0.0011
600	1880.00	3.5	20	1.77	0.0009
600	1880.00	3.5	30	0.25	0.0001
600	1880.00	3.5	40	2.36	0.0013
600	1880.00	3.5	50	-3.00	-0.0016
600	1880.00	3.5	60	-1.62	-0.0009

Traffic Channel Number	Frequency (MHz)	Voltage (Volts)	Temperature (Celsius)	Frequency Error (Hz)	PPM
600	1880.00	3.8	-30	-3.34	-0.0018
600	1880.00	3.8	-20	-5.49	-0.0029
600	1880.00	3.8	-10	-2.39	-0.0013
600	1880.00	3.8	0	-3.71	-0.0020
600	1880.00	3.8	10	2.07	0.0011
600	1880.00	3.8	20	-2.78	-0.0015
600	1880.00	3.8	30	-4.29	-0.0023
600	1880.00	3.8	40	4.37	0.0023
600	1880.00	3.8	50	0.38	0.0002
600	1880.00	3.8	60	-2.66	-0.0014

Traffic Channel Number	Frequency (MHz)	Voltage (Volts)	Temperature (Celsius)	Frequency Error (Hz)	PPM
600	1880.00	4.1	-30	-1.69	-0.0009
600	1880.00	4.1	-20	-2.76	-0.0015
600	1880.00	4.1	-10	-2.83	-0.0015
600	1880.00	4.1	0	-1.01	-0.0005
600	1880.00	4.1	10	0.22	0.0001
600	1880.00	4.1	20	-6.50	-0.0035
600	1880.00	4.1	30	2.09	0.0011
600	1880.00	4.1	40	-1.20	-0.0006
600	1880.00	4.1	50	2.05	0.0011
600	1880.00	4.1	60	-0.24	-0.0001

PCS Results: channel 1175 @ maximum transmitted power

Traffic Channel Number	Frequency (MHz)	Voltage (Volts)	Temperature (Celsius)	Frequency Error (Hz)	PPM
1175	1908.75	3.5	-30	-3.55	-0.0019
1175	1908.75	3.5	-20	-3.23	-0.0017
1175	1908.75	3.5	-10	-8.20	-0.0043
1175	1908.75	3.5	0	1.49	0.0008
1175	1908.75	3.5	10	-2.91	-0.0015
1175	1908.75	3.5	20	-1.23	-0.0006
1175	1908.75	3.5	30	-5.82	-0.0030
1175	1908.75	3.5	40	-4.28	-0.0022
1175	1908.75	3.5	50	-2.61	-0.0014
1175	1908.75	3.5	60	-0.41	-0.0002

Traffic Channel Number	Frequency (MHz)	Voltage (Volts)	Temperature (Celsius)	Frequency Error (Hz)	PPM
1175	1908.75	3.8	-30	-1.13	-0.0006
1175	1908.75	3.8	-20	2.50	0.0013
1175	1908.75	3.8	-10	0.12	0.0001
1175	1908.75	3.8	0	-0.63	-0.0003
1175	1908.75	3.8	10	-4.33	-0.0023
1175	1908.75	3.8	20	4.79	0.0025
1175	1908.75	3.8	30	-0.41	-0.0002
1175	1908.75	3.8	40	2.29	0.0012
1175	1908.75	3.8	50	-2.21	-0.0012
1175	1908.75	3.8	60	-4.63	-0.0024

Traffic Channel Number	Frequency (MHz)	Voltage (Volts)	Temperature (Celsius)	Frequency Error (Hz)	PPM
1175	1908.75	4.1	-30	-0.02	0.0000
1175	1908.75	4.1	-20	-4.79	-0.0025
1175	1908.75	4.1	-10	-3.00	-0.0016
1175	1908.75	4.1	0	-3.36	-0.0018
1175	1908.75	4.1	10	-4.65	-0.0024
1175	1908.75	4.1	20	-6.68	-0.0035
1175	1908.75	4.1	30	-0.26	-0.0001
1175	1908.75	4.1	40	0.66	0.0003
1175	1908.75	4.1	50	-3.69	-0.0019
1175	1908.75	4.1	60	-0.54	-0.0003

APPENDIX 4

RADIATED EMISSIONS TEST DATA

Radiated Emissions Test Data Results

Test Distance was 3.0 metres.

Cellular Band

November 13, 2003

EUT				Rx Antenna		Spectrum Analyzer		Substitution Method				
Type	Ch	Frequency (MHz)	Band	Type	Pol.	Reading (dBuV)	Max (V,H) (dBuV)	Reading (dBm)	Tracking Generator Corrected Reading (relative to dipole) (dBm)	Pol. Tx-Rx	Limit (dBm)	Diff to Limit (dB)
Cellular Band (ERP)												
Handheld standalone, upright position												
F0	1013	824.700	800	Dipole	V	80.1	80.1	5.6	21.55	V-V	27.78	-6.23
F0	1013	824.700	800	Dipole	H	72.6		3.8		H-H		
F0	417	837.490	800	Dipole	V	79.8	79.8	6.8	22.75	V-V	27.78	-5.03
F0	417	837.940	800	Dipole	H	73.4		4.1		H-H		
F0	777	848.320	800	Dipole	V	79.9	79.9	5.6	21.55	V-V	27.78	-6.23
F0	777	848.320	800	Dipole	H	71.6		4.3		H-H		
Handheld standalone, on its side												
F0	1013	824.700	800	Dipole	V	72.4	81.3	6.8	22.75	V-V	27.78	-5.03
F0	1013	824.700	800	Dipole	H	81.3		5.0		H-H		
F0	417	837.490	800	Dipole	V	73.3	82.8	9.8	25.75	V-V	27.78	-2.03
F0	417	837.940	800	Dipole	H	82.8		7.2		H-H		
F0	777	848.320	800	Dipole	V	73.2	82.2	9.0	24.95	V-V	27.78	-2.83
F0	777	848.320	800	Dipole	H	82.2		6.6		H-H		
Handheld standalone, on its back												
F0	1013	824.700	800	Dipole	V	70.6	80.2	5.7	21.65	V-V	27.78	-6.13
F0	1013	824.700	800	Dipole	H	80.2		3.9		H-H		
F0	417	837.490	800	Dipole	V	72.0	81.4	8.4	24.35	V-V	27.78	-3.43
F0	417	837.940	800	Dipole	H	81.4		5.7		H-H		
F0	777	848.320	800	Dipole	V	73.6	81.7	8.5	24.45	V-V	27.78	-3.33
F0	777	848.320	800	Dipole	H	81.7		6.1		H-H		

Radiated Emissions Test Data Results Cont'd

Test Distance was 3.0 metres.

Cellular Band

November 13, 2003

EUT				Rx Antenna		Spectrum Analyzer			Substitution Method				
Type	Ch	Frequency (MHz)	Band	Type	Pol.	Reading (dBuV)	Corrected Reading (dBuV)	Max (V,H) (dBuV)	Tracking Generator		Pol.	Limit (dBm)	Diff to Limit (dB)
									Reading (dBm)	Corrected Reading (relative to dipole) (dBm)	Tx-Rx		
Cellular Band (Harmonics)													
Handheld standalone, upright position													
Low Channel – 824.70 MHz													
2 nd	1013	1649.40	800	Horn	V	NF	NF				V-V	-13	
2 nd	1013	1649.40	800	Horn	H	NF					H-H		
The harmonics were investigated up to the 10 th harmonic. The harmonic emissions were in the noise floor (NF)													
Middle Channel – 837.47 MHz													
2 nd	417	1674.98	800	Horn	V	NF	NF				V-V	-13	
2 nd	417	1674.98	800	Horn	H	NF					H-H		
The harmonics were investigated up to the 10 th harmonic. The harmonic emissions were in the NF.													
High Channel – 848.32 MHz													
2 nd	777	1696.64	800	Horn	V	NF	NF				V-V	-13	
2 nd	777	1696.64	800	Horn	H	NF					H-H		
The harmonics were investigated up to the 10 th harmonic. The harmonic emissions were in the NF.													

Radiated Emissions Test Results Cont'd

Test Distance was 3.0 metres.

Cellular Band

November 13, 2003

The measurements were performed with the handheld in standalone upright position.

EUT				Rx Antenna		Spectrum Analyzer			Substitution Method				
Type	Ch	Frequency (MHz)	Band	Type	Pol.	Reading (dBuV)	Corrected Reading (dBuV)	Max (V,H) (dBuV)	Reading (dBm)	Corrected Reading (relative to dipole) (dBm)	Pol. Tx-Rx	Limit (dBm)	Diff to Limit (dB)
Cellular BAND (Local Oscillator)													
RF Local Oscillator (LO)													
Low Channel													
F0	1013	1053.30	800	Horn	V	NF	NF				V-V	-13	
F0	1013	1053.30	800	Horn	H	NF					H-H		
Middle Channel													
FO	417	1066.10	800	Horn	V	NF	NF				V-V	-13	
FO	417	1066.10	800	Horn	H	NF					H-H		
High Channel													
F0	777	1076.90	800	Horn	V	NF	NF				V-V	-13	
F0	777	1076.90	800	Horn	H	NF					H-H		

Radiated Emissions Test Data Results Cont'd

Test Distance was 3.0 metres.

PCS Band

November 18, 2003

								Substitution Method				
EUT				Receive Antenna		Spectrum Analyzer		Tracking Generator				
Type	Ch	Frequency (MHz)	Band	Type	Pol.	Reading (dBuV)	Max (V,H) dBuV	Reading (dBm)	Corrected Reading (relative to Isotropic Radiator) (dBm)	Pol. Tx-Rx	Limit (dBm)	Diff to Limit (dB)
PCS BAND (EIRP)												
Handheld standalone, upright position												
F0	25	1851.25	1900	Horn	V	92.0	92.0	-8.0	24.09	V-V	33	-8.91
F0	25	1851.25	1900	Horn	H	78.5		-6.8		H-H		
F0	600	1880.00	1900	Horn	V	91.1	91.1	-7.6	24.79	V-V	33	-8.21
F0	600	1880.00	1900	Horn	H	76.1		-6.1		H-H		
F0	1175	1908.75	1900	Horn	V	88.2	88.2	-10.4	21.79	V-V	33	-11.21
F0	1175	1908.75	1900	Horn	H	74.7		-9.1		H-H		
Handheld standalone, on its side												
F0	25	1851.25	1900	Horn	V	78.1	86.6	-13.3	18.89	V-V	33	-14.11
F0	25	1851.25	1900	Horn	H	86.6		-12.0		H-H		
F0	600	1880.00	1900	Horn	V	77.1	86.0	-12.7	19.69	V-V	33	-13.31
F0	600	1880.00	1900	Horn	H	86.0		-11.2		H-H		
F0	1175	1908.75	1900	Horn	V	77.3	85.2	-13.4	18.79	V-V	33	-14.21
F0	1175	1908.75	1900	Horn	H	85.2		-12.1		H-H		
Handheld standalone, on its back												
F0	25	1851.25	25	Horn	V	81.6	91.3	-8.7	23.39	V-V	33	-9.61
F0	25	1851.25	25	Horn	H	91.3		-7.5		H-H		
F0	600	1880.00	600	Horn	V	80.5	88.1	-10.5	21.69	V-V	33	-11.31
F0	600	1880.00	600	Horn	H	88.1		-9.2		H-H		
F0	1175	1908.75	1175	Horn	V	78.6	88.1	-10.5	21.69	V-V	33	-11.31
F0	1175	1908.75	1175	Horn	H	88.1		-9.2		H-H		

Radiated Emissions Test Data Results Cont'd

Test Distance was 3.0 metres.

PCS Band

November 18, 2003

									Substitution Method																																																																																								
EUT				Receive Antenna			Spectrum Analyzer		Tracking Generator																																																																																								
Type	Ch	Frequency (MHz)	Band	Pol.	Type	Pol.	Reading (dBuV)	Max (V,H) (dBuV)	Reading (dBm)	Corrected Reading (relative to dipole) (dBm)	Pol Tx-Rx	Limit (dBm)	Diff to Limit (dB)																																																																																				
<p>PCS BAND (Harmonics) Handheld, upright position</p> <p>Low Channel 1851.25 MHz</p> <table border="1"> <tr> <td>2nd</td> <td>25</td> <td>3702.50</td> <td>1900</td> <td>V</td> <td>Horn</td> <td>V</td> <td>47.9</td> <td>47.9</td> <td>-39.7</td> <td>-36.1</td> <td>V-V</td> <td>-13</td> <td>-23.1</td> </tr> <tr> <td>2nd</td> <td>25</td> <td>3702.50</td> <td>1900</td> <td>V</td> <td>Horn</td> <td>H</td> <td>47.8</td> <td></td> <td>-39.7</td> <td></td> <td>H-H</td> <td></td> <td></td> </tr> </table> <p>The harmonics were investigated up to the 10th harmonic. Emissions above the 2nd harmonic were in the NF</p> <p>Middle Channel 1880.00 MHz</p> <table border="1"> <tr> <td>2nd</td> <td>600</td> <td>3760.00</td> <td>1900</td> <td>V</td> <td>Horn</td> <td>V</td> <td>46.4</td> <td>49.0</td> <td>-36.8</td> <td>-33.2</td> <td>V-V</td> <td>-13</td> <td>-20.2</td> </tr> <tr> <td>2nd</td> <td>600</td> <td>3760.00</td> <td>1900</td> <td>V</td> <td>Horn</td> <td>H</td> <td>49.0</td> <td></td> <td>-36.9</td> <td></td> <td>H-H</td> <td></td> <td></td> </tr> </table> <p>The harmonics were investigated up to the 10th harmonic. Emissions above the 2nd harmonic were in the NF</p> <p>High Channel 1908.75 MHz</p> <table border="1"> <tr> <td>2nd</td> <td>1175</td> <td>3817.50</td> <td>1900</td> <td>V</td> <td>Horn</td> <td>V</td> <td>47.4</td> <td>47.4</td> <td>-40.2</td> <td>-36.6</td> <td>V-V</td> <td>-13</td> <td>-23.6</td> </tr> <tr> <td>2nd</td> <td>1175</td> <td>3817.50</td> <td>1900</td> <td>V</td> <td>Horn</td> <td>H</td> <td>45.4</td> <td></td> <td>-40.6</td> <td></td> <td>H-H</td> <td></td> <td></td> </tr> </table> <p>The harmonics were investigated up to the 10th harmonic. Emissions above the 2nd harmonic were in the NF</p>														2nd	25	3702.50	1900	V	Horn	V	47.9	47.9	-39.7	-36.1	V-V	-13	-23.1	2nd	25	3702.50	1900	V	Horn	H	47.8		-39.7		H-H			2nd	600	3760.00	1900	V	Horn	V	46.4	49.0	-36.8	-33.2	V-V	-13	-20.2	2nd	600	3760.00	1900	V	Horn	H	49.0		-36.9		H-H			2nd	1175	3817.50	1900	V	Horn	V	47.4	47.4	-40.2	-36.6	V-V	-13	-23.6	2nd	1175	3817.50	1900	V	Horn	H	45.4		-40.6		H-H		
2nd	25	3702.50	1900	V	Horn	V	47.9	47.9	-39.7	-36.1	V-V	-13	-23.1																																																																																				
2nd	25	3702.50	1900	V	Horn	H	47.8		-39.7		H-H																																																																																						
2nd	600	3760.00	1900	V	Horn	V	46.4	49.0	-36.8	-33.2	V-V	-13	-20.2																																																																																				
2nd	600	3760.00	1900	V	Horn	H	49.0		-36.9		H-H																																																																																						
2nd	1175	3817.50	1900	V	Horn	V	47.4	47.4	-40.2	-36.6	V-V	-13	-23.6																																																																																				
2nd	1175	3817.50	1900	V	Horn	H	45.4		-40.6		H-H																																																																																						

Radiated Emissions Test Results Cont'd

Test Distance was 3.0 metres.

PCS Band

November 18, 2003

The measurements were performed with the handheld in standalone upright position.

EUT				Rx Antenna		Spectrum Analyzer			Substitution Method				
Type	Ch	Frequency (MHz)	Band	Type	Pol.	Reading (dBuV)	Corrected Reading (dBuV)	Max (V,H) (dBuV)	Tracking Generator		Pol.	Limit (dBm)	Diff to Limit (dB)
PCS BAND (Local Oscillator)													
RF Local Oscillator (LO)													
Low Channel													
F0	25	2114.85	1900	Horn	V	NF	NF				V-V	-13	
F0	25	2114.85	1900	Horn	H	NF					H-H		
Middle Channel													
F0	600	2143.60	1900	Horn	V	NF	NF				V-V	-13	
F0	600	2143.60	1900	Horn	H	NF					H-H		
High Channel													
FO	1175	2172.35	1900	Horn	V	NF	NF				V-V	-13	
FO	1175	2172.35	1900	Horn	H	NF					H-H		

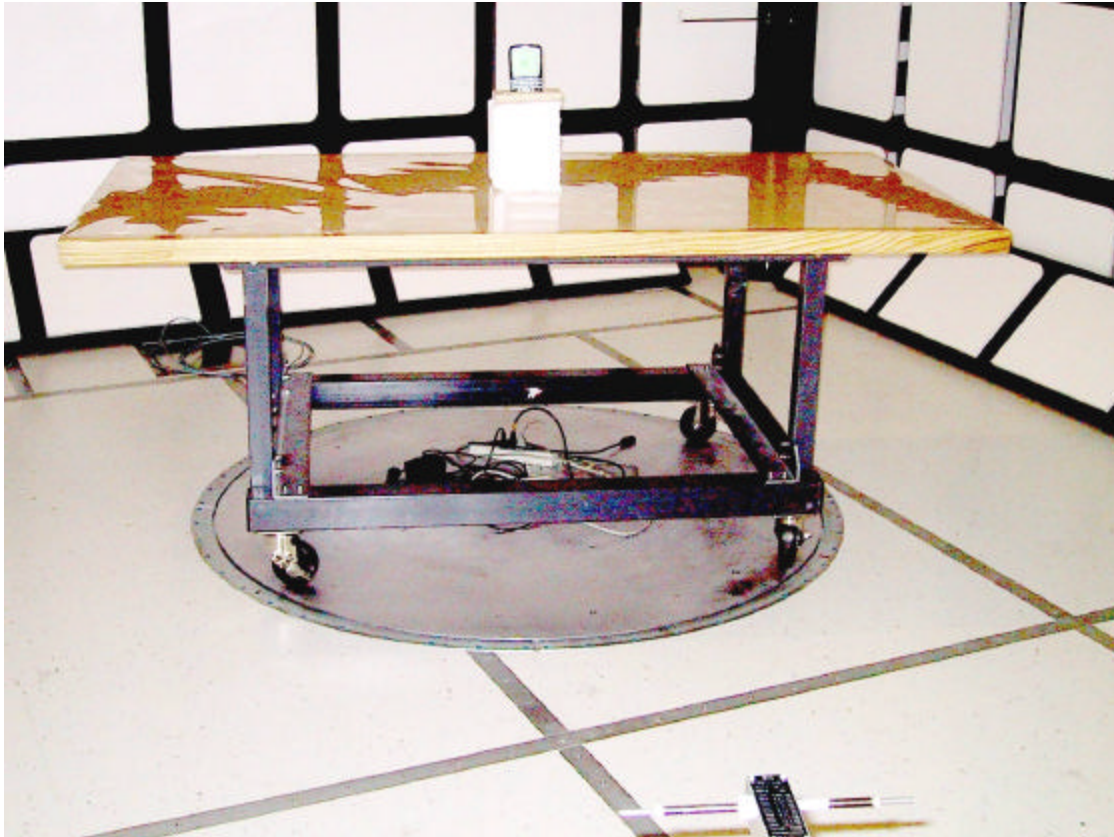
Radiated Emissions Test Photo Cont'd

Radiated Emissions at 3.0 metres