

# ENGINEERING TEST REPORT

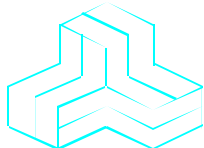

**BlackBerry Wireless Handheld**

**Model No.: R1900G-1-4**

**FCC ID: L6AR1900G-1-4**

*Applicant:* **Research In Motion Limited**  
295 Phillip Street  
Waterloo, Ontario  
Canada, N2L 3W8

*Tested in Accordance With*

**Federal Communications Commission (FCC)  
PERSONAL COMMUNICATIONS SERVICES  
CFR 47, PARTS 2 and 24 (Subpart E)**

**UltraTech's File No.: RIM19-FTX**

This Test report is Issued under the Authority of  
Tri M. Luu, Professional Engineer,  
Vice President of Engineering  
UltraTech Group of Labs

Date: Sep. 14, 2001



Report Prepared by: Tri Luu, P.Eng.

Tested by: Mr. Hung Trinh, RFI/EMI Technician

Issued Date: Sep. 14, 2001

Test Dates: Sep. 14, 2001

*The results in this Test Report apply only to the sample(s) tested, and the sample tested is randomly selected.*

## UltraTech

3000 Bristol Circle, Oakville, Ontario, Canada, L6H 6G4  
Telephone (905) 829-1570 Facsimile (905) 829-8050

Website: [www.ultratech-labs.com](http://www.ultratech-labs.com) Email: [vhk.ultratech@sympatico.ca](mailto:vhk.ultratech@sympatico.ca)

## TABLE OF CONTENTS

<b>EXHIBIT 1. INTRODUCTION.....</b>	<b>1</b>
1.1. SCOPE.....	1
1.2. NORMATIVE REFERENCES.....	1
<b>EXHIBIT 2. PERFORMANCE ASSESSMENT.....</b>	<b>2</b>
2.1. CLIENT INFORMATION.....	2
2.2. EQUIPMENT UNDER TEST (EUT) INFORMATION.....	2
2.3. EUT'S TECHNICAL SPECIFICATIONS.....	3
2.4. LIST OF EUT'S PORTS.....	3
2.5. MODIFICATIONS INCORPORATED IN THE EUT FOR COMPLIANCE PURPOSES.....	4
2.6. ANCILLARY EQUIPMENT.....	4
<b>EXHIBIT 3. EUT OPERATING CONDITIONS AND CONFIGURATIONS DURING TESTS.....</b>	<b>5</b>
3.1. CLIMATE TEST CONDITIONS.....	5
3.2. OPERATIONAL TEST CONDITIONS & ARRANGEMENT FOR TEST SIGNALS.....	5
<b>EXHIBIT 4. SUMMARY OF TEST RESULTS.....</b>	<b>6</b>
4.1. LOCATION OF TESTS.....	6
4.2. APPLICABILITY & SUMMARY OF EMC EMISSION TEST RESULTS.....	6
<b>EXHIBIT 5. MEASUREMENTS, EXAMINATIONS &amp; TEST DATA FOR EMC EMISSIONS.....</b>	<b>7</b>
5.1. TEST PROCEDURES.....	7
5.2. MEASUREMENT UNCERTAINTIES.....	7
5.3. MEASUREMENT EQUIPMENT USED:.....	7
5.4. ESSENTIAL/PRIMARY FUNCTIONS AS DECLARED BY THE MANUFACTURER:.....	7
5.5. EMISSION LIMITS (RADIATED) @ FCC 2.1049, 24.236 & 24.238.....	8
5.5.1. <i>Limits</i> .....	8
5.5.2. <i>Method of Measurements</i> .....	8
5.5.3. <i>Test Equipment List</i> .....	9
5.5.4. <i>Test Arrangement</i> .....	10
5.5.4.1. Test Configuration #1:- The EUT sit on the cradle.....	10
5.5.5. <i>Photographs of Test Setup</i> .....	11
5.5.5.1. Test configurations # 2: Handheld stand-alone.....	14
5.5.6. <i>Test Data</i> .....	18
5.5.6.1. EIRP Measurements of the RF Output.....	18
5.5.6.1.1. Test Configuration #1: Model R1900G-1-4 with Radio S/N: 351, Cradle and Headset.....	18
5.5.6.1.2. Test Configuration # 2: Model R1900G-1-4 with Radio S/N: 351, Handheld stand-alone.....	18
5.5.6.2. Spurious/Harmonic Emissions.....	19
5.5.6.2.1. Test Configuration #1: Model R1900G-1-4 with Radio S/N: 351, Cradle and Headset.....	19
<b>EXHIBIT 6. MEASUREMENT UNCERTAINTY.....</b>	<b>21</b>
6.1. RADIATED EMISSION MEASUREMENT UNCERTAINTY.....	21
<b>EXHIBIT 7. MEASUREMENT METHODS.....</b>	<b>22</b>
7.1. RADIATED POWER MEASUREMENTS (ERP & EIRP) USING SUBSTITUTION METHOD.....	22
7.1.1. <i>Maximizing RF Emission Level (E-Field)</i> .....	22

### ULTRATECH GROUP OF LABS

3000 Bristol Circle, Oakville, Ontario, Canada L6H 6G4  
Tel. #: 905-829-1570, Fax. #: 905-829-8050, Email: [vhk.ultratech@sympatico.ca](mailto:vhk.ultratech@sympatico.ca), Website: <http://www.ultratech-labs.com>

File #: RIM19-FTX  
Sep. 14, 2001

- Assessed by ITI (UK) Competent Body, NVLAP (USA) Accreditation Body & ACA/AUSTEL (Australia), VCCI (Japan)
- Accredited by Industry Canada (Canada) under ACC-LAB (Europe/Canada MRA and APEC/Canada MRA)
- Recognized/Listed by FCC (USA)
- All test results contained in this engineering test report are traceable to National Institute of Standards and Technology (NIST)

---

---

7.1.2. *Measuring the EIRP of Spurious/Harmonic Emissions using Substitution Method* .....23

---

---

**ULTRATECH GROUP OF LABS**

3000 Bristol Circle, Oakville, Ontario, Canada L6H 6G4  
Tel. #: 905-829-1570, Fax. #: 905-829-8050, Email: [vhk.ultratech@sympatico.ca](mailto:vhk.ultratech@sympatico.ca), Website: <http://www.ultratech-labs.com>

**File #: RIM19-FTX**  
**Sep. 14, 2001**

- Assessed by ITI (UK) Competent Body, NVLAP (USA) Accreditation Body & ACA/AUSTEL (Australia), VCCI (Japan)
- Accredited by Industry Canada (Canada) under ACC-LAB (Europe/Canada MRA and APEC/Canada MRA)
- Recognized/Listed by FCC (USA)
- All test results contained in this engineering test report are traceable to National Institute of Standards and Technology (NIST)

## EXHIBIT 1. INTRODUCTION

### 1.1. SCOPE

<b>Reference:</b>	FCC Parts 2 and 24 (Subpart E): 1998
<b>Title</b>	Telecommunication - Code of Federal Regulations, CFR 47, Parts 2 & 24
<b>Purpose of Test:</b>	EIRP Measurements of the fundamental and spurious/harmonic emissions for a PCS radio transmitter operating in the frequency band 1850 - 1910 MHz (Broadband PCS)
<b>Test Procedures</b>	Radiated emissions measurements were conducted in accordance with American National Standards Institute ANSI C63.4 - American National Standard for Methods of Measurement of Radio-Noise Emissions from Low-Voltage Electrical and Electronic Equipment in the Range of 9 kHz to 40 GHz.

### 1.2. NORMATIVE REFERENCES

Publication	Year	Title
FCC CFR Parts 2 and 24	1998	Code of Federal Regulations – Telecommunication
ANSI C63.4	1992	American National Standard for Methods of Measurement of Radio-Noise Emissions from Low-Voltage Electrical and Electronic Equipment in the Range of 9 kHz to 40 GHz
CISPR 22 & EN 55022	1997 1998	Limits and Methods of Measurements of Radio Disturbance Characteristics of Information Technology Equipment
CISPR 16-1		Specification for Radio Disturbance and Immunity measuring apparatus and methods

---

#### ULTRATECH GROUP OF LABS

3000 Bristol Circle, Oakville, Ontario, Canada L6H 6G4  
Tel. #: 905-829-1570, Fax. #: 905-829-8050, Email: [vhk.ultratech@sympatico.ca](mailto:vhk.ultratech@sympatico.ca), Website: <http://www.ultratech-labs.com>

File #: RIM19-FTX  
Sep. 14, 2001

- Assessed by ITI (UK) Competent Body, NVLAP (USA) Accreditation Body & ACA/AUSTEL (Australia), VCCI (Japan)
- Accredited by Industry Canada (Canada) under ACC-LAB (Europe/Canada MRA and APEC/Canada MRA)
- Recognized/Listed by FCC (USA)
- All test results contained in this engineering test report are traceable to National Institute of Standards and Technology (NIST)

## EXHIBIT 2. PERFORMANCE ASSESSMENT

### 2.1. CLIENT INFORMATION

APPLICANT	
<b>Name:</b>	Research In Motion Limited
<b>Address:</b>	295 Phillip Street Waterloo, Ontario Canada, N2L 3W8
<b>Contact Person:</b>	Mr. Masud Attayi Phone #: (519) 888-7465 x2442 Fax #: (519) 888-6906 Email Address: mattayi@rim.net

MANUFACTURER	
<b>Name:</b>	Research In Motion Limited
<b>Address:</b>	295 Phillip Street Waterloo, Ontario Canada, N2L 3W8
<b>Contact Person:</b>	Mr. Masud Attayi Phone #: (519) 888-7465 x2442 Fax #: (519) 888-6906 Email Address: mattayi@rim.net

### 2.2. EQUIPMENT UNDER TEST (EUT) INFORMATION

The following information (with the exception of the Date of Receipt) has been supplied by the applicant.

<b>Brand Name:</b>	BlackBerry
<b>Product Name:</b>	BlackBerry Wireless Handheld
<b>Model Name or Number:</b>	R1900G-1-4
<b>Serial Number:</b>	005SB-351D8
<b>Type of Equipment:</b>	Personal Communications Services
<b>External Power Supply:</b>	AC charging adaptor and synchronization cradle supplied
<b>Transmitting/Receiving Antenna Type:</b>	Integral
<b>Primary User Functions of EUT:</b>	e-mail, personal digital assistant (PDA)

#### ULTRATECH GROUP OF LABS

3000 Bristol Circle, Oakville, Ontario, Canada L6H 6G4  
Tel. #: 905-829-1570, Fax. #: 905-829-8050, Email: [vhk.ultratech@sympatico.ca](mailto:vhk.ultratech@sympatico.ca), Website: <http://www.ultratech-labs.com>

File #: RIM19-FTX  
Sep. 14, 2001

- Assessed by ITI (UK) Competent Body, NVLAP (USA) Accreditation Body & ACA/AUSTEL (Australia), VCCI (Japan)
- Accredited by Industry Canada (Canada) under ACC-LAB (Europe/Canada MRA and APEC/Canada MRA)
- Recognized/Listed by FCC (USA)
- All test results contained in this engineering test report are traceable to National Institute of Standards and Technology (NIST)

### 2.3. EUT'S TECHNICAL SPECIFICATIONS

TRANSMITTER	
Equipment Type:	Portable
Intended Operating Environment:	<ul style="list-style-type: none"> <li>• Residential</li> <li>• Commercial, light industry &amp; heavy industry</li> </ul>
Power Supply Requirement:	Internal rechargeable battery – required accessories supplied for charging
RF Output Power Rating:	1.62 Watts EIRP
Duty Cycle:	PCS network – 1 slot in 8 slot frame – 12.5%
Operating Frequency Range:	1850 - 1910 MHz (Broadband PCS)
RF Output Impedance:	Not applicable – antenna is not removable
Channel Spacing:	200 kHz
Occupied Bandwidth (99%):	250 kHz
Emission Designation:	307KGXW
Digital Oscillator Frequencies:	13 MHz
Radio Oscillator Frequencies:	1048 MHz IF LO, 1719-1779 MHz variable oscillators
Antenna Connector Type:	Integral
Antenna Description:	Manufacturer: RIM Type: Internal modified center fed folded dipole Model: PCB-03092-006 Frequency Range: 1850 - 1990 MHz In/Out Impedance: Not applicable – antenna in not removable

### 2.4. LIST OF EUT'S PORTS

Port Number	EUT's Port Description	Number of Identical Ports	Connector Type	Cable Type (Shielded/Non-shielded)
1	Serial I/O & DC	1	JAE PCB-to-cable connector	None
2	Audio	1	2.5mm audio plug	None

**NOTES:**

- (1) **Ports of the EUT which in normal operation** were connected to ancillary equipment through interconnecting cables via a representative interconnecting cable to simulate the input/output characteristics.
- (2) **Ports which are not connected to cables during normal intended operation** (for factory/technical services uses only)

None.

**ULTRATECH GROUP OF LABS**

3000 Bristol Circle, Oakville, Ontario, Canada L6H 6G4  
 Tel. #: 905-829-1570, Fax. #: 905-829-8050, Email: [vhk.ultratech@sympatico.ca](mailto:vhk.ultratech@sympatico.ca), Website: <http://www.ultratech-labs.com>

File #: RIM19-FTX  
 Sep. 14, 2001

- Assessed by ITI (UK) Competent Body, NVLAP (USA) Accreditation Body & ACA/AUSTEL (Australia), VCCI (Japan)
- Accredited by Industry Canada (Canada) under ACC-LAB (Europe/Canada MRA and APEC/Canada MRA)
- Recognized/Listed by FCC (USA)
- All test results contained in this engineering test report are traceable to National Institute of Standards and Technology (NIST)

## 2.5. MODIFICATIONS INCORPORATED IN THE EUT FOR COMPLIANCE PURPOSES

None

## 2.6. ANCILLARY EQUIPMENT

The EUT was tested while connected to the following representative configuration of ancillary equipment necessary to exercise the ports during tests:

<b>Ancillary Equipment # 1</b>	
Description:	Cradle
Brand name:	BlackBerry
Model Name or Number:	ASY-02556-111
Serial Number:	Pre-production sample
Cable Length & Type:	2m shielded with RS232 termination to plug into computer and DC receptacle
Connected to EUT's Port:	Serial I/O & DC

<b>Ancillary Equipment # 2</b>	
Description:	AC charging adapter
Brand name:	BlackBerry
Model Name or Number:	PWR-02908-003
Serial Number:	Pre-production sample
Cable Length & Type:	2m unshielded with barrel jack
Connected to EUT's Port:	None – it is plugs into receptacle by RS232 connector on cradle cable

<b>Ancillary Equipment # 3</b>	
Description:	Headset
Model Name or Number:	HDW-03458-001
Serial Number:	N/A
Cable Length & Type:	1.2m
Connected to EUT's Port:	Audio

---

### ULTRATECH GROUP OF LABS

3000 Bristol Circle, Oakville, Ontario, Canada L6H 6G4  
Tel. #: 905-829-1570, Fax. #: 905-829-8050, Email: [vhk.ultratech@sympatico.ca](mailto:vhk.ultratech@sympatico.ca), Website: <http://www.ultratech-labs.com>

File #: RIM19-FTX  
Sep. 14, 2001

- Assessed by ITI (UK) Competent Body, NVLAP (USA) Accreditation Body & ACA/AUSTEL (Australia), VCCI (Japan)
- Accredited by Industry Canada (Canada) under ACC-LAB (Europe/Canada MRA and APEC/Canada MRA)
- Recognized/Listed by FCC (USA)
- All test results contained in this engineering test report are traceable to National Institute of Standards and Technology (NIST)

## EXHIBIT 3. EUT OPERATING CONDITIONS AND CONFIGURATIONS DURING TESTS

### 3.1. CLIMATE TEST CONDITIONS

The climate conditions of the test environment are as follows:

Temperature:	21°C
Humidity:	51%
Pressure:	102 kPa
Power input source:	Internal rechargeable battery

### 3.2. OPERATIONAL TEST CONDITIONS & ARRANGEMENT FOR TEST SIGNALS

<b>Operating Modes:</b>	The transmitter was operated in a continuous transmission mode with the carrier modulated as specified in the Test Data.
<b>Special Test Software:</b>	N/A
<b>Special Hardware Used:</b>	R&S CMU 200

<b>Transmitter Test Signals</b>	
<b>Frequency Band(s):</b>	Near lowest, near middle & near highest frequencies each frequency bands that the transmitter covers:
▪ 1850 – 1910 MHz	▪ 1850.2 MHz, 1880.0 MHz and 1909.8 MHz
<b>Transmitter Wanted Output Test Signals:</b>	
▪ RF Power Output (measured maximum output power):	▪ 1.62 Watts (e.i.r.p.)
▪ Normal Test Modulation	▪ GXW
▪ Modulating signal source:	▪ Internal

#### ULTRATECH GROUP OF LABS

3000 Bristol Circle, Oakville, Ontario, Canada L6H 6G4  
Tel. #: 905-829-1570, Fax. #: 905-829-8050, Email: [vhk.ultratech@sympatico.ca](mailto:vhk.ultratech@sympatico.ca), Website: <http://www.ultratech-labs.com>

File #: RIM19-FTX  
Sep. 14, 2001

- Assessed by ITI (UK) Competent Body, NVLAP (USA) Accreditation Body & ACA/AUSTEL (Australia), VCCI (Japan)
- Accredited by Industry Canada (Canada) under ACC-LAB (Europe/Canada MRA and APEC/Canada MRA)
- Recognized/Listed by FCC (USA)
- All test results contained in this engineering test report are traceable to National Institute of Standards and Technology (NIST)



## EXHIBIT 4. SUMMARY OF TEST RESULTS

### 4.1. LOCATION OF TESTS

All of the measurements described in this report were performed at Ultratech Group of Labs located in the city of Oakville, Province of Ontario, Canada.

- Radiated Emissions were performed at the Ultratech's 3 Meter Open Field Test Site (OFTS) situated in the Town of Oakville, province of Ontario.

The above site have been calibrated in accordance with ANSI C63.4, and found to be in compliance with the requirements of Sec. 2.948 of the FCC Rules. The descriptions and site measurement data of the Oakville Open Field Test Site has been filed with FCC office (FCC File No.: 31040/SIT 1300B3) and Industry Canada office (Industry Canada File No.: IC2049). Last Date of Site Calibration: Aug. 08, 2001.

### 4.2. APPLICABILITY & SUMMARY OF EMC EMISSION TEST RESULTS

FCC PARAGRAPH.	TEST REQUIREMENTS	APPLICABILITY (YES/NO)
24.229	Frequencies	No request
24.232 & 2.1046	Equivalent Isotropically Radiated Power (e.i.r.p.) Limits	Yes
24.235 & 2.1055	Frequency Stability	No Request
24.238 & 2.1051	Emission Limits (Conducted)	No Request
24.236 & 24.238, 2.1057 & 2.1053	Emission Limits (Radiated)	Yes

---

#### ULTRATECH GROUP OF LABS

3000 Bristol Circle, Oakville, Ontario, Canada L6H 6G4  
Tel. #: 905-829-1570, Fax. #: 905-829-8050, Email: [vhk.ultratech@sympatico.ca](mailto:vhk.ultratech@sympatico.ca), Website: <http://www.ultratech-labs.com>

File #: RIM19-FTX  
Sep. 14, 2001

- Assessed by ITI (UK) Competent Body, NVLAP (USA) Accreditation Body & ACA/AUSTEL (Australia), VCCI (Japan)
- Accredited by Industry Canada (Canada) under ACC-LAB (Europe/Canada MRA and APEC/Canada MRA)
- Recognized/Listed by FCC (USA)
- All test results contained in this engineering test report are traceable to National Institute of Standards and Technology (NIST)

## **EXHIBIT 5. MEASUREMENTS, EXAMINATIONS & TEST DATA FOR EMC EMISSIONS**

### **5.1. TEST PROCEDURES**

This section contains test results only. Details of test methods and procedures can be found in Exhibit 7 of this report

### **5.2. MEASUREMENT UNCERTAINTIES**

The measurement uncertainties stated were calculated in accordance with requirements of UKAS Document NIS 81 with a confidence level of 95%. Please refer to Exhibit 6 for Measurement Uncertainties.

### **5.3. MEASUREMENT EQUIPMENT USED:**

The measurement equipment used complied with the requirements of the Standards referenced in the Methods & Procedures ANSI C63.4:1992 and CISPR 16-1.

### **5.4. ESSENTIAL/PRIMARY FUNCTIONS AS DECLARED BY THE MANUFACTURER:**

The essential function of the EUT is to correctly communicate data to and from radios over RF link.

---

#### **ULTRATECH GROUP OF LABS**

3000 Bristol Circle, Oakville, Ontario, Canada L6H 6G4  
Tel. #: 905-829-1570, Fax. #: 905-829-8050, Email: [vhk.ultratech@sympatico.ca](mailto:vhk.ultratech@sympatico.ca), Website: <http://www.ultratech-labs.com>

**File #: RIM19-FTX**  
**Sep. 14, 2001**

- Assessed by ITI (UK) Competent Body, NVLAP (USA) Accreditation Body & ACA/AUSTEL (Australia), VCCI (Japan)
- Accredited by Industry Canada (Canada) under ACC-LAB (Europe/Canada MRA and APEC/Canada MRA)
- Recognized/Listed by FCC (USA)
- All test results contained in this engineering test report are traceable to National Institute of Standards and Technology (NIST)

## 5.5. EMISSION LIMITS (RADIATED) @ FCC 2.1049, 24.236 & 24.238

### 5.5.1. Limits

- The predicted or measured field strength at any location on the border of the PCS Service area shall not exceed 47 dB $\mu$ V/m unless the parties agree to a higher field strength.
- On any frequency outside a licensee's frequency block, the power of any emission shall be attenuated below the transmitter power (P) by at least 43+10log(P) dB.

### 5.5.2. Method of Measurements

The spurious/harmonic ERP measurements are using substitution method specified in Exhibit 8, § 8.2 of this report and its value in dBc is calculated as follows:

- (1) If the transmitter's antenna is an integral part of the EUT, the ERP is measured using substitution method.
- (2) If the transmitter's antenna is non-integral and diverse, the lowest ERP of the carrier with 0 dBi antenna gain is used for calculation of the spurious/harmonic emissions in dBc:  
Lowest ERP of the carrier = EIRP - 2.15 dB = P<sub>c</sub> + G - 2.15 dB = xxx dBm (conducted) + 0 dBi - 2.15 dB
- (3) Spurious /harmonic emissions levels expressed in dBc (dB below carrier) are as follows:

$$\text{ERP of spurious/harmonic (dBc)} = \text{ERP of carrier (dBm)} - \text{ERP of spurious/harmonic emission (dBm)}$$

Measuring Bandwidths:

- Outside the permitted band block: RBW = 1 MHz, VBW  $\geq$  RBW
- Inside or on the permitted band block: RBW = 1% of -26dBc Bandwidth, VBW  $\geq$  RBW

---

#### ULTRATECH GROUP OF LABS

3000 Bristol Circle, Oakville, Ontario, Canada L6H 6G4  
Tel. #: 905-829-1570, Fax. #: 905-829-8050, Email: [vhk.ultratech@sympatico.ca](mailto:vhk.ultratech@sympatico.ca), Website: <http://www.ultratech-labs.com>

File #: RIM19-FTX  
Sep. 14, 2001

- Assessed by ITI (UK) Competent Body, NVLAP (USA) Accreditation Body & ACA/AUSTEL (Australia), VCCI (Japan)
- Accredited by Industry Canada (Canada) under ACC-LAB (Europe/Canada MRA and APEC/Canada MRA)
- Recognized/Listed by FCC (USA)
- All test results contained in this engineering test report are traceable to National Institute of Standards and Technology (NIST)

### 5.5.3. Test Equipment List

Test Instruments	Manufacturer	Model No.	Serial No.	Frequency Range	Calibration Date
Spectrum Analyzer/ EMI Receiver	Hewlett Packard	HP 8546A	...	9 kHz to 5.6 GHz with built-in 30 dB Gain Pre-selector, QP, Average & Peak Detectors.	Sep. 16, 2000
Microwave Amplifier	Hewlett Packard	HP 83017A	3116A00661	1 GHz to 26.5 GHz	Apr. 20, 2001
Biconilog Antenna	EMCO	3142	9901-1347	30 MHz to 2 GHz	Nov. 13, 2000
Dipole Antenna	EMCO	3121C	8907-434	30 GHz – 1 GHz	Mar. 01, 2001
Dipole Antenna	EMCO	3121C	8907-440	30 GHz – 1 GHz	Mar. 01, 2001
Horn Antenna	EMCO	3155	9701-5061	1 GHz – 18 GHz	Apr. 27, 2001
Horn Antenna	EMCO	3155	9911-5955	1 GHz – 18 GHz	Apr. 27, 2001
Power Meter	Hewlett Packard	436A	1725A02249	10 kHz – 50 GHz, sensor dependent	Sep. 10, 2001
Power Sensor	Hewlett Packard	8481A	2702A68983	10 MHz – 18 GHz	Jan.04, 2001
Synthesize Sweeper	Hewlett Packard	83752B	3610A00457	0.01 – 20 GHz	Jan.30, 2001

#### ULTRATECH GROUP OF LABS

3000 Bristol Circle, Oakville, Ontario, Canada L6H 6G4  
 Tel. #: 905-829-1570, Fax. #: 905-829-8050, Email: [vhk.ultratech@sympatico.ca](mailto:vhk.ultratech@sympatico.ca), Website: <http://www.ultratech-labs.com>

File #: RIM19-FTX  
 Sep. 14, 2001

- Assessed by ITI (UK) Competent Body, NVLAP (USA) Accreditation Body & ACA/AUSTEL (Australia), VCCI (Japan)
- Accredited by Industry Canada (Canada) under ACC-LAB (Europe/Canada MRA and APEC/Canada MRA)
- Recognized/Listed by FCC (USA)
- All test results contained in this engineering test report are traceable to National Institute of Standards and Technology (NIST)

## 5.5.4. Test Arrangement

### 5.5.4.1. Test Configuration #1:- The EUT sit on the cradle

The EUT was placed at 3 different orthogonal positions (vertical, horizontal and flat down) for searching the highest emission level:

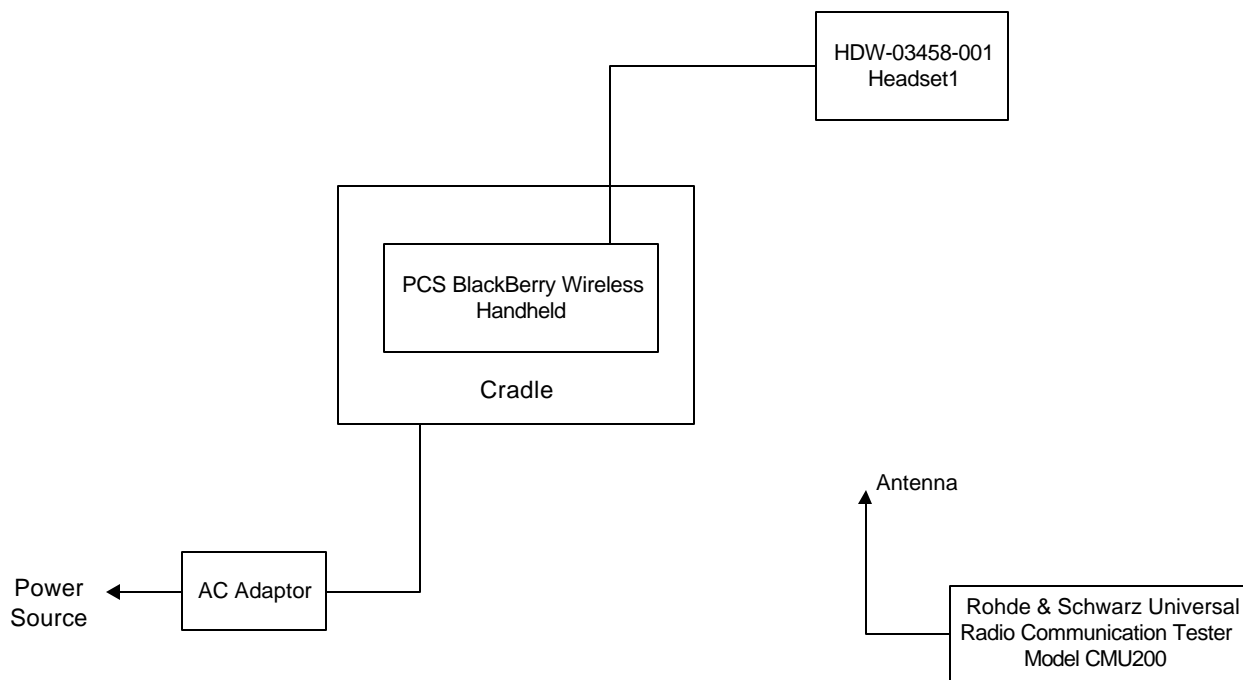

## ULTRATECH GROUP OF LABS

3000 Bristol Circle, Oakville, Ontario, Canada L6H 6G4  
Tel. #: 905-829-1570, Fax. #: 905-829-8050, Email: [vhk.ultratech@sympatico.ca](mailto:vhk.ultratech@sympatico.ca), Website: <http://www.ultratech-labs.com>

File #: RIM19-FTX  
Sep. 14, 2001

- Assessed by ITI (UK) Competent Body, NVLAP (USA) Accreditation Body & ACA/AUSTEL (Australia), VCCI (Japan)
- Accredited by Industry Canada (Canada) under ACC-LAB (Europe/Canada MRA and APEC/Canada MRA)
- Recognized/Listed by FCC (USA)
- All test results contained in this engineering test report are traceable to National Institute of Standards and Technology (NIST)

### 5.5.5. Photographs of Test Setup

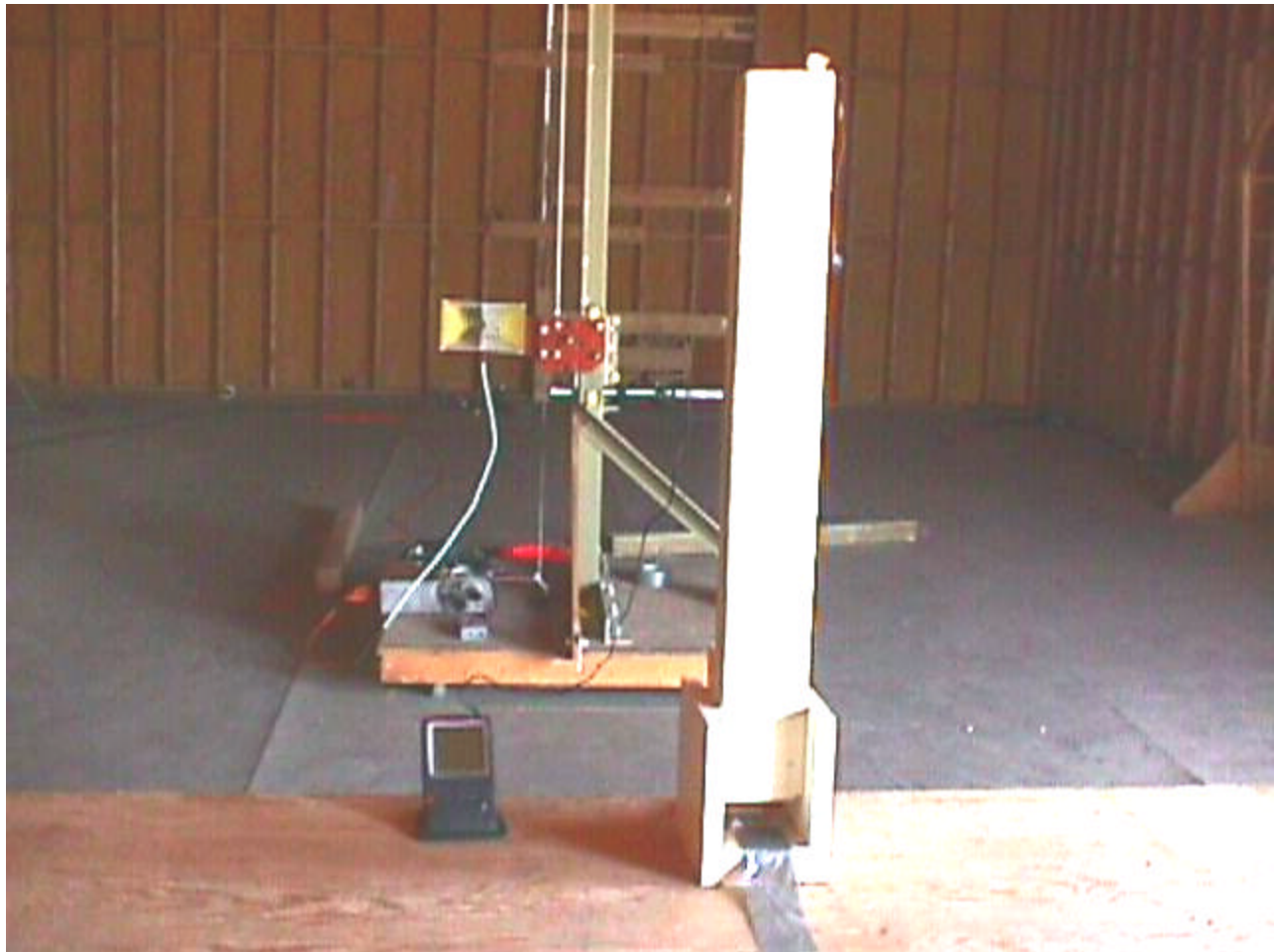

---

#### ULTRATECH GROUP OF LABS

3000 Bristol Circle, Oakville, Ontario, Canada L6H 6G4  
Tel. #: 905-829-1570, Fax. #: 905-829-8050, Email: [vhk.ultratech@sympatico.ca](mailto:vhk.ultratech@sympatico.ca), Website: <http://www.ultratech-labs.com>

File #: RIM19-FTX  
Sep. 14, 2001

- Assessed by ITI (UK) Competent Body, NVLAP (USA) Accreditation Body & ACA/AUSTEL (Australia), VCCI (Japan)
- Accredited by Industry Canada (Canada) under ACC-LAB (Europe/Canada MRA and APEC/Canada MRA)
- Recognized/Listed by FCC (USA)
- All test results contained in this engineering test report are traceable to National Institute of Standards and Technology (NIST)

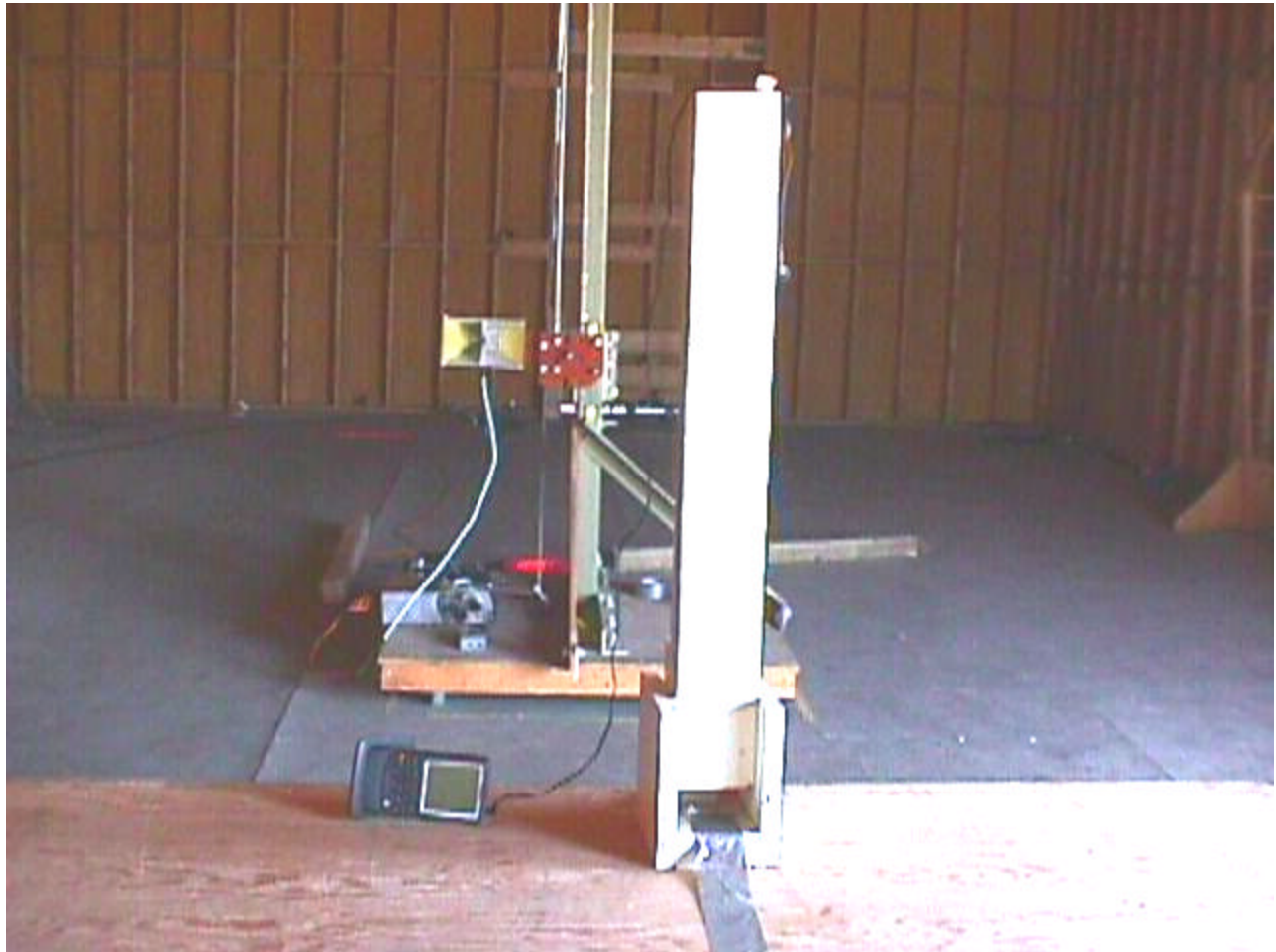

---

**ULTRATECH GROUP OF LABS**

3000 Bristol Circle, Oakville, Ontario, Canada L6H 6G4  
Tel. #: 905-829-1570, Fax. #: 905-829-8050, Email: [vhk.ultratech@sympatico.ca](mailto:vhk.ultratech@sympatico.ca), Website: <http://www.ultratech-labs.com>

**File #: RIM19-FTX**  
**Sep. 14, 2001**

- Assessed by ITI (UK) Competent Body, NVLAP (USA) Accreditation Body & ACA/AUSTEL (Australia), VCCI (Japan)
- Accredited by Industry Canada (Canada) under ACC-LAB (Europe/Canada MRA and APEC/Canada MRA)
- Recognized/Listed by FCC (USA)
- All test results contained in this engineering test report are traceable to National Institute of Standards and Technology (NIST)

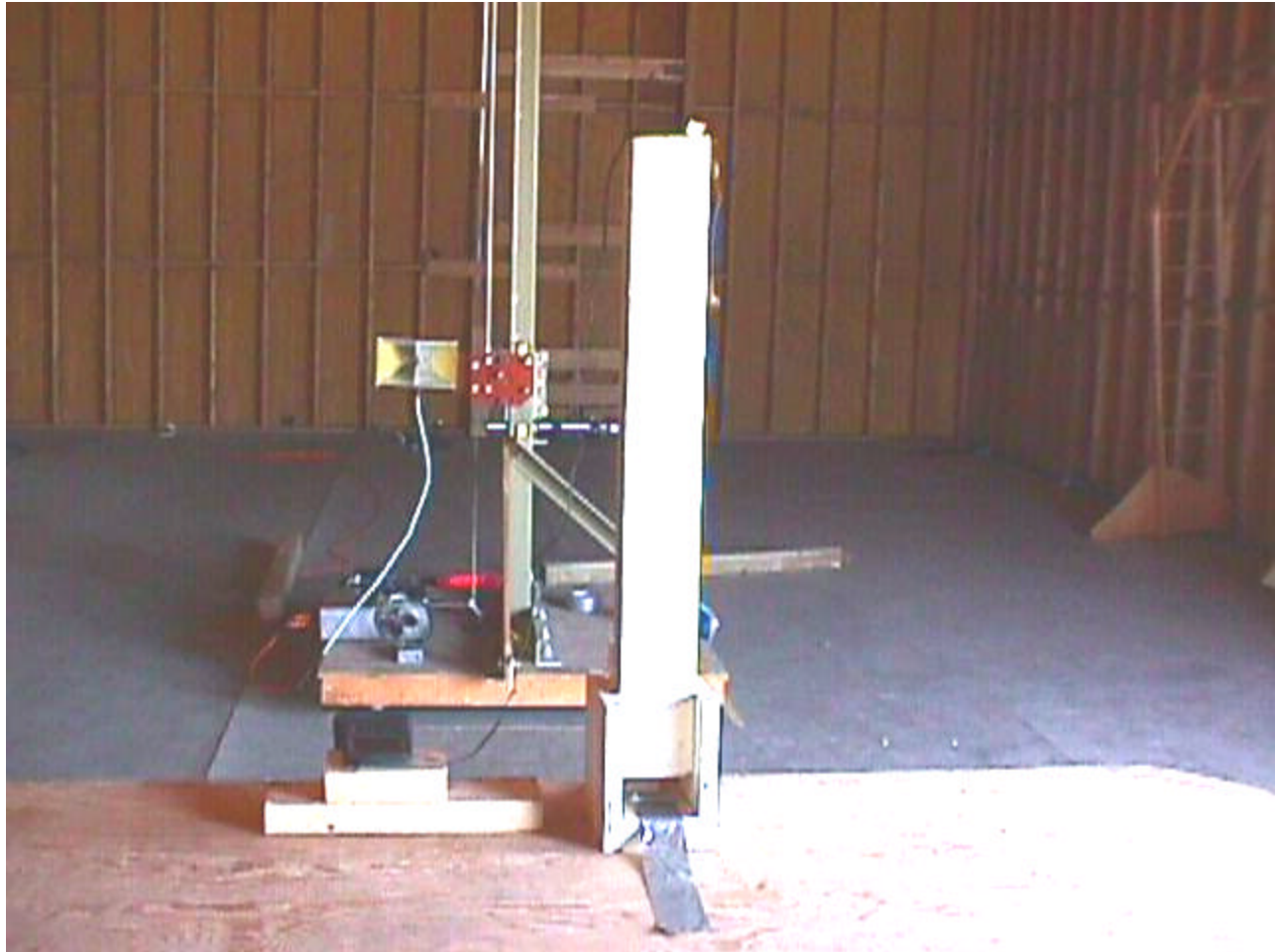

---

**ULTRATECH GROUP OF LABS**

3000 Bristol Circle, Oakville, Ontario, Canada L6H 6G4  
Tel. #: 905-829-1570, Fax. #: 905-829-8050, Email: [vhk.ultratech@sympatico.ca](mailto:vhk.ultratech@sympatico.ca), Website: <http://www.ultratech-labs.com>

**File #: RIM19-FTX**  
**Sep. 14, 2001**

- Assessed by ITI (UK) Competent Body, NVLAP (USA) Accreditation Body & ACA/AUSTEL (Australia), VCCI (Japan)
- Accredited by Industry Canada (Canada) under ACC-LAB (Europe/Canada MRA and APEC/Canada MRA)
- Recognized/Listed by FCC (USA)
- All test results contained in this engineering test report are traceable to National Institute of Standards and Technology (NIST)



**5.5.5.1. Test configurations # 2: Handheld stand-alone**

The EUT was placed at 3 different orthogonal positions (vertical, horizontal and flat down) for searching the highest emission level:

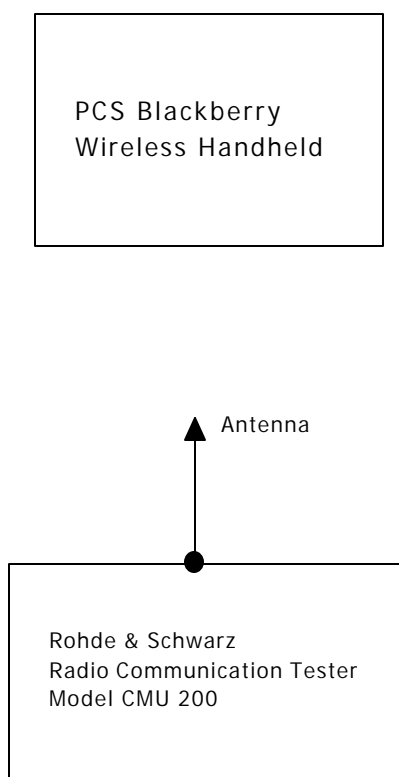

**ULTRATECH GROUP OF LABS**

3000 Bristol Circle, Oakville, Ontario, Canada L6H 6G4  
Tel. #: 905-829-1570, Fax. #: 905-829-8050, Email: [vhk.ultratech@sympatico.ca](mailto:vhk.ultratech@sympatico.ca), Website: <http://www.ultratech-labs.com>

**File #: RIM19-FTX**  
**Sep. 14, 2001**

- Assessed by ITI (UK) Competent Body, NVLAP (USA) Accreditation Body & ACA/AUSTEL (Australia), VCCI (Japan)
- Accredited by Industry Canada (Canada) under ACC-LAB (Europe/Canada MRA and APEC/Canada MRA)
- Recognized/Listed by FCC (USA)
- All test results contained in this engineering test report are traceable to National Institute of Standards and Technology (NIST)



---

**ULTRATECH GROUP OF LABS**

3000 Bristol Circle, Oakville, Ontario, Canada L6H 6G4  
Tel. #: 905-829-1570, Fax. #: 905-829-8050, Email: [yhk.ultratech@sympatico.ca](mailto:yhk.ultratech@sympatico.ca), Website: <http://www.ultratech-labs.com>

**File #: RIM19-FTX**  
**Sep. 14, 2001**

- Assessed by ITI (UK) Competent Body, NVLAP (USA) Accreditation Body & ACA/AUSTEL (Australia), VCCI (Japan)
- Accredited by Industry Canada (Canada) under ACC-LAB (Europe/Canada MRA and APEC/Canada MRA)
- Recognized/Listed by FCC (USA)
- All test results contained in this engineering test report are traceable to National Institute of Standards and Technology (NIST)



---

**ULTRATECH GROUP OF LABS**

3000 Bristol Circle, Oakville, Ontario, Canada L6H 6G4  
Tel. #: 905-829-1570, Fax. #: 905-829-8050, Email: [vhk.ultratech@sympatico.ca](mailto:vhk.ultratech@sympatico.ca), Website: <http://www.ultratech-labs.com>

**File #: RIM19-FTX**  
**Sep. 14, 2001**

- Assessed by ITI (UK) Competent Body, NVLAP (USA) Accreditation Body & ACA/AUSTEL (Australia), VCCI (Japan)
- Accredited by Industry Canada (Canada) under ACC-LAB (Europe/Canada MRA and APEC/Canada MRA)
- Recognized/Listed by FCC (USA)
- All test results contained in this engineering test report are traceable to National Institute of Standards and Technology (NIST)

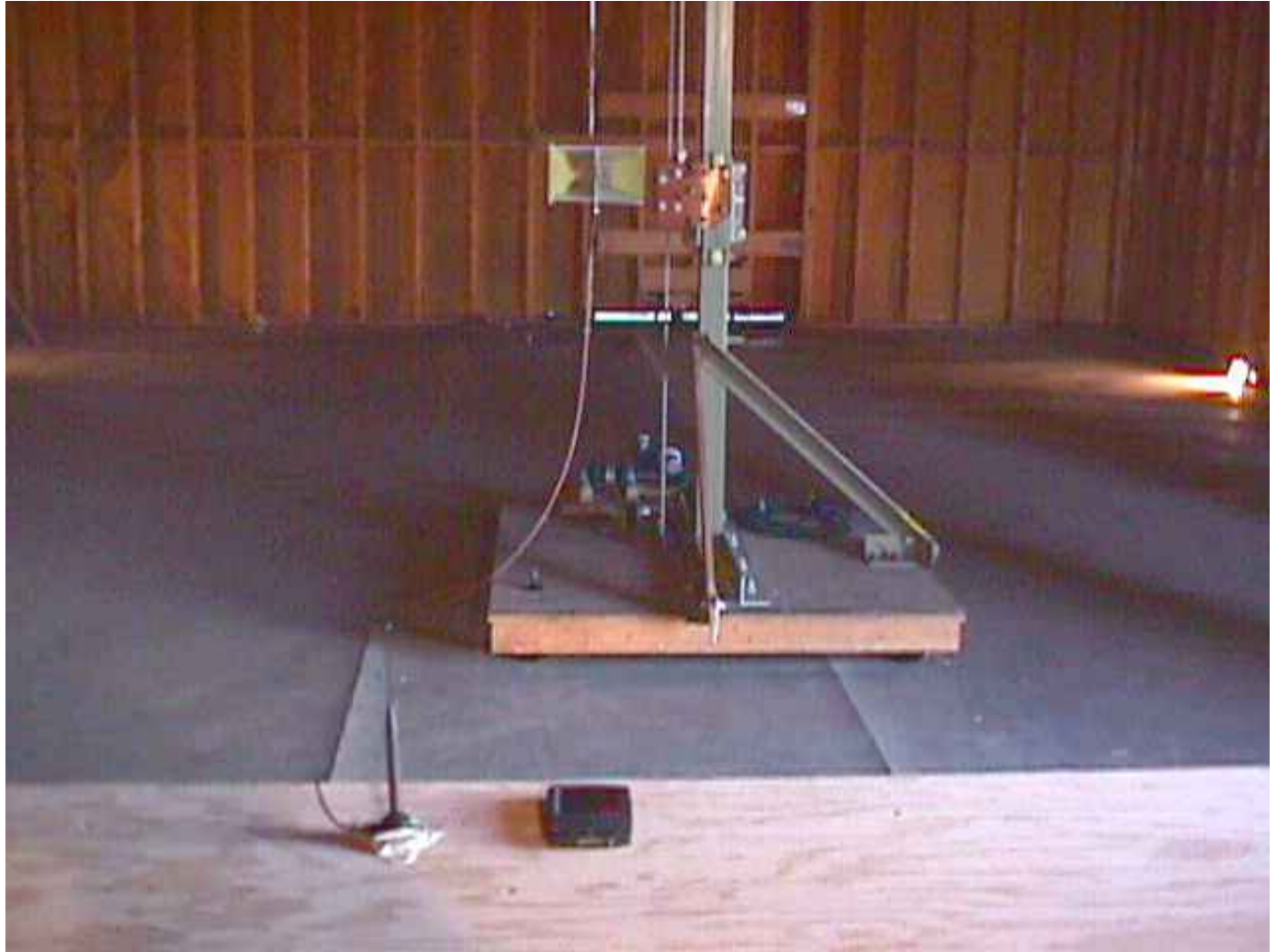

---

**ULTRATECH GROUP OF LABS**

3000 Bristol Circle, Oakville, Ontario, Canada L6H 6G4  
Tel. #: 905-829-1570, Fax. #: 905-829-8050, Email: [vhk.ultratech@sympatico.ca](mailto:vhk.ultratech@sympatico.ca), Website: <http://www.ultratech-labs.com>

**File #: RIM19-FTX**  
**Sep. 14, 2001**

- Assessed by ITI (UK) Competent Body, NVLAP (USA) Accreditation Body & ACA/AUSTEL (Australia), VCCI (Japan)
- Accredited by Industry Canada (Canada) under ACC-LAB (Europe/Canada MRA and APEC/Canada MRA)
- Recognized/Listed by FCC (USA)
- All test results contained in this engineering test report are traceable to National Institute of Standards and Technology (NIST)

## 5.5.6. Test Data

### 5.5.6.1. EIRP Measurements of the RF Output

#### 5.5.6.1.1. Test Configuration #1: Model R1900G-1-4 with Radio S/N: 351, Cradle and Headset

Frequency (MHz)	Peak E-Field @ 3m (dBμV/m)	Antenna Polarization (V/H)	Peak Power From Signal Generator (dBm)	Substitution Antenna Gain (dBi)	Measured Peak EIRP (dBm)	Peak EIRP LIMIT (dBm)
1850.2	125.5	V	Note 1	Note 1	Note 1	Note 1
	124.2	H	Note 1	Note 1	Note 1	Note 1
1880.0	126.9	V	Note 1	Note 1	Note 1	Note 1
	126.2	H	Note 1	Note 1	Note 1	Note 1
1909.8	126.4	V	Note 1	Note 1	Note 1	Note 1
	125.0	H	Note 1	Note 1	Note 1	Note 1

Note 1: The E-field measured in Test Configuration #1 was lower than that in Test Configuration #2. Therefore, the EIRP were measured with Test Configuration #2 for the worst case.

#### 5.5.6.1.2. Test Configuration #2: Model R1900G-1-4 with Radio S/N: 351, Handheld stand-alone

Frequency (MHz)	Peak E-Field @ 3m (dBμV/m)	Antenna Polarization (V/H)	Peak Power From Signal Generator (dBm)	Substitution Antenna Gain (dBi)	Measured Peak EIRP (dBm)	Peak EIRP LIMIT (dBm)
1850.2	129.9	V	23.5	7.4	30.9	33.0
	126.7	H	18.7	6.8	25.5	33.0
1880.0	129.5	V	24.7	7.4	32.1	33.0
	128.7	H	21.3	6.8	28.1	33.0
1909.8	128.2	V	24.4	7.4	31.8	33.0
	128.4	H	23.0	6.8	29.8	33.0

## ULTRATECH GROUP OF LABS

3000 Bristol Circle, Oakville, Ontario, Canada L6H 6G4  
 Tel. #: 905-829-1570, Fax. #: 905-829-8050, Email: [vhk.ultratech@sympatico.ca](mailto:vhk.ultratech@sympatico.ca), Website: <http://www.ultratech-labs.com>

File #: RIM19-FTX  
 Sep. 14, 2001

- Assessed by ITI (UK) Competent Body, NVLAP (USA) Accreditation Body & ACA/AUSTEL (Australia), VCCI (Japan)
- Accredited by Industry Canada (Canada) under ACC-LAB (Europe/Canada MRA and APEC/Canada MRA)
- Recognized/Listed by FCC (USA)
- All test results contained in this engineering test report are traceable to National Institute of Standards and Technology (NIST)

**5.5.6.2. Spurious/Harmonic Emissions**

**5.5.6.2.1. Test Configuration #1: Model R1900G-1-4 with Radio S/N: 351, Cradle and Headset**

**5.5.6.2.1.1. Lowest Frequency (1850.2 MHz)**

Fundamental Frequency:		1850.2 MHz						
RF Output Power:		Was not measured since its E-field level was less than that from the Handheld standalone configuration. Please refer to Section 5.5.6.1 of this test report for details. The spurious/harmonic emissions were conducted with the cradle and headset to ensure that there was no leakage through these cables.						
Modulation:		Internal data source						
FREQUENCY (MHz)	E-FIELD @3m (dBuV/m)	EIRP measured by Substitution Method (dBm)   (dBc)		EMI DETECTOR (Peak/QP)	ANTENNA POLARIZATIO N (H/V)	MINIMUM LIMIT (dBc)	MARGIN (dB)	PASS/ FAIL
10 – 18502	<<	<<	> 70	PEAK	V & H	43	> 30	PASS
<ul style="list-style-type: none"> <li>The emissions were scanned from 10 MHz to 20 GHz, and all emissions were found to be more than 67.2 dB below the carrier.</li> </ul>								

**5.5.6.2.1.2. Middle Frequency (1880 MHz)**

Fundamental Frequency:		1880 MHz						
RF Output Power:		Was not measured since its E-field level was less than that from the Handheld standalone configuration. Please refer to Section 5.5.6.1 of this test report for details. The spurious/harmonic emissions were conducted with the cradle and headset to ensure that there was no leakage through these cables.						
Modulation:		Internal data source						
FREQUENCY (MHz)	E-FIELD @3m (dBuV/m)	EIRP measured by Substitution Method (dBm)   (dBc)		EMI DETECTOR (Peak/QP)	ANTENNA POLARIZATIO N (H/V)	MINIMUM LIMIT (dBc)	MARGIN (dB)	PASS/ FAIL
10 – 18800	<<	<<	> 70	PEAK	V & H	41.6	> 30	PASS
<ul style="list-style-type: none"> <li>The emissions were scanned from 10 MHz to 20 GHz, and all emissions were found to be more than 73.4 dB below the carrier.</li> </ul>								

**ULTRATECH GROUP OF LABS**

3000 Bristol Circle, Oakville, Ontario, Canada L6H 6G4  
 Tel. #: 905-829-1570, Fax. #: 905-829-8050, Email: [vhk.ultratech@sympatico.ca](mailto:vhk.ultratech@sympatico.ca), Website: <http://www.ultratech-labs.com>

**File #: RIM19-FTX**  
**Sep. 14, 2001**

- Assessed by ITI (UK) Competent Body, NVLAP (USA) Accreditation Body & ACA/AUSTEL (Australia), VCCI (Japan)
- Accredited by Industry Canada (Canada) under ACC-LAB (Europe/Canada MRA and APEC/Canada MRA)
- Recognized/Listed by FCC (USA)
- All test results contained in this engineering test report are traceable to National Institute of Standards and Technology (NIST)

**5.5.6.2.1.3. Lowest Frequency (1909.8 MHz)**

Fundamental Frequency:		1909.8 MHz						
RF Output Power:		Was not measured since its E-field level was less than that from the Handheld standalone configuration. Please refer to Section 5.5.6.1 of this test report for details. The spurious/harmonic emissions were conducted with the cradle and headset to ensure that there was no leakage through these cables.						
Modulation:		Internal data source						
FREQUENCY (MHz)	E-FIELD @3m (dBuV/m)	EIRP measured by Substitution Method (dBm)   (dBc)		EMI DETECTOR (Peak/QP)	ANTENNA POLARIZATIO N (H/V)	MINIMUM LIMIT (dBc)	MARGIN (dB)	PASS/ FAIL
10 – 19098	<<	<<	> 70	PEAK	V & H	42.5	> 30	PASS
<ul style="list-style-type: none"> <li>The emissions were scanned from 10 MHz to 20 GHz, and all emissions were found to be more than 71.8 dB below the carrier.</li> </ul>								

**ULTRATECH GROUP OF LABS**

3000 Bristol Circle, Oakville, Ontario, Canada L6H 6G4  
 Tel. #: 905-829-1570, Fax. #: 905-829-8050, Email: [vhk.ultratech@sympatico.ca](mailto:vhk.ultratech@sympatico.ca), Website: <http://www.ultratech-labs.com>

**File #: RIM19-FTX**  
**Sep. 14, 2001**

- Assessed by ITI (UK) Competent Body, NVLAP (USA) Accreditation Body & ACA/AUSTEL (Australia), VCCI (Japan)
- Accredited by Industry Canada (Canada) under ACC-LAB (Europe/Canada MRA and APEC/Canada MRA)
- Recognized/Listed by FCC (USA)
- All test results contained in this engineering test report are traceable to National Institute of Standards and Technology (NIST)

## EXHIBIT 6. MEASUREMENT UNCERTAINTY

The measurement uncertainties stated were calculated in accordance with the requirements of NIST Technical Note 1297 and NIS 81 (1994)

### 6.1. RADIATED EMISSION MEASUREMENT UNCERTAINTY

CONTRIBUTION (Radiated Emissions)	PROBABILITY DISTRIBUTION	UNCERTAINTY ( $\pm$ dB)	
		3 m	10 m
Antenna Factor Calibration	Normal (k=2)	$\pm 1.0$	$\pm 1.0$
Cable Loss Calibration	Normal (k=2)	$\pm 0.3$	$\pm 0.5$
EMI Receiver specification	Rectangular	$\pm 1.5$	$\pm 1.5$
Antenna Directivity	Rectangular	+0.5	+0.5
Antenna factor variation with height	Rectangular	$\pm 2.0$	$\pm 0.5$
Antenna phase center variation	Rectangular	0.0	$\pm 0.2$
Antenna factor frequency interpolation	Rectangular	$\pm 0.25$	$\pm 0.25$
Measurement distance variation	Rectangular	$\pm 0.6$	$\pm 0.4$
Site imperfections	Rectangular	$\pm 2.0$	$\pm 2.0$
Mismatch: Receiver VRC $\Gamma_1 = 0.2$ Antenna VRC $\Gamma_R = 0.67(\text{Bi}) 0.3 (\text{Lp})$ Uncertainty limits $20\text{Log}(1 \pm \Gamma_1 \Gamma_R)$	U-Shaped	+1.1 -1.25	$\pm 0.5$
System repeatability	Std. Deviation	$\pm 0.5$	$\pm 0.5$
Repeatability of EUT		-	-
Combined standard uncertainty	Normal	+2.19 / -2.21	+1.74 / -1.72
Expanded uncertainty U	Normal (k=2)	+4.38 / -4.42	+3.48 / -3.44

Calculation for maximum uncertainty when 3m biconical antenna including a factor of k=2 is used:

$$U = 2u_c(y) = 2x(+2.19) = +4.38 \text{ dB} \quad \text{And} \quad U = 2u_c(y) = 2x(-2.21) = -4.42 \text{ dB}$$

#### ULTRATECH GROUP OF LABS

3000 Bristol Circle, Oakville, Ontario, Canada L6H 6G4  
 Tel. #: 905-829-1570, Fax. #: 905-829-8050, Email: [vhk.ultratech@sympatico.ca](mailto:vhk.ultratech@sympatico.ca), Website: <http://www.ultratech-labs.com>

File #: RIM19-FTX  
 Sep. 14, 2001

- Assessed by ITI (UK) Competent Body, NVLAP (USA) Accreditation Body & ACA/AUSTEL (Australia), VCCI (Japan)
- Accredited by Industry Canada (Canada) under ACC-LAB (Europe/Canada MRA and APEC/Canada MRA)
- Recognized/Listed by FCC (USA)
- All test results contained in this engineering test report are traceable to National Institute of Standards and Technology (NIST)



## EXHIBIT 7. MEASUREMENT METHODS

### 7.1. RADIATED POWER MEASUREMENTS (ERP & EIRP) USING SUBSTITUTION METHOD

#### 7.1.1. Maximizing RF Emission Level (E-Field)

- (a) The measurements was performed with full rf output power and modulation.
- (b) Test was performed at listed 3m open area test site (listed with FCC, IC, ITI, NVLAP, ACA & VCCI).
- (c) The transmitter under test was placed at the specified height on a non-conducting turntable (80 cm height)
- (d) The BICONILOG antenna (20 MHz to 1 GHz) or HORN antenna (1 GHz to 18 GHz) was used for measuring.
- (e) Load an appropriate correction factors file in EMI Receiver for correcting the field strength reading level

Total Correction Factor recorded in the EMI Receiver = Cable Loss + Antenna Factor  
 $E \text{ (dBuV/m)} = \text{Reading (dBuV)} + \text{Total Correction Factor (dB/m)}$

- (f) Set the EMI Receiver #1 and #2 as follows:

Center Frequency:	test frequency
Resolution BW:	100 kHz
Video BW:	same
Detector Mode:	positive
Average:	off
Span:	3 x the signal bandwidth

- (g) The test antenna was lowered or raised from 1 to 4 meters until the maximum signal level was detected.
- (h) The transmitter was rotated through  $360^{\circ}$  about a vertical axis until a higher maximum signal was received.
- (i) The test antenna was lowered or raised again from 1 to 4 meters until a maximum was obtained. This level was recorded.
- (j) The recorded reading was corrected to the true field strength level by adding the antenna factor, cable loss and subtracting the pre-amplifier gain.
- (k) The above steps were repeated with both transmitters' antenna and test receiving antenna placed in vertical and horizontal polarization. Both readings with the antennas placed in vertical and horizontal polarization shall be recorded.
- (l) Repeat for all different test signal frequencies

---

#### ULTRATECH GROUP OF LABS

3000 Bristol Circle, Oakville, Ontario, Canada L6H 6G4  
Tel. #: 905-829-1570, Fax. #: 905-829-8050, Email: [vhk.ultratech@sympatico.ca](mailto:vhk.ultratech@sympatico.ca), Website: <http://www.ultratech-labs.com>

File #: RIM19-FTX  
Sep. 14, 2001

- Assessed by ITI (UK) Competent Body, NVLAP (USA) Accreditation Body & ACA/AUSTEL (Australia), VCCI (Japan)
- Accredited by Industry Canada (Canada) under ACC-LAB (Europe/Canada MRA and APEC/Canada MRA)
- Recognized/Listed by FCC (USA)
- All test results contained in this engineering test report are traceable to National Institute of Standards and Technology (NIST)

## 7.1.2. Measuring the EIRP of Spurious/Harmonic Emissions using Substitution Method

- (a) Set the EMI Receiver (for measuring E-Field) and Receiver #2 (for measuring EIRP) as follows:

Center Frequency: equal to the signal source  
Resolution BW: 10 kHz  
Video BW: same  
Detector Mode: positive  
Average: off  
Span: 3 x the signal bandwidth

- (b) Load an appropriate correction factors file in EMI Receiver for correcting the field strength reading level

Total Correction Factor recorded in the EMI Receiver = Cable Loss + Antenna Factor  
 $E \text{ (dBuV/m)} = \text{Reading (dBuV)} + \text{Total Correction Factor (dB/m)}$

- (c) Select the frequency and E-field levels obtained in the Section 8.2.1 for ERP/EIRP measurements.

- (d) Substitute the EUT by a signal generator and one of the following transmitting antenna (substitution antenna):

- ◆ DIPOLE antenna for frequency from 30-1000 MHz or
- ◆ HORN antenna for frequency above 1 GHz }.
- (e) Mount the transmitting antenna at 1.5 meter high from the ground plane.
- (f) Use one of the following antenna as a receiving antenna:
  - ◆ DIPOLE antenna for frequency from 30-1000 MHz or
  - ◆ HORN antenna for frequency above 1 GHz }.
- (g) If the DIPOLE antenna is used, tune it's elements to the frequency as specified in the calibration manual.
- (h) Adjust both transmitting and receiving antenna in a VERTICAL polarization.
- (i) Tune the EMI Receivers to the test frequency.
- (j) Lower or raise the test antenna from 1 to 4 meters until the maximum signal level was detected.
- (k) The transmitter was rotated through 360° about a vertical axis until a higher maximum signal was received.
- (l) Lower or raise the test antenna from 1 to 4 meters until the maximum signal level was detected.
- (m) Adjust input signal to the substitution antenna until an equal or a known related level to that detected from the transmitter was obtained in the test receiver.
- (n) Record the power level read from the Average Power Meter and calculate the ERP/EIRP as follows:

$$P = P1 - L1 = (P2 + L2) - L1 = P3 + A + L2 - L1$$

$$EIRP = P + G1 = P3 + L2 - L1 + A + G1$$

$$ERP = EIRP - 2.15 \text{ dB}$$

$$\text{Total Correction factor in EMI Receiver \# 2} = L2 - L1 + G1$$

Where: P: Actual RF Power fed into the substitution antenna port after corrected.

P1: Power output from the signal generator

P2: Power measured at attenuator A input

P3: Power reading on the Average Power Meter

EIRP: EIRP after correction

ERP: ERP after correction

- (o) Adjust both transmitting and receiving antenna in a HORIZONTAL polarization, then repeat step (k) to (o)
- (p) Repeat step (d) to (o) for different test frequency
- (q) Repeat steps (c) to (j) with the substitution antenna oriented in horizontal polarization.
- (r) Actual gain of the EUT's antenna is the difference of the measured EIRP and measured RF power at the RF port. Correct the antenna gain if necessary.:

---

### ULTRATECH GROUP OF LABS

3000 Bristol Circle, Oakville, Ontario, Canada L6H 6G4  
Tel. #: 905-829-1570, Fax. #: 905-829-8050, Email: [vhk.ultratech@sympatico.ca](mailto:vhk.ultratech@sympatico.ca), Website: <http://www.ultratech-labs.com>

File #: RIM19-FTX  
Sep. 14, 2001

- Assessed by ITI (UK) Competent Body, NVLAP (USA) Accreditation Body & ACA/AUSTEL (Australia), VCCI (Japan)
- Accredited by Industry Canada (Canada) under ACC-LAB (Europe/Canada MRA and APEC/Canada MRA)
- Recognized/Listed by FCC (USA)
- All test results contained in this engineering test report are traceable to National Institute of Standards and Technology (NIST)

Figure 2

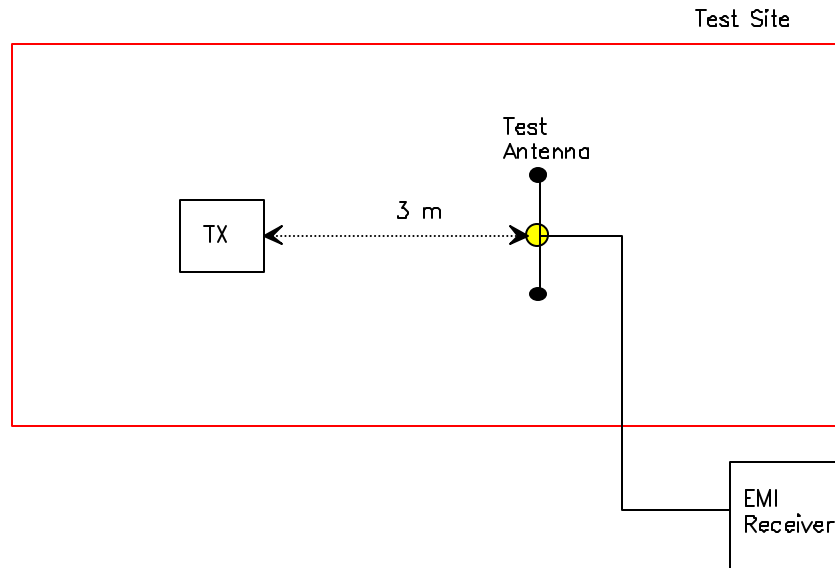
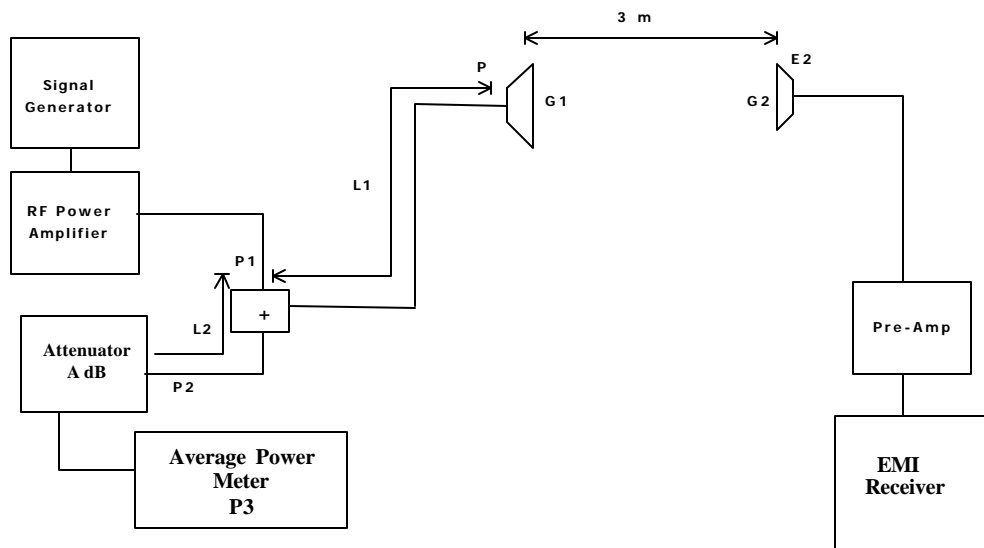

Figure 3



**ULTRATECH GROUP OF LABS**

3000 Bristol Circle, Oakville, Ontario, Canada L6H 6G4  
 Tel. #: 905-829-1570, Fax. #: 905-829-8050, Email: [vhk.ultratech@sympatico.ca](mailto:vhk.ultratech@sympatico.ca), Website: <http://www.ultratech-labs.com>

File #: RIM19-FTX  
 Sep. 14, 2001

- Assessed by ITI (UK) Competent Body, NVLAP (USA) Accreditation Body & ACA/AUSTEL (Australia), VCCI (Japan)
- Accredited by Industry Canada (Canada) under ACC-LAB (Europe/Canada MRA and APEC/Canada MRA)
- Recognized/Listed by FCC (USA)
- All test results contained in this engineering test report are traceable to National Institute of Standards and Technology (NIST)