

FCC Test Report

Report No.: RFBFKV-WTW-P24010541-2

FCC ID: L6AITK100-1

Test Model: ITK100-1

Received Date: 2024/1/24

Test Date: 2024/1/26 ~ 2024/2/2

Issued Date: 2024/3/11

Applicant: BlackBerry

Address: 2200 University Ave E, Waterloo, ON N2K 0A7

Issued By: Bureau Veritas Consumer Products Services (H.K.) Ltd., Taoyuan Branch
Lin Kou Laboratories

Lab Address: No. 47-2, 14th Ling, Chia Pau Vil., Lin Kou Dist., New Taipei City, Taiwan

Test Location (1): No. 19, Hwa Ya 2nd Rd., Wen Hwa Vil., Kwei Shan Dist., Taoyuan City
33383, Taiwan

FCC Registration /

Designation Number (1): 788550 / TW0003

Test Location (2): No. 70, Wenming Rd., Guishan Dist., Taoyuan City 333, Taiwan (R.O.C.)

FCC Registration /

Designation Number (2): 281270 / TW0032



This report is governed by, and incorporates by reference, the Conditions of Testing as posted at the date of issuance of this report at <http://www.bureauveritas.com/home/about-us/our-business/cps/about-us/terms-conditions/> and is intended for your exclusive use. Any copying or replication of this report to or for any other person or entity, or use of our name or trademark, is permitted only with our prior written permission. This report sets forth our findings solely with respect to the test samples identified herein. The results set forth in this report are not indicative or representative of the quality or characteristics of the lot from which a test sample was taken or any similar or identical product unless specifically and expressly noted. Our report includes all of the tests requested by you and the results thereof based upon the information that you provided to us. Measurement uncertainty is only provided upon request for accredited tests. Statements of conformity are based on simple acceptance criteria without taking measurement uncertainty into account, unless otherwise requested in writing. You have 60 days from date of issuance of this report to notify us of any material error or omission caused by our negligence or if you require measurement uncertainty; provided, however, that such notice shall be in writing and shall specifically address the issue you wish to raise. A failure to raise such issue within the prescribed time shall constitute your unqualified acceptance of the completeness of this report, the tests conducted and the correctness of the report contents.

Table of Contents

Release Control Record	3
1 Certificate of Conformity	4
2 Summary of Test Results	5
2.1 Measurement Uncertainty.....	5
2.2 Modification Record.....	5
3 General Information	6
3.1 General Description of EUT.....	6
3.2 Description of Test Modes.....	7
3.2.1 Test Mode Applicability and Tested Channel Detail.....	7
3.3 Duty Cycle of Test Signal.....	8
3.4 Description of Support Units.....	9
3.4.1 Configuration of System under Test.....	9
3.5 General Description of Applied Standards and references.....	9
4 Test Types and Results	10
4.1 Radiated Power and Unwanted Emission Measurement.....	10
4.1.1 Limits of Radiated Power and Unwanted Emission Measurement.....	10
4.1.2 Test Instruments.....	11
4.1.3 Test Procedures.....	14
4.1.4 Deviation from Test Standard.....	16
4.1.5 Test Setup.....	16
4.1.6 EUT Operating Conditions.....	17
4.1.7 Test Results.....	18
4.2 Modulation characteristics Measurement.....	34
4.3 Occupied Bandwidth Measurement.....	35
4.3.1 Test Setup.....	35
4.3.2 Test Instruments.....	35
4.3.3 Test Procedure.....	35
4.3.4 Deviation from Test Standard.....	35
4.3.5 EUT Operating Conditions.....	35
4.3.6 Test Results.....	36
4.4 Frequency Stability Measurement.....	38
4.4.1 Limits of Frequency Stability Measurement.....	38
4.4.2 Test Instruments.....	38
4.4.3 Test Procedure.....	38
4.4.4 Test Setup.....	39
4.4.5 Test Results.....	40
5 Pictures of Test Arrangements	42
Appendix – Information of the Testing Laboratories	43

Release Control Record

Issue No.	Description	Date Issued
RFBFKV-WTW-P24010541-2	Original release.	2024/3/11

1 Certificate of Conformity

Product: Radar R2 IS

Brand: BlackBerry

Test Model: ITK100-1

Sample Status: Engineering sample

Applicant: BlackBerry

Test Date: 2024/1/26 ~ 2024/2/2

Standards: 47 CFR FCC Part 95, Subpart M
ANSI C63.10-2013

The above equipment has been tested by **Bureau Veritas Consumer Products Services (H.K.) Ltd., Taoyuan Branch**, and found compliance with the requirement of the above standards. The test record, data evaluation & Equipment Under Test (EUT) configurations represented herein are true and accurate accounts of the measurements of the sample's RF characteristics under the conditions specified in this report.

Prepared by :  , **Date:** 2024/3/11
Polly Chien / Specialist

Approved by :  , **Date:** 2024/3/11
Jeremy Lin / Project Engineer

2 Summary of Test Results

47 CFR FCC Part 95, Subpart M			
FCC Clause	Test Item	Result	Remarks
95.3367 (a)/(b)	Equivalent Isotropically Radiated Power (EIRP) Test	PASS	Meet the requirement of limit.
95.3379(a)	Unwanted Emission Test	PASS	Meet the requirement of limit.
95.3379(b)	Frequency Stability Test	PASS	Meet the requirement of limit.
2.1049	Occupied Bandwidth Measurement	PASS	Meet the requirement of limit.
2.1047	Modulation characteristics	PASS	Meet the requirement

Note: Determining compliance based on the results of the compliance measurement, not taking into account measurement instrumentation uncertainty.

2.1 Measurement Uncertainty

Where relevant, the following measurement uncertainty levels have been estimated for tests performed on the EUT as specified in CISPR 16-4-2:

Measurement	Frequency	Expanded Uncertainty
		(k=2) (\pm)
Conducted Emissions at mains ports	150kHz ~ 30MHz	2.79 dB
Radiated Emissions	9kHz ~ 30MHz	3.04 dB
	30MHz ~ 200MHz	3.59 dB
	200MHz ~ 1000MHz	3.60 dB
	1GHz ~ 18GHz	2.29 dB
	18GHz ~ 40GHz	2.29 dB
	40GHz ~ 66GHz	4.59 dB
	66GHz ~ 100GHz	5.37 dB
	Above 100GHz	5.40 dB

2.2 Modification Record

There were no modifications required for compliance.

3 General Information

3.1 General Description of EUT

Product	Radar R2 IS
Brand	BlackBerry
Test Model	ITK100-1
Status of EUT	Engineering sample
Power Supply Rating	3.6Vdc from battery
Modulation Type	FMCW
Operating Frequency	77-81GHz
Output Power (EIRP)	78.82 GHz: 24.72dBm (PK) 78.98 GHz: 24.14dBm (PK)
Antenna Type	Refer to Note
Antenna Connector	Refer to Note
Accessory Device	Refer to Note
Data Cable Supplied	NA

Note:

1. 77GHz radar device and other technology can't transmit at the same time.
2. The EUT uses following accessories.

Battery		
Brand	Model	Specification
Blackberry	BAT-63845-001	Power Rating : 3.6V, 19Ah

3. The antennas provided to the EUT, please refer to the following table:

Antenna No.	Frequency Range (GHz)	Antenna Net Gain (dBi)	Antenna Type	Connector
1	77~81	20.2	antennas on chip with external Horn Waveguide	N/A

*Detail antenna specification please refer to antenna datasheet and/or antenna measurement report.

4. The above EUT information is declared by manufacturer and for more detailed features description, please refer to the manufacturer's specifications or user's manual.

3.2 Description of Test Modes

2 channels are provided for EUT.

Channel's Number	1	2
Frequency (GHz)	78.82	78.98

3.2.1 Test Mode Applicability and Tested Channel Detail

EUT CONFIGURE MODE	APPLICABLE TO				DESCRIPTION
	RE \geq 1G	RE<1G	FS	OB	
-	√	√	√	√	-

Where RE \geq 1G: Radiated Emission above 1GHz– RE<1G: Radiated Emission below 1GHz
 FS: Frequency Stability OB: Occupied Bandwidth measurement

Note: The EUT had been pre-tested on the positioned of each 3 axis. The worst case was found when positioned on **Y-axis**.

Radiated Emission Test (Below 1GHz):

- Pre-Scan has been conducted to determine the worst-case mode from all possible combinations between available modulations, data rates and antenna ports (if EUT with antenna diversity architecture).
- Following channel(s) was (were) selected for the final test as listed below.

AVAILABLE CHANNEL	TESTED CHANNEL	MODULATION TYPE
1, 2	1, 2	FMCW

Radiated Emission Test (Above 1GHz):

- Pre-Scan has been conducted to determine the worst-case mode from all possible combinations between available modulations, data rates and antenna ports (if EUT with antenna diversity architecture).
- Following channel(s) was (were) selected for the final test as listed below.

AVAILABLE CHANNEL	TESTED CHANNEL	MODULATION TYPE
1, 2	1, 2	FMCW

Frequency Stability Test:

- Following channel(s) was (were) selected for the final test as listed below.

AVAILABLE CHANNEL	TESTED CHANNEL	MODULATION TYPE
1, 2	1, 2	FMCW

Occupied Bandwidth Test:

- Pre-Scan has been conducted to determine the worst-case mode from all possible combinations between available modulations, data rates and antenna ports (if EUT with antenna diversity architecture).
- Following channel(s) was (were) selected for the final test as listed below.

AVAILABLE CHANNEL	TESTED CHANNEL	MODULATION TYPE
1, 2	1, 2	FMCW

Test Condition:

APPLICABLE TO	ENVIRONMENTAL CONDITIONS	INPUT POWER	TESTED BY
RE \geq 1G	23deg. C, 67%RH	3.6Vdc	Wade Huang
RE<1G	23deg. C, 68%RH	3.6Vdc	Wade Huang
FS	23deg. C, 68%RH	3.6Vdc	Wade Huang
OB	23deg. C, 68%RH	3.6Vdc	Wade Huang

3.3 Duty Cycle of Test Signal

Test Frequency (GHz)	T on (ms)	T on+off (ms)	Duty cycle (%)
78.819	7	200	3.5

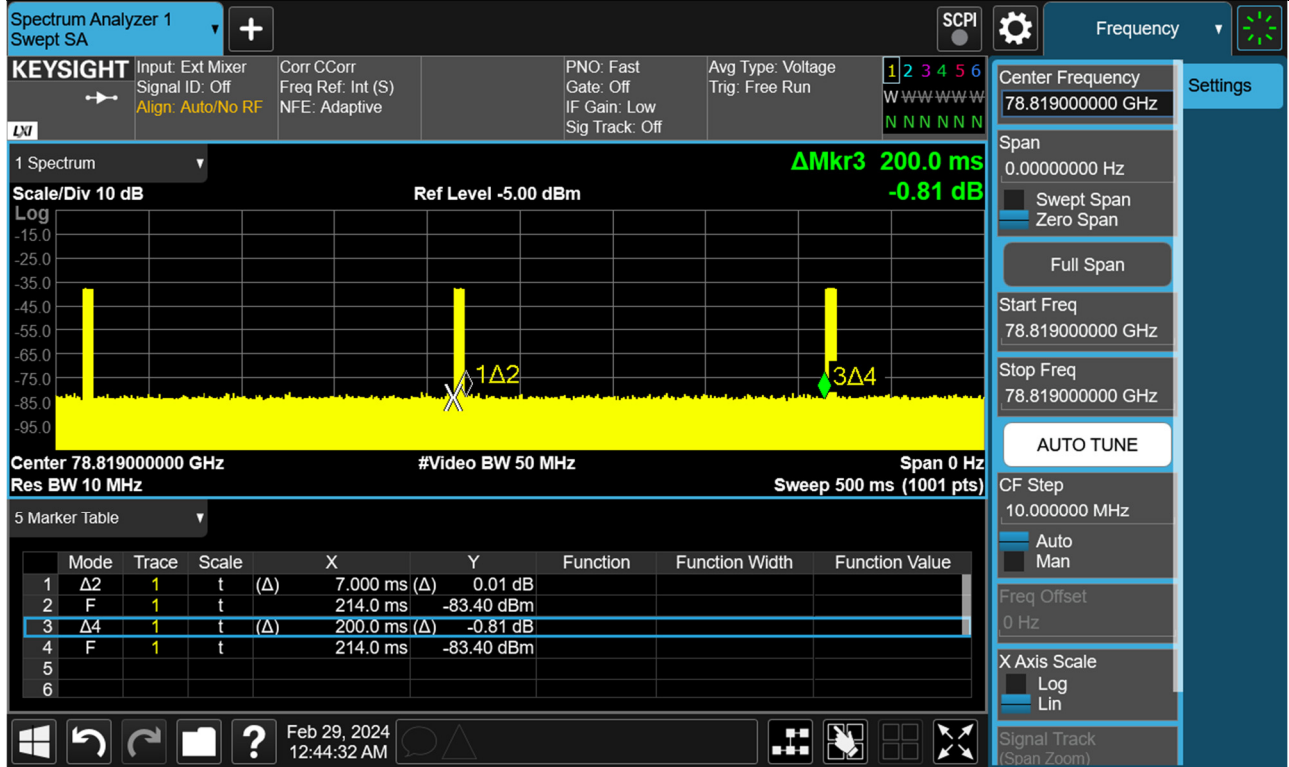

Test Frequency (GHz)	T on (ms)	T on+off (ms)	Duty cycle (%)
78.984	7	201	3.48

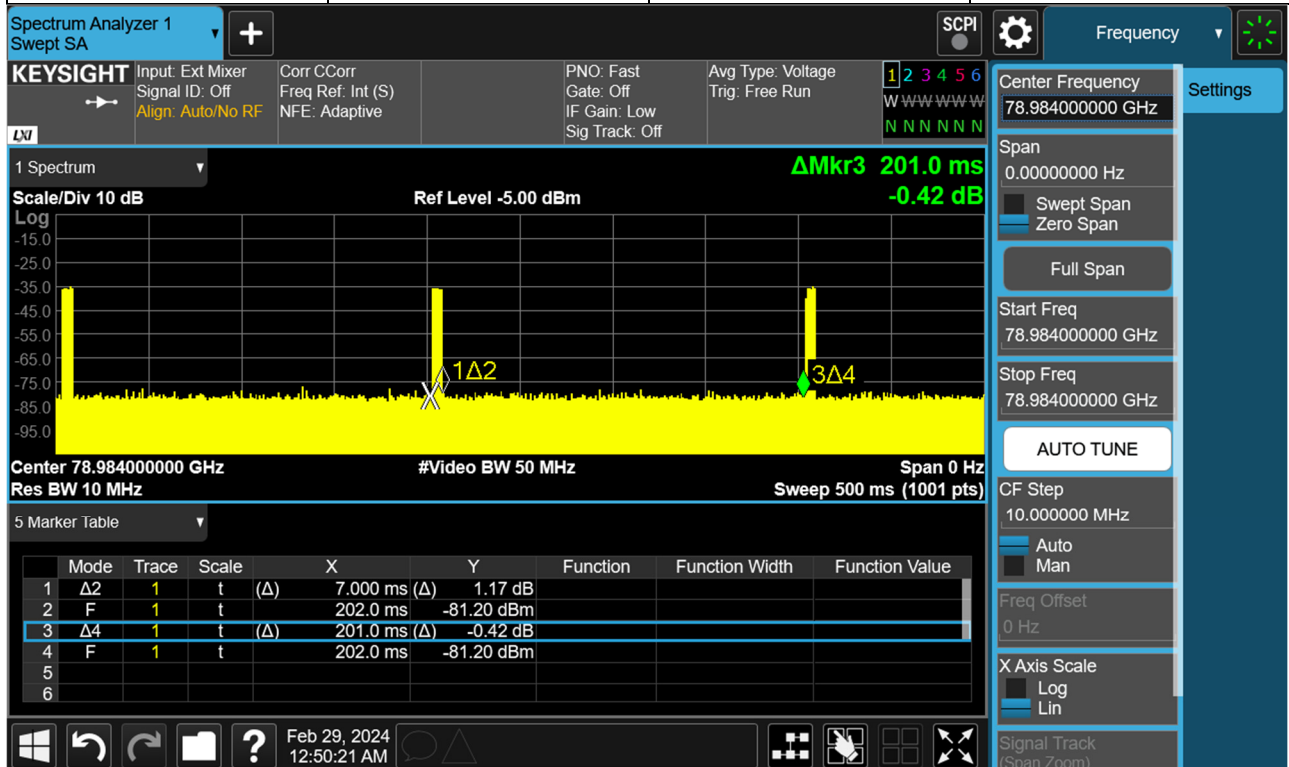

3.4 Description of Support Units

The EUT has been tested as an independent unit together with other necessary accessories or support units.

3.4.1 Configuration of System under Test



3.5 General Description of Applied Standards and references

The EUT is a RF Product. According to the specifications of the manufacturer, it must comply with the requirements of the following standards and references:

Test standard:

FCC Part 95, Subpart M

ANSI 63.10-2013

All test items have been performed and recorded as per the above standards.

References Test Guidance:

653005 D01 76-81 GHz Radars v01r02

All test items have been performed as a reference to the above KDB test guidance.

4 Test Types and Results

4.1 Radiated Power and Unwanted Emission Measurement

4.1.1 Limits of Radiated Power and Unwanted Emission Measurement

According to 95.3367 the field strength of emissions from intentional radiators operated under these frequencies bands shall not exceed the following:

Fundamental Frequency (GHz)	Equivalent Isotropically Radiated Power (EIRP)	
	Peak	Average
76 ~ 81	55 dBm/MHz	50 dBm

According to 95.3379 the power density of any emissions outside the 76-81 GHz band shall consist solely of spurious emissions and shall not exceed the following:

(1) Radiated emissions below 40 GHz shall not exceed the field strength as shown in the following emissions table.

Frequencies (MHz)	Field strength (microvolts/meter)	Measurement distance (meters)
0.009-0.490	2400/F(kHz)	300
0.490-1.705	24000/F(kHz)	30
1.705-30.0	30	30
30-88	100	3
88-216	150	3
216-960	200	3
Above 960	500	3

NOTE:

- The tighter limit applies at the band edges.
- The limits are based on the frequency of the unwanted emissions and not the fundamental frequency. However, the level of any unwanted emissions shall not exceed the level of the fundamental frequency.
- The emissions limits are based on measurements employing a CISPR quasi-peak detector except for the frequency bands 9.0-90.0 kHz, 110.0-490.0 kHz, and above 1000 MHz. Radiated emissions limits in these three bands are based on measurements employing an average detector.

(2) The power density of radiated emissions outside the 76-81 GHz band above 40.0 GHz shall not exceed the following, based on measurements employing an average detector with a 1 MHz RBW:

(i) For radiated emissions outside the 76-81 GHz band between 40 GHz and 200 GHz from field disturbance sensors and radar systems operating in the 76-81 GHz band: 600 pW/cm² at a distance of 3 meters from the exterior surface of the radiating structure.

(ii) For radiated emissions above 200 GHz from field disturbance sensors and radar systems operating in the 76-81 GHz band: 1000 pW/cm² at a distance of 3 meters from the exterior surface of the radiating structure.

(3) For field disturbance sensors and radar systems operating in the 76-81 GHz band, the spectrum shall be investigated up to 231.0 GHz.

4.1.2 Test Instruments

For Below 40GHz and Frequency Stability

Description & Manufacturer	Model No.	Serial No.	Cal. Date	Cal. Due
Test Receiver Rohde & Schwarz	ESR3	102579	Jul. 04, 2023	Jul. 03, 2024
Spectrum Analyzer KEYSIGHT	N9020B	MY60110462	Mar. 07, 2023	Mar. 06, 2024
BILOG Antenna SCHWARZBECK	VULB9168	9168-995	Oct. 16, 2023	Oct. 15, 2024
HORN Antenna SCHWARZBECK	BBHA 9120 D	9120D-404	Nov. 12, 2023	Nov. 11, 2024
HORN Antenna SCHWARZBECK	BBHA 9170	995	Nov. 12, 2023	Nov. 11, 2024
Loop Antenna EMCI	EM-6879	269	Sep. 23, 2023	Sep. 22, 2024
Preamplifier EMCI	EMC330N	980783	Jan. 15, 2024	Jan. 14, 2025
Preamplifier EMCI	EMC118A45SE	980810	Dec. 28, 2023	Dec. 27, 2024
Preamplifier EMCI	EMC184045SE	980787	Jan. 15, 2024	Jan. 14, 2025
RF signal cable EMCI	EMC104-SM-SM-(9000+20 00+1000)	201230+ 201242+ 210101	Jan. 15, 2024	Jan. 14, 2025
RF signal cable EMCI	EMCCFD400-NM-NM-(900 0+300+500)	201252+ 201250+ 201245	Jan. 15, 2024	Jan. 14, 2025
RF signal cable EMCI	EMC101G-KM-KM-(5000+ 3000+2000)	201261+201258+ 201249	Jan. 15, 2024	Jan. 14, 2025
Software BV CPS	ADT_Radiated_V7.6.15.9.5	NA	NA	NA
Turn Table Max-Full	MFT-151SS-0.5T	NA	NA	NA
Turn Table Controller Max-Full	MF-7802BS	MF780208675	NA	NA
Antenna Tower KaiTuo	NA	NA	NA	NA
Antenna Tower Controller KaiTuo	KT-2000	NA	NA	NA
Boresight Antenna Fixture	FBA-01	FBA-SIP01	NA	NA
Temperature & Humidity Chamber Terchy	MHU-225AU	920842	Jun. 17, 2023	Jun. 16, 2024
Digital Storage Oscilloscope Keysight	DSO-X 6004A	MY55190202	Jun. 20, 2023	Jun. 19, 2024

- Note: 1. The calibration interval of the above test instruments is 12 months and the calibrations are traceable to NML/ROC and NIST/USA.
 2. The test was performed in WM Chamber 7.
 3. Test date: 2024/2/2

For Above 40GHz:

Description & Manufacturer	Model No.	Serial No.	Cal. Date	Cal. Due
Spectrum Analyzer Keysight	N9030A	MY55330160	Feb. 07, 2023	Feb. 06, 2024
OXE89 Horn Antenna (33~55GHz) QuinStar	QWH-UCRR00	QWH-QPRR00-2	Apr. 25, 2023	Apr. 24, 2024
Conical Horn Antenna (50~75GHz) Keysight	WR15CH-Conical	RCH015RL-2	Apr. 25, 2023	Apr. 24, 2024
Conical Horn Antenna (75~110GHz) Keysight	WR10CH-Conical	RCH010RL-2	Apr. 25, 2023	Apr. 24, 2024
Conical Horn Antenna (110~170GHz) Keysight	WR6.5CH-Conical	RCH06RL-1	Apr. 25, 2023	Apr. 24, 2024
Conical Horn Antenna (170~220GHz) Keysight	WR5.1CH-Conical	RCH05RL-1	Apr. 25, 2023	Apr. 24, 2024
Conical Horn Antenna (220~325GHz) Keysight	WR3.4DH-Diagonal	WR3.4DHR4 5-11	Apr. 25, 2023	Apr. 24, 2024
N9029AV15-DC9 - 50-75 GHz VDI Standard Downconverter with 9VDC supply Keysight	SA Extension WR15	SAX 381	Apr. 25, 2023	Apr. 24, 2024
N9029AV10-DC9 - 75-110 GHz VDI Standard Downconverter with 9VDC supply Keysight	SA Extension WR10	SAX 378	Apr. 25, 2023	Apr. 24, 2024
N9029AV06-DC9 - 110-170 GHz VDI Standard Downconverter with 9VDC supply Keysight	N9029AV06	SAX 723	Apr. 25, 2023	Apr. 24, 2024
N9029AV06-DC9 - 170-220 GHz VDI Standard Downconverter with 9VDC supply Keysight	N9029AV05	SAX722	Apr. 25, 2023	Apr. 24, 2024
N9029AV06-DC9 – 220-325 GHz VDI Standard Downconverter with 9VDC supply Keysight	N9029AV03	SAX721	Apr. 25, 2023	Apr. 24, 2024
Millimeter-Wave Signal Generator Frequency Extension Module (50~75 GHz) Keysight	E8257DV15	SGX 648	Apr. 25, 2023	Apr. 24, 2024
Millimeter-Wave Signal Generator Frequency Extension Module (75~110 GHz) Keysight	E8257DV10	SGX 647	Apr. 25, 2023	Apr. 24, 2024
Millimeter-Wave Signal Generator Frequency Extension Module (110~170 GHz) Keysight	E8257DV06	SGX 645	Apr. 25, 2023	Apr. 24, 2024
Millimeter-Wave Signal Generator Frequency Extension Module (140~220 GHz)	E8257DV05	SGX 644	Apr. 25, 2023	Apr. 24, 2024

Description & Manufacturer	Model No.	Serial No.	Cal. Date	Cal. Due
Millimeter-Wave Signal Generator Frequency Extension Module (220~325 GHz)	E8257DV03	SGX 643	Apr. 25, 2023	Apr. 24, 2024
PSG analog signal generator Keysight	E8257D	MY53401987	Jun. 14, 2023	Jun. 13, 2024
Antenna Tower & Turn Table CT	NA	NA	NA	NA
Power Sensor (50~120 GHz) Keysight	U8489A	US59290810	Apr. 25, 2023	Apr. 24, 2024
Power Meter (110~325 GHz) VDI	PM5B	571V	Apr. 25, 2023	Apr. 24, 2024

Note:

1. The calibration interval of the above test instruments is 12 months and the calibrations are traceable to NML/ROC and NIST/USA.
2. The test was performed in WM Chamber 7.
3. Test date: 2024/1/31

4.1.3 Test Procedures

For Radiated emission: Below 30 MHz

- a. The EUT was placed on the top of a rotating table 0.8 meters above the ground at a 3 meter chamber room. The table was rotated 360 degrees to determine the position of the highest radiation.
- b. The EUT was set 3 meters away from the interference-receiving antenna, which was mounted on the top of a variable-height antenna tower.
- c. Parallel, perpendicular, and ground-parallel orientations of the antenna are set to make the measurement.
- d. For each suspected emission, the EUT was arranged to its worst case and the rotatable table was turned from 0 degrees to 360 degrees to find the maximum reading.
- e. The test-receiver system was set to Quasi-Peak Detect Function and Specified Bandwidth with Maximum Hold Mode.

NOTE:

1. The resolution bandwidth and video bandwidth of test receiver/spectrum analyzer is 9kHz at frequency below 30MHz.

For Radiated emission: 30 MHz ~ 40GHz

- a. The EUT was placed on the top of a rotating table 0.8 meters (for 30MHz ~ 1GHz) / 1.5 meters (for above 1GHz) above the ground at 3 meter chamber room for test. The table was rotated 360 degrees to determine the position of the highest radiation.
- b. The EUT was set 3 meters away from the interference-receiving antenna, which was mounted on the top of a variable-height antenna tower.
- c. The height of antenna is varied from one meter to four meters above the ground to determine the maximum value of the field strength. Both horizontal and vertical polarizations of the antenna are set to make the measurement.
- d. For each suspected emission, the EUT was arranged to its worst case and then the antenna was tuned to heights from 1 meter to 4 meters and the rotatable table was turned from 0 degrees to 360 degrees to find the maximum reading.
- e. The test-receiver system was set to quasi-peak detect function and specified bandwidth with maximum hold mode when the test frequency is below 1 GHz.
- f. The test-receiver system was set to peak and average detect function and specified bandwidth with maximum hold mode when the test frequency is above 1 GHz. If the peak reading value also meets average limit, measurement with the average detector is unnecessary.

Note:

1. The resolution bandwidth and video bandwidth of test receiver/spectrum analyzer is 120kHz for Quasi-peak detection (QP) at frequency below 1GHz.
2. The resolution bandwidth is 1MHz and video bandwidth of test receiver/spectrum analyzer is 3MHz for Peak detection (PK) at frequency from 1GHz to 40GHz.
3. The resolution bandwidth is 1MHz and video bandwidth of test receiver/spectrum analyzer is 3MHz for Average detection (AV) at frequency from 1GHz to 40GHz.
4. All modes of operation were investigated and the worst-case emissions are reported.

For Radiated emission: Above 40GHz

External mixers are utilized.

- a. The EUT was placed on the top of a rotating table 1.5 meters above the ground at a 3 meters chamber room. The table was rotated 360 degrees to determine the position of the highest radiation.
- b. The distance at which limits are typically specified is 3 meter; however, closer measurement distances may be utilized.
- c. Begin handheld measurements with the test antenna (horn) at a distance of 1 meter from the EUT, in a horizontally polarized position. Slowly adjust its position, entirely covering the plane 1 meter from the EUT.
- d. Repeat (b) with the horn in a vertically polarized position.
- e. If the emission cannot be detected at 1 meter, reduce the RBW in order to increase system sensitivity. Note the value. If the emission still cannot be detected, move the horn closer to the EUT, noting the distance at which a measurement is made.
- f. Note the maximum level indicated on the Spectrum Analyzer.
- g. Based on the distance at which the measurement was made and the calculated distance to the edge of the far field, determine the appropriate distance attenuation factor. Apply this factor to the calculated field strength in order to determine the equivalent field strength at the distance at which the regulatory limit is specified. Compare to the appropriate limits
- h. Repeat (a) - (f) for every emission that must be measured, up through the required frequency range of investigation

NOTE:

1. The maximum power (EIRP) for average measured, based on measurements employing a power averaging detector with a 1 MHz resolution bandwidth (RBW) and integrated over the full 99% occupied bandwidth (OBW) to obtain the data necessary to demonstrate compliance to the 50 dBm limit.
2. The maximum peak power (EIRP) for peak measured shall not exceed 55 dBm, based on measurements employing a peak detector with a 1 MHz RBW.
3. The resolution bandwidth is 1MHz and video bandwidth of test receiver/spectrum analyzer is 3MHz for RMS detection at frequency above 40GHz.

4.1.4 Deviation from Test Standard

No deviation.

4.1.5 Test Setup

For Radiated emission below 30MHz

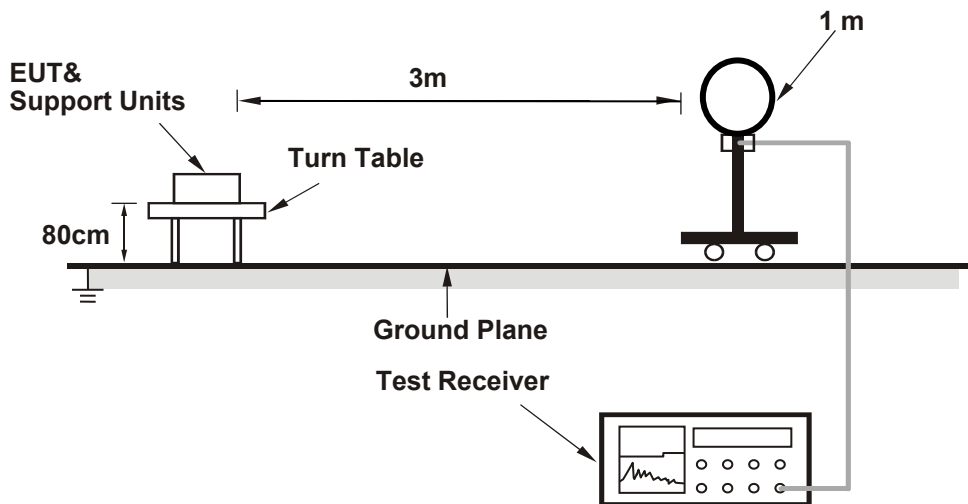

For Radiated emission 30MHz to 1GHz

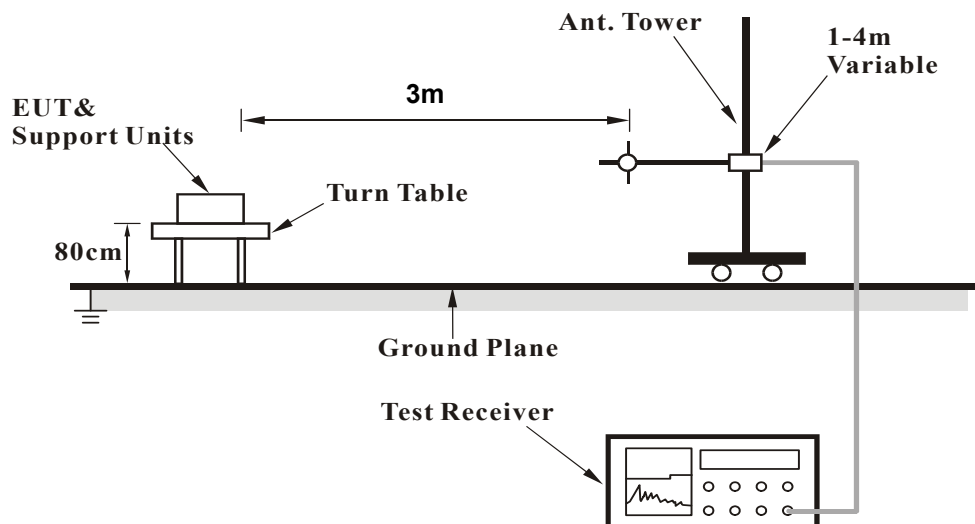

For Radiated emission 1GHz to 50GHz

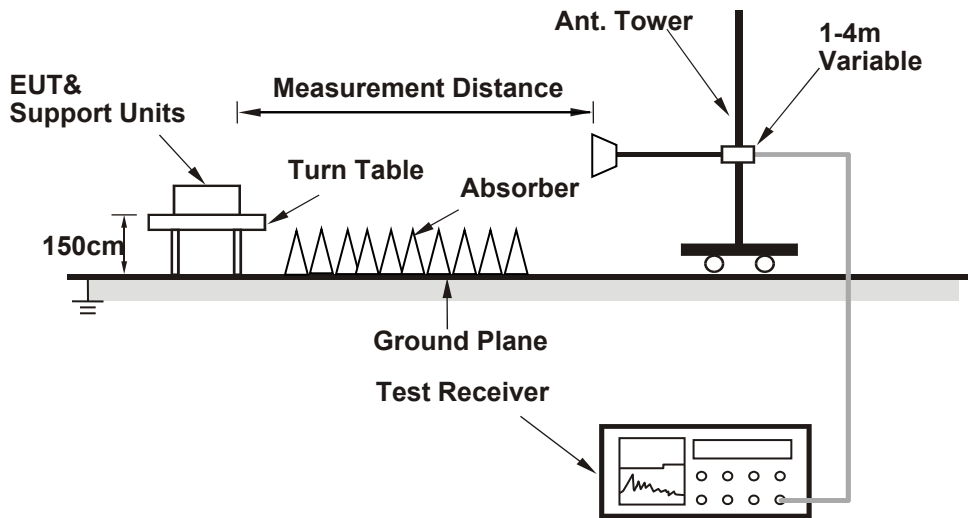

For Radiated emission above 50GHz

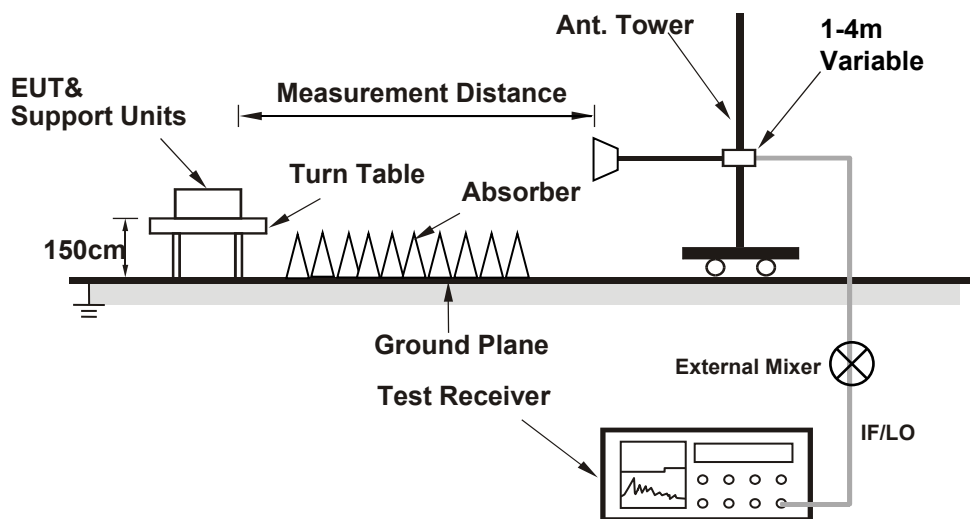

For the actual test configuration, please refer to the attached file (Test Setup Photo).

4.1.6 EUT Operating Conditions

Set the EUT under transmission condition continuously at specific channel frequency.

4.1.7 Test Results

CH 1 : 78.82 GHz

Above 1GHz Data

Frequency Range	1GHz ~ 18GHz	Detector Function	Peak (PK) Average (AV)
-----------------	--------------	-------------------	---------------------------

Antenna Polarity & Test Distance : Horizontal at 3 m								
No	Frequency (MHz)	Emission Level (dBuV/m)	Limit (dBuV/m)	Margin (dB)	Antenna Height (m)	Table Angle (Degree)	Raw Value (dBuV)	Correction Factor (dB/m)
1	17932.00	53.9 PK	74.0	-20.1	1.55 H	50	54.0	-0.1
2	17932.00	41.5 AV	54.0	-12.5	1.55 H	50	41.6	-0.1
Antenna Polarity & Test Distance : Vertical at 3 m								
No	Frequency (MHz)	Emission Level (dBuV/m)	Limit (dBuV/m)	Margin (dB)	Antenna Height (m)	Table Angle (Degree)	Raw Value (dBuV)	Correction Factor (dB/m)
1	17932.00	53.5 PK	74.0	-20.5	1.42 V	45	53.6	-0.1
2	17932.00	41.3 AV	54.0	-12.7	1.42 V	45	41.4	-0.1

Remarks:

1. Emission Level(dBuV/m) = Raw Value(dBuV) + Correction Factor(dB/m)
2. Correction Factor(dB/m) = Antenna Factor(dB/m) + Cable Factor(dB) – Pre-Amplifier Factor(dB)
3. Margin value = Emission Level – Limit value
4. The other emission levels were very low against the limit.
5. " # ": The radiated frequency is out of the restricted band.

Frequency Range	18GHz ~ 40GHz	Detector Function	Peak (PK) Average (AV)
------------------------	---------------	--------------------------	---------------------------

Antenna Polarity : Horizontal								
No	Frequency (MHz)	Emission Level (dBuV/m)	Limit (dBuV/m)	Margin (dB)	Antenna Height (m)	Table Angle (Degree)	Raw Value (dBuV)	Correction Factor (dB/m)
1	38086.00	57.9 PK	74.0	-16.1	1.55 H	211	58.3	-0.4
2	38086.00	46.9 AV	54.0	-7.1	1.55 H	211	47.3	-0.4
Antenna Polarity : Vertical								
No	Frequency (MHz)	Emission Level (dBuV/m)	Limit (dBuV/m)	Margin (dB)	Antenna Height (m)	Table Angle (Degree)	Raw Value (dBuV)	Correction Factor (dB/m)
1	38086.00	57.5 PK	74.0	-16.5	1.37 V	155	57.9	-0.4
2	38086.00	46.7 AV	54.0	-7.3	1.37 V	155	47.1	-0.4

Remarks:

1. Emission Level(dBuV/m) = Raw Value(dBuV) + Correction Factor(dB/m)
2. Correction Factor(dB/m) = Antenna Factor(dB/m) + Cable Factor(dB) – Pre-Amplifier Factor(dB)
3. Margin value = Emission Level – Limit value
4. The other emission levels were very low against the limit.
5. " # ": The radiated frequency is out of the restricted band.

Frequency Range	76GHz ~ 81GHz	Detector Function	Peak (PK) Average (AV)
-----------------	---------------	-------------------	---------------------------

Antenna Polarity & Test Distance : Horizontal

NO.	Frequency (GHz)	SA Value (dbm)	Gain of test Antenna (dBi)	E _{Meas} (dBμV/m)	EIRP Level (dBm)	EIRP Limit (dBm)	PASS/FAIL
1	78.82	-25.77	20.00	129.42	24.72 PK	55.00	PASS
2	78.82	-64.38	20.00	90.81	-13.89 AV	50.00	PASS

Antenna Polarity & Test Distance : Vertical

NO.	Frequency (GHz)	SA Value (dbm)	Gain of test Antenna (dBi)	E _{Meas} (dBμV/m)	EIRP Level (dBm)	EIRP Limit (dBm)	PASS/FAIL
1	78.82	-38.17	20.00	117.02	12.32 PK	55.00	PASS
2	78.82	-75.41	20.00	79.78	-24.92 AV	50.00	PASS

Spectrum Plot of Worst Value

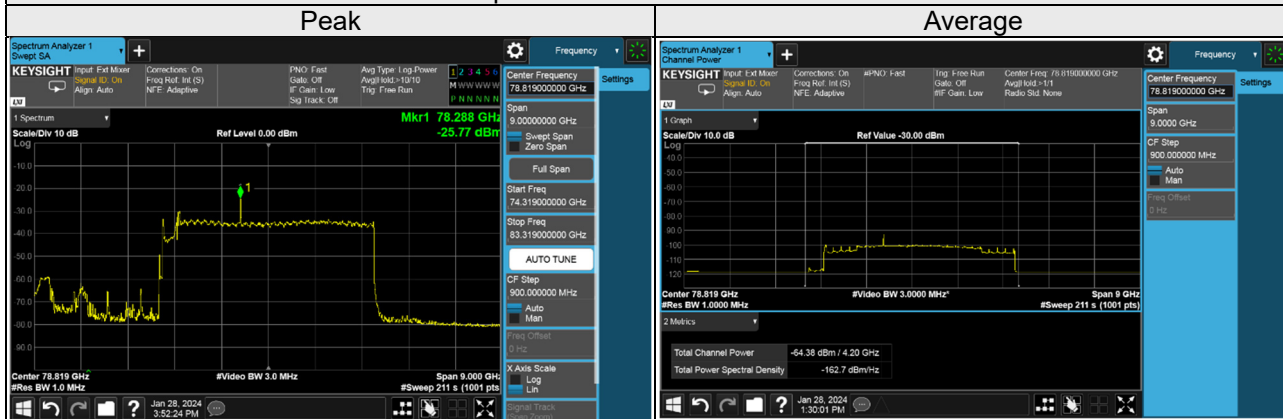

REMARKS:

1. The measured power level is converted to EIRP using the equation:

Follow ANSI 63.10 section 9.4 Equations to calculate and extrapolate field strength

$$E_{\text{Meas}} \text{ (dB}\mu\text{V/m)} = 126.8 - 20\log(\lambda) + P - G$$

where:

E_{Meas} is the field strength of the emission at the measurement distance, in dB μ V/m

P is the power measured at the output of the test antenna, in dBm

λ is the wavelength of the emission under investigation [300/fMHz], in m

G is the gain of the test antenna, in dBi

Follow ANSI 63.10 section 9.5 Equations to calculate EIRP

$$\text{EIRP Level (dBm/MHz)} = E_{\text{Meas}} \text{ (dB}\mu\text{V/m)} + 20 * \log(d_{\text{Meas}}) - 104.7$$

where:

EIRP is the equivalent isotropically radiated power, in dBm

E_{Meas} is the field strength of the emission at the measurement distance, in dB μ V/m

d_{Meas} is the measurement distance, in m

Measurements made at 1 meter distance.

2. The far-field boundary is given in ANSI 63.10 as:

$$R \text{ far field} = (2 * L^2) / \lambda$$

L is the Largest Antenna Dimension of either the EUT antenna or measurement antenna, including the reflector

λ is the wavelength

FREQUENCY (GHz)	L (m)	Lambda (m)	R (Far Field) (m)
78.82	0.022627417	0.00381	0.269

Frequency Range	40GHz ~ 231GHz	Detector Function	RMS (AV)
-----------------	----------------	-------------------	----------

Antenna Polarity : Horizontal								
NO.	Frequency (GHz)	SA Value (dBm)	Gain of test Antenna (dBi)	E _{Meas} (dBμV/m)	EIRP Level (dBm/MHz)	Power Density (pW/cm ²)	Power Density Limit (pW/cm ²)	PASS/FAIL
1	48.25	-107.87	20.30	42.76	-52.40	0.01	600.00	PASS
2	56.92	-105.03	19.90	47.43	-47.72	0.01	600.00	PASS
3	75.88	-95.60	20.00	59.26	-35.90	0.23	600.00	PASS
4	109.47	-84.17	20.00	73.87	-21.28	6.58	600.00	PASS
5	169.42	-106.69	20.50	54.65	-40.51	0.08	600.00	PASS
6	170.89	-89.50	21.32	71.09	-24.07	3.47	600.00	PASS
7	221.00	-91.67	21.52	70.96	-24.20	3.36	1000.00	PASS
Antenna Polarity : Vertical								
NO.	Frequency (GHz)	SA Value (dBm)	Gain of test Antenna (dBi)	E _{Meas} (dBμV/m)	EIRP Level (dBm/MHz)	Power Density (pW/cm ²)	Power Density Limit (pW/cm ²)	PASS/FAIL
1	48.38	-107.91	20.30	42.74	-52.42	0.01	600.00	PASS
2	56.91	-105.14	19.90	47.32	-47.84	0.01	600.00	PASS
3	75.83	-95.66	20.00	59.19	-35.96	0.22	600.00	PASS
4	109.72	-84.25	20.00	73.81	-21.34	6.49	600.00	PASS
5	169.55	-106.70	20.50	54.64	-40.51	0.08	600.00	PASS
6	170.45	-89.52	21.32	71.05	-24.11	3.43	600.00	PASS
7	220.99	-91.77	21.52	70.86	-24.30	3.28	1000.00	PASS

REMARKS:

1. The measured power level is converted to EIRP using the equation:

Follow ANSI 63.10 section 9.4 Equations to calculate and extrapolate field strength

$$E_{Meas} \text{ (dB}\mu\text{V/m)} = 126.8 - 20\log(\lambda) + P - G$$

where:

E_{Meas} is the field strength of the emission at the measurement distance, in dBμV/m

P is the power measured at the output of the test antenna, in dBm

λ is the wavelength of the emission under investigation [300/fMHz], in m

G is the gain of the test antenna, in dBi

Follow ANSI 63.10 section 9.5 Equations to calculate EIRP

$$\text{EIRP Level (dBm/MHz)} = E_{Meas} \text{ (dB}\mu\text{V/m)} + 20 \cdot \log(d_{Meas}) - 104.7$$

E_{Meas} is the field strength of the emission at the measurement distance, in dBμV/m

d_{Meas} is the measurement distance, in m

Measurements made at 3 meter distance.

2. Power density formula as follows

Follow ANSI 63.10 section 9.6 Equations to calculate power density

$$PD = \text{EIRP}_{\text{Linear}} / 4 \pi d^2$$

PD is the power density at the distance specified by the limit, in W/m²

$EIRP_{Linear}$ is the equivalent isotropically radiated power, in watts

d is the 3m distance.

3. The far-field boundary is given in ANSI 63.10 as:

$$R \text{ far field} = (2 * L^2) / \lambda$$

L is the Largest Antenna Dimension of measurement antenna, including the reflector

λ is the wavelength

Frequency (GHz)	L (m)	Lambda (m)	R (Far Field) (m)
40	0.03	0.0075	0.240
50	0.03	0.0060	0.300

Frequency (GHz)	L (m)	Lambda (m)	R (Far Field) (m)
50	0.025	0.0060	0.208
75	0.025	0.0040	0.313

Frequency (GHz)	L (m)	Lambda (m)	R (Far Field) (m)
75	0.018	0.0040	0.162
110	0.018	0.0027	0.238

Frequency (GHz)	L (m)	Lambda (m)	R (Far Field) (m)
110	0.012	0.0027	0.106
170	0.012	0.0018	0.163

Frequency (GHz)	L (m)	Lambda (m)	R (Far Field) (m)
170	0.008	0.0018	0.073
260	0.008	0.0012	0.111

Below 1GHz Data

FREQUENCY RANGE	9kHz ~ 1GHz	DETECTOR FUNCTION	Quasi-Peak (QP)
------------------------	-------------	--------------------------	-----------------

Antenna Polarity & Test Distance : Horizontal at 3 m

No	Frequency (MHz)	Emission Level (dBuV/m)	Limit (dBuV/m)	Margin (dB)	Antenna Height (m)	Table Angle (Degree)	Raw Value (dBuV)	Correction Factor (dB/m)
1	54.25	27.0 QP	40.0	-13.0	2.00 H	237	40.4	-13.4
2	161.92	27.0 QP	43.5	-16.5	1.01 H	2	40.0	-13.0
3	326.82	34.7 QP	46.0	-11.3	1.01 H	19	46.3	-11.6
4	462.62	39.2 QP	46.0	-6.8	2.00 H	175	47.5	-8.3
5	732.28	38.2 QP	46.0	-7.8	1.51 H	124	41.5	-3.3
6	926.28	40.5 QP	46.0	-5.5	1.51 H	201	41.0	-0.5

Remarks:

1. Emission Level(dBuV/m) = Raw Value(dBuV) + Correction Factor(dB/m)
2. Correction Factor(dB/m) = Antenna Factor(dB/m) + Cable Factor(dB) – Pre-Amplifier Factor(dB)
3. Margin value = Emission Level – Limit value
4. The other emission levels were very low against the limit of frequency range 30MHz~1000MHz.
5. The frequency range 9 kHz ~ 30 MHz: all emissions are more than 20 dB below the limit, therefore do not be recorded in this report.

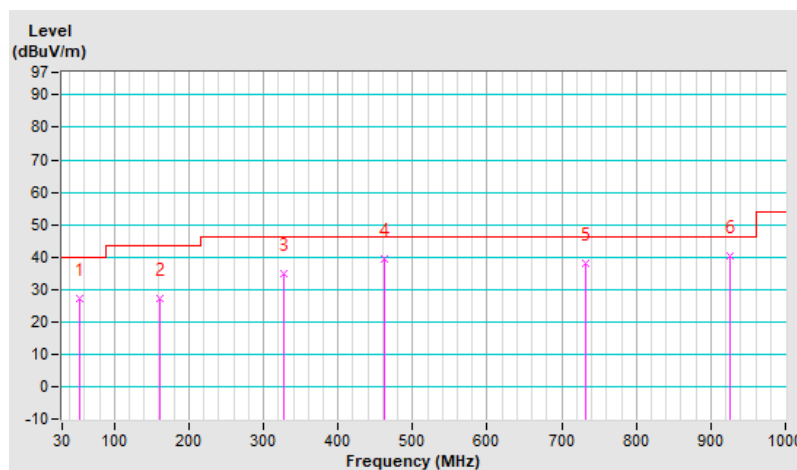

FREQUENCY RANGE	9kHz ~ 1GHz	DETECTOR FUNCTION	Quasi-Peak (QP)
------------------------	-------------	--------------------------	-----------------

Antenna Polarity & Test Distance : Vertical at 3 m								
No	Frequency (MHz)	Emission Level (dBuV/m)	Limit (dBuV/m)	Margin (dB)	Antenna Height (m)	Table Angle (Degree)	Raw Value (dBuV)	Correction Factor (dB/m)
1	48.43	32.1 QP	40.0	-7.9	1.00 V	273	45.2	-13.1
2	74.62	28.5 QP	40.0	-11.5	1.00 V	55	45.1	-16.6
3	250.19	29.3 QP	46.0	-16.7	1.99 V	18	43.5	-14.2
4	450.98	34.3 QP	46.0	-11.7	1.99 V	285	42.7	-8.4
5	704.15	37.1 QP	46.0	-8.9	1.49 V	2	40.8	-3.7
6	783.69	41.8 QP	46.0	-4.2	1.00 V	31	44.1	-2.3

Remarks:

1. Emission Level(dBuV/m) = Raw Value(dBuV) + Correction Factor(dB/m)
2. Correction Factor(dB/m) = Antenna Factor(dB/m) + Cable Factor(dB) – Pre-Amplifier Factor(dB)
3. Margin value = Emission Level – Limit value
4. The other emission levels were very low against the limit of frequency range 30MHz~1000MHz.
5. The frequency range 9 kHz ~ 30 MHz: all emissions are more than 20 dB below the limit, therefore do not be recorded in this report.

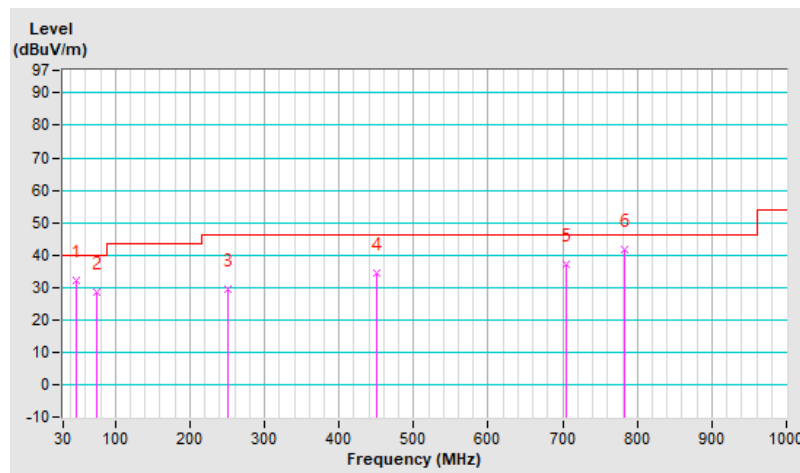

CH 2 : 78.98 GHz

Above 1GHz Data

Frequency Range	1GHz ~ 18GHz	Detector Function	Peak (PK) Average (AV)
------------------------	--------------	--------------------------	---------------------------

Antenna Polarity & Test Distance : Horizontal at 3 m								
No	Frequency (MHz)	Emission Level (dBuV/m)	Limit (dBuV/m)	Margin (dB)	Antenna Height (m)	Table Angle (Degree)	Raw Value (dBuV)	Correction Factor (dB/m)
1	17864.00	53.4 PK	74.0	-20.6	1.47 H	39	53.7	-0.3
2	17864.00	41.2 AV	54.0	-12.8	1.47 H	39	41.5	-0.3
Antenna Polarity & Test Distance : Vertical at 3 m								
No	Frequency (MHz)	Emission Level (dBuV/m)	Limit (dBuV/m)	Margin (dB)	Antenna Height (m)	Table Angle (Degree)	Raw Value (dBuV)	Correction Factor (dB/m)
1	17864.00	53.1 PK	74.0	-20.9	1.47 V	39	53.4	-0.3
2	17864.00	41.0 AV	54.0	-13.0	1.47 V	39	41.3	-0.3

Remarks:

1. Emission Level(dBuV/m) = Raw Value(dBuV) + Correction Factor(dB/m)
2. Correction Factor(dB/m) = Antenna Factor(dB/m) + Cable Factor(dB) – Pre-Amplifier Factor(dB)
3. Margin value = Emission Level – Limit value
4. The other emission levels were very low against the limit.
5. " # ": The radiated frequency is out of the restricted band.

Frequency Range	18GHz ~ 40GHz	Detector Function	Peak (PK) Average (AV)
------------------------	---------------	--------------------------	---------------------------

Antenna Polarity : Horizontal								
No	Frequency (MHz)	Emission Level (dBuV/m)	Limit (dBuV/m)	Margin (dB)	Antenna Height (m)	Table Angle (Degree)	Raw Value (dBuV)	Correction Factor (dB/m)
1	39648.00	58.7 PK	74.0	-15.3	1.69 H	311	58.8	-0.1
2	39648.00	46.9 AV	54.0	-7.1	1.69 H	311	47.0	-0.1

Antenna Polarity : Vertical								
No	Frequency (MHz)	Emission Level (dBuV/m)	Limit (dBuV/m)	Margin (dB)	Antenna Height (m)	Table Angle (Degree)	Raw Value (dBuV)	Correction Factor (dB/m)
1	39648.00	58.4 PK	74.0	-15.6	1.33 V	244	58.5	-0.1
2	39648.00	46.7 AV	54.0	-7.3	1.33 V	244	46.8	-0.1

Remarks:

1. Emission Level(dBuV/m) = Raw Value(dBuV) + Correction Factor(dB/m)
2. Correction Factor(dB/m) = Antenna Factor(dB/m) + Cable Factor(dB) – Pre-Amplifier Factor(dB)
3. Margin value = Emission Level – Limit value
4. The other emission levels were very low against the limit.
5. " # ": The radiated frequency is out of the restricted band.

Frequency Range	76GHz ~ 81GHz	Detector Function	Peak (PK) Average (AV)
-----------------	---------------	-------------------	---------------------------

Antenna Polarity & Test Distance : Horizontal

NO.	Frequency (GHz)	SA Value (dbm)	Gain of test Antenna (dBi)	E _{Meas} (dBμV/m)	EIRP Level (dBm)	EIRP Limit (dBm)	PASS/FAIL
1	78.98	-26.37	20.00	128.84	24.14 PK	55.00	PASS
2	78.98	-65.54	20.00	89.67	-15.03 AV	50.00	PASS

Antenna Polarity & Test Distance : Vertical

NO.	Frequency (GHz)	SA Value (dbm)	Gain of test Antenna (dBi)	E _{Meas} (dBμV/m)	EIRP Level (dBm)	EIRP Limit (dBm)	PASS/FAIL
1	78.98	-38.76	20.00	116.45	11.75 PK	55.00	PASS
2	78.98	-78.03	20.00	77.18	-27.52 AV	50.00	PASS

Spectrum Plot of Worst Value

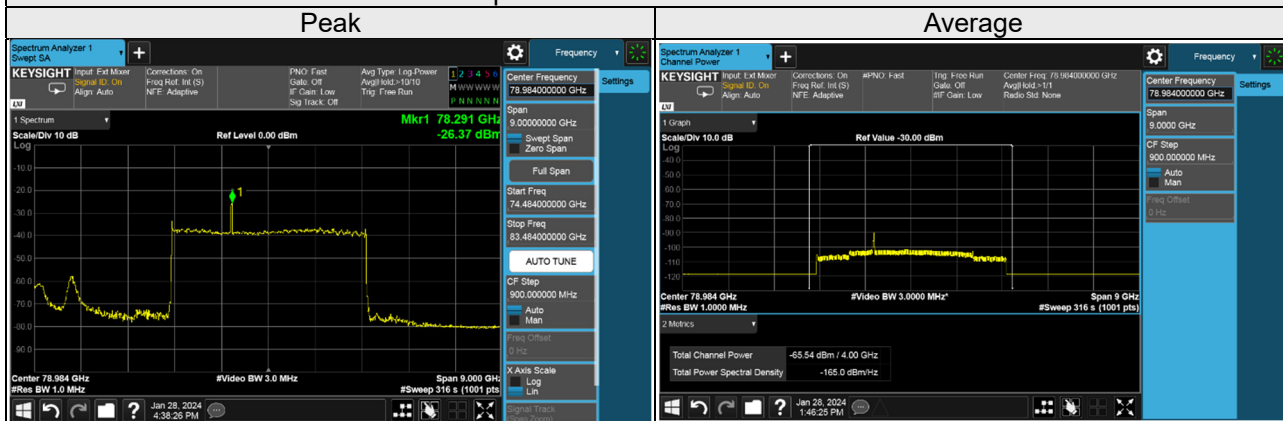

REMARKS:

1. The measured power level is converted to EIRP using the equation:

Follow ANSI 63.10 section 9.4 Equations to calculate and extrapolate field strength

$$E_{\text{Meas}} \text{ (dB}\mu\text{V/m)} = 126.8 - 20\log(\lambda) + P - G$$

where:

E_{Meas} is the field strength of the emission at the measurement distance, in dB μ V/m

P is the power measured at the output of the test antenna, in dBm

λ is the wavelength of the emission under investigation [300/fMHz], in m

G is the gain of the test antenna, in dBi

Follow ANSI 63.10 section 9.5 Equations to calculate EIRP

$$\text{EIRP Level (dBm/MHz)} = E_{\text{Meas}} \text{ (dB}\mu\text{V/m)} + 20 * \log(d_{\text{Meas}}) - 104.7$$

where:

EIRP is the equivalent isotropically radiated power, in dBm

E_{Meas} is the field strength of the emission at the measurement distance, in dB μ V/m

d_{Meas} is the measurement distance, in m

Measurements made at 1 meter distance.

2. The far-field boundary is given in ANSI 63.10 as:

$$R \text{ far field} = (2 * L^2) / \lambda$$

L is the Largest Antenna Dimension of either the EUT antenna or measurement antenna, including the reflector

λ is the wavelength

FREQUENCY (GHz)	L (m)	Lambda (m)	R (Far Field) (m)
78.98	0.022627417	0.0038	0.269

Frequency Range	40GHz ~ 231GHz	Detector Function	RMS (AV)
-----------------	----------------	-------------------	----------

Antenna Polarity : Horizontal								
NO.	Frequency (GHz)	SA Value (dBm)	Gain of test Antenna (dBi)	E _{Meas} (dB μ V/m)	EIRP Level (dBm/MHz)	Power Density (pW/cm ²)	Power Density Limit (pW/cm ²)	PASS/FAIL
1	48.19	-107.84	20.30	42.78	-52.38	0.01	600.00	PASS
2	57.23	-105.15	19.90	47.36	-47.80	0.01	600.00	PASS
3	75.94	-95.60	20.00	59.27	-35.89	0.23	600.00	PASS
4	109.55	-84.14	20.00	73.91	-21.25	6.63	600.00	PASS
5	169.32	-106.72	20.50	54.61	-40.55	0.08	600.00	PASS
6	171.08	-89.50	21.32	71.10	-24.06	3.48	600.00	PASS
7	220.99	-91.64	21.52	70.99	-24.17	3.38	1000.00	PASS
Antenna Polarity : Vertical								
NO.	Frequency (GHz)	SA Value (dBm)	Gain of test Antenna (dBi)	E _{Meas} (dB μ V/m)	EIRP Level (dBm/MHz)	Power Density (pW/cm ²)	Power Density Limit (pW/cm ²)	PASS/FAIL
1	48.46	-107.90	20.30	42.77	-52.39	0.01	600.00	PASS
2	57.34	-105.17	19.90	47.36	-47.80	0.01	600.00	PASS
3	75.91	-95.61	20.00	59.25	-35.90	0.23	600.00	PASS
4	109.88	-84.28	20.00	73.80	-21.36	6.46	600.00	PASS
5	169.74	-106.74	20.50	54.61	-40.54	0.08	600.00	PASS
6	170.52	-89.77	21.32	70.80	-24.35	3.24	600.00	PASS
7	221.00	-91.75	21.52	70.88	-24.28	3.30	1000.00	PASS

REMARKS:

1. The measured power level is converted to EIRP using the equation:

Follow ANSI 63.10 section 9.4 Equations to calculate and extrapolate field strength

$$E_{Meas} \text{ (dB}\mu\text{V/m)} = 126.8 - 20\log(\lambda) + P - G$$

where:

E_{Meas} is the field strength of the emission at the measurement distance, in dB μ V/m

P is the power measured at the output of the test antenna, in dBm

λ is the wavelength of the emission under investigation [300/fMHz], in m

G is the gain of the test antenna, in dBi

Follow ANSI 63.10 section 9.5 Equations to calculate EIRP

$$\text{EIRP Level (dBm/MHz)} = E_{Meas} \text{ (dB}\mu\text{V/m)} + 20 \cdot \log(d_{Meas}) - 104.7$$

E_{Meas} is the field strength of the emission at the measurement distance, in dB μ V/m

d_{Meas} is the measurement distance, in m

Measurements made at 3 meter distance.

2. Power density formula as follows

Follow ANSI 63.10 section 9.6 Equations to calculate power density

$$PD = \text{EIRP}_{\text{Linear}} / 4 \pi d^2$$

PD is the power density at the distance specified by the limit, in W/m²

$EIRP_{Linear}$ is the equivalent isotropically radiated power, in watts

d is the 3m distance.

3. The far-field boundary is given in ANSI 63.10 as:

$$R \text{ far field} = (2 * L^2) / \lambda$$

L is the Largest Antenna Dimension of measurement antenna, including the reflector

λ is the wavelength

Frequency (GHz)	L (m)	Lambda (m)	R (Far Field) (m)
40	0.03	0.0075	0.240
50	0.03	0.0060	0.300

Frequency (GHz)	L (m)	Lambda (m)	R (Far Field) (m)
50	0.025	0.0060	0.208
75	0.025	0.0040	0.313

Frequency (GHz)	L (m)	Lambda (m)	R (Far Field) (m)
75	0.018	0.0040	0.162
110	0.018	0.0027	0.238

Frequency (GHz)	L (m)	Lambda (m)	R (Far Field) (m)
110	0.012	0.0027	0.106
170	0.012	0.0018	0.163

Frequency (GHz)	L (m)	Lambda (m)	R (Far Field) (m)
170	0.008	0.0018	0.073
260	0.008	0.0012	0.111

Below 1GHz Data

FREQUENCY RANGE	9kHz ~ 1GHz	DETECTOR FUNCTION	Quasi-Peak (QP)
------------------------	-------------	--------------------------	-----------------

Antenna Polarity & Test Distance : Horizontal at 3 m								
No	Frequency (MHz)	Emission Level (dBuV/m)	Limit (dBuV/m)	Margin (dB)	Antenna Height (m)	Table Angle (Degree)	Raw Value (dBuV)	Correction Factor (dB/m)
1	52.31	26.8 QP	40.0	-13.2	1.00 H	275	39.9	-13.1
2	326.82	34.8 QP	46.0	-11.2	1.00 H	350	46.4	-11.6
3	443.22	38.5 QP	46.0	-7.5	1.99 H	18	47.2	-8.7
4	461.65	39.4 QP	46.0	-6.6	1.99 H	199	47.7	-8.3
5	795.33	40.3 QP	46.0	-5.7	1.49 H	130	42.7	-2.4
6	978.66	41.1 QP	54.0	-12.9	1.00 H	118	41.3	-0.2

Remarks:

1. Emission Level(dBuV/m) = Raw Value(dBuV) + Correction Factor(dB/m)
2. Correction Factor(dB/m) = Antenna Factor(dB/m) + Cable Factor(dB) – Pre-Amplifier Factor(dB)
3. Margin value = Emission Level – Limit value
4. The other emission levels were very low against the limit of frequency range 30MHz~1000MHz.
5. The frequency range 9 kHz ~ 30 MHz: all emissions are more than 20 dB below the limit, therefore do not be recorded in this report.

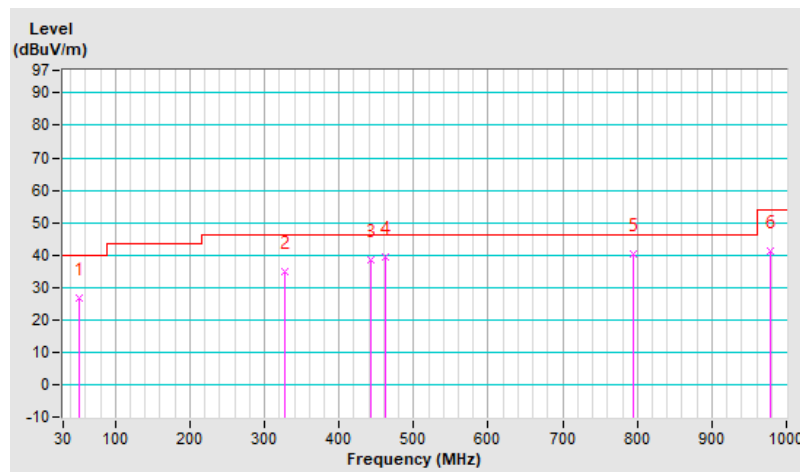

FREQUENCY RANGE	9kHz ~ 1GHz	DETECTOR FUNCTION	Quasi-Peak (QP)
------------------------	-------------	--------------------------	-----------------

Antenna Polarity & Test Distance : Vertical at 3 m								
No	Frequency (MHz)	Emission Level (dBuV/m)	Limit (dBuV/m)	Margin (dB)	Antenna Height (m)	Table Angle (Degree)	Raw Value (dBuV)	Correction Factor (dB/m)
1	48.43	34.6 QP	40.0	-5.4	1.01 V	305	47.7	-13.1
2	80.44	29.2 QP	40.0	-10.8	1.01 V	348	47.4	-18.2
3	454.86	34.4 QP	46.0	-11.6	1.50 V	275	42.7	-8.3
4	639.16	36.6 QP	46.0	-9.4	1.01 V	341	41.0	-4.4
5	856.44	39.6 QP	46.0	-6.4	2.00 V	2	41.2	-1.6
6	955.38	40.5 QP	46.0	-5.5	2.00 V	262	40.8	-0.3

Remarks:

1. Emission Level(dBuV/m) = Raw Value(dBuV) + Correction Factor(dB/m)
2. Correction Factor(dB/m) = Antenna Factor(dB/m) + Cable Factor(dB) – Pre-Amplifier Factor(dB)
3. Margin value = Emission Level – Limit value
4. The other emission levels were very low against the limit of frequency range 30MHz~1000MHz.
5. The frequency range 9 kHz ~ 30 MHz: all emissions are more than 20 dB below the limit, therefore do not be recorded in this report.

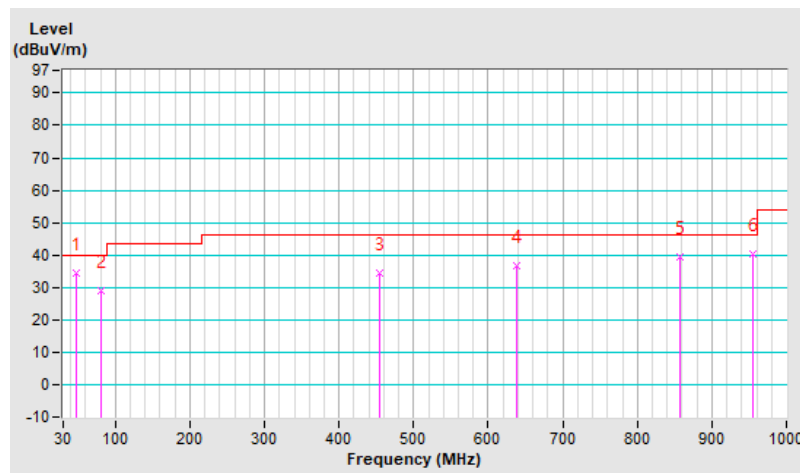

4.2 Modulation characteristics Measurement

The RF transceiver supports FMCW radar systems covering 77 to 81GHz. The FMCW generator will support a chirp waveform type as described by the below EDM chirp parameters.

Below EDM chirp parameters are used for short range and cargo measurements on B018:

Table 2-1 – EDM Chirp Parameter

Parameters	Default Chirp (us)	EDM Chirp (us)
Ta: Valley period (us)	59.93	9.20
Tb: Up slope period (us)	68.80	132.80
Tc: Peak period (us)	13.76	1.00
Td: Down slope period (us)	13.76	1.00
DFE decimation rate	6	12
Chirps per frame	32	2
FFT points	1024	1024

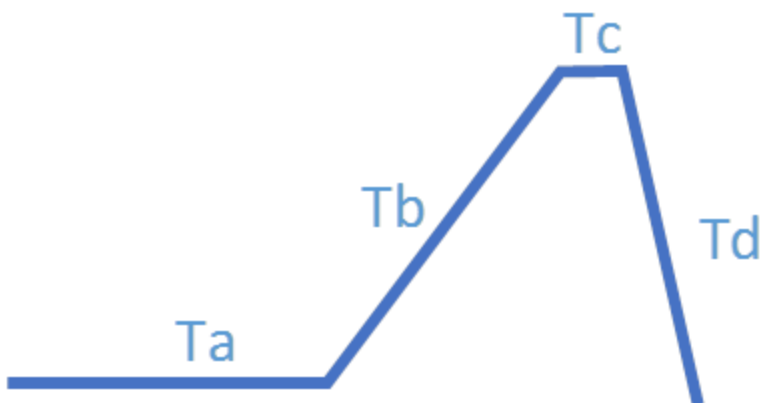
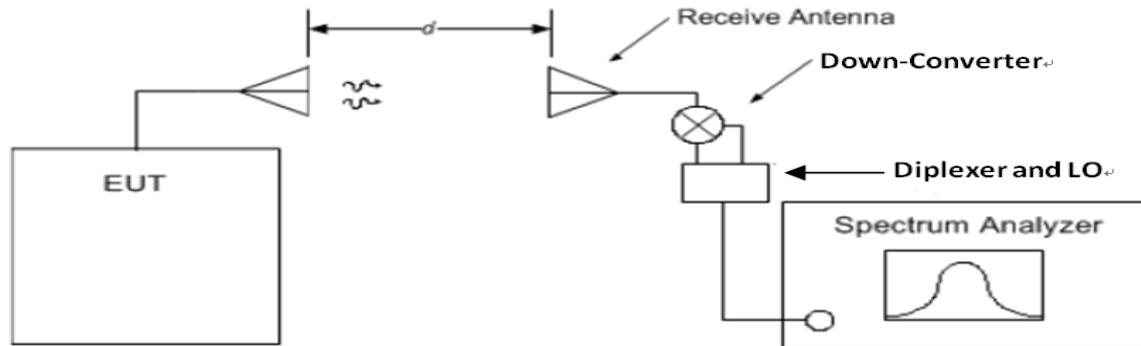

Figure 2-1 – Chirp Profile

4.3 Occupied Bandwidth Measurement

4.3.1 Test Setup



4.3.2 Test Instruments

Refer to section 4.1.2 to get information of above instrument.

4.3.3 Test Procedure

The bandwidth of the fundamental frequency was measured by spectrum analyzer with resolution bandwidth in the range of 1% to 5% of the anticipated emission bandwidth, and a video bandwidth at least 3x the resolution bandwidth and set the detector to PEAK. The width of a frequency band such that, below the lower and above the upper frequency limits, the mean powers emitted are each equal to a specified percentage 0.5% of the total mean power of a given emission.

4.3.4 Deviation from Test Standard

No deviation.

4.3.5 EUT Operating Conditions

Set the EUT under transmission condition continuously at specific channel frequency.

4.3.6 Test Results

Channel	Frequency (GHz)	Occupied Bandwidth (GHz)	Pass/Fail
1	78.82	4.0248	Pass

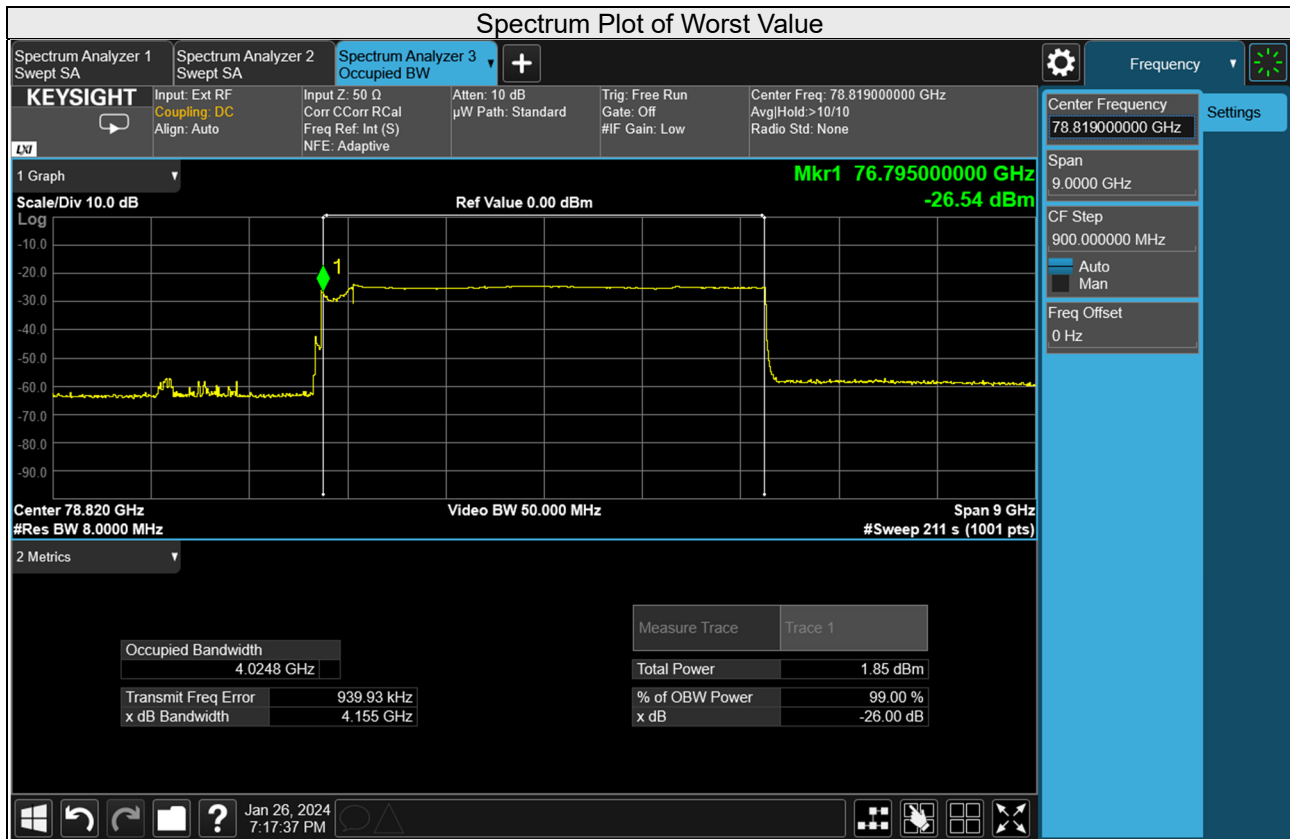

Channel	Frequency (GHz)	Occupied Bandwidth (GHz)	Pass/Fail
2	78.98	3.7145	Pass

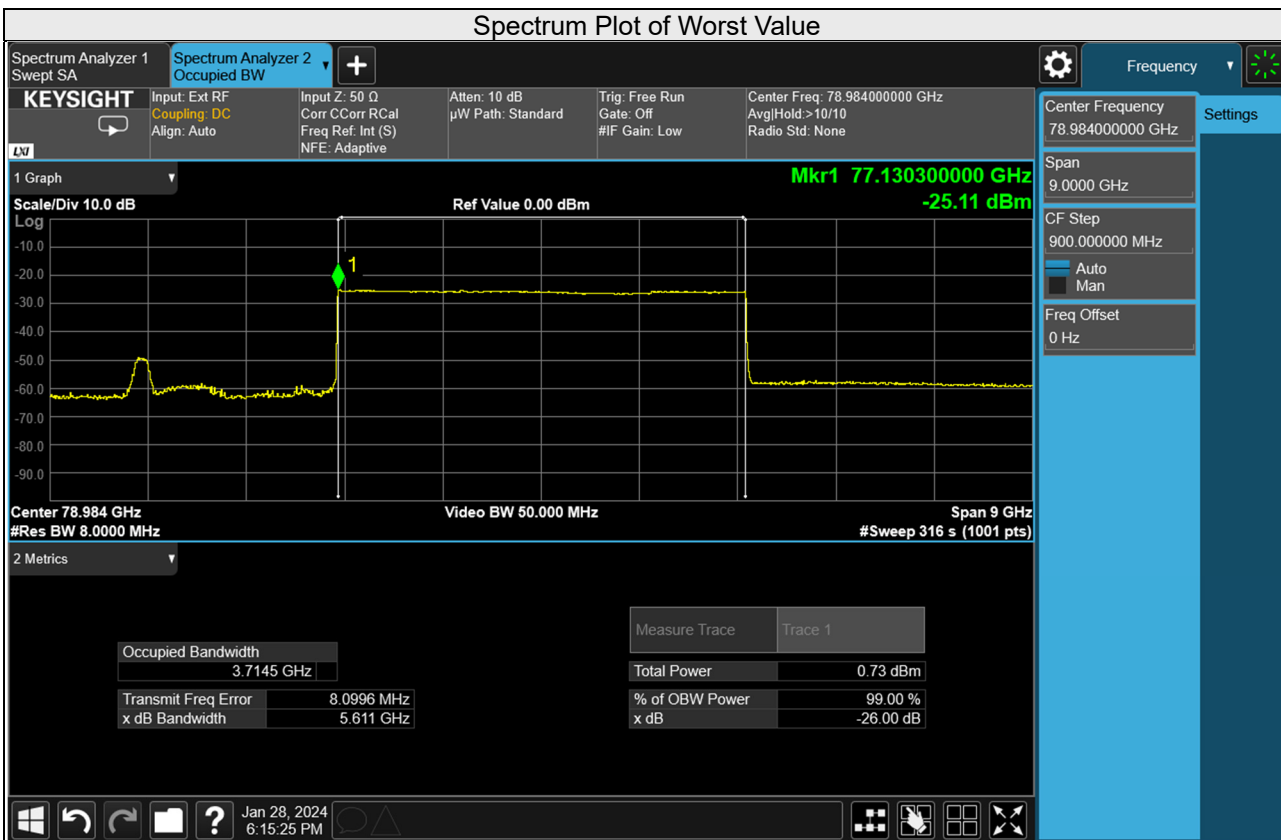

4.4 Frequency Stability Measurement

4.4.1 Limits of Frequency Stability Measurement

Fundamental emissions must be contained within the frequency bands specified in this section during all conditions of operation.

4.4.2 Test Instruments

Description & Manufacturer	Model No.	Serial No.	Cal. Date	Cal. Due
Spectrum Analyzer Agilent	N9010A	MY52220314	Dec. 24, 2023	Dec. 23, 2024
Spectrum Analyzer (50~110GHz) Keysight	V3050A	US60360159	Feb. 07, 2023	Feb. 06, 2024
Conical Horn Antenna (50~75GHz) Keysight	WR15CH-Conical	RCH015RL-2	Apr. 25, 2023	Apr. 24, 2024
DC Power Supply TOPWARD	6306A	727263	NA	NA
Temperature & Humidity Chamber TERCHY	HRM-120RF	931022	Dec. 19, 2023	Dec. 18, 2024

Note:

1. The calibration interval of the above test instruments is 12 months and the calibrations are traceable to NML/ROC and NIST/USA.
2. Tested date: 2024/2/2

4.4.3 Test Procedure

- a. The EUT was placed inside the environmental test chamber and powered by nominal DC voltage.
- b. Turn the EUT on and couple its output to a spectrum analyzer.
- c. Turn the EUT off and set the chamber to the highest temperature specified.
- d. Allow sufficient time (approximately 30 min) for the temperature of the chamber to stabilize, turn the EUT on and measure the operating frequency after 2, 5, and 10 minutes.
- e. Repeat step (d) with the temperature chamber set to the next desired temperature until measurements down to the lowest specified temperature have been completed.
- f. The test chamber was allowed to stabilize at +20 degree C for a minimum of 30 minutes. The supply voltage was then adjusted on the EUT from 85% to 115% and the frequency record.

4.4.4 Test Setup

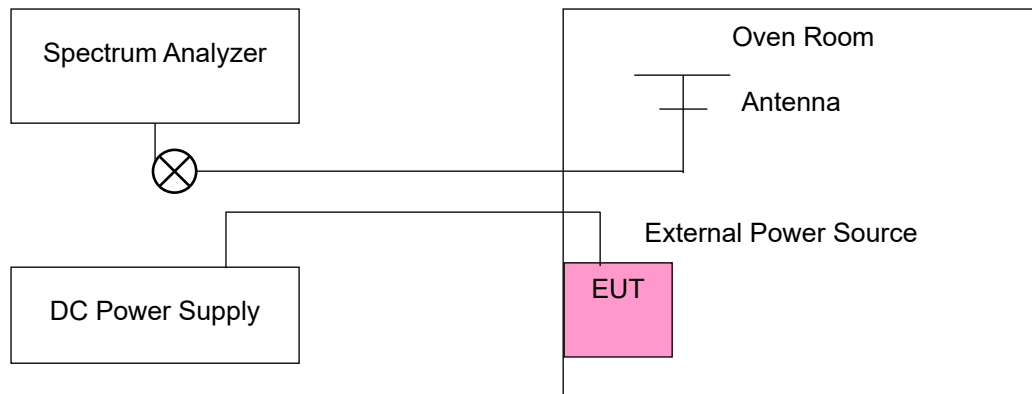

4.4.5 Test Results

Frequency Stability Versus Temperature									
Operating Frequency: 78819 MHz									
Temp. (°C)	Power Supply (Vdc)	0 Minute		2 Minutes		5 Minutes		10 Minutes	
		Measured Frequency (MHz)	Test Result	Measured Frequency (MHz)	Test Result	Measured Frequency (MHz)	Test Result	Measured Frequency (MHz)	Test Result
85	3.6	78819.091	Pass	78819.1485	Pass	78819.1547	Pass	78819.1151	Pass
80	3.6	78819.209	Pass	78819.2786	Pass	78819.2276	Pass	78819.223	Pass
70	3.6	78819.0792	Pass	78819.1164	Pass	78819.1044	Pass	78819.0776	Pass
60	3.6	78818.8256	Pass	78818.848	Pass	78818.8017	Pass	78818.783	Pass
50	3.6	78818.8079	Pass	78818.8	Pass	78818.7658	Pass	78818.7686	Pass
40	3.6	78819.2295	Pass	78819.2378	Pass	78819.2501	Pass	78819.2341	Pass
30	3.6	78819.259	Pass	78819.2599	Pass	78819.2573	Pass	78819.2649	Pass
20	3.6	78819.0694	Pass	78819.0803	Pass	78819.0475	Pass	78819.0672	Pass
10	3.6	78819.1598	Pass	78819.0866	Pass	78819.0908	Pass	78819.157	Pass
0	3.6	78818.9455	Pass	78818.9342	Pass	78818.9101	Pass	78818.9615	Pass
-10	3.6	78819.3435	Pass	78819.3867	Pass	78819.3937	Pass	78819.3359	Pass
-20	3.6	78818.7784	Pass	78818.72	Pass	78818.7585	Pass	78818.7587	Pass
-30	3.6	78818.6888	Pass	78818.7078	Pass	78818.6716	Pass	78818.6805	Pass
-40	3.6	78819.2055	Pass	78819.2327	Pass	78819.1931	Pass	78819.233	Pass

Frequency Stability Versus Voltage									
Operating Frequency: 78819 MHz									
Temp. (°C)	Power Supply (Vdc)	0 Minute		2 Minutes		5 Minutes		10 Minutes	
		Measured Frequency (MHz)	Test Result	Measured Frequency (MHz)	Test Result	Measured Frequency (MHz)	Test Result	Measured Frequency (MHz)	Test Result
20	4.14	78819.1838	Pass	78819.1327	Pass	78819.1861	Pass	78819.1418	Pass
	3.6	78819.0694	Pass	78819.0803	Pass	78819.0475	Pass	78819.0672	Pass
	3.06	78819.1448	Pass	78819.1537	Pass	78819.1478	Pass	78819.1655	Pass

Frequency Stability Versus Temperature

Operating Frequency: 78984 MHz

Temp. (°C)	Power Supply (Vdc)	0 Minute		2 Minutes		5 Minutes		10 Minutes	
		Measured Frequency (MHz)	Test Result	Measured Frequency (MHz)	Test Result	Measured Frequency (MHz)	Test Result	Measured Frequency (MHz)	Test Result
85	3.6	78983.8937	Pass	78983.8763	Pass	78983.9075	Pass	78983.8928	Pass
80	3.6	78983.6857	Pass	78983.7014	Pass	78983.6753	Pass	78983.6747	Pass
70	3.6	78984.4106	Pass	78984.373	Pass	78984.407	Pass	78984.41	Pass
60	3.6	78983.6167	Pass	78983.6431	Pass	78983.6217	Pass	78983.6279	Pass
50	3.6	78983.7949	Pass	78983.791	Pass	78983.8607	Pass	78983.8095	Pass
40	3.6	78983.7605	Pass	78983.7147	Pass	78983.752	Pass	78983.761	Pass
30	3.6	78984.0648	Pass	78984.0697	Pass	78984.0131	Pass	78984.0457	Pass
20	3.6	78984.0708	Pass	78984.0858	Pass	78984.0778	Pass	78984.0436	Pass
10	3.6	78984.1266	Pass	78984.1572	Pass	78984.1864	Pass	78984.1777	Pass
0	3.6	78983.9769	Pass	78983.9906	Pass	78983.9915	Pass	78983.9889	Pass
-10	3.6	78983.8608	Pass	78983.9292	Pass	78983.8612	Pass	78983.9072	Pass
-20	3.6	78984.3592	Pass	78984.3047	Pass	78984.3103	Pass	78984.3145	Pass
-30	3.6	78983.7545	Pass	78983.7776	Pass	78983.7663	Pass	78983.7422	Pass
-40	3.6	78983.6993	Pass	78983.7096	Pass	78983.7529	Pass	78983.7599	Pass

Frequency Stability Versus Voltage

Operating Frequency: 78984 MHz

Temp. (°C)	Power Supply (Vdc)	0 Minute		2 Minutes		5 Minutes		10 Minutes	
		Measured Frequency (MHz)	Test Result	Measured Frequency (MHz)	Test Result	Measured Frequency (MHz)	Test Result	Measured Frequency (MHz)	Test Result
20	4.14	78983.9794	Pass	78984.0112	Pass	78983.9527	Pass	78984.0123	Pass
	3.6	78984.0708	Pass	78984.0858	Pass	78984.0778	Pass	78984.0436	Pass
	3.06	78984.0652	Pass	78984.0991	Pass	78984.0972	Pass	78984.0609	Pass

5 Pictures of Test Arrangements

Please refer to the attached file (Test Setup Photo).

Appendix – Information of the Testing Laboratories

We, Bureau Veritas Consumer Products Services (H.K.) Ltd., Taoyuan Branch, were founded in 1988 to provide our best service in EMC, Radio, Telecom and Safety consultation. Our laboratories are FCC recognized accredited test firms and accredited according to ISO/IEC 17025.

If you have any comments, please feel free to contact us at the following:

Lin Kou EMC/RF Lab

Tel: 886-2-26052180

Fax: 886-2-26051924

Hsin Chu EMC/RF/Telecom Lab

Tel: 886-3-6668565

Fax: 886-3-6668323

Hwa Ya EMC/RF/Safety Lab

Tel: 886-3-3183232

Fax: 886-3-3270892

Email: service.adt@bureauveritas.com

Web Site: <http://ee.bureauveritas.com.tw>

The address and road map of all our labs can be found in our web site also.

--- END ---