

## FCC Test Report

**Report No.:** RF180904C01

**FCC ID:** L6AITC100-1

**Test Model:** ITC100-1

**Received Date:** Sep. 04, 2018

**Test Date:** Sep. 26, 2018 ~ Oct. 03, 2018

**Issued Date:** Oct. 16, 2018

**Applicant:** BlackBerry Limited

**Address:** 2200 University Avenue East Waterloo, Ontario N2K 0A7 Canada

**Issued By:** Bureau Veritas Consumer Products Services (H.K.) Ltd., Taoyuan Branch

**Lab Address:** No. 47-2, 14th Ling, Chia Pau Vil., Lin Kou Dist., New Taipei City, Taiwan  
( R.O.C )

**Test Location:** No. 19, Hwa Ya 2nd Rd, Wen Hwa Vil, Kwei Shan Dist., Taoyuan City  
33383, Taiwan (R.O.C)

**FCC Registration /  
Designation Number:** 788550 / TW0003



This report is for your exclusive use. Any copying or replication of this report to or for any other person or entity, or use of our name or trademark, is permitted only with our prior written permission. This report sets forth our findings solely with respect to the test samples identified herein. The results set forth in this report are not indicative or representative of the quality or characteristics of the lot from which a test sample was taken or any similar or identical product unless specifically and expressly noted. Our report includes all of the tests requested by you and the results thereof based upon the information that you provided to us. You have 60 days from date of issuance of this report to notify us of any material error or omission caused by our negligence, provided, however, that such notice shall be in writing and shall specifically address the issue you wish to raise. A failure to raise such issue within the prescribed time shall constitute your unqualified acceptance of the completeness of this report, the tests conducted and the correctness of the report contents. Unless specifically mentioned, the uncertainty of measurement has been explicitly taken into account to declare the compliance or non-compliance to the specification. The report must not be used by the client to claim product certification, approval, or endorsement by TAF or any government agencies.

## Table of Contents

<b>Release Control Record .....</b>	<b>4</b>
<b>1 Certificate of Conformity .....</b>	<b>5</b>
<b>2 Summary of Test Results .....</b>	<b>6</b>
2.1 Measurement Uncertainty .....	6
2.2 Modification Record.....	6
<b>3 General Information .....</b>	<b>7</b>
3.1 General Description of EUT .....	7
3.2 Description of Test Modes .....	8
3.2.1 Test Mode Applicability and Tested Channel Detail .....	9
3.3 Duty Cycle of Test Signal .....	10
3.4 Description of Support Units.....	10
3.4.1 Configuration of System under Test.....	10
3.5 General Description of Applied Standards .....	10
<b>4 Test Types and Results .....</b>	<b>11</b>
4.1 Radiated Emission and Bandedge Measurement .....	11
4.1.1 Limits of Radiated Emission and Bandedge Measurement.....	11
4.1.2 Test Instruments .....	12
4.1.3 Test Procedures.....	13
4.1.4 Deviation from Test Standard.....	13
4.1.5 Test Set Up .....	14
4.1.6 EUT Operating Conditions .....	15
4.1.7 Test Results .....	16
4.2 6 dB Bandwidth Measurement .....	31
4.2.1 Limits of 6 dB Bandwidth Measurement.....	31
4.2.2 Test Setup.....	31
4.2.3 Test Instruments .....	31
4.2.4 Test Procedure .....	31
4.2.5 Deviation from Test Standard.....	31
4.2.6 EUT Operating Conditions .....	31
4.2.7 Test Results .....	32
4.3 Occupied Bandwidth Measurement .....	33
4.3.1 Test Setup.....	33
4.3.2 Test Instruments .....	33
4.3.3 Test Procedure .....	33
4.3.4 Deviation from Test Standard.....	33
4.3.5 EUT Operating Conditions .....	33
4.3.6 Test Results .....	34
4.4 Conducted Output Power Measurement .....	35
4.4.1 Limits of Conducted Output Power Measurement.....	35
4.4.2 Test Setup.....	35
4.4.3 Test Instruments .....	35
4.4.4 Test Procedures.....	35
4.4.5 Deviation from Test Standard.....	35
4.4.6 EUT Operating Conditions .....	35
4.4.7 Test Results .....	36
4.5 Power Spectral Density Measurement .....	37
4.5.1 Limits of Power Spectral Density Measurement .....	37
4.5.2 Test Setup.....	37
4.5.3 Test Instruments .....	37
4.5.4 Test Procedure .....	37
4.5.5 Deviation from Test Standard.....	37
4.5.6 EUT Operating Condition .....	37
4.5.7 Test Results .....	38

4.6	Conducted Out of Band Emission Measurement .....	39
4.6.1	Limits of Conducted Out of Band Emission Measurement .....	39
4.6.2	Test Setup .....	39
4.6.3	Test Instruments .....	39
4.6.4	Test Procedure .....	39
4.6.5	Deviation from Test Standard .....	39
4.6.6	EUT Operating Condition .....	39
4.6.7	Test Results .....	40
<b>5</b>	<b>Pictures of Test Arrangements .....</b>	<b>42</b>
	<b>Appendix – Information on the Testing Laboratories .....</b>	<b>43</b>

### Release Control Record

Issue No.	Description	Date Issued
RF180904C01	Original Release	Oct. 16, 2018

## 1 Certificate of Conformity

**Product:** Asset Tracker  
**Brand:** BlackBerry  
**Test Model:** ITC100-1  
**Sample Status:** Identical Prototype  
**Applicant:** BlackBerry Limited  
**Test Date:** Sep. 26, 2018 ~ Oct. 03, 2018  
**Standards:** 47 CFR FCC Part 15, Subpart C (Section 15.247)  
ANSI C63.10:2013

The above equipment has been tested by **Bureau Veritas Consumer Products Services (H.K.) Ltd., Taoyuan Branch**, and found compliance with the requirement of the above standards. The test record, data evaluation & Equipment Under Test (EUT) configurations represented herein are true and accurate accounts of the measurements of the sample's RF characteristics under the conditions specified in this report.

**Prepared by :** Rona Chen , **Date:** Oct. 16, 2018  
Rona Chen / Specialist

**Approved by :** Dylan Chiou , **Date:** Oct. 16, 2018  
Dylan Chiou / Project Engineer

## 2 Summary of Test Results

47 CFR FCC Part 15, Subpart C (Section 15.247)			
FCC Clause	Test Item	Result	Remarks
15.207	AC Power Conducted Emission	N/A	Without AC port of EUT
15.205 & 209	Radiated Emissions	Pass	Meet the requirement of limit. Minimum passing margin is -0.67 dB at 902 MHz.
15.247(d)	Band Edge Measurement	Pass	Meet the requirement of limit.
15.247(d)	Antenna Port Emission	Pass	Meet the requirement of limit.
15.247(a)(2)	6 dB Bandwidth	Pass	Meet the requirement of limit.
---	Occupied Bandwidth Measurement	Pass	Reference only
15.247(b)	Conducted Power	Pass	Meet the requirement of limit.
15.247(e)	Power Spectral Density	Pass	Meet the requirement of limit.
15.203	Antenna Requirement	Pass	No antenna connector is used.

N/A: Not Applicable

### 2.1 Measurement Uncertainty

Where relevant, the following measurement uncertainty levels have been estimated for tests performed on the EUT as specified in CISPR 16-4-2:

Measurement	Frequency	Expanded Uncertainty (k=2) (±)
Conducted Emissions at mains ports	150 kHz ~ 30 MHz	2.44 dB
Radiated Emissions up to 1 GHz	30 MHz ~ 200 MHz	2.93 dB
	200 MHz ~ 1000 MHz	2.95 dB
Radiated Emissions above 1 GHz	1 GHz ~ 18 GHz	2.26 dB
	18 GHz ~ 40 GHz	1.94 dB

### 2.2 Modification Record

There were no modifications required for compliance.

### 3 General Information

#### 3.1 General Description of EUT

<b>Product</b>	Asset Tracker	
<b>Brand</b>	BlackBerry	
<b>Test Model</b>	ITC100-1	
<b>Status of EUT</b>	Identical Prototype	
<b>Power Supply Rating</b>	7.2 Vdc (Battery)	
<b>Modulation Type</b>	2GFSK, 4GFSK	
<b>Transfer Rate</b>	50 kbps, 150 kbps, 500 kbps	
<b>Operating Frequency</b>	902 ~ 928 MHz	
<b>Number of Channel</b>	25	
<b>Output Power</b>	68.077 mW	
<b>Antenna Type</b>	Monopole Antenna with	-5.4 dBi gain (Main SRD) -4.7 dBi gain (Secondary SRD)
<b>Antenna Connector</b>	N/A	
<b>Accessory Device</b>	Refer to Note as below	
<b>Data Cable Supplied</b>	Refer to Note as below	

Note:

1. The EUT contains Main and Secondary SRD module. Only test item Output Power was evaluated two modules. And the worst case of Output Power was chosen for other test items.
2. The EUT contains following accessory devices.

Product	Brand	Model	Description
Battery 1	BlackBerry	BAT-63320-001	7.2 Vdc, 38 Ah, Non-rechargeable Manufacturer: EVE Energy Co., Ltd.
Battery 2	BlackBerry	BAT-63318-001	7.2 Vdc, 19 Ah, Non-rechargeable Manufacturer: EVE Energy Co., Ltd.

- Above batteries had been pre-tested, and the worst case was found when EUT with Battery 1. Therefore, only this configuration was as a representative for final test.
3. The above EUT information is declared by manufacturer and for more detailed features description, please refers to the manufacturer's specifications or user's manual.

### 3.2 Description of Test Modes

25 channels are provided to this EUT:

Channel	Freq. (MHz)	Channel	Freq. (MHz)	Channel	Freq. (MHz)
1	903	10	912	19	921
2	904	11	913	20	922
3	905	12	914	21	923
4	906	13	915	22	924
5	907	14	916	23	925
6	908	15	917	24	926
7	909	16	918	25	927
8	910	17	919		
9	911	18	920		



### 3.2.1 Test Mode Applicability and Tested Channel Detail

EUT Configure Mode	Applicable To				Description
	RE $\geq$ 1G	RE<1G	PLC	APCM	
-	√	√	-	√	-

Where **RE $\geq$ 1G**: Radiated Emission above 1 GHz      **RE<1G**: Radiated Emission below 1 GHz  
**PLC**: Power Line Conducted Emission      **APCM**: Antenna Port Conducted Measurement

**Note:** 1. The EUT had been pre-tested on the positioned of each 3 axis. The worst case was found when positioned on **X-plane**.  
2. "-" means no effect.

#### **Radiated Emission Test (Above 1 GHz):**

- Pre-Scan has been conducted to determine the worst-case mode from all possible combinations between available modulations, data rates and antenna ports (if EUT with antenna diversity architecture).
- Following channel(s) was (were) selected for the final test as listed below.

EUT Configure Mode	Available Channel	Tested Channel	Modulation Type	Data Rate (kbps)
-	1 to 25	1, 13, 25	2GFSK	50

#### **Radiated Emission Test (Below 1 GHz):**

- Pre-Scan has been conducted to determine the worst-case mode from all possible combinations between available modulations, data rates and antenna ports (if EUT with antenna diversity architecture).
- Following channel(s) was (were) selected for the final test as listed below.

EUT Configure Mode	Available Channel	Tested Channel	Modulation Type	Data Rate (kbps)
-	1 to 25	1, 13, 25	2GFSK	50

#### **Antenna Port Conducted Measurement:**

- This item includes all test value of each mode, but only includes spectrum plot of worst value of each mode.
- Pre-Scan has been conducted to determine the worst-case mode from all possible combinations between available modulations, data rates and antenna ports (if EUT with antenna diversity architecture).
- Following channel(s) was (were) selected for the final test as listed below.

EUT Configure Mode	Available Channel	Tested Channel	Modulation Type	Data Rate (kbps)
-	1 to 25	1, 13, 25	2GFSK	50

#### **Test Condition:**

Applicable To	Environmental Conditions	Input Power	Tested by
RE $\geq$ 1G	25 deg. C, 65 % RH	7.2 Vdc	Thomas Wei
RE<1G	25 deg. C, 65 % RH	7.2 Vdc	Thomas Wei
APCM	25 deg. C, 65 % RH	7.2 Vdc	Leo Tsai

### 3.3 Duty Cycle of Test Signal

Duty cycle of test signal is 100 %, duty factor is not required.

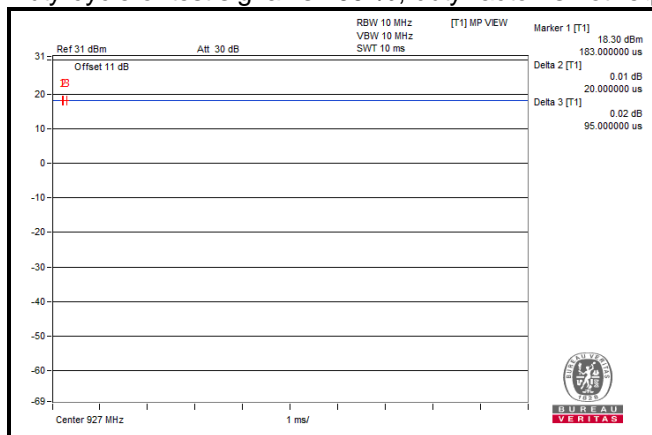

### 3.4 Description of Support Units

The EUT has been tested as an independent unit together with other necessary accessories or support units.

#### 3.4.1 Configuration of System under Test

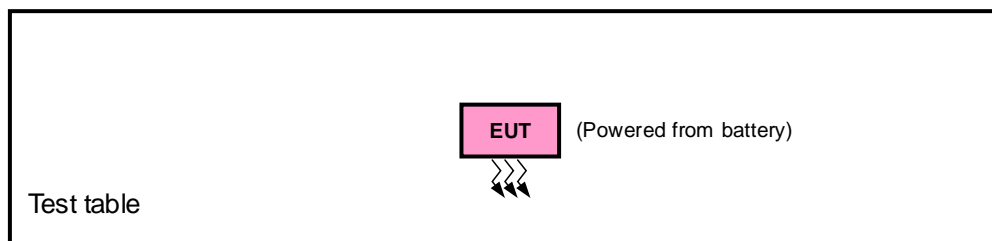

### 3.5 General Description of Applied Standards

The EUT is a RF Product. According to the specifications of the manufacturer, it must comply with the requirements of the following standards:

**FCC Part 15, Subpart C (15.247)**

**KDB 558074 D01 15.247 Meas Guidance v05**

ANSI C63.10-2013

All test items have been performed and recorded as per the above standards.

## 4 Test Types and Results

### 4.1 Radiated Emission and Bandedge Measurement

#### 4.1.1 Limits of Radiated Emission and Bandedge Measurement

Radiated emissions which fall in the restricted bands must comply with the radiated emission limits specified as below table. Other emissions shall be at least 20 dB below the highest level of the desired power:

Frequencies (MHz)	Field Strength (microvolts/meter)	Measurement Distance (meters)
0.009 ~ 0.490	2400/F (kHz)	300
0.490 ~ 1.705	24000/F (kHz)	30
1.705 ~ 30.0	30	30
30 ~ 88	100	3
88 ~ 216	150	3
216 ~ 960	200	3
Above 960	500	3

**Note:**

1. The lower limit shall apply at the transition frequencies.
2. Emission level (dBuV/m) = 20 log Emission level (uV/m).
3. For frequencies above 1000 MHz, the field strength limits are based on average detector, however, the peak field strength of any emission shall not exceed the maximum permitted average limits, specified above by more than 20 dB under any condition of modulation.

## 4.1.2 Test Instruments

Description & Manufacturer	Model No.	Serial No.	Date of Calibration	Due Date of Calibration
Test Receiver Agilent	N9038A	MY51210203	Mar. 16, 2018	Mar. 15, 2019
Spectrum Analyzer Agilent	N9010A	MY52220314	Nov. 24, 2017	Nov. 23, 2018
Spectrum Analyzer ROHDE & SCHWARZ	FSU43	101261	Jan. 11, 2018	Jan. 10, 2019
Double Ridge Guide Horn Antenna EMCO	3115	5619	Nov. 30, 2017	Nov. 29, 2018
BILOG Antenna SCHWARZBECK	VULB 9168	9168-153	Dec. 06, 2017	Dec. 05, 2018
RF signal cable ETS-LINDGREN	5D-FB	Cable-CH1-01(R FC-SMS-100-SM S-120+RFC-SMS -100-SMS-400)	Jun. 19, 2018	Jun. 18, 2019
Fixed Attenuator	BW-N4W5+	1301	Aug. 13, 2018	Aug. 12, 2019
Loop Antenna	EM-6879	269	Sep. 07, 2018	Sep. 06, 2019
Preamplifier EMCI	EMC 012645	980115	Oct. 20, 2017	Oct. 19, 2018
Preamplifier EMCI	EMC 184045	980116	Oct. 20, 2017	Oct. 19, 2018
Preamplifier EMCI	EMC 330H	980112	Oct. 13, 2017	Oct. 12, 2018
Power Meter Anritsu	ML2495A	1012010	Sep. 05, 2018	Sep. 04, 2019
Power Sensor Anritsu	MA2411B	1315050	Sep. 04, 2018	Sep. 05, 2019
RF Coaxial Cable HUBER+SUHNNER	EMC104-SM-SM-8 000&3000	140811+170717	Oct. 20, 2017	Oct. 19, 2018
RF Coaxial Cable HUBER+SUHNNER	SUCOFLEX 104	EMC104-SM-SM- 1000(140807)	Oct. 20, 2017	Oct. 19, 2018
Boresight Antenna Fixture	FBA-01	FBA-SIP01	NA	NA
Software BV ADT	E3 6.120103	NA	NA	NA
Antenna Tower MF	MFA-440H	NA	NA	NA
Turn Table MF	MFT-201SS	NA	NA	NA
Antenna Tower & Turn Table Controller MF	MF-7802	NA	NA	NA

- Note: 1. The calibration interval of the above test instruments is 12 months and the calibrations are traceable to NML/ROC and NIST/USA.
2. The test was performed in HwaYa Chamber 10.
3. The horn antenna and preamplifier (model: EMC 184045) are used only for the measurement of emission frequency above 1GHz if tested.
4. The IC Site Registration No. is IC7450F-10.

#### 4.1.3 Test Procedures

##### **For Radiated Emission below 30 MHz**

- a. The EUT was placed on the top of a rotating table 0.8 meters above the ground at a 3 meter chamber room. The table was rotated 360 degrees to determine the position of the highest radiation.
- b. The EUT was set 3 meters away from the interference-receiving antenna, which was mounted on the top of a variable-height antenna tower.
- c. Parallel, perpendicular, and ground-parallel orientations of the antenna are set to make the measurement.
- d. For each suspected emission, the EUT was arranged to its worst case and the rotatable table was turned from 0 degrees to 360 degrees to find the maximum reading.
- e. The test-receiver system was set to Quasi-Peak Detect Function and Specified Bandwidth with Maximum Hold Mode.

##### **Note:**

1. The resolution bandwidth and video bandwidth of test receiver/spectrum analyzer is 9 kHz at frequency below 30 MHz.

##### **For Radiated Emission above 30 MHz**

- a. The EUT was placed on the top of a rotating table 0.8 meters (for 30 MHz ~ 1 GHz) / 1.5 meters (for above 1 GHz) above the ground at 3 meter chamber room for test. The table was rotated 360 degrees to determine the position of the highest radiation.
- b. The EUT was set 3 meters away from the interference-receiving antenna, which was mounted on the top of a variable-height antenna tower.
- c. The height of antenna is varied from one meter to four meters above the ground to determine the maximum value of the field strength. Both horizontal and vertical polarizations of the antenna are set to make the measurement.
- d. For each suspected emission, the EUT was arranged to its worst case and then the antenna was tuned to heights from 1 meter to 4 meters and the rotatable table was turned from 0 degrees to 360 degrees to find the maximum reading.
- e. The test-receiver system was set to quasi-peak detect function and specified bandwidth with maximum hold mode when the test frequency is below 1 GHz.
- f. The test-receiver system was set to peak and average detected function and specified bandwidth with maximum hold mode when the test frequency is above 1 GHz. If the peak reading value also meets average limit, measurement with the average detector is unnecessary.

##### **Note:**

1. The resolution bandwidth and video bandwidth of test receiver/spectrum analyzer is 120 kHz for Quasi-peak detection (QP) at frequency below 1 GHz.
2. The resolution bandwidth of test receiver/spectrum analyzer is 1 MHz and the video bandwidth is 3 MHz for Peak detection (PK) at frequency above 1 GHz.
3. The resolution bandwidth of test receiver/spectrum analyzer is 1 MHz and the video bandwidth is  $\geq 1/T$  (Duty cycle < 98 %) or 10 Hz (Duty cycle  $\geq 98$  %) for Average detection (AV) at frequency above 1 GHz. (RBW = 1 MHz, VBW = 3 kHz)
4. All modes of operation were investigated and the worst-case emissions are reported.

#### 4.1.4 Deviation from Test Standard

No deviation.

4.1.5 Test Set Up

<Radiated Emission below 30 MHz>

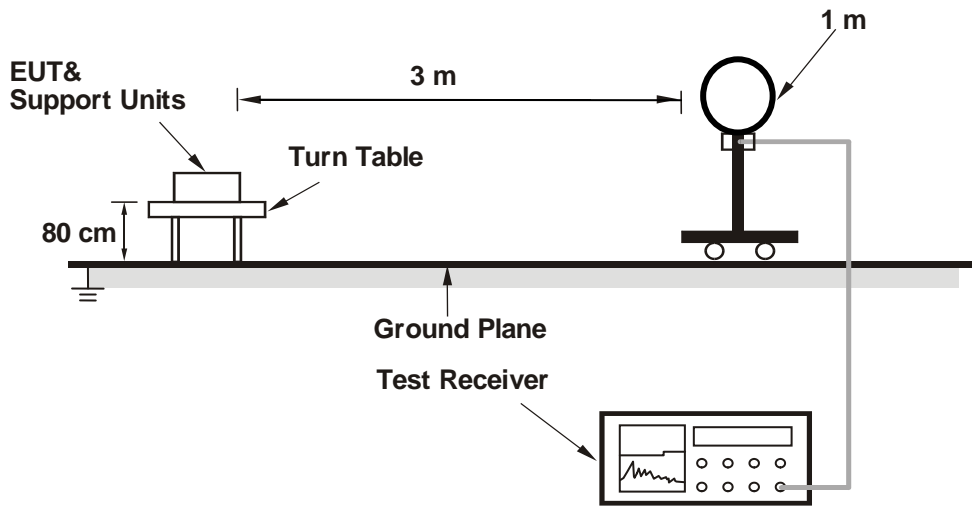

<Radiated Emission 30 MHz to 1 GHz>

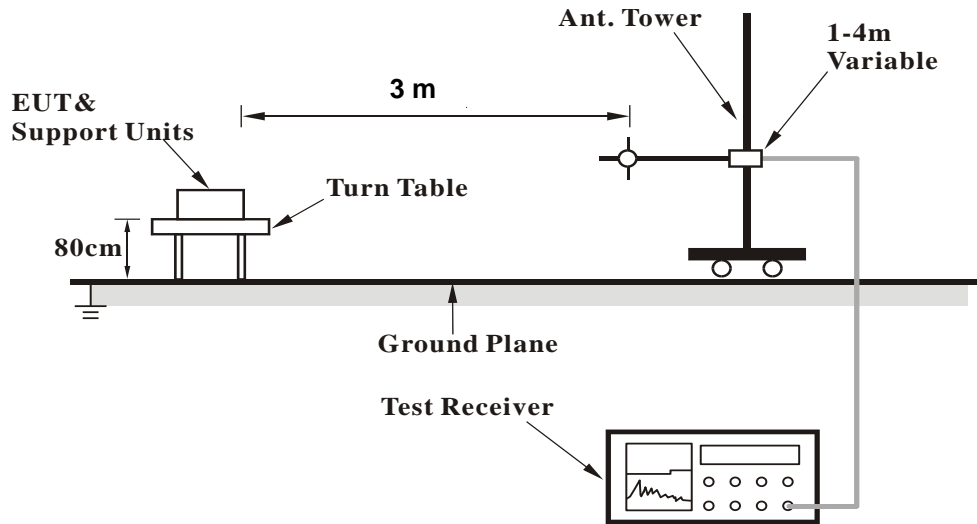

### <Radiated Emission above 1 GHz>

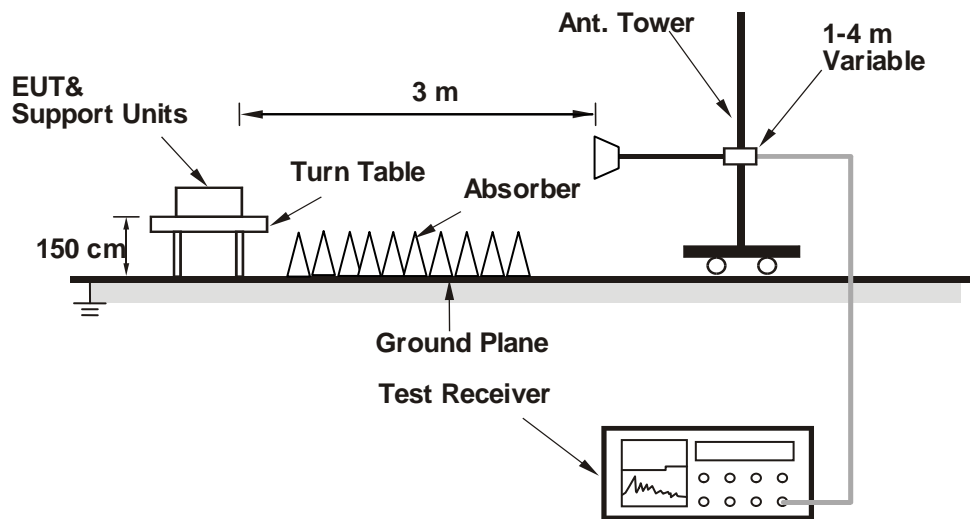

For the actual test configuration, please refer to the attached file (Test Setup Photo).

#### 4.1.6 EUT Operating Conditions

- Placed the EUT on the testing table.
- Set the EUT under transmission condition continuously at specific channel frequency.

4.1.7 Test Results

Above 1 GHz Data:

EUT Test Condition		Measurement Detail	
Channel	Channel 1	Frequency Range	1 GHz ~ 10 GHz
Input Power	7.2 Vdc	Detector Function	Peak (PK) Average (AV)
Environmental Conditions	25 deg. C, 65 % RH	Tested By	Thomas Wei

Antenna Polarity & Test Distance: Horizontal at 3 m										
Frequency (MHz)	Emission Level (dBuV/m)	Read Level (dBuV)	Limit (dBuV/m)	Margin (dB)	Antenna Factor (dB/m)	Cable Loss (dB)	Preamp Factor (dB)	Antenna Height (cm)	Table Angle (Degree)	Remark
2709	53.24	74.2	54	-0.76	27.95	5.14	54.05	152	338	Average
2709	57.04	78	74	-16.96	27.95	5.14	54.05	152	338	Peak
Antenna Polarity & Test Distance: Vertical at 3 m										
Frequency (MHz)	Emission Level (dBuV/m)	Read Level (dBuV)	Limit (dBuV/m)	Margin (dB)	Antenna Factor (dB/m)	Cable Loss (dB)	Preamp Factor (dB)	Antenna Height (cm)	Table Angle (Degree)	Remark
2709	48.05	69.01	54	-5.95	27.95	5.14	54.05	133	204	Average
2709	50.14	71.1	74	-23.86	27.95	5.14	54.05	133	204	Peak

Remarks:

- Emission Level = Read Level + Antenna Factor + Cable Loss - Preamp Factor  
Margin value = Emission level – Limit value
- 903 MHz: Fundamental frequency.
- The emission levels of other frequencies were very low against the limit.



EUT Test Condition		Measurement Detail	
Channel	Channel 13	Frequency Range	1 GHz ~ 10 GHz
Input Power	7.2 Vdc	Detector Function	Peak (PK) Average (AV)
Environmental Conditions	25 deg. C, 65 % RH	Tested By	Thomas Wei

Antenna Polarity & Test Distance: Horizontal at 3 m										
Frequency (MHz)	Emission Level (dBuV/m)	Read Level (dBuV)	Limit (dBuV/m)	Margin (dB)	Antenna Factor (dB/m)	Cable Loss (dB)	Preamp Factor (dB)	Antenna Height (cm)	Table Angle (Degree)	Remark
2745	53.15	74.01	54	-0.85	28	5.18	54.04	119	337	Average
2745	55.15	76	74	-18.85	28.01	5.18	54.04	119	337	Peak
Antenna Polarity & Test Distance: Vertical at 3 m										
Frequency (MHz)	Emission Level (dBuV/m)	Read Level (dBuV)	Limit (dBuV/m)	Margin (dB)	Antenna Factor (dB/m)	Cable Loss (dB)	Preamp Factor (dB)	Antenna Height (cm)	Table Angle (Degree)	Remark
2745	47.65	68.5	54	-6.35	28.01	5.18	54.04	107	270	Average
2745	50.22	71.07	74	-23.78	28.01	5.18	54.04	107	270	Peak

Remarks:

- Emission Level = Read Level + Antenna Factor + Cable Loss - Preamp Factor  
Margin value = Emission level – Limit value
- 915 MHz: Fundamental frequency.
- The emission levels of other frequencies were very low against the limit.

EUT Test Condition		Measurement Detail	
Channel	Channel 25	Frequency Range	1 GHz ~ 10 GHz
Input Power	7.2 Vdc	Detector Function	Peak (PK) Average (AV)
Environmental Conditions	25 deg. C, 65 % RH	Tested By	Thomas Wei

Antenna Polarity & Test Distance: Horizontal at 3 m										
Frequency (MHz)	Emission Level (dBuV/m)	Read Level (dBuV)	Limit (dBuV/m)	Margin (dB)	Antenna Factor (dB/m)	Cable Loss (dB)	Preamp Factor (dB)	Antenna Height (cm)	Table Angle (Degree)	Remark
2781	51.38	72.1	54	-2.62	28.06	5.23	54.01	148	339	Average
2781	56	76.72	74	-18	28.06	5.23	54.01	148	339	Peak
Antenna Polarity & Test Distance: Vertical at 3 m										
Frequency (MHz)	Emission Level (dBuV/m)	Read Level (dBuV)	Limit (dBuV/m)	Margin (dB)	Antenna Factor (dB/m)	Cable Loss (dB)	Preamp Factor (dB)	Antenna Height (cm)	Table Angle (Degree)	Remark
2781	44.62	65.34	54	-9.38	28.06	5.23	54.01	221	154	Average
2781	49.28	70	74	-24.72	28.06	5.23	54.01	221	154	Peak

Remarks:

- Emission Level = Read Level + Antenna Factor + Cable Loss - Preamp Factor  
Margin value = Emission level – Limit value
- 927 MHz: Fundamental frequency.
- The emission levels of other frequencies were very low against the limit.

**9 kHz ~ 30 MHz Data:**

The amplitude of spurious emissions attenuated more than 20 dB below the permissible value is not required to be report.

**30 MHz ~ 1 GHz Data:**

**<Spurious Emissions Measurement>**

EUT Test Condition		Measurement Detail	
Channel	Channel 1	Frequency Range	30 MHz ~ 1 GHz
Input Power	7.2 Vdc	Detector Function	Peak (PK) Quasi-peak (QP)
Environmental Conditions	25 deg. C, 65 % RH	Tested By	Thomas Wei

**Horizontal**

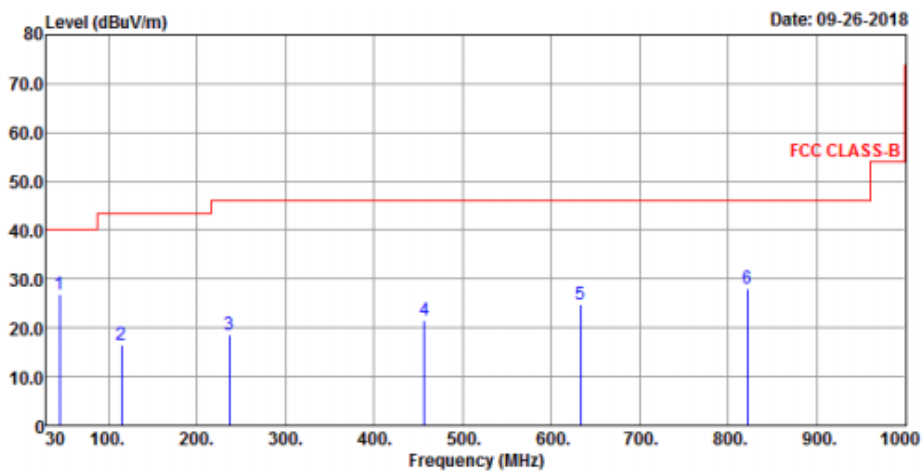

**Vertical**

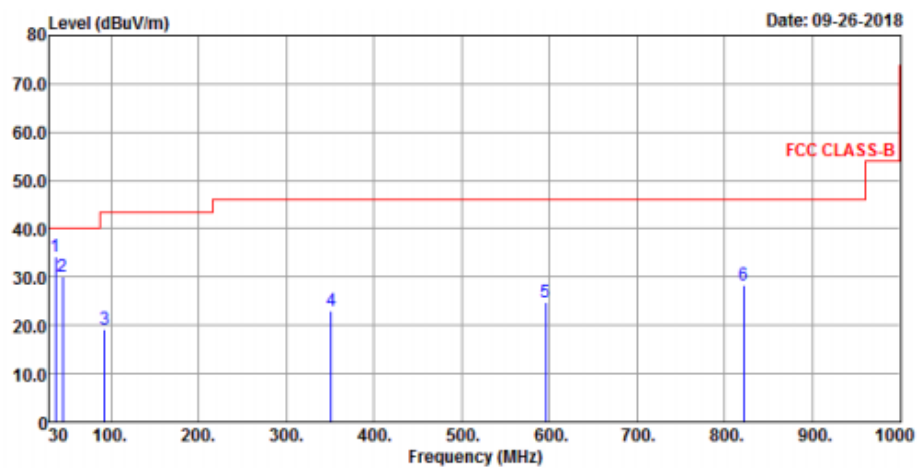

**Antenna Polarity & Test Distance: Horizontal at 3 m**

Frequency (MHz)	Emission Level (dBuV/m)	Read Level (dBuV)	Limit (dBuV/m)	Margin (dB)	Antenna Factor (dB/m)	Cable Loss (dB)	Preamp Factor (dB)	Antenna Height (cm)	Table Angle (Degree)	Remark
44.55	26.72	43.75	40	-13.28	13.6	0.51	31.14	128	206	Peak
114.39	16.42	37.02	43.5	-27.08	10.46	0.81	31.87	169	287	Peak
236.61	18.51	37.98	46	-27.49	10.91	1.42	31.8	236	69	Peak
456.8	21.53	34.75	46	-24.47	16.46	2.31	31.99	274	301	Peak
633.34	24.73	33.8	46	-21.27	20.01	3.04	32.12	154	181	Peak
821.52	28.06	33.43	46	-17.94	22.5	3.75	31.62	129	51	Peak

**Antenna Polarity & Test Distance: Vertical at 3 m**

Frequency (MHz)	Emission Level (dBuV/m)	Read Level (dBuV)	Limit (dBuV/m)	Margin (dB)	Antenna Factor (dB/m)	Cable Loss (dB)	Preamp Factor (dB)	Antenna Height (cm)	Table Angle (Degree)	Remark
36.79	34.16	51.62	40	-5.84	13.09	0.48	31.03	124	89	Peak
44.55	30.02	47.05	40	-9.98	13.6	0.51	31.14	158	91	Peak
93.05	19.17	41.88	43.5	-24.33	8.53	0.72	31.96	191	164	Peak
351.07	23.11	38.91	46	-22.89	14.17	1.88	31.85	233	201	Peak
595.51	24.72	34.54	46	-21.28	19.5	2.88	32.2	259	261	Peak
821.52	28.28	33.65	46	-17.72	22.5	3.75	31.62	281	306	Peak

Remarks:

- Emission Level = Read Level + Antenna Factor + Cable Loss - Preamp Factor  
Margin value = Emission level – Limit value
- The emission levels of other frequencies were very low against the limit.

EUT Test Condition		Measurement Detail	
Channel	Channel 13	Frequency Range	30 MHz ~ 1 GHz
Input Power	7.2 Vdc	Detector Function	Peak (PK) Quasi-peak (QP)
Environmental Conditions	25 deg. C, 65 % RH	Tested By	Thomas Wei

### Horizontal

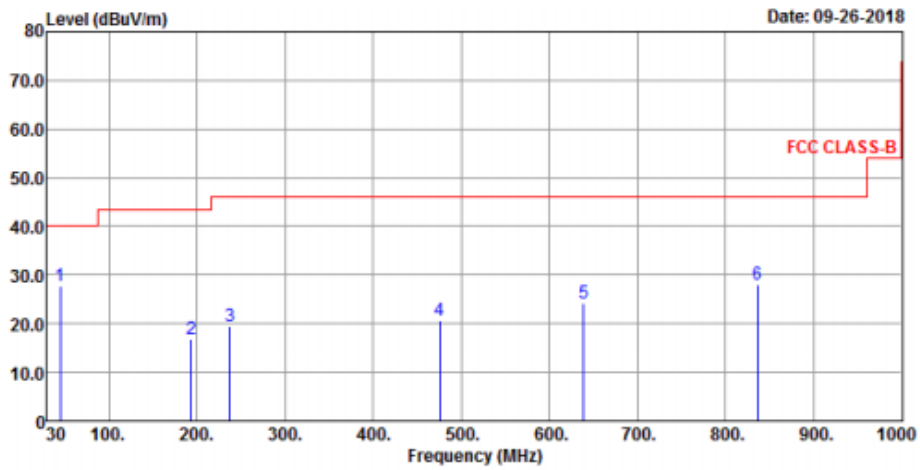

### Vertical

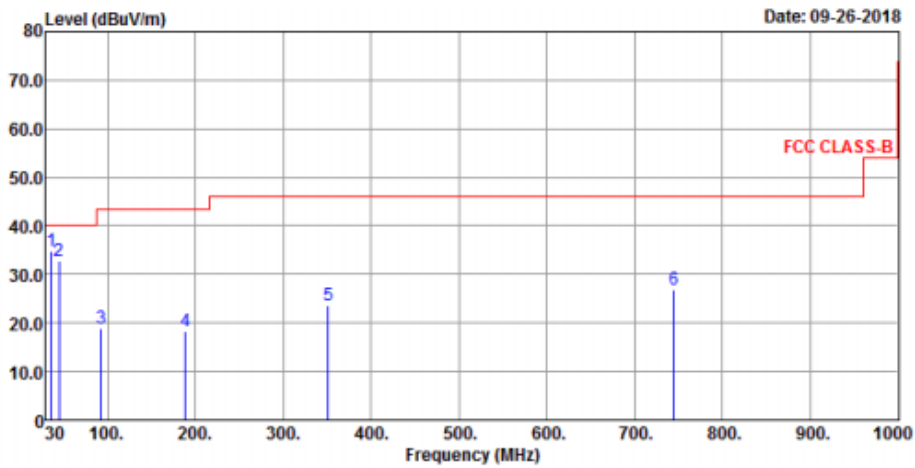

**Antenna Polarity & Test Distance: Horizontal at 3 m**

Frequency (MHz)	Emission Level (dBuV/m)	Read Level (dBuV)	Limit (dBuV/m)	Margin (dB)	Antenna Factor (dB/m)	Cable Loss (dB)	Preamp Factor (dB)	Antenna Height (cm)	Table Angle (Degree)	Remark
44.55	27.72	44.75	40	-12.28	13.6	0.51	31.14	156	233	Peak
193.93	16.76	37.51	43.5	-26.74	9.77	1.19	31.71	191	67	Peak
237.58	19.36	38.78	46	-26.64	10.95	1.43	31.8	207	34	Peak
475.23	20.7	33.35	46	-25.3	16.83	2.39	31.87	248	199	Peak
639.16	24.33	33.29	46	-21.67	20.08	3.06	32.1	267	241	Peak
836.07	28.12	33.41	46	-17.88	22.69	3.79	31.77	279	300	Peak

**Antenna Polarity & Test Distance: Vertical at 3 m**

Frequency (MHz)	Emission Level (dBuV/m)	Read Level (dBuV)	Limit (dBuV/m)	Margin (dB)	Antenna Factor (dB/m)	Cable Loss (dB)	Preamp Factor (dB)	Antenna Height (cm)	Table Angle (Degree)	Remark
35.82	34.69	52.33	40	-5.31	12.94	0.47	31.05	305	338	Peak
44.55	32.68	49.71	40	-7.32	13.6	0.51	31.14	289	294	Peak
93.05	18.85	41.56	43.5	-24.65	8.53	0.72	31.96	249	201	Peak
189.08	18.32	38.72	43.5	-25.18	10.12	1.17	31.69	184	159	Peak
351.07	23.75	39.55	46	-22.25	14.17	1.88	31.85	148	113	Peak
744.89	26.88	33.33	46	-19.12	21.45	3.49	31.39	125	55	Peak

Remarks:

- Emission Level = Read Level + Antenna Factor + Cable Loss - Preamp Factor  
Margin value = Emission level – Limit value
- The emission levels of other frequencies were very low against the limit.

EUT Test Condition		Measurement Detail	
Channel	Channel 25	Frequency Range	30 MHz ~ 1 GHz
Input Power	7.2 Vdc	Detector Function	Peak (PK) Quasi-peak (QP)
Environmental Conditions	25 deg. C, 65 % RH	Tested By	Thomas Wei

### Horizontal

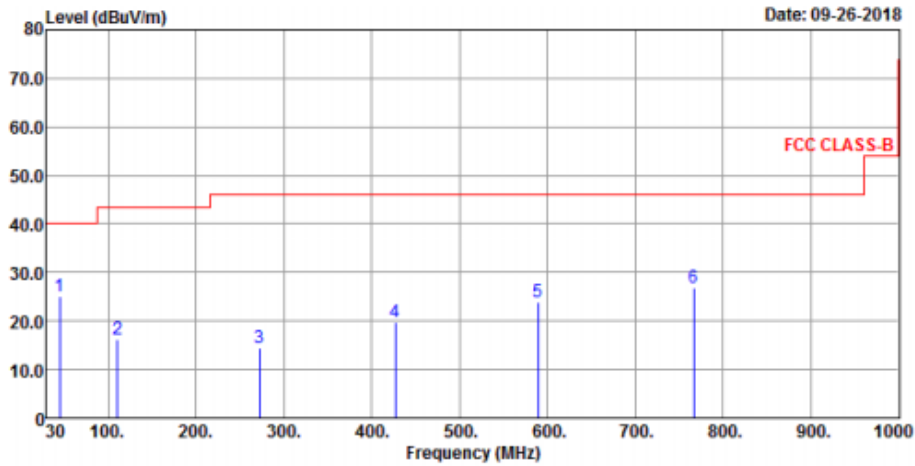

### Vertical

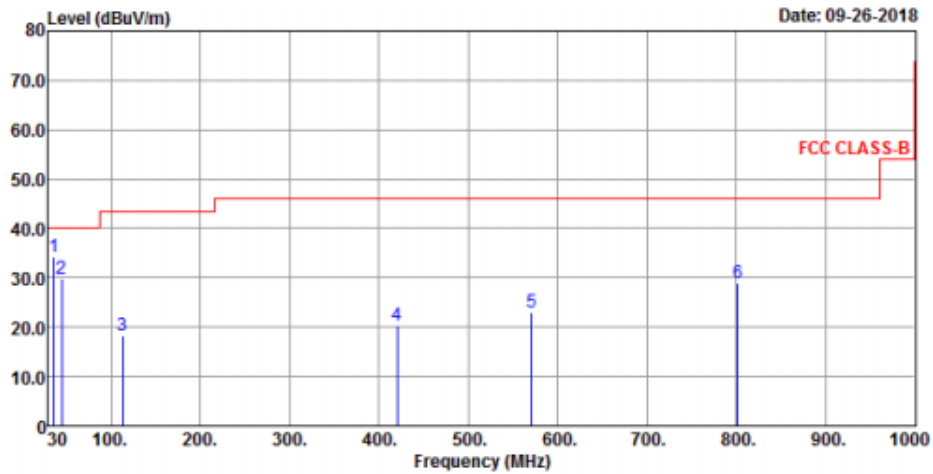

**Antenna Polarity & Test Distance: Horizontal at 3 m**

Frequency (MHz)	Emission Level (dBuV/m)	Read Level (dBuV)	Limit (dBuV/m)	Margin (dB)	Antenna Factor (dB/m)	Cable Loss (dB)	Preamp Factor (dB)	Antenna Height (cm)	Table Angle (Degree)	Remark
44.55	24.97	42	40	-15.03	13.6	0.51	31.14	155	316	Peak
110.51	16.17	37.14	43.5	-27.33	10.09	0.79	31.85	187	233	Peak
272.5	14.32	32.61	46	-31.68	12.14	1.54	31.97	214	269	Peak
426.73	19.69	33.66	46	-26.31	15.87	2.18	32.02	246	103	Peak
589.69	23.81	33.73	46	-22.19	19.37	2.85	32.14	279	124	Peak
766.23	26.98	33.03	46	-19.02	21.75	3.56	31.36	301	339	Peak

**Antenna Polarity & Test Distance: Vertical at 3 m**

Frequency (MHz)	Emission Level (dBuV/m)	Read Level (dBuV)	Limit (dBuV/m)	Margin (dB)	Antenna Factor (dB/m)	Cable Loss (dB)	Preamp Factor (dB)	Antenna Height (cm)	Table Angle (Degree)	Remark
35.82	34.23	51.87	40	-5.77	12.94	0.47	31.05	300	304	Peak
44.55	29.76	46.79	40	-10.24	13.6	0.51	31.14	259	234	Peak
113.42	18.32	39	43.5	-25.18	10.37	0.81	31.86	214	188	Peak
419.94	20.25	34.42	46	-25.75	15.73	2.15	32.05	176	126	Peak
570.29	23.02	33.4	46	-22.98	18.92	2.78	32.08	155	103	Peak
801.15	28.84	34.35	46	-17.16	22.24	3.68	31.43	125	58	Peak

Remarks:

- Emission Level = Read Level + Antenna Factor + Cable Loss - Preamp Factor  
Margin value = Emission level – Limit value
- The emission levels of other frequencies were very low against the limit.



<Band Edge Measurement>

EUT Test Condition		Measurement Detail	
Channel	Channel 1	Frequency Range	30 MHz ~ 1 GHz
Input Power	7.2 Vdc	Detector Function	Average (AV) Quasi-peak (QP)
Environmental Conditions	25 deg. C, 65 % RH	Tested By	Thomas Wei

Horizontal

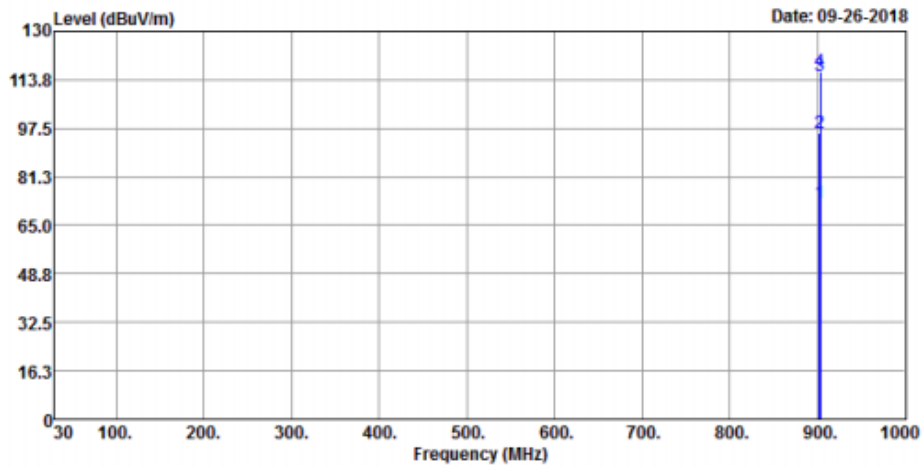

Vertical

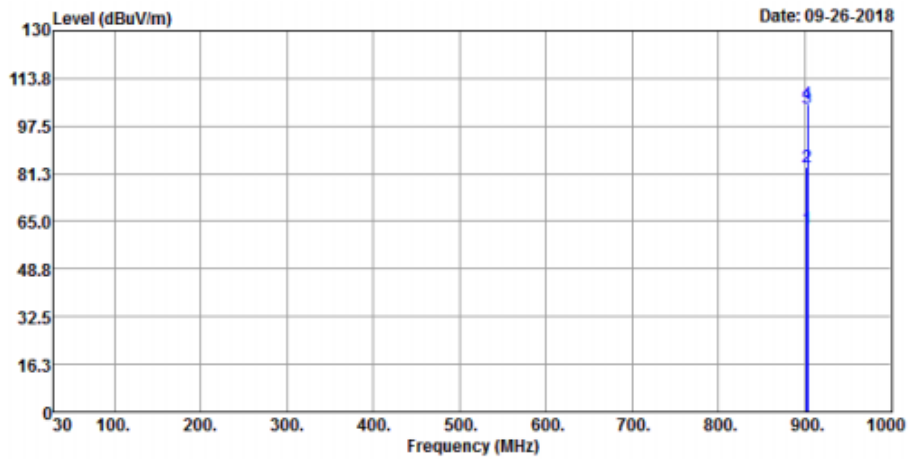

**Antenna Polarity & Test Distance: Horizontal at 3 m**

Frequency (MHz)	Emission Level (dBuV/m)	Read Level (dBuV)	Limit (dBuV/m)	Margin (dB)	Antenna Factor (dB/m)	Cable Loss (dB)	Preamp Factor (dB)	Antenna Height (cm)	Table Angle (Degree)	Remark
*902	72.33	76.78	94.95	-22.62	23.52	4.05	32.02	160	119	Average
<b>*902</b>	<b>96.05</b>	<b>100.5</b>	<b>96.72</b>	<b>-0.67</b>	<b>23.52</b>	<b>4.05</b>	<b>32.02</b>	<b>160</b>	<b>119</b>	<b>QP</b>
903	114.95	119.39	-----	-----	23.53	4.05	32.02	160	119	Average
903	116.72	121.16	-----	-----	23.53	4.05	32.02	160	119	QP

**Antenna Polarity & Test Distance: Vertical at 3 m**

Frequency (MHz)	Emission Level (dBuV/m)	Read Level (dBuV)	Limit (dBuV/m)	Margin (dB)	Antenna Factor (dB/m)	Cable Loss (dB)	Preamp Factor (dB)	Antenna Height (cm)	Table Angle (Degree)	Remark
*902	62.55	67	83.65	-21.1	23.52	4.05	32.02	104	126	Average
*902	83.64	88.09	85.15	-1.51	23.52	4.05	32.02	104	126	QP
903	103.65	108.09	-----	-----	23.53	4.05	32.02	104	126	Average
903	105.15	109.59	-----	-----	23.53	4.05	32.02	104	126	QP

Remarks:

- Emission Level = Read Level + Antenna Factor + Cable Loss - Preamp Factor  
Margin value = Emission level – Limit value
- The emission levels of other frequencies were very low against the limit.
- \*: Out of Restricted Band

EUT Test Condition		Measurement Detail	
Channel	Channel 13	Frequency Range	30 MHz ~ 1 GHz
Input Power	7.2 Vdc	Detector Function	Average (AV) Quasi-peak (QP)
Environmental Conditions	25 deg. C, 65 % RH	Tested By	Thomas Wei

**Horizontal**

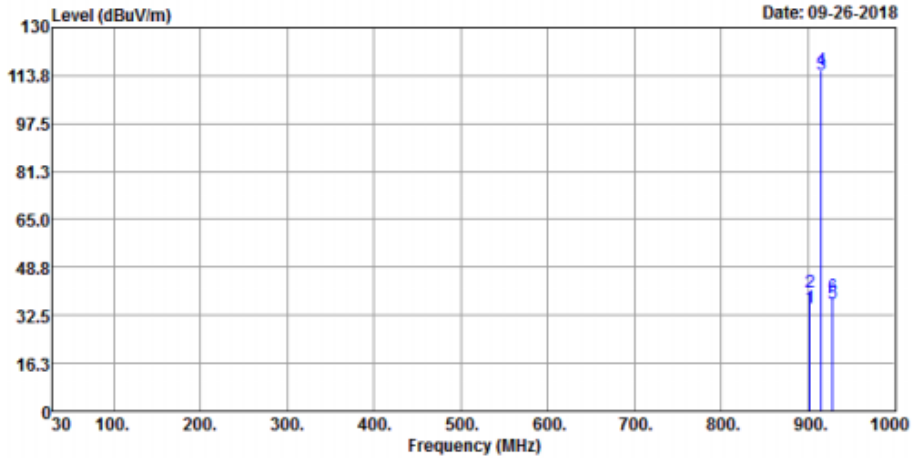

**Vertical**

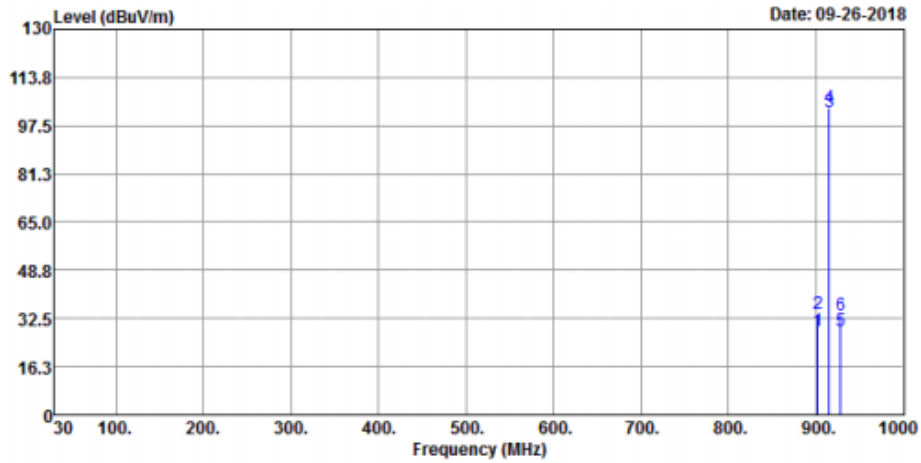

**Antenna Polarity & Test Distance: Horizontal at 3 m**

Frequency (MHz)	Emission Level (dBuV/m)	Read Level (dBuV)	Limit (dBuV/m)	Margin (dB)	Antenna Factor (dB/m)	Cable Loss (dB)	Preamp Factor (dB)	Antenna Height (cm)	Table Angle (Degree)	Remark
*902	34.85	39.3	94.18	-59.33	23.52	4.05	32.02	156	117	Average
*902	40.48	44.93	95.51	-55.03	23.52	4.05	32.02	156	117	QP
915	114.18	118.51	-----	-----	23.59	4.11	32.03	156	117	Average
915	115.51	119.84	-----	-----	23.59	4.11	32.03	156	117	QP
*928	36.44	40.6	94.18	-57.74	23.67	4.16	31.99	156	117	Average
*928	39.02	43.18	95.51	-56.49	23.67	4.16	31.99	156	117	QP

**Antenna Polarity & Test Distance: Vertical at 3 m**

Frequency (MHz)	Emission Level (dBuV/m)	Read Level (dBuV)	Limit (dBuV/m)	Margin (dB)	Antenna Factor (dB/m)	Cable Loss (dB)	Preamp Factor (dB)	Antenna Height (cm)	Table Angle (Degree)	Remark
*902	28.15	32.6	81.98	-53.83	23.52	4.05	32.02	101	128	Average
*902	34.23	38.68	83.44	-49.21	23.52	4.05	32.02	101	128	QP
915	101.98	106.31	-----	-----	23.59	4.11	32.03	101	128	Average
915	103.44	107.77	-----	-----	23.59	4.11	32.03	101	128	QP
*928	28.44	32.6	81.98	-53.54	23.67	4.16	31.99	101	128	Average
*928	33.37	37.53	83.44	-50.07	23.67	4.16	31.99	101	128	QP

Remarks:

- Emission Level = Read Level + Antenna Factor + Cable Loss - Preamp Factor  
Margin value = Emission level – Limit value
- The emission levels of other frequencies were very low against the limit.
- \*: Out of Restricted Band

EUT Test Condition		Measurement Detail	
Channel	Channel 25	Frequency Range	30 MHz ~ 1 GHz
Input Power	7.2 Vdc	Detector Function	Average (AV) Quasi-peak (QP)
Environmental Conditions	25 deg. C, 65 % RH	Tested By	Thomas Wei

**Horizontal**

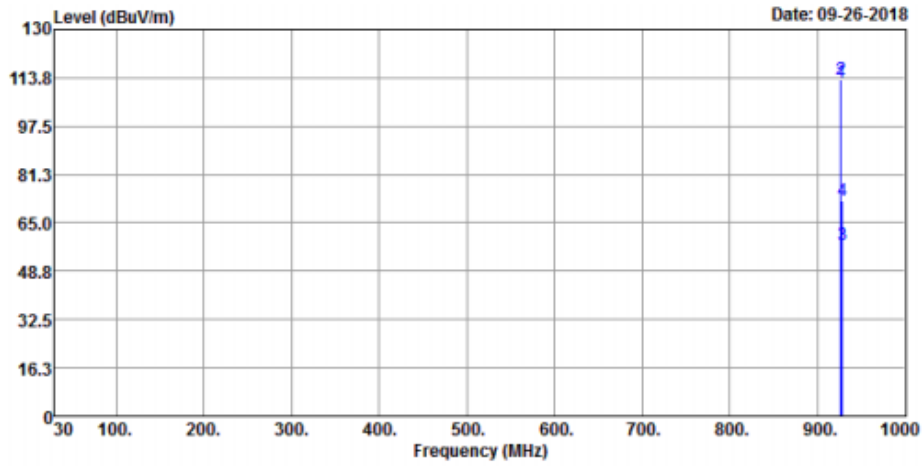

**Vertical**

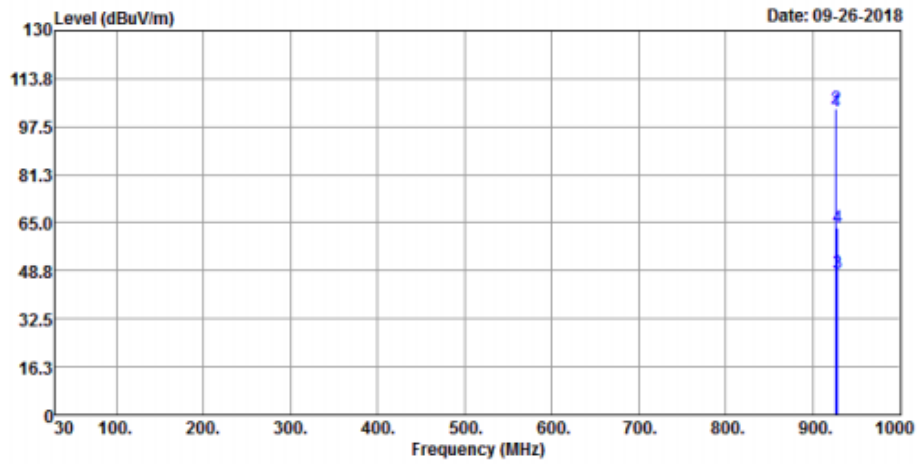

**Antenna Polarity & Test Distance: Horizontal at 3 m**

Frequency (MHz)	Emission Level (dBuV/m)	Read Level (dBuV)	Limit (dBuV/m)	Margin (dB)	Antenna Factor (dB/m)	Cable Loss (dB)	Preamp Factor (dB)	Antenna Height (cm)	Table Angle (Degree)	Remark
927	112.12	116.3	-----	-----	23.66	4.15	31.99	152	143	Average
927	113.22	117.4	-----	-----	23.66	4.15	31.99	152	143	QP
*928	57.44	61.6	92.12	-34.68	23.67	4.16	31.99	152	143	Average
*928	72.34	76.5	93.22	-20.88	23.67	4.16	31.99	152	143	QP

**Antenna Polarity & Test Distance: Vertical at 3 m**

Frequency (MHz)	Emission Level (dBuV/m)	Read Level (dBuV)	Limit (dBuV/m)	Margin (dB)	Antenna Factor (dB/m)	Cable Loss (dB)	Preamp Factor (dB)	Antenna Height (cm)	Table Angle (Degree)	Remark
927	102.62	106.8	-----	-----	23.66	4.15	31.99	101	242	Average
927	103.73	107.91	-----	-----	23.66	4.15	31.99	101	242	QP
*928	48.04	52.2	82.62	-34.58	23.67	4.16	31.99	101	242	Average
*928	63.1	67.26	83.73	-20.63	23.67	4.16	31.99	101	242	QP

## Remarks:

- Emission Level = Read Level + Antenna Factor + Cable Loss - Preamp Factor  
Margin value = Emission level – Limit value
- The emission levels of other frequencies were very low against the limit.
- \*: Out of Restricted Band

## 4.2 6 dB Bandwidth Measurement

### 4.2.1 Limits of 6 dB Bandwidth Measurement

The minimum of 6 dB Bandwidth Measurement is 0.5 MHz.

### 4.2.2 Test Setup

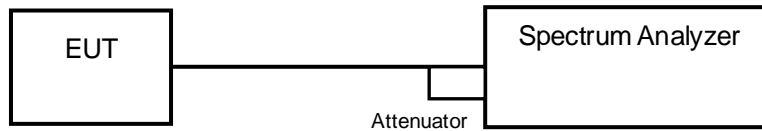

### 4.2.3 Test Instruments

Refer to section 4.1.2 to get information of above instrument.

### 4.2.4 Test Procedure

- Set resolution bandwidth (RBW) = 100 kHz
- Set the video bandwidth (VBW)  $\geq 3 \times$  RBW, Detector = Peak.
- Trace mode = max hold.
- Sweep = auto couple.
- Measure the maximum width of the emission that is constrained by the frequencies associated with the two amplitude points (upper and lower) that are attenuated by 6 dB relative to the maximum level measured in the fundamental emission

### 4.2.5 Deviation from Test Standard

No deviation.

### 4.2.6 EUT Operating Conditions

The software provided by client to enable the EUT under transmission condition continuously at lowest, middle and highest channel frequencies individually.

4.2.7 Test Results

Channel	Frequency (MHz)	6 dB Bandwidth (MHz)	Minimum Limit (MHz)	Pass / Fail
1	903	0.55	0.5	Pass
13	915	0.55	0.5	Pass
25	927	0.55	0.5	Pass

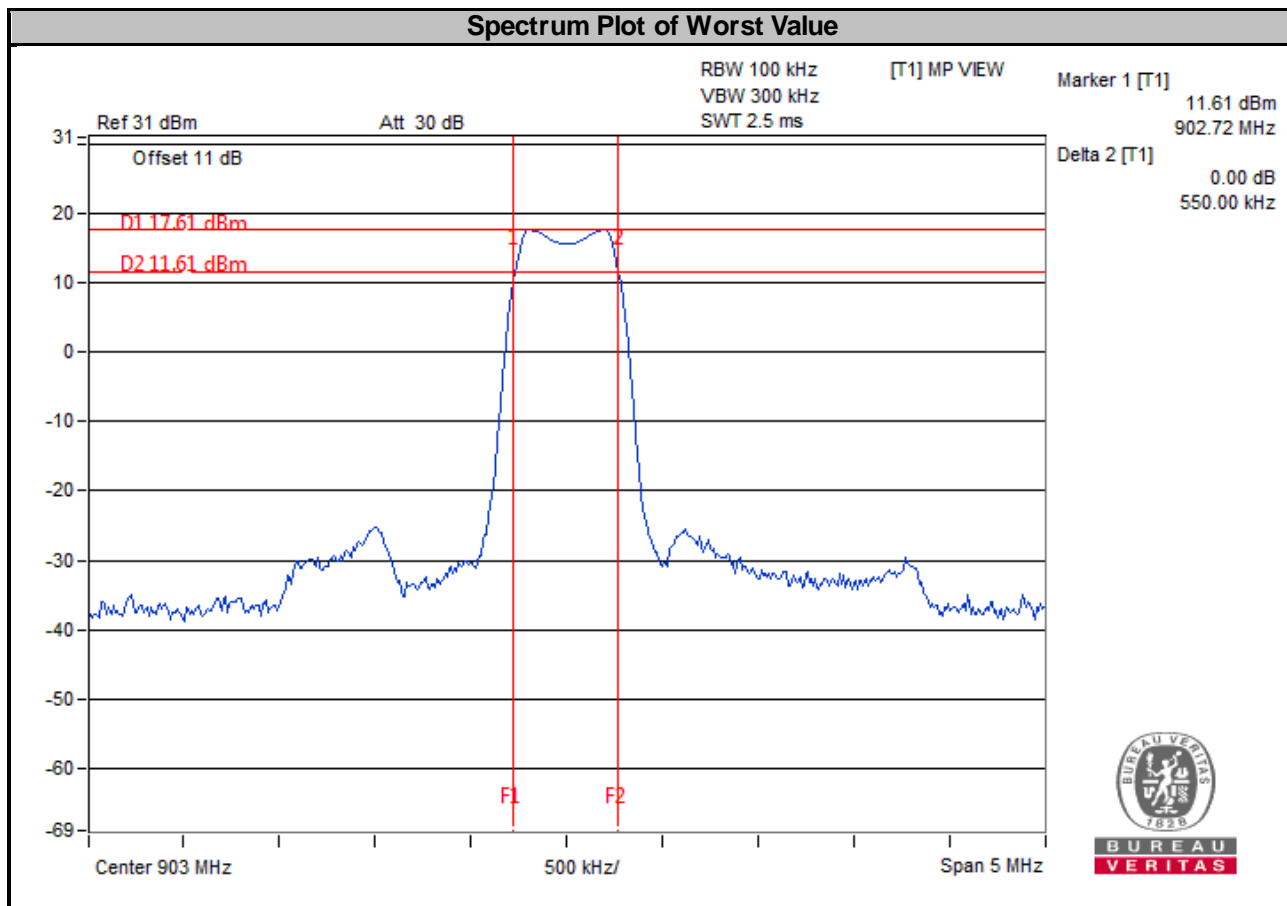



### 4.3 Occupied Bandwidth Measurement

#### 4.3.1 Test Setup

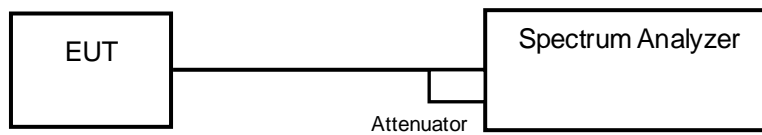

#### 4.3.2 Test Instruments

Refer to section 4.1.2 to get information of above instrument.

#### 4.3.3 Test Procedure

The transmitter output was connected to the spectrum analyzer through an attenuator. The bandwidth of the fundamental frequency was measured by spectrum analyzer with resolution bandwidth in the range of 1 % to 5 % of the anticipated emission bandwidth, and a video bandwidth at least 3x the resolution bandwidth and set the detector to PEAK. The width of a frequency band such that, below the lower and above the upper frequency limits, the mean powers emitted are each equal to a specified percentage 0.5 % of the total mean power of a given emission.

#### 4.3.4 Deviation from Test Standard

No deviation.

#### 4.3.5 EUT Operating Conditions

The software provided by client to enable the EUT under transmission condition continuously at lowest, middle and highest channel frequencies individually.

4.3.6 Test Results

Channel	Frequency (MHz)	Occupied Bandwidth (MHz)	Pass / Fail
1	903	0.46	Pass
13	915	0.46	Pass
25	927	0.46	Pass

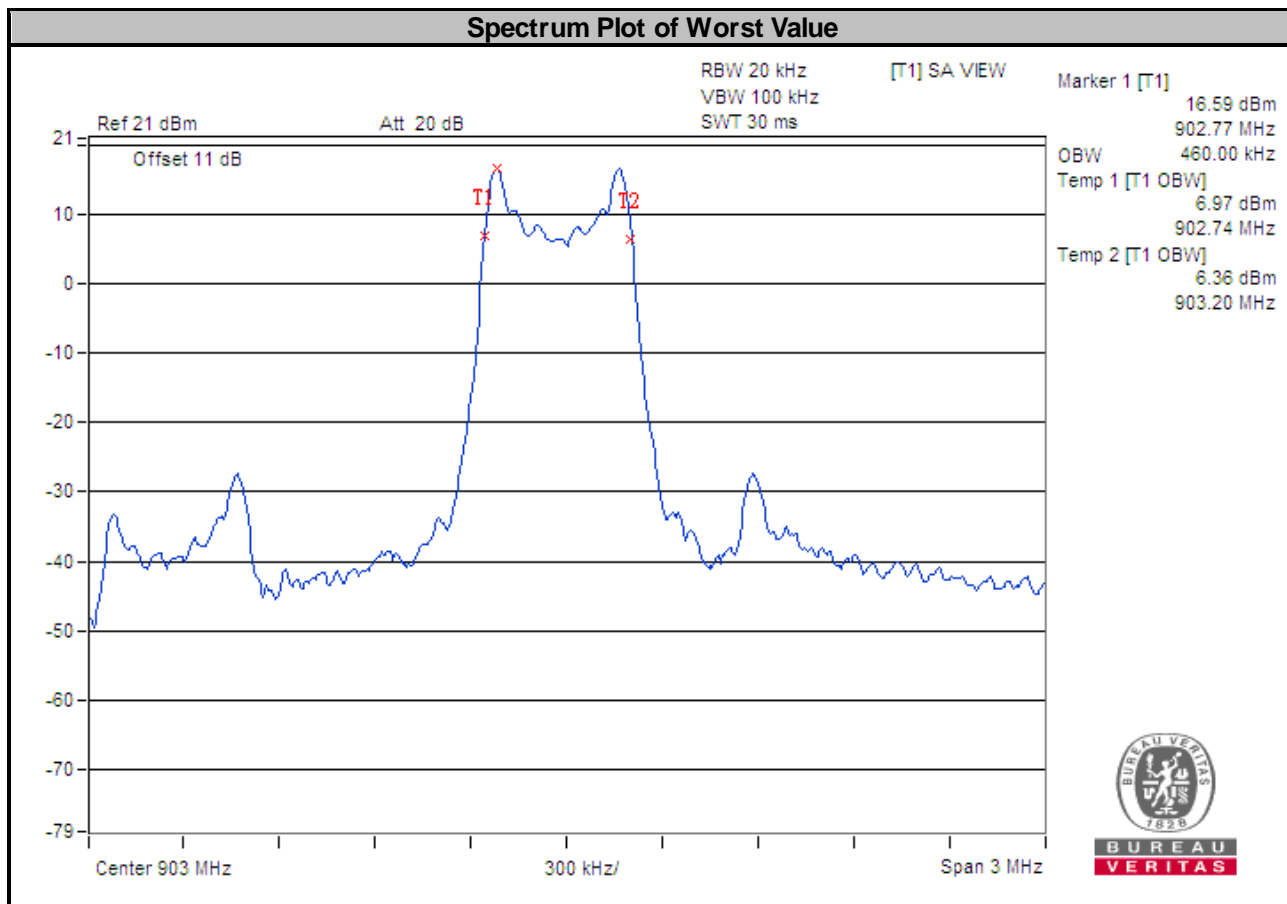

#### 4.4 Conducted Output Power Measurement

##### 4.4.1 Limits of Conducted Output Power Measurement

For systems using digital modulation in the 902-928 MHz bands: 1 Watt (30 dBm)

##### 4.4.2 Test Setup

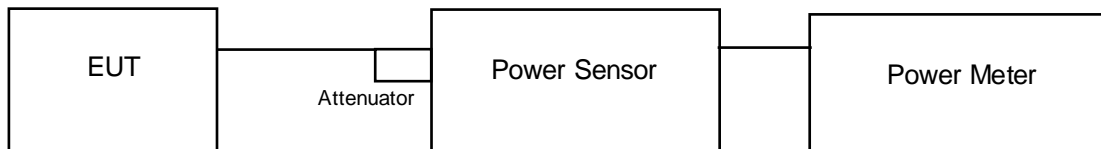

##### 4.4.3 Test Instruments

Refer to section 4.1.2 to get information of above instrument.

##### 4.4.4 Test Procedures

Average power sensor was used to perform output power measurement, trigger and gating function of wide band power meter is enabled to measure max output power of TX on burst. Duty factor is not added to measured value.

##### 4.4.5 Deviation from Test Standard

No deviation.

##### 4.4.6 EUT Operating Conditions

The software provided by client to enable the EUT under transmission condition continuously at lowest, middle and highest channel frequencies individually.

#### 4.4.7 Test Results

##### Main Module

Channel	Frequency (MHz)	Average Power (mW)	Average Power (dBm)	Limit (dBm)	Pass / Fail
<b>500 kbps</b>					
1	903	53.703	17.30	30	Pass
13	915	67.608	18.30	30	Pass
25	927	66.527	18.23	30	Pass
<b>150 kbps</b>					
1	903	65.615	18.17	30	Pass
13	915	65.464	18.16	30	Pass
25	927	64.269	18.08	30	Pass
<b>50 kbps</b>					
1	903	65.464	18.16	30	Pass
13	915	68.077	18.33	30	Pass
25	927	64.121	18.07	30	Pass

##### Secondary Module

Channel	Frequency (MHz)	Average Power (mW)	Average Power (dBm)	Limit (dBm)	Pass / Fail
<b>500 kbps</b>					
1	903	40.087	16.03	30	Pass
13	915	39.994	16.02	30	Pass
25	927	39.446	15.96	30	Pass
<b>150 kbps</b>					
1	903	39.902	16.01	30	Pass
13	915	39.446	15.96	30	Pass
25	927	38.815	15.89	30	Pass
<b>50 kbps</b>					
1	903	40.179	16.04	30	Pass
13	915	39.537	15.97	30	Pass
25	927	38.905	15.90	30	Pass

## 4.5 Power Spectral Density Measurement

### 4.5.1 Limits of Power Spectral Density Measurement

The Maximum of Power Spectral Density Measurement is 8 dBm.

### 4.5.2 Test Setup

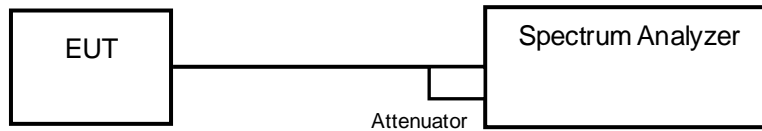

### 4.5.3 Test Instruments

Refer to section 4.1.2 to get information of above instrument.

### 4.5.4 Test Procedure

- a. Set analyzer center frequency to DTS channel center frequency.
- b. Set the span to 1.5 times the DTS bandwidth.
- c. Set the RBW to:  $3 \text{ kHz} \leq \text{RBW} \leq 100 \text{ kHz}$ .
- d. Set the VBW  $\geq 3 \times \text{RBW}$ .
- e. Detector = peak.
- f. Sweep time = auto couple.
- g. Trace mode = max hold.
- h. Allow trace to fully stabilize.
- i. Use the peak marker function to determine the maximum amplitude level within the RBW.

### 4.5.5 Deviation from Test Standard

No deviation.

### 4.5.6 EUT Operating Condition

The software provided by client to enable the EUT under transmission condition continuously at lowest, middle and highest channel frequencies individually.

4.5.7 Test Results

Channel	Frequency (MHz)	PSD (dBm/3 kHz)	Limit (dBm/3 kHz)	Pass / Fail
1	903	4.73	8	Pass
13	915	4.61	8	Pass
25	927	4.55	8	Pass

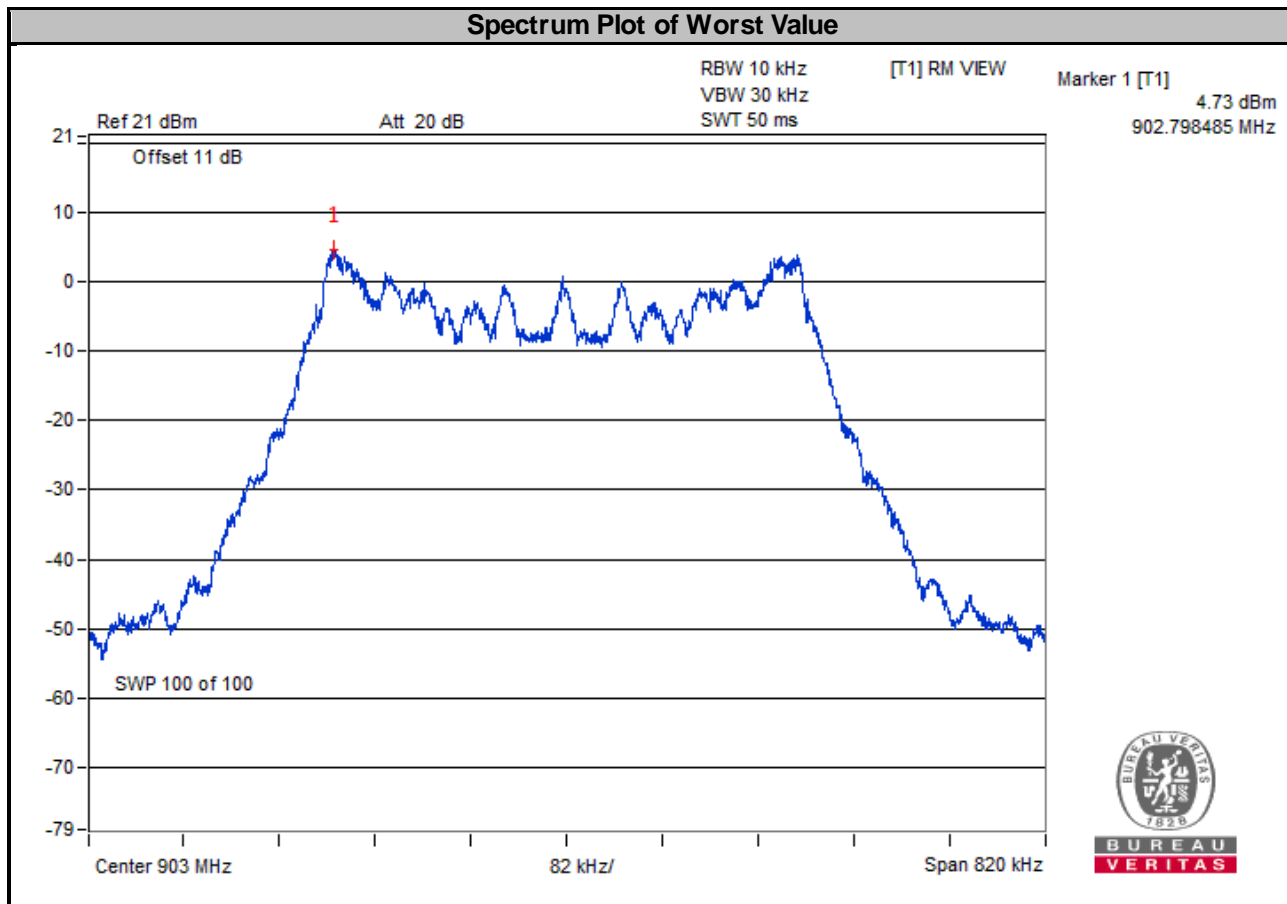

## 4.6 Conducted Out of Band Emission Measurement

### 4.6.1 Limits of Conducted Out of Band Emission Measurement

Below  $-30$  dB of the highest emission level of operating band (in 100 kHz Resolution Bandwidth).

### 4.6.2 Test Setup

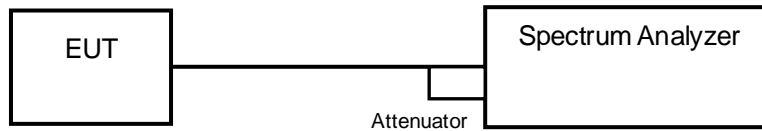

### 4.6.3 Test Instruments

Refer to section 4.1.2 to get information of above instrument.

### 4.6.4 Test Procedure

#### MEASUREMENT PROCEDURE REF

1. Set the RBW = 100 kHz.
2. Set the VBW  $\geq$  300 kHz.
3. Detector = peak.
4. Sweep time = auto couple.
5. Trace mode = max hold.
6. Allow trace to fully stabilize.
7. Use the peak marker function to determine the maximum power level in any 100 kHz band segment within the fundamental EBW.

#### MEASUREMENT PROCEDURE OOB

1. Set RBW = 100 kHz.
2. Set VBW  $\geq$  300 kHz.
3. Detector = peak.
4. Sweep = auto couple.
5. Trace Mode = max hold.
6. Allow trace to fully stabilize.
7. Use the peak marker function to determine the maximum amplitude level.

### 4.6.5 Deviation from Test Standard

No deviation.

### 4.6.6 EUT Operating Condition

The software provided by client to enable the EUT under transmission condition continuously at lowest, middle and highest channel frequencies individually.

### 4.6.7 Test Results

The spectrum plots are attached on the following pages. D1 line indicates the highest level, and D2 line indicates the 30dB offset below D1. It shows compliance with the requirement.

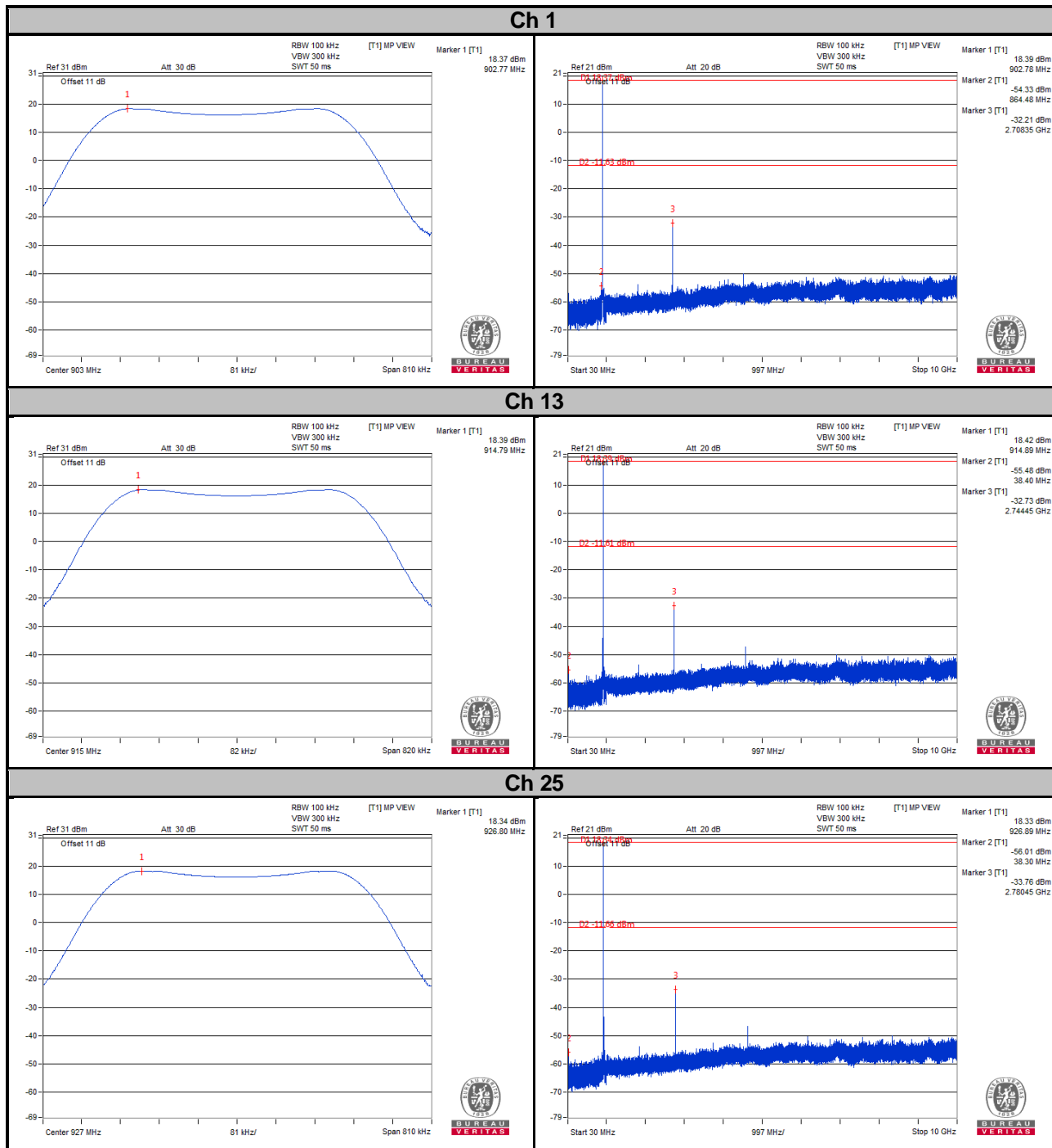



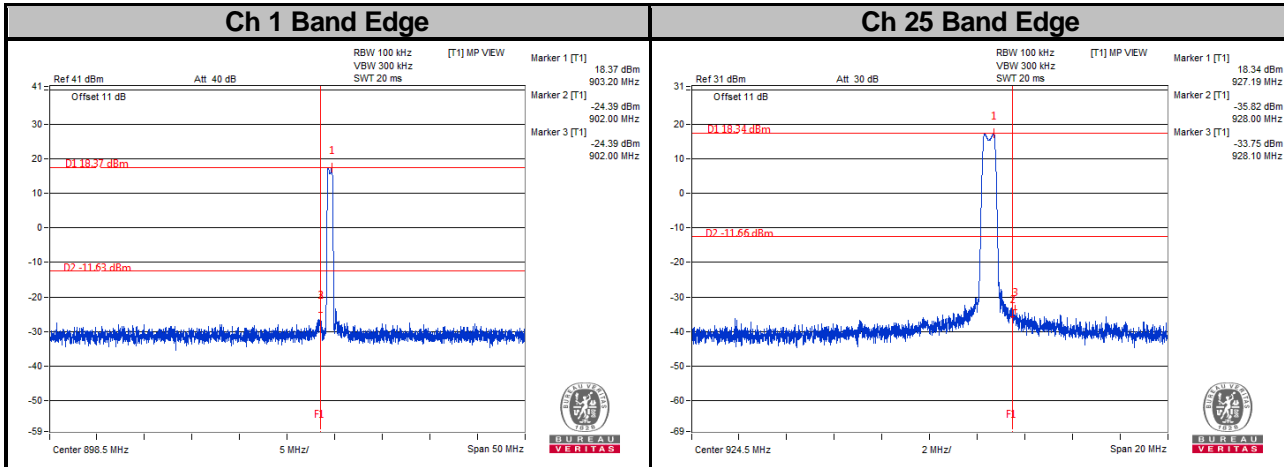

## 5 Pictures of Test Arrangements

Please refer to the attached file (Test Setup Photo).

## Appendix – Information on the Testing Laboratories

We, Bureau Veritas Consumer Products Services (H.K.) Ltd., Taoyuan Branch, were founded in 1988 to provide our best service in EMC, Radio, Telecom and Safety consultation. Our laboratories are FCC recognized accredited test firms and accredited according to ISO/IEC 17025.

If you have any comments, please feel free to contact us at the following:

**Linko EMC/RF Lab**

Tel: 886-2-26052180

Fax: 886-2-26051924

**Hsin Chu EMC/RF/Telecom Lab**

Tel: 886-3-6668565

Fax: 886-3-6668323

**Hwa Ya EMC/RF/Safety**

Tel: 886-3-3183232

Fax: 886-3-3270892

**Email:** [service.adt@tw.bureauveritas.com](mailto:service.adt@tw.bureauveritas.com)

**Web Site:** [www.bureauveritas-adt.com](http://www.bureauveritas-adt.com)

The address and road map of all our labs can be found in our web site also.

--- END ---