

# PCTEST Engineering Laboratory, Inc.

6660-B Dobbin Road • Columbia, MD 21045 • U.S.A.

TEL (410) 290-6652 • FAX (410) 290-6654

<http://www.pctestlab.com>



## CERTIFICATE OF COMPLIANCE (Type Acceptance)

SONY Personal & Mobile Communications of America  
16450 West Bernardo Drive  
San Diego, CA 92127-1804  
Attention: Glen Seebruch, Regulatory Engineer

Dates of Tests: May 26-29, 1998  
Test Report S/N: 22.980526375.L5A  
Test Site: PCTEST Lab, Columbia MD

FCC ID

**L5ACMZ200DM**

APPLICANT

**SONY ELECTRONICS INC.**

Classification: Non-Broadcast Transmitter held to ear (TNE)  
FCC Rule Part(s): §§§§22(E), 2.983, 2.987  
EUT Type: Dual Mode Portable Cellular Phone (AMPS/CDMA)  
Trade Name/Model(s): **SONY CM-Z200**  
Tx Frequency Range: 824.02 ~ 848.98MHz  
Rx Frequency Range: 869.04 ~ 893.97MHz  
Max Output Power: 0.6 W (AMPS) / 0.2 W (CDMA)  
Frequency Tolerance: 0.00025% (2.5 ppm)

This equipment has been shown to be capable of compliance with the applicable technical standards as indicated in the measurement report and was tested in accordance with the measurement procedures specified in §2.947 with the following remarks (Note Codes):

*\* (BC) The output power is continuously variable from the value listed in this entry to 5%-10% of the value listed.*

I attest to the accuracy of data. All measurements reported herein were performed by me or were made under my supervision and are correct to the best of my knowledge and belief. I assume full responsibility for the completeness of these measurements and vouch for the qualifications of all persons taking them.

*PCTEST certifies that no party to this application has been denied the FCC benefits pursuant to Section 5301 of the Anti-Drug Abuse Act of 1988, 21 U.S.C. 853(a)*

  
Randy Ortanez  
President & Chief Engineer



9 8 0 5 2 6 3 7 6 . L 5 A

**NVLAQ**<sup>®</sup>  
LAB CODE 100431-0

## TABLE OF CONTENTS

---

ATTACHMENT A:	COVER LETTER(S)	
ATTACHMENT B:	ATTESTATION STATEMENT(S)	
ATTACHMENT C:	TEST REPORT	
	SCOPE	1
	INTRODUCTION	2
	DESCRIPTION OF TESTS	3-6
	EFFECTIVE RADIATED POWER OUTPUT	7-8
	RADIATED MEASUREMENTS	9-14
	FREQUENCY STABILITY	15
	PLOTS OF EMISSIONS	16
	LIST OF TEST EQUIPMENT	17
	SAMPLE CALCULATIONS	18
	RECOMMENDATION / CONCLUSION	19
ATTACHMENT D:	TEST PLOTS	
ATTACHMENT E:	FCC ID LABEL / LOCATION	
ATTACHMENT F:	TEST SETUP PHOTOGRAPHS	
ATTACHMENT G:	EXTERNAL PHOTOGRAPHS	
ATTACHMENT H:	INTERNAL PHOTOGRAPHS	
ATTACHMENT I:	BLOCK DIAGRAM(S)	
ATTACHMENT J:	SCHEMATIC DIAGRAMS(S)	
ATTACHMENT K:	OPERATIONAL DESCRIPTION	
ATTACHMENT L:	PARTS LIST/TUNE UP PROCEDURE	
ATTACHMENT M:	USER'S MANUAL	
ATTACHMENT N:	SAR MEASUREMENT REPORT	
ATTACHMENT O:	SAR TEST DATA	
ATTACHMENT P:	SAR TEST SETUP PHOTOGRAPHS	

# MEASUREMENT REPORT

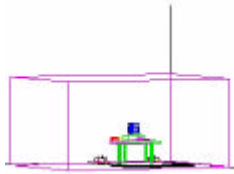

Scope - Measurement and determination of electromagnetic emissions (EME) of radio frequency devices including intentional and/or unintentional radiators for compliance with the technical rules and regulations of the Federal Communications Commission.

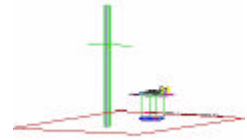

## §2983(a) General Information

<b>Applicant Name:</b>	<b>SONY Electronics Inc. Personal &amp; Mobile Communications of America</b>
<b>Address:</b>	<b>16450 West Bernardo Drive San Diego, CA 92127-1804</b>
<b>Attention:</b>	<b>Glen Seebruch, Regulatory Engineer</b>

- §2983(b) FCC ID: **L5ACMZ200DM**
- §2983(c) Quantity: Quantity production is planned
- §2.983(d) Emission Designator: 40K0F8W, 40K0F1D, 1M25F9W
- §2.983(d) Tx Freq. Range: 824.02 – 848.98 MHz  
Rx Freq. Range: 869.04 – 893.97 MHz
- Equipment Class: Non-Broadcast Transmitter Held to Ear (TNE)
- Equipment Type: Dual Mode Portable Cellular Phone
- Modulation: AMPS/CDMA
- Frequency Tolerance:  $\pm 0.00025\%$  (2.5 ppm)
- §2.983(d) Max. Power: 0.6W (AMPS) / 0.2W (CDMA)
- FCC Rule Part(s): §§§§ 22(E), 2.983, 2.987
- AC/DC Charger: 110-220VAC, 60Hz (Model: QN-032AC)
- §2.983(d) D.C. Voltage into Final RF Amplifier: 7.2 VDC
- Dates of Tests: May 26-29, 1998
- Place of Tests: PCTEST Lab, Columbia, MD U.S.A.

## 1.1 INTRODUCTION

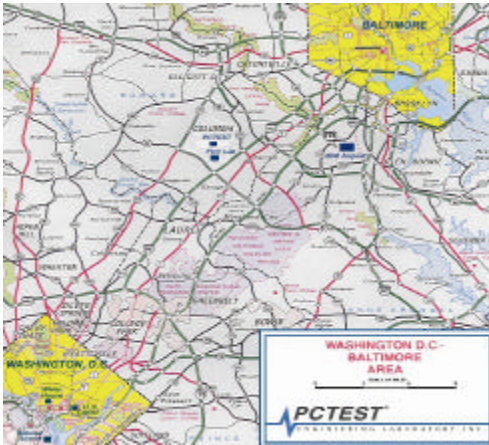
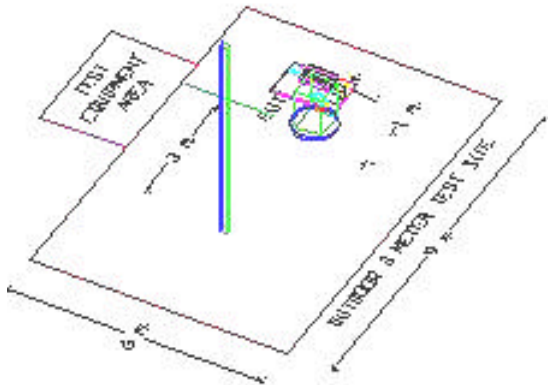

Figure 1. Map of the Greater Baltimore and Metropolitan Washington, D.C. area.

These measurement tests were conducted at **PCTEST Engineering Laboratory, Inc.** facility in New Concept Business Park, Guilford Industrial Park, Columbia, Maryland. The site address is 6660-B Dobbin Road, Columbia, MD 21045. The test site is one of the highest points in the Columbia area with an elevation of 390 feet above mean sea level. The site coordinates are 39° 11'15" N latitude and 76° 49'38" W longitude. The facility is 1.5 miles North of the FCC laboratory, and the ambient signal and ambient signal strength are approximately equal to those of the FCC laboratory. There are no FM or TV transmitters within 15 miles of the site. The detailed description of the measurement facility was found to be in compliance with the requirements of § 2.948 according to ANSI C63.4 on October 19, 1992.

### Measurement Procedure

The radiated and spurious measurements were made outdoors at 3-meter test range (see Figure 2). The equipment under test is placed on the turntable connected to a RF wattmeter and a dummy RF load, and then its power is adjusted to its rated output. A receiving antenna located 2 meters from the turntable picks up any signal radiated from the transmitter. The turntable containing the system was rotated; the receiving antenna height was varied 1 to 4 meters and stopped at the azimuth or height producing the maximum emission. The testing procedure is repeated for both horizontal and vertical polarization of the receiving antenna. The actual radiated signal strength is obtained by substitution method with a signal generator with a calibrated output. The signal generator is adjusted in output until its reading is identical to that obtained when the receiving antenna is connected to the receiver. Signal strength is then read directly from the signal generator.



## **2.1 INSERTS PER §2.983(d)**

---

### **§2.983(d) Function of Active Devices**

The Function of active devices are shown in Attachment M.

### **§2.983(d) Circuit Diagrams & Description (Confidential)**

The circuit diagrams & description, schematics, and block diagram are shown in Attachment J.

### **§2.983(d) Operating Instructions**

The instruction manual is shown in Attachment M.

### **§2.983(d) Tune-Up Procedure**

The tune-up procedure is shown in Attachment K.

### **§2.983(d) Description of Freq. Stabilization Circuit**

The description of frequency stabilization circuit is shown in Attachment L.

### **§2.983(d) Description for Suppression of Spurious Radiation, for Limiting Modulation, and Harmonic Suppresion Circuits**

The description of suppression stabilization circuits are shown in Attachment M.

### **§2.985 (a)(c) RF Power Output (Analog Mode)**

The RF output power is measured via HP436A Power Meter and Sensor.  
Supply voltage: 7.2 VDC 600 mAh

Channel No.	Nominal Freq. (MHz)	Power Output (Watts)	
		Hi	Low
991	824.04	0.60	0.006
383	836.49	0.60	0.006
799	848.97	0.60	0.006

Table 1. RF Power Output Data (Program Selectable).

### 3.1 DESCRIPTION OF TESTS

---

#### 3.2 §2.987(a) Transmitter Audio Frequency Response

The frequency response of the audio modulating circuit over the frequency range 100 – 5000 Hz is measured. The audio signal generator is connected to the audio input circuit/microphone of the EUT. The audio signal input is adjusted to obtain 50% modulation at 1kHz and this point is taken as the 0dB reference. With the input held constant and below the limit at all frequencies, the audio signal generator is varied from 100 to 50 kHz. The response in dB relative to 1kHz is measured using the HP8901 a Modulation Analyzer. For the frequency response of the audio low-pass filter, the audio input is connected at the input to the modulation limiter and the modulated stage. The audio output is connected at the output of the modulated stage. The corresponding plots are shown herein

#### 3.3 §2.987(b) Modulation Limiting.

The audio signal generator is connected to the audio input circuit/microphone of the EUT. The modulation response is measured for each of the three modulating frequencies (300Hz, 1000 Hz, and 2990Hz), and the input voltage is varied from 30% modulation ( $\pm 3.6$ kHz deviation) to at least 20dB higher than the saturation point. Measurements of modulation and the plots are attached herein.

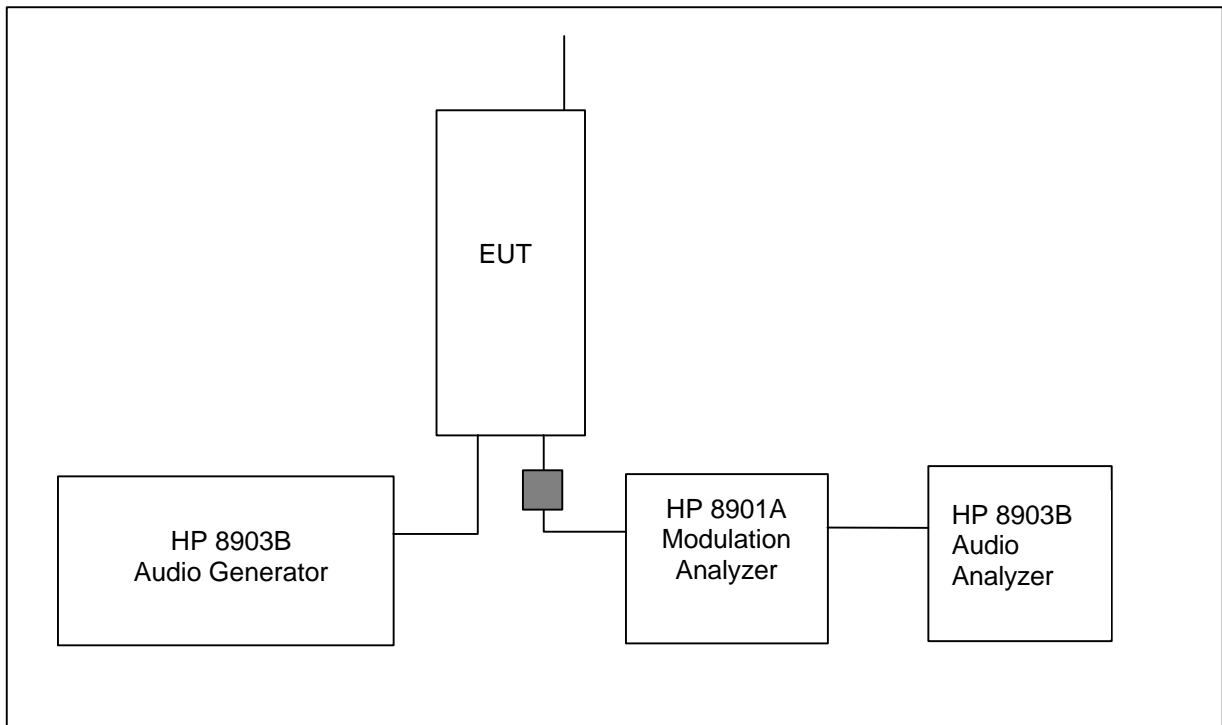

Fig. 3. Transmitter Audio Freq. Test Setup

### **3.1 DESCRIPTION OF TESTS (CONTINUED)**

---

#### **3.4 §2.989(c) Occupied Bandwidth**

The audio signal generator is adjusted to 1kHz. The output level is set to +/- 6kHz deviation. With the level constant, the freq. is set to 2,500Hz. Then the audio signal level is increased by 16dB. The occupied bandwidth data is obtained for the SAT (Supervisory Audio Tone), ST (Signaling Tone), WBD (Wideband Data), and DTMF (Dual Tone Multi Frequencies). The results are shown on the attached graphs.

Specified Limits:

- (a) On any frequency removed from the assigned carrier frequency by more than 20kHz, up to and including 45kHz, the sideband is at least 26dB below the carrier.
- (b) On any frequency removed from the assigned carrier frequency by more than 45kHz, up to and including 90kHz, the sideband is at least 45dB below the carrier.
- (c) On any frequency removed from the assigned carrier frequency by more than 90kHz, up to the first multiple of the carrier frequency, the sideband is at least 60dB below the carrier of  $40 + \log_{10}$  (mean power output in Watts) dB, whichever is the smaller attenuation.

#### **3.5 §2.991 Spurious and Harmonic Emissions at Antenna Terminal**

The level of the carrier and the various conducted spurious and harmonic frequencies is measured by means of a calibrated spectrum analyzer. The spectrum is scanned from the lowest frequency generated in the equipment up to 10 GHz. The transmitter is modulated with a 2500Hz tone at a level of 16dB greater than that required to provide 50% modulation.

At the input terminals of the spectrum analyzer, an isolator (RF circulator with one port terminated with 50 ohms) and an 870 MHz to 890 MHz bandpass filter is connected between the test transceiver (for conducted tests) or the receive antenna (for radiated tests) and the analyzer. The rejection of the bandpass filter to signals in the 825 – 845 MHz range is adequate to limit the transmit energy from the test transceiver which appears to a level which will allow the analyzer to measure signals less than -90dBm. Calibration of the test receiver is performed in the 870 – 890 MHz range to insure accuracy to allow variation in the passband filter insertion loss to be calibrated.

#### **3.7 §2.993 Radiation Spurious and Harmonic Emissions**

Radiation and harmonic emissions above 1 GHz is measured at our 3-meter indoor site. The EUT is placed on the turntable connected to a dummy load in normal operation using the intended power source. A receiving antenna located 3 meters from the turntable receives any signal radiated from the transmitter and its operating accessories. The antenna is varied from 1 to 4 meters and the polarization is varied (horizontal and vertical) to determine the worst-case emission level. To obtain actual radiated signal strength, a signal generator is adjusted in output until a reading identical to that obtained with the actual transmitter is obtained at the receiver. Signal strength is read directly from the generator and recorded on the attached table.

### 3.1 DESCRIPTION OF TESTS (CONTINUED)

---

#### **3.8 §24.135 Frequency Stability/Temperature Variation**

The frequency stability of the transmitter is measured by:

- a.) **Temperature:** The temperature is varied from -30°C to +60°C using an environmental chamber.
- b.) **Primary Supply Voltage:** The primary supply voltage is varied from 85% to 115% of the voltage normally at the input to the device or at the power supply terminals if cables are not normally supplied.

*Specification – The minimum frequency stability shall be +/- 0.00025% at any time during normal operation.*

**Time Period and Procedure:**

1. The carrier frequency of the transmitter and the individual oscillators is measured at room temperature (25°C to 27°C to provide a reference).
2. The equipment is subjected to an overnight “soak” at -30°C without any power applied.
3. After the overnight “soak” at 30°C (usually 14-16 hours), the equipment is turned on in a “standby” condition for one minute before applying power to the transmitter. Measurement of the carrier frequency of the transmitter and the individual oscillators is made within a three minute interval after applying power to the transmitter.
4. Frequency measurements is made at 10°C interval up to room temperature. At least a period of one and one half hour is provided to allow stabilization of the equipment at each temperature level.
5. Again the transmitter carrier frequency and the individual oscillators is measured at room temperature to begin measurement of the upper temperature levels.
6. Frequency were made at 10 intervals starting at 30°C up to +50°C allowing at least two hours at each temperature for stabilization. In all measurements the frequency is measured within three minutes after applying power to the transmitter.
7. The artificial load is mounted external to the temperature chamber.

**NOTE: The EUT is tested down to the battery endpoint.**



## Test Data

### § 22.913 Effective Radiated Power Output

A. POWER: **Low (Analog Mode)**

Freq. Tuned (MHz)	LEVEL (dBm)	AFCL (dB)	POL (H/V)	F/S ( $\mu$ V/m)	ERP (W)	ERP (dBm)
824.04	-33.4	31.65	V	183031	0.00614	7.87
836.49	-33.6	31.81	V	182098	0.00608	7.83
848.97	-33.8	31.96	V	181178	0.00602	7.78

B. POWER: **High (Analog Mode)**

Freq. Tuned (MHz)	LEVEL (dBm)	AFCL (dB)	POL (H/V)	F/S ( $\mu$ V/m)	ERP (W)	ERP (dBm)
824.04	-12.8	31.65	V	1961214	0.70527	28.47
836.49	-13.0	31.81	V	1951220	0.69810	28.43
848.97	-13.2	31.96	V	1941361	0.69107	28.38

**NOTES:**

The EUT is placed 3m. away from the receiving antenna and the ERP

is calculated using the formula:

$$\text{ERP (dBm)} = 10 \text{ Log}_{10} \left( \frac{(r(\text{mV/m})/1 \times 10^6)^2}{49.2/1 \times 10^{-3}} \right)$$

$$\text{ERP (dBm)} = 10 \text{ Log}_{10} \left[ \frac{(3 \times \text{FS}/1 \times 10^6)^2}{(49.2) \times 1000} \right]$$

$$\text{ERP (Watts)} = \frac{(3 \times \text{FS})/1 \times 10^6)^2}{49.2}$$

## Test Data

---

### § 22.913 Effective Radiated Power Output

B. POWER: **High (CDMA Mode)**

Freq. Tuned (MHz)	LEVEL (dBm)	AFCL (dB)	POL (H/V)	F/S ( $\mu$ V/m)	ERP (W)	ERP (dBm)
824.64	-17.5	31.66	V	1142615	0.23939	23.78
835.89	-17.8	31.80	V	1121841	0.23076	23.62
848.37	-18.0	31.95	V	1116172	0.22844	23.58

**NOTES:**

The EUT is placed 3m. away from the receiving antenna and the ERP is calculated using the formula:

$$\text{ERP (dBm)} = 10 \text{ Log}_{10} \left( \frac{(r(\text{mV/m})/1 \times 10^6)^2}{49.2/1 \times 10^{-3}} \right)$$

$$\text{ERP (dBm)} = 10 \text{ Log}_{10} \left[ \frac{(3 \times \text{FS}/1 \times 10^6)^2}{(49.2) \times 1000} \right]$$

$$\text{ERP (Watts)} = \frac{(3 \times \text{FS})/1 \times 10^6}{49.2}$$

## Test Data

### Radiated Measurements

#### § 2.993 Field Strength of SPURIOUS Radiation (CDMA)

OPERATING FREQUENCY: 824.04 MHz  
 CHANNEL: 991 (Low)  
 MEASURED OUTPUT POWER: 23.00 dBm = 0.20 W  
 MODULATION SIGNAL: CDMA (Internal)  
 DISTANCE: 3 meters  
 LIMIT:  $43 + 10 \log_{10} (W) =$  36.01 dBc

FREQ. (MHz)	LEVEL (dBm)	AFCL (dB)	POL (H/V)	F/S ( $\mu$ V/m)	ERP (dBm)	(dBc)
1648.08	-86.0	34.5	V	595.7	-41.88	64.9
2472.12	-89.2	38.8	V	676.1	-40.78	63.8
3296.16	-93.8	42.5	V	609.5	-41.68	64.7
4120.20	-97.8	46.1	V	582.1	-42.08	65.1
4944.24	-107.0	48.0	V	251.2	-49.38	72.4

#### NOTES:

- The bandwidth is set per §24.238 (RBW = 1MHz, VBW = 1MHz).
- The spectrum was checked from 25 MHz up to the 10th harmonic.
- All emissions not listed were found to be more than 20dB below the limit.
- < -130dBm is below the floor of the spectrum analyzer.
- The EUT is manipulated through 3 orthogonal axis and the worst-case are reported.
- The EUT is placed 3m. away from the receiving antenna and the ERP is calculated using the formula:

$$\text{ERP (dBm)} = 10 \text{ Log}_{10} \{ ((r(\text{mV/m})/1 \times 10^6)^2 / 49.2/1 \times 10^{-3}) \}$$

$$\text{ERP (dBm)} = 10 \text{ Log}_{10} [ (3 \times \text{FS}/1 \times 10^6)^2 / (49.2) \times 1000 ]$$

$$\text{ERP (Watts)} = \{ (3 \times \text{FS})/1 \times 10^6 \}^2 / 49.2$$

## Test Data

### Radiated Measurements

#### § 2.993 Field Strength of SPURIOUS Radiation (CDMA)

OPERATING FREQUENCY: 836.49 MHz  
 CHANNEL: 383 (Middle)  
 MEASURED OUTPUT POWER: 23.00 dBm = 0.20 W  
 MODULATION SIGNAL: CDMA (Internal)  
 DISTANCE: 3 meters  
 LIMIT:  $43 + 10 \log_{10} (W) =$  36.01 dBc

FREQ. (MHz)	LEVEL (dBm)	AFCL (dB)	POL (H/V)	F/S ( $\mu$ V/m)	ERP (dBm)	(dBc)
1672.98	-85.8	34.5	V	609.5	-41.68	64.7
2509.47	-90.0	39.0	V	631.0	-41.38	64.4
3345.96	-95.0	42.7	V	543.3	-42.68	65.7
4182.45	-98.2	46.2	V	562.3	-42.38	65.4
5018.94	-106.5	48.5	V	281.8	-48.38	71.4

#### NOTES:

- The bandwidth is set per §24.238 (RBW = 1MHz, VBW = 1MHz).
- The spectrum was checked from 25 MHz up to the 10th harmonic.
- All emissions not listed were found to be more than 20dB below the limit.
- < -130dBm is below the floor of the spectrum analyzer.
- The EUT is manipulated through 3 orthogonal axis and the worst-case are reported.
- The EUT is placed 3m. away from the receiving antenna and the ERP is calculated using the formula:

$$\text{ERP (dBm)} = 10 \text{ Log}_{10} \{ ((r(\text{mV/m})/1 \times 10^6)^2 / 49.2/1 \times 10^{-3}) \}$$

$$\text{ERP (dBm)} = 10 \text{ Log}_{10} [ (3 \times \text{FS}/1 \times 10^6)^2 / (49.2) \times 1000 ]$$

$$\text{ERP (Watts)} = \{ (3 \times \text{FS})/1 \times 10^6 \}^2 / 49.2$$

## Test Data

### Radiated Measurements

#### § 2.993 Field Strength of SPURIOUS Radiation (CDMA)

OPERATING FREQUENCY: 848.97 MHz  
 CHANNEL: 799 (High)  
 MEASURED OUTPUT POWER: 23.00 dBm = 0.20 W  
 MODULATION SIGNAL: CDMA (Internal)  
 DISTANCE: 3 meters  
 LIMIT:  $43 + 10 \log_{10} (W) =$  36.01 dBc

FREQ. (MHz)	LEVEL (dBm)	AFCL (dB)	POL (H/V)	F/S ( $\mu$ V/m)	ERP (dBm)	(dBc)
1697.94	-87.0	34.9	V	555.9	-42.48	65.5
2546.91	-90.2	39.2	V	631.0	-41.38	64.4
3395.88	-94.5	42.9	V	588.8	-41.98	65.0
4244.85	-97.8	46.1	V	582.1	-42.08	65.1
5093.82	-107.0	48.4	V	263.0	-48.98	72.0

#### NOTES:

- The bandwidth is set per §24.238 (RBW = 1MHz, VBW = 1MHz).
- The spectrum was checked from 25 MHz up to the 10th harmonic.
- All emissions not listed were found to be more than 20dB below the limit.
- < -130dBm is below the floor of the spectrum analyzer.
- The EUT is manipulated through 3 orthogonal axis and the worst-case are reported.
- The EUT is placed 3m. away from the receiving antenna and the ERP is calculated using the formula:

$$\text{ERP (dBm)} = 10 \text{ Log}_{10} \{ ((r(\text{mV/m})/1 \times 10^6)^2 / 49.2/1 \times 10^{-3}) \}$$

$$\text{ERP (dBm)} = 10 \text{ Log}_{10} [ (3 \times \text{FS}/1 \times 10^6)^2 / (49.2) \times 1000 ]$$

$$\text{ERP (Watts)} = \{ (3 \times \text{FS})/1 \times 10^6 \}^2 / 49.2$$

## Test Data

### Radiated Measurements

#### § 2.993 Field Strength of SPURIOUS Radiation (Analog)

OPERATING FREQUENCY: 824.04 MHz  
 CHANNEL: 991 (Low)  
 MEASURED OUTPUT POWER: 27.80 dBm = 0.60 W  
 MODULATION SIGNAL: ST (Signalling Tone)  
 DISTANCE: 3 meters  
 LIMIT:  $43 + 10 \log_{10} (W) =$  40.81 dBc

FREQ. (MHz)	LEVEL (dBm)	AFCL (dB)	POL (H/V)	F/S ( $\mu$ V/m)	ERP (dBm)	(dBc)
1648.08	-83.0	34.5	V	841.4	-38.88	66.7
2472.12	-87.5	38.8	V	822.2	-39.08	66.9
3296.16	-91.0	42.5	V	841.4	-38.88	66.7
4120.20	-96.2	46.1	V	699.8	-40.48	68.3
4944.24	-103.0	48.0	V	398.1	-45.38	73.2

#### NOTES:

- The bandwidth is set per §22.917 (RBW = 1MHz, VBW = 1MHz).
- The spectrum was checked from 25 MHz up to the 10th harmonic.
- All emissions not listed were found to be more than 20dB below the limit.
- < -130dBm is below the floor of the spectrum analyzer.
- The EUT is manipulated through 3 orthogonal axis and the worst-case are reported.
- The EUT is placed 3m. away from the receiving antenna and the ERP is calculated using the formula:  

$$\text{ERP (dBm)} = 10 \text{ Log}_{10} \left( \frac{(3 \times \text{FS})^2}{49.2} \times 10^{-3} \right)$$

$$\text{ERP (dBm)} = 10 \text{ Log}_{10} [ (3 \times \text{FS})^2 / (49.2) \times 1000 ]$$

$$\text{ERP (Watts)} = \frac{(3 \times \text{FS})^2}{49.2}$$

## Test Data

### Radiated Measurements

#### § 2.993 Field Strength of SPURIOUS Radiation (Analog)

OPERATING FREQUENCY: 836.49 MHz  
 CHANNEL: 383 (Middle)  
 MEASURED OUTPUT POWER: 27.80 dBm = 0.60 W  
 MODULATION SIGNAL: ST (Signalling Tone)  
 DISTANCE: 3 meters  
 LIMIT:  $43 + 10 \log_{10} (W) =$  40.81 dBc

FREQ. (MHz)	LEVEL (dBm)	AFCL (dB)	POL (H/V)	F/S ( $\mu$ V/m)	ERP (dBm)	(dBc)
1672.98	-84.0	34.5	V	749.9	-39.88	67.7
2509.47	-88.2	39.0	V	776.2	-39.58	67.4
3345.96	-92.0	42.7	V	767.4	-39.68	67.5
4182.45	-97.5	46.2	V	609.5	-41.68	69.5
5018.94	-104.8	48.5	V	342.8	-46.68	74.5

#### NOTES:

- The bandwidth is set per §22.917 (RBW = 1MHz, VBW = 1MHz).
- The spectrum was checked from 25 MHz up to the 10th harmonic.
- All emissions not listed were found to be more than 20dB below the limit.
- < -130dBm is below the floor of the spectrum analyzer.
- The EUT is manipulated through 3 orthogonal axis and the worst-case are reported.
- The EUT is placed 3m. away from the receiving antenna and the ERP is calculated using the formula:  

$$\text{ERP (dBm)} = 10 \text{ Log}_{10} \left( \frac{(r(\text{mV/m})/1 \times 10^6)^2}{49.2/1 \times 10^{-3}} \right)$$

$$\text{ERP (dBm)} = 10 \text{ Log}_{10} \left[ \frac{(3 \times \text{FS}/1 \times 10^6)^2}{(49.2) \times 1000} \right]$$

$$\text{ERP (Watts)} = \frac{(3 \times \text{FS})/1 \times 10^6}{49.2}$$

## Test Data

### Radiated Measurements

#### § 2.993 Field Strength of SPURIOUS Radiation (Analog)

OPERATING FREQUENCY: 848.97 MHz  
 CHANNEL: 799 (High)  
 MEASURED OUTPUT POWER: 27.80 dBm = 0.60 W  
 MODULATION SIGNAL: ST (Signalling Tone)  
 DISTANCE: 3 meters  
 LIMIT:  $43 + 10 \log_{10} (W) =$  40.81 dBc

FREQ. (MHz)	LEVEL (dBm)	AFCL (dB)	POL (H/V)	F/S ( $\mu$ V/m)	ERP (dBm)	(dBc)
1697.94	-83.8	34.9	V	803.5	-39.28	67.1
2546.91	-89.5	39.2	V	683.9	-40.68	68.5
3395.88	-93.0	42.9	V	699.8	-40.48	68.3
4244.85	-97.0	46.1	V	638.3	-41.28	69.1
5093.82	-106.0	48.4	V	295.1	-47.98	75.8

#### NOTES:

- The bandwidth is set per §22.917 (RBW = 1MHz, VBW = 1MHz).
- The spectrum was checked from 25 MHz up to the 10th harmonic.
- All emissions not listed were found to be more than 20dB below the limit.
- < -130dBm is below the floor of the spectrum analyzer.
- The EUT is manipulated through 3 orthogonal axis and the worst-case are reported.
- The EUT is placed 3m. away from the receiving antenna and the ERP is calculated using the formula:  

$$\text{ERP (dBm)} = 10 \text{ Log}_{10} \left( \frac{(r(\text{mV/m})/1 \times 10^6)^2}{49.2/1 \times 10^{-3}} \right)$$

$$\text{ERP (dBm)} = 10 \text{ Log}_{10} \left[ \frac{(3 \times \text{FS}/1 \times 10^6)^2}{(49.2) \times 1000} \right]$$

$$\text{ERP (Watts)} = \frac{\{(3 \times \text{FS})/1 \times 10^6\}^2}{49.2}$$



## Test Data

### § 24.135 FREQUENCY STABILITY

OPERATING FREQUENCY: 836,490,010 Hz

CHANNEL: 383.0

REFERENCE VOLTAGE: 7.2 VDC

DEVIATION LIMIT: ± 0.00025 % or 2.5 ppm

VOLTAGE (%)	POWER (VDC)	TEMP (°C)	FREQ. (Hz)	Deviation (%)
100 %	7.20	+ 20 (Ref)	836,490,010	0.000000
100 %		- 30	836,491,348	-0.000160
100 %		- 20	836,491,097	-0.000130
100 %		- 10	836,490,846	-0.000100
100 %		0	836,490,679	-0.000080
100 %		+ 10	836,490,428	-0.000050
100 %		+ 20	836,490,010	0.000000
100 %		+ 25	836,489,508	0.000060
100 %		+ 30	836,489,257	0.000090
100 %		+ 40	836,489,174	0.000100
100 %		+ 50	836,488,755	0.000150
100 %		+ 60	836,488,504	0.000180
85 %		6.12	+ 20	836,490,010
115 %	8.28	+ 20	836,490,010	0.000000
BATT. ENDPOINT	5.70	+ 20	836,490,010	0.000000

## 5.1 PLOT(S) OF EMISSIONS

---

SEE ATTACHMENT D

## 6.1 TEST EQUIPMENT

6.2 Type	Model	Cal. Due Date	S/N
Microwave Spectrum Analyzer	HP 8566B (100Hz-22GHz)	08/15/98	3638A08713
Microwave Spectrum Analyzer	HP 8566B (100Hz-22GHz)	04/17/99	2542A11898
Spectrum Analyzer/Tracking Gen.	HP 8591A (100Hz-1.8GHz)	08/10/98	3144A02458
Signal Generator	HP 8640B (500Hz-1GHz)	08/09/98	2232A19558
Signal Generator	HP 8640B (500Hz-1GHz)	08/09/98	1851A09816
Signal Generator	Rohde & Schwarz (0.1-1000MHz)	09/11/98	894215/012
Ailtech/Eaton Receiver	NM 37/57A-SL (30-1000MHz)	04/12/99	0792-03271
Ailtech/Eaton Receiver	NM 37/57A (30-1000MHz)	03/11/99	0805-03334
Ailtech/Eaton Receiver	NM 17/27A (0.1-32MHz)	09/17/98	0608-03241
Quasi-Peak Adapter	HP 85650A	08/15/98	2043A00301
Ailtech/Eaton Adapter	CCA-7 CISPR/ANSI QP Adapter	03/11/99	0194-04082
RG58 Coax Test Cable	No. 167		n/a
Harmonic/Flicker Test System	HP 6841A (IEC 555-2/3)		3531A00115
Broadband Amplifier (2)	HP 8447D		1145A00470, 1937A03348
Broadband Amplifier	HP 8447F		2443A03784
Transient Limiter	HP 11947A (9kHz-200MHz)	2820A00300	
Horn Antenna	EMCO Model 3115 (1-18GHz)		9704-5182
Horn Antenna	EMCO Model 3115 (1-18GHz)		9205-3874
Horn Antenna	EMCO Model 3116 (18-40GHz)		9203-2178
Biconical Antenna (4)	Eaton 94455/Eaton 94455-1/Singer 94455-1/Compliance Design 1295, 1332, 0355		
Log-Spiral Antenna (3)	Ailtech/Eaton 93490-1		0608, 1103, 1104
Roberts Dipoles	Compliance Design (1 set)		
Ailtech Dipoles	DM-105A (1 set)		33448-111
EMCO LISN	3816/2		1079
EMCO LISN	3816/2		1077
EMCO LISN	3725/2		2009
Microwave Preamplifier 40dB Gain	HP 83017A (0.5-26.5GHz)		3123A00181
Microwave Cables	MicroCoax (1.0-26.5GHz)		
Ailtech/Eaton Receiver	NM37/57A-SL		0792-03271
Spectrum Analyzer	HP 8594A		3051A00187
Spectrum Analyzer (2)	HP 8591A		3034A01395, 3108A02053
Modulation Analyzer	HP 8901A		2432A03467
NTSC Pattern Generator	Leader 40B		0377433
Noise Figure Meter	HP 8970B		3106A02189
Noise Figure Meter	Ailtech 7510		TE31700
Noise Generator	Ailtech 7010		1473
Microwave Survey Meter	Holiday Model 1501 (2.450GHz)		80931
Digital Thermometer	Extech Instruments 421305		426966
Attenuator	HP 8495A (0-70dB) DC-4GHz		
Bi-Directional Coax Coupler	Narda 3020A (50-1000MHz)		
Shielded Screen Room	RF Lindgren Model 26-2/2-0		6710 (PCT270)
Shielded Semi-Anechoic Chamber	Ray Proof Model S81		R2437 (PCT278)
Environmental Chamber	Associated Systems Model 1025 (Temperature/Humidity)		PCT285

\* Calibration traceable to the National Institute of Standards and Technology (NIST).

## 7.1 SAMPLE CALCULATIONS

---

$$\text{Level } \mu\text{V/m @ 3 meters} = \frac{\text{Log } 10^{-1} (\text{dBm} + 107 + \text{AFCL})}{20}$$

$$\frac{\text{Log } 10^{-1} (-14 + 107 + 31.7)}{20}$$

$$1717908.4 \mu\text{V/m @ 3 meters}$$

Sample Calculation (relative to a dipole)

$$\text{EIRP (dBm)} = 10 \text{Log}_{10} \left( \frac{(r(\mu\text{V/m})1 \times 10^6)^2}{49.2/1 \times 10^{-3}} \right)$$

$$\text{EIRP (dBm)} = 10 \text{Log}_{10} \left( \frac{(3(1717908.4)1 \times 10^6)^2}{49.2/1 \times 10^{-3}} \right)$$

$$\text{EIRP (dBm)} = 27.32$$

## 8.1 RECOMMENDATION/CONCLUSION

---

The data collected shows that the **SONY Dual Mode Phone FCC ID: L5ACMZ200DM** complies with all the requirements of Parts 2 and 22 of the FCC rules.