



SONY[®]

3-867-100-11

CDMA PCS Telephone

Operating Instructions



D · W A V E
astra

©1999 Sony Electronics Inc.

CM-SB200



Before operating your portable dual band telephone, please read this manual thoroughly and retain it for future reference.

If your usage includes in-vehicle operation, refer to the Installation/Connections/Operation manual for the optional accessory kits.

DISPOSAL OF LITHIUM ION BATTERY

LITHIUM ION BATTERY.
DISPOSE OF PROPERLY.

You can return your unwanted lithium ion batteries to your nearest Sony Service Center or Factory Service Center.

Note: In some areas the disposal of lithium ion batteries in household or business trash may be prohibited.

For the Sony Service Center nearest you call 1-800-222-SONY (United States only).

For the Sony Factory Service Center nearest you call 416-499-SONY (Canada only).

WARNING

To prevent fire or shock hazard, do not expose the unit to rain or moisture.

FCC CAUTION STATEMENT

You are cautioned that any changes or modifications not expressly approved in this manual could void your authority to operate this equipment.

Owner's record

The model number, regulatory number, and serial number are located on a nameplate inside the battery compartment. Record the serial number in the space provided below. Refer to these numbers whenever you call your dealer regarding this product.

Model No.: _____ Serial No.: _____

©1999 Sony Electronics Inc. All rights reserved. Reproduction without written consent expressly prohibited. Sony, Jog Dial, D-WAVE logo and D-WAVE Astra are trademarks of Sony. Third party trademarks are the property of their respective holders. Design and specifications are subject to change without notice. Talk and standby times are subject to change.





Table of Contents

Getting Started

Unpacking your phone	4
Looking at your phone	5
Charging the battery	6
Turning the phone on	9
Activating your phone	11

Navigating

Navigating	12
Jog Dial™ navigator	12
Navigating keys	12
Menu map	13
List of menu items	14
Quick tips and features	16
First things first	18
Selecting a language	18
Getting your phone number ..	18
Alphanumeric table	19

Making & Receiving Calls

Calling fundamentals	20
Basic calling	20
Related calling functions	20
Limiting outbound calls	21
Calling from the Phone Book	22
Manually	22
Speed dialing	22
Touch dialing	22
Fast 4 dialing	23
Call prefixing	23
Calling from the Calls List	24
Additional Calls List info	24
Saving to your Phone Book ...	24
Incoming calls	25
Basic call answering	25
Related answering functions .	25
Setting all keys to answer	25
Setting automatic answer	26
Caller ID	26
Missed Calls	26
Using the scratch pad	26

Phone Book Functions

Storing information	27
Basic storage	27
If the Phone Book is full	27
Special storage functions	28
Searching your Phone Book	30
Alphabetically	30
By memory location	31
For a phone number	31
Editing Phone Book entries	32
Erasing Phone Book entries	33
Restricting Phone Book entries ..	34

Menu Settings

Sounds menu	35
Display menu	38
Security menu	40
Network menu	42
Extras menu	45
Timers menu	46

Carrier provided features and services

Short Messaging Service	48
Receiving messages	48
Message capacity	49
Message format	50
Accessing messages	50
Text messages	51
Voice mail	52
Sending and receiving data	53

Additional information

Troubleshooting	55
Specifications	56
Optional accessories	57
Rules and regulations	58
Safety precautions	59
Glossary	62
Index	64
Warranty Card	69
Quick Reference Card	71

Getting Started
Navigating
Making & Receiving Calls
Phone Book
Menu Settings
Carrier Features
Additional Info





Unpacking Your Phone

Carefully unpack your phone and check the contents using this list. If something is missing, please contact your nearest Sony dealer.

Portable Cellular/PCS Telephone (1)

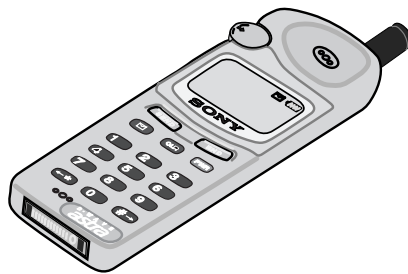

QN-400BPL2 Extended Life Lithium-Ion Battery (1)

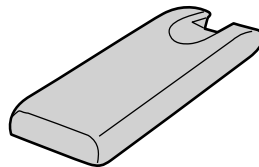

QN-301TA Travel Adapter (1)

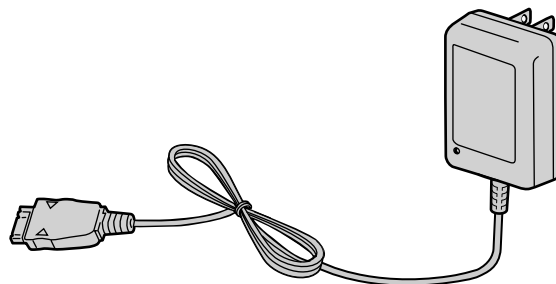

4



Looking at Your Phone

For more information, refer to the page numbers in parentheses ().

- 1 Antenna (18)**
- 2 Red/Green LED (XX)**
Alerts for incoming calls/messages and identifies charging status.
- 3 Earpiece**
- 4 Jog Dial™ navigator (14)**
Turn (scroll) and press (select) to access menus and settings.
- 5 Display (14)**
- 6 Ringer speaker**
- 7 SEND key (21 to 23)**
Press to make or receive calls.
- 8 M key (78)**
Press to access messages.
- 9 CLR key (19, 21, 40)**
Press to clear characters on the display or exit the current operation.
- 10 Number and * /# keys (21, 25, 49)**
Use the keypad to enter numbers and letters. Use * and # to move the cursor.
- 11 Microphone**
- 12 PWR key (18)**
Press to turn the phone on or off.
- 13 END key (19, 21, 23)**
Press to end calls or cancel operations and return to standby mode.
- 14 Battery release tab (15)**
Slide up to remove the battery.
- 15 Battery (15)**
- 16 Connector (16)**
Connects the phone to the travel adapter or other accessory.

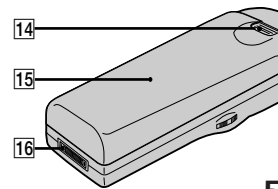
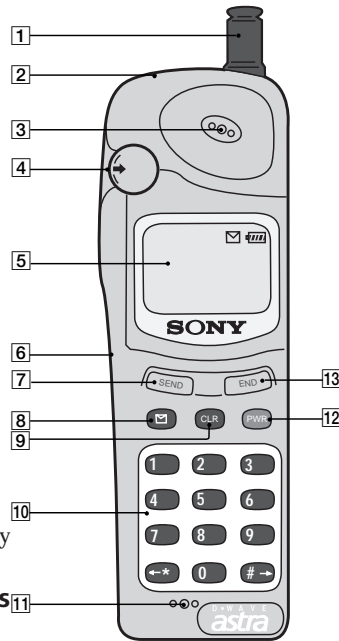

Getting Started



Charging the Battery

A new battery is not fully charged so it's best to charge the battery before using the phone. The following instructions show you how to attach/detach the battery and connect the supplied travel adapter.

To attach the battery

- 1 Hook the battery onto the bottom of the phone ①, then lower the top down ②.

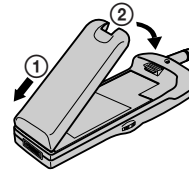

- 2 Press down firmly on the thumb indent to secure the battery in place.

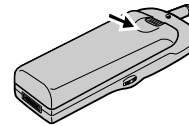

To remove the battery

- 1 Place your thumb on the battery release tab and press upward.

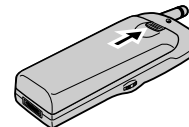

- 2 Lift the top of the battery ①, then remove it from the back of the phone ②.

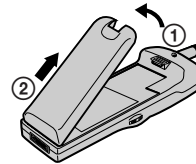



Charging the battery

Connect the travel adapter to the phone connector ①, then plug it into a standard 120V AC outlet ②. Charging time is about 5 hours. Charging will take longer if the phone is turned on.

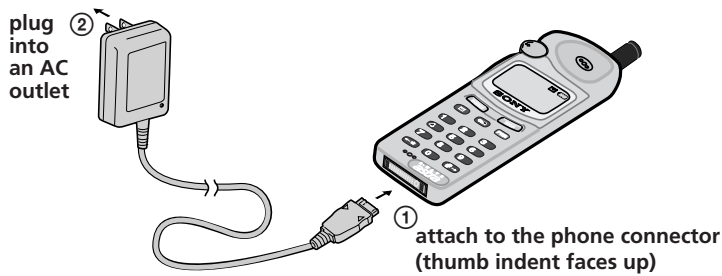

What you'll see when the battery is being charged

	When phone is ON	When phone is OFF
During charging	<ul style="list-style-type: none"> • flashes • CH is displayed in the upper left corner of the standby display • LED is not lit 	<ul style="list-style-type: none"> • flashes • Battery is Charging is displayed on the display screen • LED flashes red
Battery fully charged	<ul style="list-style-type: none"> • stops flashing • FCH is displayed in the upper left corner of the standby display • LED is not lit 	<ul style="list-style-type: none"> • stops flashing • Charging is Complete is displayed on the display screen • LED turns green

Cautions

- Use only Sony-approved batteries and use only as intended. Don't try to disassemble or dispose of them in a fire (possible personal injury).
- Avoid charging for long periods of time, in places with high humidity, direct sunlight or extreme temperatures (below 32°F / 0°C or over 104°F / 40°C).
- The battery may become warm during charging or after use.
- Replace the supplied AC adapter if necessary. It is not intended to be serviced.
- The AC Adapter allows you to turn on your phone without a battery attached. But without a battery attached, you won't be able to make or receive calls.





Battery life

Standard battery

	CDMA mode	Analog mode
Standby mode	72.0 hours	14.0 hours
Talk time	3.0 hours	1.5 hours

Extended battery

	CDMA mode	Analog mode
Standby mode	144.0 hours	28.0 hours
Talk time	6.0 hours	3.0 hours

Battery condition

The battery icon indicates the *approximate* charge level remaining in the battery. Energy consumption varies depending on conditions of use (including ambient temperature, network coverage and usage patterns). The fewer lines you see inside the battery icon body, the less charge it has.

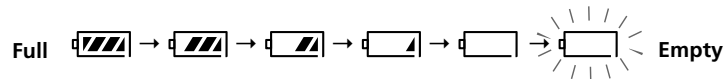

When the battery is empty

When your battery charge is very low, the icon flashes and a warning message is displayed to remind you. The phone automatically turns off when the battery runs out of energy. If this happens during a call, you will hear a beep and the call will be cut off. Recharge the battery as soon as possible.





Turning the Phone On

Extending and retracting the antenna

Extend the antenna to maximize signal strength and minimize interference. When you make or receive a call, hold the end of the antenna and pull up until fully extended. When you are not in a call, push the antenna down until fully retracted.

LED

PWR



Getting Started

Powering on

To turn your phone on, hold down **PWR** for about two seconds. **Powering On** appears on the screen, the LED flashes green, the phone beeps and searches for a signal. When a service signal is found, the standby display appears. Your phone is ready to use.

Powering off

Hold down **PWR** for about two seconds. The phone beeps and displays the message **To turn off: Hold down the POWER Key**. You hear a second beep, then **Powering off** appears on the screen. When you release **PWR**, the phone turns off.

Display screen

Your phone's display screen has five information lines. Each line can display up to 12 characters. The top line displays icons which tell you the status of your phone. Lines two through five change depending on the current operation. The bottom line is usually a prompt for an operation. See the following basic examples:

Standby mode	
phone status	[Icons]
"banner"	My Phone
time and date	12:34P 12/25
menu prompt	[C]: Saved #s
menu prompt	[>]: Features

Phone Book	
phone status	[Icons]
name	Sony
phone #	555-1212
menu prompt	[>]: Options

The next page provides detailed information regarding your phone's display.

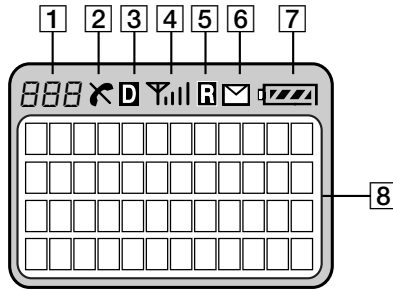

- 1 Short character display**
Identifies the display based on the current operation.

 - Features menus/submenus begin with “F”.
 - Calls List memory locations begin with “C”.
 - Phone Book memory locations are all digits.

- 2 (in-use) / (out-of-service) icon (18, 21, 23, 71)**
Indicates within or outside a service area. A phone icon (☎) appears during a call. A slash through it (☎) appears when no signal is received, which means you cannot make or receive calls. The phone will search for a service signal. If it can't find one, it enters power save mode and “wakes up” automatically (at intervals based on carrier network settings) to search for a service signal.

- 3 (digital) icon**
Appears when your phone is operating in digital (CDMA) mode.

- 4 (signal strength) icon (18)**
Shows the approximate strength of the signal being received. The more lines displayed, the stronger the signal. The icon changes if the signal strength fluctuates. It's best when the signal is strong, but calls can be made when it's weak.

- 5 (roam) icon (71)**
Appears when you are roaming outside your home service area.

- 6 (message) icon (77)**
Appears when you have new text or voice mail messages. The icon flashes if the new message is urgent.

- 7 (battery) icon (16, 17)**
Shows the approximate amount of energy remaining in the battery. Recharge the battery before it is fully discharged.

- 8 Character display**
Displays phone numbers and names, prompts various actions and displays results.





Activating Your Phone

First time activation

In order to make and receive calls, you need to establish telephone service from a service provider. Many companies provide service. Choose a service provider that will meet your calling needs.

Self-activating your phone

Some service providers have a service feature called *OTASP* (Over-The-Air Service Provisioning) which allows you to self-activate your phone with a new service. Your phone supports this service feature. Contact your service provider to see if this service is available in your area.

1 From the Network menu, scroll and select Activation.

2 Scroll and select which system block to activate the service on.

A display appears prompting you for confirmation. To go back one step, press **CLR**. To cancel activation and return to the standby display, press **END**.

3 Press **1 to confirm.**

The phone calls up a service provider. When a service provider is contacted, a message appears and you are connected to an operator. When activation is complete, a confirmation message appears followed by the standby display.

If activation fails

A message appears advising you that activation failed. Push *Jog Dial* to retry or press **END** to return to the standby display.



Navigating

Jog Dial navigator: scroll and select

Your Sony portable phone is easy to use thanks to the *Jog Dial navigator*. The instructions in this manual will tell you to “scroll and select”. To scroll, turn *Jog Dial* up or down. When the flashing arrow points to the item you want to select, push *Jog Dial* in toward the phone.

Navigating keys

Key	Action	Destination
CLR	Press	previous menu
CLR	Hold down	standby display
END	Press	standby display

Note

The phone automatically returns to standby after 30 seconds of inactivity (e.g., you haven't scrolled, selected or pressed any key).

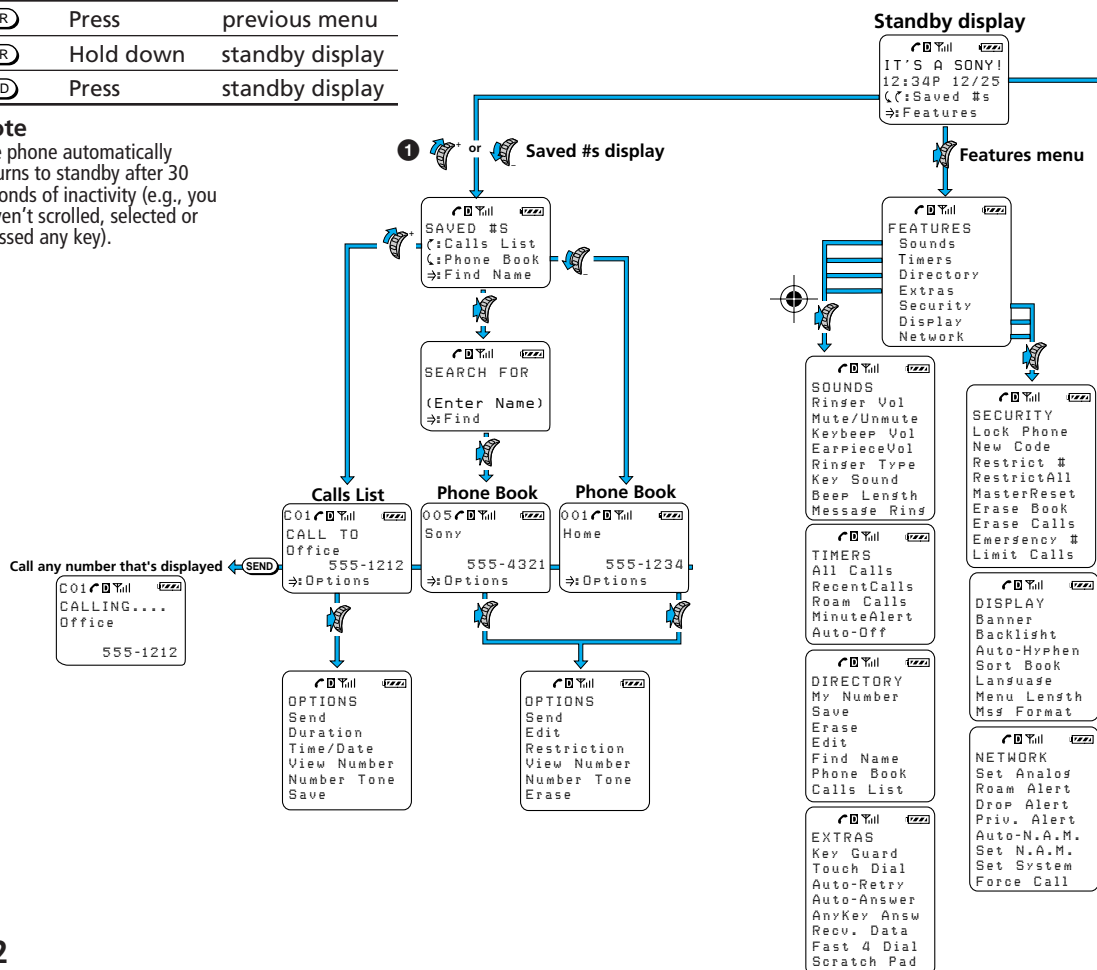



Menu Map: How do I get there?

There are three navigation routes from the standby display:

- 1 Turn *Jog Dial* in either direction to access numbers saved in memory.
- 2 Press *Jog Dial* to access the Features menu.
- 3 Enter a digit.

To see the complete list of menus, submenus and corresponding settings, see the "Menu list" on pages 12 and 13.

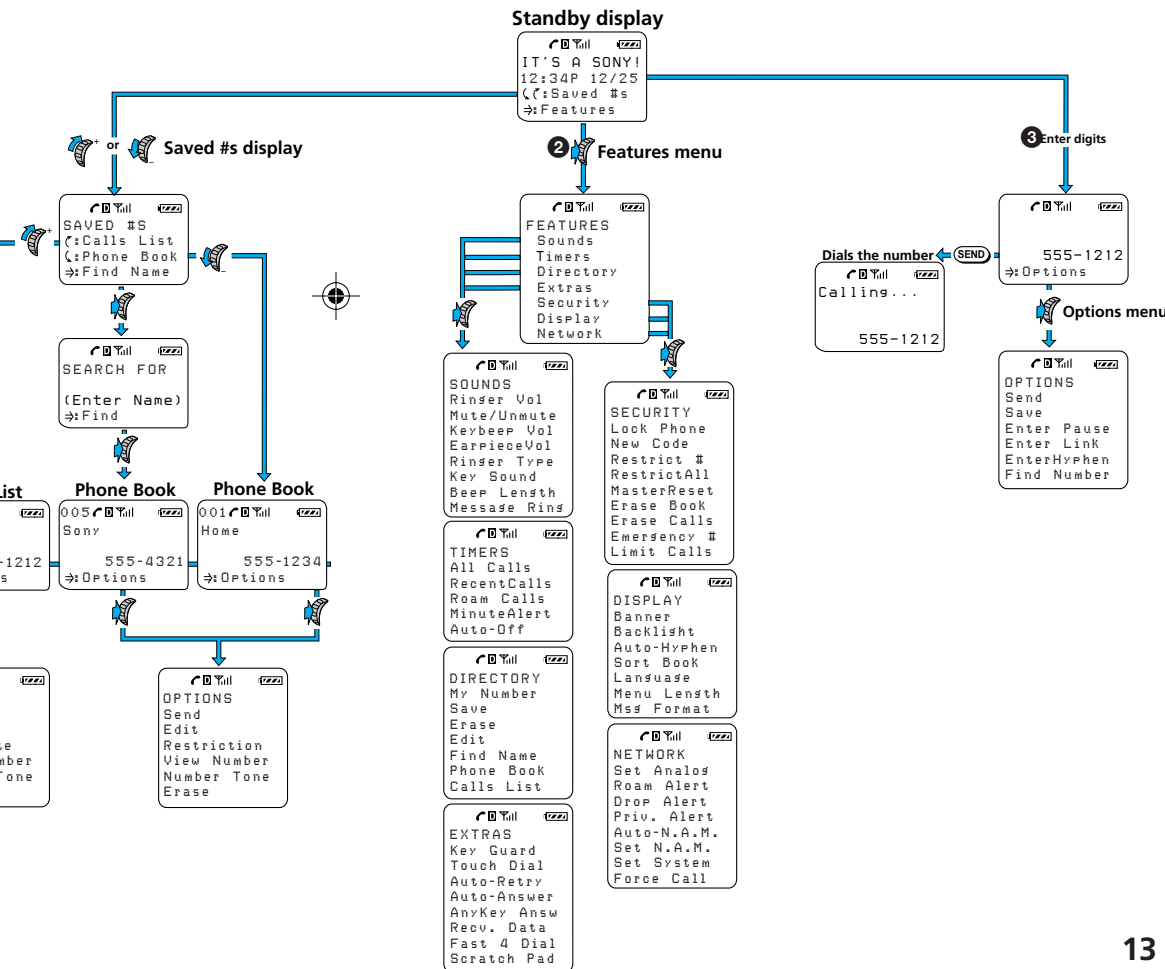



List of Menu Items

The Features menu allows you to personalize the way your phone functions. This menu list shows the entire Features menu (a.k.a. long menu). The Features menu includes seven categories of menus. Within each of these menus are submenus identified by a “menu item number” (they begin with the letter “F” (Features) followed by two digits). Menu item numbers allow you to quickly access any menu from the Features menu (for example, to access the earpiece volume menu press **1** **4**). Current submenu settings are indicated by a check mark (✓) and displayed in capital letters.

	Submenu	Settings	Page
Features menu 1 F-1 Sounds	F11 Ringer Vol.	off/low/med./high/escalate/vibrate	41
	F12 Mute/UnMute	mutes or unmutes the microphone	42
	F13 Keybeep Vol	off / low / med. / high	42
	F14 Earpiece Vol	1 / 2 / 3 / 4 / 5 / 6 / 7	43
	F15 Ringer Type	option 1 to 5 / melody 1 to 5	43
	F16 Key Sound	tones / clicks	44
	F17 Beep Length	standard / long	44
	F17 Msg Ringer	on / off / +reminder	44
Features menu 2 F-2 Timers	F21 All Calls	total call time, number of calls	45
	F22 Recent Calls	total call time, number of calls	45
	F23 Roam Calls	total call time, number of calls	46
	F24 Minute Alert	before min/each min/every 5 min/off	44
	F25 Auto-Off	in 3 hrs / in 2 hrs / in 1 hr / in 30 mins / never	47
Features menu 3 F-3 Directory	F31 My Number	—	48
	F32 Save	—	48
	F33 Erase	—	50
	F34 Edit	—	51
	F35 Find Name	—	52
	F36 Phone Book	No default entries	54
	F37 Calls List	No default entries	55



	Sub Menu	Settings	Page
Features menu 4 F-4 Extras	F41 Keyguard	—	56
	F42 Touch Dial	on / off	57
	F43 Auto-Retry	off / on 10 sec / on 30 sec / on 60 sec	57
	F44 Auto-Answer	on / off	58
	F45 AnyKey Answ	on / off	58
	F45 Recv. Data	off / fax / modem / PC Control	58
	F46 Fast 4 Dial	on / off	58
	F47 Scratch Pad	—	59
Features menu 5 F-5 Security	F51 Lock Phone	never / on power-up / right now	60
	F52 New Code	0000	61
	F53 Restrict #	No default on restricted numbers	62
	F54 Restrict All	on / off	63
	F55 Master Reset	—	64
	F56 Erase Book	—	64
	F57 Erase Calls	—	65
	F58 Emergency #	No default emergency numbers	65
	F59 Limit Calls	Off/ incoming/ to loc 1-9/ to loc 1-99	65
Features menu 6 F-6 Display	F61 Banner	No default banner	66
	F62 Backlight	always off / for 7 secs / for 15 secs / for 30 sec / always on	67
	F63 Auto-hyphen	on / off	68
	F64 Sort Book	by loc. # / alphabetic	68
	F65 Language	English/ French/ Spanish/ Port	20, 69
	F66 Menu Length	long / short	69
	F67 Msg. Format	none/ partial/ full	77
Features menu 7 F-7 Network	F71 Set Analog	disabled / until off / automatic	70
	F72 Roam Alert	on / off	71
	F73 Drop Alert	on / off	72
	F74 Priv. Alert	on / off	73
	F75 Auto-N.A.M.	on / off	74
	F76 Set-N.A.M.	N.A.M. 1 / N.A.M. 2	74
	F77 Activation	on Blocks A thru F	75
	F78 System Pref.	standard / home only	76

Navigating



Quick Tips and Features

Here is a list of your phone's features which simplify your calling experience.

MAKING CALLS

Calling displayed phone numbers	<ul style="list-style-type: none"> • Push SEND to call a phone number anytime it's displayed on the screen.
Speed dialing	<ul style="list-style-type: none"> • Your phone is able to speed dial phone numbers stored in your Phone Book: Enter the memory location number and press [send].
Touch dialing	<ul style="list-style-type: none"> • Your phone is able to dial at the touch of the memory location number: Enter the memory location number, but keep pressure on the last digit until connecting appears on the display.
Automatic redial	<ul style="list-style-type: none"> • Need to get through to a difficult number? Set your phone to automatically redial until successful!
Searching for a phone number to call	<ul style="list-style-type: none"> • There are several ways to search for a phone number: <ul style="list-style-type: none"> - Scroll through your entire Phone Book or Calls List - Quick alphabetic search - Alphabetic search - Number search
Muting the microphone	<ul style="list-style-type: none"> • Push and hold Jog Dial to quickly mute and unmute the microphone during a call.
Call prefixing	<ul style="list-style-type: none"> • Quickly add a prefix to local numbers stored in your Phone Book. This is helpful when you're traveling outside your area code.
Viewing long phone numbers	<ul style="list-style-type: none"> • If a number is too long to fit on the screen, view the overflow digits by selecting View Number on the Options menu.
Emergency numbers	<ul style="list-style-type: none"> • You can call 911 and your three stored emergency numbers even if your phone is locked or calls are limited.





RECEIVING CALLS

AnyKey Answer

- You can set your phone to answer incoming calls with any key except **(PWR)**.

Setting your phone to answer calls automatically

- A Hands-Free Car Kit is a handy accessories that allows you to set your phone to answer calls automatically on the second ring.

Muting the ringer

- Quickly mute the ringer by turning Jog Dial down or pressing the [end] key.
-





PHONE FEATURES and FUNCTIONS

Navigating

- Quick menu access
Each menu item can be accessed quickly from the standby display by pushing Jog Dial, entering the menu item number, then pressing Jog Dial again.
- Previous menu
Press [clr] to quickly go back to the previous menu.
- Return to standby
Press [end] or hold down [clr] to quickly return to standby.
The display automatically returns to standby after 30 seconds of inactivity.

Stored information

- Phone Book (permanent storage of information)
Your phone can store up to 199 entries. You can make calls from your Phone Book. You can view your Phone Book from the standby display or the Directory menu.
- Calls List (temporary information)
Your phone stores a list of your 10 most recent calls. You can make calls from your Calls List. You can save information from your Calls List to your Phone Book. You can view the Calls List from the standby display or from the Directory menu.
- DTMF signals
You can store DTMF signals in your Phone Book and send them automatically.

Backlight

- Your phone has two backlight settings: one in charging mode and one in battery mode. For faster charging while in charging mode, you may want to change the setting from always on (which is set at the factory).
- You can activate the backlight while KeyGuard is on:
Push and hold Jog Dial.





Volume

- Turn Jog Dial up or down to quickly adjust the earpiece volume during a call.
- Turn Jog Dial up or down to quickly adjust the ringer volume while the phone is ringing.
- Turn Jog Dial down or press [end] when the phone is ringing to mute the ringer.
- Press and hold Jog Dial to mute the microphone during a call.

Locking the keypad

- Push and hold Jog Dial to quickly lock the keypad.

Keyguard vs lock phone vs limit calls

- You can lock the keypad even when the phone itself is locked.
 - The keypad unlocks when you answer a call then relocks when the call is finished.
 - Keyguard prevents the keys from accidentally being pushed. This is particularly helpful when you transport your phone.
 - Lock phone prevents anyone from using your phone unless a security code is entered. This is important not only to ensure phone calls are made with your permission, but also to ensure the privacy of information contained in your phone's memory.
 - Limit calls doesn't lock the keys or the phone, but allows you to limit the calls that can be made from your phone.
-





First Things First

Selecting a language

When you receive your phone, the menus are displayed in English, but you can change the menu language. To change the menu language, follow the instructions below.

- 1 From the **Features** menu, scroll and select **Display**.
- 2 Scroll and select **Language**.
- 3 Scroll and select **English, French, Spanish or Portuguese**.

Getting your phone number

Your phone number has its own submenu; just in case you forget it.

- 1 From the **Directory** menu, scroll and select **My Number**.
- 2 Push *Jog Dial* to exit.



Entering information



Entering numbers: To enter numbers, just press the numbers on the keypad.

Entering characters: You can enter characters as well as numbers using the keypad. When prompted to enter characters, press the key that has the character you want to enter printed on it. Continue pressing it until the character is displayed (lower case letters follow capitals). Refer to the alphanumeric table on the next page to see a complete list of numeric keys and corresponding characters. Each menu language has its own alphanumeric table. Once entered, special language characters (e.g., letters with accents) display regardless of the current menu language!

Moving the cursor: To enter the next character, press the corresponding key. If it's the same as the last, wait three seconds and the cursor will move automatically. Or, manually move the cursor to the next space with *Jog Dial* or arrow keys (***→**/**#→**).

For example, to enter "SONY":

- Press **7^{PG}_{RS}** four times to enter an "S".
- Press **6^{MND}** three times to enter an "O".
- Press **6^{MND}** twice to enter an "N".
- Press **9^{WX}_{VZ}** three times to enter a "Y".





Alphanumeric table

Key	English Sequence
1	- " . ' , & () : 1
2 ABC	A B C a b c 2
3 DEF	D E F d e f 3
4 GHI	G H I g h i 4
5 JKL	J K L j k l 5
6 MNO	M N O m n o 6
7 PQRS	P Q R S p q r s 7
8 TUV	T U V t u v 8
9 WXYZ	W X Y Z w x y z 9
0 OP*	0

Navigating

Alphanumeric tables for other languages

To view another language table, refer to the respective phone operating instructions. Not all areas distribute the phone operating instructions in all languages. To obtain operating instructions in another language, contact Sony Customer Service.

Correcting and exiting

When you want to:	Do this:
Change a character entered	Press CLR to correct mistakes.
Cancel operation and return to standby	Hold down CLR or press END .





Calling Fundamentals

You can call any number up to 32 digits when you are within a service area. If you are outside a service area, ✕ appears on the display.

There are several ways to make calls, including dialing manually, speed dialing, touch dialing or recalling a stored number.

Basic calling

The most basic way to call any phone number is to dial it manually.

- 1 Enter a phone number on the standby display and press **SEND**.

The phone dials the number and the icon appears. When the call is connected, the call timer appears.

To correct mistakes	Press CLR .
To return to standby	Hold down CLR or press END .

- 2 Press **END** to disconnect the call.

The icon disappears and the final elapsed call time flashes.

Related calling functions

Volume adjustments during a call

Earpiece: Adjust the earpiece volume during a call by simply turning *Jog Dial* up to increase and down to decrease.

Speaker: To quickly mute the microphone during a call, push and hold *Jog Dial*. Push and hold again to unmute.

Redialing

Last number called

From standby, press **SEND** to automatically redial the last number dialed.

Automatic redial of unsuccessful call attempts

If a phone call doesn't go through (e.g., busy or no answer), you can set your phone to redial automatically up to five times.

- 1 From the Extras menu, scroll and select Auto-Retry.
- 2 Scroll and select off, on 60 secs, on 30 secs or on 10 secs.





Limiting outbound calls (*limit calls*)

Limit calls is a function that allows you to control calls that can be made from your phone. You can limit outgoing calls to specific segments of your Phone Book, while leaving incoming calls unaffected. Both **limit calls** and **lock phone** allow you to call 911 and your three stored emergency numbers. This function simply limits your outgoing calls whereas, locking your phone restricts your entire phone.

Setting	Limitation
Off	No limitation; calls can be made to any number.
To incoming	Only calls to 911 and stored emergency numbers can be made.
to loc 1-9	You can only call Phone Book entries 1-9, 911 and stored emergency numbers.
to loc 1-99	You can only call Phone Book entries 1-99, 911 and stored emergency numbers.



- 1 From the Security menu, scroll and select Limit Calls.
- 2 Scroll and select off, to loc 1-9, to loc 1-99 or to incoming.



Making calls when outgoing calls are limited

If you've chosen to limit outgoing calls, it doesn't matter how you attempt the call (e.g., dialing manually, from the Phone Book or Calls List) the phone number is checked against the Phone Book (pauses and links are ignored). If the number is not in the Phone Book or in a limited location, an error message is displayed. The phone number is still displayed when the standby display reappears, so you can edit it.

Changing the Phone Book when outgoing calls are limited

If you've chosen to limit outgoing calls, you cannot change your Phone Book (including saving, editing or restricting).

Restricted Phone Book entries

You will still be prompted to enter the lock code for restricted Phone Book entries whether or not your outgoing calls are limited.





Calling From the Phone Book

Your phone has an internal Phone Book. Once you create entries in your Phone Book (see the Phone Book section), dial stored numbers quickly by selecting an entry, **speed dialing**, **touch dialing** or **fast 4 dialing**.

Note

If the Phone Book entry includes a pause or link, push **Jog Dial** to release the remaining numbers.

Selecting a Phone Book entry manually

- | | |
|---|--|
| <ol style="list-style-type: none">1 From standby, scroll and select Saved #s.2 Scroll and select Phone Book.3 Scroll to select the Phone Book entry you want to call.4 Push Jog Dial twice to automatically dial. | <ol style="list-style-type: none">1 From the Features menu, scroll and select Directory.2 Scroll and select Phone Book. |
|---|--|



Speed dialing

There's no need to program speed dial numbers. You just have to know the memory location number. You can speed dial memory locations 01 to 99.

- 1 From standby, enter the memory location number, then press **SEND**.

The Phone Book entry in that memory location appears and the phone dials the stored number.



Touch dialing

- 1 From the Extras menu, scroll and select Touch Dial.
- 2 Scroll and select on or off.

Once **Touch Dial** is on, dial using just the memory location number.

- 1 From standby, enter the memory location number and hold down the last digit for about two seconds.

The Phone Book entry in that memory location appears and the phone dials the stored number.





Fast four-digit dialing (*fast 4 dial*)

Fast 4 dial allows you to dial just the last four digits of a phone number stored in your Phone Book. The last four digits of the number you want to dial must be unique (e.g., only one phone number in your Phone Book has those last four digits).

- 1 From the Extras menu, scroll and select **Fast 4 Dial**.
- 2 Scroll and select **on** or **off**.

Once you've turned *fast 4 dial* on, you can dial using this feature:

- 1 From standby, enter the last four digits of the phone number you want to call, then press **SEND**.
The phone searches your entire Phone Book for those exact digits.

Automatic dial

If only one Phone Book entry matches, the phone automatically dials it for you.

Error message

An error message is displayed if more than one Phone Book entry has those four digits or no Phone Book entries match the digits.

Pauses and links

For entries with pauses or links, the four digits preceding the first pause or link in the entry are used to match the entered digits.

Call prefixing

It's not unusual to leave out the area code when you store "local" numbers in your Phone Book. However, this may pose a problem when you travel. When you're outside your normal area code and you want to call one of these local numbers, temporarily add the area code (prefix) and dial it like this:

- 1 Scroll and select the Phone Book entry you want to call, then push **Jog Dial** to display the Options menu.
- 2 Scroll and select **Prefix**.
When prompted, enter the prefix (area code).
- 3 Push **Jog Dial** to automatically dial the number.





Calling From the Calls List

The Calls List is a chronological history the phone keeps of your ten most recent calls (outgoing, incoming, missed, fax calls or data calls) and scratch pad entries. If you call the same number twice in a row, only the most recent call is stored. Each Calls List entry includes:

- The type of entry (Call To, Call From, Missed and Added)
- Corresponding name (if the digits match a Phone Book entry)
- Digits (phone number or Scratch pad entry)

From standby mode

- 1 Turn *Jog Dial* once to access the **Saved #s** menu.
- 2 Turn *Jog Dial* up to select **Calls List**.
- 3 Use *Jog Dial* to scroll through your **Calls List**.
When the entry you want to call is displayed, press **SEND** or push *Jog Dial* twice to call it.

From the Directory

- 1 Scroll and select **Calls List**.
- 2 Use *Jog Dial* to scroll through your **Calls List**.
When the entry you want to call is displayed, press **SEND** or push *Jog Dial* twice to call it.

Additional Calls List information

Your phone stores additional information that isn't displayed on the Calls List screen, including:

- Time and date of the entry
- Duration of the entry.
- Digits that don't fit on one display line (only the last 12 digits appear on the Calls List display).

To view additional information

- 1 Scroll to view a **Calls List** entry, then push *Jog Dial* to display the **Options** menu.
- 2 Scroll and select **View Number, Duration, or Time/Date**.

Saving a Calls List entry to your Phone Book

Your Calls List is only temporary storage for your ten most recent call items. When a new item is added, the oldest item is deleted. If you want to keep a Calls List entry, save it to your Phone Book.

- 1 Scroll to view a **Calls List** entry, then push *Jog Dial* to display the **Options** menu.
- 2 Scroll and select **Save** then follow the screen prompts.

26



Incoming Calls

You can receive calls as long as the icon is not displayed. When you receive a call, the ringer sounds and the LED flashes green with each ring. Incoming Call flashes on your phone's display.

Basic call answering

- 1 Press **SEND** to answer the call.
When the call is connected, the call timer appears.
- 2 Press **END** to disconnect the call.
The icon disappears and the final elapsed call time flashes for 10 seconds.

Related answering functions

Adjusting volume

The Sounds menu allows you set the various volume settings. To change the volume of the ringer, earpiece and microphone for individual calls:

Ringer while it's ringing	Increase volume	Turn <i>Jog Dial</i> up.
	Decrease volume	Turn <i>Jog Dial</i> up then down.
	Mute the ringer	Turn <i>Jog Dial</i> down or Press END .
Earpiece during a call	Increase volume	Turn <i>Jog Dial</i> up.
	Decrease volume	Turn <i>Jog Dial</i> down.
Microphone during a call	Toggle between mute and unmute	Push and hold <i>Jog Dial</i>

Setting all keys to answer

As an added convenience, you can set your phone to answer incoming calls with any key (except **PWR**).

- 1 From the Extras menu, scroll and select AnyKey Answ.
- 2 Scroll and select on or off.

Note: If AnyKey Answ is on, pressing **END**, will mute the ringer, but will not answer the call.



Setting the phone to answer automatically

When the phone is used with a Sony Hands-Free Car Kit, it can automatically answer calls on the second ring.

- 1 From the Extras menu, scroll and select Auto-Answer.**
- 2 Scroll and select on or off.**
If you select on and the phone is in the hands-free car kit, the message -AutoAnswer- is displayed on the standby display.

Caller ID

Incoming calls

If caller ID is supported, the caller's phone number appears on the display when you receive an incoming call or call waiting alert. If the Caller ID number matches a Phone Book entry, the corresponding name is also displayed.

Missed calls

If you miss an incoming call, you will hear an alert (beep) and a message appears on the display. To return to standby, press **CLR**, **END** or **Jog Dial**. The caller's number will be stored in your Calls List if Caller ID is supported.

Using the scratch pad

Your phone has a scratch pad feature which is useful for temporarily holding information such as a phone number. It's easy to find at the bottom of the Extras menu. The phone doesn't send DTMF tones from the scratch pad, but you will hear tones when you enter digits if your keybeeps aren't turned off.

- 1 Scroll and select Scratch Pad.**
- 2 Use the keypad to enter the digits, then push Jog Dial.**
The Options menu appears. You can also enter hyphens, pauses and links (see page 27).
- 3 Scroll and select Store&Exit.**
The information is stored as a scratch pad entry in the Calls List.





Storing Information

Your phone has an internal Phone Book for up to 199 entries (each with its own memory location number). Phone Book entries can be numbers up to 32 digits (phone, credit card, medical record, etc.) and corresponding names up to 12 characters. Things to keep in mind when creating your Phone Book:

- It's a good idea to use the first nine memory locations for numbers you call most often.
- Consider whether you want to use last names first since it will affect searching your Phone Book.

Basic storage

Entries can be stored in your Phone Book from Standby mode or the Directory menu.

From standby mode

- 1 Enter the number you want to save, then push ***Jog Dial***.
- 2 Scroll and select **Save**.

- 3 Enter a name to identify the number you entered, then push ***Jog Dial*** to save.

For information on entering characters, see the "Alphanumeric table" on page 20.

- 4 Push ***Jog Dial*** again to store it in the first available memory location.

To store it in another memory location, scroll to that memory location or use the keypad to enter the memory location number, then push ***Jog Dial***. A confirmation message appears followed by the status of the Phone Book.

From the Directory menu

- 1 Scroll and select **Save**.
- 2 Enter the phone number you want to save, then push ***Jog Dial***.

If the Phone Book is full

A message appears when you try to save if no more memory locations are available. You can cancel or overwrite another memory location.

- To cancel, hold down **(CLR)**.
- To overwrite an existing memory location, enter it using the keypad or scroll through your Phone Book to display it, then press ***Jog Dial***. A confirmation message appears. Press ***Jog Dial*** again to confirm.



Special storage functions

Hyphens, pauses and links are special functions that can be stored in your Phone Book entries.

Hyphens in Phone Book entries

Your phone has a default setting of autohyphenation ON. When you enter digits, the phone assumes you are entering a standard U.S. phone number (such as 800-555-1234). Every fourth and eighth character is a hyphen. To enter hyphens manually (to store a foreign phone number or other type of number), turn autohyphenation OFF (see page 68).

Using pauses and links to Send DTMF signals

Dual Tone Multiple Frequency (DTMF) is also known as “touch-tone”. Each key on your phone’s keypad generates a distinct tone (number tone). You use DTMF signals when you call electronic services such as answering machines, pagers, telephone banking services, etc. (e.g., a number that asks if you are calling from a touch-tone phone then prompts you to enter information using the keypad). DTMF signals can be used to route the call or identify the person calling. Instead of sending the number tones manually one-by-one using the keypad, you can store them in your Phone Book and send them at the touch of a key.

Notes

- You can send DTMF signals only during a call.
- To change the length of the DTMF transmission, see “Setting the keybeep length” on page 44.

When you dial a Phone Book entry that has a hard pause or link in it, the phone displays and dials only the numbers up to the hard pause or link. When prompted, press **Jog Dial** to release the hard pause or link and transmit the next set of digits. A time pause waits for a specified period of time before sending the second string automatically.

Pauses in Phone Book entries

The pause function allows you to save a phone number and corresponding DTMF signals together in the same Phone Book entry.

- 555-1212 **[H]**123 is an example of calling 555-1212, then extension 123 using a hard pause.
- 555-1212 **[T]**123 is an example of calling 555-1212, then extension 123 using a time pause.





Linking Phone Book entries

Use the link function if the combined phone number and corresponding DTMF signals exceed 32 digits. 555-1234 **L**50 is an example of calling 555-1234, then linking the number in memory location 50 (i.e., your medical record number).

Adding hyphens, pauses or links in a Phone Book entry

- 1 Enter all digits to be dialed prior to the hyphen, pause or link, then push *Jog Dial*.
- 2 Scroll and select enter hyphen, hard pause, time pause or enter link.

A special character is displayed (“-”, “**H**”, “**T**” or “**L**”) then the phone is ready to accept additional digits.

- 3 Enter the next set of digits, then push *Jog Dial*.
 - If you chose enter hyphen continue entering digits as needed.
 - If you chose time pause or hard pause, enter the digits (number tones) to be released.
 - If you chose enter link, enter the memory location you used to store the digits (number tones).
- 4 When the entry is complete, scroll and select **Save** and follow the remaining save prompts.

Sending DTMF signals manually from the Phone Book

You don't have to include the DTMF signal(s) with the phone number (pause or link function). You can store the DTMF signals in a Phone Book memory location (as in the link function), then when needed, send the number tones manually from your Phone Book as follows:

- 1 Dial the phone number.
- 2 Use the Directory menu to locate the Phone Book entry that contains the numbers you want to send, then push *Jog Dial*.
- 3 Scroll and select **Number Tone**.
A DTMF signal containing the entered digits is sent in a burst.



Searching the Phone Book

Information stored in your Phone Book is sorted either alphabetically (the first character of the memory location) or numerically by memory location number. So, one way to search your Phone Book is to simply scroll using the *Jog Dial*. No matter how your Phone Book is sorted, you can find information quickly by searching alphabetically, by memory location or phone number. Once a Phone Book entry is displayed, you can call it by pressing  or *Jog Dial* twice.

Searching your Phone Book alphabetically

Quick alphabetic Phone Book recall

If your Phone Book is sorted alphabetically, you can search using the phone's keypad. For example, when viewing your Phone Book, press [2] and entries that begin with "A" are displayed. Press [7] four times to display entries that begin with "S". If no entries that begin with that letter, it looks for the next letter on the key. If there aren't any entries for any of the letters on the key, it searches for the first letter of the next key. Once the phone displays an entry, you can use *Jog Dial* to scroll up or down from there.



Alphabetic search

You can search alphabetically using as little as 1 character or as many as 12 characters. Search from standby mode or from the Directory menu.

From standby mode

- 1 Turn *Jog Dial* once to select **Saved #s**.
- 2 Push *Jog Dial* to select **Find Name**.
A message prompts you for a search string.

From the Directory menu

- 1 Scroll and select **Directory from the Features menu**.
- 2 Scroll and select **Find Name**.
A message prompts you for a search string.

- 3 Enter the first character of the name you want to find (two or more consecutive characters is best), then push *Jog Dial*.
 - If you entered only one character, all Phone Book entries that begin with that character are displayed alphabetically.
 - If you entered two or more characters, all Phone Book entries that contain those consecutive characters are displayed starting from the lowest memory location number.

- 4 Scroll to view the list of matched character(s).

32





Searching by memory location number

You can search for a memory location number in your Phone Book from standby mode or the Directory menu.

From standby mode

- 1 Enter a memory location, then push *Jog Dial*.**
- 2 Scroll and select *Recall Loc#*.**
A message appears if the memory location is empty.

From the Directory menu

- 1 Scroll and select *Phone Book*.**
A message prompts you for a memory location.
- 2 Enter a memory location, then push *Jog Dial*.**
A message appears if the memory location is empty.

Searching for a phone number

You can only search for a phone number from standby mode.

- 1 Enter at least the first three digits of the phone number you want to find, then push *Jog Dial*.**
- 2 Scroll and select *Find Number*.**
All entries matching the entered digits are displayed. The list is displayed either alphabetically or by memory location depending on the Sort Book setting. A message is displayed if a matching Phone Book entry is not found.
- 3 Scroll to view the next entry that contains the search string.**



Editing Phone Book Entries

You can edit the name, phone number and memory location of entries stored in your Phone Book. If the selected Phone Book entry is restricted, you must enter a four-digit lock code to edit it. You can edit Phone Book entries from standby mode or the Directory menu.

From standby mode

- 1 Scroll down twice to access your Phone Book.**
- 2 Scroll to the Phone Book entry you want to edit, then push *Jog Dial*.**
- 3 Scroll and select *Edit*.**
A message prompts you to confirm that you want to edit the selected Phone Book entry.

From the Directory menu

- 1 Scroll and select *Edit*.**
A message prompts you for the Phone Book entry to edit.
- 2 Choose the Phone Book entry to edit by:**
 - Entering the memory location number, or
 - Scrolling to the location.
- 3 Push *Jog Dial*.**
A message prompts you to confirm that you want to edit the selected Phone Book entry.

- 4 Scroll and select name, Phone # or location #.**
- 5 Make the change, then push *Jog Dial*.**
Enter new information the same way you store information. If you want to cancel, press **CLR**.
- 6 Scroll and select *Save*.**
A message confirms that your changes have been saved.





Erasing Phone Book Entries

If the selected Phone Book entry is restricted, you must enter a four-digit lock code before you can erase it. You can erase Phone Book entries from the standby display or from the Directory menu. You can erase them one at a time, or erase your entire Phone Book.

From standby mode

- 1 Scroll down twice to access your Phone Book.
- 2 Scroll to the Phone Book entry you want to erase, then push *Jog Dial*.
- 3 Scroll and select **Erase**.
A message prompts you to confirm.
- 4 Push *Jog Dial* again to confirm.

From the Directory menu

- 1 Scroll and select **Erase**.
A message prompts you for the Phone Book entry to erase.
- 2 Choose the Phone Book entry to erase by:
 - Entering the memory location number, or
 - Scrolling to the location.A message prompts you to confirm.
- 3 Push *Jog Dial* again to confirm.

Erasing all Phone Book entries

- 1 From the Security menu, scroll and select **Erase Book**.
- 2 Press  to erase all Phone Book entries or push *Jog Dial* to quit without erasing.
If you erase all entries, a confirmation display appears. Be careful, there is no way to "undo" this function.



Restricting Phone Book Entries

You can restrict access to individual Phone Book entries or your entire Phone Book. Restricted entries display the message `Phone Book entry restricted` in place of the phone number. A lock code is required to view restricted numbers. If a restricted Phone Book entry is added to your Calls List, it's also restricted in your Calls List.

To restrict Phone Book entries

From the Phone Book

- 1 Scroll to the Phone Book entry you want to restrict, then push *Jog Dial*.
- 2 Scroll and select `Restriction`. Push *Jog Dial* to restrict the entry.

From the Security menu

- 1 Scroll and select `Restrict #`. You are prompted for the Phone Book entry to restrict.
- 2 Scroll to the Phone Book entry that you want to restrict, then push *Jog Dial*.



To unrestrict Phone Book entries



- 1 Scroll to the Phone Book entry you want to unrestrict, then push *Jog Dial*.
- 2 Scroll and select `Restriction`.
- 3 Enter the lock code to unrestrict the Phone Book entry.

To restrict all Phone Book entries

Turning off `Restrict All` will not unrestrict a Phone Book entry restricted individually.

- 1 From the Security menu, scroll and select `Restrict All`.
- 2 Scroll and select `on` or `off`.





Sounds Menu Settings

The Sounds menu allows you to adjust the volume of the ringer, keybeep and earpiece. You can also select the type of sounds heard when the phone rings and when you press keys.

Accessing the Sounds menu

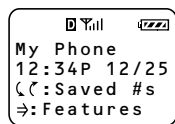

From standby, press **Jog Dial** to access the Features menu.

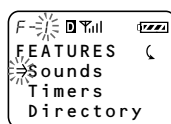

From Features, press **Jog Dial** to access the Sounds menu.

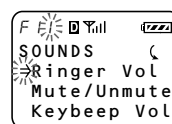

Sounds menu

Ringer

Ringer volume

This menu sets the ringer volume for all incoming calls. Manually adjust the ringer volume of individual incoming calls by turning Jog Dial.

- 1 Scroll and select **Ringer Vol..**
- 2 Scroll and select **off, low, med., high, escalate or vibrate.**

Note: You cannot set the ringer volume to escalate if your ringer type is a melody.

Ringer Off

If you select **off**, **-Ringer Off-** is displayed on the standby display and turning **Jog Dial** while the phone is ringing will not affect the ringer.

Ringer mute

You can quickly mute the ringer when you receive a call, but cannot take the call (e.g., during a meeting). While the phone is ringing, turn **Jog Dial** down or press **END** to mute the ringer. The unanswered call will be stored in the Calls List. Only the current call is muted; turn **Jog Dial** down or press **END** down to mute each additional call.





Ringer type

- 1 Scroll and select **Ringer Type**.
- 2 Scroll and select the ringer type.
You can select from ten different ringer settings. You can choose from five types of rings and five melodies. The ringer sounds every time you turn *Jog Dial*.

Message ringer

You can choose to be alerted when you receive new messages. See the section regarding carrier provided features.

Earpiece and microphone speakers

Earpiece volume

This menu sets the earpiece volume. You can easily adjust the earpiece volume during a call by turning *Jog Dial*.

- 1 Scroll and select **Earpiece Vol.**
- 2 Scroll and select the earpiece volume 1 (lowest) to 7 (highest).

Muting/unmuting the microphone

Quickly mute/unmute the microphone during a call directly by pushing and holding *Jog Dial*. You can also use the Sounds menu.

- 1 During a call, push *Jog Dial* to access the Features menu. Scroll and select **Sounds**. Scroll and select **Mute/UnMute**.
- 2 To unmute, push and hold *Jog Dial* for one second.





Keybeeps

Keybeeps are the sounds made by your phone's keys.

Keybeep type

This menu sets the sound to a click or tone (similar to DTMF tones). This setting does not affect DTMF tones sent to the other party.

- 1 **Scroll and select** Key Sound.
- 2 **Scroll and select** tones or clicks.

Keybeep volume

- 1 **Scroll and select** Keybeep Vol.
- 2 **Scroll and select** off, low, med. or high.

Keybeep length

This sets the length of the sound; what you hear and what the phone sends out (DTMF signals). The standard keybeep length is short, no matter how long you hold down the key. Long will send the tone as long as the key is held down.

- 1 **Scroll and select** Beep Length.
- 2 **Scroll and select** standard or long.



Display Menu Settings

You can use the features on the Display menu to change the appearance of the on-screen display. See page 20 for information regarding the Language selection menu.

Accessing the Display menu

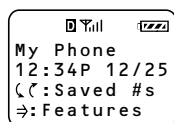

From standby, press **Jog Dial** to access the Features menu.

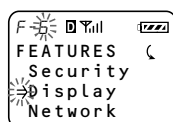

From Features, scroll and select Display.

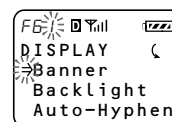

Display menu

Setting the banner

Your phone's display has one line (up to 12 characters) for you to personalize your standby display. This is called your banner.



- 1 **Scroll and select Banner.**
The current banner text is displayed.
- 2 **Push Jog Dial to change your banner.**
A message prompts you to enter a new banner.
- 3 **Use the keypad and Jog Dial to enter the new banner text.**
For details on character entry, see the "Alphanumeric table".
- 4 **Push Jog Dial to save the new banner.**



Setting the backlight

When you use the Jog Dial the backlight comes on automatically, but this menu sets how long your phone's backlight remains illuminated.

- 1 **Scroll and select Backlight.**
- 2 **Scroll and select 7 secs, for 15 secs, 30 secs or always off.**
An additional setting, *always on*, is available if you're using your phone with a hands-free car kit, a cigarette lighter adapter or a single- or dual-slot battery charger.





Setting autohyphenation

If autohyphenation is on, the phone assumes you're entering a U.S. phone number and enters a hyphen in the fourth and eighth spaces (e.g., North American Numbering Plan: eleven digits including a long distance identifier, three-digit area code, three-digit community code and four-digit location code, e.g., 999-999-9999).

- 1 Scroll and select **Auto-Hyphen**.
- 2 Scroll and select **on** or **off**.

Sorting the Phone Book

This menu determines how your Phone Book displays its entries and also how it sorts the entries (alphabetically or by memory location).

- 1 Scroll and select **Sort Book**.
- 2 Scroll and select **by loc. #** or **alphabetic**.



Message Format

You can choose how text messages appear on your display. See the section regarding carrier provided features.



Setting the menu length

This changes the menu from long to short. The long menu contains all of your phone's menus. However, once you've set your phone up, you may want to have access to just the few key menus included on the short menu.

- Ringer Vol.
- My Number
- Saved #s (submenus include: Find Name, Phone Book and Calls List.)
- Lock Phone
- Long Menu

- 1 Scroll and select **Menu Length**.
- 2 Scroll and select **short** or **long**.

To return to the long menu

- 1 From standby, press **Jog Dial** to access the Feature menu.
- 2 Scroll and select **Long Menu**.





Security Menu Settings

You can restrict access to your phone, reset to the default menu settings and store emergency numbers. You must enter a four-digit lock code to access the Security menu. A typical default lock code is either the last four digits of your phone number or 0000.

Access to the Security menu

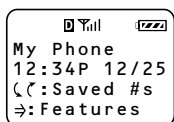

From standby, press **Jog Dial** to access the Features menu.

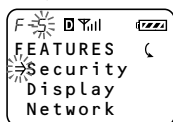

From Features, scroll and select **Security**, then enter the lock code.

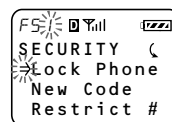

Security menu

Locking your phone

This menu locks your phone for low-level security. When locked, you can still answer incoming calls and dial 911 or other stored emergency numbers, but most operations require the lock code to be entered first.

- 1 **Scroll and select** Lock Phone.
- 2 **Scroll and select** never, on **POWER-UP** or right now.
If you select on **POWER-UP**, the phone is locked every time you turn it on.

To unlock the phone

The message "⇒:Unlock" indicates that the phone is locked.

- 1 **On the standby display, press Jog Dial.**
- 2 **Enter the lock code.**

Setting a new lock code

The lock code must be exactly four digits long.

- 1 **Scroll and select** New Code.
- 2 **Use the keypad to enter a lock code.**
- 3 **Push Jog Dial to store the new lock code.**
A confirmation message appears.

IMPORTANT

If you forget your lock code, contact your service provider.





Reverting to default settings

Reverting to the default settings does not affect Phone Book or Calls List entries.

- 1 **Scroll and select** *Master Reset*.
- 2 **Press**  **to revert to the factory defaults or push** *Jog Dial* **to keep the current settings.**

Storing emergency numbers

You can store up to three emergency numbers other than 911 (which you cannot erase).

- 1 **Scroll and select** *Emergency #*.
The first *Emergency #* display appears.
- 2 **Scroll and select** *Emergency #1*, *Emergency #2* or *Emergency #3*.
The phone prompts you to enter the emergency phone number.
- 3 **Use the keypad to enter the number, then push** *Jog Dial* **to store it.**
To go back to the standby display, hold down .





Network Menu Settings

You can set the phone to alert you when something happens to your network (roaming status change, call is dropped, enhanced voice privacy is lost). You can also activate/switch NAMs.

Accessing the Network menu

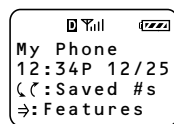

From standby, press **Jog Dial** to access the Features menu.

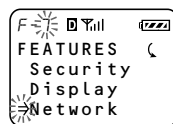

From Features, scroll and select Network.

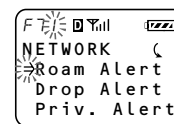

Network menu

Setting the phone's mode

You can determine whether your dual-band phone switches to analog mode when you roam off the Network. You have three options:

- Automatic (digital or analog) searches for digital service first, then analog service if digital could not be found.
- Disabled (digital only).
- Until OFF (analog only until phone is turned off).

1 Scroll and select Set Analog.

2 Scroll and select disabled, until OFF or automatic.

A message appears corresponding to the mode selected. Looking for Service is displayed. When established, a service area message is displayed followed by the standby screen.

System Preference

Activate the "Home Only" option to ensure that while you are in your home system area, your phone will bypass any other system's signal that may be stronger than your home system's signal. This option will help you to avoid higher costs or other calling problems.

1 Scroll and select System Pref.

2 Scroll and select standard or home only.





Setting the roaming alert

“Roaming” is when you use your phone outside of the home service area or other valid service areas. Roaming access to a different carrier and the types of calls you can make varies with the agreement between your “home” carrier and the current serving carrier. Check with your service provider for details.

- 1 Scroll and select **Roam Alert**.
- 2 Scroll and select **on** or **off**.

Your phone alerts you when you enter or leave valid service areas.

	On the display	If Roam Alert is on
Enter	roaming icon (R)	You'll hear a beep
Leave	Message Out-of-service icon (K)	You'll hear a beep

If you are in an analog roaming area

The message **Analog Roam** is displayed on the standby display when you're outside your home area and in an analog service area.



Setting the drop alert

If the signal fades, your phone may drop the ongoing call. If a call is dropped, you will see a message. If you turn Drop Alert on, you will also hear an audible alarm.

- 1 Scroll and select **Drop Alert**.
- 2 Scroll and select **on** or **off**.

Setting the voice privacy alert

The network automatically turns on enhanced voice privacy if it is available. You do not have to change your phone settings. For details, contact your service provider.

- 1 Scroll and select **Priv. Alert**.
- 2 Scroll and select **on** or **off**.

Enhanced voice privacy alerts

Your phone alerts you with display messages if enhanced voice privacy is lost or regained. In addition to the message, a beep sounds if you set the voice privacy alert on.





NAMS

NAMs are phone identifier numbers associated specifically with your phone. For example, your phone may have both a business phone number and also a personal phone number. You can store up to two NAM's (Number Assignment Modules) on your phone. To add or remove NAMs, contact your service provider who will change the NAMs for you.

Switching NAM's automatically

You can set your phone to switch between NAMs automatically when it enters a service provider's coverage area that matches one of your NAM settings.

- 1 **Scroll and select** `Auto-N.A.M.`.
- 2 **Scroll and select** `on` or `off`.

Switching NAM's manually

You can set your phone for manual switching between two NAMs. You must switch from one NAM to the other if the phone enters a service provider's coverage area that matches the other NAM setting. `Auto-N.A.M.` must be `OFF` to switch between NAMs manually.

- 1 **Scroll and select** `Set-N.A.M.`.
- 2 **Scroll and select** `NAM1` or `NAM2`.





Extras Menu Settings

On the Extras menu, you can set the phone to enable touch dialing, redial automatically and answer incoming calls automatically or at the press of any key. You can also use this menu to lock the keypad and to jot down phone numbers.

Accessing the Extras menu

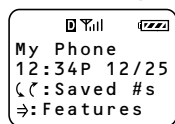

From standby, press **Jog Dial** to access the Features menu.



From Features, scroll and select Extras.

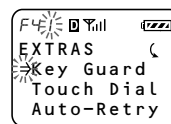

Extras menu

Preventing accidental operation

You can lock the keypad from the standby display or using the phone's menus. Locking the keypad offers low-level security. For example, it disables accidental dialing when you keep the phone in your pocket. Keyguard will remain active until the keypad is manually unlocked.



1 From standby mode
push and hold **Jog Dial**.

1 From the Extras menu,
scroll and select **Keyguard**.

To unlock the keypad

The keypad lock icon (🔒) and the text **Keyguard On** indicates that the keypad is locked. To turn the Keyguard off, press **1**, **2ABC** and **3DEF** in quick succession.

To answer an incoming call when the keypad is locked

Just press **SEND**. You do not need to unlock the keypad. When the call is ended, the phone automatically reverts to Keyguard On.





Checking and Setting the Timers

You can check call durations on the Timers menu. You can also set the phone to alert you every minute of a call and make the phone turn itself off automatically.

Accessing the Timers menu

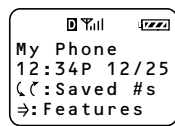

From standby, press **Jog Dial** to access the Features menu.

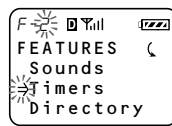

From Features, scroll and select **Timers**.

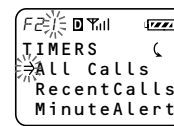

Timers menu

Checking the duration of all calls

You can view the total duration of all calls. This information cannot be reset.

- 1 Scroll and select **All Calls**.
- 2 Push **Jog Dial** to go back to the standby display.

Checking and resetting the duration of recent calls

You can view the total duration of your most recent calls.

- 1 Scroll and select **Recent Calls**.
- 2 Press **1** to reset, or hold down **CLR** to go back to the standby display.

If you choose to reset, the counter of recent calls and the corresponding durations are reset.

Checking and resetting the duration of roaming calls

You can view the total duration of your recent roaming calls.

- 1 Scroll and select **Roam Calls**.
- 2 Press **1** to reset, or hold down **CLR** to go back to the standby display.

If you choose to reset, the counter for roaming calls and the corresponding durations are reset.

48





Setting the minute alert

You can set the phone to sound an alert to help you monitor the length of your calls.

- 1 **Scroll and select** Minute Alert.
- 2 **Scroll and select** before min., each min., every 5 min. or off.

Setting the phone to turn off automatically

You can set the phone to automatically turn itself off. But, it will not turn itself off during a call. Once the phone turns off, the setting reverts to never.

The countdown timer

The countdown to auto-off appears on your standby display as Off:HH:MM:SS (hours: minutes: seconds) based on the setting selected. The timer counts down as long as the phone is idle. If you press any key or operate *Jog Dial*, the timer is reset and the countdown starts over.

- 1 **Scroll and select** Auto-Off.
- 2 **Scroll and select** never, in 3 hours, in 2 hours, in 1 hour or in 30 mins.
If you don't want the phone to turn off automatically, select never.





Short Messaging Service

Your phone is capable of many functions. However, some of these functions are dependent upon your service provider being able to support them. Check with your service provider to see which functions are supported in your area. One function, Short Messaging Service (SMS), allows you receive messages and store them in your phone's memory.

Receiving messages

Your phone is able to receive three different types of messages *text*, *voicemail* and *pages*. New messages are received whether your phone is on or off, but your phone can only alert you when it's on and within a service area.

When your phone is ON and within a service area	When your phone is OFF or outside a service area
<ul style="list-style-type: none"> •Message icon (✉) appears •A beep sounds •LED flashes (green or red) 	<p>New message(s) are stored but the display does not alert you. Alerts appear when you turn the phone on within a service area.</p>

The notification display

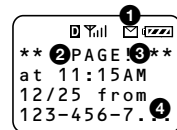

- 1 Envelope icon indicates you have unread messages
- 2 Text indicates the type of message
- 3 Asterisks and exclamation mark indicate urgency
- 4 Dots indicate the number is too long to fit on one line

The message icon

The message icon (✉) will remain on the display as long as you have unread messages.

Message beep

You can choose to have an audible sound to accompany the notification display when you receive a new message.

- 1 From the Sounds menu, scroll and select MessageBeep.
- 2 Scroll and select on, off or +reminder.



The LED

The LED alerts you that new messages have been received:

When the message is	LED
Non-urgent	Flashes green (quickly)
Urgent	Blinks red
Unread	Remains lit (green or red) until the message is read or for 15 minutes.

Clearing the message notification

To clear the notification, press **Jog Dial** or any key (except **PWR**).

Message storage capacity

Text messages and pages

A text message can be between 1 and 200 characters long. You can store approximately 7 large messages or 22 small messages.

Voice mail messages

Unlike text messages, voice mail messages are stored remotely by your service provider. Check with your service provider to find out the maximum number and length of voice mail messages you can store.

If memory becomes full

When the phone issues a warning that message memory is almost full, it's time to erase unnecessary messages (including locked messages). If your phone doesn't have enough memory to receive new messages, it attempts to free up memory by automatically erasing old unlocked messages. If it's unable to free up enough memory, new messages are rejected.

Carrier Provided
Features





Message format

Text messages received by your phone are just strings of characters. To make message reading easier, you can set your phone to format the text using one of the following settings:

Setting	How message is displayed	How text is affected
none	Exactly as received	Twelve consecutive characters are displayed on each line with every thirteenth character displayed on the next line regardless of word breaks.
partial	Long lines of text are wrapped without improper word breaks	If a word doesn't fit on the current line, the entire word is moved to the next line.
full	Long lines of text are wrapped. Extra spaces and lines are removed.	Text is read easily because it's wrapped, but it also keeps the text as compact as possible.



- 1 From the Display menu, scroll and select **Mss. Format**.
- 2 Scroll and select **none**, **partial** or **full**.



Accessing messages

- 1 Press **Ⓜ** from the standby display.
The Messages display appears indicating the number of messages found in each of the following mailboxes:
 - Voice mail messages.
 - Unread text messages and pagers.
 - Old text messages and pagers stored in memory.

Duplicate messages

If you receive the same message more than once, only the most recent duplicate message is stored and **Duplicate** is displayed next to it.

To erase a message

- 1 After reading a text message or listening to a voice mail message, push **Jog Dial**.
- 2 Scroll and select **Erase Mss.**
To go back to the Messages display without erasing the message, press **CLR**.





Text messages

A hollow box (□) indicates the end of the message. If you do not scroll, the display automatically scrolls down for you. After reading your text messages, protect or erase them.

To read new text messages

- 1 Scroll and select *New Text*.**
The first message is displayed. If there are no new messages, a display appears. Push Jog Dial to return to the Messages display.
- 2 Scroll through the message. To view the next message, push Jog Dial when you reach the end of the message.**
To return to the standby display, press **END**.
- 3 Scroll and select *Next Msg*.**
The next message is displayed. If there are no more messages, the Messages display reappears.

To read old messages

- 1 Scroll and select *Old Text*.**
- 2 Scroll through the list. When the message you want is displayed, push Jog Dial to read it.**
- 3 Scroll through the message. After reading the message, press **CLR** to return to the list of old messages.**
To return to the Messages display, press **M**. To read the next message, push Jog Dial, then select *Next Msg*.

To respond to a text message

- 1 After reading a text message, push Jog Dial.**
- 2 Scroll and select *Send*.**
The phone dials the callback phone number attached to the message. If there is no callback number attached, a message is displayed.

To protect a text message

- 1 After reading a message, push Jog Dial.**
- 2 Scroll and select *Lock Msg*.**
The message is now locked and protected from being erased.



To save the callback number

- 1 After reading a message, push Jog Dial.**
- 2 Scroll and select Save Number.**
The phone prompts you for a name to accompany the number.
- 3 Use the keypad to enter the name, then push Jog Dial to store the phone number and name.**
The phone prompts you to confirm the save.
- 4 Push Jog Dial to store the new number in the first available memory location.**
If you want to store it in another location, scroll to the desired location, then push Jog Dial. A confirmation message appears, followed by the status of the Phone Book.

To erase all old text messages

- 1 Scroll and select Erase Old.**
- 2 Press **1** to erase all old messages.**
To go back to the Messages display without erasing the messages, push Jog Dial.

Voice mail messages

- 1 Scroll and select Voice.**
A message appears indicating the number of messages stored in your voice mailbox. Press **CLR** to go back to the Messages display.
- 2 Scroll through the message.**
A hollow box (□) indicates the end of the message. After reading your messages, protect or erase them.

To dial a callback number

- 1 After reading a voice mail message, push Jog Dial.**
- 2 Scroll and select Send.**
The phone dials the callback number attached to the message.

54





Sending and Receiving Data

You are able to use your phone to send and receive electronic data (such as e-mail, faxes and WWW). Your phone can be set to convert digital signals (which are used by computers) to analog signals (which are used in telephone communication). This function enables your phone to act as a modem allowing it to send and receive computer communications.

However, this capability is dependent upon your service provider being able to support it. Check with your service provider to see which of the following electronic data functions are supported in your area.

Electronic data using your phone and a computer

To send and receive electronic data, just connect your phone to a computer using the Sony Interface Cable (QN-012DAS) or Desktop Charger Speakerphone (QN-023DCS). These accessories include a "Data Communication Guide" which provides detailed information regarding sending and receiving data. You can also download the guide from the Sony Wireless website at www.sony.com/wireless.



Sending data

As long as your phone is connected to a computer, sending data or fax calls from your phone doesn't require any special settings.

Receiving data

When your phone is connected to a computer and an incoming call is received, the **Recv. Data** setting tells your phone how to handle the transmission. It's best to turn this function off unless you are expecting to receive data or fax calls. If you choose fax, data/modem or PC control, your computer routes the data accordingly and normal voice calls aren't received. All settings except PC Control reset to off when you turn your phone off.

- 1 From the Extras menu, scroll and select **Recv. Data**.
- 2 Scroll and select **off, fax, data/modem or PC Control**.



Carrier Provided
Features





Unwired planet

As discussed on the previous page, your phone can be set to act as a modem for your computer allowing it to send and receive electronic data. However, with ***unwired planet***, your phone can actually bypass the computer component as well! Just think, send and receive computer communications such as e-mail, fax and WWW using just your phone!

Unwired planet relies on satellite signals to send and receive electronic data directly to your phone's display. However, ***unwired planet*** is dependent upon your service provider supporting this capability. Check with your provider to see if this service is available in your area.

Access to unwired planet

- 1 From standby, select **Features**.
- 2 Scroll and select **browser**.



What you'll see



Navigating and selecting

You'll still use Jog Dial to scroll through lists of items. However to navigate and select data, you'll see two choices on the bottom of the screen. The choice in the lower lefthand corner is always **OK** which selects the item indicated by the flashing arrow (=>). The second choice in the lower righthand corner is dependent on the current operation. To select the item indicated by the flashing arrow (=>), push and release Jog Dial when the word **OK** is surrounded by brackets. To select the other choice, hold down Jog Dial until the brackets surround the other choice.





Troubleshooting

Problem	Possible solutions	Page
Nothing appears on the display.	• The phone is off. Turn the phone on.	18
	• Battery is fully discharged. Recharge the battery.	16
	• Battery may not be completely attached. Securely attach the battery.	15
Out-of Service icon (⌘) appears.	• The phone is outside the service area or the signal is too weak. Extend the antenna fully.	18
	• Check NAM settings on the Network menu. If you set "Auto-NAM" to "off" and you are using two NAM's, the phone may be ignoring an available service.	74
Nothing happens when you press the keys.	• The keys may be locked.	56
	• The phone may be locked. Enter the lock code to unlock the phone.	60
The call does not go through.	• Check the signal strength.	18
	• If the out-of-service icon (⌘) is displayed, there is no service. See above.	18
	• Check the number.	21
	• Press SEND .	21
	• Listen for a busy signal.	—
You hear the caller, but the caller cannot hear you.	• The microphone may be muted. Unmute the microphone.	22, 42
You hear the caller only faintly.	• Adjust the earpiece volume. If possible, also reduce the noise around you.	22, 43
The call is cut off ("dropped").	• You are possibly out of the coverage area. Redial the number. If the problem continues, contact your carrier. Also see "Out-of-service icon (⌘) appears" above.	18
You hear an alternate high/low tone.	• You are attempting to use the phone in an area without service.	18
	• Extend the antenna fully.	18
	• Wait for the out-of-service icon (⌘) to disappear, then try to dial.	18
You forgot the lock code.	• Try 0000, 1234 (commonly used as defaults) or the last four digits of your own number. • See your authorized dealer or service provider.	60 —
You hear a fast busy tone.	• The fast busy tone can result from any one of the following problems:	—
	– The phone is improperly programmed.	18
	– The phone is out of range.	18
	– All channels are busy.	18
You cannot place or receive calls.	• The antenna is broken or damaged.	18
	• Make sure that the phone is turned on and that out-of-service icon (⌘) is not displayed.	18
	• Check system settings. If you are roaming, consult your service provider concerning roaming agreements.	71

Additional Information



Specifications

Frequency range		<u>Transmit (MHz)</u>	<u>Receive (MHz)</u>
	CDMA	1851.25 to 1908.75	1931.25 to 1988.75
	FM	824.04 to 848.97	869.04 to 893.97
Dimensions (h/w/d)	5.4 x 1.6 x 1.0 inches (146 x 50 x 37 mm) (not including antenna)		
Mass (weight)	Approx. 5 oz (218 g) (including battery)		
RF power output	CDMA	0.01 μ W to 550 mW	
	FM	6 mW to 600 mW	
Operational temperature	-22°F to +140°F (-30°C to +60°C) (excluding battery)		
Supplied accessories	QN-400BPL2 Extended Life Lithium-Ion Battery (1) QN-301TA Travel Adapter (1)		



Design and specifications are subject to change without notice.
Enhanced Variable Rate Codec available.





Optional Accessories

Call 1-800-447-8030 or visit our website to order additional accessories (USA only).

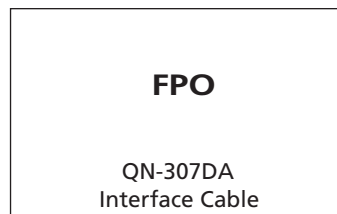
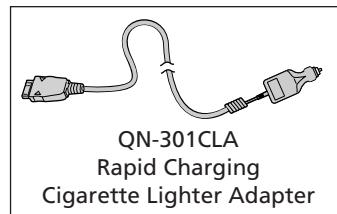
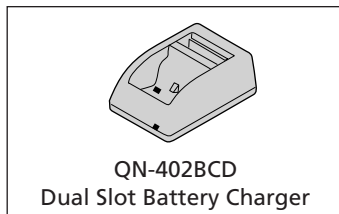
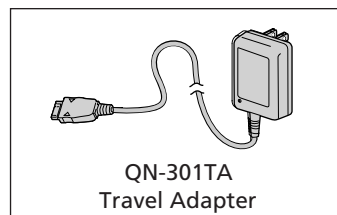
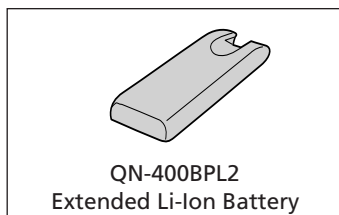
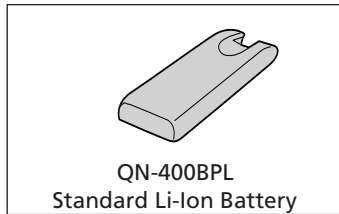

Additional Information



Rules and Regulations

The U.S. Federal Communications Commission and the Industry Canada regulate cellular/PCS telephone service in their respective countries. It is important for you, the cellular/PCS telephone user, to observe the applicable regulations when operating your cellular/PCS telephone in either country. In addition to these U.S. and Canadian federal regulations, you may be bound also by certain state, provincial, territorial, and local rules and regulations, as well as by your cellular/PCS carrier's tariff (the rates, terms, and conditions of its service). If you wish to use your cellular/PCS telephone in both the U.S. and Canada, please consult with your System Operator.

Furthermore, you should remember that your cellular/PCS telephone is a *radiotelephone*, — i.e., it combines both wireline technology, as used in your home or office telephone system, and radio technology — and that the scope of regulations and precautions is therefore broader than the scope of regulations and precautions relating to wireline-only telephone usage.

Some of the major points of consideration are set out below. Please note, however, that these "Rules and Regulations" and "Safety Precautions" sections do not constitute legal advice, and are intended merely for general information purposes. If you have specific questions, please contact your cellular/PCS carrier (System Operator).

License — If your home system is in the U.S., you do not require a separate license to operate your cellular/PCS telephone; obtaining a cellular/PCS telephone access number is sufficient to register you as a user. If your home system is in

Canada, a separate license is required; your carrier will assist you in the licensing process. If you wish to use your cellular/PCS telephone on both sides of the border, please contact your cellular/PCS carrier (System Operator).

Equipment modifications — The U.S. Federal Communications Commission has type-approved the model of cellular/PCS telephone which you have purchased, and has allocated a specific frequency range for cellular/PCS service. No changes or adjustments are to be made to your cellular/PCS telephone.

The radio equipment shall be made available for inspection upon request by representatives of the FCC or licensees.

Denial of service — A cellular/PCS carrier may deny service temporarily or terminate service for violation of any government regulations or violation of its tariff.

Privacy — As a telephone user, you have come to assume a certain standard of privacy when you place or receive a telephone call via the traditional wireline systems. However, because cellular/PCS telephones utilize radio transmissions to effect calls, the same standard cannot always be assured. While it is unlawful for any unauthorized person to divulge or use any information obtained from intercepting or "listening in on" conversations intended for others, you should not assume that your conversation is completely secure. Commercially available scanning equipment can permit a third party to monitor the radio channels used for cellular/PCS telephone calls.

Interference — No person shall interfere with, or cause interference to, any radio communication or signal.



Safety Precautions

IMPORTANT

For safe and efficient operation of your phone, observe these guidelines.

Your dual band (analog/digital CDMA) hand-held portable cellular/PCS telephone uses both analog frequency modulation (FM) technology and digital Code Division Multiple Access (CDMA) technology. CDMA is a newer radio frequency (RF) technology than the FM technology that has been used for radio communications for decades.

Your dual band portable cellular/PCS telephone is a radio transmitter and receiver. When the phone is ON, it receives and sends out radio frequency (RF) energy. The phone operates in the frequency range of 800 MHz in analog mode and 1.9 GHz in digital CDMA mode. When you use your phone, the cellular/PCS system handling your call controls the mode of operation (analog or digital CDMA) and the power level at which your phone transmits. In the analog mode, the power is continuously transmitted at a level that can range from about 6 mW to about 600 mW. In the digital CDMA mode, the power is transmitted as a digitally coded waveform at a rate varying from 100 Hz to 800 Hz. The average power can range from about 0.01 μW to about 300 mW.

Exposure to radio frequency energy

Research on health effects from RF energy has focused for many years on FM radio technology. That research and studies regarding newer radio technologies, such as CDMA, have found no credible

scientific evidence that adverse health effects result from the use of cellular/PCS telephones.

The Institute of Electrical and Electronics Engineers (IEEE) in 1991, and The American National Standards Institute (ANSI) in 1992, updated the 1982 ANSI Standard for safety levels with respect to human exposure to RF energy. Over 120 scientists, engineers, and physicians from universities, government health agencies, and industry, reviewed the available research and developed this updated Standard. In March 1993, the U.S. Federal Communications Commission (FCC) proposed the adoption of this updated Standard.

The design of your phone complies with this updated Standard. Of course, if you want to limit RF exposure even further than the updated ANSI Standard, you may choose to control the duration of your calls and operate your phone in the most power efficient manner.

Efficient phone operation

For your phone to operate at the lowest power level consistent with satisfactory call quality, please observe the following guidelines:

Your phone has an extendable antenna; extend it fully whenever possible for maximum efficiency.

Hold the phone as you would any other telephone. While speaking directly into the mouthpiece, position the antenna up and over your shoulder.

Do not hold the antenna when the phone is in use. Holding the antenna affects call quality and may cause the phone to operate at a higher power level than needed.

Additional Information



Heat and sunlight exposure

Avoid leaving your cellular/PCS phone exposed to direct sunlight or extreme heat. Extended exposure to heat and sunlight may damage the components of your cellular/PCS phone.

Antenna care and replacement

Do not use the phone with a damaged antenna. If a damaged antenna comes into contact with the skin, a minor burn may result. Replace a damaged antenna immediately. Take your phone to an authorized service center for repair.

Use only the supplied or approved antenna. Unauthorized antennas, modifications, or attachments could impair call quality, damage the phone, and violate FCC regulations.

Driving

Check the laws and regulations on the use of cellular/PCS telephones in the areas where you drive. Always obey them. Also, when using your phone while driving, please:

- pay full attention to driving;
- use hands-free operation, if available;
- pull off the road and park before making or answering a call, if driving conditions so require.

Electronic devices

Most modern electronic equipment is shielded from RF energy. However, RF energy from cellular/PCS telephones may affect some electronic equipment.

RF energy may affect improperly installed or inadequately shielded electronic operating and entertainment systems in motor vehicles. Check with the manufacturer or its representative to determine if these systems are adequately shielded from external RF energy. You should also check with the manufacturer of any equipment that has been added to your vehicle.

Medical devices

Consult the manufacturer of any personal medical devices (such as pacemakers, hearing aids, etc.) to determine if they are adequately shielded from external RF energy. Your physician may be able to assist you in obtaining this information.

Turn your phone OFF in health care facilities when regulations posted in the areas instruct you to do so. Hospitals or health care facilities may be using equipment that could be sensitive to external RF energy.

Aircraft

Turn your phone OFF before boarding any aircraft.

- Use it on the ground only with crew permission.
- Do not use in the air.

To prevent possible interference with aircraft systems, U.S. Federal Aviation Administration (FAA) regulations require you to have permission from a crew member to use your phone while the plane is on the ground. To prevent interference with aircraft communication systems, FCC regulations prohibit using your phone while the plane is in the air.





Children

Do not allow children to play with your phone. It is not a toy. Children could hurt themselves or others (by poking themselves or others in the eye with the antenna, for example). Children also could damage the phone or make calls that increase your telephone bill.

Blasting areas

To avoid interfering with blasting operations, turn your unit OFF when in a "blasting area" or in areas posted: "Turn off two-way radio." Construction crews often use remote control RF devices to set off explosives.

Potentially explosive atmospheres

Turn your phone OFF when in any area with a potentially explosive atmosphere. It is rare, but your phone or its accessories could generate sparks. Sparks in such areas could cause an explosion or fire resulting in bodily injury or even death.

Areas with a potentially explosive atmosphere are often, but not always, clearly marked. They include fueling areas such as gas stations; below deck on boats; fuel or chemical transfer or storage facilities; areas where the air contains chemicals or particles, such as grain, dust or metal powders; and any other area where you would normally be advised to turn off your vehicle's engine.

Do not transport or store flammable gas, liquid or explosives in the compartment of your vehicle which contains your phone or accessories.

In the United States, vehicles using liquefied petroleum gas (such as propane or butane) must comply with the National Fire Protection Standard (NFPA-58). For a copy of this standard, contact the National Fire Protection Association, One Batterymarch Park, Quincy, MA 02269, Attn: Publication Sales Division.

In Canada, vehicles using liquefied petroleum gas (such as propane or butane) must comply with the Canadian Gas Association (CAN/CGS-B149.2). For a copy of this standard, contact the Canadian Standards Association, 178 Rexdale Blvd., Etobicoke, ON M9W 1R3, Attn.: Standard Sales Department.



Additional
Information





Glossary

Alphanumeric table

Allows you to enter characters on your phone's display.

AnyKey Answer

Allows you to answer your incoming calls with any key except power.

Autohyphenation

Automatically hyphens the phone number as you enter the digits.

Backlight

The light that illuminates the display on your phone.

Banner

Message at the top of the standby display.

Calls List

A list of your 10 most recent calls.

Carrier

A company that provides cellular and PCS telephone service.

CDMA

Code Division Multiple Access. A spread-spectrum approach to digital transmission. With CDMA, each conversation is digitized and then tagged with a code. The mobile phone receives only the signal with the appropriate code.

Coverage area

The geographic area covered by one carrier. If you travel outside a carrier's area, you cannot receive service from that carrier. Also see "Roam".

Dropped call

A call terminated because of a deep, long fade or because the user left the coverage area.

DTMF

Dual Tone Multiple Frequency, also known as "touch-tone". Tone generated when you press a telephone key (number, * or #). Can be used to access answering machines, pagers, telephone banking services, data services and other electronic services.

ESN

Electronic Serial Number. The unique identification number of your telephone. The telephone transmits this number to the base station every time a call is placed.

Home area

The area of the home system to which you subscribe.

Keypad

A feature that allows you to lock the phone's keypad for low level security.

Lock Phone

Protects your phone from accidental key presses or unauthorized access to your phone.

Minute Alert

A feature that helps you keep track of the time you spend on the phone, by beeping every 10 seconds before the minute.

NAM

Number Assignment Module. Portion of your telephone's memory programmed to contain information about your subscription to the carrier. Your telephone can have up to two NAM's.



NAM, automatic

Feature that automatically selects an available NAM that matches the current serving system (carrier).

NAM, multiple registration

Registering your phone in more than one carrier. A cheaper alternative to roaming. If you travel frequently to a specific area, registering the local carrier in your phone's NAM's may be an economical alternative to roaming and long distance charges.

OTASP

Allows you to self-activate with new service. Check with your service provider for details.

Pause

You can insert a Time Pause or Hard Pause in the phone number memory data. A pause causes the phone to wait (either for a specified time or until manually released) before sending a second string of digits, ensuring your counterpart (e.g., answering machine, voice mail system, electronic banking system, etc.) is ready to accept the string.

Pauses and links

Phone Book

You can store up to 99 numbers in Phone Book memory, location number 01 to number 99.

Prefixing

To add an area code to an existing number in the Phone Book.

Redial

Set your phone to automatically redial when the first attempt doesn't go through (e.g., no answer or busy signal).

Roam

Your phone is roaming when you use it outside of the home area. Availability of roaming access to a different carrier and types of calls you can make varies with the agreement between your home carrier and serving carrier. Check with your carrier for details about roaming in a specific area.

Scratch pad

Allows you to enter a number and store it in the Calls List.

Service area

Region covered by a cellular/PCS service. Also see "Coverage area".

SMS

Short Messaging Service. An extended service offered by carriers that allows you to receive text messages on your phone. Check with your carrier for details.

Speed dialing

Making a call using Phone Book memory locations.

Touch dialing

A quick way of making a call using a number stored in a Phone Book memory location.

Voice mail

An extended service, offered by carriers, that allows you to retrieve voice mail messages stored in your voice mailbox. Check with your carrier for details.

Additional
Information





Index

A

AC adapter 10, 16
Accessories, optional 54
Adjusting volume
 Earpiece 18
 Ringer 21
Alerts
 Analog roam 41
 Drop 42
 Minute 47
 Privacy 42
Alphanumeric table 16
Antenna 7, 10
Any Key Answer.see Functions
Automatic
 Answer 58
 Hyphenation 68
 Power off 47
 Redial 57
 Retry 57

B

Backlight 67
Banner 66
Battery
 Attaching/removing 8
 Charge contacts 16
 Charging 8
 Checking 9
 Duration 9
 Icon 16, 17
 Release tab 7

C

Caller ID 23
Calls, duration 46
Calls, making
 Basic 18
 From your Calls List 36, 55
 From your Phone Book 19
 Limiting
 Prefixing 22
 Recent number 36
 Redialing 22, 57
 Restricting 30, 62, 63
 Roaming 71
 Speed dialing 32
 Touch dialing 32, 57
Calls, in progress
 Dropped call 72
 Ending calls 21, 23
Calls, missed 24
Calls, receiving 21
Carrier 71
CDMA (Code Division
 Multiple Access) 5
Character display 11
Clearing. *See* Deleting
Connector 7
Coverage area 71
Cursor 25, 49



D

- Dialing. *See* Calls
- Default settings, reverting 39
- Deleting
 - Calls List entries 65
 - Characters 29, 50
 - Message 83
 - Phone Book entries 29, 50
 - Phone Book, entire 31
 - Text messages 23
 - Voice mail 84
- Digital icon 14
- Display 11
- Display settings
 - Accessing 39
 - Autohyphenation 68
 - Backlight 67
 - Banner 66
 - Time 45
- Displaying overflow digits 23
- Displays
 - Calling 21
 - Features menu 39
 - Hyphens/pauses/links 27
 - Menu setting 69
 - Security 60
 - Standby 18
- Dropped call 41
- DTMF (Dual Tone Multiple Frequency)
 - Attached to pauses and links 27
 - Sending manually 27

E

- Earpiece 22, 43
- Editing
 - Emergency numbers 65
 - Phone Book entries 28, 51
- Emergency numbers 39
- Enabling
 - Lock 56
 - Touch dialing 57
- Ending a call 21, 23
- Entering
 - Digits and letters 23
 - Hyphens 27
 - Links 27
 - Pauses 27
- Erasing. *See* Deleting
- ESN (Electronic Serial Number) 90

F

- Finding. *See* Searching
- Functions
 - Any Key Answer 23
 - Autohyphenation 23
 - Auto Redial 23
 - Limit calls 23
 - Prefixing 23
 - Touch dial 23

H

- Home Only 76
- Hyphens
 - Autohyphenation 68
 - Entering manually 27

Additional Information





I

Incoming call 23
Icon
 Battery 11
 Digital 11
 In-use 10, 11, 21, 23
 Message 11
 Roam 11
 Out-of service 10, 11
 Signal strength 10, 11

J

Jog Dial 19

K

Key, arrow/* 7
Key, arrow/# 7
Key, clear 7
Key, end 7
Key, message 7
Key, number 7
Key, power 7
Key, send 7
Keybeep
 Length 35
 Type 35
 Volume 22
Keyguard 56
Keypad lock icon 56

L

Language selection 20
Laws
 Rules and regulations 3
Limit calls 20
Link 27
List of menu items 15
Lock code 39
Locking the keypad 44
Locking your phone 38

M

Making calls 21
 answer manually 23
 call 21
 Hyphenation 27
 Redial 22
Memory
 Deleting 29, 50
 Editing 28, 51
 Number searching 33, 52, 53
 Storing 25, 48
Menu
 Display 36
 Extras xx
 Network 40
 Security xx
 Timers 46
 Volume xx
Menu items 15
Menu language 20
Menu Map 14
Menus access 39
Message key 78
Message icon 77
Messages
 Access 49
 Format 49
 Full memory 48
 Message list 79
 Receiving 48
 Storage capacity 48
Messages, text
 Displaying new 50
 Displaying old 50
 Erasing 51
 Locking 51
 Responding 50
 Saving the callback 51
Messages, voice mail
 Dialing callback 49
 Displaying 48
 Erasing 49
 Locking 80
 Receiving 48
Microphone 7, 22, 42
Minute alert 46
Multiple city registration 91
Muting the microphone 22, 42
Muting the ringer 23, 41





=====**N**=====

NAM (Number Assignment Module), switching
 Automatically 70, 74
 Manually 42
 Number keys 21, 25

=====**O**=====

Out-of-service icon 18, 21, 23, 71
 Over-the-Air Service Provisioning (OTASP) 7
 Overflow digits 37

=====**P**=====

Pause 27
 Phone Book 25, 31, 33, 48
 Calling 21
 Deleting 29
 Limiting calls 22
 Restricting/unrestricting 32
 Phone number, yours 17
 Power
 Turning off 10, 18, 47
 Turning on 10, 18
 Prefixing 22
 Privacy alert 42

=====**Q**=====

Quitting. *See* Power

=====**R**=====

Receiving
 Calls 23
 text messages 77
 Voice mail 83
 Recent number memory
 Calling recent numbers 36
 Clearing call memory 64
 Redialing
 Auto-retry 57
 Last dialed number 18
 Restriction 30, 62, 63
 Reverting to default settings 11
 Ringer
 Speaker 7, 12, 13
 Type 35
 Volume 41
 Roam
 Alert 41
 Analog 41
 Roam icon 71
 Roaming agreement 71
 Rules and regulations 55



Additional Information





===== S =====

Safety precautions 55
Saving
 Emergency numbers 39
 To the Phone Book 25
Scratch pad 59
Scrolling
 Menus 19
 Message 79, 80
 Message list 80
Searching
 Alphabetically 28
 By memory location 29
 For a message 80
 For a name 52
 For a phone number 33-35
Security code. *See* Security functions
Security functions
 Accessing 60
 Clearing call memory 64
 Emergency numbers 65
 Lock phone 60
 New lock code 61
 Restriction 62, 63
Sending. *See* Calling
Service area 71
Settings
 Display xx
 Extras 44
 Menu length 37
 Network 40
 Phone's mode 40
 Timers 47
 Security 38
 Volume 38
Signal strength icon 18
SMS (Short Messaging Service) 48
 Message format 77
Sorting the Phone Book 37
Special characters 20

70

Special features
 Accessing 56
 Changing DTMF transmission 44
 Enabling touch dialing 57
 Muting the microphone 42, 22
 Muting the ringer 23, 41
 Setting auto-answer 58
 Setting auto-retry 58
 Using the scratch pad 59
Specifications 53
Standby display 18
Storing. *see* Saving.
System preference 76
System settings
 Accessing 70
 Analog 70
 Over-the-Air Service Provisioning (OTASP) 75
 Selecting NAM's
 Auto-NAM 74
 Manual NAM 74

===== T =====

Text Message. *See* Messages
Touch dialing
 Enabling 57
Troubleshooting 52
Turning phone on 18

===== U =====

Unlocking your phone 38

===== V =====

Viewing additional info 24
Voice mail notification
 Accessing 84
 Receiving 84
Voice Privacy 73
Volume, setting and adjusting
 Earpiece 41
 Keybeep 34
 Ringer 71





SONY

CELLULAR/PCS TELEPHONE
CELLULAR/PCS TELEPHONE ACCESSORIES

LIMITED WARRANTY

SONY ELECTRONICS INC. ("SONY") warrants this Product and its accessories against defects in material or workmanship as follows:

1. **PRODUCTS:** For a period of one (1) year from the date of purchase, SONY will, at its option, either pay the parts and labor charges to any SONY authorized Cellular/PCS telephone service facility to repair or replace the defective Product (with new or rebuilt replacements). After this one (1) year period, you must pay all parts, shipping, and labor charges.

2. **ACCESSORIES:** For a period of one (1) year from the date of purchase, SONY will, at its option, either pay the parts and labor charges to any SONY authorized Cellular/PCS telephone service facility to repair or replace defective accessories (i.e.; cables, casings, straps, batteries, etc.) with new or rebuilt replacements. After this one (1) year period, you must pay all parts, shipping, and labor charges. This warranty is not valid for any battery if (i) it has been charged by other than a SONY approved battery charger specified for the charging of the battery, (ii) any of the seals on the battery are broken or show evidence of tampering, or (iii) the battery has been used in equipment other than the Cellular/PCS telephone product for which it is specified.

3. **REPAIRS:** For a period equal to the remainder of the original limited warranty period on the original Product or accessory, or for 90 days after the date of repair/replacement, whichever is longer, SONY will repair or replace (with new or rebuilt replacements) defective parts, accessories and/or Products used in the repair or replacement of Products or accessories under this Limited Warranty.

To obtain warranty service, contact SONY WIRELESS HOTLINE or your local service provider.

This warranty does not cover customer education, instruction, installation, set up adjustments, or signal reception problems.

This warranty does not cover cost of removal or reinstallation, cosmetic damage or damage due to acts of God, accident, misuse, abuse, negligence, or modification of, or to any part of the Product, including the antenna. This warranty does not cover lost profits, lost sales, loss of use of the Product, or other consequential loss (e.g., airtime charges during the malfunction of the Product or accessory), damage due to improper operation or maintenance, installation, connection to improper voltage supply or attempted repair of the Product or accessories by anyone other than a facility authorized by SONY. This warranty does not cover Products sold AS IS or WITH ALL FAULTS, or consumables (such as fuses). This warranty does not apply when the malfunction results from use of the Product in conjunction with accessories, products or ancillary or peripheral equipment not manufactured by SONY, and where it is determined by SONY that there is no fault with the Product itself.

This warranty is valid only in the United States.

Proof of purchase in the form of a bill of sale or receipted invoice, which is evidence that the unit is within the warranty period must be presented to obtain warranty service.

This warranty is invalid if the factory-applied serial number has been altered or removed from the Product or accessory.

REPAIR OR REPLACEMENT AS PROVIDED UNDER THIS WARRANTY IS THE EXCLUSIVE REMEDY OF THE CONSUMER. SONY SHALL NOT BE LIABLE FOR ANY INCIDENTAL OR CONSEQUENTIAL DAMAGES FOR BREACH OF ANY EXPRESS OR IMPLIED WARRANTY ON THIS PRODUCT OR ACCESSORY. EXCEPT TO THE EXTENT PROHIBITED BY APPLICABLE LAW, ANY IMPLIED WARRANTY OF MERCHANTABILITY OR FITNESS FOR A PARTICULAR PURPOSE ON THIS PRODUCT OR ACCESSORY IS LIMITED IN DURATION TO THE DURATION OF THIS WARRANTY.

Some states do not allow the exclusion or limitation of incidental or consequential damages, or allow limitations on how long an implied warranty lasts, so the above limitations or exclusions may not apply to you. This warranty gives you specific legal rights, and you may have other rights which vary from state to state.

FOR FREQUENTLY CALLED TELEPHONE NUMBERS, PLEASE SEE REVERSE SIDE.



For your convenience, SONY ELECTRONICS INC. has established
telephone numbers for product information regarding
CELLULAR/PCS telephones.

Please call:

SONY WIRELESS HOTLINE
1-800-578-SONY (7669)

or write to:
SONY Customer Information Center
One Sony Drive
Park Ridge, New Jersey 07656-8003

For an accessory or part not available from your authorized dealer,
call:

1-800-488-SONY (7669)

or

1-816-891-2553



**FOR WARRANTY INFORMATION ON YOUR PURCHASE,
PLEASE SEE REVERSE SIDE.**





SONY

3-xxx-xxx-xx
80-xxxxx-x

Quick Reference Card

CM-SB200

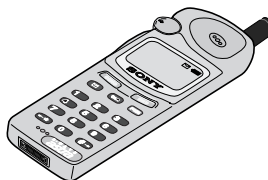

Sony Electronics Inc. 1999

Printed in USA

The Basics

ON/OFF Hold down **(PWR)** for one second

Call Enter a phone number then press **(SEND)**

Answer Press **(SEND)**

Disconnect Press **(END)**

Redial Press **(SEND)**

Volume Adjustments

Ringer While it's ringing, turn Jog Dial

Earpiece During a call, turn Jog Dial

Mute/Unmute During a call, press and hold Jog Dial

Security

Keypad Lock Hold down Jog Dial (from standby mode)

Keypad Unlock Press **(1)** **(2 ABC)** **(3 DEF)**

Locking the phone (settings: never, right now or on Power Up)

From Long Features menu **From Short Features menu**

1 Scroll / select Security 1 Scroll / select Lock Phone

2 Enter lock code 2 Enter lock code

3 Select Lock Phone 3 Scroll / select setting

4 Scroll / select setting

Setting a New Lock Code (from Long Features menu)

1 Scroll / select Security; enter current lock code

2 Scroll / select New Code

3 Enter new lock code; push Jog Dial



**Memory
Phone Book**

- Storing**
- 1 Enter a phone number, then push
 - 2 Scroll & select **Save**
 - 3 Enter a name, then push twice

Calling

- Touch Dial** Enter the memory location # and hold down the last digit
- Speed Dial** Enter the memory location #, press **SEND**
- Fast 4 Dial** Enter the last 4 digits of an entry, press **SEND**
- Manually** Scroll/select an entry, then push twice

Searching

- Quick Alphabetic** Press the key that corresponds with the first letter of the name you want to find
- Find Name**
- 1 Turn down to access the phone book
 - 2 Push to select **Find Name**
 - 3 Enter a name, then push

Calls List

- Calling**
- 1 Turn up twice to access the Calls List
 - 2 Scroll/select an entry, then push twice
- Saving**
- 1 Scroll & select an entry, then push
 - 2 Scroll & select **Save**
 - 3 Enter a name, then push twice

Miscellaneous

- Outbound call restriction** (settings: off, to loc 99, to loc 199)
- 1 Push to access the **Features** menu
 - 2 Scroll & select **Security**; enter lock code
 - 3 Scroll & select **Limit Calls**
 - 4 Scroll & select setting

What's my phone number?

- | | |
|--------------------------------------|--------------------------|
| Long Menu | Short Menu |
| 1 Select Features | 1 Select Features |
| 2 Scroll & select Directory | 2 Scroll & select |
| 3 Scroll & select My Number . | My Number |

Push Jog Dial in Turn Jog Dial down Turn Jog Dial up







SONY Wireless Hotline Number (USA only)

If you have any questions or comments, please call:
SONY WIRELESS HOTLINE
1-800-578-SONY (7669)

Visit our website at www.sony.com/wireless
to register your product online and
find out about additional Sony technology

Printed in USA

