



SONY[®]

3-861-742-12
80-68385-6

Portable Dual Band PCS Telephone

Operating Instructions



D · W A V E
astra

CM-B1200
CM-B2200
CM-B3200



Before operating your portable dual band telephone, please read this manual thoroughly and retain it for future reference.

If your usage includes in-vehicle operation, it is recommended that you refer to the Installation/Connections/Operation manual for the optional accessory kits.

DISPOSAL OF LITHIUM ION BATTERY

LITHIUM ION BATTERY. DISPOSE OF PROPERLY.

You can return your unwanted lithium ion batteries to your nearest Sony Service Center or Factory Service Center.

Note: In some areas the disposal of lithium ion batteries in household or business trash may be prohibited.

For the Sony Service Center nearest you call 1-800-222-SONY (United States only).

For the Sony Factory Service Center nearest you call 416-499-SONY (Canada only).

WARNING

To prevent fire or shock hazard, do not expose the unit to rain or moisture.

FCC CAUTION STATEMENT

You are cautioned that any changes or modifications not expressly approved in this manual could void your authority to operate this equipment.

Owner's record

The model number, regulatory number, and serial number are located on a nameplate inside the battery compartment. Record the serial number in the space provided below. Refer to these numbers whenever you call your dealer regarding this product.

Model No.: _____ Serial No.: _____

©1998 Sony Electronics Inc. All rights reserved. Reproduction without written consent expressly prohibited. Sony, Jog Dial, D-WAVE logo and D-WAVE Astra are trademarks of Sony. Third party trademarks are the property of their respective holders. Design and specifications are subject to change without notice. Talk and standby times are subject to change.





Rules and regulations

The U.S. Federal Communications Commission and the Industry Canada regulate cellular/PCS telephone service in their respective countries. It is important for you, the cellular/PCS telephone user, to observe the applicable regulations when operating your cellular/PCS telephone in either country. In addition to these U.S. and Canadian federal regulations, you may be bound also by certain state, provincial, territorial, and local rules and regulations, as well as by your cellular/PCS carrier's tariff (the rates, terms, and conditions of its service). If you wish to use your cellular/PCS telephone in both the U.S. and Canada, please consult with your System Operator.

Furthermore, you should remember that your cellular/PCS telephone is a *radiotelephone*, — i.e., it combines both wireline technology, as used in your home or office telephone system, *and* radio technology — and that the scope of regulations and precautions is therefore broader than the scope of regulations and precautions relating to wireline-only telephone usage.

Some of the major points of consideration are set out below. Please note, however, that these "Rules and Regulations" and "Safety Precautions" sections do not constitute legal advice, and are intended merely for general

information purposes. If you have specific questions, please contact your cellular/PCS carrier (System Operator).

License — If your home system is in the U.S., you do not require a separate license to operate your cellular/PCS telephone; obtaining a cellular/PCS telephone access number is sufficient to register you as a user. If your home system is in Canada, a separate license is required; your carrier will assist you in the licensing process. If you wish to use your cellular/PCS telephone on both sides of the border, please contact your cellular/PCS carrier (System Operator).

Equipment modifications — The U.S. Federal Communications Commission has type-approved the model of cellular/PCS telephone which you have purchased, and has allocated a specific frequency range for cellular/PCS service. No changes or adjustments are to be made to your cellular/PCS telephone.

The radio equipment shall be made available for inspection upon request by representatives of the FCC or licensees.

Denial of service — A cellular/PCS carrier may deny service temporarily or terminate service for violation of any government regulations or violation of its tariff.





Privacy — As a telephone user, you have come to assume a certain standard of privacy when you place or receive a telephone call via the traditional wireline systems. However, because cellular/PCS telephones utilize radio transmissions to effect calls, the same standard cannot always be assured. While it is unlawful for any unauthorized person to divulge or use any information obtained from intercepting or “listening in on” conversations intended for others, you should not assume that your conversation is completely secure. Commercially available scanning equipment can permit a third party to monitor the radio channels used for cellular/PCS telephone calls.

Interference — No person shall interfere with, or cause interference to, any radio communication or signal.



Safety precautions

IMPORTANT

For safe and efficient operation of your phone, observe these guidelines.

Your dual band (analog/digital CDMA) hand-held portable cellular/PCS telephone uses both analog frequency modulation (FM) technology and digital Code Division Multiple Access (CDMA) technology. CDMA is a newer radio frequency (RF) technology than the FM technology that has been used for radio communications for decades.

Your dual band portable cellular/PCS telephone is a radio transmitter and receiver. When the phone is ON, it receives and sends out radio frequency (RF) energy. The phone operates in the frequency range of 824 MHz to 894 MHz in analog mode, and 1851 MHz to 1989 MHz in digital CDMA mode. When you use your phone, the cellular/PCS system handling your call controls the mode of operation (analog or digital CDMA) and the power level at which your phone transmits. In the analog mode, the power is continuously transmitted at a level that can range from about 6 mW to about 600 mW. In the digital CDMA mode, the power is transmitted as a digitally coded waveform at a rate varying from 100 Hz to 800 Hz. The average power can range from about 0.01 μ W to about 300 mW.

Exposure to radio frequency energy

Research on health effects from RF energy has focused for many years on FM radio technology. That research and studies regarding newer radio technologies, such as CDMA, have found no credible scientific evidence that adverse health effects result from the use of cellular/PCS telephones.

The Institute of Electrical and Electronics Engineers (IEEE) in 1991, and The American National Standards Institute (ANSI) in 1992, updated the 1982 ANSI Standard for safety levels with respect to human exposure to RF energy. Over 120 scientists, engineers, and physicians from universities, government health agencies, and industry, reviewed the available research and developed this updated Standard. In March 1993, the U.S. Federal Communications Commission (FCC) proposed the adoption of this updated Standard.

The design of your phone complies with this updated Standard. Of course, if you want to limit RF exposure even further than the updated ANSI Standard, you may choose to control the duration of your calls and operate your phone in the most power efficient manner.



Efficient phone operation

For your phone to operate at the lowest power level consistent with satisfactory call quality, please observe the following guidelines:

Your phone has an extendable antenna; extend it fully whenever possible for maximum efficiency.

Hold the phone as you would any other telephone. While speaking directly into the mouthpiece, position the antenna up and over your shoulder.

Do not hold the antenna when the phone is in use. Holding the antenna affects call quality and may cause the phone to operate at a higher power level than needed.

Heat and sunlight exposure

Avoid leaving your cellular/PCS phone exposed to direct sunlight or extreme heat. Extended exposure to heat and sunlight may damage the components of your cellular/PCS phone.

Antenna care and replacement

Do not use the phone with a damaged antenna. If a damaged antenna comes into contact with the skin, a minor burn may result. Replace a damaged antenna immediately. Take your phone to an authorized service center for repair.

Use only the supplied or approved antenna. Unauthorized antennas, modifications, or attachments could impair call quality, damage the phone, and violate FCC regulations.

Driving

Check the laws and regulations on the use of cellular/PCS telephones in the areas where you drive.

Always obey them. Also, when using your phone while driving, please:

- pay full attention to driving;
- use hands-free operation, if available;
- pull off the road and park before making or answering a call, if driving conditions so require.

Electronic devices

Most modern electronic equipment is shielded from RF energy. However, RF energy from cellular/PCS telephones may affect some electronic equipment.

RF energy may affect improperly installed or inadequately shielded electronic operating and entertainment systems in motor vehicles. Check with the manufacturer or its representative to determine if these systems are adequately shielded from external RF energy. You should also check with the manufacturer of any equipment that has been added to your vehicle.





Medical devices

Consult the manufacturer of any personal medical devices (such as pacemakers, hearing aids, etc.) to determine if they are adequately shielded from external RF energy. Your physician may be able to assist you in obtaining this information.

Turn your phone OFF in health care facilities when regulations posted in the areas instruct you to do so. Hospitals or health care facilities may be using equipment that could be sensitive to external RF energy.

Aircraft

Turn your phone OFF before boarding any aircraft.

- Use it on the ground only with crew permission.
- Do not use in the air.

To prevent possible interference with aircraft systems, U.S. Federal Aviation Administration (FAA) regulations require you to have permission from a crew member to use your phone while the plane is on the ground. To prevent interference with aircraft communication systems, FCC regulations prohibit using your phone while the plane is in the air.

Children

Do not allow children to play with your phone. It is not a toy. Children could hurt themselves or others (by poking themselves or others in the eye with the antenna, for example). Children also could damage the phone or make calls that increase your telephone bill.

Blasting areas

To avoid interfering with blasting operations, turn your unit OFF when in a “blasting area” or in areas posted: “Turn off two-way radio.” Construction crews often use remote control RF devices to set off explosives.

Potentially explosive atmospheres

Turn your phone OFF when in any area with a potentially explosive atmosphere. It is rare, but your phone or its accessories could generate sparks. Sparks in such areas could cause an explosion or fire resulting in bodily injury or even death.

Areas with a potentially explosive atmosphere are often, but not always, clearly marked. They include fueling areas such as gas stations; below deck on boats; fuel or chemical transfer or storage facilities; areas where the air contains chemicals or particles, such as grain, dust, or metal powders; and any other area where you would normally be advised to turn off your vehicle’s engine.





Do not transport or store flammable gas, liquid, or explosives in the compartment of your vehicle which contains your phone or accessories.

In the United States, vehicles using liquefied petroleum gas (such as propane or butane) must comply with the National Fire Protection Standard (NFPA-58). For a copy of this standard, contact the National Fire Protection Association, One Batterymarch Park, Quincy, MA 02269, Attn: Publication Sales Division.

In Canada, vehicles using liquefied petroleum gas (such as propane or butane) must comply with the Canadian Gas Association (CAN/CGS-B149.2). For a copy of this standard, contact the Canadian Standards Association, 178 Rexdale Blvd., Etobicoke, ON M9W 1R3, Attn.: Standard Sales Department.



Table of contents

	Rules and regulations	3	
	Safety precautions	5	
Getting Started	Unpacking your phone	10	Getting Started
	Looking at your phone	12	
	Charging the battery pack	15	
	Turning the phone on	18	
	Using the Jog Dial™ navigator	19	
	Selecting a language	20	
Basic Operations	Making calls	21	Basic Operations
	Receiving calls	23	
Quick Ways to Make Calls	Storing phone numbers in the Phone Book ..	25	Quick Ways to Make Calls
	Calling from the Phone Book	31	
	Searching the Phone Book	33	
	Calling from the Calls List	36	
	Sending DTMF signals from the Phone Book .	38	
Advanced Features	About the Features menu	39	Advanced Features
	Adjusting the volume	41	
	Checking and setting the timers	45	
	Using the Directory	48	
	Miscellaneous extra features	56	
	Setting security options	60	
	Setting display options	66	
	Adjusting network settings	70	
	Using the Short Messaging Service	77	
Additional Information	Troubleshooting	85	Additional Information
	List of menu items	86	
	Specifications	88	
	Glossary	90	
	Index	93	



Unpacking your phone

Carefully unpack your phone and check the contents using this list. If there is something missing, please contact your nearest Sony dealer.

**Portable Dual Band
PCS Telephone (1)**

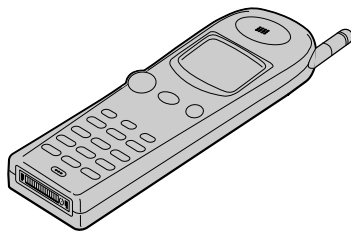

**QN-003BPLH
Hi-Cap Li-Ion
Battery Pack (1)**

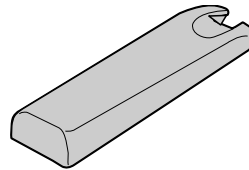

Hand Strap (1)

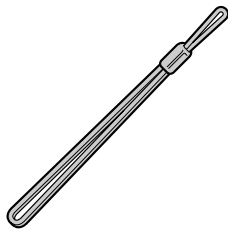

**QN-001AC AC
Adapter (1)**

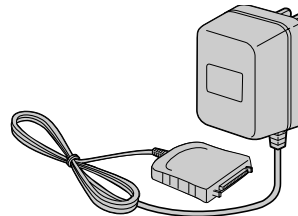



Attaching the hand strap

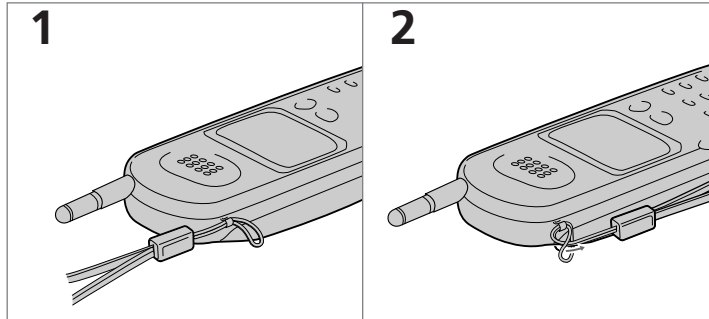

Getting Started



Looking at your phone

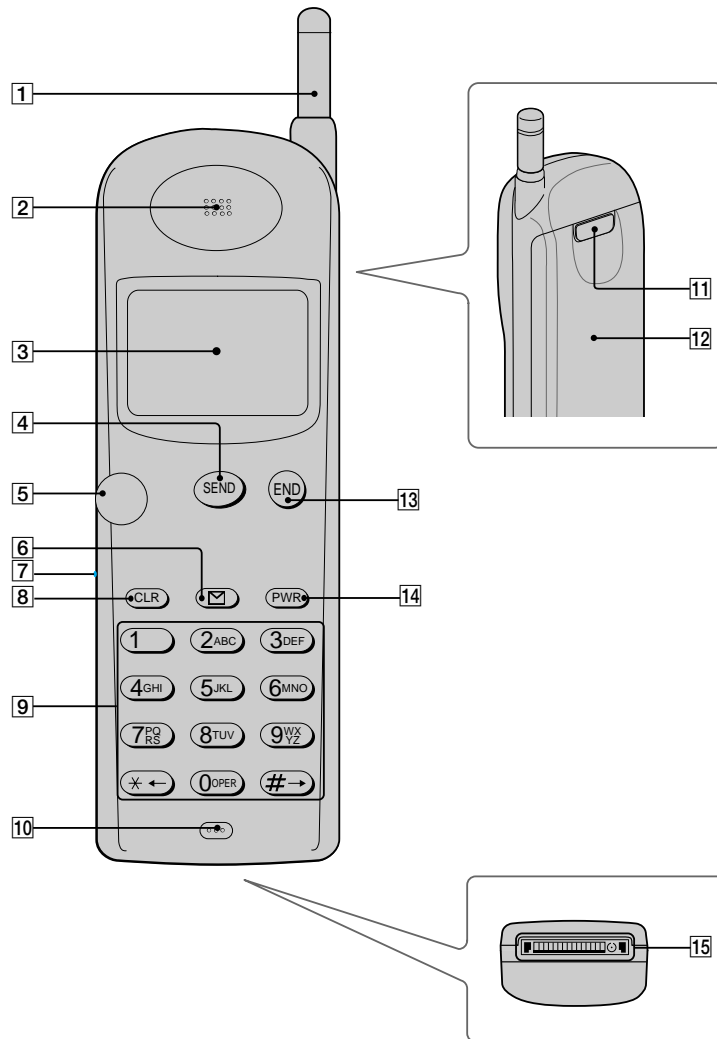

12



For further information, refer to the page numbers indicated in parentheses ().

Telephone

- 1 **Antenna (18)**
- 2 **Earpiece**
- 3 **Display (14)**
- 4 **SEND button (21 to 23)**
Press to make outgoing calls and to receive incoming calls.
- 5 **Jog Dial™ navigator (19)**
Push and turn for menu navigation and for changing settings on menus. In this manual, the  icon indicates that you should push the Jog Dial navigator in towards the center of the phone.
- 6 **MAIL (message) button (78)**
Press to access messages.
- 7 **Ringer speaker**
Small opening that emits the phone's ringer sound.
- 8 **CLR (clear) button (19, 21, 40)**
Press to clear the last or all entered digits on the display, or to exit the current mode of operation.
- 9 **Number buttons, 0 to 9, and *↔/#↔ buttons (21, 25, 32)**
Use the number buttons to enter letters and numbers. Press and hold a number button, 0 to 9, for touch dialing. Use the *↔/#↔ buttons to move the cursor to the right or left when you are entering letters.
- 10 **Microphone**
- 11 **Battery pack release tab (15)**
Slide up to remove the battery pack.
- 12 **Battery pack (15)**
- 13 **END button (19, 21, 23)**
Press to end calls. Also cancels operations and returns the phone to standby mode.
- 14 **PWR (power) button (18)**
Press to turn the phone on or off.
- 15 **Connector (16)**
Use to connect the phone to either the AC adapter, a cigarette lighter adapter, a desktop charger or a hands-free car kit.



Display

The top row of the display contains icons that inform you of the current status of your phone. The bottom four rows of the display are for text such as phone numbers, names and operational prompts. Each row displays a maximum of 12 characters.

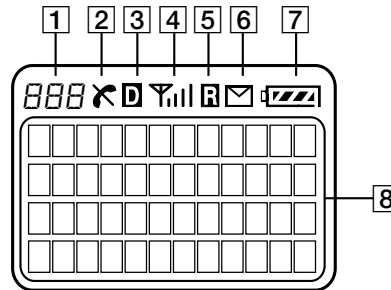

- | | |
|--|---|
| <p>1 Short character display
Shows settings such as the number of the currently displayed Features menu, as well as Phone Book and Calls List memory locations.</p> <p>2 (in-use) / (out-of-service) icon (18, 21, 23, 71)
The in-use icon appears during a call. A slash through the in-use icon appears when no signal is received. You cannot make or receive calls when the out-of-service icon is visible.</p> <p>3 D (digital) icon
Appears when your phone is operating in digital (CDMA) mode.</p> <p>4 Y (signal strength) icon (18)
Indicates the approximate strength of the signal being received.</p> | <p>5 R (roam) icon (71)
Appears when you are roaming outside your home service area.</p> <p>6 M (message) icon (77)
Appears when you have new text or voice mail messages pending. The icon flashes if the new message is urgent.</p> <p>7 B (battery) icon (16, 17)
Shows the approximate amount of charge power remaining in the battery pack. Recharge the battery pack before it is fully discharged.</p> <p>8 Character display
Prompts various actions, and then displays the results. It also shows phone numbers and names.</p> |
|--|---|



Charging the battery pack

Charge the battery before using the phone. A new battery is not fully charged. To charge the battery, attach the battery pack to the handset, then connect the supplied AC adapter.

Getting Started

Attaching the battery pack

- 1 Hook the battery pack onto the bottom of the phone ①, and ease the battery pack down ②.

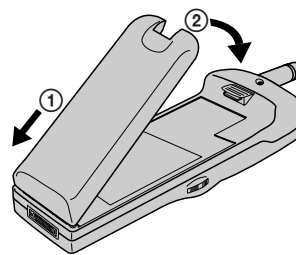

- 2 Attach the battery pack by pressing down firmly on the thumb indent.

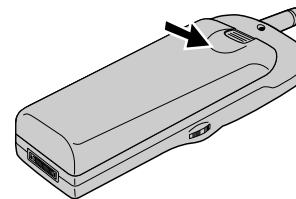

To remove the battery pack

- 1 Push the battery pack release tab upwards.

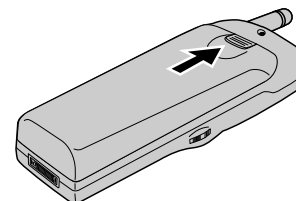

- 2 Lift the top of the battery pack ①, and pull it out ②.

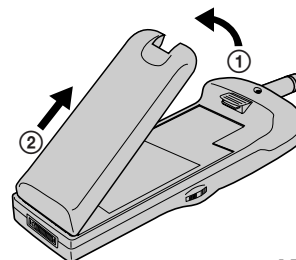

15



Charging the battery

Connect the AC adapter to the phone and the other end to a standard 120V AC outlet as illustrated below. The charging time is about 5 hours. You can charge the battery pack with the phone turned on, but charging will take longer.

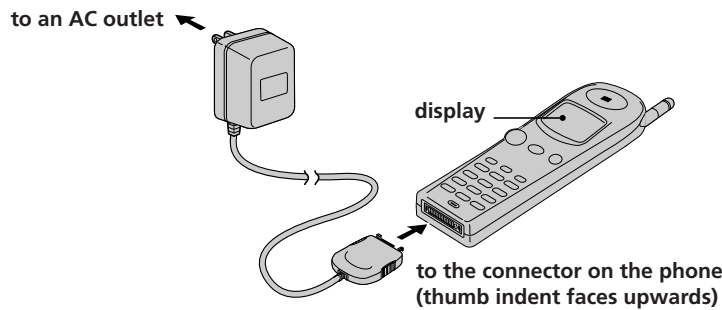

When the power is turned on

The letters “CH” are shown in the upper left corner of the standby display and  flashes. This indicates that the battery pack is being charged.

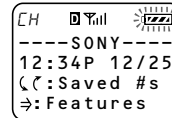

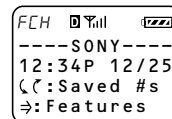

When the battery pack is fully charged, the letters “FCH” appear instead and  stops flashing.

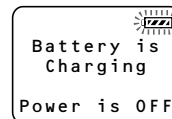

When the power is turned off

The message “Battery is Charging” is displayed and  flashes.



When the battery pack is fully charged, the message “Charging is Complete” is displayed and  stops flashing.

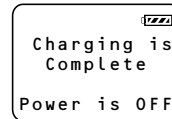

Notes

- If you make or receive a call when the battery pack is not charged sufficiently, the call will be cut off. In that case, you will hear an alarm, indicating that the battery is low.
- You can turn on the phone without the battery pack, but you cannot make or receive a call, even if you connect the AC adapter to an AC outlet.



Notes on charging

- When you charge the battery pack, avoid:
 - charging for long periods of time, since this reduces battery life.
 - charging in temperatures below 32°F (0°C) or over 104°F (40°C).
 - charging the battery in direct sunlight or in places with high humidity (such as a bathroom).
- Do not use any battery pack other than the one specified in these instructions.
- It is normal for the battery pack to become warm during charging or after use.
- The supplied AC adapter is not intended to be serviced. In the event of a malfunction, it should be replaced.

Notes on the battery pack

- Do not dispose of the battery pack in a fire or short-circuit it. Doing so may cause the battery pack to leak or get hot, which could cause personal injury.
- Do not try to disassemble the battery pack.

Checking the battery

Battery duration

	CDMA mode	Analog mode
In standby mode	60 hours	14 hours
In use continuously	4 hours	2 hours

Battery condition

The battery icon indicates the battery level as follows (when the power is on):

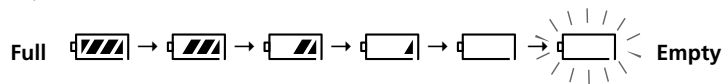

Note that the battery icon displays the approximate charge level and that the consumption may vary depending on conditions of use, such as ambient temperature, network coverage and usage patterns.

When the battery is empty

The battery icon flashes and a warning message is displayed. A beep sounds, indicating that the battery is low. Shortly thereafter, the phone turns off. Recharge the battery as soon as possible.





Turning the phone on

To use your phone, the power must be turned on. It is preferable to extend the antenna, since this maximizes signal strength and minimizes interference.

Pull up 

Extending the antenna

Hold the end of the antenna and pull up until fully extended.

To retract the antenna

Push the antenna down until it is fully retracted.

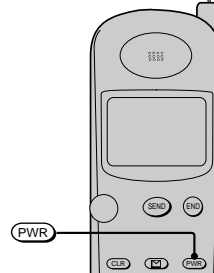

Turning the power on

Hold down **PWR** for about one second. A beep sounds and the phone starts searching for a signal.

When the phone has found a service signal, the standby display appears. Now the phone is ready to use.

To check the signal strength

The signal strength icon indicates various levels of signal strength. It is best to make calls when the signal is strong, although calls can be made when the signal strength is weak.



If you are out of the service area

The out-of-service icon () appears, and the phone searches for a service signal.

If a signal cannot be found, the phone enters power save mode. It will "wake up" automatically at intervals (based on carrier network settings) to search for a service signal.



Turning the power off

Hold down **PWR** for about one second. The following display appears briefly, then the phone turns off.

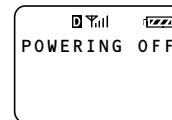



Using the Jog Dial™ navigator

The Jog Dial™ navigator makes it easy to navigate from one menu to another. Simply turn the Jog Dial up (↶) or down (↷) to view the list of menus and submenus. When the flashing arrow (⇒) points to the menu item you want to select, press the Jog Dial in toward the phone.

Getting Started

Choosing a menu item

Operation	Illustration	Function
Turn		<ul style="list-style-type: none">• Scrolls through the current menu, Phone Book or Calls List.
Push		<ul style="list-style-type: none">• Selects the item indicated by the flashing arrow (⇒).• Accepts the digits/characters entered using the keypad.
Push and Hold (for more than one second)		<ul style="list-style-type: none">• Locks the keypad.• Mutes/unmutes the phone.

To go back

If you want to go back to the previous display, press **CLR**. If you want to return to the standby display, either press **END** or hold down **CLR**.

Scrolling through menu items

To scroll through menu items, turn the Jog Dial navigator when the ↶ icon appears. The up (↶) and down (↷) arrows on the display indicate the available scrollable direction.





Selecting a language

Your phone has three interface languages available: English, French and Spanish. To view the menus in French or Spanish, change the menu language as shown below.

1 On the standby display, turn to select "Display", then push .



2 Turn to select "Language", then push .

The Language menu appears. The current setting is indicated by a check mark (✓) and is displayed in capital letters.

3 Turn to select "French" or "Spanish".

4 Push to enter the new setting.

The standby display reappears in the language selected.

Alphanumeric table

Each time you press a number button, the letters/numbers are cycled as shown on the following table.

Button	English Sequence
	- → " → . → ' → , → & → (→) → : → 1
	A → B → C → a → b → c → 2
	D → E → F → d → e → f → 3
	G → H → I → g → h → i → 4
	J → K → L → j → k → l → 5
	M → N → O → m → n → o → 6
	P → Q → R → S → p → q → r → s → 7
	T → U → V → t → u → v → 8
	W → X → Y → Z → w → x → y → z → 9
	0

Note

Each language has its own alphanumeric table. To view another language table, refer to the respective phone operating instructions. Not all areas distribute the phone operating instructions in all languages. To obtain operating instructions in another language, contact Sony Customer Service.



Making calls

You can call any number up to 32 digits from within a service area. The out-of-service icon (✕) indicates that you are outside the service area.

In the following example, the phone number to be called is 123-456-7890.

1 Use the number buttons to enter the number.

If you enter the wrong digit, press **CLR** to back up. To clear all entered digits, press **END** or hold down **CLR** to return to the standby display.

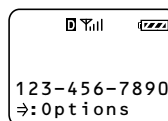

Basic Operations

2 Press **SEND** to dial.

The phone dials the number you have entered. The  icon appears. When the call is connected, the call timer appears and displays the elapsed call time.

3 Press **END** to end the call when you are finished.

The  icon disappears and the final elapsed call time flashes for 10 seconds. The standby display automatically reappears.

Tips

- When dialing, you can insert a pause to attach a DTMF (Dual Tone Multiple Frequency) number to the number you are calling (see page 38 for a description of DTMF).
- If Auto-Hyphen is turned on, the phone number is hyphenated automatically as you enter the digits (see page 68).
- If Minute Alert is turned on, a beep sounds 10 seconds before every full minute throughout the call (see page 46).
- Enhanced voice privacy is indicated by the message “-P-” displayed in the upper left corner of the LCD (see page 73). This feature is carrier-dependent.



To adjust the earpiece volume during a call

Turn  up to increase the volume.

Turn  down to decrease the volume.

Tip

You can also adjust the volume using the Sounds menu (see page 43).

To mute/unmute the microphone during a call

Push and hold .

Tip

You can also mute the microphone using the Sounds menu (see page 42).

To redial the last number

On the standby display, press . The number you dialed last is redialed automatically.





Receiving calls

You can receive calls as long as the out-of-service icon (🚫) is not displayed. The 🚫 icon indicates that you are outside the service area.

When you receive a call, the ringer sounds and “Incoming Call” flashes.

Notes

- If you turn off the ringer volume (see page 41), you will not hear the ringer sound. The message “-Ringer Off-” is displayed on the standby display.
- You can quickly mute the ringer when you receive a call by turning 📞 down (see page 41).

1 Press **SEND** to answer the call.

When the call is connected, the call timer appears and displays the elapsed call time.

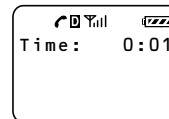

Basic
Operations

2 Press **END** to end the call when you are finished.

The 📞 icon disappears and the final elapsed call time flashes for 10 seconds. The standby display automatically reappears.

Tips

- Using the Jog Dial navigator, you can adjust the earpiece volume or mute the microphone during a call (see page 22).
- Enhanced voice privacy is indicated by the message “-P-” displayed in the upper left corner of the LCD (see page 73). This feature is carrier-dependent.
- If AnyKey Answ is turned on, you can answer the call by pressing any button except **PWR** (see page 58).



If the caller supports caller ID

The caller's phone number appears on the display when you receive a call, if both the caller and the carrier support this feature.

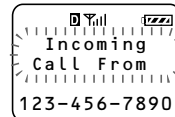

If the caller supports caller ID and the number matches a Phone Book entry, the name that you stored with the number (if any) is displayed also.

Note

When you receive a call waiting alert, the phone number of the caller is displayed if caller ID is supported (similar to a normal incoming call). If the phone number matches a Phone Book entry, the name is also displayed.

If you miss a call

If you miss an incoming call, a notification message appears accompanied by an audible alert. To return to the standby display, either press **CLR**, **END** or . If the caller supported caller ID, the caller's number is stored in the Calls List (see page 36).

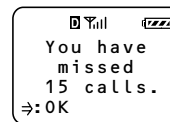



Storing phone numbers in the Phone Book

Your phone features a built-in Phone Book memory, in which you can store up to 99 (01-99) phone numbers with names. You can dial stored numbers quickly by recalling them from the Phone Book (see page 31).

Each phone number can contain up to 32 digits, and each name up to 12 characters. This section shows how to store, edit and erase Phone Book numbers quickly.

In the following example, the phone number to be stored is 123-456-7890 and the name is SONY.

1 On the standby display, use the number buttons to enter the number.

The number appears on the display.

You can also store hyphens, pauses and links with your Phone Book entries (see page 27).

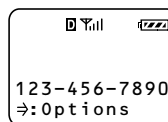





2 Push .

The Options menu appears.

3 Turn to select "Save", then push .

A display appears prompting you for a name to accompany the number.

4 Use the number buttons to enter the name.

If you press the same button in quick succession, the letter you just entered changes. (See the "Alphanumeric table" on page 20.) For the next entry, wait until the cursor moves one step to the right or use  or  or  to move the cursor and insert spaces between characters. If you enter the wrong character, press  to clear the character highlighted by the cursor.

To enter "SONY"

Press  four times to enter an "S".

Press  three times to enter an "O". Wait until the cursor moves one step to the right for the next entry.

Press  twice to enter an "N".

Press  three times to enter a "Y".



Quick Ways
to Make Calls



5 When you are finished, push to store the phone number and name.

A message appears indicating the first available memory location.

6 Push to store the new number in the first available memory location.

If you want to store it in another location, turn  to select the desired location or enter the location number, then push . A confirmation message appears followed by the status of the Phone Book.

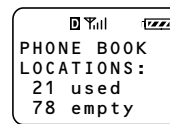

Tip

You can also use the Directory menu to store Phone Book numbers (see page 48).

If the Phone Book is full

A message appears if no memory locations are available. After entering a name, a display appears prompting you to specify a memory slot to overwrite. To cancel, hold down .

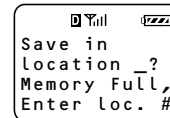



To enter a hyphen, pause or link

In addition to digits, you can insert hyphens, pauses and links into the phone number of a Phone Book entry.

Hyphens: Turn off the phone's autohyphenation feature (see page 68) when you want to enter a hyphen manually, e.g., when you store a foreign number.

Pauses: When you want to send DTMF signals (see page 38) for electronic banking, etc., inserting a pause after the first string of digits causes the phone to pause before dialing the second string. This ensures your counterpart is ready to accept the second string. A Time Pause waits for a specified period of time before sending the second string. A Hard Pause requires the pause to be manually released before sending the second string.

Links: You can join two or more Phone Book entries (e.g., a doctor's phone number and your medical record number). Once you have specified the first entry, you insert a link. Then specify the second number by entering its memory location number.

Quick Ways
to Make Calls



1 While entering digits, push .

The Options menu appears.

2 Turn to select the information you want to enter, then push .

After inserting a hyphen, pause or link, the display returns to number entry mode.

To enter	Select	The display shows
a hyphen	Enter Hyphen	-
a pause	Enter Time Pause or Enter Hard Pause	T H
a link	Enter Link	L





Editing stored information

You can edit the name, phone number and memory location of specific entries stored in the Phone Book.

- 1 On the standby display, turn  once.**

The Saved #s display appears.

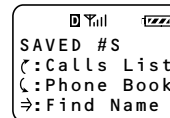

- 2 Turn  down to select "Phone Book".**

The first entry in the Phone Book appears.

- 3 Turn  to select the entry that contains the information you want to edit.**

The contents of the selected memory location are displayed.

- 4 Push .**

The Options menu appears.

- 5 Turn  to select "Edit", then push .**

The Edit menu appears.

- 6 Turn  to select the item you want to edit, then push .**



The stored information that corresponds to the selected item appears.

- 7 Enter the new information.**

Enter new information the same way you stored original information (see page 25). The old information is overwritten.

- 8 When you are finished, push .**

The Options menu reappears when you edit the phone number. New information is saved immediately when you edit the name or memory location.

- 9 Turn  to select "Save", then push .**

A message appears confirming that your changes have been saved.

Tip

You can also use the Directory menu to edit Phone Book numbers (see page 51).

28





Erasing a phone number

You can erase stored Phone Book entries. If the selected entry is restricted, you must enter the four-digit lock code before you can erase it (see page 60).

1 On the standby display, turn  down twice to select "Phone Book".

The first Phone Book entry is displayed.

2 Turn  to find the Phone Book entry you want to erase.

The contents of the selected memory location are displayed.

3 Push .

The Options menu appears.

4 Turn  to select "Erase", then push .

A message appears prompting you to confirm the erasure.

5 Push  again.

The selected entry is erased. After a few seconds, the standby display reappears.

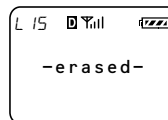

Quick Ways
to Make Calls

Tips

- You can also use the Directory menu to erase one Phone Book entry at a time (see page 50).
- Use the Security menu to erase all Phone Book entries at once (see page 64).





Restricting Phone Book entries

You can restrict individual Phone Book entries or the entire Phone Book, so that access can be gained only by entering a lock code (see page 62,63). The phone numbers of restricted entries will not be displayed.

- 1 Select the Phone Book entry you want to restrict, then push .**

The Options menu appears.



- 2 Turn  to select "Restrict", then push .**

- 3 Push  to restrict the selected entry.**

Now the selected entry is restricted.
After a few seconds the standby display reappears.

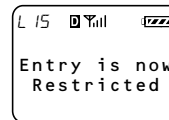

To unrestrict an entry

- 1 Select the Phone Book entry that you want to unrestrict.**

The display indicates the entry is restricted.

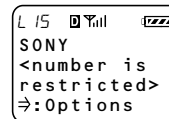

- 2 Push .**

The Options menu appears.

- 3 Turn  to select "Restrict", then push .**

A message appears prompting you to enter the lock code.

- 4 Use the number buttons to enter the lock code.**

Now the selected entry is unrestricted.
After a few seconds the standby display reappears.

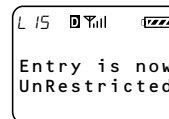

Tip

You can also use the Security menu to restrict/unrestrict Phone Book entries (see page 62).





Calling from the Phone Book

You can dial frequently used numbers quickly from the Phone Book using the Jog Dial navigator. Alternatively, by using speed dialing or touch dialing, you only need to press a few buttons to dial these numbers.

1 On the standby display, turn once.

The Saved #s display appears.

2 Turn down to select "Phone Book".

The first entry in the Phone Book appears.

3 Turn to select the desired Phone Book entry.

The contents of the selected entry are displayed.

4 Push .

The Options menu appears.

5 Push again to make a call.

The phone dials the number stored in the selected Phone Book entry. The  icon appears.

Quick Ways
to Make Calls

Tips

- You can search for a phone number by name or memory location (see pages 33 and 34).
- Whenever the phone number is displayed, you can call it by pushing .
- If the phone number of a selected Phone Book entry is too long to fit on the screen, you can still view the overflow digits by selecting "View Number" on the Options menu.

To release a pause or link during a call

If a Phone Book entry contains pauses or links, only the digits up to the first Hard Pause or link are displayed. To dial the rest of the selected entry (and release the Hard Pause or link), push .

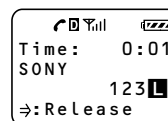



Speed dialing

To dial quickly, you can enter the Phone Book memory location numbers. The phone calls the number stored in the corresponding location.

1 Use the number buttons to enter the memory location number.

2 Press  to dial the number.

The name and phone number of the memory location appear. The phone dials the number stored in the entered memory location.

Touch dialing

You can dial a phone number stored in the Phone Book without pressing .

Before using this feature, make sure that Touch Dial on the Extras menu is set to “on” (see page 57).

1 Use the number buttons to enter the memory location number, and hold down the last digit of the memory location number for about two seconds.

The name and phone number of the memory location appear. The phone dials the number stored in the entered memory location.





Searching the Phone Book

To locate a desired Phone Book entry, you can search by name, phone number or memory location. You can search the Phone Book either alphabetically or for a string of characters.

Searching alphabetically

When you enter only one character, the phone lists all entries that begin with the entered character.

1 From the standby display, turn



once.

The Saved #s display appears.

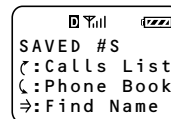

2 Push



The Search display appears.

3 Enter only the first letter of the name you want to find.

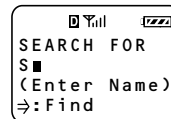

Quick Ways to Make Calls



4 Push



All Phone Book entries that begin with the entered character are displayed alphabetically.

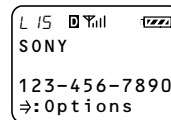

5 Turn to view the next entry.

Tip

You can also use the Directory menu to search the Phone Book by name (see page 52).



Searching for a string of characters

When you enter two or more characters, the phone searches for entries that contain those characters. The results are displayed starting from the lowest memory location number.

- 1 From the standby display, turn  once.**

The Saved #s display appears.

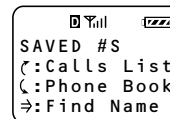

- 2 Push .**

The Search display appears.

- 3 Enter at least two characters.**

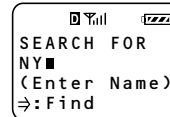

- 4 Push .**

The entries containing the selected string are displayed starting from the lowest memory location number.

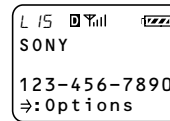

- 5 Turn  to view the next entry that contains the search string.**

Searching by memory location

The phone searches for a memory location that matches the entered digit(s), and displays a list of options.

- 1 On the standby display, enter the memory location (a maximum of two digits).**

- 2 Push .**

The Options menu appears.





3 Turn up to select "Recall Loc#", then push .

The Phone Book entry stored in the selected memory location is displayed.

If the entered location is empty, a message appears. After a few seconds, the standby display reappears.

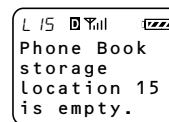

Tip

You can also use the Directory menu to search the Phone Book by memory location (see page 54).

Searching for a phone number

The phone lists all entries that contain the entered digit(s).

1 On the standby display, enter at least the first three digits of the phone number you want to find.

2 Push .

The Options menu appears.

3 Turn up to select "Find Number", then push .

The Phone Book lists and displays all entries matching the entered digits. Depending on the Sort Book setting (see page 68), the entries are listed either alphabetically or by memory location.

4 Turn up to view the next entry that contains the search string.

If a matching Phone Book entry is not found, a message is displayed. After a few seconds, the standby display reappears.

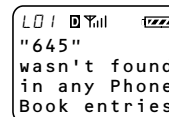

Quick Ways
to Make Calls





Calling from the Calls List

Information on the ten most recent outgoing calls, incoming calls, scratch pad entries and missed calls are stored in the phone's Calls List. If you call the same number twice in a row, only the most recent call is stored in the Calls List.

1 On the standby display, turn  once.

The Saved #s display appears.

2 Turn  up to select "Calls List".

Information on the most recent call appears. "Calls List is empty" is displayed if there are no entries.

3 Turn  to select the entry you want.

The contents of the selected entry are displayed.

4 Push .

The Options menu appears.

5 Push  again to call the selected entry.

The phone dials the selected Calls List entry. The  icon appears.

Tips

- You can also dial by pressing  after selecting the entry in step 3 on page 35.
- If the selected entry contains a pause or a link, only the digits up to the pause or link are dialed. To release pauses and links, see page 31.
- You can also use the Directory menu to view the Calls List (see page 55).





To view detailed information of Calls List entries

You can also view the digits of a phone number that do not fit on the screen, the duration of the call or the time and date of the call by using the Options menu (see step 4 on page 36).

To view	Select
digits that do not fit on the screen	View Number
the duration of the call	Duration
the time and date of the call	Time/Date

To save the number to the Phone Book

Select "Save" from the Options menu (step 4 on page 36) by pushing the Jog Dial navigator.

Quick Ways
to Make Calls



Sending DTMF signals from the Phone Book

You can send DTMF (Dual Tone Multiple Frequency) signals to access electronic services (such as telephone banking) when dialing numbers from the Phone Book. Dual Tone Multiple Frequency is also known as “touch-tone”. A tone is generated when you press a telephone button (number, * or #). It can be used to access answering machines, pagers, telephone banking services, data services and other electronic services.

1 During a call, search for the Phone Book entry that contains the numbers you want to send.

The selected entry is displayed. Use the Directory menu to search for the Phone Book entry (see pages 52 to 54).

2 Push .



The Options menu appears.

3 Turn to select “Number Tone”, then push .

A DTMF signal containing the entered digits, is sent in a burst.

DTMF signal in standby mode

You can send a DTMF signal only during a call. If you try to send a DTMF signal in standby mode, the following message is displayed.

LD 1   
Tones can
be played
only during
a call.

Notes

- To enter and send numbers one by one during a call, use the number buttons to send the DTMF number.
- To change the length of the DTMF transmission, see “Setting the keybeep length” on page 44.



About the Features menus

You can use the Features menus to activate the special features of your phone (e.g., backlighting or display).

Menu structure

The phone uses a hierarchical on-screen menu structure for setting and editing parameters. For a comprehensive list of submenus and corresponding settings, see “List of menu items” on pages 86 and 87.

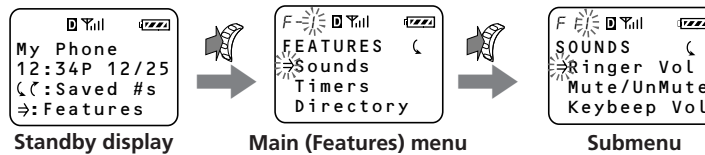

Viewing and selecting menu options

The Jog Dial navigator makes it easy to navigate the phone's menus. The procedure to view and select menu options is common to most of the Features menus (see page 86). These menus are also accessible during a call. The following example shows how to set the backlight.

1 On the standby display, push to select “Features”.

If the standby display is not shown, press **END** or hold down **CLR**, then push to display the Features menu. The arrow and the menu number flash, indicating which menu will be selected by pushing (in this case the Sounds menu [F-1]).



Advanced Features

2 Turn to select “Display”, then push .

The Display menu appears. The arrow and the last digit of the submenu number flash, indicating which submenu will be selected by pushing (in this case the Banner menu [F61]).





3 Turn to select "Backlight", then push .

The Backlight menu appears. The current setting is indicated by a check mark (✓) and is displayed in capital letters. (See page 67 for an additional description on setting the backlight.)

4 Turn to select the setting.

The available options appear in a cyclic manner as you turn .

5 Push to enter the new setting.

The standby display reappears.



To exit from the Features menu

Press **END** or hold down **CLR** to return to the standby display.



To return to the previous display

Press **CLR**. To go back further, press **CLR** again.

Notes

- If you reach the last menu item and try to turn  further, a beep indicates that you have reached the end of the menu. To view other menu items, turn  in the opposite direction.
- The standby display automatically reappears after 30 seconds of inactivity.

Tip

Each menu item can be accessed quickly from the standby display by pushing  and then pushing the number of the menu item. The item number then appears in the upper left corner of the display in step 3. For example, you can access the backlight setting by pushing  followed by **6** and **2**.





Adjusting the volume

You can adjust the volume of the ringer, keybeep and earpiece on the Sounds menu. You can also select the type of sounds heard when the phone rings and when you press buttons. (See page 39 for instructions on how to reach the Sounds menu.)



Sounds menu

Adjusting the ringer volume [F11]

1 Push to select "Ringer Vol." from the Sounds menu.

The Ringer Vol. menu appears.

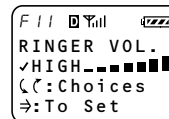

2 Turn up to raise the ringer volume, and down to lower it.

You can select from five ringer volume settings: "off", "low", "med." (medium), "high" and "escalate".

3 Push to enter the new setting.

The standby display reappears.

If you turn off the ringer volume

The message "-Ringer Off-" is displayed at the top of the screen when the standby display appears.

Tip

If you set the ringer volume to "escalate", the telephone rings twice at a low volume, then once at medium volume and thereafter at a high volume.

To mute the ringer

When you are unable to take a call (e.g., during a meeting) turn down to quickly mute the ringer. The unanswered call will be stored in the Calls List.

Notes

- Only the current call is muted; turn down to mute each additional call.
- To adjust the ringer volume without muting the ringer, turn up to activate the ringer adjustment, then turn as desired.
- To mute the microphone during a call push and hold (see page 22).

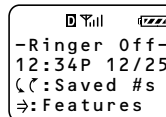

Advanced Features





Muting/unmuting the microphone [F12]

You can mute/unmute the phone during a call directly, without using the Sounds menu, by pushing and holding . You can also mute/unmute the microphone during a call using the Sounds menu. This feature is disabled in standby mode.

- 1 During a call, push to select "Sounds" from the Features menu.

The Sounds menu appears.

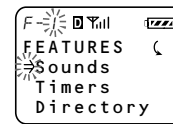

- 2 Push to select "Mute/UnMute".

The following display appears. Now the microphone is muted.

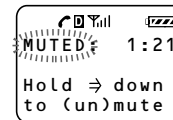

- 3 To unmute the microphone, push and hold for one second.

The Features menu appears for a moment and the microphone is now unmuted.



Adjusting the keybeep volume [F13]

You can adjust the volume of the beep that sounds when you press a button.

- 1 Turn to select "Keybeep Vol" from the Sounds menu, then push .

The Keybeep Vol menu appears.

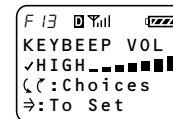

- 2 Turn up to raise the keybeep volume, and down to lower it.

You can select from four keybeep volume settings: "off", "low", "med." (medium) and "high".

- 3 Push to enter the new setting.

The standby display reappears.

42





Adjusting the earpiece volume [F14]

You can adjust the earpiece volume during a call by turning . You can also adjust the speaker volume using the Sounds menu.

- 1 Turn to select "Earpiece Vol" from the Sounds menu, then push .

The Earpiece Vol menu appears.

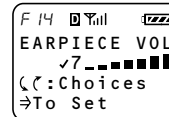

- 2 Turn up to raise the earpiece volume, and down to lower it.

You can select from seven earpiece volume settings, from "1" to "7". A higher number indicates higher volume.

- 3 Push to enter the new setting.

The standby display reappears.



Setting the ringer type [F15]

You can set the type of beep that sounds for an incoming call.

- 1 Turn to select "Ringer Type" from the Sounds menu, then push .

The Ringer Type menu appears.

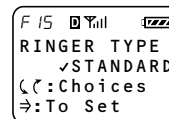

- 2 Turn to select the ringer type.

You can select from five different ringer settings. The ringer sounds every time you turn .

- 3 Push to enter the new setting.

The standby display reappears.

Advanced Features





Setting the keybeep type [F16]

You can set the beep that sounds when you press a button to either a tone or a click. Tones sound similar to DTMF tones and clicks are indicated by single beeps.

- 1 Turn to select “Key Sound” from the Sounds menu, then push .

The Key Sound menu appears.

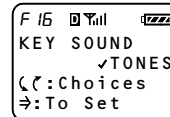

- 2 Turn to select the keybeep type.

You can select “tones” or “clicks”.

- 3 Push to enter the new setting.

The standby display reappears.

Note

DTMF tones are sent to the other party during a call even if you set the keybeep type to “clicks”.

Setting the keybeep length [F17]

You can set the length of the beep that sounds when you press a button. This setting affects both the keybeep feedback and DTMF transmission tones. The phone sends a short DTMF burst (default) or plays every tone of the DTMF signal as long as the key is held down.

- 1 Turn to select “Beep Length” from the Sounds menu, then push .

The Beep Length menu appears.

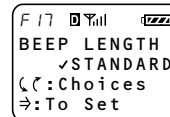

- 2 Turn to select the keybeep length.

You can select “standard” or “long”.

- 3 Push to enter the new setting.

The standby display reappears.

44





Checking and setting the timers

You can check call durations on the Timers menu. You can also set the phone to alert you every minute of a call and make the phone turn itself off automatically.

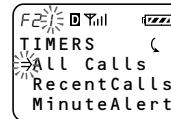

Timers menu

Checking the duration of all calls [F21]

You can view the total duration of all calls. This information cannot be reset.

- 1 Turn to select "All Calls" from the Timers menu, then push .

The All Calls display appears.

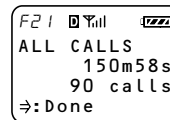

- 2 Push to go back to the standby display.



Checking and resetting the duration of recent calls [F22]

You can view the total duration of the most recent calls.

- 1 Turn to select "Recent Calls" from the Timers menu, then push .

The Recent Calls display appears.

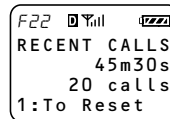

Advanced Features

- 2 Press to reset, or hold down to go back to the standby display.

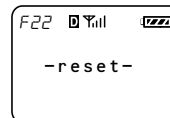

If you choose to reset, the counter of recent calls and the corresponding durations are reset.







Setting the minute alert [F23]

You can set the phone to alert you ten seconds before every full minute.

- 1 Turn  to select "Minute Alert" from the Timers menu, then push .

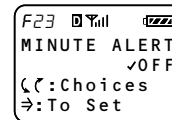
The Minute Alert menu appears.





- 2 Turn  to select "on" or "off".
- 3 Push  to enter the new setting.
The standby display reappears.







Setting the phone to automatically turn off [F24]

You can set the phone to automatically turn itself off after a specified duration.

- 1 Turn  to select "Auto-Off" from the Timers menu, then push .

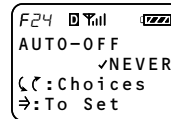
The Auto-Off menu appears.



- 2 Turn  to select the duration before the phone powers off automatically.

You can select from five settings: "never", "in 3 hours", "in 2 hours", "in 1 hour" and "in 30 mins". If you select "never", the phone does not turn itself off automatically.

- 3 Push  to enter the new setting.

If you set the phone to power off in 30 minutes, for example, the following display appears.

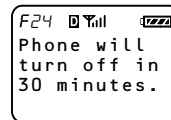

Notes

- If you press any button or operate the Jog Dial navigator, the timer is reset and the countdown starts over.
- The phone does not turn itself off automatically during a call.
- If the Auto-Off timer is set, the phone turns off after a user-specified duration and the countdown "Off:xx:xx:xx" is displayed.
- Once the phone turns off, the setting will revert to "never".

Advanced Features



Using the Directory

You can use the Directory menu to check your phone number, as well as store, erase and edit phone numbers and names in the Phone Book. You can also use this menu to view the Calls List.

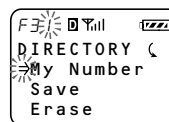

Directory menu

Checking your phone number [F31]

- 1 Push to select "My Number" from the Directory menu.

The My Phone # display appears, showing your phone's number.

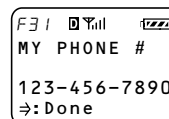

- 2 Push to exit this feature.

The standby display reappears.

Storing phone numbers [F32]

For quick and easy dialing, the Phone Book allows you to store up to 99 phone numbers.

- 1 Turn to select "Save" from the Directory menu, then push .

The following display appears.

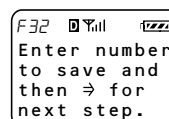

- 2 Use the number buttons to enter the phone number, then push .

The Options menu appears. (See the "Alphanumeric table" on page 20.)

- 3 Turn to select "Save", then push .

A display appears prompting you for a name to accompany the number.





4 Use the number buttons to enter the name.

Use ***** or **#** to move the cursor or to insert spaces between characters. If you enter the wrong character, press **CLR** to clear the character highlighted by the cursor. (See the “Alphanumeric table” on page 20.)

5 When you are finished, push to store the phone number and name.

A confirmation message appears.

6 Push to store the new number in the first available memory location.

If you want to store it in another location, turn  to select the desired location, then push . A confirmation message appears, followed by the status of the Phone Book.

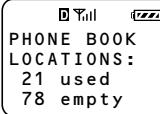

```
☐ 111 ☐ 1111
PHONE BOOK
LOCATIONS:
21 used
78 empty
```

Tip

You can also use the Options menu to store Phone Book numbers (see page 25).



Erasing a phone number [F33]

You can erase stored Phone Book entries. If the selected entry is restricted, you must enter the four-digit lock code to erase it (see page 60).

1 Turn to select "Erase" from the Directory menu, then push .

The following display appears, prompting you for the Phone Book entry to be erased.

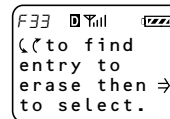

2 Turn to select the entry you want to erase, then push .

A message appears prompting you to confirm that the selected Phone Book entry should be erased. You can also use the number buttons to select the entry to be erased.

3 Push again.

The selected entry is erased. After a few seconds, the standby display reappears.

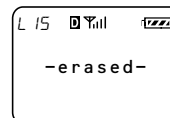

Tips

- You can also use the Options menu to erase one Phone Book entry at a time (see page 29).
- Use the Security menu to erase all Phone Book entries at once (see page 64).





Editing stored information [F34]

You can edit the name, phone number and memory location of specific entries stored in the Phone Book. If the selected entry is restricted, you must enter the four-digit lock code to edit it (see page 60).

- 1 Turn to select "Edit" from the Directory menu, then push .

The following display appears, prompting you for the Phone Book entry to be edited.

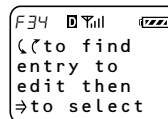

- 2 Turn to select the entry that contains the information you want to edit.

You can also use the number buttons to select the entry to be edited. A message appears prompting you to confirm that the selected Phone Book entry should be edited.

- 3 Push again.

The Edit menu appears.

- 4 Turn to select the item you want to change, then push .

You can change the name, phone number or memory location by selecting "Name", "Phone #" or "Location #" respectively. The stored information that corresponds to the selected item appears.

- 5 Enter the new information.

The old information is overwritten.

- 6 When you are finished, push .

A display appears confirming that your changes have been saved.

Tip

You can also use the Options menu to edit Phone Book entries (see page 28).





Searching the Phone Book by name [F35]

You can find name entries in the Phone Book by searching alphabetically or for a string of characters.

Tip

You can also use the Options menu to search the Phone Book by names (see pages 33 and 34).

To search alphabetically

When you enter only one character, the phone lists all entries that begin with the entered character.

1 Turn to select "Find Name" from the Directory menu, then push .

The Search display appears, prompting you for a search string.

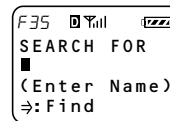

2 Enter only the first letter of the name you want to find.

3 Push .



All Phone Book entries that begin with the entered character are displayed alphabetically.

4 Turn to view the next entry.



To search for a string of characters

When you enter two or more characters, the phone searches for entries that contain the entered string. The results are displayed starting from the lowest memory location number.

1 Turn  to select "Find Name" from the Directory menu, then push .

The Search display appears, prompting you for a search string.

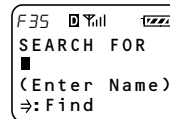

2 Enter at least two characters.

3 Push .

The entries containing the selected string are displayed starting from the lowest memory location number.

4 Turn  to view the next entry.



Advanced
Features





Searching the Phone Book by memory location [F36]

1 Turn to select "Phone Book" from the Directory menu, then push .

A display appears prompting you for a search string.

2 Use the number buttons to enter the memory location number.

The Phone Book entry that matches the search string is displayed. If the selected entry is empty, the display shows the message "Phone Book storage location XX is empty". After a few seconds, the standby display reappears.

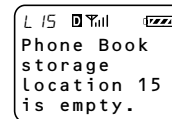

Tips

- You can also use the Options menu to find Phone Book memory locations (see page 34).
- You can also turn  to scroll through the entire Phone Book instead of entering the memory location number in step 2.





Viewing the Calls List [F37]

You can view Calls List entries easily.

1 Turn to select "Calls List" from the Directory menu, then push .

The following display appears, allowing you to view the Calls List. If the Calls List is empty, the display shows the message "Calls List is empty".

F37
Call for calls
List. Then →
to get each
call's time

2 Turn to view the Calls List entries.

The most recent entry is displayed first. To view the rest of the ten most recent entries, turn .

Tip

You can also view the Calls List from the standby display (see page 36).

To place a call

Press in step 2. You can also push to go to the Options menu, then select "Send" and push .

06
Calling...
SONY
123-456-7890

Advanced
Features



Miscellaneous extra features

On the Extras menu, you can set the phone to enable touch dialing, redial automatically and answer incoming calls automatically or at the press of any button. You can also use this menu to lock the keypad and to jot down phone numbers.



Extras menu

Preventing accidental operation [F41]

You can lock the keypad from the standby display or using the phone's menus. Locking the keypad offers low-level security. For example, it disables accidental dialing when you keep the phone in your pocket. Keyguard will remain active until the keypad is manually unlocked.

- 1 From the standby display push and hold .
or
From the Extras menu turn to select "Keyguard", then push .

The following message appears.

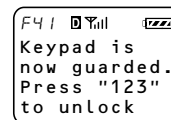

After a few seconds, the standby display reappears. The keypad lock icon () and the text "Keyguard On" indicates that the keypad is locked.



To unlock the keypad

To turn the Keyguard off, press , and in quick succession.

To answer an incoming call when the keypad is locked

Just press . You do not need to unlock the keypad. When the call is ended, the phone automatically reverts to Keyguard On.

Tips

- You can lock the keypad even when the phone itself is locked (see page 60).
- The keybeeps are turned off when the keypad is locked.
- To activate the backlight while Keyguard is on, press and hold .



Activating touch dialing [F42]

If you want to use the touch dialing feature (see page 32), set to “on”.

- 1 Turn to select “Touch Dial” from the Extras menu, then push .

The Touch Dial menu appears.

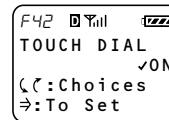

- 2 Turn to select “on” or “off”.

- 3 Push to enter the new setting.

The standby display reappears.

Setting the phone to redial automatically [F43]

You can set the interval for redialing. If the attempt to dial is unsuccessful, the phone tries to redial it up to five times.

- 1 Turn to select “Auto-Retry” from the Extras menu, then push .

The Auto-Retry menu appears.

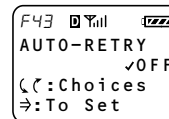

- 2 Turn to select the interval setting.

You can select “off”, “on 60 secs”, “on 30 secs” or “on 10 secs”. If you select “off”, the phone does not try to redial automatically.

- 3 Push to enter the new setting.

The standby display reappears.

Advanced Features



Setting the phone to answer automatically [F44]

You can set the phone to answer calls automatically. If you turn auto-answering on, the phone answers incoming calls on the second ring when the phone is used in conjunction with a Sony Hands-Free Car Kit.

- 1 Turn to select "Auto-Answer" from the Extras menu, then push .

The Auto-Answer menu appears.

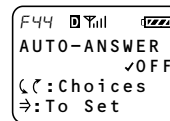

- 2 Turn to select "on" or "off".

- 3 Push to enter the new setting.

The standby display reappears.

The message "-AutoAnswer-" is displayed on the standby display only when you select "on" and the phone is in the hands-free car kit.



Setting all buttons to answer incoming calls [F45]

You can have all buttons (except) answer incoming calls by turning this feature on.

- 1 Turn to select "Any Key Answ" from the Extras menu, then push .

The Any Key Answ menu appears.

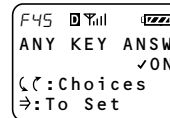

- 2 Turn to select "on" or "off".

- 3 Push to enter the new setting.

The standby display reappears.





Using the scratch pad [F46]

Your phone has a scratch pad feature, which is useful for writing down phone numbers temporarily. The phone does not send DTMF tones when you enter digits to the scratch pad.

1 Turn to select "Scratch Pad" from the Extras menu, then push .

The Scratch Pad display appears, prompting you to enter a phone number.

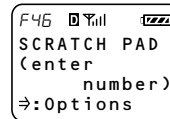

2 Use the number buttons to enter the digits.

3 Push .

The Options menu appears. Besides storing digits, you can enter hyphens, pauses and links (see page 27).

4 Turn to select "Store&Exit", then push .

The information is stored as a scratch pad entry in the Calls List. When the Calls List reaches more than 10 list items, the oldest entries will be deleted as needed to make room for new entries.

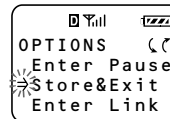

Advanced Features



Setting security options

You can restrict unauthorized access to your phone and the information it holds. In addition, on the Security menu, you can reset menu settings to default and store emergency numbers. Unlike other items on the Features menu, accessing the Security menu requires a lock code when you select it from the Features menu.

A typical default lock code is either the last four digits of your phone number or 0000.

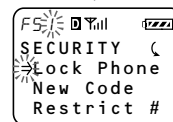
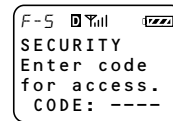

Security menu

Preventing others from using your phone [F51]

This option lets you set when the phone will be locked. When the phone is locked, carrying out most operations requires entering the lock code, however, you can still answer incoming calls and dial 911 or other stored emergency numbers.

1 Push to select "Lock Phone" from the Security menu.

The Lock Phone menu appears.

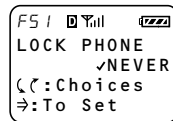

2 Turn to select when the phone will be locked.

You can select "never", "on power-up" or "right now". If you select "never", the phone is available for use at any time without a lock code. If you select "on power-up", the phone is locked every time you turn it on.

3 Push to enter the new setting.

The standby display reappears. The message "=>:Unlock" indicates that the phone is locked.

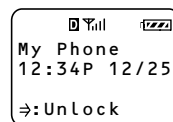

To unlock the phone

On the standby display, push . When prompted, enter the lock code.





Setting a new lock code [F52]

The lock code must be entered every time you want to unlock the phone and also when you want to access restricted numbers.

- 1 Turn to select "New Code" from the Security menu, then push .

The Enter New Code display appears prompting you to enter a new lock code.

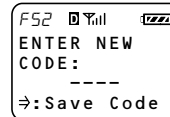

- 2 Use the number buttons to enter a lock code.

The lock code must be exactly four digits long.

- 3 Push to store the new lock code in memory.

A confirmation display appears.

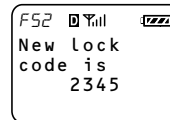

IMPORTANT

Keep a record of your lock code. If you forget it, contact your service provider.

Advanced Features



Restricting a Phone Book entry [F53]

You can restrict access to individual Phone Book entries.

1 Turn to select "Restrict #" from the Security menu, then push .

The following display appears, prompting you to specify the Phone Book entry to be restricted.

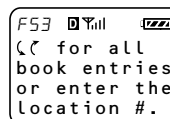

2 Turn to select the Phone Book entry that you want to restrict.

3 Push to restrict the selected entry.

Now the selected entry is restricted.

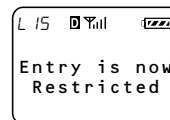

To unrestrict an entry

Follow the procedure for restricting an entry on the previous page to select the entry you want to unrestrict.

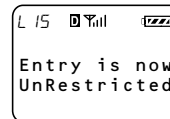

Notes

- The phone number of a restricted entry is not displayed when you view the Phone Book and make a call.
- Restricted entries are not listed or displayed after a digit string search (see pages 34 and 53).
- Calling, editing and erasing a restricted entry requires the four-digit lock code.

Tip

You can also use the Options menu to restrict/unrestrict Phone Book entries (see page 30).





Restricting all Phone Book entries [F54]

You can restrict access to all Phone Book entries. All operations that involve Phone Book entries require the four-digit lock code (see page 60).

- 1 Turn to select "Restrict All" from the Security menu, then push .

The Restrict All menu appears.

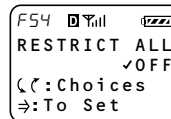

- 2 Turn to set restriction of all Phone Book entries on or off.

- 3 Push to enter the new setting.

The standby display reappears.

Note

If you restricted some entries by using "Restrict #", they are still restricted when you turn off "Restrict All".



Reverting to default settings [F55]

You can reset all menu settings to the defaults. This does not affect Phone Book or Calls List entries.

- 1 Turn to select “Master Reset” from the Security menu, then push .

The Master Reset display appears.

```
F55 0 111 1111
MASTER RESET
1:To Reset
All Settings
⇨:Quit
```

- 2 Press to revert to the factory defaults, or push to keep the current settings.

If you revert to the factory defaults, all your custom menu settings are erased.

```
F55 0 111 1111
-reset-
```



Erasing all Phone Book entries [F56]

You can erase all Phone Book entries at once.

- 1 Turn to select “Erase Book” from the Security menu, then push .

The Erase Book display appears.

```
F56 0 111 1111
ERASE BOOK
1:To Erase
Phone Book
⇨:Quit
```

- 2 Press to erase all Phone Book entries, or push to quit without erasing.

If you erase all entries, the following display appears.

```
F56 0 111 1111
-erased-
```





Erasing all Calls List entries [F57]

You can erase all Calls List entries at once.

- 1 Turn to select "Erase Calls" from the Security menu, then push .

The Erase Calls display appears.

```

F57 0 Yil 1ZZ
ERASE CALLS
1:To Erase
Calls List
⇒:Quit

```

- 2 Press to erase all Calls List entries, or push to quit without erasing.

If you erase all entries, the following display appears.

```

F57 0 Yil 1ZZ
-erased-

```

Storing emergency numbers [F58]

You can use the Security menu to store up to three emergency numbers other than 911 (which you cannot erase). You can call these numbers even when the phone is locked.

- 1 Turn to select "Emergency #" from the Security menu, then push .

The first Emergency # display appears.

```

F58 0 Yil 1ZZ
EMERGENCY #1
(empty)
(():Other #'s
⇒:Edit #

```

- 2 Turn to select the emergency memory location, then push .

A message appears prompting you to enter the phone number for the emergency entry.

- 3 Use the number buttons to enter the number.

- 4 Push to store the emergency number.

The entered emergency number is stored in memory. To store other emergency numbers, repeat the above procedure. To go back to the standby display, hold down .

Advanced Features





Setting display options

You can use the features on the Display menu to change the appearance of the on-screen display.

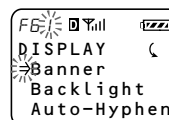

Display menu

Setting the banner [F61]

You can change what the banner reads.

- 1 Push to select "Banner" from the Display menu.

The Banner display appears. The current banner text is displayed.



- 2 Push again to start editing.

A message prompts you to enter a new banner.

- 3 Use the number buttons and to enter the new banner text.

The banner can be up to 12 characters long. For details on character entry, see the "Alphanumeric table" on page 20.

- 4 Push to save the new banner.



The standby display reappears. Your new banner is displayed.





Setting the backlight [F62]

You can adjust the duration of the backlight on the display and keypad.

- 1 Turn  to select "Backlight" from the Display menu, then push .

The Backlight menu appears.

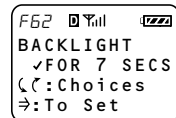

- 2 Turn  to select how long the backlight is on after the last press of a button.

You can select "for 15 secs", "for 7 secs" or "off". If the phone is used in conjunction with a hands-free car kit, a cigarette lighter adapter or a single- or dual-slot battery charger, the added option of "always on" leaves the backlight on.

- 3 Push  to enter the new setting.

The standby display reappears.

Tip

Your phone has two backlight settings: one in charging mode and one in battery mode. The factory setting for charging mode is "always on". For faster charging, you may want to change the setting.

Advanced
Features



Setting autohyphenation [F63]

You can turn the autohyphenation feature on and off. If you turn it on, entered numbers are hyphenated according to the North American Numbering Plan (eleven digits which include a long distance identifier, a three-digit area code, a three-digit community code and a four-digit location code, e.g., 9-999-999-9999).

- 1 Turn to select "Auto-Hyphen" from the Display menu, then push .

The Auto-Hyphen menu appears.

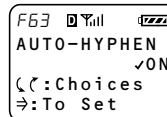

- 2 Turn to select "on" or "off".

- 3 Push to enter the new setting.

The standby display reappears.

Sorting the Phone Book [F64]

You can determine how the Phone Book will be displayed and also set the phone to sort the entries either alphabetically or by memory location.

- 1 Turn to select "Sort Book" from the Display menu, then push .

The Sort Book menu appears.

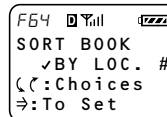

- 2 Turn to set the sorting preferences.

You can choose to sort the Phone Book "by Loc. #" (by location) or "alphabetic" (alphabetically).

- 3 Push to enter the new setting.

The standby display reappears.



Setting your phone's language [F65]

See page 20 for information regarding the Language selection menu.

Setting the menu length [F66]

You can set the menu length (long or short). The short menu displays only the most common items on the Features menu; the long menu displays all items.

- 1 Turn  to select "Menu Length" from the Display menu, then push .

The Menu Length menu appears.

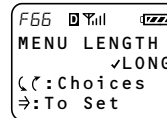

- 2 Turn  to set the menu length.

You can select "short" or "long".

- 3 Push  to enter the new setting.

The standby display reappears.

Items on the short menu

The short menu contains the following items:

- Ringer Vol. (see page 41)
- My Number (see page 48)
- Saved #s (see pages 31, 33, 36)
- Lock Phone (see page 60)
- Long Menu (see pages 86)

Note

The item "Saved #s" contains the items "Find Name" (see page 33), "Phone Book" (see page 31) and "Calls List" (see page 36).

To return to the long menu

On the short menu, turn  to select "Long Menu", then push .





Adjusting network settings

On the Network menu, you can set the phone to alert you when the roaming status changes, when a call is dropped, or when enhanced voice privacy is lost. You can set how NAM's (Number Assignment Modules) are switched, and also activate new services. NAM's are phone identifier numbers associated specifically with your phone. For example, you may have both a business phone number and also a personal phone number associated with your phone.

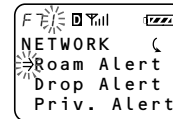

Network menu

Setting the phone's mode [F71]

You can determine whether your dual-band phone switches to analog mode when you roam off the Network. You have three options:

- Automatic (digital or analog) searches for digital service first, then analog service if digital could not be found.
- Disabled (digital only).
- Until OFF (analog only until phone is turned off).

1 Push to select "Set Analog" from the Network menu.

The Set Analog menu appears.

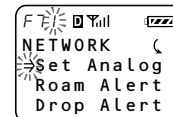

2 Turn to select "disabled", "until OFF", or "automatic".

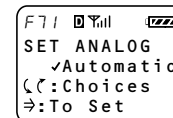

3 Push to enter the new setting.

A message appears corresponding to the mode selected. After a moment, the "Looking for Service" screen is displayed.

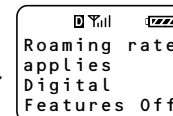

When service has been established, a service area message is displayed followed by the standby screen.



Setting the roaming alert [F72]

Your phone is roaming when you use it outside of the home area. Roaming access to a different carrier and the types of calls you can make varies with the agreement between your "home" carrier and the current serving carrier. Check with your service provider for details about roaming in a specific area.

1 Push to select "Roam Alert" from the Network menu.

The Roam Alert menu appears.

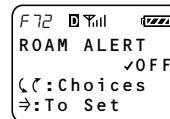

2 Turn to select "on" or "off".

3 Push to enter the new setting.

The standby display reappears.



When you enter another service area

The roaming icon () appears on the display. A beep accompanies the icon if you have turned the roam alert on.



If you leave any valid service area

The following display appears, indicating that you are outside the area serviced by your "home" carrier or other valid service areas. The out-of-service icon () also appears.



If you are in an analog roaming area

The message "Analog Roam" is displayed on the standby display. This message indicates that you are outside your home area, and that you are in an analog service area.





Advanced Features





Setting the drop alert [F73]

If the signal fades, your phone may drop the ongoing call. You can choose to be alerted by an audible alarm when a call is dropped.

- 1 Turn  to select "Drop Alert" from the Network menu, then push .

The Drop Alert menu appears.

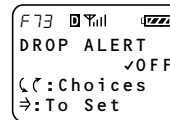

- 2 Turn  to select "on" or "off".

- 3 Push  to enter the new setting.

The standby display reappears.

When a call is dropped

The following display appears. A beep will sound if you have turned the drop alert on.

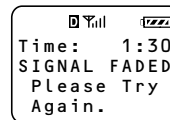



Setting the voice privacy alert [F74]

A display appears to indicate if enhanced voice privacy is lost during a call. You can choose to have an audible alarm accompany this display.

- 1 Turn to select "Priv. Alert" from the Network menu, then push .

The Priv. Alert menu appears.

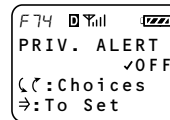

- 2 Turn to select "on" or "off".

- 3 Push to enter the new setting.

The standby display reappears.

If enhanced voice privacy is lost

A display appears advising you that enhanced voice privacy is not available. A beep will sound if you have turned the voice privacy alert on.



When enhanced voice privacy is regained

A display appears notifying you that enhanced voice privacy is once again available. A beep accompanies the display when enhanced voice privacy is regained and you have turned the voice privacy alert on.

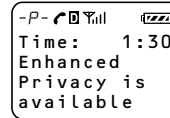

Advanced Features

Note

The network automatically turns on enhanced voice privacy if it is available. You do not have to change your phone settings. For details, contact your service provider.





Switching NAM's automatically [F75]

Your phone allows you to store up to two NAM's (Number Assignment Modules). To add or remove NAM's, contact your service provider who will change the NAM's for you. You can set the phone to switch between them automatically. The phone switches from one NAM to the other if it enters a service provider's coverage area that matches one of your NAM settings. To switch manually, see "Switching NAM's manually" below.

- 1** Turn to select "Auto-N.A.M." from the Network menu, then push .

The Auto-N.A.M. menu appears.

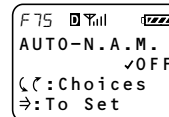

- 2** Turn to set automatic switching on or off.

- 3** Push to enter the new setting.

The standby display reappears.



Switching NAM's manually [F76]

If automatic switching is turned off, you can configure the phone for manual switching between the two NAM's. You must switch from one NAM to the other if the phone enters a service provider's coverage area that matches the other NAM setting. To set the phone to switch automatically, see "Switching NAM's automatically" above.

- 1** Turn to select "Set-N.A.M." from the Network menu, then push .

The Set-N.A.M. menu appears.

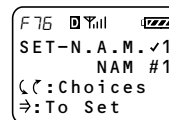

- 2** Turn to switch between the two NAM's.

The display alternately shows the name and the number of the selected NAM.

- 3** Push to enter the new setting.

The standby display reappears.

74





Activating phone services (OTASP) [F77]

You can use the OTASP (Over-The-Air Service Provisioning) activation feature to self-activate your phone with a new service. Contact your service provider to see if this service is available in your area.

- 1** Turn to select "Activation" from the Network menu, then push .

The Activation menu appears.

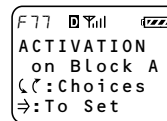

- 2** Turn to select which system block to activate the service on, then push .

The following display appears, prompting you for confirmation. To go back one step, press (CLR). To cancel activation and return to the standby display, press (END).

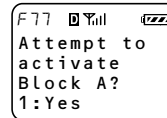

- 3** Press (1) to confirm.

The phone calls up a service provider.

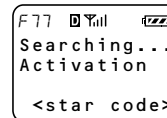

When a service provider is contacted, the following display appears, and you are connected to an operator. When activation is complete, the confirmation display appears followed by the standby display.

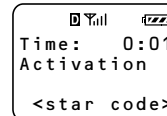

Advanced Features

If activation fails

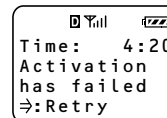

The following display appears. Push to retry, or press (END) to return to the standby display.





System Preference [F78]

Activate the “Home Only” option to ensure that while you are in your home system area, your phone will bypass any other system’s signal that may be stronger than your home system’s signal. This option will help you to avoid higher costs or other calling problems.

- 1 Turn  to select “System Pref.” from the Network menu, then push .

The System Pref. menu appears.

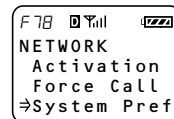

- 2 Turn  to select “Standard” or “Home Only”.

- 3 Push  to enter the new setting.

The standby display reappears.





Using the Short Messaging Service

This section contains information on the Short Messaging Service (SMS). This feature may allow you receive “text” messages as long as there are enough memory locations available.

Contact your service provider to see if this service is available in your area.

Receiving messages

To receive messages, the phone must be turned on. The phone supports three types of messages: “MESSAGE” indicates a text message; “PAGE” typically contains only digits; “VOICE MAIL” is a voice mail notification and indicates the number of new voice mail messages stored in your voice mailbox.

When you receive a message

The message icon (✉) appears on the display accompanied by audible alerts. The first line indicates message type and priority. If the message is urgent, the message type is surrounded by asterisks (*) and followed by an exclamation mark (!). If you press any key, this display disappears. The message icon (✉) remains displayed as long as there are unread messages.

Tip

If you receive duplicate messages, the phone deletes the older one and stores the new one with the indication “DUPLICATE”.

Checking message storage capacity

Voice mail messages

Voice mail messages are stored remotely by your service provider. Your phone will simply notify you if you have any voice mail messages. Check with your service provider to find out the maximum number and length of voice mail messages that can be stored.

Text messages and pages

A text message must contain at least one character and can be up to 200 characters long. The number of messages that can be stored depends on the size of the messages. You can store approximately 7 large messages or 22 small messages.

WARNING

When you receive a new message and your phone does not have enough memory to store it, the phone automatically erases old messages that are not locked.



If the memory becomes full

The phone issues a warning when the memory is approximately 75% full. At this point, you should erase expendable messages (see page 82).



If the memory becomes completely full or your phone does not have enough memory to receive an incoming message, new messages are rejected and the following display appears.

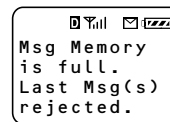

Accessing messages

1 Press from the standby display.

The Messages display appears indicating the number of the following types of messages, respectively:

- Voice mail messages (see page 83).
- Unread text messages and pagings (see the next section).
- Text messages and pagings that you have already read but are still stored in memory (see page 79).



Reading text messages

You can read both new and old messages stored in memory. After reading messages, you can protect or erase them.

To read new messages

1 From the Messages display, turn to select "New Text", then push .

The first message is displayed. If there are no new messages, the following display appears. Push to return to the Messages display.

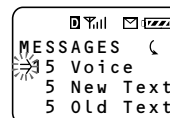

2 Turn to scroll through the message.

If you do not scroll, the display automatically scrolls down. A hollow box (□) indicates the end of the message.





3 To proceed to the next message, push  when you reach the end of the message.

The Options menu appears. To return to the standby display, press **END**.

4 Turn  to select "Next Msg", then push .

The next message is displayed. If there are no more messages, the Messages display reappears.



To read old messages

1 From the Messages display, turn  to select "Old Text", then push .

A list of old messages is displayed. An asterisk (*) indicates an urgent message. A lock icon () indicates that the message is locked (see page 80). If a number is too long to fit, an ellipsis (...) is used.

2 Turn  to scroll through the list of old messages.

3 To read the selected message, push .

The selected message is displayed.

4 Turn  to scroll through the message.

If you do not scroll, the display automatically scrolls down to the end of the message, which is indicated with a hollow box (.

5 When you have read the message, press **CLR to return to the list of old messages.**

To return to the Messages display, press **M**.

To read the next message, push  to go to the Options menu, then select "Next Msg".



To protect a text message

You can lock a message to protect it from being erased.

1 After reading a message, push .

The Options menu appears.

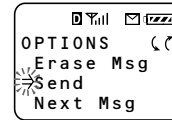

2 Turn to select "Lock Msg", then push .

The following display appears and the message is now locked.

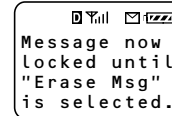

Note

The phone does not erase locked messages automatically. When there is not enough memory for incoming messages, you must erase the locked messages manually.



To respond to a text message

1 After reading a text message, push .

The Options menu appears.

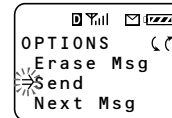

2 Turn to select "Send", then push .

The phone dials the callback phone number which is attached to the message.

If the callback number is not attached to the message, no call is made and the following message is displayed.

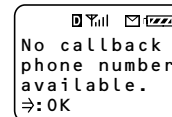

Tip

You can also dial the callback phone number by pressing  when viewing a text message or the list of old messages.





To save the callback number

1 After reading a message, push .



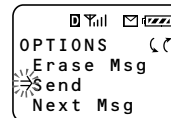

The Options menu appears.



2 Turn to select "Save Number", then push .

A message appears prompting you for a name to accompany the number.



3 Use the number buttons to enter the name.

If you press the same button in quick succession, the letter you just entered changes. (See the "Alphanumeric table" on page 20.) Use  /  or  to move the cursor and to insert spaces between characters. If you enter the wrong character, press  to clear the character highlighted by the cursor.

4 When you are finished, push to store the phone number and name.

A message appears prompting you to confirm the save procedure.

5 Push to store the new number in the first available memory location.

If you want to store it in another location, turn  to select the desired location, then push .

A confirmation message appears, followed by the status of the Phone Book.

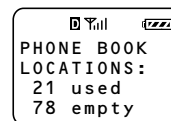

Advanced Features



To erase a text message

- 1 After reading a text message, push . The Options menu appears.

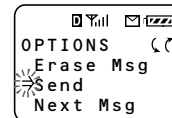

- 2 Turn to select "Erase Msg", then push . The message is erased.

To erase all old text messages

- 1 Turn down to select "Erase Old" from the Messages display, then push . If the Messages display is not shown, press , then select "Erase Old".

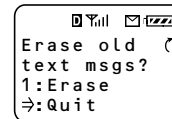

- 2 Press to erase all old messages. To go back to the Messages display without erasing the messages, push .

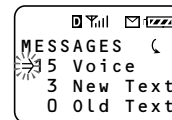



Reading voice mail notification messages

- 1 From the Messages display, turn to select "Voice", then push .

A message appears indicating the number of voice messages stored in your voice mailbox. Press **CLR** to go back to the Messages display.



- 2 Turn to scroll through the message.
A hollow box (□) indicates the end of the message.

To dial a callback number

- 1 After reading a voice mail notification message, push . The Options menu appears.

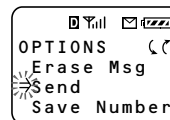

- 2 Turn to select "Send", then push . The phone dials the callback phone number which is attached to the message.

Tip

You can also dial the callback phone number by pressing **SEND** from the Messages display or when reading a voice mail notification message.

Advanced Features



To erase a voice message

- 1 After reading a voice mail notification message, push .**
The Options menu appears.

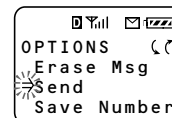

- 2 Turn  to select "Erase Msg", then push .**
The voice mail notification message is erased. The Messages display reappears, indicating that there are currently no voice mail notification messages stored in memory.

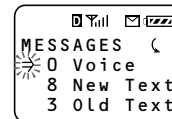



Troubleshooting

Problem	Possible solutions	Page
Nothing appears on the display.	• The phone is off. Turn the phone on.	18
	• Battery is fully discharged. Recharge the battery.	16
	• Battery may not be completely attached. Securely attach the battery.	15
Out-of Service icon (ⓧ) appears.	• The phone is outside the service area, or the signal is too weak. Extend the antenna fully.	18
	• Check NAM settings on the Network menu. If you set "Auto-NAM" to "off" and you are using two NAM's, the phone may be ignoring an available service.	74
Nothing happens when you press the buttons.	• The buttons may be locked.	56
	• The phone may be locked. Enter the lock code to unlock the phone.	60
The call does not go through.	• Check the signal strength.	18
	• If the out-of-service icon (ⓧ) is displayed, there is no service. See above.	18
	• Check the number.	21
	• Press (SEND).	21
	• Listen for a busy signal.	—
You hear the caller, but the caller cannot hear you.	• The microphone may be muted. Unmute the microphone.	22, 42
	• Adjust the earpiece volume. If possible, also reduce the noise around you.	22, 43
The call is cut off ("dropped").	• You are possibly out of the coverage area. Redial the number. If the problem continues, contact your carrier. Also see "Out-of-service icon (ⓧ) appears" above.	18
You hear an alternate high/low tone.	• You are attempting to use the phone in an area without service.	18
	• Extend the antenna fully.	18
	• Wait for the out-of-service icon (ⓧ) to disappear, then try to dial.	18
You forgot the lock code.	• Try 0000, 1234 (commonly used as defaults), or the last four digits of your own number. • See your authorized dealer or service provider.	60 —
You hear a fast busy tone.	• The fast busy tone can result from any one of the following problems:	—
	– The phone is improperly programmed.	—
	– The phone is out of range.	18
	– All channels are busy.	—
You cannot place or receive calls.	– The antenna is broken or damaged.	18
	• Make sure that the phone is turned on, and that out-of-service icon (ⓧ) is not displayed.	18
	• Check system settings. If you are roaming, consult your service provider concerning roaming agreements.	71

Additional Information



List of menu items

This section lists the Features menu and its submenus. Use these to set the various parameters that pertain to the operation of the phone. For details on how to navigate from one menu to another, see “About the Features menus” on page 37.

Menu Item	Settings	Page
Submenu F-1 Sounds		
F11 Ringer Vol.	off / low / medium / high / escalate	41
F12 Mute/UnMute	mutes or unmutes the microphone	42
F13 Keybeep Vol	off / low / medium / high	42
F14 Earpiece Vol	1 / 2 / 3 / 4 / 5 / 6 / 7	43
F15 Ringer Type	standard / option 1 to 4	43
F16 Key Sound	tones / clicks	44
F17 Beep Length	standard / long	44
Submenu F-2 Timers		
F21 All Calls	total call time, number of calls	45
F22 Recent Calls	total call time, number of calls	45
F23 Minute Alert	on / off	46
F24 Auto-Off	never / in 3 hours / in 2 hours / in 1 hour / in 30 mins	47
Submenu F-3 Directory		
F31 My Number	—	48
F32 Save	—	48
F33 Erase	—	50
F34 Edit	—	51
F35 Find Name	—	52
F36 Phone Book	No default entries	54
F37 Calls List	No default entries	55
Submenu F-4 Extras		
F41 Keyguard	—	56
F42 Touch Dial	on / off	57
F43 Auto-Retry	off / on 60 sec / on 30 sec / on 10 sec	57
F44 Auto-Answer	on / off	58
F45 Any Key Answ	on / off	58
F46 Scratch Pad	—	59



Menu Item	Settings	Page
Submenu F-5 Security		
F51 Lock Phone	never / on power-up / right now	60
F52 New Code	0000	61
F53 Restrict #	No default restricted numbers	62
F54 Restrict All	on / off	63
F55 Master Reset	—	64
F56 Erase Book	—	64
F57 Erase Calls	—	65
F58 Emergency #	No default numbers for #1 to #3	65
Submenu F-6 Display		
F61 Banner	No default banner	66
F62 Backlight	off / for 7 secs / for 15 secs / always on	67
F63 Auto-hyphen	on / off	68
F64 Sort Book	by loc. # / alphabetic	68
F65 Language	English / French / Spanish	20
F66 Menu Length	long / short	69
Submenu F-7 Network		
F71 Set Analog	disabled / until off / automatic	70
F72 Roam Alert	on / off	71
F73 Drop Alert	on / off	72
F74 Priv. Alert	on / off	73
F75 Auto-N.A.M.	on / off	74
F76 Set-N.A.M.	N.A.M. 1 / N.A.M. 2	74
F77 Activation	—	75
F78 System Pref.	standard / home only	76

Additional
Information





Specifications

Frequency range	CDMA Transmit: 1851.25 to 1908.75 MHz CDMA Receive: 1931.25 to 1988.75 MHz FM Transmit: 824.04 to 848.97 MHz FM Receive: 869.04 to 893.97 MHz
Dimensions (h/w/d)	5.7 x 2.0 x 1.5 inches (146 x 50 x 37 mm) (not including antenna)
Mass (weight)	Approx. 7.7 oz (203 g) (including battery)
RF power output	CDMA: 0.01 μ W to 420 mW FM: 4.9 mW to 600 mW
Operational temperature	-22°F to +140°F (-30°C to +60°C) (excluding battery pack)
Supplied accessories	QN-003BPLH Hi-Cap Li-Ion Battery Pack (1) QN-001AC AC Adapter (1) Hand strap (1)

Design and specifications are subject to change without notice.

Enhanced Variable Rate Codec available.



Optional accessories

- QN-002BCD Dual Slot Battery Charger
- QN-003BPLH Hi-Cap Li-Ion Battery Pack
- QN-004BPLS Slim Li-Ion Battery Pack
- QN-008CLA Rapid Charging Cigarette Lighter Adapter
- QN-009TA Travel Adapter
- QN-010LC Carrying Case (for CM-M1300, B1200, S1100 series telephones)
- QN-012DAS FoneBook PLUS Software with Interface Cable
- QN-013HC Auto Travel Holder
- QN-016SKT Starter Kit (QN-010LC Carrying Case, Single Slot Charging Stand, Rapid Charging Cigarette Lighter Adapter)
- QN-017SKT Starter Kit (QN-019LC Carrying Case, Single Slot Charging Stand, Rapid Charging Cigarette Lighter Adapter)
- QN-018SKT Starter Kit (QN-018LC Carrying Case, Single Slot Charging Stand, Rapid Charging Cigarette Lighter Adapter)
- QN-018LC Carrying Case (for CM-M2300, B2200, S2100 series telephones)
- QN-019LC Carrying Case (for CM-M3300, B3200, S3100 series telephones)
- QN-020TCL Combination Travel Adapter/Cigarette Lighter Adapter
- QN-025PHK Portable Hands-Free Car Kit
- QN-035HFK Hands-Free Car Kit

Call 1-800-488-SONY (7669) to order additional accessories (USA only).

Additional Information



Glossary

A

Automatic answer

Feature that automatically answers calls.

Automatic NAM

Feature that automatically selects an available NAM that matches the current serving system (carrier).

Automatic retry

Feature that automatically redials a call when a "System Busy" indication is received.

B

Banner

Message at the top of the standby display.

C

Calls List

See "Phone Book".

Carrier

A company that provides cellular and PCS telephone service.

CDMA

Code Division Multiple Access. A spread-spectrum approach to digital transmission. With CDMA, each conversation is digitized and then tagged with a code. The mobile phone receives only the signal with the appropriate code.

Coverage area

The geographic area covered by one carrier. If you travel outside a carrier's area, you cannot receive service from that carrier. Also see "Roam".

90

D

Dropped call

A call terminated because of a deep, long fade or because the user left the coverage area.

DTMF

Dual Tone Multiple Frequency, also known as "touch-tone". Tone generated when you press a telephone button (number, * or #). Can be used to access answering machines, pagers, telephone banking services, data services and other electronic services.

E

ESN

Electronic Serial Number. The unique identification number of your telephone. The telephone transmits this number to the base station every time a call is placed.

Emergency number

In addition to the general emergency number (911 for the USA and Canada), three phone numbers can be stored as emergency numbers in your telephone. You can dial these numbers and 911 even when the phone is locked.

H

Home area

The area of the home system to which you subscribe.

I

Incoming call

A call received by your telephone.



K

Keyguard

A feature that allows you to lock the phone's keypad for low level security.

L

Lock

Prevents unauthorized calls by requiring the user to enter a code to use the phone. Even if the phone is locked, you can call any of the emergency numbers or answer incoming calls.

M

Memory

A storage area for names and phone numbers. Also see "Phone Book".

Menu

The menu allows you to change or see the settings of your phone. You can access it from the standby display or during a call. See "List of menu items" on page 86 for an overview of this feature.

Minute alert

This alert beeps periodically during a call to help you keep track of the length of the call.

Multiple NAM registration

Registering your phone in more than one carrier. A cheaper alternative to roaming. If you travel frequently to a specific area, registering the local carrier in your phone's NAM's may be an economical alternative to roaming and long distance charges.

N

NAM

Number Assignment Module. Portion of your telephone's memory programmed to contain information about your subscription to the carrier. Your telephone can have up to two NAM's.

P

Pause

You can insert a Time Pause or Hard Pause in the phone number memory data. A pause causes the phone to wait (either for a specified time or until manually released) before sending a second string of digits, ensuring your counterpart (e.g., answering machine, voice mail system, electronic banking system, etc.) is ready to accept the string.

Phone Book

You can store up to 99 numbers in Phone Book memory, location number 01 to number 99. An additional recent number memory (Calls List) stores the last ten used phone numbers.

R

Roam

Your phone is roaming when you use it outside of the home area. Availability of roaming access to a different carrier and types of calls you can make varies with the agreement between your home carrier and serving carrier. Check with your carrier for details about roaming in a specific area.

Additional
Information





S

Scratch pad

Allows you to enter a number and store it in the Calls List.

Service area

Region covered by a cellular/PCS service. Also see "Coverage area".

SMS

Short Messaging Service. An extended service offered by carriers that allows you to receive text messages on your phone. Check with your carrier for details.

Speed dialing

Making a call using Phone Book memory locations. Also see "Phone Book".

T

Touch dialing

A quick way of making a call using a number stored in a Phone Book memory location. Also see "Speed dialing".

Touch-tone

See "DTMF".

V

Voice mail

An extended service, offered by carriers, that allows you to retrieve voice mail messages stored in your voice mailbox. Check with your carrier for details.

Volume

You can adjust the volume of keybeep, ringer and earpiece.





Index

A

- AC adapter 10, 16
- Antenna 18
- Automatic
 - Answer 58
 - Hyphenation 68
 - Redial 57
 - Retry 57

B

- Backlight 67
- Banner 66
- Battery charge contacts 16
- Battery icon 16, 17
- Battery pack
 - Attaching/removing 15
 - Charging 16
 - Checking 17
- Battery pack release tab 15

C

- Calling
 - Calls List 36, 55
 - Dropped call 72
 - Ending calls 21, 23
 - Making calls 21
 - Missed call 24
 - Receiving calls 23
 - Recent number 36
 - Redialing 22, 57
 - Restrictions 30, 60
 - Roaming 71
 - Speed dialing 32
 - Touch dialing 32, 57
- Carrier 71
- CDMA (Code Division Multiple Access) 5
- Character display 14
- Clearing. *See* Deleting
- Coverage area 71
- Cursor 25, 49

D

- Dialing. *See* Calling
- Deleting
 - Calls List entries 65
 - Characters 26, 50
 - Message 82
 - Phone Book entries 29, 50
 - Phone numbers 29, 50
 - Voice mail 84
- Digital icon 14
- Display 14
- Display settings
 - Accessing 39
 - Autohyphenation 68
 - Backlight 67
 - Banner 66
 - Time 45
- Displays
 - Calling 21
 - Features menu 39
 - Hyphens/pauses/links 27
 - Menu setting 69
 - Security 60
 - Standby 18
- Dropped call 72
- DTMF (Dual Tone Multiple Frequency) 38

E

- Earpiece 22, 43
- Editing
 - Emergency numbers 65
 - Phone numbers 28, 51
- Emergency numbers 65
- Enabling
 - Lock 56
 - Touch dialing 57
- Ending a call 21, 23
- Entering
 - Hyphens 27
 - Links 27
 - Pauses 27
- Erasing. *See* Deleting
- ESN (Electronic Serial Number) 90



F

Finding. *See* Searching

H

Hand strap
Attaching 11
Home Only 76
Hyphens
Autohyphenation 68
Entering manually 27

I

Incoming call 23
In-use icon 21, 23

J

Jog Dial 19

K

Keybeep 42
Keyguard 56
Keypad lock icon 56

L

Language selection 20
Laws
Rules and regulations 3
Link 27
Lock code 60
Locking the keypad 56

M

Making calls 21
Manual
Answer 23
Call 21
Hyphenation 27
Redial 22

94

Memory

Deleting 29, 50
Editing 28, 51
Number searching 33, 52, 53
Storing 25, 48

Menus

Accessing 39
Message button 78
Message icon 77

Messages

Calling back 80
Displaying 78
Erasing 82
Locking 80
Message list 78
Receiving 77
Microphone 22, 42
Minute alert 46
Multiple city registration 91
Muting the microphone 22, 42
Muting the ringer 23, 41

N

NAM (Number Assignment
Module) 70, 74
Number buttons 21, 25

O

Out-of-service icon 18, 21, 23, 71
Over-the-Air Service
Provisioning (OTASP) 75
Overflow digits
Viewing 37

P

Pause 27
Phone Book 25, 31, 33, 48
Power
Turning off 18
Turning on 18





Q

Quitting. *See* Power

R

Receiving
 Calls 23
 Messages 77
 Voice mail 83

Recent number memory
 Calling recent numbers 36
 Clearing call memory 64

Redialing
 Auto-retry 57
 Last dialed number 22

Restriction 30, 60

Ringer
 Speaker 12, 13
 Volume 41

Roam
 Roam icon 71
 Roaming agreement 71

Rules and regulations 3

S

Safety precautions 5

Scratch pad 59

Scrolling
 Menus 19
 Message 78
 Message list 79

Searching
 For a message 79
 For a name 52
 For a number 33-35

Security code. *See* Security functions

Security functions
 Accessing 60
 Clearing call memory 64
 Emergency numbers 65
 Lock mode 60
 New lock code 61
 Restriction 62

Sending. *See* Calling

Service area 71

Signal strength icon 18

SMS (Short Messaging Service) 77

Special characters 20

Special features
 Accessing 56
 Changing DTMF transmission 44
 Enabling touch dialing 57
 Muting the microphone 42
 Muting the ringer 23, 41
 Setting auto-answer 58
 Setting auto-retry 58
 Using the scratch pad 59

Standby display 18

System preferences 76

System settings
 Accessing 70
 Analog 70
 Over-the-Air Service Provisioning (OTASP) 75
 Selecting NAM's
 Auto-NAM 74
 Manual NAM 74

T

Text Message. *See* Messages

Touch dialing
 Enabling 57

Troubleshooting 85

Turning phone on 18

V

Voice mail notification
 Accessing 83
 Receiving 83

Voice Privacy 73

Volume
 Adjusting 41

Additional Information





SONY Wireless Hotline Number (USA only)

If you have any questions or comments, please call:
SONY WIRELESS HOTLINE
1-800-578-SONY (7669)

Visit our website at www.sony.com/wireless
to register your product online and
find out about additional Sony technology

Printed in USA

