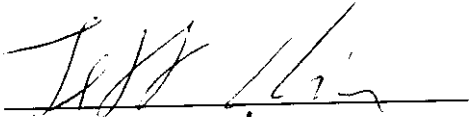
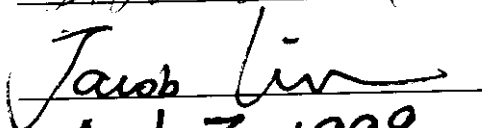
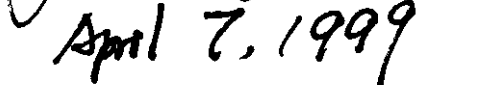

| | |
|---|--|
| Report No. | C0915134 |
| Specifications Test Method | FCC Part 15.109(g), Class B ANSI C63.4 1992 |
| Applicant address | 16F, No. 75 Hsin Tai Wu RD., Sec. 1 Bldg #A Hsi-Chih, Taipei Hsien, Taiwan |
| Applicant Items tested Model No. | CIS TECHNOLOGY INC. Internal 56K Fax/Data Modem WS-5614HMM (Sample # C09134) |
| Results Sample received data | Compliance (As detailed within this report) 03/30/1999 (month / day / year) |
| Prepared by |  project engineer |
| Authorized by |  Vice General Manager (Jacob Lin) |
| Issue date |  April 7, 1999 (month / day / year) |
| Modifications | None |
| Tested by Office and Open site at | Training Research Co., Ltd. No. 15, Lane 530, Pa-Lian RD., Sec. 1, Hsi-Chih Town, Taipei Hsien, Taiwan, R.O.C. |

Conditions of issue:

- (1) **This test report shall not be reproduced except in full, without written approval of TRC. And the test result contained within this report only relate to the sample submitted for testing.**
- (2) **This report must not be used by the client to claim product endorsement by NVLAP or any agency of U.S. Government.**

FCC ID : L4OWS-5614HMM

Contents

Chapter 1 Introduction

| | |
|----------------------------------|---|
| Description of EUT..... | 3 |
| Configuration of Test Setup..... | 4 |
| List of Support Equipment..... | 5 |

Chapter 2 Conducted Emission Test

| | |
|-------------------------------|---|
| Test Condition and Setup..... | 7 |
| Conducted Test Placement..... | 8 |

Chapter 3 Radiated Emission Test

| | |
|-------------------------------|----|
| Test Condition and Setup..... | 9 |
| Radiated Test Placement..... | 10 |

Appendix A:

| | |
|----------------------------|----|
| Conducted test result..... | 11 |
|----------------------------|----|

Appendix B:

| | |
|---------------------------|----|
| Radiated test result..... | 12 |
|---------------------------|----|

Chapter 1 Introduction

Description of EUT:

This 56K Fax/Data modem card is a data communication device. It is designed to install in the personal computer and makes your data equipment available to transmit and receive data via the public telephone network.

Connections of EUT:

- (1) Put the EUT into a personal computer's bus and screw it.
- (2) Line jack of EUT connects with a line cable to the PABX located remotely.
- (3) Phone jack of EUT connects with a telephone set.

Test method:

Pretest was found that the emission of operating mode is worse than standby mode. So, The final test is made at the operating mode.

During testing, the EUT was operated at "transmitting" and "receiving" mode simultaneously.

While testing, the transmitting rate was set to "AUTO" which means it transmitted the test file depending on the telephone line condition, normally the operating rate is the highest speed. The test placement as the photographs showed is the worst case emission placed. (If the emission is close to the ambient, the resolution BW and view resolution will be reduced and the data will be recorded by detection of maximum hold peak mode.)

The testing configuration of test setup is showing in the next page.

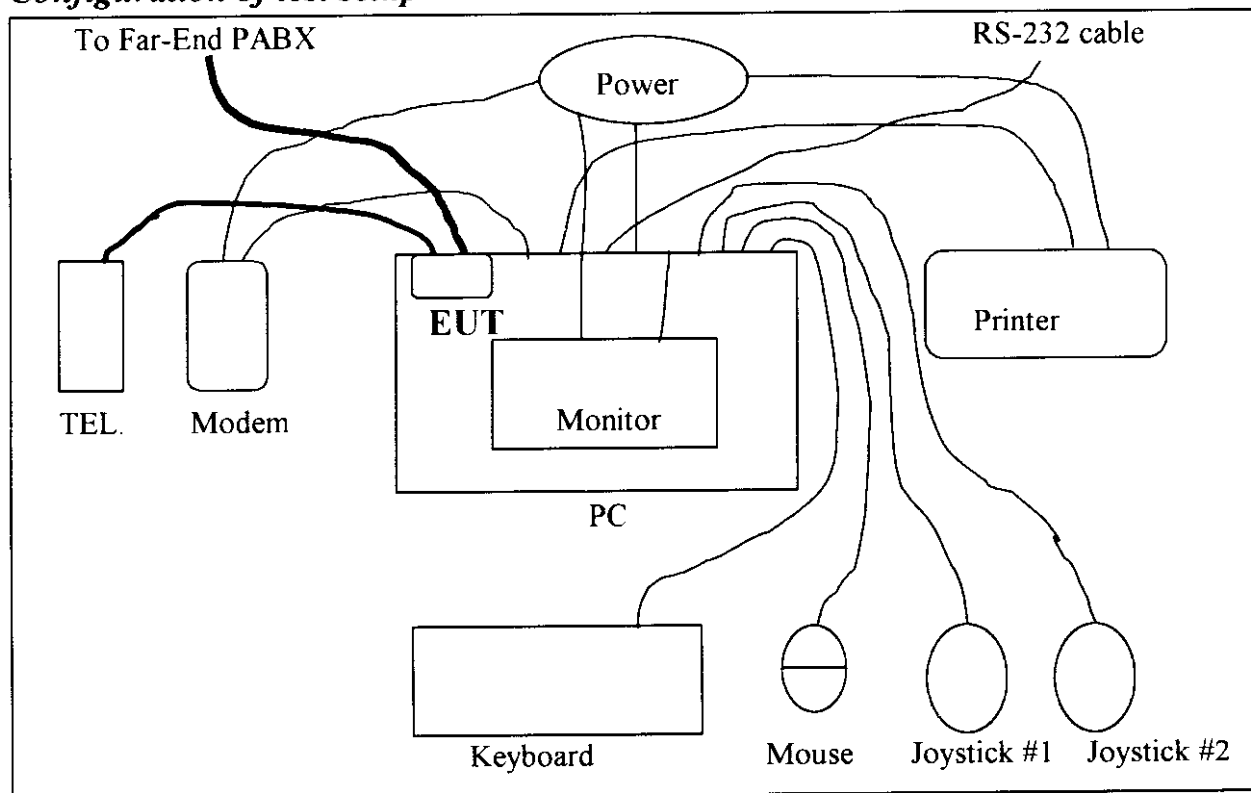
Configuration of test setup**Connections:****PC:**

- *Serial A port --- a external modem
 - *Serial B port --- a RS-232 cable left unterminal
 - *Printer port --- a Printer
 - *Monitor port --- a monitor
 - *Keyboard port --- a Keyboard
 - *Mouse port --- a Mouse
 - *USB ports --- two USB joysticks.
- (Each port on PC is connected with suitable device)

EUT:

- *Line jack --- via 15 m RJ11C cable to PABX located remotely
- *Phone jack --- via a 7 feet RJ11C cable to telephone set

List of support equipment

Conducted (Radiated) test:

PC : HP
Model : VE6/350 SERIES 8
Serial No. : SG91002329
FCC ID : DoC Approval
Power type : AC 100~127 / 200~240 VAC, Switching
Power cord : non-Shielded, 1.7m long, Plastic, no ferrite core

Monitor : HP
Model No. : D2821
Serial No. : TW 73512262 (TW 73147163)
FCC ID : A3KMO64
Power type : AC 110~120 / 220~240 VAC, Switching
Power cord : Non-Shielded, 3m long, no ferrite core
Data cable : Shielded, 1.8m long, with ferrite core

Keyboard : Digital
Model No. : KB-5923
Serial No. : 9S74904837 (9S74904665)
FCC ID : E8HKB-5923
Power type : By PC
Data cable : Shielded, 1.8m long, with ferrite core

Printer : HP
Model No. : C2642A
Serial No. : SG69A196GV
FCC ID : B94C2642X
Power type : 220 VAC, 50Hz
Power cord : Non-shielded, 2m long, no ferrite core
Data cable : Shielded, 1.84m long, no ferrite core (1.7m)

Modem : **ACEEX**
Model No. : XDM-9624
FCC ID : IFAXDM-9624
Power type : 220VAC, 50Hz/ 9VAC, 1A
Power cord : Non-shielded, 1.9m long, no ferrite cord
Data cable : RS232, Shielded, 1.2m long, no ferrite core
RJ11C x 2, 7' long non-shielded, no ferrite core

Mouse : **Hewlett Packard Mouse**
Model No. : C3751B
Serial No. : LCA52707170
FCC ID : DZL210582
Power type : Powered by PC
Power Cable : Non – Shielded. 5.5' long, Plastic hoods, No ferrite bead

Joystick : **Padix**
Model : QF-606U, QF-707U (DoC Approval)
Power Type : By PC

PABX : **King Design**
Model No. : KD8705-A
Serial No. : GV101101186
Power type : 220VAC, 50Hz
Power cord : Non - Shielded

Chapter 2 Conducted emission test

Test condition and setup:

All the equipment is placed and setup according to the CISPR 22. The EUT is assembled on a wooden table that is 80 cm high, is placed 40 cm from the back-wall which is a vertical conducting plane. One LISN is for EUT, the other LISN is for support equipment. They are all placed on the conductive ground. The EUT's LISN connect a line switch box for selecting L1 or L2, then connect to a preamplifier and spectrum.

The spectrum scans from 150KHz to 30MHz. Conducted emission levels are detected at max. peak mode. But if the max. peak mode failed, it will be measured by CISPR's quasi-peak detection mode.

While testing, there is the worst-emission plot printed at peak detection mode, and there are more than 6 highest emissions relative to limit recorded. The plot is kept as the original data, not included in test report.

List of test Instrument:

| <u>Instrument Name</u> | <u>Model No.</u> | <u>Brand</u> | <u>Serial No.</u> | <u>Calibration Date</u> | |
|------------------------|------------------|--------------|-------------------|-------------------------|------------------|
| | | | | <u>Last time</u> | <u>Next time</u> |
| Spectrum analyzer | 8594EM | H P | 3710A00279 | 01/07/99 | 01/07/00 |
| LISN (EUT) | 3825/2 | EMCO | 9411-2284 | 05/15/98 | 05/15/99 |
| LISN (Support E.) | AC3-001 | TRC | ----- | 05/15/98 | 05/15/99 |
| Preamplifier | AC3-002 | TRC | ----- | 05/15/98 | 05/15/99 |
| Line switch box | AC3-003 | TRC | ----- | 05/15/98 | 05/15/99 |

The level of confidence of 95%, the uncertainty of measurement of conducted emission is ± 2.4 dB.

Test Result: Pass (Appendix A)

Chapter 3 Radiated emission test

Test condition and setup:

Pretest: Prior to the final test (OATS test), the EUT is placed in a anechoic chamber and scan from 30MHz to 1GHz. This is done to ensure the radiation exactly emits form the EUT.

Final test: Final radiation measurements are made on a **10 - meter, open-field** test site. The EUT is placed on a nonconductive table that is 0.8m height, the top surface is 1.0 x 1.5 meter. The placement is according to CISPR 22.

The spectrum is examined from 30 MHz to 1000 MHz measured by HP spectrum.

The EMCO whole range Antenna is used to measure frequency from 30 MHz to 1GHz. The final test is used the spectrum HP 8594EM.

Measure more than six top marked frequencies generated form pretest by computer step by step at each frequency. The EUT is rotated 360 degrees, and antenna is raised and lowered from 1 to 4 meters to find the maximum emission levels. The antenna is used with both horizontal and vertical polarization.

Appropriated preamplifier which is made by TRC is used for improving sensitivity and precautions is taken to avoid overloading. The spectrum analyzer's 6dB bandwidth is set to 120 KHz, and the EUT is measured at quasi-peak mode.

If the emission is close to the frequency band of ambient, the data will be rechecked by the tester and the corrected data will be written in the test data sheet. If the emission is just within the ambient, the data from anechoic chamber will be taken as the final data.

| List of test Instrument: | Calibration Date | | | | |
|--|-------------------------|------------------|--------------|-------------------|-------------|
| | <u>Instrument Name</u> | <u>Model No.</u> | <u>Brand</u> | <u>Serial No.</u> | <u>Last</u> |
| Spectrum analyzer | 8594EM | H P | 3619A00198 | 11/17/98 | 11/17/99 |
| RF Pre-selector | AC4-001 | TRC | ----- | 05/15/98 | 05/15/99 |
| Antenna (30M-2G Hz) | 3141 | EMCO | 9711-1076 | 12/17/98 | 12/17/99 |
| Open test side (Antenna, Amplify, cable calibrated together) | | | | 05/15/98 | 05/15/99 |

The level of confidence of 95%, the uncertainty of measurement of radiated emission is ± 4.96 dB.

Test Result: Pass (Appendix B)

Appendix A

Conducted Emission Test Result:

Testing room : Temperature : 21 ° C Humidity : 49 % RH

Line 1

| FREQUENCY (KHz) | READING AMPLITUDE | | | LIMIT | | MARGIN (dB) |
|---------------------|-------------------|------------------------|---------------------|------------------------|---------------------|------------------|
| | Peak (dBμV/m) | Quasi-peak (dBμV/m) | Average (dBμV/m) | Quasi-Peak (dBμV/m) | Average (dBμV/m) | |
| 310 | 35.74 | *** ** | *** ** | 61.43 | 51.43 | -15.69 |
| 464 | 34.98 | *** ** | *** ** | 57.03 | 47.03 | -12.05 |
| 620 | 36.61 | *** ** | *** ** | 56.00 | 46.00 | -9.39 |
| 773 | 36.38 | *** ** | *** ** | 56.00 | 46.00 | -9.62 |
| 922 | 32.94 | *** ** | *** ** | 56.00 | 46.00 | -13.06 |
| 1077 | 31.43 | *** ** | *** ** | 56.00 | 46.00 | -14.57 |
| 1390 | 31.35 | *** ** | *** ** | 56.00 | 46.00 | -14.65 |
| 1545 | 30.57 | *** ** | *** ** | 56.00 | 46.00 | -15.43 |
| 4580 | 30.68 | *** ** | *** ** | 56.00 | 46.00 | -15.32 |
| 7660 | 35.02 | *** ** | *** ** | 60.00 | 50.00 | -14.98 |

Line 2

| FREQUENCY (KHz) | READING AMPLITUDE | | | LIMIT | | MARGIN (dB) |
|---------------------|-------------------|------------------------|---------------------|------------------------|---------------------|------------------|
| | Peak (dBμV/m) | Quasi-peak (dBμV/m) | Average (dBμV/m) | Quasi-Peak (dBμV/m) | Average (dBμV/m) | |
| 215 | 41.49 | *** ** | *** ** | 64.14 | 54.14 | -12.65 |
| 308 | 36.89 | *** ** | *** ** | 61.49 | 51.49 | -14.60 |
| 464 | 36.08 | *** ** | *** ** | 57.03 | 47.03 | -10.95 |
| 542 | 30.53 | *** ** | *** ** | 56.00 | 46.00 | -15.47 |
| 620 | 36.89 | *** ** | *** ** | 56.00 | 46.00 | -9.11 |
| 645 | 31.74 | *** ** | *** ** | 56.00 | 46.00 | -14.26 |
| 773 | 36.37 | *** ** | *** ** | 56.00 | 46.00 | -9.63 |
| 922 | 32.34 | *** ** | *** ** | 56.00 | 46.00 | -13.66 |
| 1516 | 31.37 | *** ** | *** ** | 56.00 | 46.00 | -14.63 |
| 7660 | 35.38 | *** ** | *** ** | 60.00 | 50.00 | -14.62 |

* The reading amplitudes are all under average limit.

Appendix B

Radiated Emission Test Result: (Horizontal)

Test Conditions:

Testing room : Temperature : 20 ° C Humidity : 69 % RH
 Testing site : Temperature : 21 ° C Humidity : 67 % RH

| Frequency | Reading Amplitude | Ant. Height | Table | Correction Factors | Corrected Amplitude | Class B limit | Margin |
|-----------|-------------------|-------------|--------|--------------------|---------------------|---------------|--------|
| MHz | dBμV | m | degree | dB/m | dBμV/m | dBμV/m | dB |

| | | | | | | | |
|---------|-------|------|-----|--------|-------|-------|-------|
| 620.980 | 47.40 | 4.00 | 200 | -16.15 | 31.25 | 37.00 | -5.75 |
| 736.550 | 46.63 | 0.99 | 206 | -15.46 | 31.17 | 37.00 | -5.83 |
| *** | | | | | | | |
| | | | | | | | |
| | | | | | | | |
| | | | | | | | |
| | | | | | | | |
| | | | | | | | |
| | | | | | | | |
| | | | | | | | |

Note:

1. Margin = Amplitude - limit, if margin is minus means under limit.
2. Corrected Amplitude = Reading Amplitude + Correction Factors
3. Correction factor = Antenna factor + (Cable Loss - Amplitude gain)
 (For example: 30MHz correction factor = 15.5 + (-15.26) = 0.24 dB/m)

Radiated Emission Test Result: (Vertical)

| Frequency | Reading Amplitude | Ant. Height | Table | Correction Factors | Corrected Amplitude | Class B limit | Margin |
|-----------|-------------------|-------------|--------|--------------------|---------------------|---------------|--------|
| MHz | dB μ V | m | degree | dB/m | dB μ V/m | dB μ V/m | dB |

| | | | | | | | |
|---------|-------|------|-----|--------|-------|-------|-------|
| 621.020 | 46.27 | 4.01 | 77 | -16.15 | 30.12 | 37.00 | -6.88 |
| 736.550 | 47.76 | 2.51 | 134 | -15.46 | 32.30 | 37.00 | -4.70 |
| 762.060 | 49.89 | 2.51 | 43 | -16.83 | 33.06 | 37.00 | -3.94 |
| 863.670 | 52.88 | 4.00 | 19 | -19.21 | 33.67 | 37.00 | -3.33 |
| 965.290 | 48.39 | 4.01 | 336 | -16.50 | 31.89 | 37.00 | -5.11 |
| *** | | | | | | | |
| | | | | | | | |
| | | | | | | | |
| | | | | | | | |
| | | | | | | | |
| | | | | | | | |

Final statement:

This test report, measurements made by TRC are traceable to the NIST.

Conducted Test Placement:

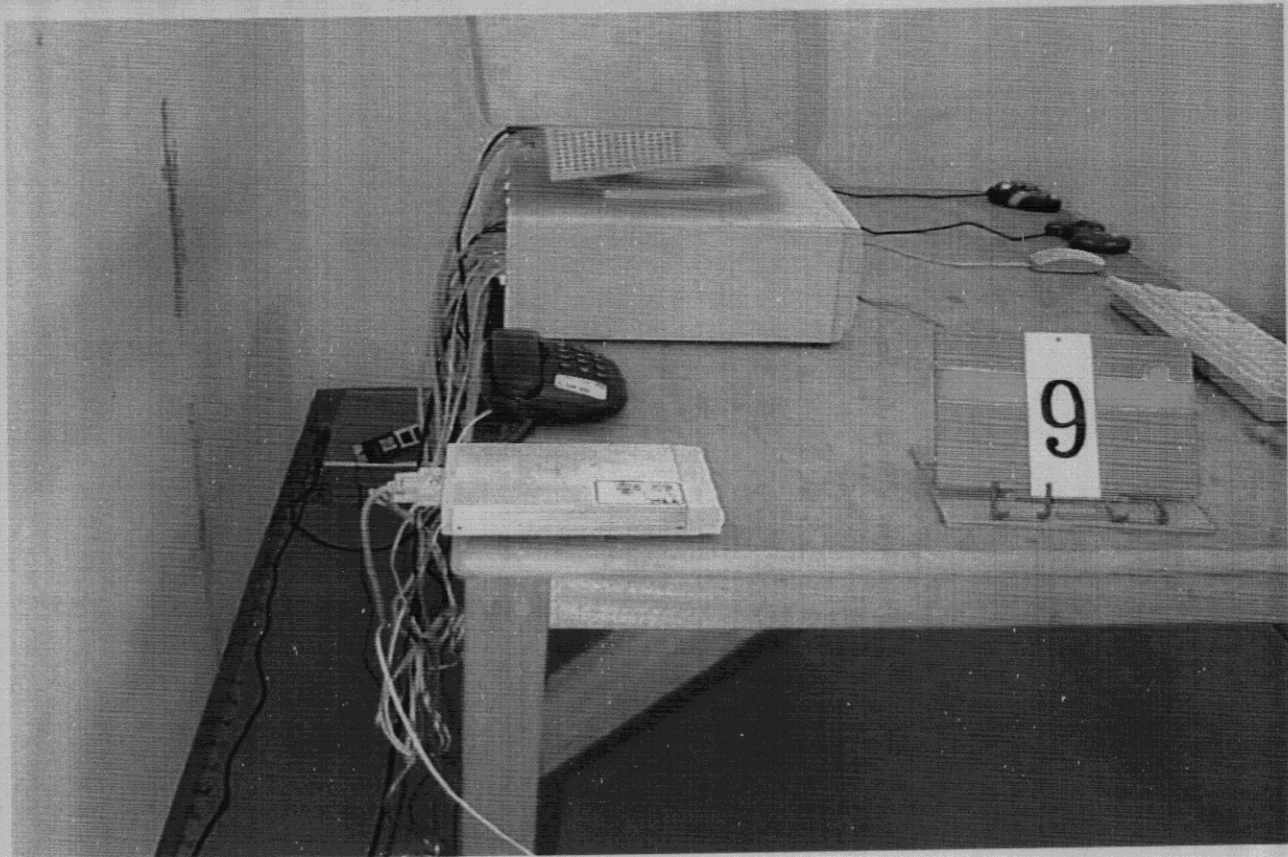

Radiated Test Placement: (Photographs)

