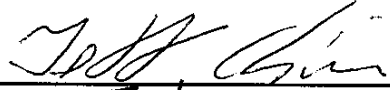



EXHIBIT B

Test Report

Report No.	C0915425
Specifications	FCC Part 15, Class B
Test Method	ANSI C63.4 1992
Applicant address	16F, No. 75 Hsin Tai Wu RD., Sec. 1 Bldg #A Hsi-Chih, Taipei Hsien, Taiwan
Applicant Items tested	CIS TECHNOLOGY INC. 8 Port Switch Ethernet Hub
Model No.	WS-SH08 (Sample # C09425)
Results	Compliance (As detailed within this report)
Sample received data	06/17/1999 (month / day / year)
Prepared by	 project engineer
Authorized by	 General Manager (Frank Tsai)
Issue date	12, 27, 99 (month / day / year)
Modifications	None
Tested by	Training Research Co., Ltd.
Office at	2, Lane 194, Huan-Ho Street, Hsichih, Taipei Hsien 221, Taiwan
Open site at	No. 15, Lane 530, Pa-Lian RD., Sec. 1, Hsichih City, Taipei Hsien, Taiwan, R.O.C.

Conditions of issue:

- (1) **This test report shall not be reproduced except in full, without written approval of TRC. And the test result contained within this report only relate to the sample submitted for testing.**
- (2) **This report must not be used by the client to claim product endorsement by NVLAP or any agency of U.S. Government.**

FCC ID : LAOSH08

Report No.: C0915425, 8 Port Switch Ethernet Hub, FCC Class B

Test date: 06/16/99, Training Research Co., Ltd., TEL: 886-2-26935155, Fax: 886-2-26934440

Contents

Chapter 1 Introduction

Description of EUT	3
Configuration of Test Setup	4
List of Support Equipment	5

Chapter 2 Conducted Emission Test

Test Condition and Setup	7
Conducted Test Placement	8

Chapter 3 Radiated Emission Test

Test Condition and Setup	9
Radiated Test Placement	10

Appendix A:

Conducted test result.....	11
----------------------------	----

Appendix B:

Radiated test result.....	12
---------------------------	----

Chapter 1 Introduction

Description of EUT:

HUB is a data transmission / receiver facility. It is connected to Lan card installed in the PC or compatible computer and makes your data equipment available to transmit / receive data via the EUT. During testing, the EUT was operated at Tx or Rx mode for each emission measured. This is done in order to insure that maximum emission levels were attained.

Connections of EUT:

- (1) The power jack of EUT is connected with the AC power source via a power adapter.
- (2) UTP 1 port is connected with a Lan card installed in the nearby PC.
- (3) UTP 8 port is connected with another Lan card installed in another PC located remotely.
- (4) The other UTP ports are terminated.

Test method:

The testing program is provided by the applicant.

Pretest was found that the emission of operating mode is worse than standby mode. So, The final test is made at the operating mode.

During pretest, there were three modes testing: 10 x 10MHz, 10 x 100MHz, 100 x 100MHz.

During testing, the EUT was operated at “transmitting” and “receiving” mode simultaneously.

The test placement as the photographs showed is the worst case emission placed. (If the emission is close to the ambient, the resolution BW and view resolution will be reduced and the data will be recorded by detection of maximum hold peak mode.)

The testing configuration of test setup is showing in the next page.

Configuration of test setup

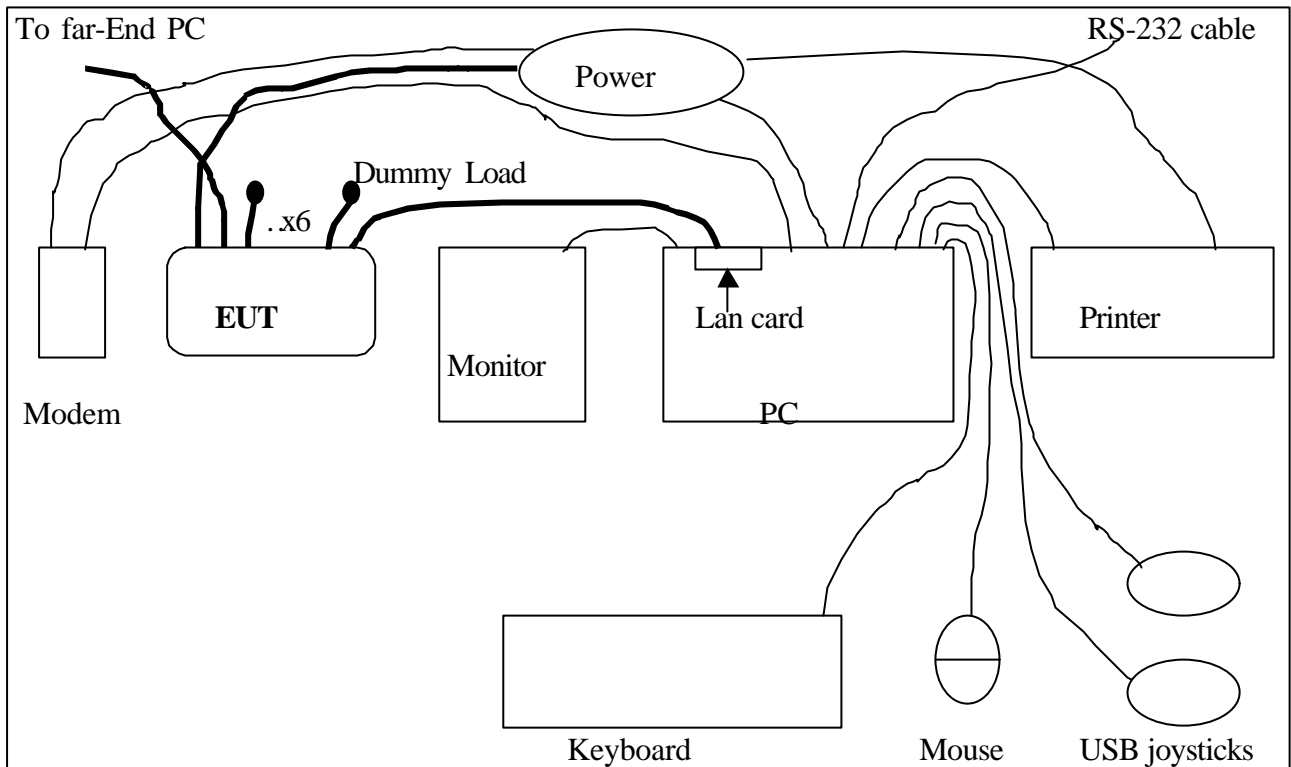

Connections:

PC:

- *Serial A port --- a external modem with 76 cm shielded RS-232 cable
 - *Serial B port --- a 76 cm shielded RS232 cable
 - *Printer port --- a Printer with 1.2m length data cable
 - *Monitor port --- a monitor with 1m length data cable
 - *Keyboard port --- a Keyboard with 1m length data cable
 - *Mouse port --- a Mouse with 0.7m long of data cable
 - *USB ports --- two USB joysticks with 1.5m long, shielded, no ferrite bead data cable
- (Each port on PC is connected with suitable device)

EUT:

*UTP 1 port --- via a 1m long, non-shielded, no ferrite bead, RJ-45 cable to the RJ-45 jack of the Lan card that installed in nearby PC.

*UTP 2~7 port --- connect with a 1m long, non-shielded, no ferrite bead, RJ-45 cable that terminated with 200ohm.

*UTP 8 port --- via a 30m long, non-shielded, no ferrite bead, RJ-45 cable to another Lan card that installed in another PC located in far-end.

*Power jack --- connect with a power adapter that the power cable is 1.8m long, non-shielded, with ferrite bead.

List of support equipment

Conducted (Radiated) test:

PC : HP

Model : VE6/350 SERIES 8
Serial No. : SG91002329
FCC ID : DoC Approval
Power type : AC 100~127 / 200~240 VAC, Switching
Power cord : non-Shielded, 1.7m long, Plastic, no ferrite core

Monitor : HP

Model No. : D2821
Serial No. : TW 73512262 (TW 73147163)
FCC ID : A3KMO64
Power type : AC 110~120 / 220~240 VAC, Switching
Power cord : Non-Shielded, 3m long, no ferrite core
Data cable : Shielded, 1.8m long, with ferrite core

Keyboard : Digital

Model No. : KB-5923
Serial No. : 9S74904837 (9S74904665)
FCC ID : E8HKB-5923
Power type : By PC
Data cable : Shielded, 1.8m long, with ferrite core

Printer : HP

Model No. : C2642A
Serial No.: SG69A196GV
FCC ID : B94C2642X
Power type : 110 VAC, 60Hz
Power cord : Non-shielded, 2m long, no ferrite core
Data cable : Shielded, 1.84m long, no ferrite core (1.7m)

Modem : **ACEEX**
Model No. : XDM-56V14
FCC ID : IFAXDM-56V14
Power type : 110VAC, 60HZ/ 9VAC, 1A
Power cord : Non-shielded, 1.9m long, no ferrite cord
Data cable : RS232, Shielded, 1.2m long, no ferrite core
RJ11C x 2, 7' long non-shielded, no ferrite core

Mouse : **Hewlett Packard Mouse**
Model No. : C3751B
Serial No. : LCA52707170
FCC ID : DZL210582
Power type : Powered by PC
Power Cable : Non – Shielded. 5.5' long, Plastic hoods, No ferrite bead

Joystick : **Padix**
Model : QF-3U, QF-305U, QF-606U, QF-707U (DoC Approval)
Power Type : By PC

Lan Card : **DELTA**
Model No. : AEF380-TX
Serial No. : N/A
Power Type : Powered by PC
Data Cable : UTP, 7', Plastic RJ-45 hoods, No ferrite bead.

Chapter 2 Conducted emission test

Test condition and setup:

All the equipment is placed and setup according to the ANSI C63.4-1992. The EUT is assembled on a wooden table that is 80 cm high, is placed 40 cm from the back-wall that is a vertical conducting plane. One LISN is for EUT, the other LISN is for support equipment. They are all placed on the conductive ground. The EUT' s LISN connect a line switch box for selecting L1 or L2, then connect to a preamplifier and spectrum.

The spectrum scans from 450KHz to 30MHz. Conducted emission levels are detected at max. peak mode. But if the max. peak mode failed, it will be measured by CISPR' s quasi-peak detection mode.

While testing, there is the worst-emission plot printed at peak detection mode, and there are more than 6 highest emissions relative to limit recorded. The plot is kept as the original data, not included in test report.

List of test Instrument:

<u>Instrument Name</u>	<u>Model No.</u>	<u>Brand</u>	<u>Serial No.</u>	<u>Calibration Date</u>	
				<u>Last time</u>	<u>Next time</u>
Spectrum analyzer	8594EM	H P	3710A00279	01/07/99	01/07/00
LISN (EUT)	3825/2	EMCO	9411-2284	05/20/99	05/20/00
LISN (Support E.)	AC3-001	TRC	-----	05/20/99	05/20/00
Preamplifier	AC3-002	TRC	-----	05/20/99	05/20/00
Line switch box	AC3-003	TRC	-----	05/20/99	05/20/00

The level of confidence of 95%, the uncertainty of measurement of conducted emission is ± 2.4 dB.

Test Result: Pass (Appendix A)

Conducted Test Placement:



Report No.: C0915425, 8 Port Switch Ethernet Hub, FCC Class B

Test date: 06/16/99, Training Research Co., Ltd., TEL: 886-2-26935155, Fax: 886-2-26934440

Chapter 3 Radiated emission test

Test condition and setup:

Pretest: Prior to the final test (OATS test), the EUT is placed in a anechoic chamber and scan from 30MHz to 1GHz. This is done to ensure the radiation exactly emits form the EUT.

Final test: Final radiation measurements are made on a **3 - meter**, open-field test site. The EUT is placed on a nonconductive table that is 0.8m height, the top surface is 1.0 x 1.5 meter. The placement is according to ANSI C63.4-1992.

The spectrum is examined from 30 MHz to 1000 MHz measured by HP spectrum.

The EMCO whole range Antenna is used to measure frequency from 30 MHz to 1GHz. The final test is used the spectrum HP 8594EM.

Measure more than six top marked frequencies generated form pretest by computer step by step at each frequency. The EUT is rotated 360 degrees, and antenna is raised and lowered from 1 to 4 meters to find the maximum emission levels. The antenna is used with both horizontal and vertical polarization.

Appropriated preamplifier that is made by TRC is used for improving sensitivity and precaution is taken to avoid overloading. The spectrum analyzer' s 6dB bandwidth is set to 120 KHz, and the EUT is measured at quasi-peak mode.

If the emission is close to the frequency band of ambient, the data will be rechecked by the tester and the corrected data will be written in the test data sheet. If the emission is just within the ambient, the data from anechoic chamber will be taken as the final data.

List of test Instrument:

Calibration Date

<u>Instrument Name</u>	<u>Model No.</u>	<u>Brand</u>	<u>Serial No.</u>	<u>Last</u>	<u>Next</u>
Spectrum analyzer	8594EM	H P	3619A00198	11/17/98	11/17/99
RF Pre-selector	AC4-001	TRC	-----	05/20/99	05/20/00
Antenna (30M-2G Hz)	3141	EMCO	9711-1076	12/17/98	12/17/99
Open test side (Antenna, Amplify, cable calibrated together)				05/20/99	05/20/00

The level of confidence of 95%, the uncertainty of measurement of radiated emission is ± 4.96 dB.

Test Result: Pass (Appendix B)

Radiated Test Placement: (Photographs)



Appendix A

Conducted Emission Test Result: (10 X 10 MHz)

Testing room: Temperature : 28 ° C Humidity : 45 % RH

Line 1

FREQUENCY (KHz)	READING AMPLITUDE			LIMIT		MARGIN (dB)
	Peak (dBµV/m)	Quasi-peak (dBµV/m)	Average (dBµV/m)	Quasi-Peak (dBµV/m)	Average (dBµV/m)	
579	29.53	***.**	***.**	48.00	***.**	-18.47
684	26.40	***.**	***.**	48.00	***.**	-21.60
744	26.36	***.**	***.**	48.00	***.**	-21.64
839	27.90	***.**	***.**	48.00	***.**	-20.10
898	28.06	***.**	***.**	48.00	***.**	-19.94
947	27.26	***.**	***.**	48.00	***.**	-20.74
1055	31.03	***.**	***.**	48.00	***.**	-16.97
6220	36.36	***.**	***.**	48.00	***.**	-11.64
8750	27.95	***.**	***.**	48.00	***.**	-20.05
20000	29.08	***.**	***.**	48.00	***.**	-18.92

Line 2

FREQUENCY (KHz)	READING AMPLITUDE			LIMIT		MARGIN (dB)
	Peak (dBµV/m)	Quasi-peak (dBµV/m)	Average (dBµV/m)	Quasi-Peak (dBµV/m)	Average (dBµV/m)	
579	33.19	***.**	***.**	48.00	***.**	-14.81
684	33.48	***.**	***.**	48.00	***.**	-14.52
734	30.22	***.**	***.**	48.00	***.**	-17.78
783	31.18	***.**	***.**	48.00	***.**	-16.82
839	29.95	***.**	***.**	48.00	***.**	-18.05
886	31.86	***.**	***.**	48.00	***.**	-16.14
941	35.11	***.**	***.**	48.00	***.**	-12.89
6260	34.43	***.**	***.**	48.00	***.**	-13.57
11260	28.19	***.**	***.**	48.00	***.**	-19.81
23650	28.28	***.**	***.**	48.00	***.**	-19.72

Conducted Emission Test Result: (10 X 100 MHz)

Testing room: Temperature : 28 ° C Humidity : 45 % RH

Line 1

FREQUENCY (KHz)	READING AMPLITUDE			LIMIT		MARGIN (dB)
	Peak (dBµV/m)	Quasi-peak (dBµV/m)	Average (dBµV/m)	Quasi-Peak (dBµV/m)	Average (dBµV/m)	
1149	32.03	***.**	***.**	48.00	***.**	-15.97
16260	36.33	***.**	***.**	48.00	***.**	-11.67
16910	31.82	***.**	***.**	48.00	***.**	-16.18
17700	31.24	***.**	***.**	48.00	***.**	-16.76
18210	36.49	***.**	***.**	48.00	***.**	-11.51
18980	33.24	***.**	***.**	48.00	***.**	-14.76
19750	34.76	***.**	***.**	48.00	***.**	-13.24
20260	32.88	***.**	***.**	48.00	***.**	-15.12
21560	31.69	***.**	***.**	48.00	***.**	-16.31
23050	31.65	***.**	***.**	48.00	***.**	-16.35

Line 2

FREQUENCY (KHz)	READING AMPLITUDE			LIMIT		MARGIN (dB)
	Peak (dBµV/m)	Quasi-peak (dBµV/m)	Average (dBµV/m)	Quasi-Peak (dBµV/m)	Average (dBµV/m)	
778	34.11	***.**	***.**	48.00	***.**	-13.89
886	33.99	***.**	***.**	48.00	***.**	-14.01
935	34.69	***.**	***.**	48.00	***.**	-13.31
16260	37.12	***.**	***.**	48.00	***.**	-10.88
17700	36.62	***.**	***.**	48.00	***.**	-11.38
18210	38.34	***.**	***.**	48.00	***.**	-9.66
18850	35.70	***.**	***.**	48.00	***.**	-12.30
19750	33.70	***.**	***.**	48.00	***.**	-14.30
21560	35.14	***.**	***.**	48.00	***.**	-12.86
23050	35.24	***.**	***.**	48.00	***.**	-12.76

Conducted Emission Test Result: (100 X 100 MHz)

Testing room: Temperature : 28 ° C Humidity : 45 % RH

Line 1

FREQUENCY (KHz)	READING AMPLITUDE			LIMIT		MARGIN (dB)
	Peak (dBμV/m)	Quasi-peak (dBμV/m)	Average (dBμV/m)	Quasi-Peak (dBμV/m)	Average (dBμV/m)	
527	33.58	***.**	***.**	48.00	***.**	-14.42
688	32.91	***.**	***.**	48.00	***.**	-15.09
16260	35.43	***.**	***.**	48.00	***.**	-12.57
17020	33.97	***.**	***.**	48.00	***.**	-14.03
17700	38.05	***.**	***.**	48.00	***.**	-9.95
18340	37.31	***.**	***.**	48.00	***.**	-10.69
18980	35.38	***.**	***.**	48.00	***.**	-12.62
19750	37.20	***.**	***.**	48.00	***.**	-10.80
20260	33.46	***.**	***.**	48.00	***.**	-14.54
23050	37.90	***.**	***.**	48.00	***.**	-10.10

Line 2

FREQUENCY (KHz)	READING AMPLITUDE			LIMIT		MARGIN (dB)
	Peak (dBμV/m)	Quasi-peak (dBμV/m)	Average (dBμV/m)	Quasi-Peak (dBμV/m)	Average (dBμV/m)	
793	35.57	***.**	***.**	48.00	***.**	-12.43
16260	38.92	***.**	***.**	48.00	***.**	-9.08
17700	39.89	***.**	***.**	48.00	***.**	-8.11
18210	38.41	***.**	***.**	48.00	***.**	-9.59
18850	35.61	***.**	***.**	48.00	***.**	-12.39
19750	37.72	***.**	***.**	48.00	***.**	-10.28
20260	35.64	***.**	***.**	48.00	***.**	-12.36
21560	34.63	***.**	***.**	48.00	***.**	-13.37
22460	34.78	***.**	***.**	48.00	***.**	-13.22
23050	36.22	***.**	***.**	48.00	***.**	-11.78

Appendix B

Radiated Emission Test Result: (Horizontal) (10 X 100 MHz)

Test Conditions:

Testing room : Temperature : 26 ° C Humidity : 32 % RH
 Testing site : Temperature : 26 ° C Humidity : 45 % RH

Frequency	Reading Amplitude	Ant. Heigh	Table	Correction Factors	Corrected Amplitude	Class B limit	Margin
MHz	dBµV	m	degree	dB/m	dBµV/m	dBµV/m	dB

350.000	45.86	0.99	98	-19.58	26.28	46.00	-19.72
375.000	56.51	2.51	283	-18.73	37.78	46.00	-8.22
400.010	57.18	0.99	131	-17.95	39.23	46.00	-6.77

Note:

1. Margin = Amplitude - limit, if margin is minus means under limit.
 2. Corrected Amplitude = Reading Amplitude + Correction Factors
 3. Correction factor = Antenna factor + (Cable Loss - Amplitude gain)
- (For example: 30MHz correction factor = 15.5 + (-15.26) = 0.24 dB/m)

Radiated Emission Test Result: (Vertical) (10 X 100 MHz)

Frequency	Reading Amplitude	Ant. Heigh	Table	Correction Factors	Corrected Amplitude	Class B limit	Margin
MHz	dBµV	m	degree	dB/m	dBµV/m	dBµV/m	dB

32.020	52.72	0.99	29	-23.40	29.32	40.00	-10.68
47.810	55.48	0.98	31	-21.95	33.53	40.00	-6.47
48.010	41.77	0.99	12	-21.94	19.83	40.00	-20.17
52.010	46.24	0.99	16	-22.61	23.63	40.00	-16.37
77.210	60.91	4.00	140	-24.17	36.74	40.00	-3.26
106.750	56.00	0.99	283	-23.62	32.38	43.50	-11.12
125.000	52.60	4.00	276	-21.89	30.71	43.50	-12.79

Final statement:

This test report, measurements made by TRC are traceable to the NIST.

