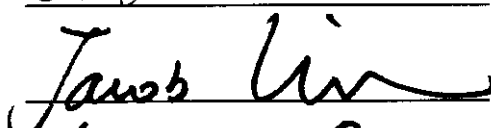
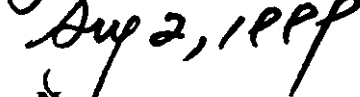

***EXHIBIT B***

***Test Report***

Report No.	C0915580	
Specifications	FCC Part 15, Class B	
Test Method	ANSI C63.4 1992	
Applicant address	16F, No. 75 Hsin Tai Wu RD., Sec. 1 Bldg #A Hsi-Chih, Taipei Hsien, Taiwan	
Applicant Items tested	CIS TECHNOLOGY INC. 5 Port Switch Ethernet Hub	
Model No.	WS-SH05 (Sample # C09580)	
Results	<b>Compliance</b> (As detailed within this report)	
Sample received data	07/23/1999 (month / day / year)	
Prepared by		project engineer
Authorized by		Vice General Manager (Jacob Lin)
Issue date	 Aug 2, 1999	(month / day / year)
Modifications	None	
Tested by	Training Research Co., Ltd.	
Office and Open site at	No. 15, Lane 530, Pa-Lian RD., Sec. 1, Hsichih City, Taipei Hsien, Taiwan, R.O.C.	

**Conditions of issue:**

- (1) **This test report shall not be reproduced except in full, without written approval of TRC. And the test result contained within this report only relate to the sample submitted for testing.**
- (2) **This report must not be used by the client to claim product endorsement by NVLAP or any agency of U.S. Government.**

★ FCC ID: L40SH05

# Contents

## Chapter 1 Introduction

Description of EUT.....	3
Configuration of Test Setup.....	5
List of Support Equipment.....	6

## Chapter 2 Conducted Emission Test

Test Condition and Setup.....	8
Conducted Test Placement.....	9

## Chapter 3 Radiated Emission Test

Test Condition and Setup.....	10
Radiated Test Placement.....	11

## Appendix A:

Conducted test result .....	12
-----------------------------	----

## Appendix B:

Radiated test result .....	15
----------------------------	----

## ***Chapter 1 Introduction***

### ***Description of EUT:***

HUB is a data transmission / receiver facility. It was connected to Lan card installed in the PC or compatible computer and makes your data equipment available to transmit / receive data via the EUT. During testing the EUT was operated at Tx or Rx mode for each emission measured. This was done in order to insure that maximum emission levels were attained.

### ***Connections of EUT:***

- (1) The power jack of EUT was connected with the AC power source via a power adapter.
- (2) UTP 1 port was connected with a Lan card installed in the nearby PC.
- (3) UTP 5 port was connected with another Lan card installed in another PC located remotely.
- (4) The other UTP ports were terminated.

### ***Test method:***

Pretest was found that the emission of operating mode is worse than standby mode. So, The final test is made at the operating mode.

During pretest, there were three modes testing: 10 x 10MHz, 10 x 100MHz, 100 x 100MHz.

During testing, the EUT was operated at "transmitting" and "receiving" mode simultaneously.

The test placement as the photographs showed is the worst case emission placed. (If the emission is close to the ambient, the resolution BW and view resolution will be reduced and the data will be recorded by detection of maximum hold peak mode.)

***The testing configuration of test setup is showing in the next page.***

### Configuration of test setup

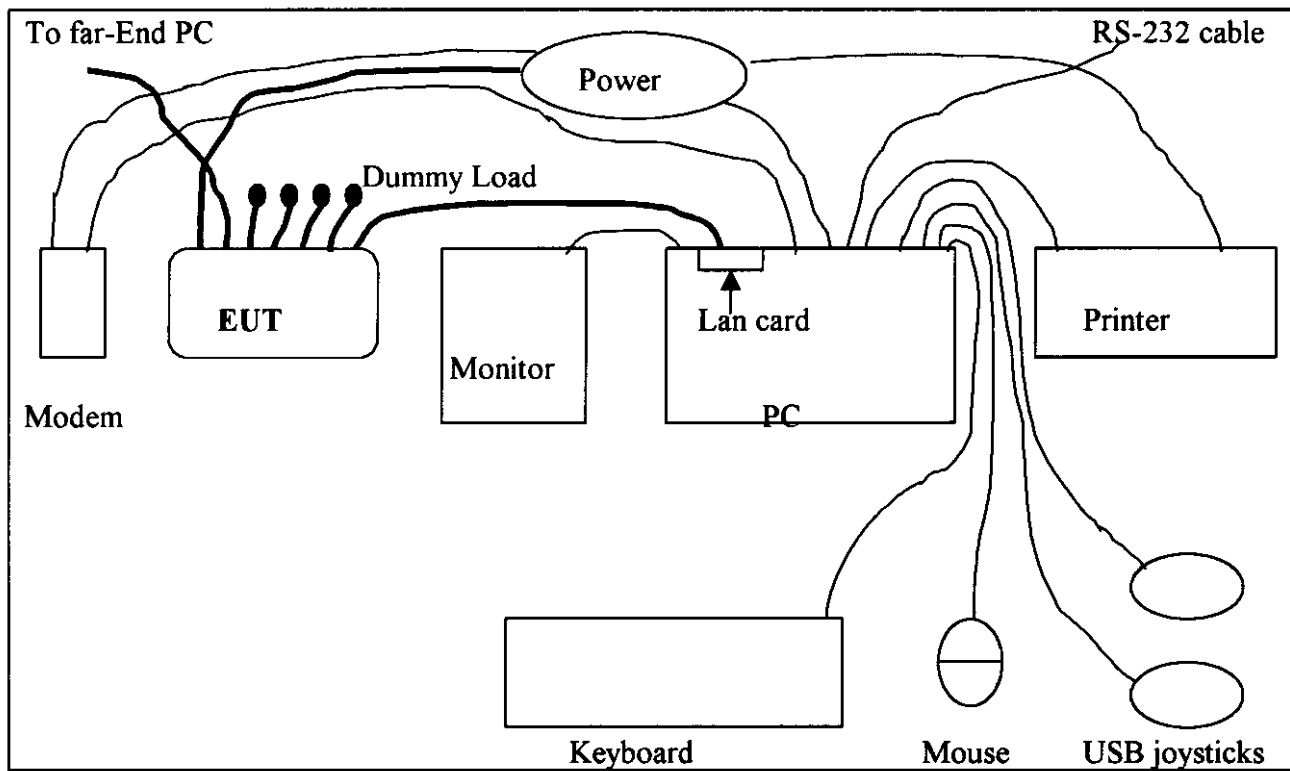

### Connections:

#### PC:

- \*Serial A port --- a external modem with 76 cm shielded RS-232 cable
- \*Serial B port --- a 76 cm shielded RS232 cable
- \*Printer port --- a Printer with 1.2m length data cable
- \*Monitor port --- a monitor with 1m length data cable
- \*Keyboard port --- a Keyboard with 1m length data cable
- \*Mouse port --- a Mouse with 0.7m long of data cable
- \*USB ports --- two USB joysticks with 1.5m long, shielded, no ferrite bead data cable  
(Each port on PC is connected with suitable device)

#### Lan Card

- \*RJ-45 jack --- via a 3m long, non-shielded, no ferrite bead, RJ-45 cable to EUT.

***EUT:***

- \*UTP 1 port --- via a 1m long, non-shielded, no ferrite bead, RJ-45 cable to the RJ-45 jack of the Lan card that installed in PC.
- \*UTP 2~4 port --- connect with a 1m long, non-shielded, no ferrite bead, RJ-45 cable that terminated with 200ohm.
- \*UTP 5 port --- via a 30m long, non-shielded, no ferrite bead, RJ-45 cable to another Lan card that installed in another PC located in far-end.
- \*Power jack --- connect with a power adapter that the power cable is 1.8m long, non-shielded, with ferrite bead.

**List of support equipment**

**Conducted (Radiated) test:**

**PC** : **HP**  
Model : VE6/350 SERIES 8  
Serial No. : SG91002329  
FCC ID : DoC Approval  
Power type : AC 100~127 / 200~240 VAC, Switching  
Power cord : non-Shielded, 1.7m long, Plastic, no ferrite core

**Monitor** : **HP**  
Model No. : D2821  
Serial No. : TW 73512262 (TW 73147163)  
FCC ID : A3KMO64  
Power type : AC 110~120 / 220~240 VAC, Switching  
Power cord : Non-Shielded, 3m long, no ferrite core  
Data cable : Shielded, 1.8m long, with ferrite core

**Keyboard** : **Digital**  
Model No. : KB-5923  
Serial No. : 9S74904837 (9S74904665)  
FCC ID : E8HKB-5923  
Power type : By PC  
Data cable : Shielded, 1.8m long, with ferrite core

**Printer** : **HP**  
Model No. : C2642A  
Serial No. : SG69A196GV  
FCC ID : B94C2642X  
Power type : 110 VAC, 60Hz  
Power cord : Non-shielded, 2m long, no ferrite core  
Data cable : Shielded, 1.84m long, no ferrite core (1.7m)

**Modem** : **ACEEX**  
Model No. : XDM-56V14  
FCC ID : IFAXDM-56V14  
Power type : 110VAC, 60HZ/ 9VAC, 1A  
Power cord : Non-shielded, 1.9m long, no ferrite cord  
Data cable : RS232, Shielded, 1.2m long, no ferrite core  
RJ11C x 2, 7' long non-shielded, no ferrite core

**Mouse** : **Hewlett Packard Mouse**  
Model No. : C3751B  
Serial No. : LCA52707170  
FCC ID : DZL210582  
Power type : Powered by PC  
Power Cable : Non – Shielded. 5.5' long, Plastic hoods, No ferrite bead

**Joystick** : **Padix**  
Model : QF-3U, QF-305U, QF-606U, QF-707U ( DoC Approval )  
Power Type : By PC

**Lan Card** : **DELTA**  
Model No. : AEF380-TX  
Serial No. : N/A  
Power Type : Powered by PC  
Data Cable : UTP, 7', Plastic RJ-45 hoods, No ferrite bead.



## **Chapter 2 Conducted emission test**

### **Test condition and setup:**

All the equipment is placed and setup according to the ANSI C63.4-1992.

The EUT is assembled on a wooden table that is 80 cm high, is placed 40 cm from the back-wall that is a vertical conducting plane. One LISN is for EUT, the other LISN is for support equipment. They are all placed on the conductive ground. The EUT's LISN connect a line switch box for selecting L1 or L2, then connect to a preamplifier and spectrum.

The spectrum scans from 450KHz to 30MHz. Conducted emission levels are detected at max. peak mode. But if the max. peak mode failed, it will be measured by CISPR's quasi-peak detection mode.

While testing, there is the worst-emission plot printed at peak detection mode, and there are more than 6 highest emissions relative to limit recorded. The plot is kept as the original data, not included in test report.

### **List of test Instrument:**

<u>Instrument Name</u>	<u>Model No.</u>	<u>Brand</u>	<u>Serial No.</u>	<u>Calibration Date</u>	
				<u>Last time</u>	<u>Next time</u>
Spectrum analyzer	8594EM	H P	3710A00279	01/07/99	01/07/00
LISN (EUT)	3825/2	EMCO	9411-2284	05/20/99	05/20/00
LISN (Support E.)	AC3-001	TRC	-----	05/20/99	05/20/00
Preamplifier	AC3-002	TRC	-----	05/20/99	05/20/00
Line switch box	AC3-003	TRC	-----	05/20/99	05/20/00

The level of confidence of 95%, the uncertainty of measurement of conducted emission is  $\pm 2.4$  dB.

**Test Result: Pass (Appendix A)**

### *Chapter 3 Radiated emission test*

***Test condition and setup:***

***Pretest:*** Prior to the final test (OATS test), the EUT is placed in a anechoic chamber and scan from 30MHz to 1GHz. This is done to ensure the radiation exactly emits form the EUT.

***Final test:*** Final radiation measurements are made on a **3 - meter, open-field** test site. The EUT is placed on a nonconductive table that is 0.8m height, the top surface is 1.0 x 1.5 meter. The placement is according to ANSI C63.4-1992.

The spectrum is examined from 30 MHz to 1000 MHz measured by HP spectrum.

The EMCO whole range Antenna is used to measure frequency from 30 MHz to 1GHz. The final test is used the spectrum HP 8594EM.

Measure more than six top marked frequencies generated form pretest by computer step by step at each frequency. The EUT is rotated 360 degrees, and antenna is raised and lowered from 1 to 4 meters to find the maximum emission levels. The antenna is used with both horizontal and vertical polarization.

Appropriated preamplifier which is made by TRC is used for improving sensitivity and precautions is taken to avoid overloading. The spectrum analyzer's 6dB bandwidth is set to 120 KHz, and the EUT is measured at quasi-peak mode.

If the emission is close to the frequency band of ambient, the data will be rechecked by the tester and the corrected data will be written in the test data sheet. If the emission is just within the ambient, the data from anechoic chamber will be taken as the final data.

***List of test Instrument:***

**Calibration Date**

<u>Instrument Name</u>	<u>Model No.</u>	<u>Brand</u>	<u>Serial No.</u>	<u>Last</u>	<u>Next</u>
Spectrum analyzer	8594EM	H P	3619A00198	11/17/98	11/17/99
RF Pre-selector	AC4-001	TRC	-----	05/20/99	05/20/00
Antenna (30M-2G Hz)	3141	EMCO	9711-1076	12/17/98	12/17/99
Open test side (Antenna, Amplify, cable calibrated together)				05/20/99	05/20/00

The level of confidence of 95%, the uncertainty of measurement of radiated emission is  $\pm 4.96$  dB.

***Test Result: Pass (Appendix B)***

**Appendix A**

**Conducted Emission Test Result: ( 10 X 10 MHz )**

Testing room: Temperature : 26 ° C Humidity : 63 % RH

**Line 1**

FREQUENCY ( KHz )	READING AMPLITUDE			LIMIT		MARGIN ( dB )
	Peak (dBμV/m)	Quasi-peak (dBμV/m)	Average (dBμV/m)	Quasi-Peak (dBμV/m)	Average (dBμV/m)	
152	33.92	*** **	*** **	65.94	55.94	-22.02
251	35.98	*** **	*** **	63.11	53.11	-17.13
257	39.07	*** **	*** **	62.94	52.94	-13.87
291	29.76	*** **	*** **	61.97	51.97	-22.21
301	35.38	*** **	*** **	61.69	51.69	-16.31
306	39.74	*** **	*** **	61.54	51.54	-11.80
320	35.62	*** **	*** **	61.14	50.00	-14.38
327	40.23	*** **	*** **	60.94	50.94	-10.71
342	31.89	*** **	*** **	60.51	50.51	-18.62
352	30.65	*** **	*** **	60.23	50.23	-19.58

**Line 2**

FREQUENCY ( KHz )	READING AMPLITUDE			LIMIT		MARGIN ( dB )
	Peak (dBμV/m)	Quasi-peak (dBμV/m)	Average (dBμV/m)	Quasi-Peak (dBμV/m)	Average (dBμV/m)	
152	33.20	*** **	*** **	65.94	55.94	-22.74
156	33.74	*** **	*** **	65.83	55.83	-22.09
259	37.37	*** **	*** **	62.89	52.89	-15.52
270	30.75	*** **	*** **	62.57	52.57	-21.82
280	30.49	*** **	*** **	62.29	52.29	-21.80
291	31.91	*** **	*** **	61.97	51.97	-20.06
304	40.83	*** **	*** **	61.60	51.60	-10.77
322	37.90	*** **	*** **	61.09	51.09	-13.19
342	30.45	*** **	*** **	60.51	50.51	-20.06
354	29.28	*** **	*** **	60.17	50.17	-20.89

\* The reading amplitudes are all under average limit.

**Conducted Emission Test Result: ( 10 X 100 MHz )**

Testing room: Temperature : 26 ° C Humidity : 63 % RH

**Line 1**

FREQUENCY ( KHz )	READING AMPLITUDE			LIMIT		MARGIN ( dB )
	Peak (dBμV/m)	Quasi-peak (dBμV/m)	Average (dBμV/m)	Quasi-Peak (dBμV/m)	Average (dBμV/m)	
153	34.90	*** **	*** **	65.91	55.91	-21.01
248	32.65	*** **	*** **	63.20	53.20	-20.55
256	38.35	*** **	*** **	62.97	52.97	-14.62
289	32.03	*** **	*** **	62.03	52.03	-20.00
301	40.07	*** **	*** **	61.69	51.69	-11.62
306	40.10	*** **	*** **	61.54	51.54	-11.44
322	37.89	*** **	*** **	61.09	51.09	-13.20
338	32.11	*** **	*** **	60.63	50.63	-18.52
349	32.29	*** **	*** **	60.31	50.31	-18.02
16260	26.77	*** **	*** **	60.00	50.00	-23.23

**Line 2**

FREQUENCY ( KHz )	READING AMPLITUDE			LIMIT		MARGIN ( dB )
	Peak (dBμV/m)	Quasi-peak (dBμV/m)	Average (dBμV/m)	Quasi-Peak (dBμV/m)	Average (dBμV/m)	
156	32.91	*** **	*** **	65.83	55.83	-22.92
219	31.67	*** **	*** **	64.03	54.03	-22.36
254	37.36	*** **	*** **	63.03	53.03	-15.67
272	30.94	*** **	*** **	62.51	52.51	-21.57
291	30.34	*** **	*** **	61.97	51.97	-21.63
306	40.24	*** **	*** **	61.54	51.54	-11.30
318	34.59	*** **	*** **	61.20	51.20	-16.61
327	35.88	*** **	*** **	60.94	50.94	-15.06
338	31.79	*** **	*** **	60.63	50.63	-18.84
349	30.86	*** **	*** **	60.31	50.31	-19.45

\* The reading amplitudes are all under average limit.

**Conducted Emission Test Result: ( 100 X 100 MHz )**

Testing room: Temperature : 26 ° C Humidity : 63 % RH

**Line 1**

FREQUENCY ( KHz )	READING AMPLITUDE			LIMIT		MARGIN ( dB )
	Peak (dBµV/m)	Quasi-peak (dBµV/m)	Average (dBµV/m)	Quasi-Peak (dBµV/m)	Average (dBµV/m)	
156	33.13	*** **	*** **	65.83	55.83	-22.70
256	38.51	*** **	*** **	62.97	52.97	-14.46
261	35.75	*** **	*** **	62.83	52.83	-17.08
270	31.64	*** **	*** **	62.57	52.57	-20.93
282	29.11	*** **	*** **	62.23	52.23	-23.12
306	41.31	*** **	*** **	61.54	51.54	-10.23
324	36.23	*** **	*** **	61.03	51.03	-14.80
338	31.82	*** **	*** **	60.63	50.63	-18.81
352	30.32	*** **	*** **	60.23	50.23	-19.91
16150	28.49	*** **	*** **	60.00	50.00	-21.51

**Line 2**

FREQUENCY ( KHz )	READING AMPLITUDE			LIMIT		MARGIN ( dB )
	Peak (dBµV/m)	Quasi-peak (dBµV/m)	Average (dBµV/m)	Quasi-Peak (dBµV/m)	Average (dBµV/m)	
154	35.93	*** **	*** **	65.89	55.89	-19.96
254	38.22	*** **	*** **	63.03	53.03	-14.81
269	31.78	*** **	*** **	62.60	52.60	-20.82
291	31.88	*** **	*** **	61.97	51.97	-20.09
299	37.59	*** **	*** **	61.74	51.74	-14.15
306	41.04	*** **	*** **	61.54	51.54	-10.50
322	39.60	*** **	*** **	61.09	51.09	-11.49
331	35.23	*** **	*** **	60.83	50.83	-15.60
338	32.02	*** **	*** **	60.63	50.63	-18.61
354	28.43	*** **	*** **	60.17	50.17	-21.74

\* The reading amplitudes are all under average limit.

**Appendix B**

**Radiated Emission Test Result: (Horizontal) ( 100 X 100 MHz )**

Test Conditions:

Testing room : Temperature : 29 ° C      Humidity : 36 % RH  
 Testing site : Temperature : 30 ° C      Humidity : 49 % RH

Frequency	Reading Amplitude	Ant. Height	Table	Correction Factors	Corrected Amplitude	Class B limit	Margin
MHz	dBµV	m	degree	dB/m	dBµV/m	dBµV/m	dB

47.800	43.97	2.51	16	-21.95	22.02	30.00	-7.98
225.000	51.55	4.00	120	-23.95	27.60	30.00	-2.40
415.000	48.42	2.52	50	-17.46	30.96	37.00	-6.04
500.000	48.31	2.51	165	-14.42	33.89	37.00	-3.11
581.000	46.56	0.99	275	-17.03	29.53	37.00	-7.47
***							

Note:

1. Margin = Amplitude - limit, if margin is minus means under limit.
  2. Corrected Amplitude = Reading Amplitude + Correction Factors
  3. Correction factor = Antenna factor + ( Cable Loss - Amplitude gain)
- (For example: 30MHz correction factor = 15.5 + (-15.26) = 0.24 dB/m)

**Radiated Emission Test Result: (Vertical) ( 100 X 100 MHz )**

Frequency	Reading Amplitude	Ant. Height	Table	Correction Factors	Corrected Amplitude	Class B limit	Margin
MHz	dBμV	m	degree	dB/m	dBμV/m	dBμV/m	dB

43.770	46.96	0.99	308	-22.16	24.80	30.00	-5.20
125.000	49.31	4.02	86	-21.89	27.42	30.00	-2.58
200.000	50.44	0.99	41	-24.56	25.88	30.00	-4.12
225.000	50.49	0.99	305	-23.95	26.54	30.00	-3.46
250.000	53.00	0.99	246	-22.68	30.32	37.00	-6.68
332.000	54.78	0.99	312	-20.03	34.75	37.00	-2.25
***							

**Final statement:**

**This test report, measurements made by TRC are traceable to the NIST.**