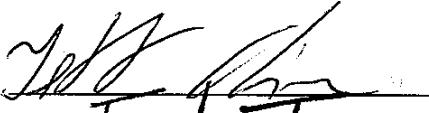
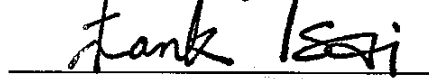

EXHIBIT B

Test Report

Report No.	C0915855
Specifications	FCC Part 15.109(g), Class B
Test Method	ANSI C63.4 1992
Applicant Address	16F, No. 75, Hsin Tai Wu RD., Sec. 1, Bldg. #A, Hsi Chih, Taipei Hsien, 221 Taiwan
Applicant Items Tested	CIS TECHNOLOGY, INC. Auto 10/100 PCI Fast Ethernet Adapter
Model No.	WS-M400/S (Sample # C09855)
Results	Compliance (As detailed within this report)
Sample Received Date	10/08/1999 (month / day / year)
Prepared by	 Project Engineer
Authorized by	 General Manager (Frank Tsai)
Issue Date	Oct. 21, 1999 (month / day / year)
Modifications	None
Tested by	Training Research Co., Ltd.
Office at	2, Lane 194, Huan-Ho Street, Hsichih, Taipei Hsien 221, Taiwan
Open Site at	No. 15, Lane 530, Pa-Lian RD., Sec. 1, Hsichih City, Taipei Hsien, Taiwan, R.O.C.

Conditions of issue:

- (1) **This test report shall not be reproduced except in full, without written approval of TRC, And the test result contained within this report only relate to the sample submitted for testing.**
- (2) **This report must not be used by the client to claim product endorsement by NVLAP or any agency of U.S. Government.**

★ FCC ID: LAOM400S

Contents

Chapter 1 Introduction

Description of EUT	3
Configuration of Test Setup	4
List of Support Equipment	5

Chapter 2 Conducted Emission Test

Test Condition and Setup	7
Conducted Test Placement	8

Chapter 3 Radiated Emission Test

Test Condition and Setup	9
Radiated Test Placement	10

Appendix A:

Conducted test result	11
-----------------------------	----

Appendix B:

Radiated test result	12
----------------------------	----

Chapter 1 Introduction

Description of EUT:

The Auto 10/100 PCI Fast Ethernet Adapter is a data transmission / receiver facility. It is designed to install in the PC or compatible computer and makes your data equipment available to transmit / receive data via the EUT. During testing the EUT was operated at Tx or Rx mode for each emission measured. This was done in order to insure that maximum emission levels were attained.

Connections of EUT:

- (1)Put the EUT into a personal computer's PCI bus and screw it.
- (2)The UTP port of EUT is connected with another Lan card installed in another PC via a Hub located remotely.

Test method:

The testing program is provided by the applicant.

During the measurement, there are two modes tested: " 10 × 10Mbps " mode and " 100 × 100Mbps " mode.

Pretest was found that the emission of operating mode is worse than standby mode. So, The final test is made at the operating mode.

During testing, the EUT was operated at "transmitting" mode.

The test placement as the photographs showed is the worst case emission placed. (If the emission is close to the ambient, the resolution BW and view resolution will be reduced and the data will be recorded by detection of maximum hold peak mode.)

The testing configuration of test setup is showing in the next page.

Configuration of test setup

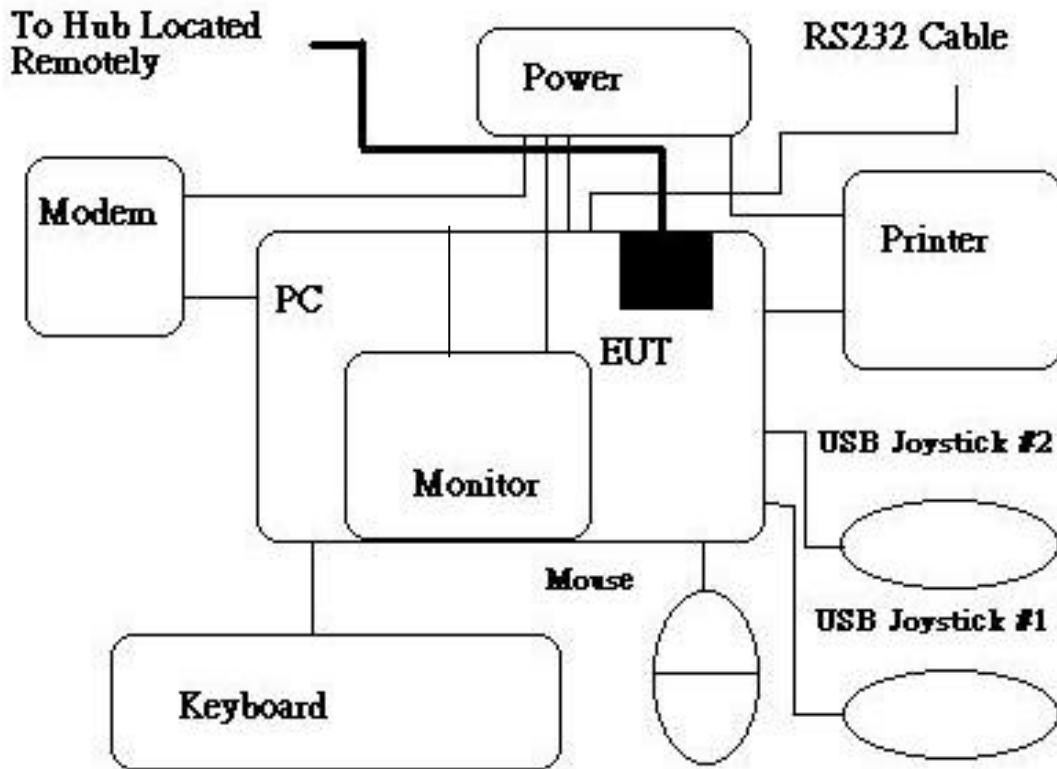

Connections:

PC:

- *Serial A port --- a external modem with 76 cm shielded RS-232 cable
- *Serial B port --- a shielded RS232 cable with 76cm long, no ferrite bead
- *Printer port --- a Printer with 1.2m length data cable
- *Keyboard port --- a Keyboard with 1m length data cable
- *Mouse port --- a Mouse with 0.7m long of data cable
- *Monitor port --- a monitor with 1m length data cable
- *USB ports --- two USB joysticks with 1.5m long, shielded, no ferrite bead data cable

(Each port on PC is connected with suitable device)

EUT:

- * UTP port--- a 20m long, no-shielded, no ferrite bead, RJ-45 cable to the Hub located remotely.

List of support equipment

Conducted (Radiated) test:

PC : HP
Model : VE6/350 SERIES 8
Serial No. : SG91002329
FCC ID : DoC Approval
Power type : AC 100~127 / 200~240 VAC, Switching
Power cord : non-Shielded, 1.7m long, Plastic, no ferrite core

Monitor : HP
Model No. : D2821
Serial No. : TW 73512262 (TW 73147163)
FCC ID : A3KMO64
Power type : AC 110~120 / 220~240 VAC, Switching
Power cord : Non-Shielded, 3m long, no ferrite core
Data cable : Shielded, 1.8m long, with ferrite core

Keyboard : Digital
Model No. : KB-5923
Serial No. : 9S74904837 (9S74904665)
FCC ID : E8HKB-5923
Power type : By PC
Data cable : Shielded, 1.8m long, with ferrite core

Printer : HP
Model No. : C2642A
Serial No. : SG69A196GV
FCC ID : B94C2642X
Power type : 220 VAC, 50Hz
Power cord : Non-shielded, 2m long, no ferrite core
Data cable : Shielded, 1.84m long, no ferrite core (1.7m)

Modem : **ACEEX**
Model No. : XDM-9624
FCC ID : IFAXDM-9624
Power type : 220VAC, 50Hz / 9VAC, 1A
Power cord : Non-shielded, 1.9m long, no ferrite cord
Data cable : RS232, Shielded, 1.2m long, no ferrite core
RJ11C x 2, 7' long non-shielded, no ferrite core

Mouse : **Hewlett Packard Mouse**
Model No. : C3751B
Serial No. : LCA52707170
FCC ID : DZL210582
Power type : Powered by PC
Power Cable : Non – Shielded. 5.5' long, Plastic hoods, No ferrite bead

Joystick : **Padix**
Model : QF-606U, QF-707U (DoC Approval)
Power Type : By PC

Chapter 2 Conducted emission test

Test condition and setup:

All the equipment is placed and setup according to the CISPR 22.

The EUT is assembled on a wooden table that is 80 cm high, is placed 40 cm from the back-wall that is a vertical conducting plane. One LISN is for EUT, the other LISN is for support equipment. They are all placed on the conductive ground. The EUT's LISN connect a line switch box for selecting L1 or L2, then connect to a preamplifier and spectrum.

The spectrum scans from 150KHz to 30MHz. Conducted emission levels are detected at max. peak mode. But if the max. peak mode failed or over average limit, it will be measured by average detection mode.

While testing, there is the worst-emission plot printed at peak detection mode, and there are more than 6 highest emissions relative to limit recorded. The plot is kept as the original data, not included in test report.

List of test Instrument:

<u>Instrument Name</u>	<u>Model No.</u>	<u>Brand</u>	<u>Serial No.</u>	<u>Calibration Date</u>	
				<u>Last time</u>	<u>Next time</u>
Spectrum analyzer	8594EM	H P	3710A00279	01/07/99	01/07/00
LISN (EUT)	3825/2	EMCO	9411-2284	05/20/99	05/20/00
LISN (Support E.)	AC3-001	TRC	-----	05/20/99	05/20/00
Preamplifier	AC3-002	TRC	-----	05/20/99	05/20/00
Line switch box	AC3-003	TRC	-----	05/20/99	05/20/00

The level of confidence of 95%, the uncertainty of measurement of conducted emission is ± 2.4 dB.

Test Result: Pass (Appendix A)

Conducted Test Placement:



Chapter 3 Radiated emission test

Test condition and setup:

Pretest: Prior to the final test (OATS test), the EUT is placed in a anechoic chamber and scan from 30MHz to 1GHz. This is done to ensure the radiation exactly emits form the EUT.

Final test: Final radiation measurement is made on a **10 – meter**, open-field test site. The EUT is placed on a nonconductive table that is 0.8m height, the top surface is 1.0 x 1.5 meter. The placement is according to CISPR 22.

The spectrum is examined from 30 MHz to 1000 MHz measured by HP spectrum.

The EMCO whole range Antenna is used to measure frequency from 30 MHz to 1GHz. The final test is used the spectrum HP 8594EM.

Measure more than six top marked frequencies generated form pretest by computer step by step at each frequency. The EUT is rotated 360 degrees, and antenna is raised and lowered from 1 to 4 meters to find the maximum emission levels. The antenna is used with both horizontal and vertical polarization.

Appropriated preamplifier that is made by TRC is used for improving sensitivity and precautions is taken to avoid overloading. The spectrum analyzer’s 6dB bandwidth is set to 120 KHz, and the EUT is measured at quasi-peak mode.

If the emission is close to the frequency band of ambient, the data will be rechecked by the tester and the corrected data will be written in the test data sheet. If the emission is just within the ambient, the data from anechoic chamber will be taken as the final data.

List of test Instrument:

<u>Instrument Name</u>	<u>Model No.</u>	<u>Brand</u>	<u>Serial No.</u>	<u>Calibration Date</u>	
				<u>Last</u>	<u>Next</u>
Spectrum analyzer	8594EM	H P	3619A00198	11/17/98	11/17/99
RF Pre-selector	AC4-001	TRC	-----	05/20/99	05/20/00
Antenna (30M-2G Hz)	3141	EMCO	9711-1076	12/17/98	12/17/99
Open test side (Antenna, Amplify, cable calibrated together)				05/20/99	05/20/00

The level of confidence of 95%, the uncertainty of measurement of radiated emission is ± 4.96 dB.

Test Result: Pass (Appendix B)

Radiated Test Placement: (Photographs)



Appendix A

Conducted Emission Test Result: (Test Mode: 100X100Mbps)

Testing room: Temperature : 23 ° C Humidity : 64 % RH

Line 1

FREQUENCY (KHz)	READING AMPLITUDE			LIMIT		MARGIN (dB)
	Peak (dBµV/m)	Quasi-peak (dBµV/m)	Average (dBµV/m)	Quasi-Peak (dBµV/m)	Average (dBµV/m)	
198.00	44.04	***.***	***.***	64.63	54.63	-10.59
297.00	34.06	***.***	***.***	61.80	51.80	-17.74
593.00	29.68	***.***	***.***	56.00	46.00	-16.32
692.00	28.67	***.***	***.***	56.00	46.00	-17.33
1478.00	27.42	***.***	***.***	56.00	46.00	-18.58
14210.00	31.47	***.***	***.***	60.00	50.00	-18.53
16260.00	32.14	***.***	***.***	60.00	50.00	-17.86
17700.00	32.08	***.***	***.***	60.00	50.00	-17.92
18210.00	31.62	***.***	***.***	60.00	50.00	-18.38
21560.00	32.91	***.***	***.***	60.00	50.00	-17.09

Line 2

FREQUENCY (KHz)	READING AMPLITUDE			LIMIT		MARGIN (dB)
	Peak (dBµV/m)	Quasi-peak (dBµV/m)	Average (dBµV/m)	Quasi-Peak (dBµV/m)	Average (dBµV/m)	
157.00	37.78	***.***	***.***	65.80	55.80	-18.02
197.00	44.07	***.***	***.***	64.66	54.66	-10.59
297.00	34.79	***.***	***.***	61.80	51.80	-17.01
818.00	29.05	***.***	***.***	56.00	46.00	-16.95
1974.00	28.55	***.***	***.***	56.00	46.00	-17.45
14210.00	31.08	***.***	***.***	60.00	50.00	-18.92
16260.00	32.46	***.***	***.***	60.00	50.00	-17.54
17700.00	31.77	***.***	***.***	60.00	50.00	-18.23
18210.00	33.15	***.***	***.***	60.00	50.00	-16.85
21560.00	32.59	***.***	***.***	60.00	50.00	-17.41

* The reading amplitudes are all under average limit.

Appendix B

Radiated Emission Test Result: (Horizontal)(Test Mode: 100X100Mbps)

Test Conditions:

Testing Room : Temperature : 22.99 ° C Humidity :42 % RH
 Testing Site : Temperature : 30.07 ° C Humidity :48 % RH

Frequency	Reading Amplitude	Ant. Heigh	Table	Correction Factors	Corrected Amplitude	Class B Limit	Margin
MHz	dBµV	m	degree	dB/m	dBµV/m	dBµV/m	dB

38.680	48.40	2.35	295	-22.48	25.92	30.00	-4.08
46.410	36.81	3.93	86	-22.06	14.75	30.00	-15.25
300.480	45.36	3.93	91	-20.85	24.51	37.00	-12.49

Note:

- (1) Margin = Amplitude - limit, if margin is minus means under limit.
 - (2) Corrected Amplitude = Reading Amplitude + Correction Factors
 - (3) Correction factor = Antenna factor + (Cable Loss - Amplitude gain)
- (For example: 30MHz correction factor = 15.5 + (-15.26) = 0.24 dB/m)

Radiated Emission Test Result: (Vertical)(Test Mode: 100X100Mbps)

Frequency	Reading Amplitude	Ant. Heigh	Table	Correction Factors	Corrected Amplitude	Class B Limit	Margin
MHz	dBμV	M	degree	dB/m	dBμV/m	dBμV/m	dB

39.561	45.91	2.41	214	-22.28	23.63	30.00	-6.37
47.041	45.05	0.99	264	-22.01	23.04	30.00	-6.96
69.124	45.14	0.99	193	-24.03	21.11	30.00	-8.89
73.679	44.55	0.99	340	-23.59	20.96	30.00	-9.04
125.031	44.39	0.99	258	-21.88	22.51	30.00	-7.49
149.996	36.42	0.99	166	-20.13	16.29	30.00	-13.71
