



Telocation Systems Ltd.  
18000 E. 1st Ave., Suite 100, Denver, CO 80231  
Tel: 303.440.1111 Fax: 303.440.1111

Customer Support  
CL-01.005

October, 2001

# NXRMU52000-3 ( = “RMU”) INSTALLATION INSTRUCTIONS

## Revision Record:

Date	Description	Written by	Rev.
Oct-01	Initial release	Amit Gelber	-

## The FCC Wants You to Know

This equipment has been tested and found to comply with the limits for a Class B digital device, pursuant to Part 15 of the FCC rules. These limits are designed to provide reasonable protection against harmful interference in a residential installation. This equipment generates, uses and can radiate radio frequency energy and, if not installed and used in accordance with the instructions, may cause harmful interference to radio communications. However, there is no guarantee that interference will not occur in a particular installation. If this equipment does cause harmful interference to radio or television reception, which can be determined by turning the equipment off and on, the user is encouraged to try to correct the interference by one or more of the following measures:

- Reorient or relocate the receiving antenna.
- Increase the separation between the equipment and receiver.
- Connect the equipment to an outlet on a circuit different from that to which the receiver is connected.
- Consult the dealer or an experienced radio/TV technician.

## FCC Warning !

Modifications not expressly approved by the manufacturer  
could void the user authority to operate the equipment under FCC Rules.

This document contains proprietary information that is the sole property of **NEXUS Telocation Systems Ltd.** The document is submitted to the recipient for his use only. By receiving this document; the recipient undertakes not to duplicate or to disclose, in part or the whole, any of the information contained herein; to any third party; without a-priory written permission from **NEXUS Telocation Systems Ltd.**



Telexon Systems Ltd.  
18000 10th St. N. Edmonton, AB T5A 0A8  
Tel: 780.441.1111 Fax: 780.441.1111

Customer Support  
CL-01.005

October, 2001

***Important!***

For proper, reliable functioning of the RMU, read the installation instructions carefully.

Before installing the RMU, pay attention to those basic rules:

- Before installing the RMU in the vehicle, check that the correct voltage is supplied.
- Do not install the RMU close to heat sources (heating system outlets).
- Install the RMU in watertight locations **ONLY**.
- Do not install the RMU in the engine compartment.
- Do not install the RMU behind the fuse box.
- Insulate all loose cables.
- Secure the RMU with screws or strips.
- Install the RMU in the passenger compartment or in the trunk.
- Conceal the RMU, including cables, when installing.



Telelocation Systems Ltd.  
1 Riverside Dr., 4th Fl., Glenview, IL 60045, USA  
Tel: +1(847)411-1100 Fax: +1(847)411-1101

## Wiring Connections:

The RMU (Ver. 1.7), uses “Molex” type connector (Serial number 70553-0014), as following:

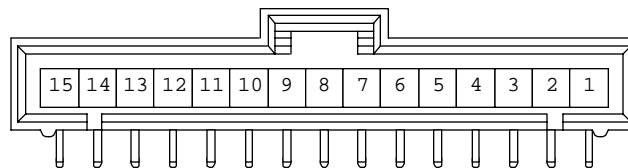

<u>Pin 1</u>	:	Ground
<u>Pin 2</u>	:	+12v
<u>Pin 3</u>	:	+Rx Data
<u>Pin 4</u>	:	- Rx Data
<u>Pin 5</u>	:	+Tx Data
<u>Pin 6</u>	:	- Tx Data
<u>Pin 7</u>	:	Output “B”
<u>Pin 8</u>	:	LED
<u>Pin 9</u>	:	Output “A”
<u>Pin 10</u>	:	Output “C”
<u>Pin 11</u>	:	Input “A”
<u>Pin 12</u>	:	Input “B”
<u>Pin 13</u>	:	Input “C”
<u>Pin 14</u>	:	Input “D”
<u>Pin 15</u>	:	Output “Gnd.”



Telecom Systems Ltd.  
1 Riverside Dr., 4th Fl., Gwynedd, 22863, Inverness  
Tel: 402.443.1141 Fax: 402.443.1888

Customer Support  
CL-01.005

October, 2001

## Wiring Diagram:

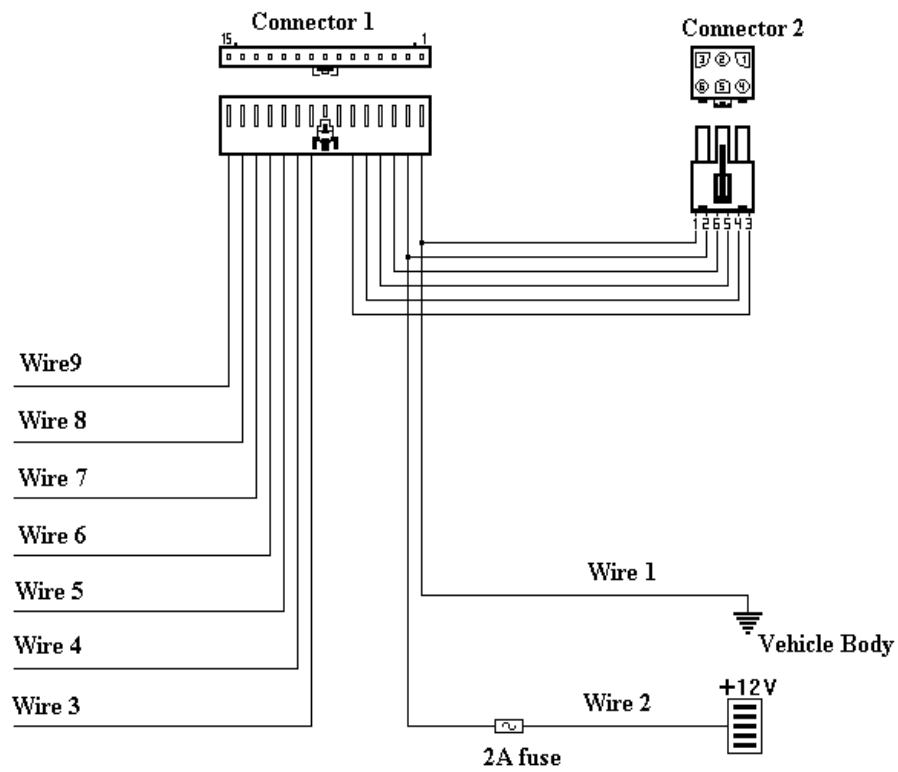



Telexon Systems Ltd.  
1 Riverside Dr., 4th Fl., Greenway, 6883, Jersey  
Tel: +352 4733333 Fax: +352 4733333

## Connecting the Wires - Connector 1

### ELECTRICAL INTERFACE

Pin	Name	Description
1	Ground.	Power Supply.
2	Vcc (+ 12V).	Vcc Range (8-17 Volt)
3	RS 422 (Rx+)	Serial Port.
4	RS 422 (Rx-)	
5	RS 422 (Tx+)	
6	RS 422 (Tx-)	
7	OUTPUT <b>B</b>	OFF = 0 Volt. ON = 12 Volt / 130 mAmp
8	OUTPUT <b>LED</b>	12 mAmp max
9	OUTPUT <b>A</b>	OFF = 0 Volt. ON = 12 Volt / 130 mAmp
10	OUTPUT <b>C</b>	OFF = 0 Volt. ON = 12 Volt / 130 mAmp.
11	INPUT <b>A</b>	Default: Active High. (>3.0 Volt)
12	INPUT <b>B</b>	Default: Active Low. (< 0.6 Volt)
13	INPUT <b>C</b>	Default: Active Low. (< 0.6 Volt)
14	INPUT <b>D</b>	Default: Active Low. (< 0.6 Volt)
15	OUTPUT GND.	Internal Loop.

Wire 1: Connect Wire 1 permanently to the vehicle body. The connection site must be protected against corrosion.

Wire 2: Connect Wire 2 to a permanent positive connection (+) in the fuse box.

Wire 3: See Option 2.

Wire 4: See Option 1.

Wire 5: See Option 1.

Wire 6: Optional connection to alarm system.

Outlet A. Connect through relay to the output of an additional alarm system siren.

**Connect according to the diagram:**

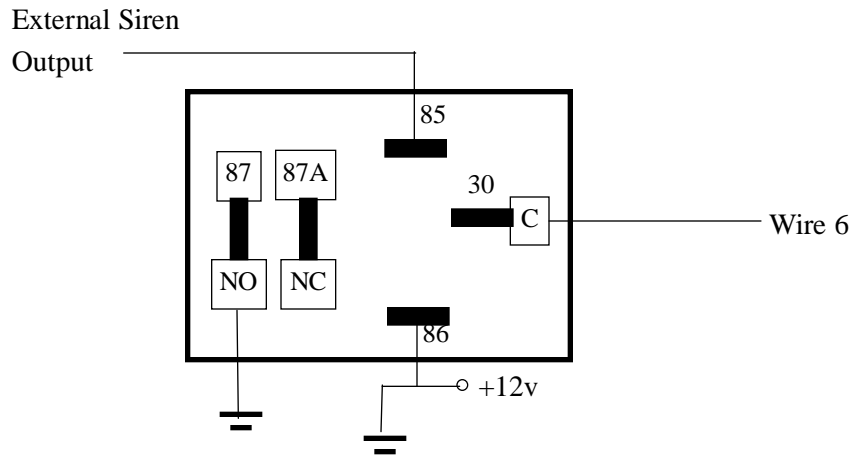

**Note:** The connection numbers correspond to the BOSCH 12V 40A relay.

Wire 7: Outlet B. Do not connect. Insulate outlet B.

Wire 8: Optional connection for distress button.

Outlet C. Can be use as an distress button outlet.

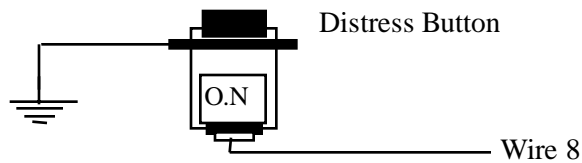

Wire 9: Do not connect. Insulate Wire 9.



Telelocation Systems Ltd.  
1 Riverside Dr., 4th Fl., Gwynedd, 22865, Jersey  
Tel: +354 441111 Fax: +354 441111

## Installing Antennas

### ***Important!***

Proper installation of the antennas is vital for the reliable functioning of the RMU.

### ***Very important:***

- Do not shorten or lengthen the antenna cables.
- Do not position the antennas near the vehicle computer or any other transmitter.
- Do not combine antennas.
- Position antennas at least 10 cm away from metal.
- Antennas can be installed horizontally or vertically. The cable can be rolled up.
- Antennas can be fixed or held in position using adhesive tape or strips.

### ***Optional Antenna Sites :***

Front dash board:	Inside the upper section of the dash board. The antennas are positioned above the window line.
Rear dash board:	Between the shelf and the metal surface. Position as far away as possible from the metal. Mount above the window line.
On the vehicle ceiling:	The RMU can be installed in trucks or cars that have a space (at least 10 cm) between the ceiling covering and the ceiling. Antennas can be distributed.

## Options

### Option 1:

Wires 4 and 5: Split alarms. No connection to an additional siren. Wires 4 can serve and 5 as current detector (up to maximum 1.5 Amp.).

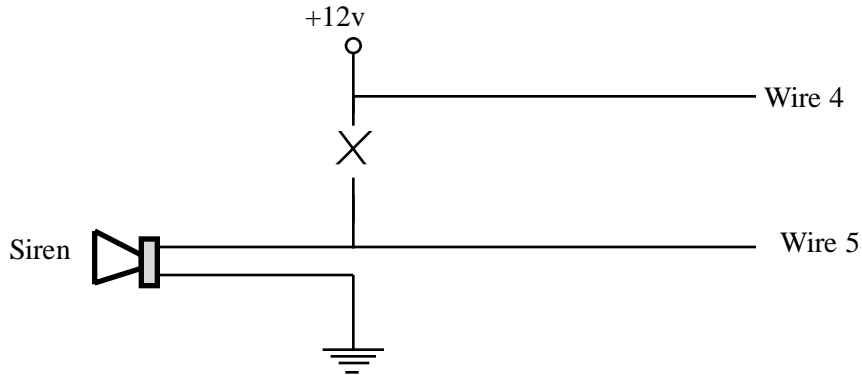

### Option 2:

Wire 3: Positive (+) output (up to 130mA) to an external relay.

The output (Wire 3) can be used to operate an external relay. The relay serves to connect/disconnect an accessory in the vehicle, e.g. indicators, additional siren, etc.

The relay is controlled by the control center.

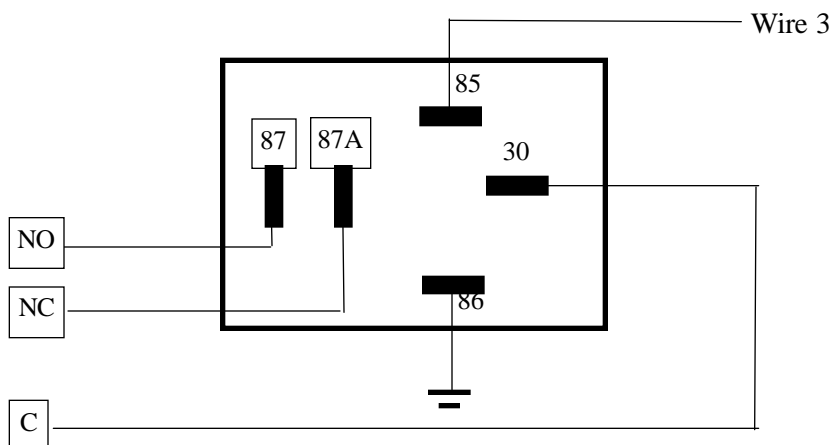





Telocation Systems Ltd.  
1 Riverside Dr., 4th FL, Greenway, 32801, Jacksonville, FL 32202  
Tel: 904.433.1100 Fax: 904.433.1988

**The RMU kit includes:**

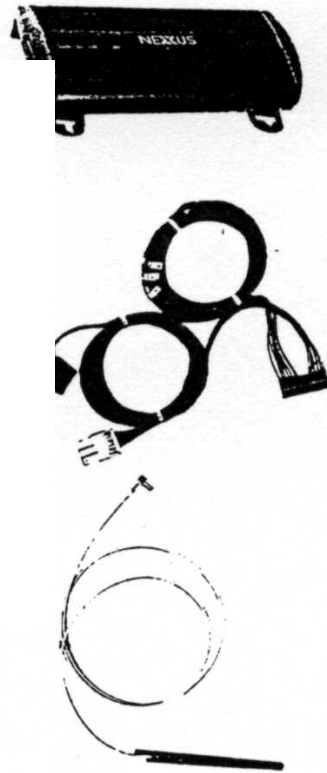

**Electrical diagram - BOSCH 12V 40A relay**

